

**Common Core Math 2**  
**Final Exam Review Packet**

Name: \_\_\_\_\_

Use this packet for questions from every unit that will help you prepare for the NC Final Exam for Common Core Math 2.

<b>Unit</b>	<b>Packet Pages</b>
<b>Unit 1 A and B:</b> Transformations of shapes and tools of geometry	1-15
<b>Unit 2 A and B:</b> Quadratic functions, quadratic graphs, and applications of quadratics	16-20
<b>Unit 3:</b> Exponents, radicals, exponential functions and logarithmic functions	21-24
<b>Unit 4:</b> Advanced functions and transformations	25-32
<b>Unit 5:</b> Trigonometry	33-36
<b>Unit 6:</b> Probability	37-39

Final Exam Review, Unit 1

Name: \_\_\_\_\_

Date: \_\_\_\_\_

1. The measures of two angles of a triangle are 70 and 55. This triangle is

- A. a right triangle
- B. a scalene triangle
- C. an obtuse triangle
- D. an isosceles triangle

2. In  $\triangle QRS$ ,  $m\angle Q = x$ ,  $m\angle R = 8x - 40$ , and  $m\angle S = 2x$ . Which type of triangle is  $\triangle QRS$ ?

- A. isosceles
- B. right
- C. acute
- D. obtuse

3. A right triangle contains a  $38^\circ$  angle whose adjacent side measures 10 centimeters. What is the length of the hypotenuse, to the *nearest hundredth of a centimeter*?

- A. 7.88
- B. 12.69
- C. 12.80
- D. 16.24

4. In the diagram below,  $\triangle LMO$  is isosceles with  $LO = MO$ .

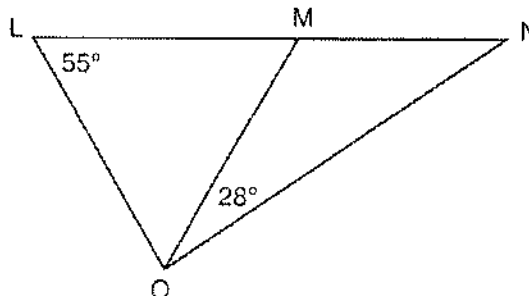

If  $m\angle L = 55$  and  $m\angle NOM = 28$ , what is  $m\angle N$ ?

- A. 27
- B. 28
- C. 42
- D. 70

5. The two acute angles in an isosceles right triangle must measure

- A.  $30^\circ$  and  $60^\circ$
- B.  $35^\circ$  and  $55^\circ$
- C.  $40^\circ$  and  $50^\circ$
- D.  $45^\circ$  and  $45^\circ$

6. Tina wants to sew a piece of fabric into a scarf in the shape of an isosceles triangle, as shown in the accompanying diagram. What are the values of  $x$  and  $y$ ?

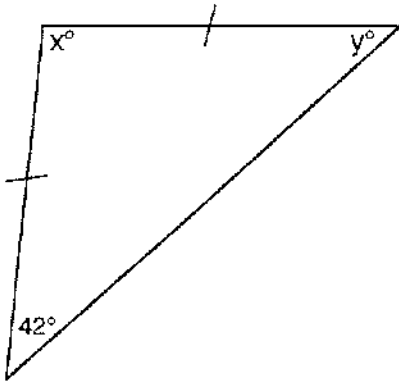

- A.  $x = 42$  and  $y = 96$     B.  $x = 69$  and  $y = 69$   
 C.  $x = 90$  and  $y = 48$     D.  $x = 96$  and  $y = 42$

7. In the diagram below,  $\triangle ABC \cong \triangle XYZ$ .

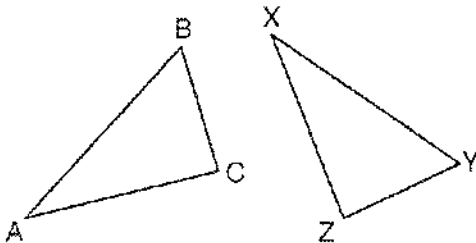

Which two statements identify corresponding congruent parts for these triangles?

- A.  $\overline{AB} \cong \overline{XY}$  and  $\angle C \cong \angle Y$   
 B.  $\overline{AB} \cong \overline{YZ}$  and  $\angle C \cong \angle X$   
 C.  $\overline{BC} \cong \overline{XY}$  and  $\angle A \cong \angle Y$   
 D.  $\overline{BC} \cong \overline{YZ}$  and  $\angle A \cong \angle X$

8. In the accompanying diagram of  $\triangle ABC$ ,  $\overline{BC}$  is extended to  $D$ ,  $m\angle A = 20$ ,  $m\angle ACD = 70$ , and  $m\angle B = x$ .

What is the value of  $x$ ?

- A. 110    B. 90  
 C. 70    D. 50

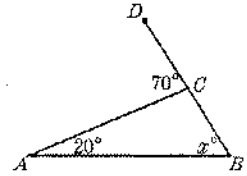

9. In the accompanying diagram of  $\triangle ABC$ , side  $\overline{AB}$  is extended to  $D$ . If  $m\angle ACB = x + 30$ ,  $m\angle CAB = 2x + 10$ , and  $m\angle CBD = 4x + 30$ , what is the value of  $x$ ?

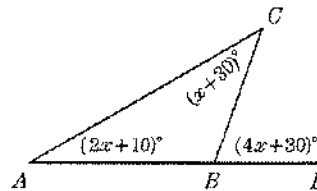

10. Two angles of a triangle measure  $65^\circ$  and  $75^\circ$ . Which is *not* the measure of an exterior angle of the triangle?

- A.  $105^\circ$     B.  $115^\circ$     C.  $130^\circ$     D.  $140^\circ$

11. The lengths of the sides of a triangle are 8, 15, and 17. If the longest side of a similar triangle is 51, what is the length of the *shortest* side?

- A. 32    B. 24    C. 16    D. 4

12. In the accompanying diagram,  $\overline{BAE}$ ,  $\overline{CAD}$ ,  $\angle B$  and  $\angle E$  are right angles,  $AB = 3$ ,  $BC = 4$ , and  $AD = 15$ .

What is the length of  $DE$ ?

- A. 5      B. 8  
C. 9      D. 12

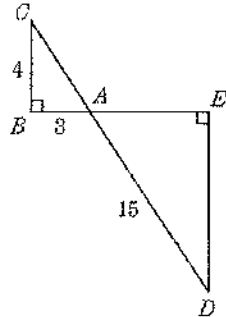

13. The sides of  $\triangle ABC$  are 2, 3, and 4. Which set of numbers could represent the sides of a triangle similar to  $\triangle ABC$ ?

- A. {5, 6, 7}      B. {6, 9, 16}  
C. {12, 13, 14}      D. {20, 30, 40}

14. If a tree cast a 90-foot shadow at the same time a 3-foot pole held perpendicular to the ground casts a 5-foot shadow, what is the height of the tree, expressed in feet?

- A. 18      B. 54      C. 72      D. 150

15. Jordan and Missy are standing together in the schoolyard. Jordan, who is 6 feet tall, casts a shadow that is 54 inches long. At the same time, Missy casts a shadow that is 45 inches long. How tall is Missy?

- A. 38 in      B. 86.4 in  
C. 5 ft      D. 5 ft 6 in

16. Parallelogram  $ABCD$  was translated to parallelogram  $A'B'C'D'$ .

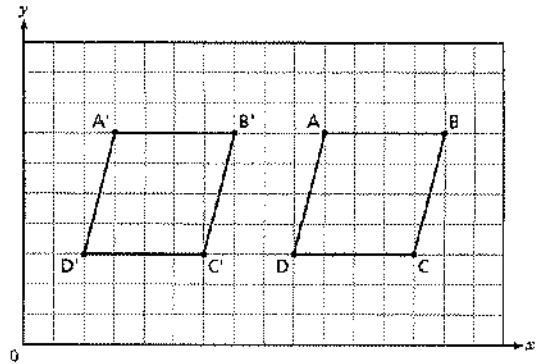





How many units and in which direction were the  $x$ -coordinates of parallelogram  $ABCD$  moved?

- A. 3 units to the right      B. 3 units to the left  
C. 7 units to the right      D. 7 units to the left

17. Ruby is making a calendar.

**March** 

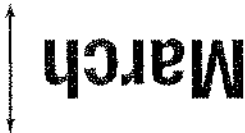
Which shows a slide of the word "March" over the line?

- A. 
- B. 
- C. 
- D. 

18. A shape is shown below.

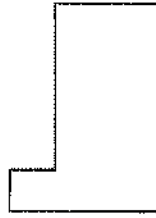

Which shows this shape transformed by a flip?

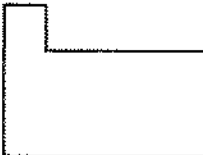
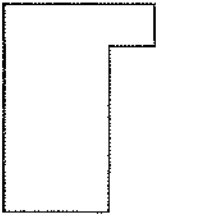
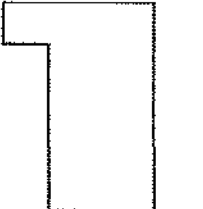
- A. 
- B. 
- C. 
- D. 

19. Joanne and Christopher are designing a quilt. They start by creating a triangle shape in the lower left quadrant as shown below.

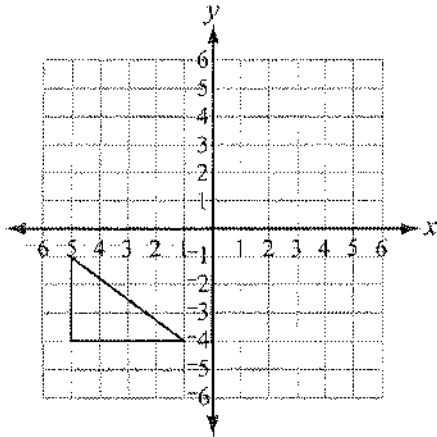

They transform it by rotating the triangle shown above  $90^\circ$  clockwise about the origin. What does the new design look like?

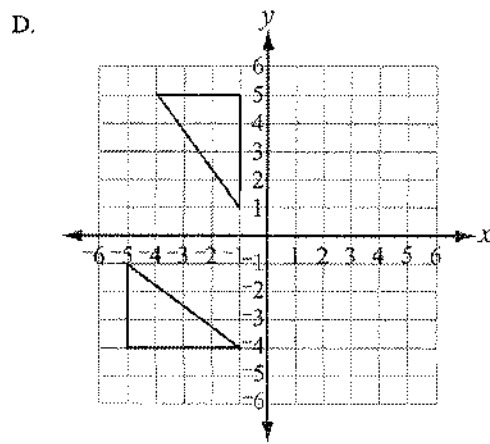
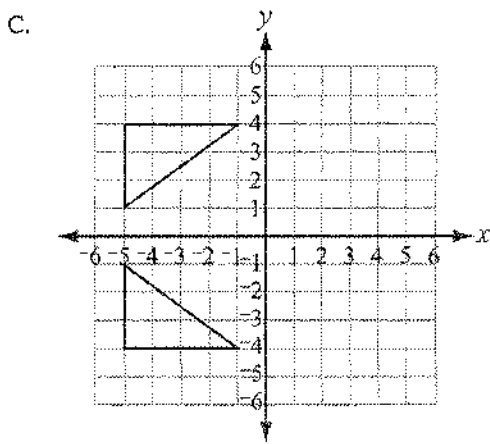
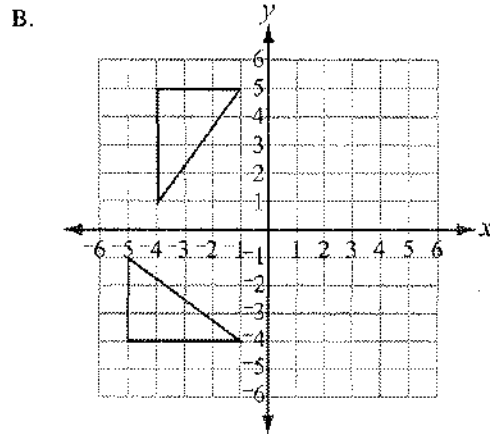
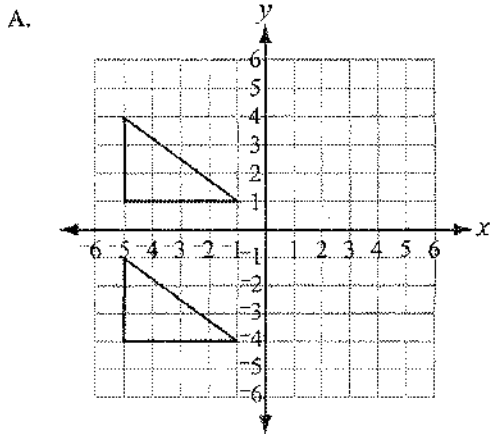

20. Alyssa made the design shown below.

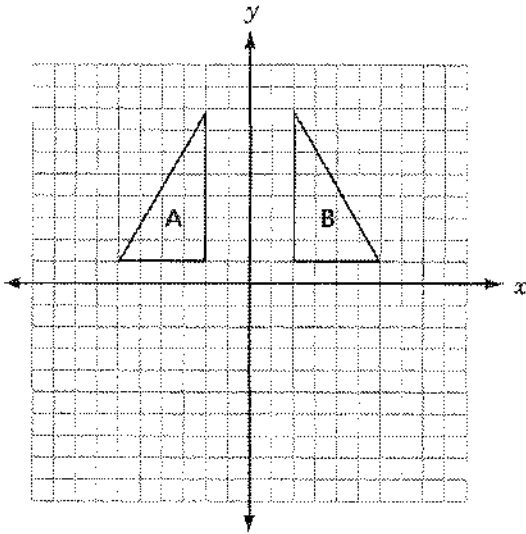

Which transformation could be used to show that figure A is congruent to figure B?

- A. add 5 to each  $x$ -coordinate
- B. multiply each  $y$ -coordinate by  $-1$
- C. multiply each  $x$ -coordinate by  $-1$
- D. rotate the figure 90 degrees about the origin

21. Which graph shows a reflection of the rectangle across the horizontal dotted line?

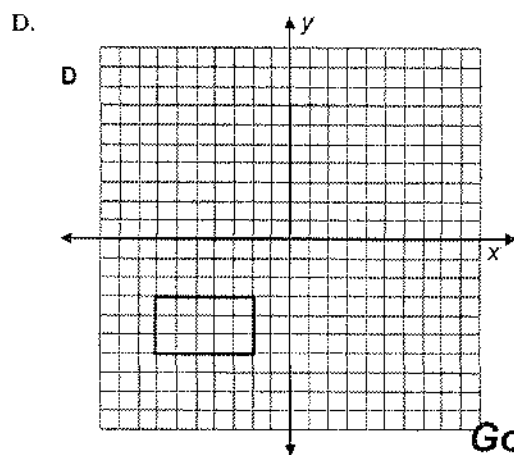
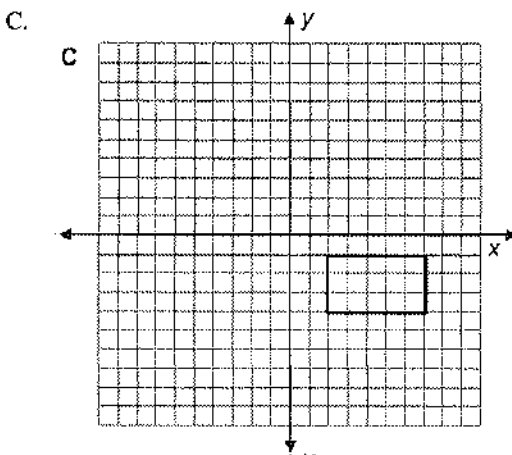
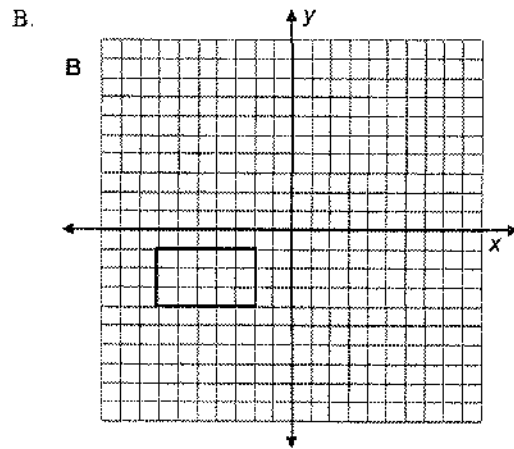
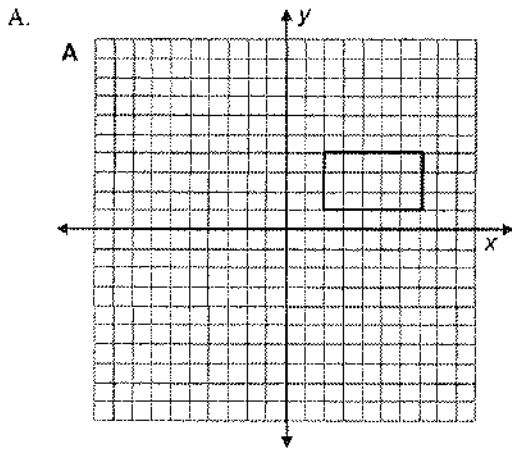
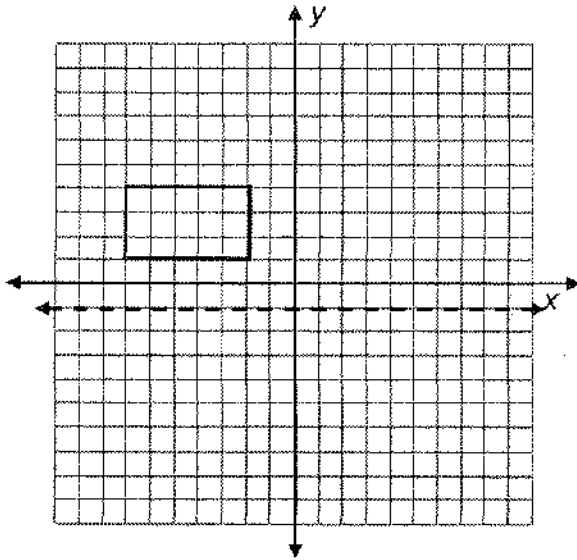

Go



22. Polygon  $A$  will be rotated counter-clockwise  $90^\circ$  about point  $P$  to form polygon  $A'$ .

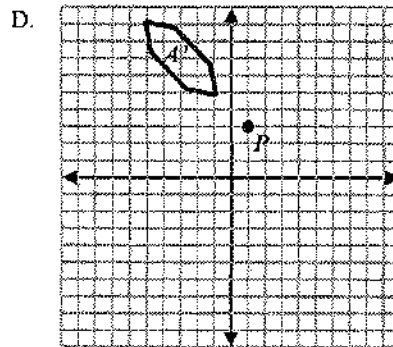
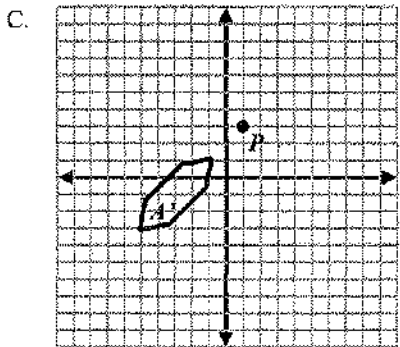
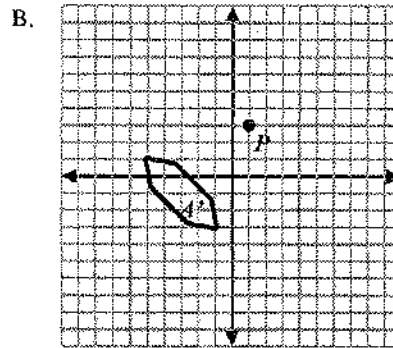
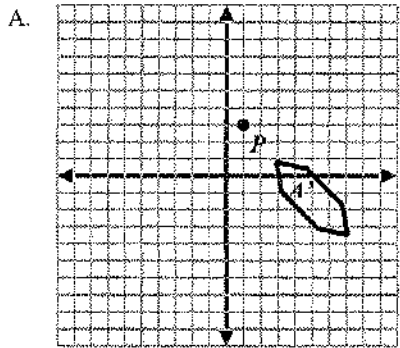
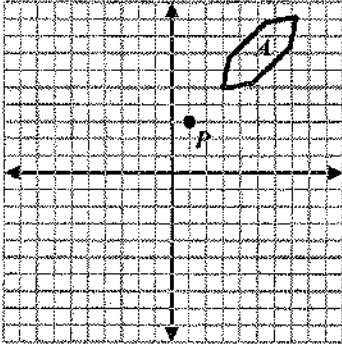

23. Which of the following is a single reflection of figure  $N$  over the  $y$ -axis to form  $N'$ ?

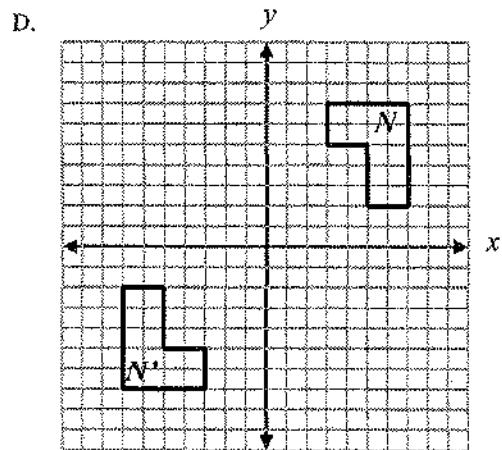
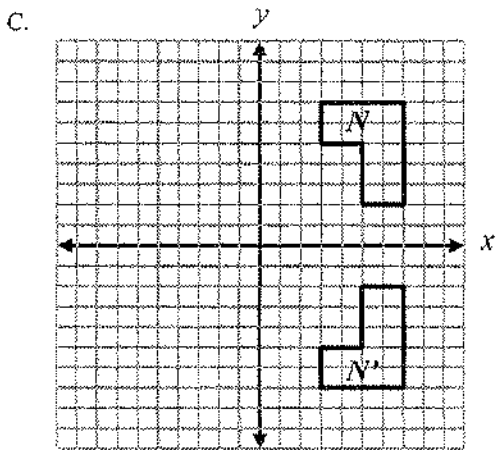
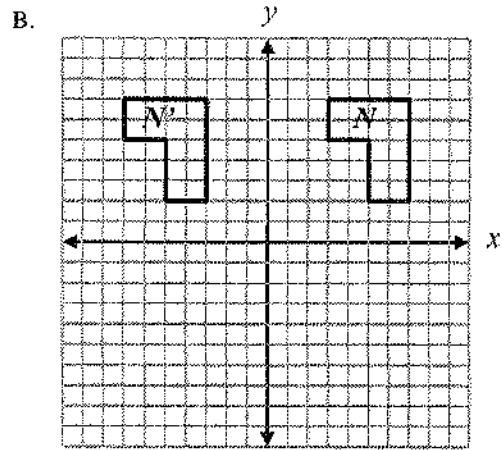
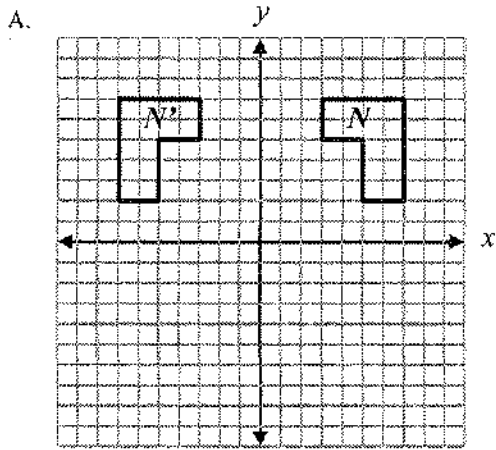

9

24. Which figure shows the triangle below reflected over the  $x$ -axis, then reflected over the  $y$ -axis?

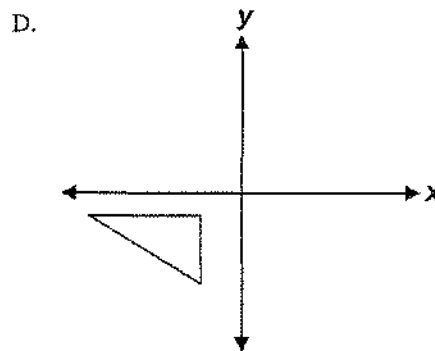
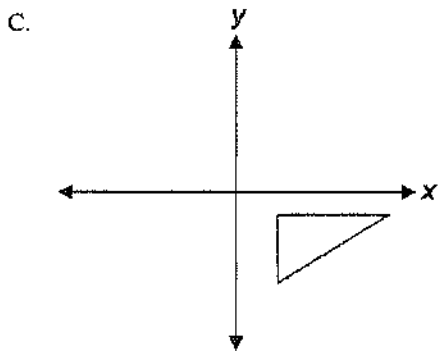
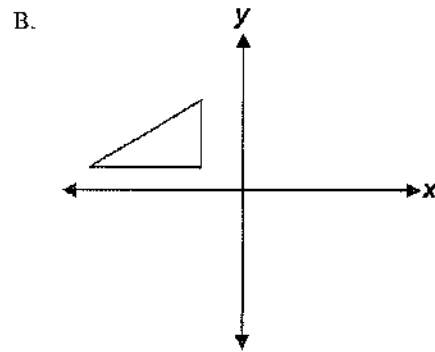
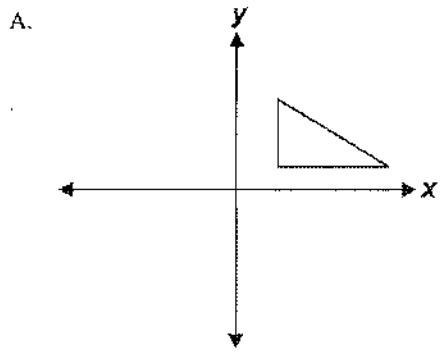
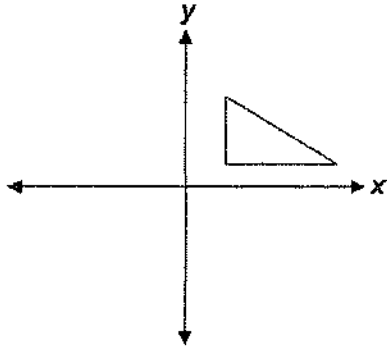

25. Figure  $EFGH$  in the coordinate plane has vertices at  $(-5, 2)$ ,  $(-5, -2)$ ,  $(-1, -2)$ , and  $(-1, 2)$ .

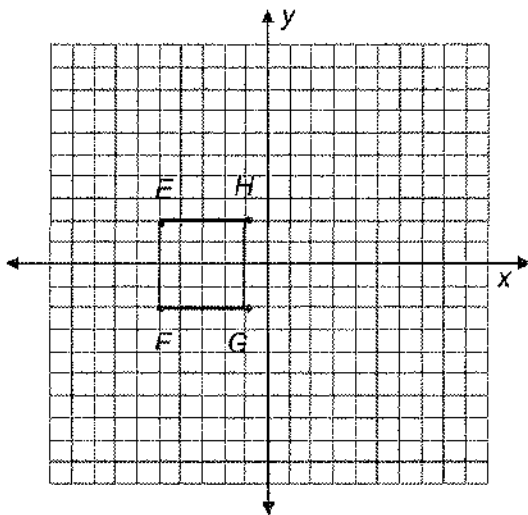

If the figure is translated 5 units to the right and 2 units up, what are the coordinates of the  $E'F'G'H'$ ?

- A.  $(0, 4)$ ,  $(0, 0)$ ,  $(4, 0)$ ,  $(4, 4)$   
 B.  $(-3, 7)$ ,  $(-3, 3)$ ,  $(1, 3)$ ,  $(1, 7)$   
 C.  $(-10, 0)$ ,  $(-10, 4)$ ,  $(-6, -4)$ ,  $(-6, 0)$   
 D.  $(-7, -3)$ ,  $(-7, -7)$ ,  $(-3, -7)$ ,  $(-3, -3)$
26. A polygon has been rotated about the origin. Which statement must be true?
- A. The lengths of the sides are doubled.  
 B. The area of the polygon did not change.  
 C. The coordinates of the vertices did not change.  
 D. The area of the polygon is 4 Times its original area.

27. Three transformations will be performed on triangle  $ABC$ . Which set of transformations will always produce a congruent triangle?

- A. dilation, rotation, translation  
 B. reflection, dilation, translation  
 C. rotation, reflection, dilation  
 D. rotation, translation, reflection

28. If triangle  $ABC$  is rotated 180 degrees about the origin, what are the coordinates of  $A'$ ?

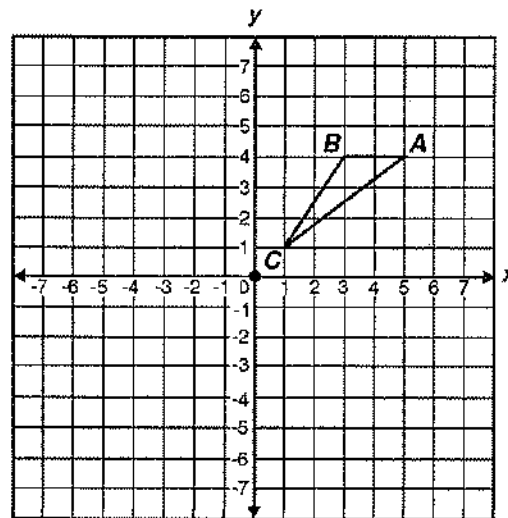

- A.  $(-5, -4)$       B.  $(-5, 4)$   
 C.  $(-4, 5)$       D.  $(-4, -5)$

29. The diagram below shows  $\triangle HIJ$  and its image  $\triangle H'I'J'$  after a single transformation.

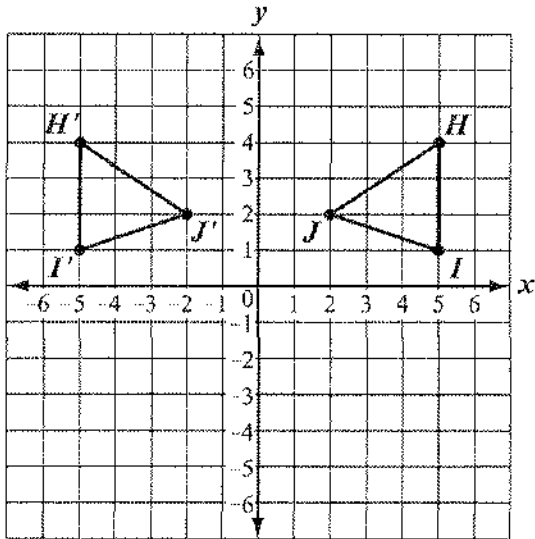

Which of the following describes the transformation?

- A. reflection over the x-axis
- B. reflection over the y-axis
- C. rotation  $90^\circ$  clockwise about the origin
- D. rotation  $180^\circ$  clockwise about the origin

30. Look at  $\triangle LMN$  on the coordinate plane.

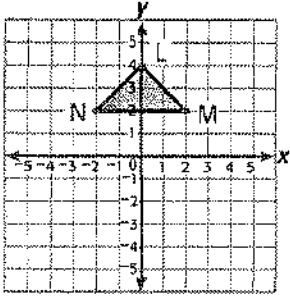

Which coordinate plane shows  $\triangle LMN$  after a  $90^\circ$  counterclockwise rotation about the origin?

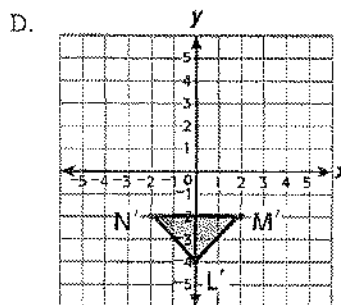
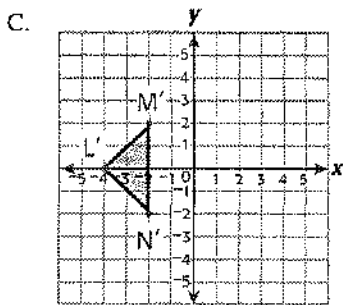
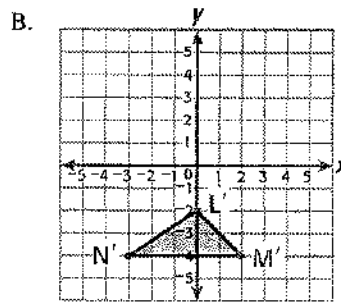
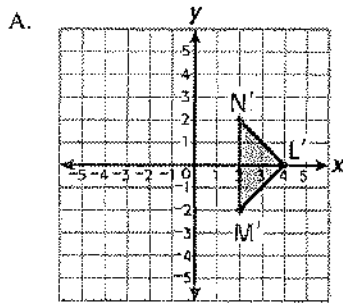

31. A triangle is shown.

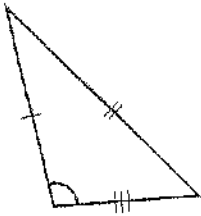

Which triangle is congruent to this triangle?

A.

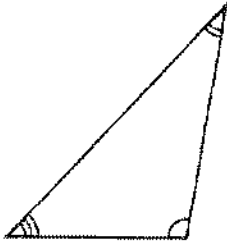

B.

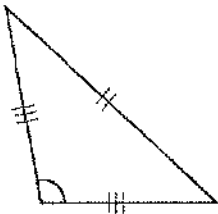

C.



D.

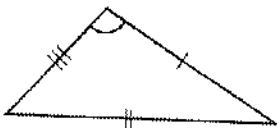

32. A triangular tile is shown.

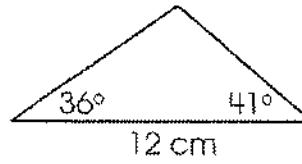

Patrick needs another tile that is congruent to this tile for the design on his kitchen wall.

Which tile is congruent to the original tile?

A.

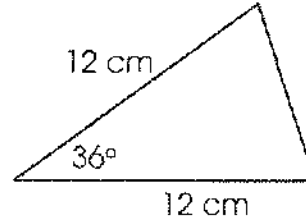

B.

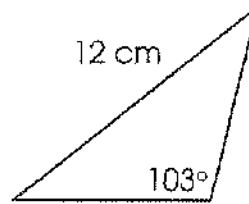

C.

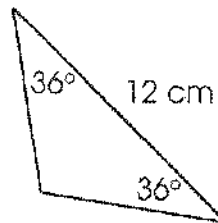

D.

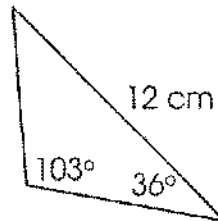

33. Use the figure below to answer the following question.

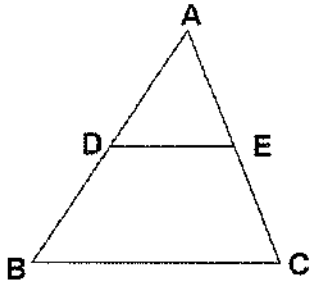

In this figure, D and E are midpoints of the sides of triangle ABC. The perimeter of triangle ADE is 18 centimeters. What is the perimeter of triangle ABC?

- A. 27 centimeters      B. 36 centimeters  
C. 54 centimeters      D. 72 centimeters

34. A flagpole casts a shadow 27 feet long. Larry is 6 feet tall and casts a 5-foot shadow.

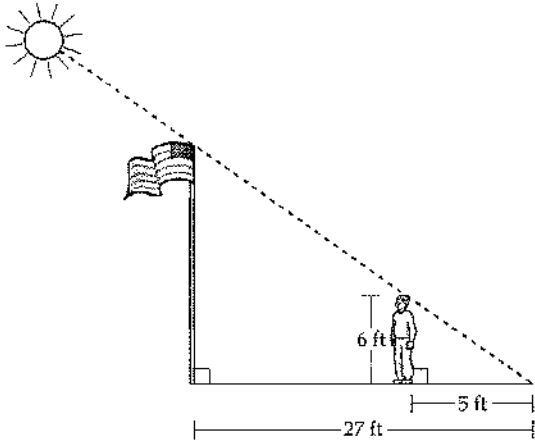

Note: The figure is not drawn to scale.

How tall is the flagpole? Round the answer to the nearest foot.

- A. 18 feet      B. 25 feet  
C. 28 feet      D. 32 feet

35. In  $\triangle ABC$ , Z is the midpoint of  $\overline{AC}$  and Y is the midpoint of  $\overline{BC}$ .

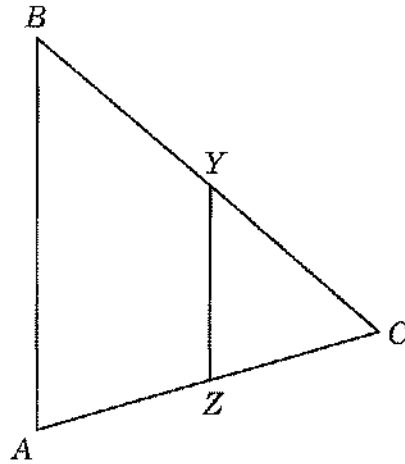

If  $YZ = 21$  and  $AB = (2x - 4)$ , what is  $x$ ?

- A. 7.25      B. 12.5      C. 23      D. 46

36. Triangle ABC and triangle CED are similar. Find the measure of  $\angle A$ .

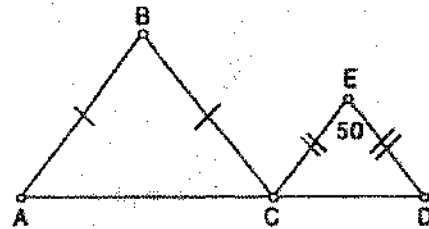

- A.  $65^\circ$       B.  $80^\circ$       C.  $90^\circ$       D.  $130^\circ$



Final Exam Review, Unit 2

Name: \_\_\_\_\_

Date: \_\_\_\_\_

- A ball is thrown straight up at an initial velocity of 54 feet per second. The height of the ball  $t$  seconds after it is thrown is given by the formula  $h(t) = 54t - 12t^2$ . How many seconds after the ball is thrown will it return to the ground?

A. 9.2    B. 6    C. 4.5    D. 4
- The height of a swimmer's dive off a 10-foot platform into a diving pool is modeled by the equation  $y = 2x^2 - 12x + 10$ , where  $x$  represents the number of seconds since the swimmer left the diving board and  $y$  represents the number of feet above or below the water's surface. What is the farthest depth below the water's surface that the swimmer will reach?

A. 6 feet    B. 8 feet  
C. 10 feet    D. 12 feet
- What is the solution set of the equation  $x^2 - 3x - 10 = 0$ ?

A. (5, -2)    B. (-5, -2)  
C. (5, 2)    D. (-5, 2)
- What is the solution set of  $x^2 - x - 20 = 0$ ?

A. (5, -4)    B. (-5, 4)  
C. (-10, 2)    D. (10, -2)
- What is the solutions set of the equation  $2x^2 + x - 3 = 0$ ?

A.  $\{\frac{1}{2}, -3\}$     B.  $\{-\frac{3}{2}, 1\}$   
C.  $\{-\frac{1}{2}, -3\}$     D.  $\{\frac{3}{2}, 1\}$
- Solve for the positive value of  $x$ :  $\frac{4}{x+3} = \frac{x-5}{5}$
- For which equation is the solution set  $\{-5, 2\}$ ?

A.  $x^2 + 3x - 10 = 0$     B.  $x^2 - 3x = 10$   
C.  $x^2 + 3x = -10$     D.  $x^2 - 3x + 10 = 0$
- Which must be true for  $x$  in the equation  $\frac{1}{x} + \frac{1}{x+3} = 2$ ?

A.  $x = 0, x = -3$     B.  $x \neq 0, x = -3$   
C.  $x = 0, x \neq -3$     D.  $x \neq 0, x \neq -3$
- What is the solution set of the equation  $\frac{x}{5} + \frac{x}{2} = 14$ ?

A. {4}    B. {10}    C. {20}    D. {49}
- What is the value of  $x$  in the equation  $\frac{x}{2} + \frac{x}{6} = 2$ ?

A. 12    B. 8    C. 3    D.  $\frac{1}{4}$

11. What is the solution set of the equation

$$\frac{x}{x-4} - \frac{1}{x+3} = \frac{28}{x^2 - x - 12}?$$

- A. { }                      B. {4, -6}  
 C. {-6}                    D. {4}

12. Which value of  $x$  is the solution of

$$\frac{2x}{5} + \frac{1}{3} = \frac{7x-2}{15}?$$

- A.  $\frac{3}{5}$                       B.  $\frac{31}{26}$                       C. 3                      D. 7

13. Which value of  $x$  is the solution of  $\frac{2x-3}{x-4} = \frac{2}{3}$ ?

- A.  $-\frac{1}{4}$                       B.  $\frac{1}{4}$                       C. -4                      D. 4

14. Which of the following represents the graph of the equation below?

$$y = x^2 - 4$$

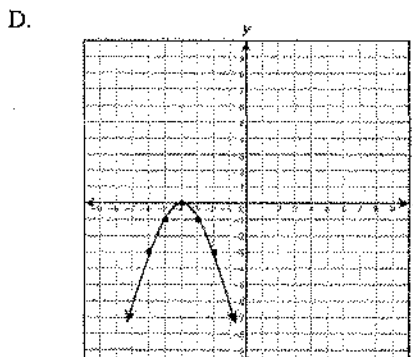
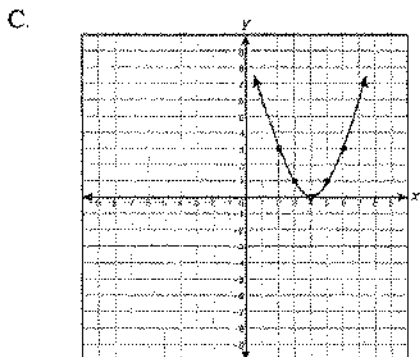
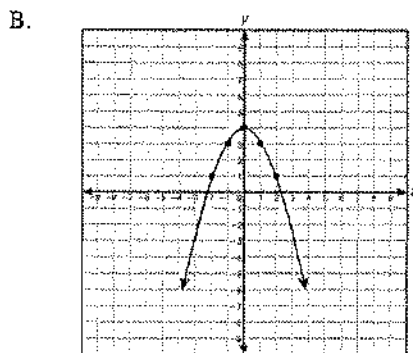
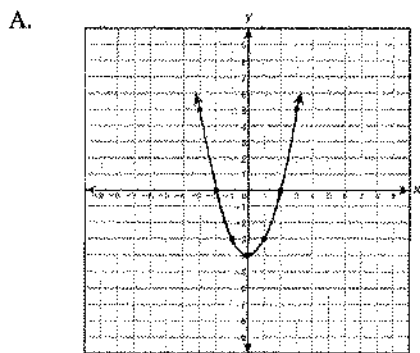

15. Which of the following represents the graph of the equation below?

$$y = -x^2 + 2$$

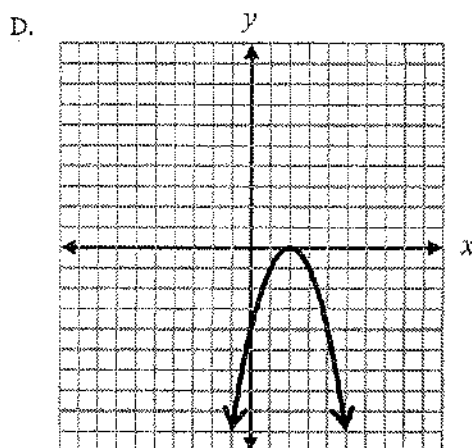
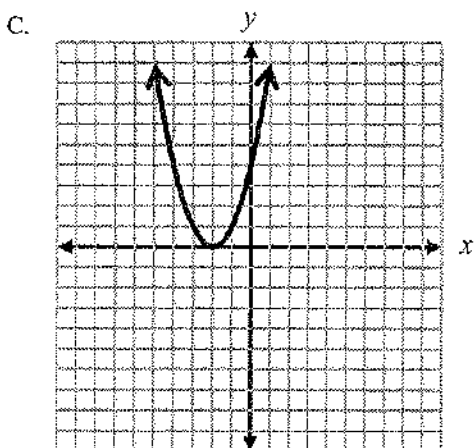
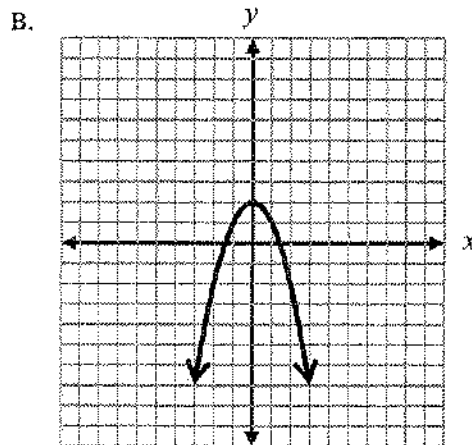
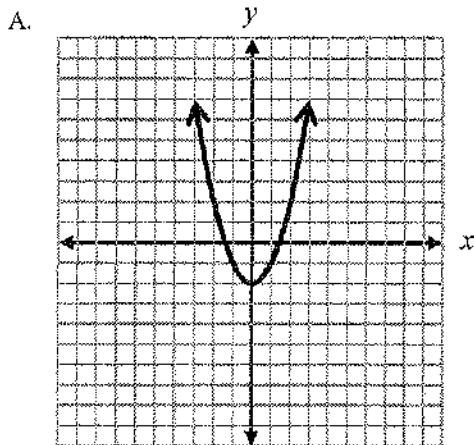

16. An object that is projected straight downward with initial velocity  $v$  feet per second travels a distance  $s = vt + 16t^2$ , where  $t$  = time in seconds. If Ramón is standing on a balcony 84 feet above the ground and throws a penny straight down with an initial velocity of 10 feet per second, in how many seconds will it reach the ground?

- A. 2 seconds                      B. 3 seconds  
 C. 6 seconds                      D. 8 seconds

17. How many times does the graph of  $y = 2x^2 - 2x + 3$  intersect the  $x$ -axis?

- A. none    B. one    C. two    D. three

18. For her research project, Sherry asked some high school and college students their age,  $x$ , and the average number of hours they worked per week,  $y$ . Her data are shown.

Student	Age (years)	Hours Per Week (average)
Alan	10	10
Jose	18	15
Erica	16	8
Tina	17	8
Pamela	17	12
Jin	20	14
Danitza	18	14
Hugo	19	16
Tionna	22	9
Myron	22	8

Sherry used a calculator to find a quadratic regression equation to model the data, rounding the coefficients to the nearest thousandth.

What is the average number of hours per week a 23-year-old would work (rounded to nearest whole number)?

- A. 4 hours                      B. 5 hours  
C. 7 hours                      D. 8 hours
19. What are the solutions of the equation below?

$$5x(x + 8) = 0$$

- A.  $x = -5$ ;  $x = -8$       B.  $x = 0$ ;  $x = -8$   
C.  $x = 0$ ;  $x = 8$          D.  $x = 5$ ;  $x = 8$

20. Pedro throws a ball upward at a rate of 20 meters per second from an initial height of 2 meters. The height of the ball above the ground can be approximated by  $h = -5t^2 + 20t + 2$ , where  $t$  represents the amount of time, in seconds, since the ball has been released.

What is the maximum height that the ball reaches?

- A. 5 meters                      B. 6 meters  
C. 20 meters                    D. 22 meters

21. What is the *sum* of the solutions to the equation shown below?

$$x^2 - 12 = 4$$

- A. -4      B. 0      C. 4      D. 12

22. The graph of a quadratic function is shown below.

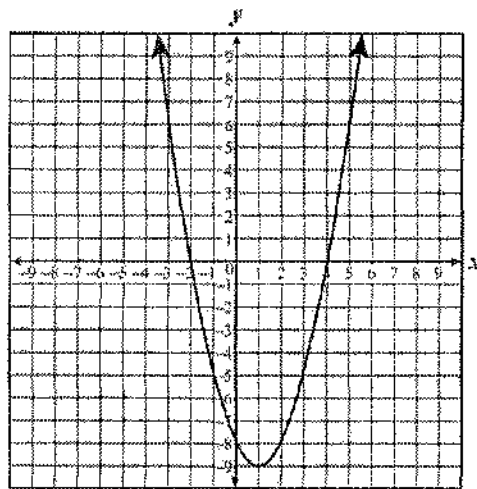

Which set includes the zeros of this function?

- A.  $\{2, 4\}$                       B.  $\{-2, 4\}$   
C.  $\{-4, 2\}$                     D.  $\{-4, -2\}$

23. If  $x^2 - 6x - 16$  is written in the form  $a(x - h)^2 + k$ , what is the value of  $a + h + k$ ?
- A. -27    B. -21    C. 12    D. 29

24. A ball is tossed into the air. The height of the ball as a function of time can be described by the equation  $h = -16t^2 + 72t$ . In this equation  $h$  is the height of the ball in feet and  $t$  is time in seconds.
- After how many seconds will the ball hit the ground?
- A. 4 seconds                      B. 4.5 seconds  
C. 9 seconds                        D. 56 seconds

25. Which of the following statements *best* describes the solution(s) of  $\frac{1}{3}x^2 + \frac{1}{6}x = 3$ ?
- A. no solution  
B. 1 negative solution  
C. 1 positive solution and 1 negative solution  
D. 2 positive solutions

26. A company found that its monthly profit,  $P$ , is given by  $P = -10x^2 + 120x - 150$  where  $x$  is the selling price for each unit of product. Which of the following is the *best* estimate of the maximum price that the company can charge without losing money?
- A. \$300.24                      B. \$210.00  
C. \$10.58                        D. \$6.00

27. Suppose that the equation  $V = 20.8x^2 - 458.3x + 3,500$  represents the value of a car from 1964 to 2002.
- What year did the car have the least value? ( $x = 0$  in 1964)
- A. 1965    B. 1970    C. 1975    D. 1980

Final Exam Review, Unit 3

Name: \_\_\_\_\_

Date: \_\_\_\_\_

- The value of  $(\frac{8}{27})^{-\frac{2}{3}}$  is  
 A.  $\frac{4}{9}$     B.  $-\frac{4}{9}$     C.  $-\frac{2}{3}$     D.  $\frac{9}{4}$
- The expression  $8^{-\frac{2}{3}}$  is equivalent to  
 A.  $\frac{1}{4}$     B.  $-\frac{1}{4}$     C.  $-4$     D.  $4$
- The value of  $(\frac{3^0}{27^{\frac{2}{3}}})^{-1}$  is  
 A.  $-9$     B.  $9$     C.  $-\frac{1}{9}$     D.  $\frac{1}{9}$
- If  $x$  is a positive integer,  $4x^{\frac{1}{2}}$  is equivalent to  
 A.  $\frac{2}{x}$     B.  $2x$     C.  $4\sqrt{x}$     D.  $4\frac{1}{x}$
- The expression  $\sqrt[4]{16a^6b^4}$  is equivalent to  
 A.  $2a^2b$     B.  $2a^{\frac{3}{2}}b$     C.  $4a^2b$     D.  $4a^{\frac{3}{2}}b$
- When simplified, the expression  $(\sqrt[3]{m^4})(m^{-\frac{1}{2}})$  is equivalent to  
 A.  $\sqrt[3]{m^{-2}}$     B.  $\sqrt[4]{m^3}$   
 C.  $\sqrt[3]{m^{-4}}$     D.  $\sqrt[6]{m^5}$

- The expression  $x^{-\frac{2}{5}}$  is equivalent to  
 A.  $-\sqrt[2]{x^5}$     B.  $-\sqrt[5]{x^2}$     C.  $\frac{1}{\sqrt[2]{x^5}}$     D.  $\frac{1}{\sqrt[5]{x^2}}$
- Which is the equation of the graph below?  
 A.  $y = \log_2 x$   
 B.  $y = -\log_2 x$   
 C.  $y = 2^x$   
 D.  $y = 2^{-x}$

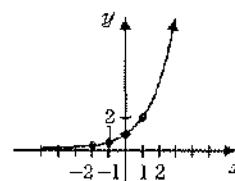

- Which equation is represented by the graph in the accompanying diagram?  
 A.  $y = \log x$   
 B.  $y = \log_2 x$   
 C.  $y = 2^x$   
 D.  $y = 10^x$
- The graph of the equation  $y = 10^x$  lies entirely in Quadrants  
 A. I and II    B. II and III  
 C. I and IV    D. III and IV

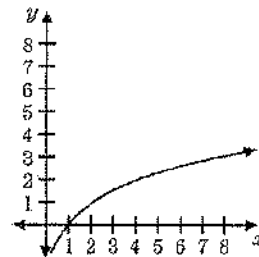

11. The accompanying graph represents the value of a bond over time. Which type of function does this graph best model?

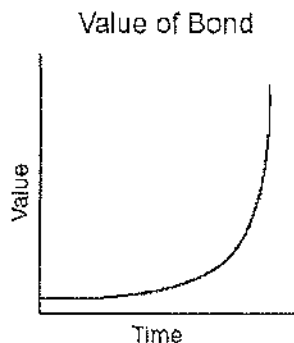

- A. trigonometric      B. logarithmic  
C. quadratic          D. exponential
12. The solution set of  $2^{x+1} = 8$  is
- A.  $\{ \}$     B.  $\{2\}$     C.  $\{3\}$     D.  $\{4\}$
13. What is the value of  $x$  in the equation  $3^{x-3} = 1$ ?
- A. 1    B.  $\frac{1}{3}$     C. 3    D. 0
14. What is the value of  $x$  in the equation  $81^{x+2} = 27^{5x+4}$ ?
- A.  $-\frac{2}{11}$     B.  $-\frac{3}{2}$     C.  $\frac{4}{11}$     D.  $-\frac{4}{11}$
15. What is the value of  $b$  in the equation  $4^{2b-3} = 8^{1-b}$ ?
- A.  $-\frac{3}{7}$     B.  $\frac{7}{9}$     C.  $\frac{9}{7}$     D.  $\frac{10}{7}$

16. The value of  $x$  in the equation  $4^{2x+5} = 8^{3x}$  is
- A. 1    B. 2    C. 5    D. -10
17. What is the value of  $x$  in the equation  $9^{3x+1} = 27^{x+2}$ ?
- A. 1    B.  $\frac{1}{3}$     C.  $\frac{1}{2}$     D.  $\frac{4}{3}$
18. The equation  $y = a^x$  expressed in logarithmic form is
- A.  $y = \log_a x$       B.  $a = \log_x y$   
C.  $x = \log_a y$       D.  $x = \log_y a$
19. Which equation is equivalent to  $y = 3^x$ ?
- A.  $\log 3 = x$       B.  $\log_y x = 3$   
C.  $\log_3 x = y$       D.  $\log_3 y = x$
20. The growth of bacteria in a dish is modeled by the function  $f(t) = 2^{\frac{t}{3}}$ . For which value of  $t$  is  $f(t) = 32$ ?
- A. 8    B. 2    C. 15    D. 16

21. Kathy deposits \$25 into an investment account with an annual rate of 5%, compounded annually. The amount in her account can be determined by the formula  $A = P(1 + R)^t$ , where  $P$  is the amount deposited,  $R$  is the annual interest rate, and  $t$  is the number of years the money is invested. If she makes no other deposits or withdrawals, how much money will be in her account at the end of 15 years?

- A. \$25.75                      B. \$43.75  
C. \$51.97                      D. \$393.97

22. Mr. Smith invested \$2,500 in a savings account that earns 3% interest compounded annually. He made no additional deposits or withdrawals. Which expression can be used to determine the number of dollars in this account at the end of 4 years?

- A.  $2500(1 + 0.03)^4$       B.  $2500(1 + 0.3)^4$   
C.  $2500(1 + 0.04)^3$       D.  $2500(1 + 0.4)^3$

23. Is the equation  $A = 21000(1 - 0.12)^t$  a model of exponential growth or exponential decay, and what is the rate (percent) of change per time period?

- A. exponential growth and 12%  
B. exponential growth and 88%  
C. exponential decay and 12%  
D. exponential decay and 88%

24. The current population of a town is 10,000. If the population,  $P$ , increases by 20% each year, which equation could be used to find the population after  $t$  years?

- A.  $P = 10,000(0.2)^t$       B.  $P = 10,000(0.8)^t$   
C.  $P = 10,000(1.2)^t$       D.  $P = 10,000(1.8)^t$

25. Find the solution set of the real numbers for the radical equation  $\sqrt{2x+1} = 1 + \sqrt{x}$ .

- A.  $\{0\}$                       B.  $\{0, -4\}$                       C.  $\{0, 4\}$   
D. none of these

26. Express  $\sqrt[3]{9} \cdot \sqrt[3]{81}$  in simple form.

- A.  $\sqrt[3]{128}$                       B.  $\sqrt[3]{128}$                       C. 9  
D. none of these

27. Solve:  $\sqrt{x^2 + 2} = 3$

- A.  $\pm\sqrt{5}$       B.  $\pm\sqrt{7}$       C.  $\pm 1$       D.  $\pm 5$

28. The number of real solutions of the equation  $\sqrt{2x+3} = x$  is:

- A. 1                      B. 2                      C. 3                      D. 4

29. The solution set of  $\sqrt{2x+1} = 1$  is:

- A.  $\{0, -1\}$                       B.  $\{0\}$   
C.  $\{ \}$  (the empty set)      D. none of these

30. Simplify:  $(3x^{-2}y^4)^{-3}$

- A.  $27xy$                       B.  $9x^2y^{12}$                       C.  $\frac{x^6}{27y^{12}}$   
D. none of these



31. Simplify:  $\frac{4x^3y^{-3}}{2x^3x^{-1}y^2}$

A.  $\frac{x^4}{2y^5}$

B.  $2x^2y^{-1}$

C.  $\frac{2x^4}{y}$

D. none of these

32. Simplify:  $\left(\frac{3x^{-3}}{5y^{-2}}\right)^{-2}$

A.  $\frac{25y^4}{9x^6}$

B.  $\frac{3x^5}{5y^4}$

C.  $\frac{25x^6}{9y^4}$

D. none of these

33. Simplify:  $\left(\frac{-4x^2}{3y}\right)^2 \cdot \left(\frac{5y^2}{6x}\right)^3$

A.  $\frac{4x^2y^2}{81}$

B.  $\frac{250xy^4}{243}$

C.  $\frac{10xy^4}{9}$

D. none of these

34. Simplify:  $(-4x^2y^{-3})^2(-2x^{-3}y^4)^{-3}$

A.  $\frac{2x^{13}}{y^{18}}$

B.  $\frac{-2y^{18}}{x^{13}}$

C.  $\frac{-2x^{13}}{y^{18}}$

D. none of these

35. Simplify:  $(4x^{-4}y^6)^{-\frac{1}{2}}(3x^3y^{-7})^{-2}$

A.  $\frac{xy}{12}$

B.  $\frac{12}{xy}$

C.  $\frac{y^{11}}{18x^4}$

D.  $\frac{9x^2}{2y^{12}}$

36.  $\left(\frac{a^{-3}b^2c^4}{a^{-5}b^4}\right)^{-\frac{1}{2}}$  is equivalent to which of the following?

A.  $a^{-1}bc^{-2}$

B.  $\frac{bc^2}{a}$

C.  $a^4b^3c^{-2}$

D.  $\frac{ab}{c^2}$

Final Exam Review, Unit 4

Name: \_\_\_\_\_

Date: \_\_\_\_\_

1. Which of the following functions of  $x$  has the apparent range of  $\{y : y \geq 0\}$ ?

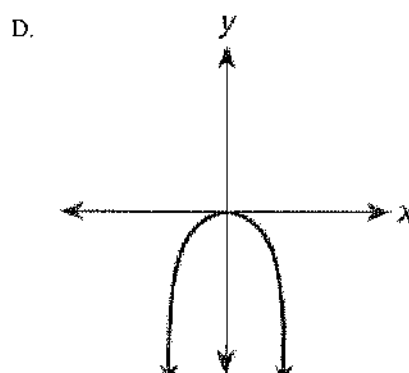
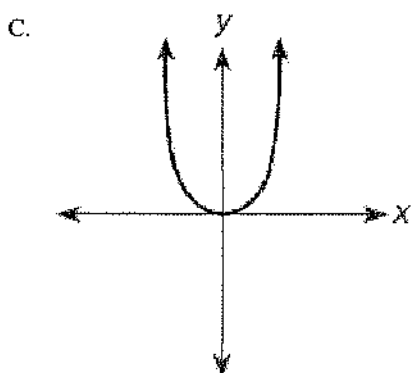
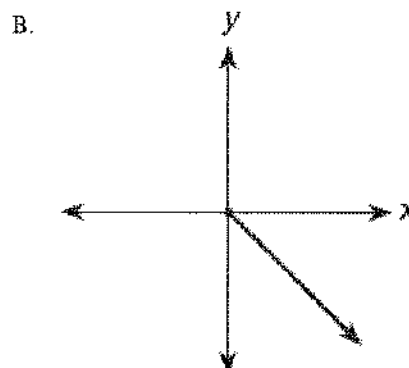
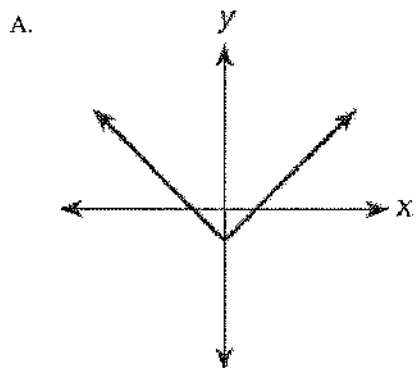

2. A rectangle has a width of  $4 - x$  units and a length of  $x$  units. The area of the rectangle is represented by the function  $A(x) = -x^2 + 4x$ , whose graph is shown.

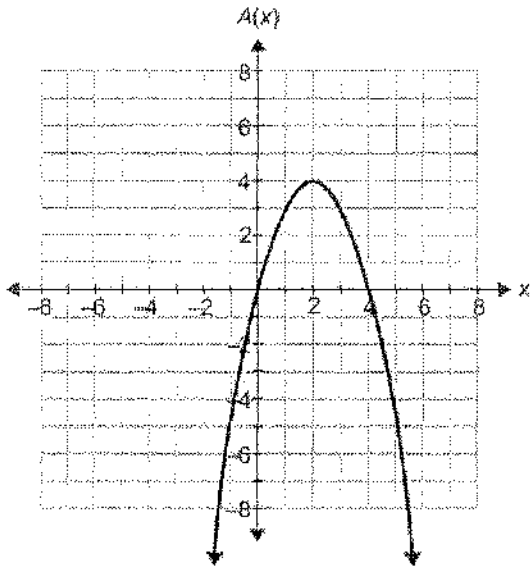

What is the domain of  $A(x)$  in this situation?

- A. All real numbers      B.  $-8 < x < 4$   
 C.  $0 \leq x < 4$       D.  $0 < x < 4$

3. Look at the function that is graphed below.

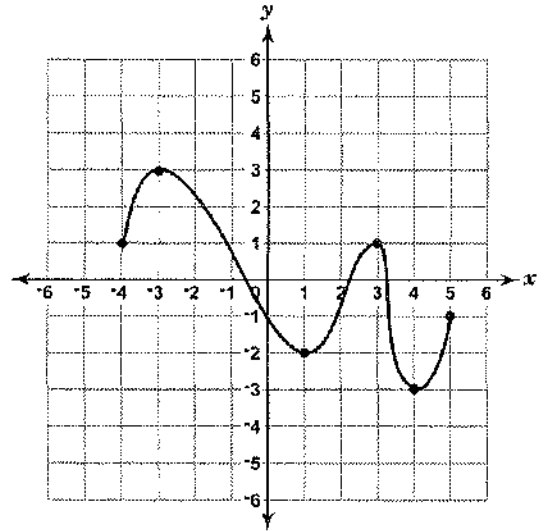

What is the range of this function?

- A.  $-4 \leq y \leq 5$       B.  $-3 \leq y \leq 3$   
 C.  $-2 \leq y \leq 3$       D.  $-4 \leq y \leq -1$

- 4.

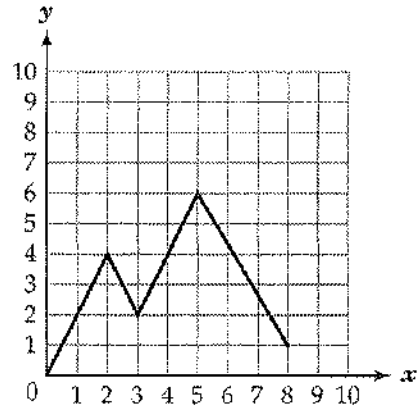

What is the domain of this function?

- A.  $0 \leq x \leq 5$       B.  $0 \leq x \leq 8$   
 C.  $0 \leq y \leq 1$       D.  $0 \leq y \leq 6$

5. Look at the function that is graphed below.

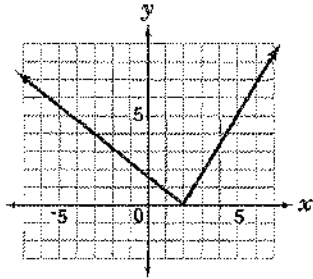

Which of these describes the range of this function?

- A.  $y \geq 0$                       B.  $0 \leq y \leq 5$   
C. all real numbers              D. all whole numbers

6. The vertex of the quadratic function shown on the grid below is at  $(0, -4)$ .

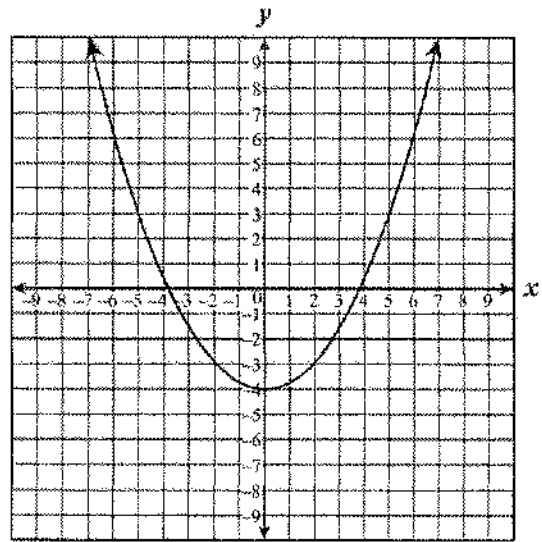

If the graph of this function is translated 2 units down, which of the following best describes the range of the resulting graph?

- A. All numbers greater than or equal to  $-6$   
B. All numbers less than or equal to  $-6$   
C. All numbers greater than or equal to  $-2$   
D. All real numbers

7. Which of the following graphs does *not* represent a function of  $x$ ?

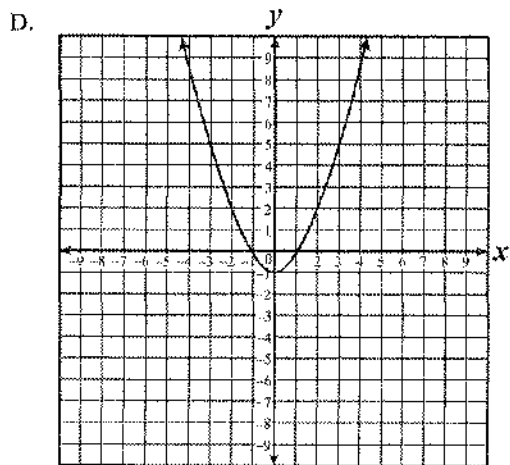
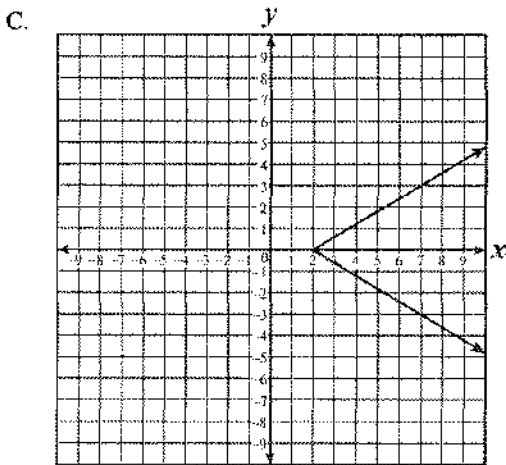
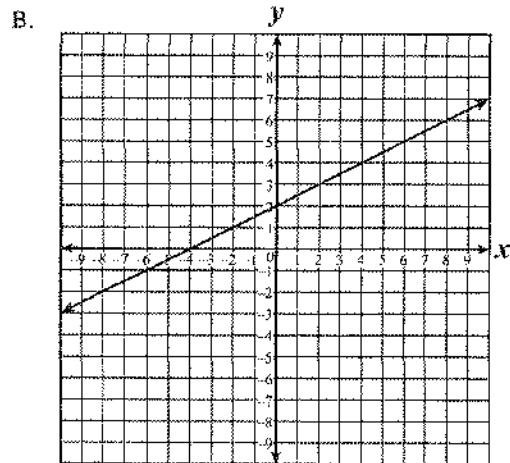
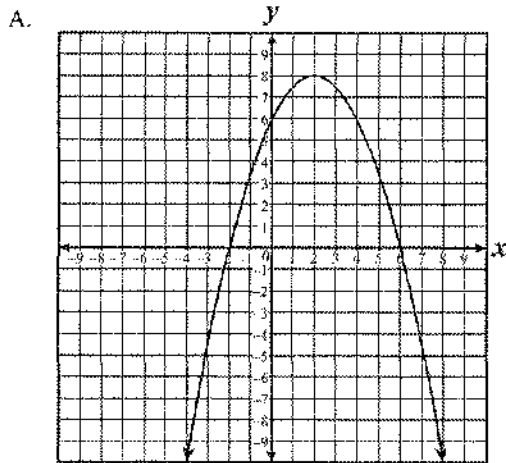

8. Look at this graph of a function. ( $y$  is a function of  $x$ .)

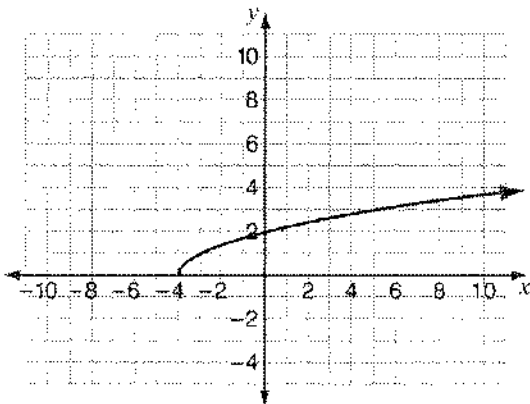

What is the domain of the function?

- A. all real numbers
- B. all real numbers except  $-4$
- C. all real numbers greater than or equal to  $0$
- D. all real numbers greater than or equal to  $-4$

9. The graph of a function is shown below.

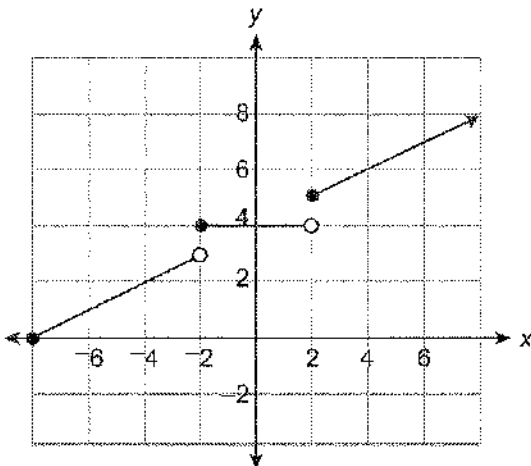

Which value is *not* in the range of the function?

- A.  $0$
- B.  $3$
- C.  $4$
- D.  $5$

10. A function is graphed below.

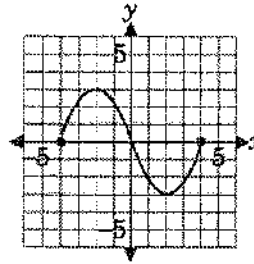

What is the domain of this function?

- A.  $-3 < y < 3$
- B.  $-4 \leq y \leq 4$
- C.  $-3 \leq x \leq 3$
- D.  $-4 \leq x \leq 4$

11. Which of the following expressions is equivalent to  $(6xy)^2$ ?

- A.  $12x^2y^2$
- B.  $6xy^2$
- C.  $36x^2y^2$
- D.  $6x^2y^2$

12. Which of the following is equivalent to the expression below?

$$(m + 1)(m + 5)$$

- A.  $2m + 6$
- B.  $m^2 + 5$
- C.  $m^2 + 5m + 6$
- D.  $m^2 + 6m + 5$

13. What is the inverse of the function  $y = 2x + 3$ ?

- A.  $x = \frac{1}{2}y - \frac{3}{2}$
- B.  $y = \frac{1}{2}x - \frac{3}{2}$
- C.  $y = 2x - 3$
- D.  $x = -2y - 3$

14. In the diagram at the right, the function  $f(x) = x^2$  is represented graphically. Which graph below represents the inverse of  $f(x)$ ?

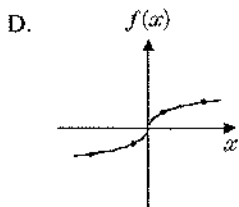
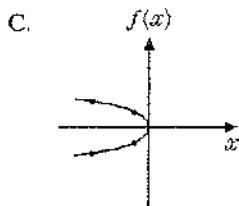
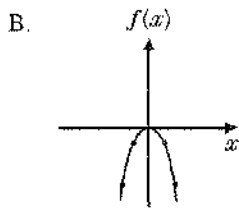
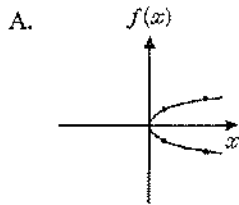
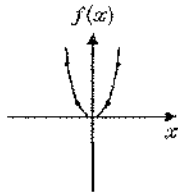

15. What is the inverse relation of the function whose equation is  $y = 3x - 2$ ?

- A.  $y = x$                       B.  $y = 3x + 2$   
 C.  $y = 2x - 3$                 D.  $y = \frac{x+2}{3}$

16. Which equation is represented by the accompanying graph?

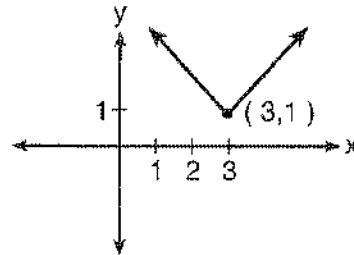

- A.  $y = |x| - 3$                       B.  $y = (x - 3)^2 + 1$   
 C.  $y = |x + 3| - 1$                 D.  $y = |x - 3| + 1$

17. The graph of  $y = |x + 2|$  is shown below.

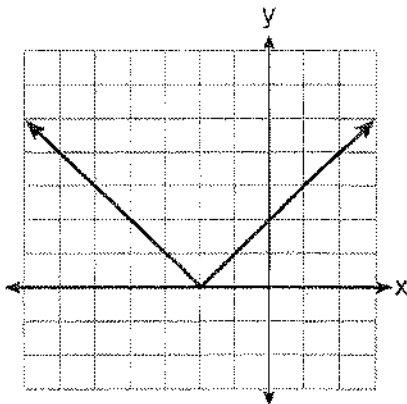

Which graph represents  $y = -|x + 2|$ ?

A.

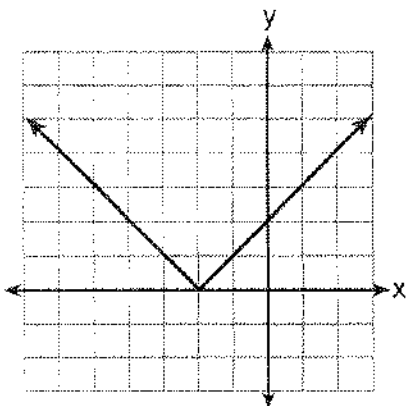

B.

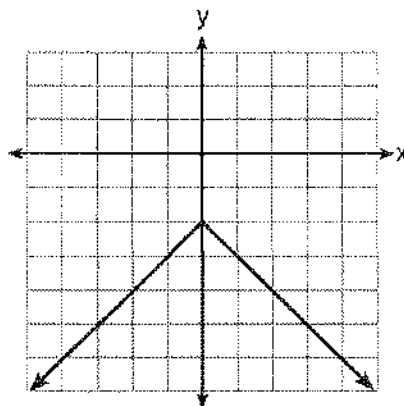

C.

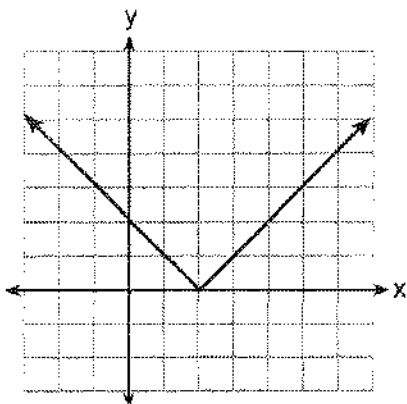

D.

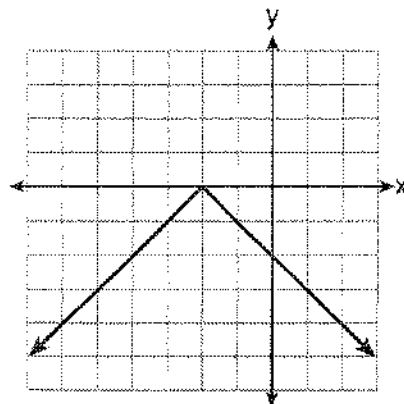



18. Which is an equation of the graph shown in the diagram?

- A.  $y = x^2 - 4$
- B.  $y = -x^2 + 4$
- C.  $x = y^2 - 4$
- D.  $x = -y^2 + 4$

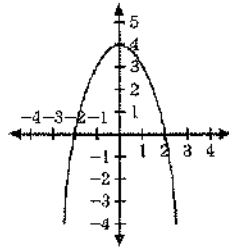

19. Which equation represents the parabola shown in the accompanying graph?

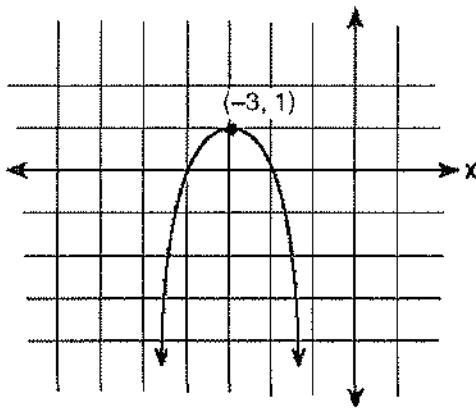

- A.  $f(x) = (x + 1)^2 - 3$
- B.  $f(x) = -(x - 3)^2 + 1$
- C.  $f(x) = -(x + 3)^2 + 1$
- D.  $f(x) = -(x - 3)^2 - 3$

20. Which of the following represents a graph  $y = \frac{1}{x}$ ?

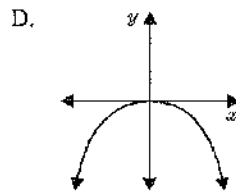
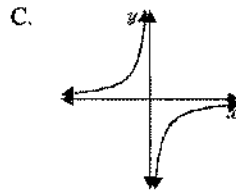
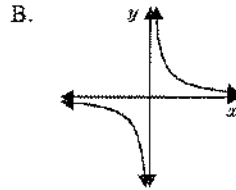
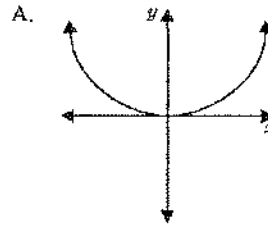

Final Exam Review, Unit 5

Name: \_\_\_\_\_

Date: \_\_\_\_\_

1. What is the amplitude of the graph of the equation  $y = 2 \sin \frac{1}{2}x$ ?

- A.  $\frac{1}{2}$     B. 2    C.  $\pi$     D.  $2\pi$

2. What is the amplitude of the graph of the equation  $y = 2 \cos 3x$ ?

- A.  $\frac{2\pi}{3}$     B. 2    C. 3    D.  $6\pi$

3. What is the amplitude of the graph whose equation is  $y = -4 \sin 2x$ ?

- A.  $\pi$     B. 2    C. -2    D. 4

4. Which is the graph of the equation  $y = -\sin x$ ?

- A.    B.
- C.    D.

5. Which is an equation of the graph shown below?

- A.  $y = \sin 2x$   
 B.  $y = 2 \cos x$   
 C.  $y = \cos 2x$   
 D.  $y = 2 \sin x$

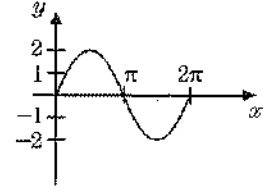

6. Which equation is represented on the accompanying graph?

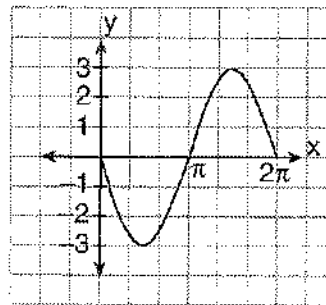

- A.  $y = 3 \sin x$     B.  $y = -3 \sin x$   
 C.  $y = 3 \cos x$     D.  $y = -\sin 3x$

7. In right triangle  $ABC$ ,  $m\angle C = 90$ ,  $m\angle A = 55$ , and  $CA = 10$ . What is the length of  $\overline{AB}$  to the nearest integer?

- A. 6    B. 14    C. 17    D. 24

8. In the accompanying diagram of right triangle  $RUN$ ,  $m\angle U = 90$ ,  $m\angle N = 37$ , and  $RN = 21$ .

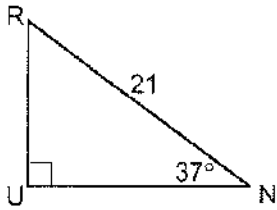

What is the length of  $\overline{RU}$ , expressed to the *nearest tenth*?

- A. 12.6    B. 15.8    C. 16.8    D. 34.9

9. In the right triangle shown in the diagram below, what is the value of  $x$  to the *nearest whole number*?

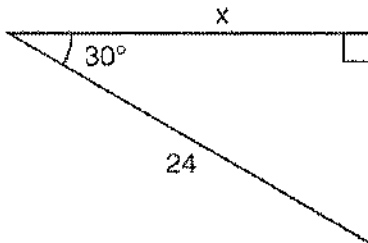

- A. 12    B. 14    C. 21    D. 28

10. A tree casts a 25-foot shadow on a sunny day, as shown in the diagram below.

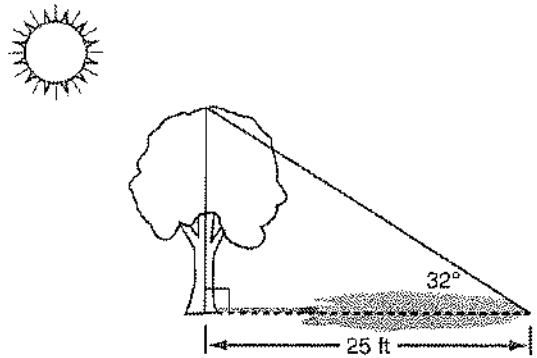

If the angle of elevation from the tip of the shadow to the top of the tree is  $32^\circ$ , what is the height of the tree to the *nearest tenth of a foot*?

- A. 13.2    B. 15.6    C. 21.2    D. 40.0

11. In right triangle  $ABC$  shown below,  $AB = 18.3$  and  $BC = 11.2$ .

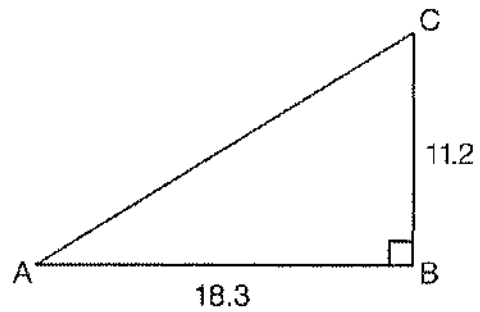

What is the measure of  $\angle A$ , to the *nearest tenth of a degree*?

- A. 31.5    B. 37.7    C. 52.3    D. 58.5

12. If  $a = 4$ ,  $b = 6$ , and  $\sin A = \frac{3}{5}$  in  $\triangle ABC$ , then  $\sin B$  equals

- A.  $\frac{3}{20}$     B.  $\frac{6}{10}$     C.  $\frac{8}{10}$     D.  $\frac{9}{10}$

13. In triangle  $ABC$ ,  $\sin A = 0.3$ ,  $\sin B = 0.4$ , and  $a = 12$ . Find  $b$ .

14. In  $\triangle ABC$ ,  $m\angle A = 75$ ,  $m\angle B = 40$ , and  $b = 35$ . What is the measure of side  $c$ ?

A.  $\frac{35 \sin 40^\circ}{\sin 65^\circ}$

B.  $\frac{35 \sin 75^\circ}{\sin 40^\circ}$

C.  $\frac{35 \sin 40^\circ}{\sin 75^\circ}$

D.  $\frac{35 \sin 65^\circ}{\sin 40^\circ}$

15. In  $\triangle ABC$ ,  $a = 4$ ,  $b = 3$ , and  $\cos C = -\frac{1}{2}$ . What is the length of  $c$ ?

A. 7      B.  $\sqrt{13}$       C.  $\sqrt{37}$       D.  $\sqrt{19}$

16. In triangle  $ABC$ ,  $a = 5$ ,  $b = 7$ , and  $c = 8$ . The measure of  $\angle B$  is

A.  $30^\circ$       B.  $60^\circ$       C.  $120^\circ$       D.  $150^\circ$

17. In a triangle, the sides measure 3, 5, and 7. What is the measure, in degrees, of the largest angle?

A. 60      B. 90      C. 120      D. 150

18. The area of  $\triangle ABC$  is 100 square centimeters. If  $c = 20$  centimeters and  $m\angle A = 30$ , then  $b$  is equal to

A. 20 cm

B. 500 cm

C.  $20\sqrt{3}$  cm

D.  $10\sqrt{2}$  cm

19. In  $\triangle ABC$ ,  $m\angle C = 30$  and  $a = 8$ . If the area of the triangle is 12, what is the length of side  $b$ ?

A. 6      B. 8      C. 3      D. 4

20. Given  $\triangle ABC$ ,  $AB = 6$ ,  $AC = 9$ , find  $BC$ .

A. 45      B.  $3\sqrt{5}$

C.  $5\sqrt{3}$       D. 117

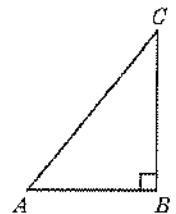

Unit 6 Final Review

Name: \_\_\_\_\_

Date: \_\_\_\_\_

1. A bag contains 2 red marbles and 3 blue marbles. If one marble is drawn at random, what is the probability that it is red?

A.  $\frac{1}{3}$     B.  $\frac{2}{5}$     C.  $\frac{3}{5}$     D.  $\frac{4}{3}$

2. If a letter is chosen at random from the word "BASEBALL," what is the probability that the letter chosen is not an L?

A.  $\frac{1}{8}$     B.  $\frac{2}{8}$     C.  $\frac{6}{8}$     D.  $\frac{7}{8}$

3. The probability of throwing two fours on a single toss of a pair of dice is

A.  $\frac{1}{36}$     B.  $\frac{1}{12}$     C.  $\frac{1}{6}$     D.  $\frac{1}{3}$

4. If two coins are tossed, the probability of getting two tails is

A.  $\frac{1}{2}$     B.  $\frac{1}{3}$     C.  $\frac{1}{4}$     D.  $\frac{1}{8}$

5. What is the value of  ${}_5P_1$ ?

A. 1    B. 5    C. 24    D. 120

6. The value of  ${}_9C_6$  is

A. 15    B. 54    C. 84    D. 504

7. John has 6 pairs of pants and 3 shirts. How many possible outfits consisting of one shirt and one pair of pants can he select?

A. 9    B. 2    C. 12    D. 18

8. If Debbie has 3 blouses and 4 skirts, how many different outfits of a blouse and skirt can she wear?

A. 12    B. 7    C. 3    D. 4

9. A cafeteria offers a choice of five sandwiches, three salads, and three beverages. How many different meals can be chosen if each meal consists of one sandwich, one salad, and one beverage?

A. 1    B. 5    C. 11    D. 45

10. How many different 6-letter arrangements can be formed using the letters in the word "ABSENT," if each letter is used only once?

A. 6    B. 36  
C. 720    D. 46,656

11. Which expression represents the number of different 8-letter arrangements that can be made from the letters of the word "SAVANNAH" if each letter is used only once?

A.  $\frac{8!}{5!}$     B.  $\frac{8!}{3!2!}$     C.  ${}_8P_5$     D.  $8!$

12. How many different two-letter arrangements can be formed using the letters in the word "BROWN"?

A. 10    B. 12    C. 20    D. 25

13. How many different four-letter arrangements are possible with the letters *G, A, R, D, E, N* if each letter may be used only once?

A. 15    B. 24    C. 360    D. 720

14. How many different three-member teams can be formed from six students?

A. 20    B. 120    C. 216    D. 720

15. The principal would like to assemble a committee of 8 students from the 15-member student council. How many different committees can be chosen?

A. 120                      B. 6,435  
C. 32,432,400              D. 259,459,200

16. There are 18 students in a class. Each day, the teacher randomly selects three students to assist in a game: a leader, a recorder, and a timekeeper. In how many possible ways can the jobs be assigned?

A. 306    B. 816    C. 4896    D. 5832

17. If two fair dice are tossed once, the probability of getting 12 is  $\frac{1}{36}$ . What is the probability of not getting 12?

A.  $\frac{35}{36}$     B.  $\frac{30}{36}$     C.  $\frac{6}{36}$     D.  $\frac{34}{36}$

18. The spinner below is divided into eight equal regions and is spun once. What is the probability of *not* getting red?

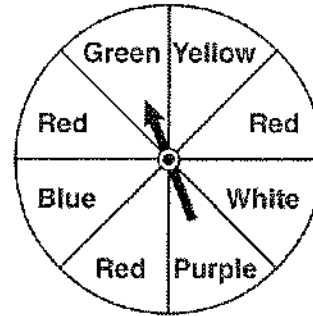

A.  $\frac{3}{5}$     B.  $\frac{3}{8}$     C.  $\frac{5}{8}$     D.  $\frac{7}{8}$

19. A single card is drawn from a standard deck of 52 cards. What is the probability the card is a five or a diamond?

A.  $\frac{17}{52}$     B.  $\frac{15}{32}$     C.  $\frac{16}{52}$     D.  $\frac{18}{52}$

20. An urn contains five red marbles, four green marbles, and three blue marbles. If one marble is drawn at random, what is the probability that it is either a green marble or a blue marble?

A.  $\frac{5}{12}$     B.  $\frac{3}{12}$     C.  $\frac{7}{12}$     D.  $\frac{4}{12}$

21. An urn contains three red marbles and four blue marbles. One marble is selected at random, its color is noted, and it is returned to the urn. Another marble is then selected. What is the probability the second marble drawn is red?

A.  $\frac{1}{7}$     B.  $\frac{2}{7}$     C.  $\frac{3}{7}$     D.  $\frac{3}{6}$

22. If two cards are drawn from a standard deck of 52 cards without replacement, what is the probability that both cards are fives?

A.  $\frac{2}{52}$                       B.  $\frac{4}{52} \cdot \frac{3}{51}$   
 C.  $\frac{1}{4} \cdot \frac{1}{3}$                       D.  $\frac{5}{52} \cdot \frac{4}{51}$

23. A bag of marbles contains three blue, one black, and four yellow marbles. If two marbles are chosen at random without replacement, what is the probability that both marbles will be yellow?

A.  $\frac{3}{14}$       B.  $\frac{7}{36}$       C.  $\frac{1}{3}$       D.  $\frac{1}{4}$

24. An urn contains four red marbles and five blue marbles. What is the probability of selecting at random, without replacement, two blue marbles?

A.  $\frac{20}{81}$       B.  $\frac{16}{81}$       C.  $\frac{20}{72}$       D.  $\frac{16}{72}$

25. A gumball machine contains six yellow gumballs and five orange gumballs. What is the probability of obtaining, at random and without replacement, two yellow gumballs?

A.  $\frac{36}{110}$       B.  $\frac{36}{121}$       C.  $\frac{30}{110}$       D.  $\frac{30}{121}$

26. Keisha is playing a game using a wheel divided into eight equal sectors, as shown in the diagram below. Each time the spinner lands on orange, she will win a prize.

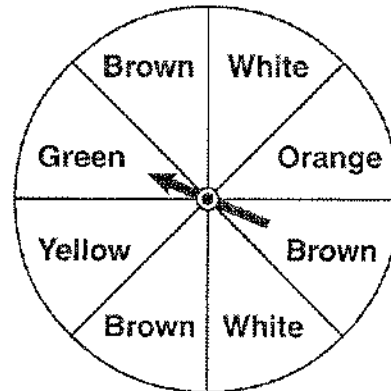

If Keisha spins this wheel twice, what is the probability she will win a prize on *both* spins?

A.  $\frac{1}{64}$       B.  $\frac{1}{36}$       C.  $\frac{1}{16}$       D.  $\frac{1}{4}$

27. A newspaper poll was taken to determine the probable winner in an election for mayor. The probability that Andrews will win is 0.4, while the probability that Egan will win is 0.3. What is the probability that either Andrews or Egan will win?

A. 0.7      B. 0.12      C. 0.3      D. 0.4

28. When a number is chosen at random from the set {1, 2, 3, 4, 5, 6}, which event has the greatest probability of occurring?

- A. choosing an even number  
 B. choosing a prime number  
 C. choosing a number greater than 3  
 D. *not* choosing either 1 or 6

29. The probability that a red block is selected from a bucket is  $\frac{3}{8}$ , and the probability that a blue block is selected is  $\frac{2}{8}$ . What is the probability that a red block or a blue block is selected?

- A. 1      B.  $\frac{1}{2}$       C.  $\frac{5}{8}$       D.  $\frac{6}{8}$

30. The party registration of the voters in Jonesville is shown in the table.

Registered Voters in Jonesville	
Party Registration	Number of Voters Registered
Democrat	6,000
Republican	5,300
Independent	3,700

If one of the registered Jonesville voters is selected at random, what is the probability that the person selected is *not* a Democrat?

- A. 0.333    B. 0.400    C. 0.600    D. 0.667