



Georgia Standards of Excellence Frameworks

Mathematics

GSE Pre-Calculus

Unit 1: Introduction to Trigonometric
Functions



Richard Woods, Georgia's School Superintendent
"Educating Georgia's Future"

Unit 1

Trigonometric Functions

Table of Contents

OVERVIEW	3
STANDARDS ADDRESSED IN THIS UNIT	4
STANDARDS FOR MATHEMATICAL PRACTICE	5
ENDURING UNDERSTANDINGS	5
ESSENTIAL QUESTIONS	5
CONCEPTS AND SKILLS TO MAINTAIN	6
SELECT TERMS AND SYMBOLS	6
EVIDENCE OF LEARNING	7
FORMATIVE ASSESSMENT LESSONS (FAL)	8
SPOTLIGHT TASKS	8
TASKS	9
Clock Problem	11
Figuring Out All the Angles	20
Real Numbers and the Unit Circle	37
Trigonometric Functions on the Unit Circle	65
UnWrapping the Unit Circle	73
Exploring Sine and Cosine Graphs	83
A Better Mouse Trap (Spotlight Task)	96
Formative Assessment Lesson: Ferris Wheel	131
As the Wheel Turns	132
Transforming Sinusoidal Graphs	138
Modeling with Sinusoidal Functions	149
Discovering a Pythagorean Identity	164
Cuminating Task: Graphing Other Trigonometric Functions	171

***Revised standards indicated in bold red font.**

OVERVIEW

In this unit students will:

- Expand their understanding of angle with the concept of a rotation angle
- Explore the definition of radian
- Define angles in standard position and consider them in relationship to the unit circle
- Make connections to see how a real number is connected to the radian measure of an angle in standard position which is connected to an intercepted arc on the unit circle which is connected to a terminal point of this arc whose coordinates are connected to the sine and cosine functions
- Gain a better understanding of the unit circle and its connection to trigonometric functions. Develop an understanding of the graphs of the sine and cosine functions and learn to recognize the basic characteristics of their graphs
- Realize transformations of $y = \sin(x)$ and $y = \cos(x)$ behave just as transformations of other parent functions
- Learn that the concepts of amplitude, midline, frequency, and period are related to the transformations of trigonometric functions
- Learn how to look at a graph of a transformed sine or cosine function and to write a function to represent that graph explore several real-world settings and represent the situation with a trigonometric function that can be used to answer questions about the situation.
- Develop and use the Pythagorean identity $(\sin t)^2 + (\cos t)^2 = 1$ is developed and used to solve problems.

Although the units in this instructional framework emphasize key standards and big ideas at specific times of the academic year, routine topics such as estimation, mental computation, and basic computation facts should be addressed on an ongoing basis. Ideas related to the eight practice standards should be addressed constantly as well. To assure that this unit is taught with the appropriate emphasis, depth, and rigor, it is important that the tasks listed under “Evidence of Learning” be reviewed early in the planning process. This unit provides much needed content information and excellent learning activities, but a variety of supplementary resources should be utilized. The tasks in this unit illustrate the types of learning activities that should be utilized from a variety of sources.

STANDARDS ADDRESSED IN THIS UNIT

Mathematical standards are interwoven and should be addressed throughout the year in as many different units and activities as possible in order to emphasize the natural connections that exist among mathematical topics.

KEY STANDARDS

Interpret functions that arise in applications in terms of the context

MGSE9-12.F.IF.4 Using tables, graphs, and verbal descriptions, interpret the key characteristics of a function which models the relationship between two quantities. Sketch a graph showing key features including: intercepts; interval where the function is increasing, decreasing, positive, or negative; relative maximums and minimums; symmetries; end behavior; and periodicity.

Analyze functions using different representations

MGSE9-12.F.IF.7 Graph functions expressed algebraically and show key features of the graph both by hand and by using technology.

MGSE9-12.F.IF.7e Graph ~~exponential and logarithmic functions, showing intercepts and end behavior, and~~ trigonometric functions, showing period, midline, and amplitude.

Extend the domain of trigonometric functions using the unit circle

MGSE9-12.F.TF.1 Understand radian measure of an angle as the length of the arc on the unit circle subtended by the angle.

MGSE9-12.F.TF.2 Explain how the unit circle in the coordinate plane enables the extension of trigonometric functions to all real numbers, interpreted as radian measures of angles traversed counterclockwise around the unit circle.

Model periodic phenomena with trigonometric functions

MGSE9-12.F.TF.5 Choose trigonometric functions to model periodic phenomena with specified amplitude, frequency, and midline.

Prove and apply trigonometric identities

MGSE9-12.F.TF.8 Prove the Pythagorean identity $(\sin A)^2 + (\cos A)^2 = 1$ and use it to find $\sin A$, $\cos A$, or $\tan A$, given $\sin A$, $\cos A$, or $\tan A$, and the quadrant of the angle.

STANDARDS FOR MATHEMATICAL PRACTICE

Refer to the Comprehensive Course Overview for more detailed information about the Standards for Mathematical Practice.

1. Make sense of problems and persevere in solving them.
2. Reason abstractly and quantitatively.
3. Construct viable arguments and critique the reasoning of others.
4. Model with mathematics.
5. Use appropriate tools strategically.
6. Attend to precision.
7. Look for and make use of structure.
8. Look for and express regularity in repeated reasoning.

ENDURING UNDERSTANDINGS

- An angle can be thought of as the rotation of a ray about its endpoint.
- Angles can be measured in degrees and in radians.
- Trigonometric functions are extended to the set of real numbers when we relate a real number to a point on the unit circle.
- Trigonometric functions can be used to model periodic phenomena.

ESSENTIAL QUESTIONS

- How do I think of an angle as the rotation of a ray about its endpoint?
- What is meant by the radian measure of an angle?
- What is the connection between the radian measure of an angle and the length of the arc on the unit circle the angle intercepts?
- What does the unit circle have to do with trigonometric functions?
- If I know the characteristics of the graph of a sinusoidal function, how can I write an equation for that graph?
- How can we model a real-world situation with a trigonometric function?
- How are the amplitude, midline, period, and frequency of a trigonometric function related to the transformation of the parent graph?

CONCEPTS AND SKILLS TO MAINTAIN

In order for students to be successful, the following skills and concepts need to be maintained:

- Understand and be able to explain what a function is.
- Determine if a table, graph or set of ordered pairs is a function.
- Be able to express geometric properties with an equation.
- Understand fractional relationships.

SELECT TERMS AND SYMBOLS

The following terms and symbols are often misunderstood. These concepts are not an inclusive list and should not be taught in isolation. However, due to evidence of frequent difficulty and misunderstanding associated with these concepts, instructors should pay particular attention to them and how their students are able to explain and apply them.

The definitions below are for teacher reference only and are not to be memorized by the students. Students should explore these concepts using models and real life examples. Students should understand the concepts involved and be able to recognize and/or demonstrate them with words, models, pictures, or numbers.

The websites below are interactive and include a math glossary suitable for high school children. Note – At the high school level, different sources use different definitions. Please preview any website for alignment to the definitions given in the frameworks

<http://www.amathsdictionaryforkids.com/>

This web site has activities to help students more fully understand and retain new vocabulary.

<http://intermath.coe.uga.edu/dictionary/homepg.asp>

Definitions and activities for these and other terms can be found on the Intermath website. Intermath is geared towards middle and high school students.

- An angle is in **standard position** when the vertex is at the origin and the initial side lies on the positive side of the x-axis.
- The ray that forms the **initial side** of the angle is rotated around the origin with the resulting ray being called the **terminal side** of the angle.
- An angle is **positive** when the location of the terminal side results from a counterclockwise rotation. An angle is **negative** when the location of the terminal side results from a clockwise rotation.

Georgia Department of Education
Georgia Standards of Excellence Framework
GSE Pre-Calculus • Unit 1

- Angles are called **coterminal** if they are in standard position and share the same terminal side regardless of the direction of rotation.
- The **reference number** t' associated with a real number t is the shortest distance along the unit circle between the terminal point determined by t and the x -axis. The reference number is always positive.
- The **unit circle** is a circle with a radius of 1 and center at the origin.
- If a central angle in a circle intercepts an arc equal to the length of the radius of the circle, the measure of the angle is **1 radian**.
- An **identity** is an equation that is true for all values of the variable for which the expressions in the equation are defined.
- A function is a **sinusoidal function** if its graph has the shape of $y = \sin(x)$ or a transformation of $y = \sin(x)$.
- The **midline** of the graph of a sinusoidal function is a horizontal line located halfway between the maximum and minimum values.
- The **amplitude** of the graph of a sinusoidal function is the distance from the midline to either the maximum or minimum value. The amplitude is $\frac{1}{2}$ the distance between the maximum and minimum values.
- The **period** of a trigonometric function is the horizontal length of one complete cycle. It is the distance between any two repeating points on the function.
- The **frequency** of a trigonometric function is the number of cycles the function completes in a given interval. The frequency is defined to be the reciprocal of the period.

EVIDENCE OF LEARNING

By the conclusion of this unit, students should be able to demonstrate the following competencies:

- Explain what is meant by the radian measure of an angle.
- Define the trigonometric functions in terms of a point on the unit circle.
- Be able to determine the trigonometric values of one of the special real numbers by using the reference number of that real number.
- Be able to graph a trigonometric function and identify its characteristics.
- Know what is meant by the amplitude, the period, and the phase shift of a trigonometric function.
- Be able to write an equation of a trigonometric function given the characteristics of that function.
- Be able to explain why $(\sin t)^2 + (\cos t)^2 = 1$ is an identity and use it to solve problems.

FORMATIVE ASSESSMENT LESSONS (FAL)

Formative Assessment Lessons are intended to support teachers in formative assessment. They reveal and develop students' understanding of key mathematical ideas and applications. These lessons enable teachers and students to monitor in more detail their progress towards the targets of the standards. They assess students' understanding of important concepts and problem solving performance, and help teachers and their students to work effectively together to move each student's mathematical reasoning forward.

More information on Formative Assessment Lessons may be found in the Comprehensive Course Overview.

SPOTLIGHT TASKS

A Spotlight Task has been added to each GSE mathematics unit in the Georgia resources for middle and high school. The Spotlight Tasks serve as exemplars for the use of the Standards for Mathematical Practice, appropriate unit-level Common Core Georgia Performance Standards, and research-based pedagogical strategies for instruction and engagement. Each task includes teacher commentary and support for classroom implementation. Some of the Spotlight Tasks are revisions of existing Georgia tasks and some are newly created. Additionally, some of the Spotlight Tasks are 3-Act Tasks based on 3-Act Problems from Dan Meyer and Problem-Based Learning from Robert Kaplinsky.

Georgia Department of Education
 Georgia Standards of Excellence Framework
GSE Pre-Calculus • Unit 1

TASKS

Task Name	Task Type Grouping Strategy	Content Addressed	Standards for Mathematical Practice Addressed
Clock Problem	Scaffolding Task Individual/Partner	Characteristics of periodic functions	1,4
Figuring Out All the Angles	Learning Task Partner/Small Group	Angle as the rotation of a ray about its endpoint Determining angle measure in terms of the amount of rotation Develop the concept of radian measure	1, 2, 3, 4, 5, 6
Real Numbers and the Unit Circle	Learning Task Partner/Small Group	Connect real numbers to points on the unit circle Determine the points on the unit circle for some special real numbers Develop the concept of reference number and use it to determine the terminal point associated with a real number	1-8
Trigonometric Functions on the Unit Circle	Learning Task Partner/Small group	Define trigonometric functions in terms of the unit circle Use the unit circle to determine the trigonometric values of a real number	1-8
UnWrapping the Unit Circle	Learning Task Individual/Partner	Generate the graphs of the sine and cosine functions Identify the characteristics of the sine and cosine functions	1-8
Exploring Sine and Cosine Graphs	Learning Task Partner/Small group	The concepts of amplitude, midline, period, and frequency are identified and defined . The domain, range, intercepts, maximum and minimum values of sinusoidal graphs are determined.	1-8
A Better Mouse Trap (Spotlight Task)	Discovery/Learning Task Partner/Small group	Explores transformations of sinusoidal functions in terms of real-world phenomena.	1-8
Ferris Wheel (FAL)	Formative Assessment Lesson Individual/Small	Application of Sine and Cosine Graphs to Real-World Phenomena with	4, 7

Georgia Department of Education
 Georgia Standards of Excellence Framework
GSE Pre-Calculus • Unit 1

	group	Transformations	
As the Wheel Turns	Individual/Small group	Application and Extension on Sine and Cosine Graphs	1-8
Transforming Sinusoidal Graphs	Learning Task Partner/Small group	The effects of a , b , c , and d on the graphs of $y = a \sin[b(x - c)] + d$ and $y = a \cos[b(x - c)] + d$ are determined.	1-8
Modeling with Sinusoidal Functions	Learning Task Partner/Small group	Write an equation to represent a real-world situation.	1-8
Discovering a Pythagorean Identity	Individual Learning Task	Discover the Pythagorean Identity	1-8
Graphing Other Trigonometric Functions	Culminating Task Partner/Small group	Graph the tangent, cosecant, secant, and cotangent functions using their definitions and relationship to the sine and cosine graphs.	1-8

An end of unit balanced assessment with some constructed response, multiple choice, and technology modeling activities should be administered to thoroughly assess mastery of the standards in this unit.

Clock Problem¹

Mathematical Goals

- Collect data and represent with a graph
- Determine if a relationship represents a function
- Identify characteristics of a graph

Georgia Standards of Excellence

MGSE9-12.F.IF.7e Graph exponential and logarithmic functions, showing intercepts and end behavior, and trigonometric functions, showing period, midline, and amplitude.

Standards for Mathematical Practice

- Make sense of problems and persevere in solving them.
- Model with mathematics.

Introduction

In this task students explore the relationship between the number of hours since 6:00 and the distance from the tip of the hour hand on a wall clock to the ceiling. This problem serves to introduce students to some of the characteristics of the graph of a sinusoidal function. It is an easy problem to understand and to collect data. If student work is saved, the problem can be revisited later in the unit so students can write the function that models their data.

Remind students that the distance from a point to a line is defined as the length of the perpendicular segment from the point to the line.

Materials

- Toothpicks
- Centimeter rulers
- Clock and ceiling drawing

The hands of a clock on a wall move in a predictable way. As time passes, the distance between the ceiling and the tip of the hour hand changes. Suppose we want to investigate how this distance has changed since 6 o'clock. Let's simulate the situation using a clock with a toothpick for the hour hand and measuring the distance between the tip of the hour hand and a line representing the ceiling.

Allow students to collect the data and begin work on the above questions. Once everyone at least has a scatter plot of the data begin to discuss questions 1 through 5 with the class.

¹Adapted from *Math Connections: A Secondary Mathematics Core Curriculum* by Berlinghoff, W.P., Sloyer, C., & Wood. E.F. Armonk, NY: It's About Time, Inc. (2000).

The relationship is a function because for each number of hours since 6:00 there is a unique distance from the tip of the hour hand to the ceiling.

The number of hours since 6:00 is the independent variable and the distance from tip of the hour hand to the ceiling is the dependent variable.

Do students see the output values repeat? Can they explain why?

Do they see the maximum output value occurs when the input is 0 and the minimum output occurs when the input is 6? Thus, the range will be all real numbers between the minimum value and maximum value, inclusive. The domain will be all real numbers. They should recognize that negative values are appropriate; for ex., an input of -1 just corresponds to the time of 5:00 that occurred 1 hour before they began measuring.

Can students explain why there may be differences in the data collected from one pair to another? Their measurements depend upon the length of their toothpick as well as how accurately and precisely they measured. Remind students measurement is always an approximation.

Students may be inclined to connect the minimum and maximum points with a segment. However, the rate of change is not constant so a linear relationship is not appropriate (encourage students to see that the change in distance from 0 to 1 hours is not equal to the change in distance from 1 to 2 hours or from 2 to 3 hours--there is not a constant rate of change). Thus, the graph is that of a smooth curve that is somewhat flatter near the extreme points and somewhat steeper away from its extreme points.

Be sure students understand why the domain is the set of real numbers and what the graph will look like as the function is graphed over all its domain.

Explain this graph belongs to a family of sinusoidal functions whose characteristics we will explore in more detail later in this unit. (Go to <http://howjsay.com/index.php?word=sinusoidal> to hear correct pronunciation of "sinusoidal.") For now, use the graph of the clock data to explain informally concepts such as cycle, amplitude, midline, period, and frequency. It is suggested that the data and scatterplots are kept so students can write a function to model their data later in the unit.

Georgia Department of Education
Georgia Standards of Excellence Framework
GSE Pre-Calculus • Unit 1

Directions:

Work in pairs. You will need a ruler, graph paper, the sheet with the clock and the ceiling, and a toothpick.

Measure the length of your clock's hour hand (toothpick) to the nearest tenth of a centimeter and record it here. _____

Measure the distance from the tip of the hour hand to the ceiling for each of the number of hours since 6:00 given in the table. To what time does an input of 0 in the table correspond? To what time does an input of 1 in the table correspond?

Record your data in the table. *Given is a set of data for a toothpick of length 5.6 cm.*

Hrs since 6:00	0	1	2	3	4	5	6	7	8	9	10	11	12	13
Dist to the ceiling (cm)	<i>17.1</i>	<i>16.2</i>	<i>14.3</i>	<i>11.1</i>	<i>8.4</i>	<i>6.3</i>	<i>5.5</i>	<i>6.3</i>	<i>8.4</i>	<i>11.1</i>	<i>14.3</i>	<i>16.2</i>	<i>17.1</i>	<i>16.2</i>

Questions:

1. On graph paper construct a scatter plot of the data you collected. Label the axes appropriately and choose an appropriate scale. What do you observe about the data you collected?

Georgia Department of Education
Georgia Standards of Excellence Framework
GSE Pre-Calculus • Unit 1

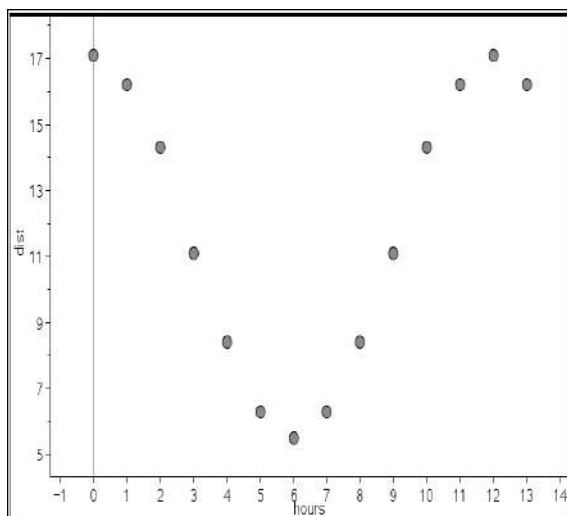

For the sample data shown:

The minimum value is 5.5 and the maximum value is 17.1.

The midline is a horizontal line located halfway between the minimum and maximum values so it is $y = 11.3$.

Encourage students to suggest several ways to determine this line; for example: the average of the maximum and minimum values is 11.3 the distance between the minimum and maximum values is $17.1 - 5.5 = 16.6$ so the midline is located 8.3 units below the maximum or 8.3 units above the minimum value.

The graph of the data with its midline (in pink) is shown below.

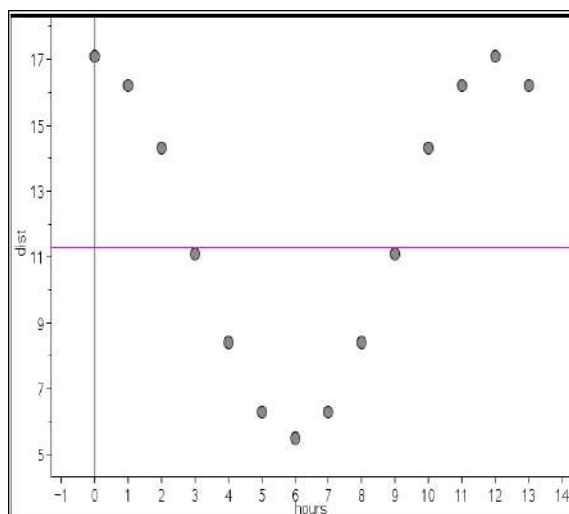

The amplitude is the distance between the midline and the maximum (or minimum) value. So the amplitude is 5.8.

One cycle of the graph occurs from 0 hours to 12 hours so we say the period of the function is 12 hours. The period is the horizontal length of one complete cycle.

The frequency is the number of cycles a graph completes in a given interval. More specifically the frequency is the reciprocal of the period so in this case the frequency is $1/12$. This means $1/12$ of a cycle is completed in 1 hour (i.e., in 1 unit of time).

2. Explain why the relationship between the number of hours since 6:00 and the distance from the tip of the hour hand to the ceiling is a function.

3. Which variable is the dependent variable? the independent variable?

4. What observations can you make about the function? What patterns do you observe? What is the domain? What is the range?

5. Explain why it makes sense to connect the points on your scatter plot and decide the most appropriate way to connect the points. Explain your thinking.

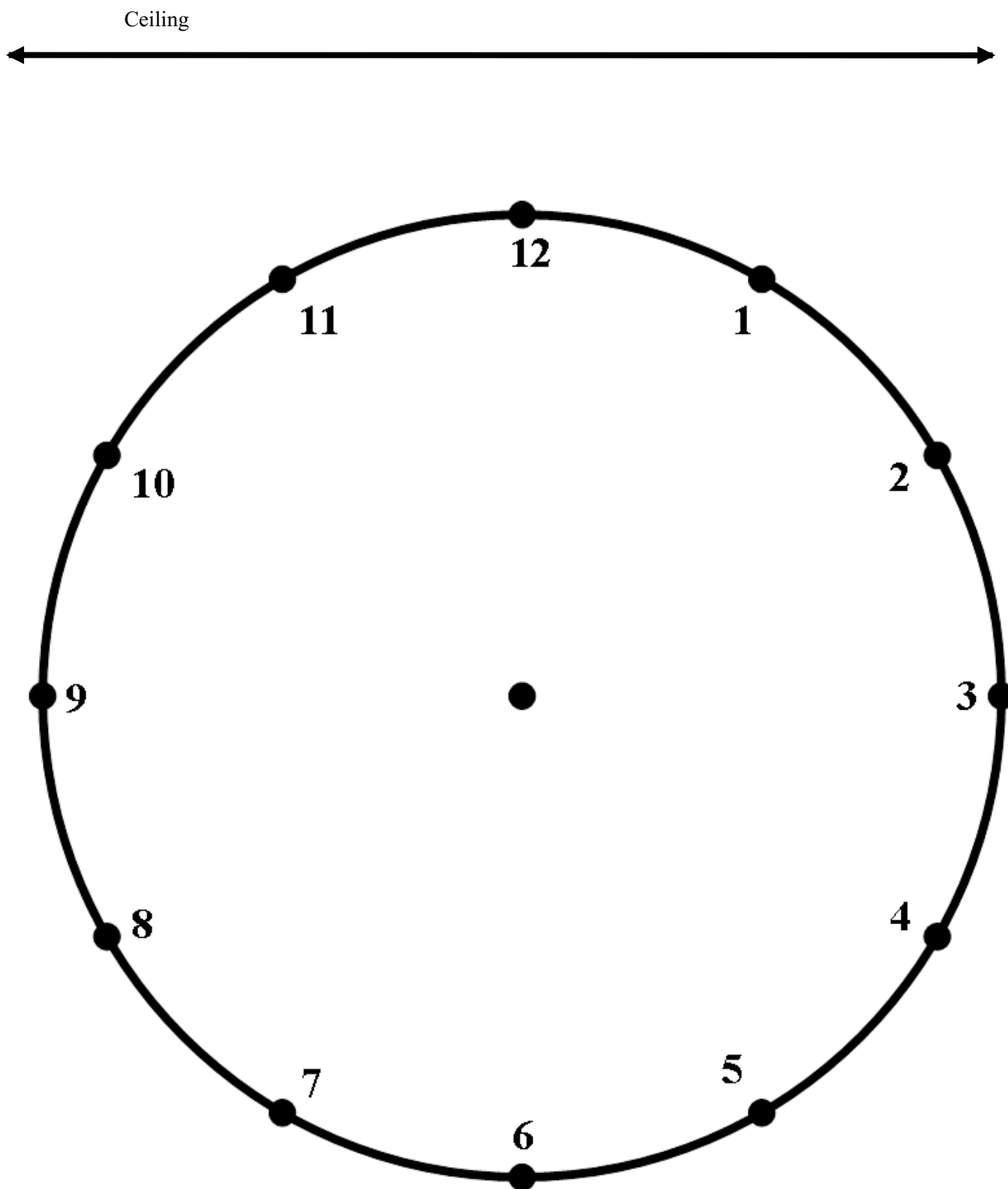

Clock Problem²

The hands of a clock on a wall move in a predictable way. As time passes, the distance between the ceiling and the tip of the hour hand changes. We want to investigate how this distance has changed since 6 o'clock. Let's simulate the situation using a clock with a toothpick for the hour hand and measuring the distance between the tip of the hour hand and a line representing the ceiling.

Directions:

Work in pairs. You will need a ruler, graph paper, the sheet with the clock and the ceiling, and a toothpick.

Measure the length of your clock's hour hand (toothpick) to the nearest tenth of a centimeter and record it here. _____

Measure the distance from the tip of the hour hand to the ceiling for each of the number of hours since 6:00 given in the table. To what time does an input of 0 in the table correspond? To what time does an input of 1 in the table correspond?

Record your data in the table.

Hrs since 6:00	0	1	2	3	4	5	6	7	8	9	10	11	12	13
Dist to the ceiling (cm)														

²Adapted from *Math Connections: A Secondary Mathematics Core Curriculum* by Berlinghoff, W.P., Sloyer, C., & Wood. E.F. Armonk, NY: It's About Time, Inc. (2000).

Georgia Department of Education
Georgia Standards of Excellence Framework
GSE Pre-Calculus • Unit 1

Questions:

1. On graph paper construct a scatter plot of the data you collected. Label the axes appropriately and choose an appropriate scale. What do you observe about the data you collected?
2. Explain why the relationship between the number of hours since 6:00 and the distance from the tip of the hour hand to the ceiling is a function.
3. Which variable is the dependent variable? the independent variable?
4. What observations can you make about the function? What patterns do you observe? What is the domain? What is the range?
5. Explain why it makes sense to connect the points on your scatter plot and decide the most appropriate way to connect the points. Explain your thinking.

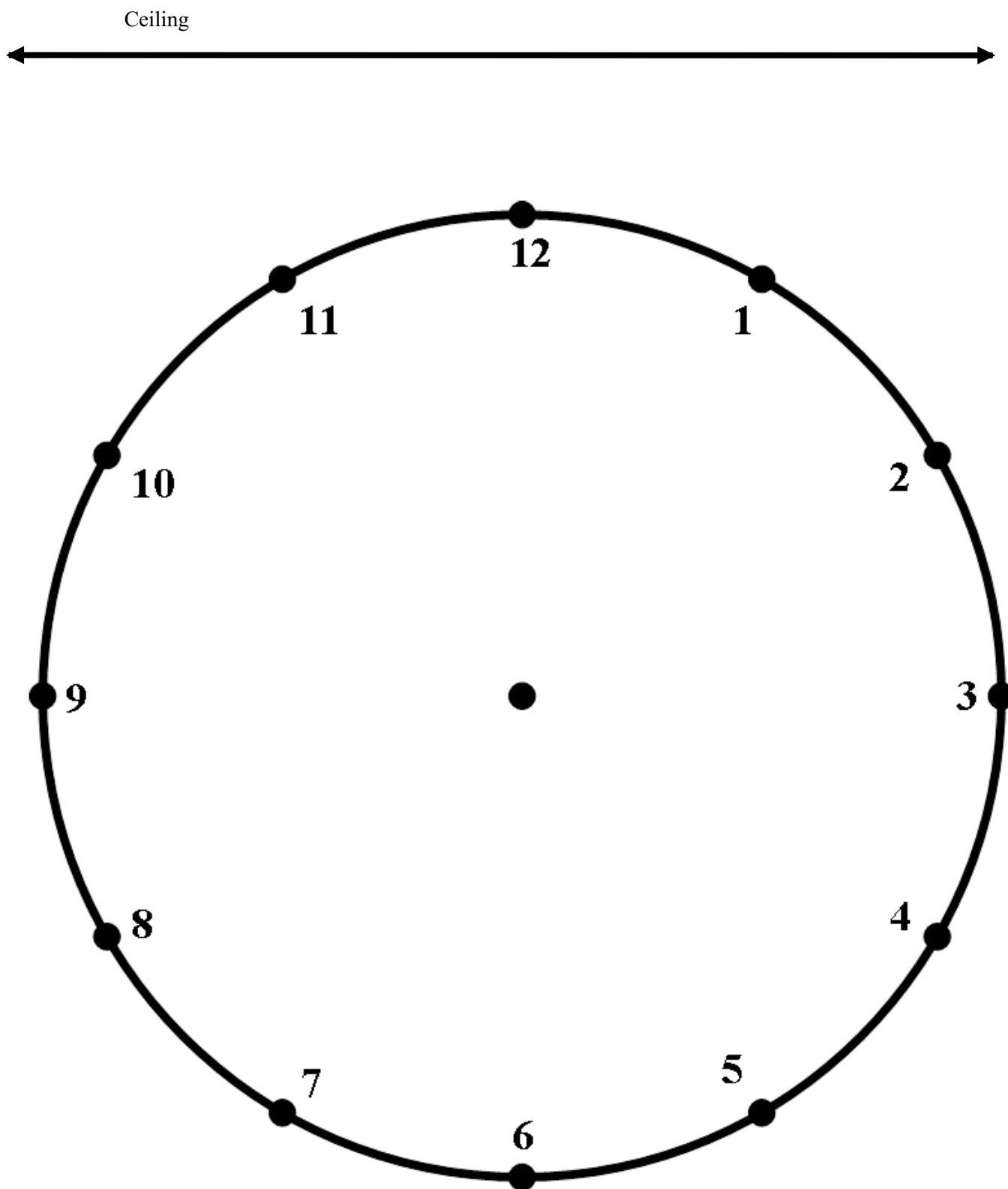

Figuring Out All the Angles

Mathematical Goals

- To extend the concept of angle to a turning motion
- To determine the measures of angles given the amount of rotation
- To develop the concept of radian measure
- To develop the relationship between the radian measure of an angle and the degree measure of an angle.

Georgia Standards of Excellence

MGSE9-12.F.TF.1 Understand radian measure of an angle as the length of the arc on the unit circle subtended by the angle.

Standards for Mathematical Practice

- Make sense of problems and persevere in solving them.
- Reason abstractly and quantitatively.
- Construct viable arguments and critique the reasoning of others.
- Model with mathematics.
- Use appropriate tools strategically.
- Attend to precision.

Introduction

This task focuses on the concept of angle as a turning motion. It also develops the idea of a radian as the unit of measure of an angle.

Materials

- Compass
- Straightedge
- String

PART A: Rotation Angles

An angle is defined as the union of two rays with a common endpoint. The common endpoint is the vertex of the angle and the rays are the sides of the angle. We can extend the way we think about an angle, if we consider an angle as a turning motion. Imagine the two rays are fastened by a pin at the vertex. One ray is kept fixed as a reference (called the **initial side** of the angle) and the other ray (the **terminal side**) is allowed to rotate to form an angle. Angles formed in this way are referred to as **rotation angles**.

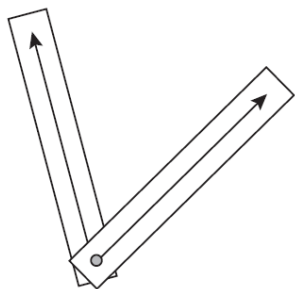

A good way to illustrate this is to cut out two strips from cardstock that are about 1 inch (2.5 cm) by 8 inches (20 cm). Use a ruler to draw a ray down the middle of each strip. Connect the strips of cardboard at the end points of the two rays using a paper brad fastener.

- Suppose a ray is rotated about its endpoint. Give the degree measure of the angle formed if the ray makes:
 - a complete rotation 360°
 - $\frac{5}{6}$ of a rotation 300°
 - 2.5 rotations 900°
- The degree measure of an angle is given. Determine its fractional part of a complete rotation.
 - 180° $\frac{1}{2}$
 - 90° $\frac{1}{4}$
 - 45° $\frac{1}{8}$
 - 270° $\frac{3}{4}$

Angles in the Coordinate Plane: One of the major differences between angles as you have previously experienced them and rotation angles is that rotation angles are usually not placed just anywhere. Rotation angles are frequently placed in the coordinate plane so the vertex of the angle is placed at the origin and the initial side lies on the positive side of the x-axis. We say an angle is in **standard position** when the vertex is at the origin and the initial side lies on the positive side of the x-axis. The ray that forms the **initial side** of the angle is rotated around the origin and the resulting ray called the **terminal side** of the angle.

In both Figure A and Figure B the angle shown is in standard position. Both angles have been created by rotating the ray that forms the initial side 45° about the origin. The angles are different in that the initial ray was rotated counterclockwise in Figure A and rotated clockwise in Figure B. To indicate the direction of rotation, an angle is **positive** when the location of the terminal side results

from a counterclockwise rotation. An angle is **negative** when the location of the terminal side results from a clockwise rotation. Thus, the angle in Figure A is 45° whereas the angle in Figure B is -45°

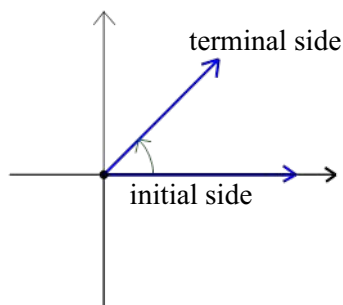

Figure A

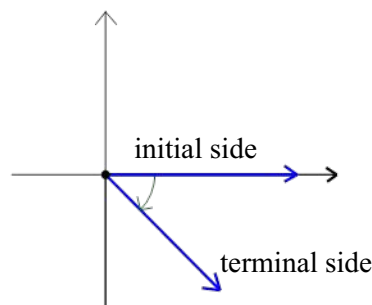
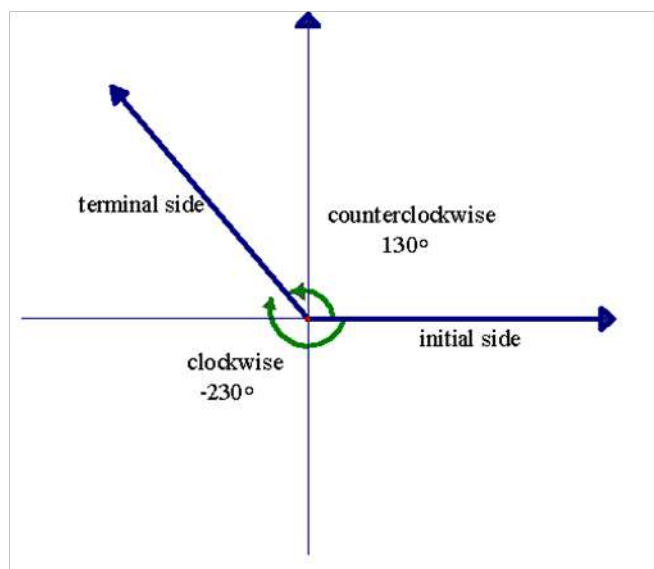

Figure B

If an angle is in standard position and its terminal side falls in the second quadrant, we refer to the angle as a “second quadrant angle.” Similarly, a first quadrant angle, a third quadrant angle, and a fourth quadrant angle have a terminal side that lies in the first quadrant, the third quadrant, and the fourth quadrant, respectively. The angle in Figure A above is a 1st quadrant angle; the angle in figure B is a 4th quadrant angle. An angle of 400° is a first quadrant angle; an angle of -200° is a 2nd quadrant angle.

An angle in standard position with its terminal side lying on either the x-axis or y-axis is called a **quadrantal angle**. A 180° angle and a -90° angle are two examples of quadrantal angles.



Coterminal angles are in standard position and share the same terminal side. The 130° angle and the -230° angle in Figure C are **coterminal** angles. (Remember that the prefix “co” means “together” as in “cooperate” means “to operate or work together” and “cohabitate” means “to live together.” Knowing the meaning of “co” hopefully makes the meaning of “coterminal” more meaningful.)

Angles are also coterminal when they share terminal sides as the result of complete rotations. For example, a 20° angle and a 380° degree angle in standard position are coterminal.

3. Use a protractor to measure each of the angles below. You will need to decide if the measure is positive or negative.

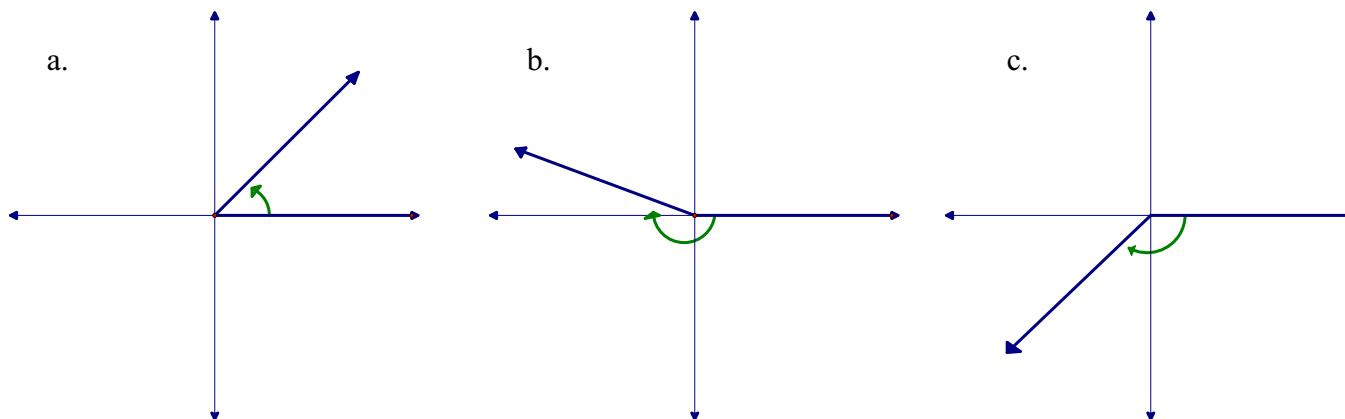

Determine three coterminal angles for each of the angles above.

4. Give an example of a 2nd quadrant angle that has a measure greater than 360°. *Any angle between 450 and 540 degrees. And there are infinitely many more possibilities!*
5. A 180° angle and a –90° angle were given as examples of quadrantal angles. Give the measure of another quadrantal angle. Then determine both a positive angle and a negative angle that are coterminal with the angle you gave.

PART B: What is a Radian?

So far we have been measuring angles in degrees. An angle of one degree is formed by a $\frac{1}{360}$ rotation. Why?

In trigonometry, however, it is more convenient to use a different unit rather than a degree to measure an angle. This unit is called a radian and in this task we will investigate the concept of a radian.

You will need a compass, straightedge, and string to complete this task.

1. On a separate sheet of blank paper, use a compass to draw a circle of any size. Make sure the center of the circle is clearly marked. *Encourage students to draw radii of different lengths, even within the group, so they can compare later.*

- Label the center C . Use a straightedge to draw a radius CA . Label point A .
- Carefully cut a piece of string so it is the length of the radius.
- Beginning at point A , wrap the cut string around the edge of the circle. Mark the point where the string ends on the circle and label this point B .
- Angle ACB is a central angle of the circle. (Recall the definition of central angle from Analytic Geometry.) The central angle ACB intercepts or cuts off an arc with length equal to the radius of the circle. We say that angle ACB has a measure of **1 radian**.
- Compare the measure of your angle ACB to that of others in your group. You can easily do this by superimposing your circle on top of the circle of another in your group. What do you observe? Are all the circles in your group congruent? What about the central angles ACB for all the members of your group—are they congruent?

Students should realize the angle measures of all angles ACB are equal even though the circles may have different radii.

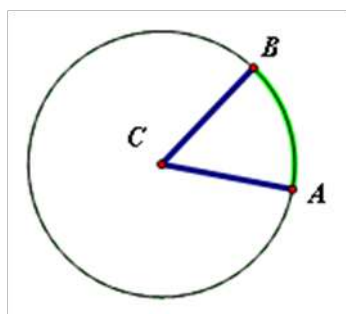

To summarize:

- If a central angle in a circle intercepts an arc equal to the length of the radius of the circle, the measure of the angle is **1 radian**.
 - Angle ACB in the figure on the left is a central angle of the circle. Minor arc AB (shown in green) has length equal to the radius of the circle; thus, angle ACB has measure of 1 radian.
2. Move the string that is the length of your radius to point B and wrap it to the circle again. Continue this process until you have gone completely around the circle. How many radius lengths did it take to complete the distance around the circle? What geometric concept does this reflect?

Answers will vary. Encourage students to approximate as accurately as possible how the length of arc MA compares to the radius. Students will hopefully see arc MA is approximately $\frac{1}{4}$ the length of the radius so it takes approximately $6\frac{1}{4}$ radius lengths to complete the distance around the circle.

The concept illustrated in this process is circumference. $C = 2\pi r$ which is approximately $2(3.14)(r)$ or $6.28r$.

3. In the drawing on the right, the length of each minor arc AB, BD, DP, PH, HK, and KM is the length of the radius.
- a. Central angle PCB has measure of 2 radians. Why?

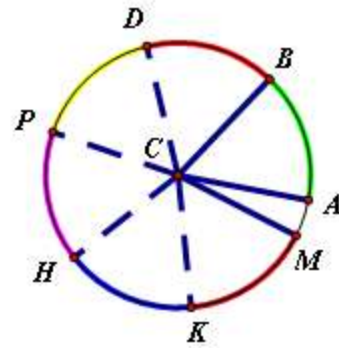

Angle PCB intercepts an arc that is the length of 2 radii so its measure is 2 radians.

- b. Name an angle that has a measure of 4 radians.

$\angle ACH$, $\angle BCK$, and $\angle DCM$ measure 4 radians

- c. Draw a central angle with measure 3.5 radians.

One possibility: Locate a point N halfway between points P and H on the circle. Angle ACN has measure 3.5 radians.

- d. If an angle is formed by a complete rotation of a ray about its endpoint, approximately what is its radian measure? Explain.

It is about $6\frac{1}{4}$ radians because the intercepted arc has a length that is approximately $6\frac{1}{4}$ radii.

4. Let's see if we can look for a more general relationship between the radian measure of a central angle and the length of the arc it intercepts. The circle with radius DF is shown. Thoughtfully consider these questions:

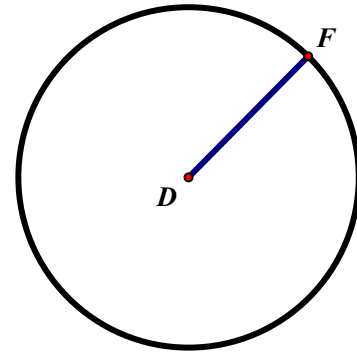

- a. Suppose radius $DF = 4$ inches. Point G is located on the circle.
- If angle FDG is 1 radian, how long is arc FG? *4 inches*
 - If angle FDG is 3 radians, how long is arc FG? *12 inches*
 - If angle FDG is 4.5 radians, how long is arc FG? *18 inches*

Georgia Department of Education
Georgia Standards of Excellence Framework
GSE Pre-Calculus • Unit 1

- b. Suppose DF is 3 inches long and point G is located on the circle.
- If arc FG is 6 inches long, what is the radian measure of angle FDG? *2 radians*
 - If arc FG is 15 inches long, what is the radian measure of angle FDG? *5 radians*
 - If arc FG is 20 inches long, what is the radian measure of angle FDG? *$6\frac{2}{3}$ radians*

- c. Let's generalize: Suppose r is the length of DF. Point G is located on the circle.
- If s is the length of arc FG, what expression represents the radian measure of central angle FDG in terms of r and s ?

Encourage students to look for patterns in parts (a) and (b) that will help them see the radian measure is found by seeing how many radius lengths are contained in the intercepted arc; for each radius length in the arc, the angle measure increases by 1 radian.

- Let θ represent the radian measure of central angle FDG. Write an equation to relate θ , r , and s .

$\theta = \frac{s}{r}$ where θ is the radian measure of the central angle, r is the radius of the circle, and s is the length of the arc intercepted by the angle.

- d. Now consider a central angle in a circle formed when the radius makes a complete rotation about the center of the circle. Let r be the radius of the circle. What is the arc the central angle intercepts?

The arc is the circle; i.e., the circumference of the circle.

How long is this arc? *The arc is $2\pi r$ in length.*

Use what you found out in part (c), to figure out the exact radian measure of this angle.

Explain your thinking. *$\theta = \frac{s}{r}$ so $\theta = \frac{2\pi r}{r} = 2\pi$ radians*

- e. The angle in part (d) was formed by a complete rotation. Therefore, its degree measure is *360°*. In part (d) you found its radian measure is *2π radians*. Therefore, we can conclude *2π* radians = *360°* degrees.
Encourage students to see this is equivalent to π radians = 180°.

Does this conclusion match your approximation in part (3d)?

In part (3d) we approximated $6\frac{1}{4}$ radians which is a good approximation to 2π radians.

Georgia Department of Education
 Georgia Standards of Excellence Framework
 GSE Pre-Calculus • Unit 1

5. From question 4 you should have concluded that an angle formed by a complete rotation measures 2π radians or 360° . This means that π radians is equivalent to 180° . Why? This means that half of a rotation is π radians. Do you see this?

In the following problems, think about fractional parts of a rotation to help you determine the angle measures. For example, a

- a. Since 90° is $\frac{1}{4}$ of a complete rotation, how many radians does 90° equal?

90° is $\frac{1}{4}$ of a complete rotation; therefore, 90° is $\frac{1}{4}$ of 2π radians which is $\frac{2\pi}{4} = \frac{\pi}{2}$ radians.

- b. Since 270° is three-quarters of a rotation, how many radians does 270° equal?

$\frac{3}{4}(2\pi) = \frac{3\pi}{2}$ radians

- c. 45° is _____ of a complete rotation, so it is _____ radians.

45° is $\frac{1}{8}$ of a complete rotation, so it is $\frac{1}{8}(2\pi)$ or $\frac{\pi}{4}$ radians.

- d. 120° is _____ of a complete rotation so it is _____ radians.

120° is $\frac{1}{3}$ of a complete rotation so it is $\frac{2\pi}{3}$ radians.

6. Use what you know about the relationship between degrees and radians to make the following conversions.

Degrees to Radians

- a. $32^\circ =$ _____ $\frac{8\pi}{45}$
 b. $200^\circ =$ _____ $\frac{10\pi}{9}$
 c. $-40^\circ =$ _____ $\frac{-2\pi}{9}$

Radians to Degrees

- d. $\frac{7\pi}{8} =$ _____ 157.5°
 e. $\frac{3\pi}{4} =$ _____ 135°
 f. $2 =$ _____ 114.59°

NOTE: *If an angle measure is given as a number such as 2 or $\frac{\pi}{6}$ with no units given, the unit is understood to be radians. This is because when you divide the length of the intercepted arc by the radius of the circle, the linear units divide out. The number you get from the division tells you how many radius lengths is the intercepted arc; for each radius length, the angle measure is 1 radian.*

Figuring Out All the Angles

PART A: Rotation Angles

An angle is defined as the union of two rays with a common endpoint. The common endpoint is the vertex of the angle and the rays are the sides of the angle. We can extend the way we think about an angle, if we consider an angle as a turning motion. Imagine the two rays are fastened by a pin at the vertex. One ray is kept fixed as a reference (called the *initial side* of the angle) and the other ray (the

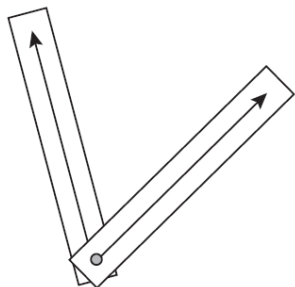

terminal side) is allowed to rotate to form an angle. Angles formed in this way are referred to as *rotation angles*.

A good way to illustrate this is to cut out two strips from cardstock that are about 1 inch (2.5 cm) by 8 inches (20 cm). Use a ruler to draw a ray down the middle of each strip. Connect the strips of cardboard at the end points of the two rays using a paper brad fastener.

- Suppose a ray is rotated about its endpoint. Give the degree measure of the angle formed if the ray makes:
 - a complete rotation
 - $\frac{5}{6}$ of a rotation
 - 2.5 rotations
- The degree measure of an angle is given. Determine its fractional part of a complete rotation.
 - 180°
 - 90°
 - 45°
 - 270°

Angles in the Coordinate Plane: One of the major differences between angles as you have previously experienced them and rotation angles is that rotation angles are usually not placed just anywhere. Rotation angles are frequently placed in the coordinate plane so the vertex of the angle is placed at the origin and the initial side lies on the positive side of the x-axis. We say an angle is in *standard position* when the vertex is at the origin and the initial side lies on the positive side of the x-axis. The ray that forms the *initial side* of the angle is rotated around the origin and the resulting ray called the *terminal side* of the angle.

In both Figure A and Figure B the angle shown is in standard position. Both angles have been created by rotating the ray that forms the initial side 45° about the origin. The angles are different in that the initial ray was rotated counterclockwise in Figure A and rotated clockwise in Figure B. To indicate the direction of rotation, an angle is **positive** when the location of the terminal side results from a counterclockwise rotation. An angle is **negative** when the location of the terminal side results from a clockwise rotation. Thus, the angle in Figure A is 45° whereas the angle in Figure B is -45°

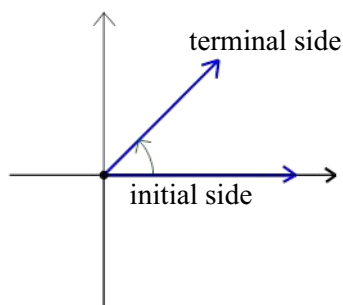

Figure A

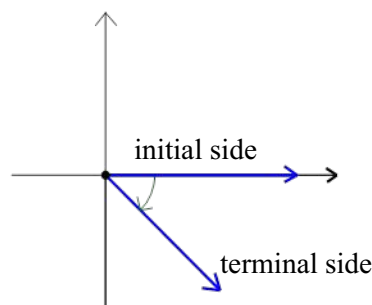
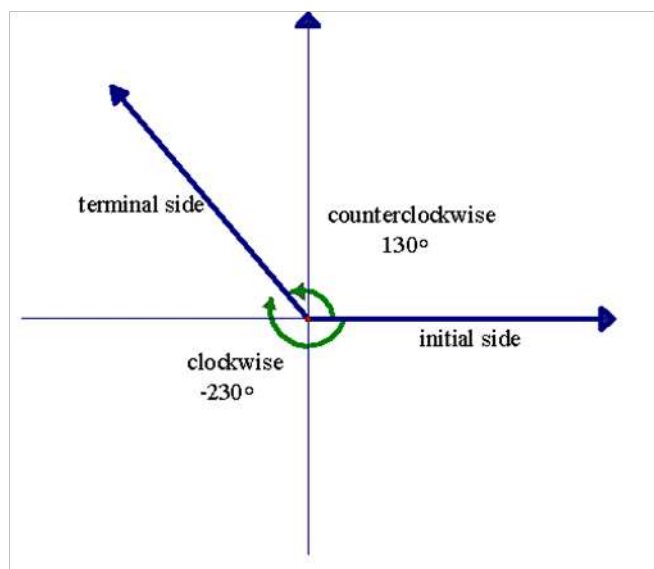

Figure B

If an angle is in standard position and its terminal side falls in the second quadrant, we refer to the angle as a “second quadrant angle.” Similarly, a first quadrant angle, a third quadrant angle, and a fourth quadrant angle have a terminal side that lies in the first quadrant, the third quadrant, and the fourth quadrant, respectively. The angle in Figure A above is a 1st quadrant angle; the angle in figure B is a 4th quadrant angle. An angle of 400° is a first quadrant angle; an angle of -200° is a 2nd quadrant angle.

An angle in standard position with its terminal side lying on either the x-axis or y-axis is called a **quadrantal angle**. A 180° angle and a -90° angle are two examples of quadrantal angles.

Coterminal angles are in standard position and share the same terminal side. The 130° angle and the -230° angle in Figure C are **coterminal** angles. (Remember that the prefix “co” means “together” as in “cooperate” means “to operate or work together” and “cohabitate”



means “to live together.” Knowing the meaning of “co” hopefully makes the meaning of “coterminal” more meaningful.)

Angles are also coterminal when they share terminal sides as the result of complete rotations. For example, a 20° angle and a 380° degree angle in standard position are coterminal.

3. Use a protractor to measure each of the angles below. You will need to decide if the measure is positive or negative.

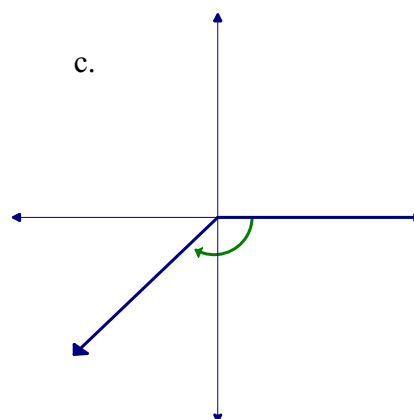
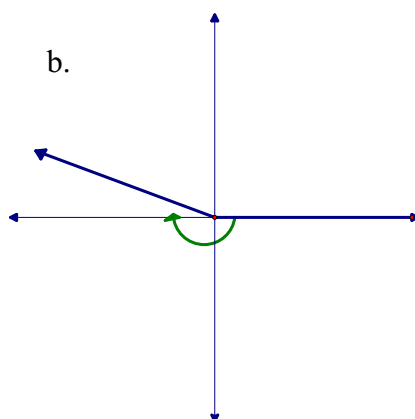
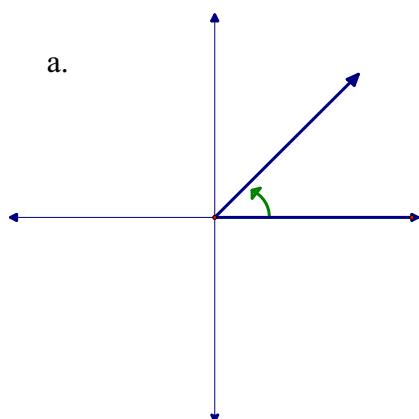

Determine three coterminal angles for each of the angles above.

4. Give an example of a 2nd quadrant angle that has a measure greater than 360° .

5. A 180° angle and a -90° angle were given as examples of quadrantal angles. Give the measure of another quadrantal angle. Then determine both a positive angle and a negative angle that are coterminal with the angle you gave.

PART B: What is a Radian?

So far we have been measuring angles in degrees. An angle of one degree is formed by a $\frac{1}{360}$ rotation. Why?

In trigonometry, however, it is more convenient to use a different unit rather than a degree to measure an angle. This unit is called a radian and in this task we will investigate the concept of a radian.

You will need a compass, straightedge, and string to complete this task.

1. On a separate sheet of blank paper, use a compass to draw a circle of any size. Make sure the center of the circle is clearly marked.
2. Label the center C. Use a straightedge to draw a radius CA. Label point A.
 - Carefully cut a piece of string so it is the length of the radius.
 - Beginning at point A, wrap the cut string around the edge of the circle. Mark the point where the string ends on the circle and label this point B.
 - Angle ACB is a central angle of the circle. (Recall the definition of central angle from Analytic Geometry.) The central angle ACB intercepts or cuts off an arc with length equal to the radius of the circle. We say that angle ACB has a measure of **1 radian**.
 - Compare the measure of your angle ACB to that of others in your group. You can easily do this by superimposing your circle on top of the circle of another in your group. What do you observe? Are all the circles in your group congruent? What about the central angles ACB for all the members of your group—are they congruent?

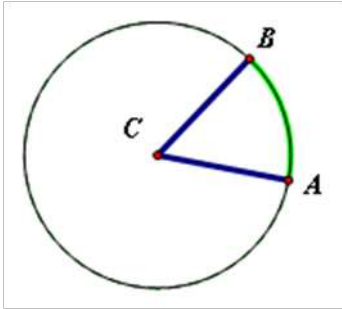

To summarize:

- If a central angle in a circle intercepts an arc equal to the length of the radius of the circle, the measure of the angle is **1 radian**.
- Angle ACB in the figure on the left is a central angle of the circle. Minor arc AB (shown in green) has length equal to the radius of the circle; thus, angle ACB has measure of 1 radian.

3. Move the string that is the length of your radius to point B and wrap it to the circle again. Continue this process until you have gone completely around the circle. How many radius lengths did it take to complete the distance around the circle? What geometric concept does this reflect?

4. In the drawing on the right, the length of each minor arc AB, BD, DP, PH, HK, and KM is the length of the radius.
- a. Central angle PCB has measure of 2 radians. Why?
 - b. Name an angle that has a measure of 4 radians.
 - c. Draw a central angle with measure 3.5 radians.
 - d. If an angle is formed by a complete rotation of a ray about its endpoint, approximately what is its radian measure? Explain.

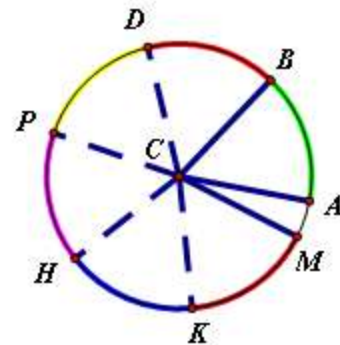

5. Let's see if we can look for a more general relationship between the radian measure of a central angle and the length of the arc it intercepts. The circle with radius DF is shown. Thoughtfully consider these questions:

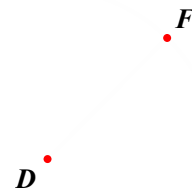

Georgia Department of Education
Georgia Standards of Excellence Framework
GSE Pre-Calculus • Unit 1

- a. Suppose radius $DF = 4$ inches. Point G is located on the circle.
- If angle FDG is 1 radian, how long is arc FG ?
 - If angle FDG is 3 radians, how long is arc FG ?
 - If angle FDG is 4.5 radians, how long is arc FG ?
- b. Suppose DF is 3 inches long and point G is located on the circle.
- If arc FG is 6 inches long, what is the radian measure of angle FDG ?
 - If arc FG is 15 inches long, what is the radian measure of angle FDG ?
 - If arc FG is 20 inches long, what is the radian measure of angle FDG ?
- c. Let's generalize: Suppose r is the length of DF . Point G is located on the circle.
- If s is the length of arc FG , what expression represents the radian measure of central angle FDG in terms of r and s ?
 - Let θ represent the radian measure of central angle FDG . Write an equation to relate θ , r , and s .
- d. Now consider a central angle in a circle formed when the radius makes a complete rotation about the center of the circle. Let r be the radius of the circle. What is the arc the central angle intercepts?

How long is this arc?

Use what you found out in part (c), to figure out the exact radian measure of this angle. Explain your thinking.

Georgia Department of Education
Georgia Standards of Excellence Framework
GSE Pre-Calculus • Unit 1

- e. The angle in part (d) was formed by a complete rotation. Therefore, its degree measure is _____. In part (d) you found its radian measure is _____. Therefore, we can conclude _____ radians = _____ degrees.

Does this conclusion match your approximation in part (3d)?

6. From question 4 you should have concluded that an angle formed by a complete rotation measures 2π radians or 360° . This means that π radians is equivalent to 180° . Why? This means that half of a rotation is π radians. Do you see this?

In the following problems, think about fractional parts of a rotation to help you determine the angle measures. For example, a

- a. Since 90° is $\frac{1}{4}$ of a complete rotation, how many radians does 90° equal?
- b. Since 270° is three-quarters of a rotation, how many radians does 270° equal?
- c. 45° is _____ of a complete rotation, so it is _____ radians.
- d. 120° is _____ of a complete rotation so it is _____ radians.

Georgia Department of Education
Georgia Standards of Excellence Framework
GSE Pre-Calculus • Unit 1

7. Use what you know about the relationship between degrees and radians to make the following conversions.

Degrees to Radians

a. $32^\circ =$ _____

b. $200^\circ =$ _____

c. $-40^\circ =$ _____

Radians to Degrees

d. $\frac{7\pi}{8} =$ _____

e. $\frac{3\pi}{4} =$ _____

f. $2 =$ _____

Real Numbers and the Unit Circle

Mathematical Goals

- Connect a real number to a point on the unit circle
- To interpret information from the unit circle.
- To determine the exact points on the unit circle for certain special real numbers.

Georgia Standards of Excellence

MGSE9-12.F.TF.2 Explain how the unit circle in the coordinate plane enables the extension of trigonometric functions to all real numbers, interpreted as radian measures of angles traversed counterclockwise around the unit circle.

Standards for Mathematical Practice

- Make sense of problems and persevere in solving them.
- Reason abstractly and quantitatively.
- Construct viable arguments and critique the reasoning of others.
- Model with mathematics.
- Use appropriate tools strategically.
- Attend to precision.
- Look for and make use of structure.
- Look for and express regularity in repeated reasoning.

Introduction

In this task we will begin to pull the ideas from the preceding tasks together.

Materials

Calculator

PART A:

The radian measure of an angle was defined in terms of the radius of a circle. The circle in trigonometry that is of utmost importance is the ***unit circle***. The unit circle is the circle with center at the origin and a radius of 1 unit. Shown below is the unit circle.

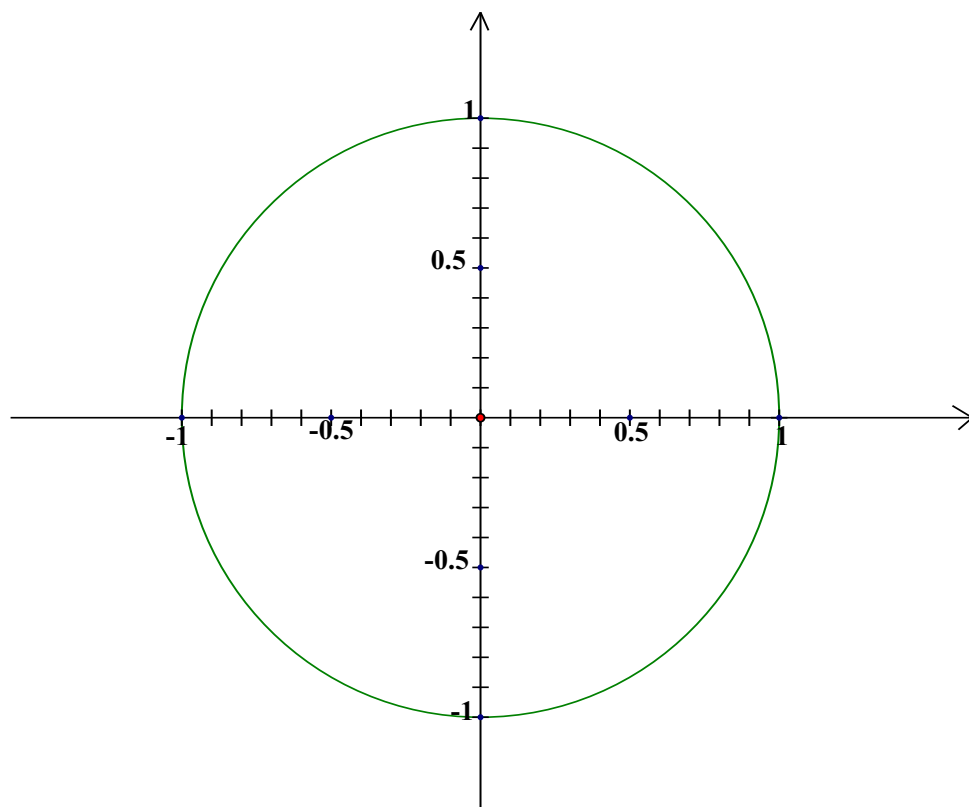

1. The axes have been calibrated into tenths of a unit. Use a straightedge or the edge of a piece of paper to help you approximate the following.
 - a. Approximate the y-coordinate of the points on the unit circle that have an x-coordinate of 0.4.

y is approximately 0.9 or -0.9

- b. Approximate the x-coordinate of the points on the unit circle that have a y-coordinate of -0.7.

x is approximately 0.71 or -0.71

Recall from Analytic Geometry the equation of a circle with center (h, k) and radius r is $(x - h)^2 + (y - k)^2 = r^2$. Therefore, the equation of the unit circle is $x^2 + y^2 = 1$. Why?

2. Show that the point $\left(\frac{1}{4}, \frac{\sqrt{15}}{4}\right)$ is on the unit circle. $\left(\frac{1}{4}\right)^2 + \left(\frac{\sqrt{15}}{4}\right)^2 = 1$
3. The point $\left(\frac{\sqrt{5}}{3}, y\right)$ is on the unit circle in quadrant IV. Find its y-coordinate. $-\frac{2}{3}$

Georgia Department of Education
Georgia Standards of Excellence Framework
GSE Pre-Calculus • Unit 1

4. Below is a calibrated unit circle. Beginning at the point $(1, 0)$ and going in a counterclockwise direction, radius lengths have been marked off on the circle.

a. Indicate the angle in standard position that has a measure of 1 radian.

- This angle intercepts an arc on the unit circle. How long is this intercepted arc?

The arc is 1 unit long—the same length as the radius of the circle.

- The initial point of this arc is $(1, 0)$. Approximate the coordinates of the terminal point of this arc. $(0.54, 0.84)$

b. Indicate the angle in standard position that has a measure of -1 radian.

- How long is the arc this angle intercepts on the unit circle? What does the negative value indicate?

The arc is the same length as the radius. Because we traverse the unit circle clockwise to go from its initial point to its terminal point, we say the length of the arc is -1 .

- The initial point of this arc is $(1, 0)$. Approximate the coordinates of the terminal point of the arc.

Its terminal point appears at approximately $(0.54, -0.84)$.

c. Indicate the angle in standard position that has a measure of 4.1 radians.

- How long is the arc this angle intercepts on the unit circle?

The arc is 4.1 units (or 4.1 radius lengths) long.

- Approximate the coordinates of the terminal point of the arc. $(-0.57, -0.82)$

d. Indicate the angle in standard position that has a measure of -2.5 radians.

- How long is its intercepted arc?

2.5 units or 2.5 radius lengths long

- Approximate the coordinates of the terminal point of this arc. $(-0.8, -0.6)$

Georgia Department of Education
Georgia Standards of Excellence Framework
GSE Pre-Calculus • Unit 1

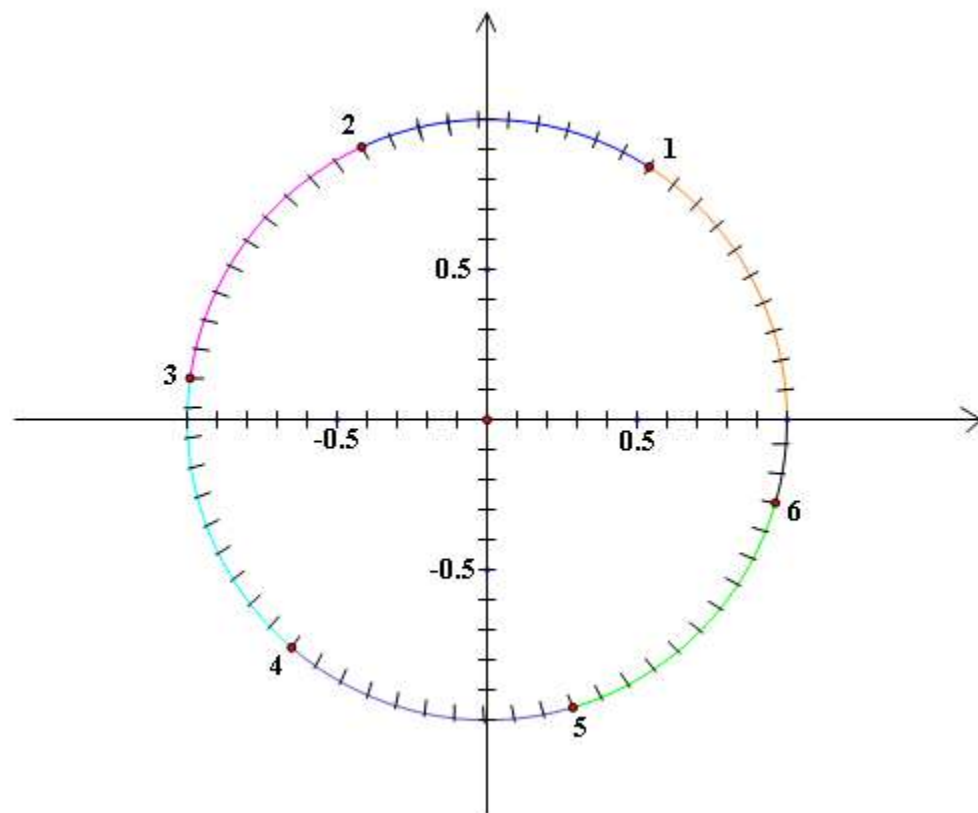

PART B:

One of the primary understandings that must be gained in trigonometry is the relationship between the set of real numbers and the points on the unit circle. This relationship is established through the following statement.

Pairing Real Numbers to Points on the Unit Circle

Suppose t is a real number. There is an angle in standard position that has a measure of t radians. This angle is associated with an arc t on the unit circle that starts at $(1, 0)$. If t is positive, we traverse along this arc $|t|$ units counterclockwise; if t is negative, we traverse along the arc $|t|$ units in a counterclockwise direction. The terminal point $P(x, y)$ of this arc is the point paired with t .

In problem 4b above, we had an angle in standard position with radian measure -1 . So the real number was -1 . The terminal point of the arc associated with the angle was approximately $(0.54, -0.84)$. So using the above statement, -1 is paired with $(0.52, -0.85)$. The following schematic illustrates the connections.

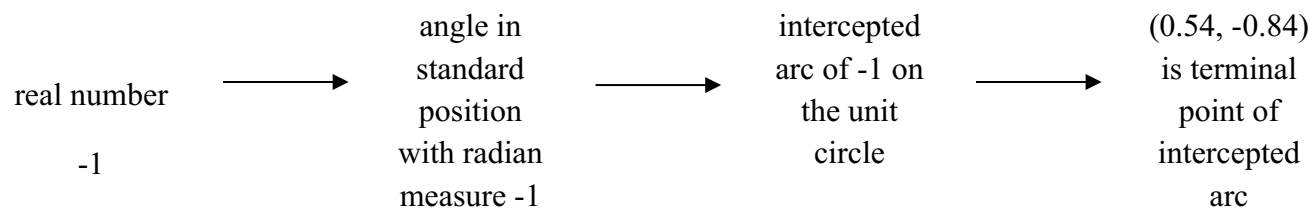

Important things to remember when pairing real numbers to points on the unit circle:

- The real number t represents the radian measure of the angle and the length of the intercepted arc.
 - The angle is in standard position.
 - The angle is measured in radians.
 - We rotate counterclockwise for positive measure and clockwise for a negative measure.
 - The circle is the unit circle.
 - The initial point of the intercepted arc is always $(1, 0)$.
 - We traverse the arc counterclockwise for positive measures and clockwise for negative measures.
1. The circumference of the unit circle is 2π . So we can think about an arc on the unit circle that begins at $(1, 0)$ and goes a distance of 2π in a counterclockwise direction. The terminal point of this arc is also $(1, 0)$ because we make one complete rotation. Thus, real number 2π is paired with $(1, 0)$.

Georgia Department of Education
Georgia Standards of Excellence Framework
GSE Pre-Calculus • Unit 1

2. Think about real number $\frac{\pi}{2}$. We need to think about an arc on the unit circle that begins at $(1, 0)$ and goes a distance of $\frac{\pi}{2}$ in a counterclockwise direction. $\frac{\pi}{2}$ is one-fourth of 2π so its terminal point is $(0, 1)$. Thus, real number $\frac{\pi}{2}$ is paired with $(0, 1)$.
3. Find the exact points associated with the following real numbers. Use the fact that the circumference of the unit circle is 2π rather than merely estimating the points. Think about fractional relationships.
- | | | | |
|---------------------|-----------|----------------------|-----------|
| a. π | $(-1, 0)$ | d. 6π | $(1, 0)$ |
| b. $\frac{3\pi}{2}$ | $(0, -1)$ | e. $\frac{7\pi}{2}$ | $(0, -1)$ |
| c. $-\frac{\pi}{2}$ | $(0, -1)$ | f. $-\frac{3\pi}{2}$ | $(0, 1)$ |

PART C:

In trigonometry there are some special real numbers that appear often so knowing the exact coordinates of their points is extremely helpful. The purpose of the following activities is to provide a meaningful way to determine the points associated with these real numbers. This is a process so be patient!

Step 1—What are the terminal points for angles 0 , $\frac{\pi}{2}$, π , and $\frac{3\pi}{2}$?

The terminal points for angles 0 , $\frac{\pi}{2}$, π , and $\frac{3\pi}{2}$ are shown on the unit circle. The coordinates of these points are easy to determine.

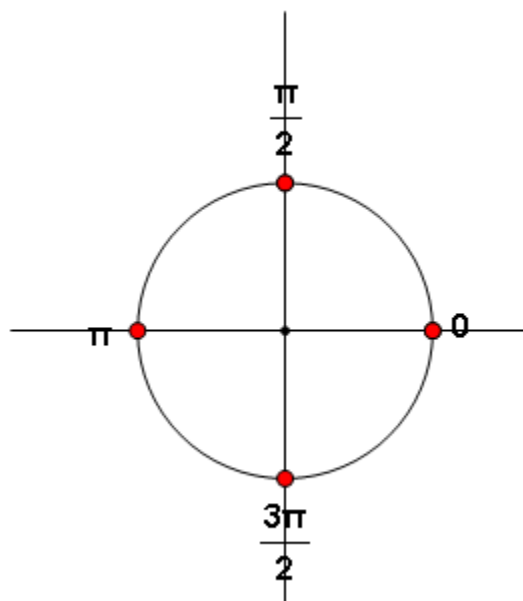

Give other angles that also have each of those points as terminal points. For example, $-\frac{3\pi}{2}$ is also associated with the point $(0, 1)$.

Step 2: What are the terminal points for $\frac{\pi}{4}$, $\frac{3\pi}{4}$, $\frac{5\pi}{4}$, and $\frac{7\pi}{4}$?

The green points on the unit circle divide the circle into 8 congruent arcs. **Explain how the number adjacent to each point is determined.** *The circumference of the circle is 2π so each of the 8 disjoint arcs must be $\frac{\pi}{4}$ units long. When we pair a real number with a terminal point, we are using the*

arc that had an initial point of (1, 0). Since all the numbers given are positive, we are going in a counterclockwise direction.

Now let's determine the coordinates of the point associated with $\frac{\pi}{4}$. The coordinates of this point must satisfy the equation $x^2 + y^2 = 1$. This point is also located on the line $y = x$. Use these two pieces of information to determine the coordinates of this point.

Since $y = x$, the equation becomes $x^2 + x^2 = 1$. So $x = \pm \frac{\sqrt{2}}{2}$. Because the point is in Quadrant I, then x must be positive, and $y = x$. Thus, $\frac{\pi}{4}$ is associated with

$$\left(\frac{\sqrt{2}}{2}, \frac{\sqrt{2}}{2} \right).$$

After you find the coordinates for the terminal point of $\frac{\pi}{4}$, use what you know about the symmetry of the unit circle to determine the coordinates of the points in Quadrants II, III, and IV.

Step 3: What are the terminal points for

angles $\frac{\pi}{6}$, $\frac{\pi}{3}$, $\frac{2\pi}{3}$, $\frac{5\pi}{6}$, $\frac{7\pi}{6}$, $\frac{4\pi}{3}$, $\frac{5\pi}{3}$, and $\frac{11\pi}{6}$?

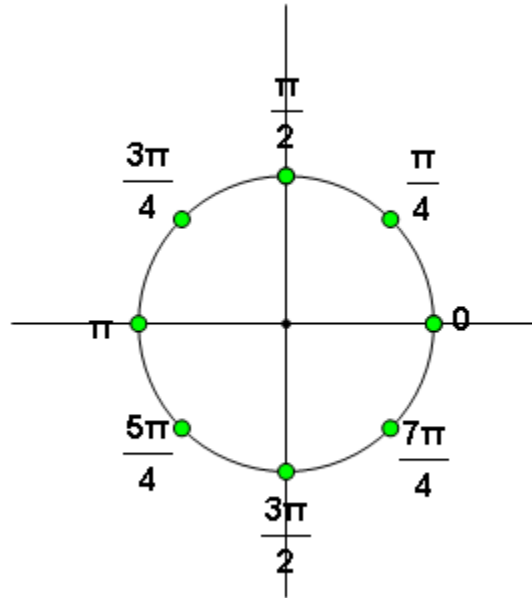

Georgia Department of Education
 Georgia Standards of Excellence Framework
 GSE Pre-Calculus • Unit 1

The blue points on the unit circle divide the circle into 12 congruent arcs. **Explain how the number adjacent to each point is determined.**

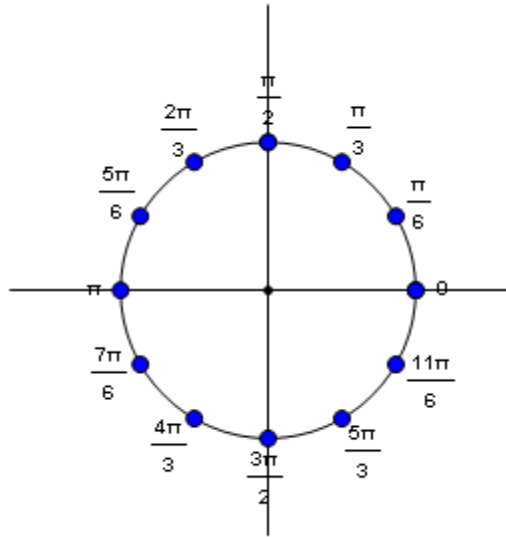

Now we need to determine the coordinates of these points. It will be sufficient for us to determine the coordinates of the points associated with $\frac{\pi}{6}$ and $\frac{\pi}{3}$. The symmetry of the unit circle will be used to determine the other coordinates.

In the figure, point D is the terminal point for arc $\frac{\pi}{6}$. Angle DCB is 30° . Why? A perpendicular segment has been drawn from D to the x-axis to create $\triangle BCD$. This triangle is a 30° - 60° - 90° triangle, one of the special right triangles studied in Analytic Geometry. Explain why $\triangle BCD$ is a 30° - 60° - 90° triangle. Because \overline{CD} is the radius of the unit circle, we know $CD = 1$. Using relationships in a 30° - 60° - 90° triangle, we can conclude $DB = \frac{1}{2}$ and $CB = \frac{\sqrt{3}}{2}$. This means the

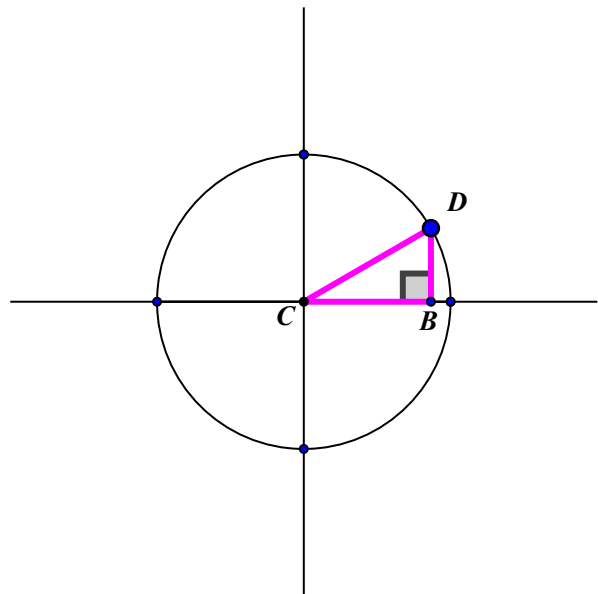

coordinates of point B and point D are $\left(\frac{\sqrt{3}}{2}, 0\right)$

and $\left(\frac{\sqrt{3}}{2}, \frac{1}{2}\right)$, respectively. Thus, we now

Georgia Department of Education
Georgia Standards of Excellence Framework
GSE Pre-Calculus • Unit 1

Georgia Department of Education
Georgia Standards of Excellence Framework
GSE Pre-Calculus • Unit 1

Now let's determine the coordinates of the terminal point of angle $\frac{\pi}{3}$. In the figure,

point H is the terminal point of $\frac{\pi}{3}$. Explain

why $\angle HCF$ is 60° . Segment HF has been drawn perpendicular to the x-axis to create $\triangle HCF$, a 30° - 60° - 90° triangle. Because \overline{CH} is a radius of the unit circle, $CH = 1$. Using relationships in a 30° - 60° - 90° triangle, we can conclude $CF = \frac{1}{2}$ and $FH = \frac{\sqrt{3}}{2}$. This means

the coordinates of points F and H are $\left(\frac{1}{2}, 0\right)$

and $\left(\frac{1}{2}, \frac{\sqrt{3}}{2}\right)$, respectively. Thus, we now

know the terminal point for angle $\frac{\pi}{3}$ is

$$\left(\frac{1}{2}, \frac{\sqrt{3}}{2}\right).$$

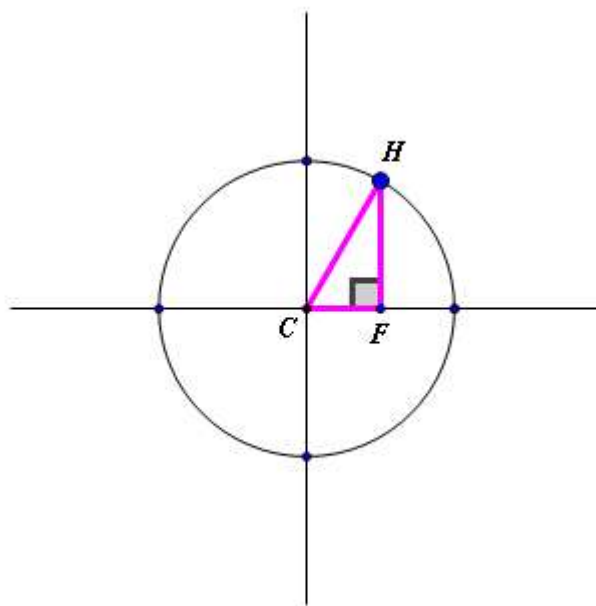

Georgia Department of Education
 Georgia Standards of Excellence Framework
GSE Pre-Calculus • Unit 1

The coordinates for $\frac{\pi}{6}$ and $\frac{\pi}{3}$ are recorded on the unit circle on the right. Use the symmetry of the unit circle to determine the coordinates of all terminal points identified in the figure.

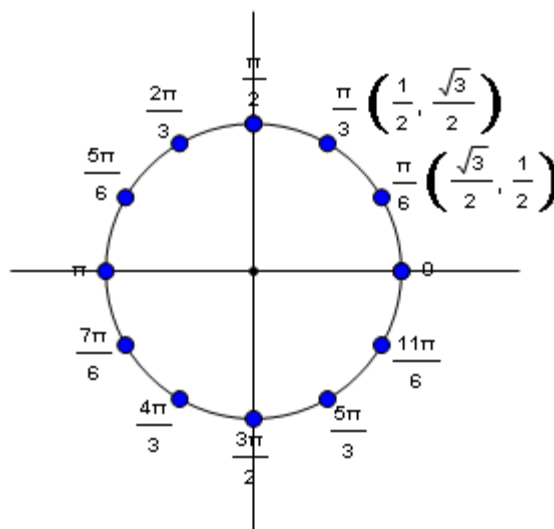

What observations can you make about these points and their angles?

Be sure students make meaningful connections. For example, do they see it makes sense for the x-coordinate associated with $\frac{\pi}{6}$ to be greater than the x-coordinate associated with $\frac{\pi}{3}$ based on where $\frac{\pi}{6}$ terminates? (And for the y-coordinate of $\frac{\pi}{6}$ to be smaller than that of $\frac{\pi}{3}$?)

The unit circle with all the special real numbers between 0 and 2π is shown.

Be sure students understand what the number adjacent to each point represents. Also be sure they have a sense of the fractional relationships between the arc lengths. For example, can they place these numbers on the unit circle based on fractional parts of π ? For example, $\frac{5\pi}{6}$ is $\frac{5}{6}$ of π . Similarly, $\frac{4\pi}{3}$ is $\frac{4}{3}\pi$ or $\left(1\pi + \frac{2}{3}\pi\right)$. Thinking of the arcs in this manner makes the location of them on the unit circle meaningful.

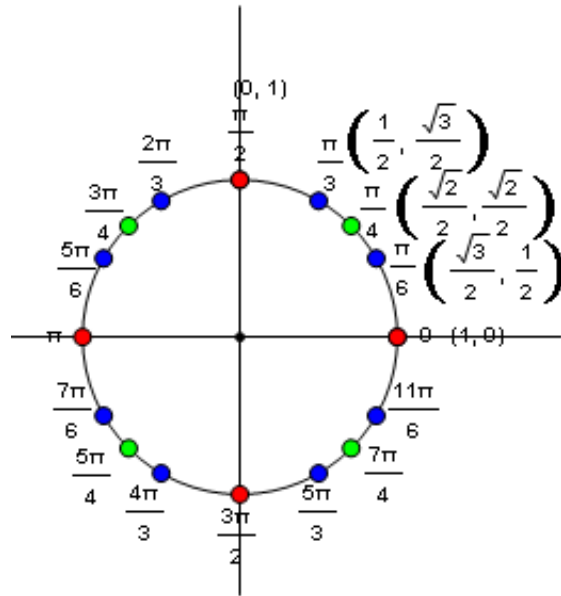

Be sure students can determine the coordinates of the other terminal points. They should not memorize all the information in the unit circle. Instead, encourage them to make sense of the first quadrant information; they can then use fractional concepts, symmetry, etc. to determine the other values as needed. In fact, if you will encourage them to draw the first quadrant as a reference, they can determine all other needed values. See below.

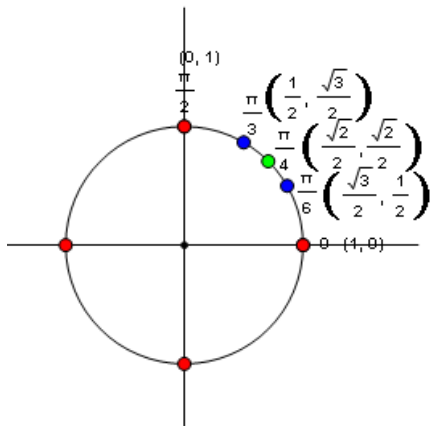

Georgia Department of Education
Georgia Standards of Excellence Framework
GSE Pre-Calculus • Unit 1

Let's determine the terminal point for $\frac{9\pi}{4}$. Since $\frac{9\pi}{4}$ is $\frac{9}{4}\pi$ or $2\frac{1}{4}\pi$, then this is equivalent to traversing the unit circle, beginning at $(1,0)$, in a counterclockwise direction 1 complete rotation (for 2π) and then $\frac{1}{4}\pi$ more. This means the terminal point for $\frac{9\pi}{4}$ is the same as that for $\frac{\pi}{4}$. So $\frac{9\pi}{4}$ has terminal point $\left(\frac{\sqrt{2}}{2}, \frac{\sqrt{2}}{2}\right)$.

To determine the terminal point for $-\frac{4\pi}{3}$, we can think about going in a clockwise direction a distance of $1\frac{2}{3}\pi$. This puts us in Quadrant II at the same point where $\frac{2\pi}{3}$ terminates. The coordinates of this point are $\left(-\frac{1}{2}, \frac{\sqrt{3}}{2}\right)$, and we can use the coordinates of $\frac{\pi}{3}$ to help us see this.

So the terminal point of $-\frac{4\pi}{3}$ is

$$\left(-\frac{1}{2}, \frac{\sqrt{3}}{2}\right).$$

In the above examples the terminal points associated with $\frac{\pi}{4}$ and $\frac{\pi}{3}$ were used to help determine the terminal points of $\frac{9\pi}{4}$ and $-\frac{4\pi}{3}$, respectively. We call $\frac{\pi}{4}$ and $\frac{\pi}{3}$ **reference numbers**. To find the terminal point for any real number, we need only to know the terminal point of the reference number.

Reference Number

Let t be a real number. The reference number t' associated with t is the shortest distance along the unit circle between the terminal point determined by t and the x-axis. The reference number is always positive.

To determine the terminal point associated with real number t , determine the terminal point for its reference number. Affix the correct signs to the x-coordinate and y-coordinate based on the quadrant in which t terminates.

Georgia Department of Education
Georgia Standards of Excellence Framework
GSE Pre-Calculus • Unit 1

EXAMPLE: $\frac{17\pi}{6}$ is $2\frac{5}{6}\pi$ so it terminates in Quadrant II. Its reference number is $\frac{\pi}{6}$. Thus, the

terminal point for $\frac{17\pi}{6}$ is $\left(-\frac{\sqrt{3}}{2}, \frac{1}{2}\right)$.

Determine the terminal point for each real number.

a. $\frac{8\pi}{3}$ $\left(-\frac{1}{2}, \frac{\sqrt{3}}{2}\right)$

e. $-\frac{2\pi}{3}$ $\left(-\frac{1}{2}, -\frac{\sqrt{3}}{2}\right)$

b. $-\frac{11\pi}{6}$ $\left(\frac{\sqrt{3}}{2}, \frac{1}{2}\right)$

f. 5π $(-1, 0)$

c. $\frac{7\pi}{6}$ $\left(-\frac{\sqrt{3}}{2}, -\frac{1}{2}\right)$

g. $\frac{3\pi}{4}$ $\left(-\frac{\sqrt{2}}{2}, \frac{\sqrt{2}}{2}\right)$

d. $\frac{-7\pi}{4}$ $\left(\frac{\sqrt{2}}{2}, \frac{\sqrt{2}}{2}\right)$

h. $\frac{10\pi}{3}$ $\left(-\frac{1}{2}, -\frac{\sqrt{3}}{2}\right)$

Real Numbers and the Unit Circle

PART A:

The radian measure of an angle was defined in terms of the radius of a circle. The circle in trigonometry that is of utmost importance is the *unit circle*. The unit circle is the circle with center at the origin and a radius of 1 unit. Shown below is the unit circle.

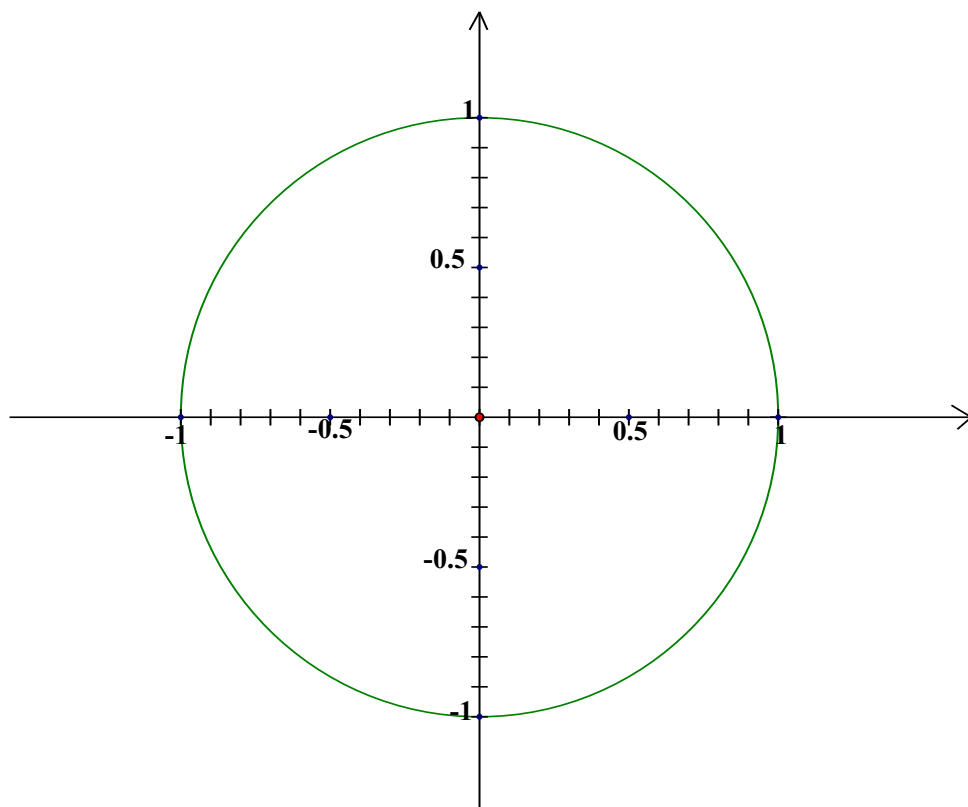

1. The axes have been calibrated into tenths of a unit. Use a straightedge or the edge of a piece of paper to help you approximate the following.
 - Approximate the y-coordinate of the points on the unit circle that have an x-coordinate of 0.4.
 - Approximate the x-coordinate of the points on the unit circle that have a y-coordinate of -0.7.

Recall from Analytic Geometry the equation of a circle with center (h, k) and radius r is $(x - h)^2 + (y - k)^2 = r^2$. Therefore, the equation of the unit circle is $x^2 + y^2 = 1$. Why?

2. Show that the point $\left(\frac{1}{4}, \frac{\sqrt{15}}{4}\right)$ is on the unit circle.

Georgia Department of Education
Georgia Standards of Excellence Framework
GSE Pre-Calculus • Unit 1

3. The point $\left(\frac{\sqrt{5}}{3}, y\right)$ is on the unit circle in quadrant IV. Find its y-coordinate.
4. Below is a calibrated unit circle. Beginning at the point $(1, 0)$ and going in a counterclockwise direction, radius lengths have been marked off on the circle.
- a. Indicate the angle in standard position that has a measure of 1 radian.
- This angle intercepts an arc on the unit circle. How long is this intercepted arc?
 - The initial point of this arc is $(1, 0)$. Approximate the coordinates of the terminal point of this arc.
- b. Indicate the angle in standard position that has a measure of -1 radian.
- How long is the arc this angle intercepts on the unit circle? What does the negative value indicate?
 - The initial point of this arc is $(1, 0)$. Approximate the coordinates of the terminal point of the arc.
 - Indicate the angle in standard position that has a measure of 4.1 radians.
 - How long is the arc this angle intercepts on the unit circle?
 - Approximate the coordinates of the terminal point of the arc.
 - Indicate the angle in standard position that has a measure of -2.5 radians.
 - How long is its intercepted arc?
 - Approximate the coordinates of the terminal point of this arc.

Georgia Department of Education
Georgia Standards of Excellence Framework
GSE Pre-Calculus • Unit 1

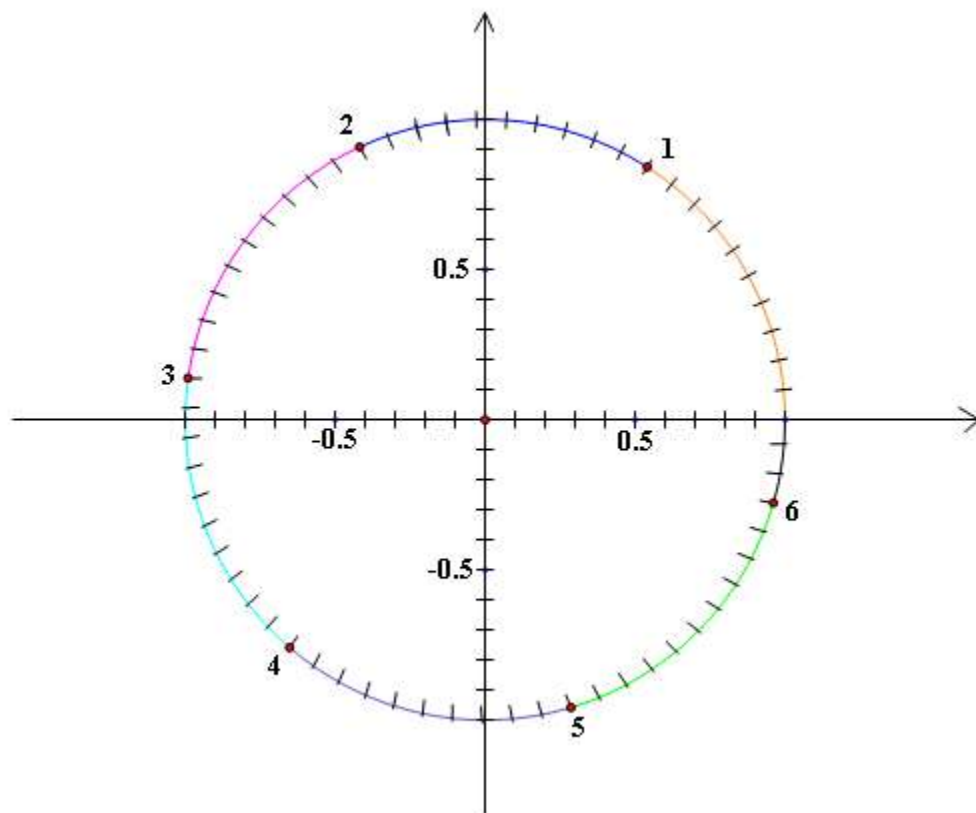

PART B:

One of the primary understandings that must be gained in trigonometry is the relationship between the set of real numbers and the points on the unit circle. This relationship is established through the following statement.

Pairing Real Numbers to Points on the Unit Circle

Suppose t is a real number. There is an angle in standard position that has a measure of t radians. This angle is associated with an arc t on the unit circle that starts at $(1, 0)$. If t is positive, we traverse along this arc $|t|$ units counterclockwise; if t is negative, we traverse along the arc $|t|$ units in a counterclockwise direction. The terminal point $P(x, y)$ of this arc is the point paired with t .

In problem 4b above, we had an angle in standard position with radian measure -1 . So the real number was -1 . The terminal point of the arc associated with the angle was approximately $(0.54, -0.84)$. So using the above statement, -1 is paired with $(0.52, -0.85)$. The following schematic illustrates the connections.

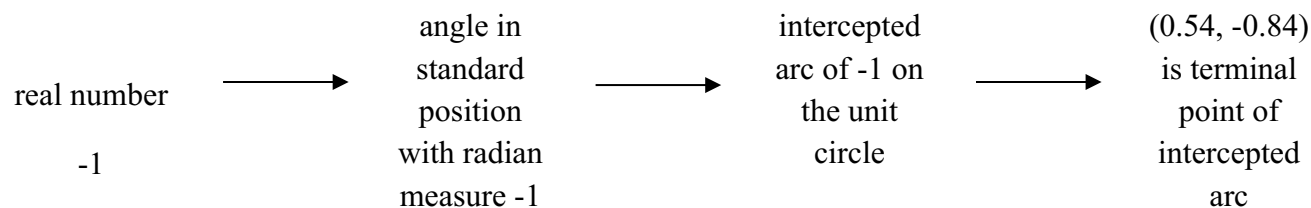

Important things to remember when pairing real numbers to points on the unit circle:

- The real number t represents the radian measure of the angle and the length of the intercepted arc.
 - The angle is in standard position.
 - The angle is measured in radians.
 - We rotate counterclockwise for positive measure and clockwise for a negative measure.
 - The circle is the unit circle.
 - The initial point of the intercepted arc is always $(1, 0)$.
 - We traverse the arc counterclockwise for positive measures and clockwise for negative measures.
1. The circumference of the unit circle is 2π . So we can think about an arc on the unit circle that begins at $(1, 0)$ and goes a distance of 2π in a counterclockwise direction. The terminal point of this arc is also $(1, 0)$ because we make one complete rotation. Thus, real number 2π is paired with $(1, 0)$.

Georgia Department of Education
Georgia Standards of Excellence Framework
GSE Pre-Calculus • Unit 1

2. Think about real number $\frac{\pi}{2}$. We need to think about an arc on the unit circle that begins at $(1, 0)$ and goes a distance of $\frac{\pi}{2}$ in a counterclockwise direction. $\frac{\pi}{2}$ is one-fourth of 2π so its terminal point is $(0, 1)$. Thus, real number $\frac{\pi}{2}$ is paired with $(0, 1)$.
3. Find the exact points associated with the following real numbers. Use the fact that the circumference of the unit circle is 2π rather than merely estimating the points. Think about fractional relationships.
- | | |
|---------------------|----------------------|
| a. π | d. 6π |
| b. $\frac{3\pi}{2}$ | e. $\frac{7\pi}{2}$ |
| c. $-\frac{\pi}{2}$ | f. $-\frac{3\pi}{2}$ |

PART C:

In trigonometry there are some special real numbers that appear often so knowing the exact coordinates of their points is extremely helpful. The purpose of the following activities is to provide a meaningful way to determine the points associated with these real numbers. This is a process so be patient!

Step 1—What are the terminal points for angles 0 , $\frac{\pi}{2}$, π , and $\frac{3\pi}{2}$?

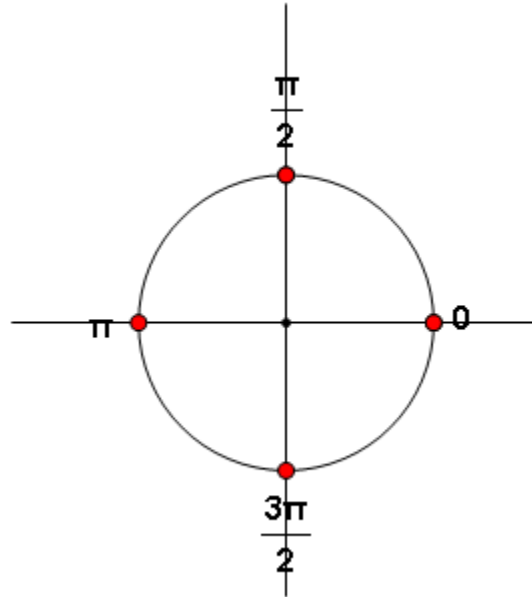

The terminal points for angles 0 , $\frac{\pi}{2}$, π , and $\frac{3\pi}{2}$ are shown on the unit circle. The coordinates of these points are easy to determine.

Give other angles that also have each of those points as terminal points. For example, $-\frac{3\pi}{2}$ is also associated with the point $(0, 1)$.

Step 2: What are the terminal points for $\frac{\pi}{4}$, $\frac{3\pi}{4}$, $\frac{5\pi}{4}$, and $\frac{7\pi}{4}$?

The green points on the unit circle divide the circle into 8 congruent arcs. **Explain how the number adjacent to each point is determined.**

Now let's determine the coordinates of the point associated with $\frac{\pi}{4}$. The coordinates of this point must

satisfy the equation $x^2 + y^2 = 1$. This point is also located on the line $y = x$. Use these two pieces of

Georgia Department of Education
Georgia Standards of Excellence Framework
GSE Pre-Calculus • Unit 1

information to determine the coordinates of this point.

After you find the coordinates for the terminal point of $\frac{\pi}{4}$, use what you know about the symmetry of the unit circle to determine the coordinates of the points in Quadrants II, III, and IV

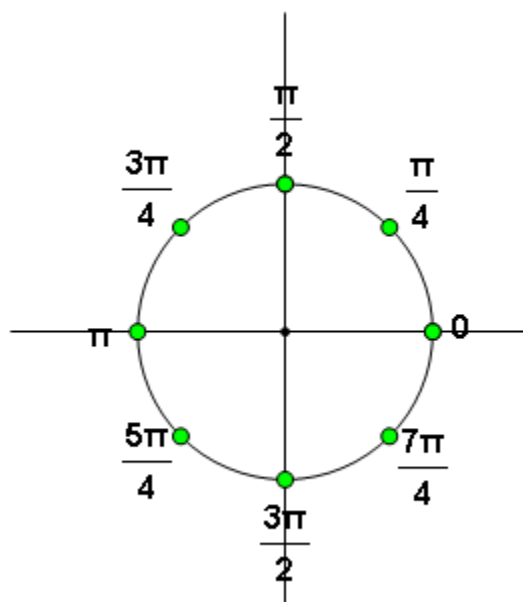

Step 3: What are the terminal points for

angles $\frac{\pi}{6}$, $\frac{\pi}{3}$, $\frac{2\pi}{3}$, $\frac{5\pi}{6}$, $\frac{7\pi}{6}$, $\frac{4\pi}{3}$, $\frac{5\pi}{3}$, and

$\frac{11\pi}{6}$?

The blue points on the unit circle divide the circle into 12 congruent arcs. **Explain how the number adjacent to each point is determined.**

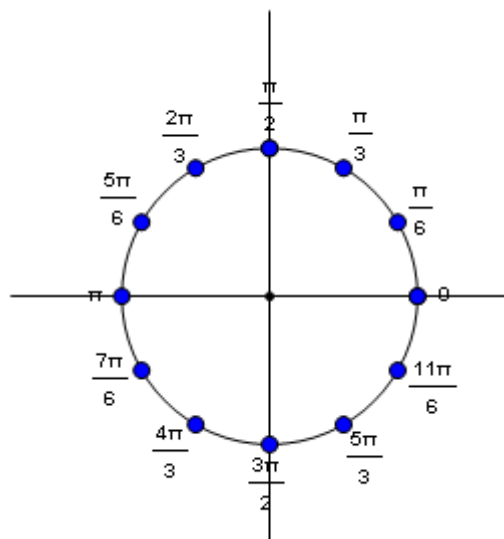

Now we need to determine the coordinates of these points. It will be sufficient for us to determine the coordinates of the points associated with $\frac{\pi}{6}$ and $\frac{\pi}{3}$. The symmetry of the unit circle will be used to determine the other coordinates.

In the figure, point D is the terminal point for

arc $\frac{\pi}{6}$. Angle DCB is 30° . Why? A

perpendicular segment has been drawn from D to the x-axis to create $\triangle BCD$. This triangle is a 30° - 60° - 90° triangle, one of the special right triangles studied in Analytic Geometry.

Explain why $\triangle BCD$ is a 30° - 60° - 90° triangle.

Because \overline{CD} is the radius of the unit circle, we know $CD = 1$. Using relationships in a 30° -

60° - 90° triangle, we can conclude $DB = \frac{1}{2}$

and $CB = \frac{\sqrt{3}}{2}$. This means the coordinates of

point B and point D are $\left(\frac{\sqrt{3}}{2}, 0\right)$ and

$\left(\frac{\sqrt{3}}{2}, \frac{1}{2}\right)$, respectively. Thus, we now know

the terminal point for angle $\frac{\pi}{6}$ is $\left(\frac{\sqrt{3}}{2}, \frac{1}{2}\right)$.

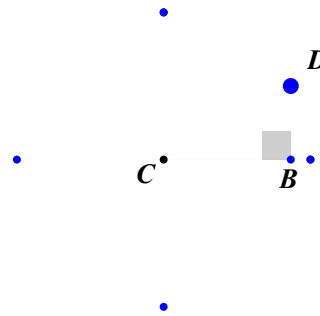

Georgia Department of Education
Georgia Standards of Excellence Framework
GSE Pre-Calculus • Unit 1

Now let's determine the coordinates of the terminal point of angle $\frac{\pi}{3}$. In the figure,

point H is the terminal point of $\frac{\pi}{3}$. Explain

why $\angle HCF$ is 60° . Segment HF has been drawn perpendicular to the x-axis to create $\triangle HCF$, a 30° - 60° - 90° triangle. Because \overline{CH} is a radius of the unit circle, $CH = 1$. Using relationships in a 30° - 60° - 90° triangle, we can

conclude $CF = \frac{1}{2}$ and $FH = \frac{\sqrt{3}}{2}$. This

means the coordinates of points F and H are

$\left(\frac{1}{2}, 0\right)$ and $\left(\frac{1}{2}, \frac{\sqrt{3}}{2}\right)$, respectively. Thus,

we now know the terminal point for angle $\frac{\pi}{3}$

is $\left(\frac{1}{2}, \frac{\sqrt{3}}{2}\right)$.

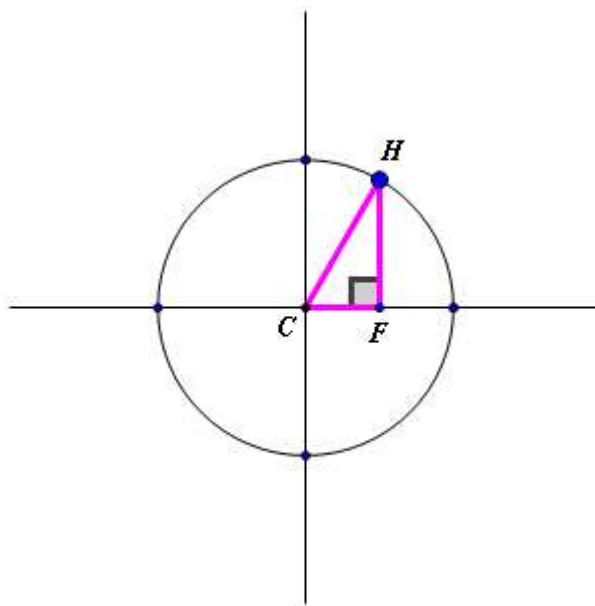

Georgia Department of Education
 Georgia Standards of Excellence Framework
GSE Pre-Calculus • Unit 1

The coordinates for $\frac{\pi}{6}$ and $\frac{\pi}{3}$ are recorded on the unit circle on the right. Use the symmetry of the unit circle to determine the coordinates of all terminal points identified in the figure.

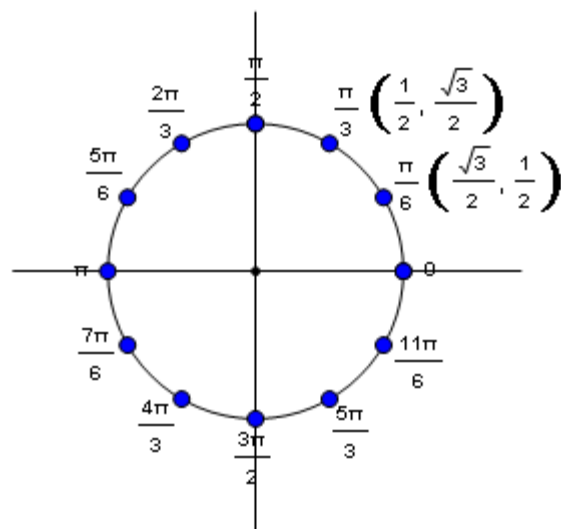

What observations can you make about these points and their angles?

The unit circle with all the special real numbers between 0 and 2π is shown.

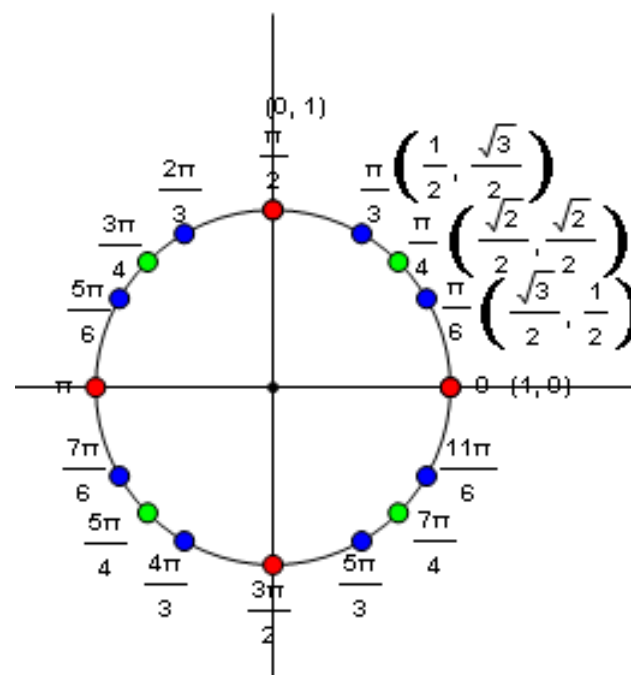

Georgia Department of Education
Georgia Standards of Excellence Framework
GSE Pre-Calculus • Unit 1

Let's determine the terminal point for $\frac{9\pi}{4}$. Since $\frac{9\pi}{4}$ is $\frac{9}{4}\pi$ or $2\frac{1}{4}\pi$, then this is equivalent to traversing the unit circle, beginning at $(1,0)$, in a counterclockwise direction 1 complete rotation (for 2π) and then $\frac{1}{4}\pi$ more. This means the terminal point for $\frac{9\pi}{4}$ is the same as that for $\frac{\pi}{4}$. So $\frac{9\pi}{4}$ has terminal point $\left(\frac{\sqrt{2}}{2}, \frac{\sqrt{2}}{2}\right)$.

To determine the terminal point for $-\frac{4\pi}{3}$, we can think about going in a clockwise direction a distance of $1\frac{2}{3}\pi$. This puts us in Quadrant II at the same point where $\frac{2\pi}{3}$ terminates. The coordinates of this point are $\left(-\frac{1}{2}, \frac{\sqrt{3}}{2}\right)$, and we can use the coordinates of $\frac{\pi}{3}$ to help us see this. So the terminal point of $-\frac{4\pi}{3}$ is

$$\left(-\frac{1}{2}, \frac{\sqrt{3}}{2}\right).$$

In the above examples the terminal points associated with $\frac{\pi}{4}$ and $\frac{\pi}{3}$ were used to help determine the terminal points of $\frac{9\pi}{4}$ and $-\frac{4\pi}{3}$, respectively. We call $\frac{\pi}{4}$ and $\frac{\pi}{3}$ **reference numbers**. To find the terminal point for any real number, we need only to know the terminal point of the reference number.

Reference Number

Let t be a real number. The reference number t' associated with t is the shortest distance along the unit circle between the terminal point determined by t and the x-axis. The reference number is always positive.

To determine the terminal point associated with real number t , determine the terminal point for its reference number. Affix the correct signs to the x-coordinate and y-coordinate based on the quadrant in which t terminates.

Georgia Department of Education
Georgia Standards of Excellence Framework
GSE Pre-Calculus • Unit 1

EXAMPLE: $\frac{17\pi}{6}$ is $2\frac{5}{6}\pi$ so it terminates in Quadrant II. Its reference number is $\frac{\pi}{6}$. Thus, the

terminal point for $\frac{17\pi}{6}$ is $\left(-\frac{\sqrt{3}}{2}, \frac{1}{2}\right)$.

Determine the terminal point for each real number.

a. $\frac{8\pi}{3}$

e. $-\frac{2\pi}{3}$

b. $-\frac{11\pi}{6}$

f. 5π

c. $\frac{7\pi}{6}$

g. $\frac{3\pi}{4}$

d. $\frac{-7\pi}{4}$

h. $\frac{10\pi}{3}$

Trigonometric Functions on the Unit Circle

Mathematical Goals

- Develop the concepts of sine and cosine in terms of the unit circle.
- Approximate values of the sine and cosine of a real number using a calibrated unit circle.
- Evaluate the sine and cosine of real numbers using a calculator.
- Use the reference number to determine the exact value of a special real number.

Georgia Standards of Excellence

MGSE9-12.F.TF.2 Explain how the unit circle in the coordinate plane enables the extension of trigonometric functions to all real numbers, interpreted as radian measures of angles traversed counterclockwise around the unit circle.

Standards for Mathematical Practice

- Make sense of problems and persevere in solving them.
- Reason abstractly and quantitatively.
- Construct viable arguments and critique the reasoning of others.
- Model with mathematics.
- Use appropriate tools strategically.
- Attend to precision.
- Look for and make use of structure.
- Look for and express regularity in repeated reasoning.

Introduction

In this task we define trigonometric functions in terms of the unit circle.

Materials

Calculator

Georgia Department of Education
Georgia Standards of Excellence Framework
GSE Pre-Calculus • Unit 1

In Analytic Geometry the trigonometric functions were defined in terms of a right triangle. In this task we define trigonometric functions in terms of the unit circle. This allows us to extend trigonometric functions to all real numbers. In previous tasks much time was spent connecting a real number to the radian measure of an angle to the length of the intercepted arc on the unit circle to the terminal point of this intercepted arc.

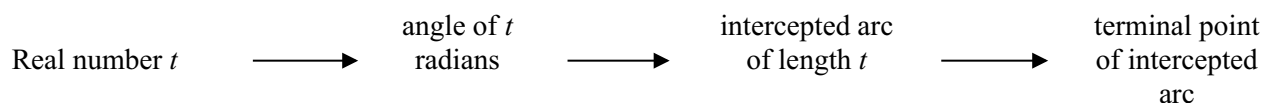

Another connection will now be made with the definitions of the sine and cosine functions in terms of the unit circle.

The ***sine of a real number t*** is the y-coordinate of its terminal point on the unit circle.

The ***cosine of a real number t*** is the x-coordinate of its terminal point on the unit circle.

1. In an earlier task, we used the calibrated unit circle below to estimate terminal points associated with a real number. We found the terminal point for real number 4.1 (that corresponds to 4.1 radians and arc of 4.1) was approximately $(-0.57, -0.82)$. Therefore, the sine of 4.1 is approximately -0.82 and the cosine of 4.1 is approximately -0.57 . We use the following shorthand to express this:

$$\sin(4.1) \approx -0.82 \quad \text{or} \quad \sin 4.1 \approx -0.82$$

$$\cos(4.1) \approx -0.57 \quad \text{or} \quad \cos 4.1 \approx -0.57$$

Georgia Department of Education
 Georgia Standards of Excellence Framework
 GSE Pre-Calculus • Unit 1

2. Use the calibrated unit circle below to estimate the following values:

- a. $\sin 2$
- b. $\sin 0.3$
- c. $\cos 5$
- d. $\cos (-2)$

3. Use the calibrated unit circle shown to approximate all real numbers t between 0 and 2π such that

- a. $\sin t = 0.8$.
- b. $\sin t = -0.4$
- c. $\cos t = 0.3$
- d. $\cos t = -0.8$

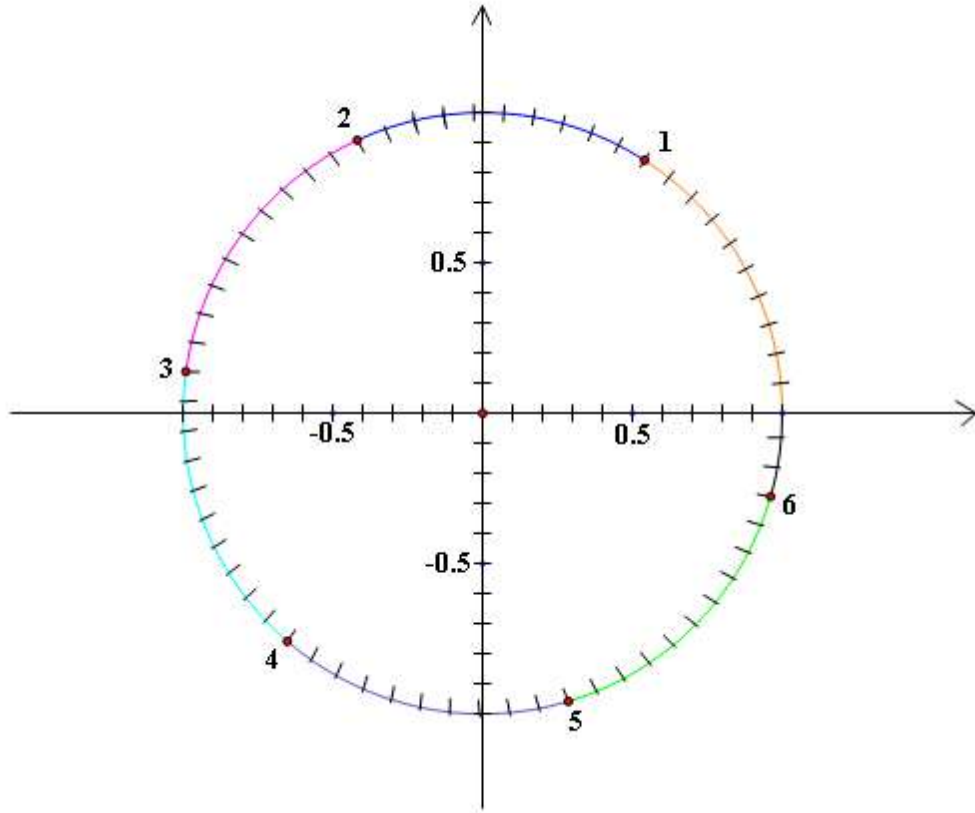

4. Determine the **exact** values of the following.

- a. $\sin \frac{3\pi}{4}$ $\frac{\sqrt{2}}{2}$
- b. $\sin \left(-\frac{\pi}{6}\right)$ $-1/2$
- c. $\cos \frac{7\pi}{4}$ $\frac{\sqrt{2}}{2}$
- d. $\cos \left(-\frac{3\pi}{2}\right)$ 0

5. Use your calculator set to radian mode to approximate the following values.

- a. $\sin (4.1)$ -0.818
- b. $\cos (-2.4)$ -0.737
- c. Point A is the terminal point on the unit circle associated with real number $\frac{\pi}{5}$. What are the coordinates of this point? $(0.809, 0.588)$
- d. Point B is the terminal point on the unit circle associated with real number $-\frac{7\pi}{8}$. What are the coordinates of this point? $(-0.924, -0.383)$

Be sure students are making the connection that if t is a real number and $P(x, y)$ is the terminal point on the unit circle paired with t , then another way to express P is $(\cos t, \sin t)$ ----this follows from how sine and cosine are defined in terms of the unit circle.

Georgia Department of Education
Georgia Standards of Excellence Framework
GSE Pre-Calculus • Unit 1

The tangent, secant, cosecant, and cotangent of a real number t can be defined in terms of $\sin t$ and $\cos t$.

$$\tan t = \frac{\sin t}{\cos t} \text{ where } \cos t \neq 0$$

$$\sec t = \frac{1}{\cos t} \text{ where } \cos t \neq 0$$

$$\csc t = \frac{1}{\sin t} \text{ where } \sin t \neq 0$$

$$\cot t = \frac{\cos t}{\sin t} = \frac{1}{\tan t} \text{ where } \sin t \neq 0$$

6. Determine the exact values of the following.

a. $\sin \frac{3\pi}{4} = \underline{\hspace{2cm}} \quad \frac{\sqrt{2}}{2}$

b. $\cos \frac{\pi}{3} = \underline{\hspace{2cm}} \quad 1/2$

c. $\tan 2\pi = \underline{\hspace{2cm}} \quad 0$

d. $\csc \frac{7\pi}{3} = \underline{\hspace{2cm}} \quad \frac{2}{\sqrt{3}} \text{ or } \frac{2\sqrt{3}}{3}$

e. $\sec \frac{7\pi}{4} = \underline{\hspace{2cm}} \quad \frac{2}{\sqrt{2}} \text{ or } \sqrt{2}$

f. $\cot \frac{7\pi}{6} = \underline{\hspace{2cm}} \quad \sqrt{3}$

7. Using a scientific or graphing calculator, you can quite easily find the sine, cosine and tangent of a given real number. This is not true for secant, cosecant, or cotangent. Since the three new trigonometric ratios are not on a calculator, how can you use the definitions of these functions to calculate the values?

To find the value of the cosecant of a number, first find the sine of the number and then find its reciprocal value.

Comment: Be sure students know that the \sin^{-1} button on the calculator does not mean the reciprocal of the sine value. In Analytic Geometry they used \sin^{-1} to determine angle measures in a right triangle. You can explain that \sin^{-1} , the inverse of the sine function, will be studied in a later unit. Stress that “inverse” and “reciprocal” have different meanings and are not identical concepts.

To find the secant of a number, find the reciprocal of the cosine value. To find the cotangent value, find the reciprocal of the tangent.

Use a calculator to approximate the following values. Be sure your calculator is in radian mode before proceeding.

Georgia Department of Education
Georgia Standards of Excellence Framework
GSE Pre-Calculus • Unit 1

a. $\csc \frac{\pi}{5} = \underline{\hspace{2cm}} \mathbf{1.7013}$

c. $\cot \frac{13\pi}{12} = \underline{\hspace{2cm}} \mathbf{3.7321}$

b. $\sec \frac{8\pi}{9} = \underline{\hspace{2cm}} \mathbf{-1.0641}$

d. $\cos \frac{19\pi}{10} = \underline{\hspace{2cm}} \mathbf{0.9511}$

Trigonometric Functions on the Unit Circle

In Analytic Geometry the trigonometric functions were defined in terms of a right triangle. In this task we define trigonometric functions in terms of the unit circle. This allows us to extend trigonometric functions to all real numbers. In previous tasks much time was spent connecting a real number to the radian measure of an angle to the length of the intercepted arc on the unit circle to the terminal point of this intercepted arc.

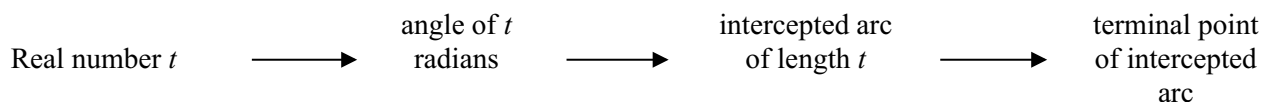

Another connection will now be made with the definitions of the sine and cosine functions in terms of the unit circle.

The *sine of a real number t* is the y-coordinate of its terminal point on the unit circle.

The *cosine of a real number t* is the x-coordinate of its terminal point on the unit circle.

1. In an earlier task, we used the calibrated unit circle below to estimate terminal points associated with a real number. We found the terminal point for real number 4.1 (that corresponds to 4.1 radians and arc of 4.1) was approximately $(-0.57, -0.82)$. Therefore, the sine of 4.1 is approximately -0.82 and the cosine of 4.1 is approximately -0.57 . We use the following shorthand to express this:

$$\sin(4.1) \approx -0.82 \quad \text{or} \quad \sin 4.1 \approx -0.82$$

$$\cos(4.1) \approx -0.57 \quad \text{or} \quad \cos 4.1 \approx -0.57$$

Georgia Department of Education
 Georgia Standards of Excellence Framework
 GSE Pre-Calculus • Unit 1

2. Use the calibrated unit circle below to estimate the following values:
- $\sin 2$
 - $\sin 0.3$
 - $\cos 5$
 - $\cos (-2)$
3. Use the calibrated unit circle shown to approximate all real numbers t between 0 and 2π such that
- $\sin t = 0.8$.
 - $\sin t = -0.4$
 - $\cos t = 0.3$
 - $\cos t = -0.8$

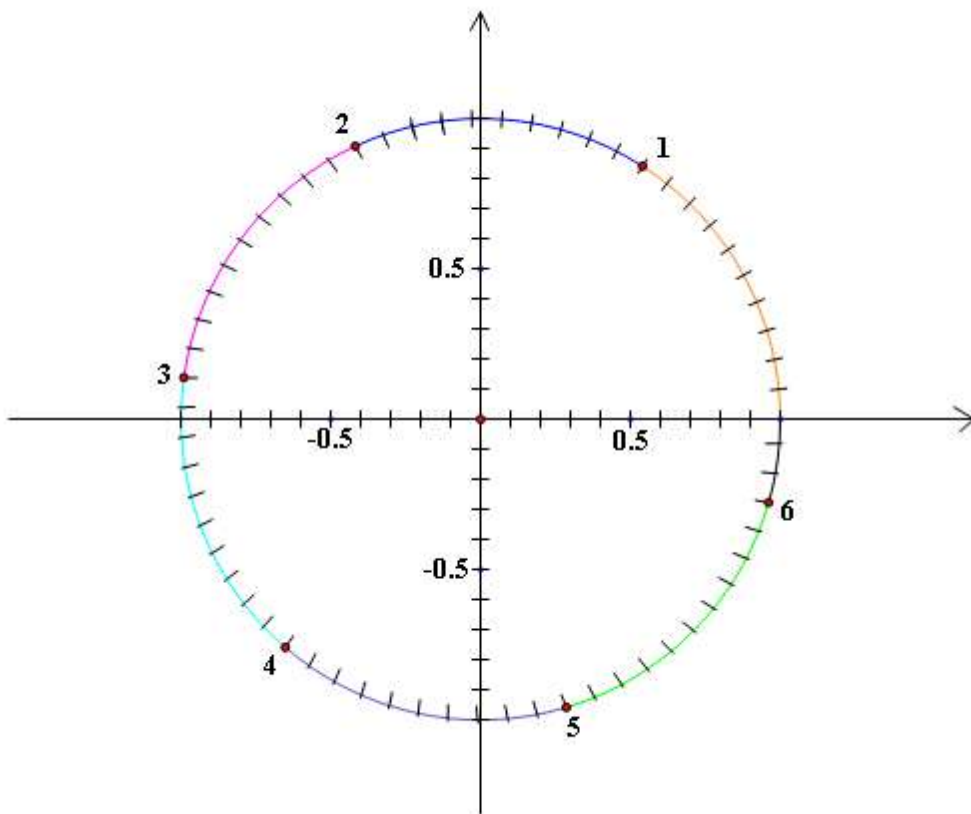

4. Determine the **exact** values of the following.
- $\sin \frac{3\pi}{4}$
 - $\sin \left(-\frac{\pi}{6} \right)$
 - $\cos \frac{7\pi}{4}$
 - $\cos \left(-\frac{3\pi}{2} \right)$
5. Use your calculator set to radian mode to approximate the following values.
- $\sin (4.1)$
 - $\cos (-2.4)$
 - Point A is the terminal point on the unit circle associated with real number $\frac{\pi}{5}$. What are the coordinates of this point?
 - Point B is the terminal point on the unit circle associated with real number $-\frac{7\pi}{8}$. What are the coordinates of this point?

Georgia Department of Education
Georgia Standards of Excellence Framework
GSE Pre-Calculus • Unit 1

The tangent, secant, cosecant, and cotangent of a real number t can be defined in terms of $\sin t$ and $\cos t$.

$$\tan t = \frac{\sin t}{\cos t} \text{ where } \cos t \neq 0$$

$$\sec t = \frac{1}{\cos t} \text{ where } \cos t \neq 0$$

$$\csc t = \frac{1}{\sin t} \text{ where } \sin t \neq 0$$

$$\cot t = \frac{\cos t}{\sin t} = \frac{1}{\tan t} \text{ where } \sin t \neq 0$$

6. Determine the exact values of the following.

a. $\sin \frac{3\pi}{4} =$ _____

b. $\cos \frac{\pi}{3} =$ _____

c. $\tan 2\pi =$ _____

d. $\csc \frac{7\pi}{3} =$ _____

e. $\sec \frac{7\pi}{4} =$ _____

f. $\cot \frac{7\pi}{6} =$ _____

7. Using a scientific or graphing calculator, you can quite easily find the sine, cosine and tangent of a given real number. This is not true for secant, cosecant, or cotangent. Since the three new trigonometric ratios are not on a calculator, how can you use the definitions of these functions to calculate the values?

Use a calculator to approximate the following values. Be sure your calculator is in radian mode before proceeding.

a. $\csc \frac{\pi}{5} =$ _____

b. $\sec \frac{8\pi}{9} =$ _____

c. $\cot \frac{13\pi}{12} =$ _____

d. $\cos \frac{19\pi}{10} =$ _____

UnWrapping the Unit Circle³

This task and the one following “Exploring the Sine and Cosine Graphs,” accomplish similar purposes. This task, “UnWrapping the Unit Circle,” is more interactive and helps students see that by matching coordinates from the unit circle to the number line, the sine and cosine graphs are created.

Mathematical Goals

- Graph the sine and cosine functions
- Determine the characteristics of the sine and cosine function
- Define amplitude, midline, and period

Georgia Standards of Excellence

~~MGSE9-12.F.IF.7e Graph exponential and logarithmic functions, showing intercepts and end behavior, and~~ trigonometric functions, showing period, midline, and amplitude.

Standards for Mathematical Practice

- Make sense of problems and persevere in solving them.
- Reason abstractly and quantitatively.
- Construct viable arguments and critique the reasoning of others.
- Model with mathematics.
- Use appropriate tools strategically.
- Attend to precision.
- Look for and make use of structure.
- Look for and express regularity in repeated reasoning.

Introduction

In this task the students use a hands-on activity to generate the graphs of the sine and cosine function by matching coordinates from the unit circle to the number line.

Materials:

- Bulletin Board paper or butcher paper (approximately 8 feet long)
- Uncooked spaghetti

³ Illuminations: Resources for Teaching Mathematics, National Council of Teachers of Mathematics

- Masking tape
- Protractor
- Meter stick
- Colored marker
- Twine, rope, or yarn (about 7 feet long)

Part I: Unwrapping the Sine Curve

Tape the paper to the floor, and construct the diagram below. The circle's radius should be about the length of one piece of uncooked spaghetti. If your radius is smaller, break the spaghetti to the length of the radius. This is a unit circle with the spaghetti equal to one unit.

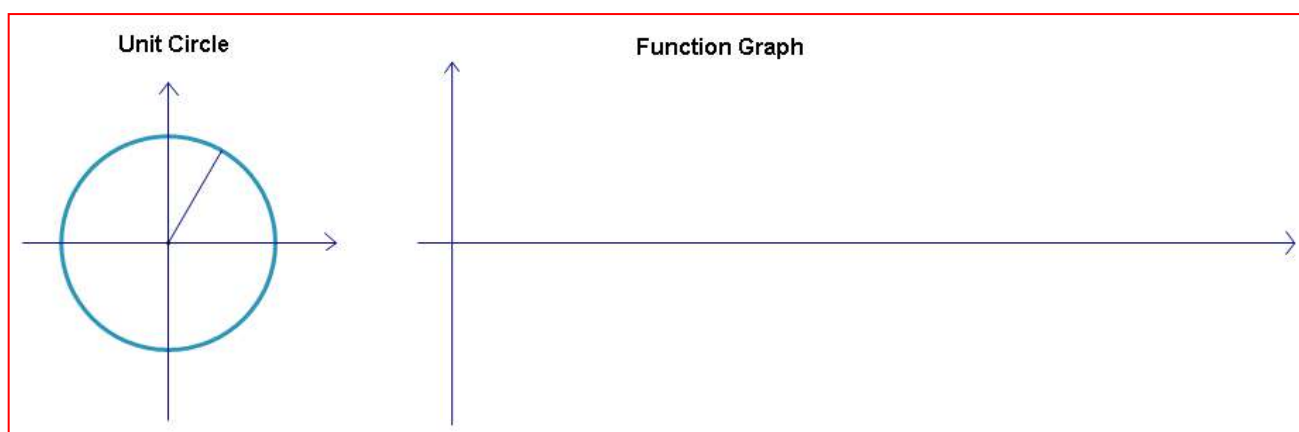

Using a protractor, make marks every 15° around the unit circle. Place a string on the unit circle at 0 radians, which is at the point $(1, 0)$ and wrap it counterclockwise around the circle. Transfer the marks from the circle to the string.

1. How much is 15° in radians? _____ *$\pi/12$ radians*

Transfer the marks on the string onto the x -axis of the function graph. The end of the string that was at the point $(1, 0)$ must be placed at the origin of the function graph. Label these marks on the x -axis with the related angle measures from the unit circle (e.g., 0 radians, $\frac{\pi}{12}$ radians, $\frac{\pi}{6}$ radians, etc.).

2. What component from the unit circle do the x -values on the function graph represent?

x -values = _____ *the radian measures of the angles*

Georgia Department of Education
Georgia Standards of Excellence Framework
GSE Pre-Calculus • Unit 1

Use the length of your spaghetti to mark one unit above and below the origin on the y -axis of the function graph. Label these marks 1 and -1 , respectively.

Draw a right triangle in the unit circle where the hypotenuse is the radius of the circle to the $\frac{\pi}{12}$ radians mark and the legs lie along and perpendicular to the x -axis.

Break a piece of spaghetti to the length of the vertical leg of this triangle, from the $\frac{\pi}{12}$ radians mark on the circle to the x -axis. Let this piece of spaghetti represent the y -value for the point on the function graph where $x = \frac{\pi}{12}$ radians. Place the spaghetti piece appropriately on the function graph and make a dot at the top of it. **Note:** Since this point is above the x -axis in the unit circle, the corresponding point on the function graph should also be above the x -axis.

Transferring the Spaghetti for the Triangle Drawn to the $\frac{\pi}{3}$ radians Mark

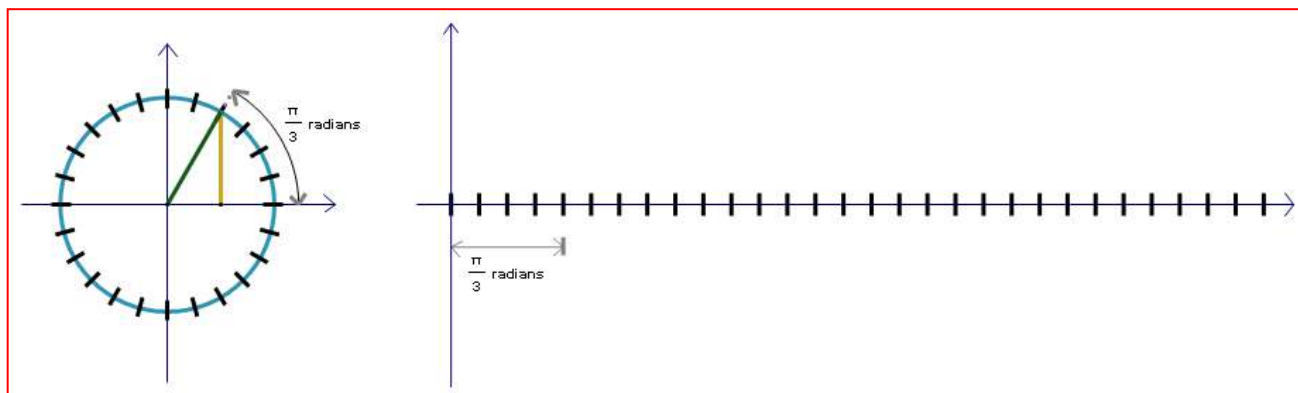

Continue constructing triangles and transferring lengths for all marks on the unit circle. After you have constructed all the triangles, transferred the lengths of the vertical legs to the function graph, and added the dots, draw a smooth curve to connect the dots.

3. The vertical leg of a triangle in the unit circle, which is the y -value on the function graph, represents what function of the related angle measure?

y -coordinates = _____ *sine*

Label the function graph you just created on your butcher paper $y = \sin x$.

4. What is the period of the sine curve? That is, what is the wavelength? After how many radians does the graph start to repeat? How do you know it repeats after this point?

2π – This is one rotation around the unit circle. After this it repeats because it is just going around the same unit circle again.

5. What are the zeroes of this function? (Remember: The x -values are measuring angles and zeroes are the x -intercepts.)

$0, \pi, 2\pi$

6. What are the x -values at the maxima and minima of this function?

$\frac{\pi}{2}$ and $\frac{3\pi}{2}$

7. What are the y -values at the maxima and minima?

1 and -1

8. Imagine this function as it continues in both directions. Explain how you can predict the value of the sine of $\frac{13\pi}{6}$.

$\sin \frac{13\pi}{6} = \sin \frac{\pi}{6}$ – *Explanations will vary. The two angles have the same terminal point so they have the same sine value.*

9. Explain why $\sin \frac{\pi}{6} = \sin \frac{5\pi}{6}$. Refer to both the unit circle and the graph of the sine curve.

Explanations will vary. Students should discuss the related heights on the unit circle and the nature of the curve of the function graph.

Part II: Unwrapping the Cosine Curve

You used the length of the vertical leg of a triangle in the unit circle to find the related y -value in the sine curve. Determine what length from the unit circle will give you the y -value for a cosine curve. Using a different color, create the graph on your butcher paper and label it $y = \cos x$.

10. In what ways are the sine and cosine graphs similar? Be sure to include a discussion of intercepts, maxima, minima, and period.

Answers may vary but should include: same overall shape, both have a range from -1 to 1, and both have a period of 2π . Students may include details such as x -intercepts are π units apart and both have maximum and minimum values of 1 and -1, respectively.

11. In what ways are the sine and cosine graphs different? Again, be sure to include a discussion of intercepts, maxima, minima, and period.

Answers may vary but should include: y -intercept is at 0 for sine and at 1 for cosine, x -intercepts for one occur at the maxima or minima for the other.

12. Will sine graphs continue infinitely in either direction? How do you know? Identify the domain and range of $y = \sin x$.

*Domain: all real numbers or $(-\infty, \infty)$
Range: $[-1, 1]$ or $-1 \leq y \leq 1$*

Georgia Department of Education
Georgia Standards of Excellence Framework
GSE Pre-Calculus • Unit 1

13. Will cosine graphs continue infinitely in either direction? How do you know? Identify the domain and range of $y = \cos x$.

Domain: all real numbers or $(-\infty, \infty)$

Range: $[-1, 1]$ or $-1 \leq y \leq 1$

UnWrapping the Unit Circle⁴

Materials:

- Bulletin Board paper or butcher paper (approximately 8 feet long)
- Uncooked spaghetti
- Masking tape
- Protractor
- Meter stick
- Colored marker
- Twine, rope, or yarn (about 7 feet long)

Part I: Unwrapping the Sine Curve

Tape the paper to the floor, and construct the diagram below. The circle's radius should be about the length of one piece of uncooked spaghetti. If your radius is smaller, break the spaghetti to the length of the radius. This is a unit circle with the spaghetti equal to one unit.

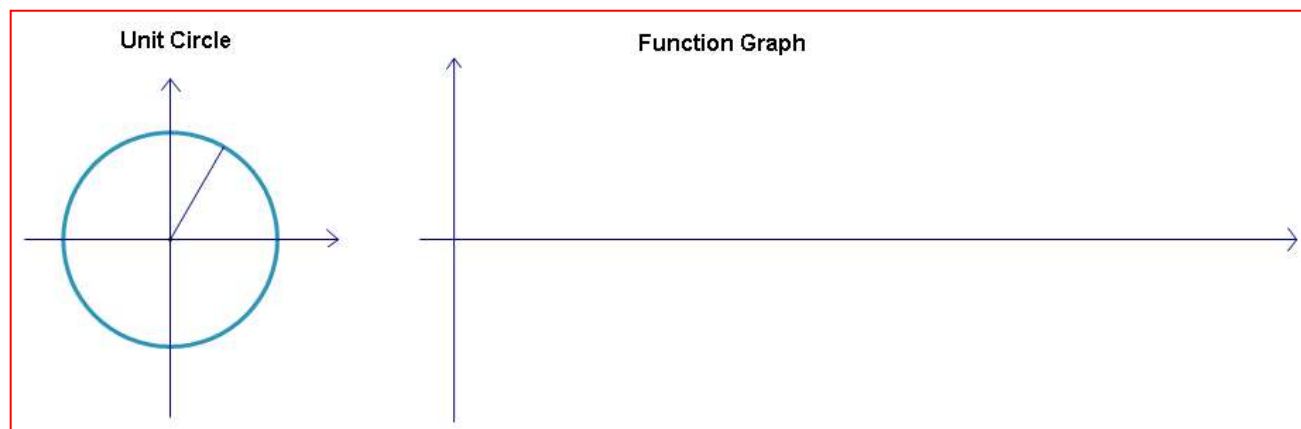

Using a protractor, make marks every 15° around the unit circle. Place a string on the unit circle at 0 radians, which is at the point (1, 0) and wrap it counterclockwise around the circle. Transfer the marks from the circle to the string.

1. How much is 15° in radians? _____

⁴ Illuminations: Resources for Teaching Mathematics, National Council of Teachers of Mathematics

Transfer the marks on the string onto the x -axis of the function graph. The end of the string that was at the point $(1, 0)$ must be placed at the origin of the function graph. Label these marks on the x -axis with the related angle measures from the unit circle (e.g., 0 radians, $\frac{\pi}{12}$ radians, $\frac{\pi}{6}$ radians, etc.).

2. What component from the unit circle do the x -values on the function graph represent?

x -values = _____

Use the length of your spaghetti to mark one unit above and below the origin on the y -axis of the function graph. Label these marks 1 and -1 , respectively.

Draw a right triangle in the unit circle where the hypotenuse is the radius of the circle to the $\frac{\pi}{12}$ radians mark and the legs lie along and perpendicular to the x -axis.

Break a piece of spaghetti to the length of the vertical leg of this triangle, from the $\frac{\pi}{12}$ radians mark on the circle to the x -axis. Let this piece of spaghetti represent the y -value for the point on the function graph where $x = \frac{\pi}{12}$ radians. Place the spaghetti piece appropriately on the function graph and make a dot at the top of it. **Note:** Since this point is above the x -axis in the unit circle, the corresponding point on the function graph should also be above the x -axis.

Transferring the Spaghetti for the Triangle Drawn to the $\frac{\pi}{3}$ radians Mark

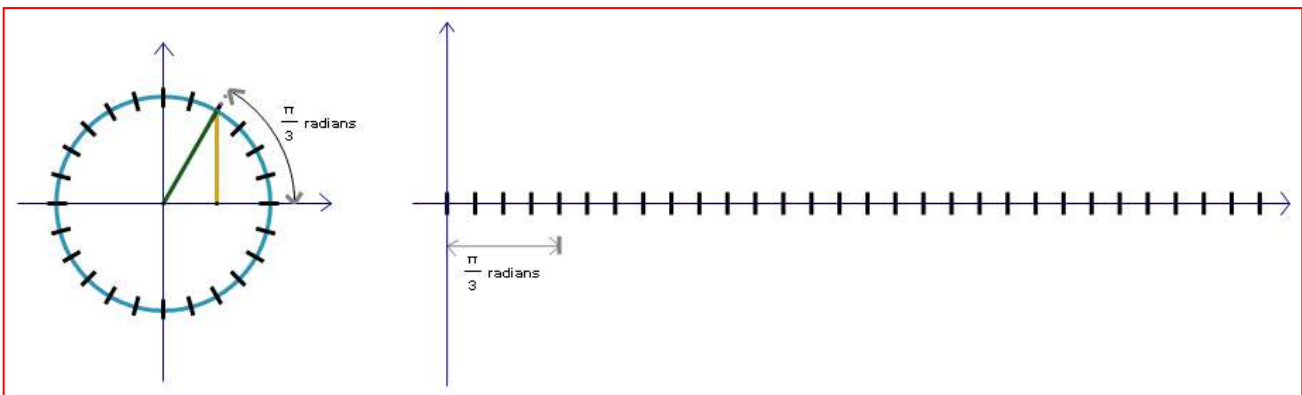

Continue constructing triangles and transferring lengths for all marks on the unit circle. After you have constructed all the triangles, transferred the lengths of the vertical legs to the function graph, and added the dots, draw a smooth curve to connect the dots.

Georgia Department of Education
Georgia Standards of Excellence Framework
GSE Pre-Calculus • Unit 1

3. The vertical leg of a triangle in the unit circle, which is the y -value on the function graph, represents what function of the related angle measure?

y -coordinates = _____

Label the function graph you just created on your butcher paper $y = \sin x$.

4. What is the period of the sine curve? That is, what is the wavelength? After how many radians does the graph start to repeat? How do you know it repeats after this point?
5. What are the zeroes of this function? (Remember: The x -values are measuring angles and zeroes are the x -intercepts.)
6. What are the x -values at the maxima and minima of this function?
7. What are the y -values at the maxima and minima?
8. Imagine this function as it continues in both directions. Explain how you can predict the value of the sine of $\frac{13\pi}{6}$.
9. Explain why $\sin \frac{\pi}{6} = \sin \frac{5\pi}{6}$. Refer to both the unit circle and the graph of the sine curve.

Part II: Unwrapping the Cosine Curve

You used the length of the vertical leg of a triangle in the unit circle to find the related y -value in the sine curve. Determine what length from the unit circle will give you the y -value for a cosine curve. Using a different color, create the graph on your butcher paper and label it $y = \cos x$.

10. In what ways are the sine and cosine graphs similar? Be sure to include a discussion of intercepts, maxima, minima, and period.

11. In what ways are the sine and cosine graphs different? Again, be sure to include a discussion of intercepts, maxima, minima, and period.

12. Will sine graphs continue infinitely in either direction? How do you know? Identify the domain and range of $y = \sin x$.

13. Will cosine graphs continue infinitely in either direction? How do you know? Identify the domain and range of $y = \cos x$.

Exploring Sine and Cosine Graphs

This task and the preceding one, “UnWrapping the Unit Circle,” accomplish similar purposes. This task, Exploring Sine and Cosine Graphs is less interactive.

Mathematical Goals

- Graph the sine and cosine functions
- Determine the characteristics of the sine and cosine function
- Define amplitude, midline, period

Georgia Standards of Excellence

MGSE9-12.F.IF.7 Graph functions expressed algebraically and show key features of the graph both by hand and by using technology.

MGSE9-12.F.IF.7e Graph ~~exponential and logarithmic functions, showing intercepts and end behavior, and~~ trigonometric functions, showing period, midline, and amplitude.

Standards for Mathematical Practice

- Make sense of problems and persevere in solving them.
- Reason abstractly and quantitatively.
- Construct viable arguments and critique the reasoning of others.
- Model with mathematics.
- Use appropriate tools strategically.
- Attend to precision.
- Look for and make use of structure.
- Look for and express regularity in repeated reasoning.

Introduction

This task is designed to give students a chance to explore and make conjectures about the nature of the sine and cosine graphs. They are looking specifically for the following features: amplitude, period, frequency, horizontal shifts, and vertical shifts. They will continue to analyze graph features like x-and y-intercepts, domain and range, and maximum and minimum values.

Students are encouraged to develop these ideas by developing charts of data values and by using graphing technology. **Students are not expected to create all of these graphs by hand.** This is especially true for a problem like #9. While it is important for students to be able to create a graph of the trigonometric functions by hand, this should be done after they are able to identify the key features of the graph and can use these features to create the graph.

Georgia Department of Education
 Georgia Standards of Excellence Framework
 GSE Pre-Calculus • Unit 1

Materials

- Graphing calculators or a graphing utility on a computer

In a previous task you used your calculator to model periodic data using a sine graph. Now you will explore the sine and cosine graphs to determine the specific characteristics of these graphs.

- Use exact values from the unit circle to complete the following chart for $y = \sin x$ where x is a real number.

Be sure students understand that in $y = \sin x$, x represents a real number that is paired with a terminal point on the unit circle; y is the y -coordinate of that terminal point on the unit circle.

x	-2π	$-\frac{7\pi}{4}$	$-\frac{3\pi}{2}$	$-\frac{5\pi}{4}$	$-\pi$	$-\frac{3\pi}{4}$	$-\frac{\pi}{2}$	$-\frac{\pi}{4}$	0	$\frac{\pi}{4}$	$\frac{\pi}{2}$	$\frac{3\pi}{4}$	π	$\frac{5\pi}{4}$	$\frac{3\pi}{2}$	$\frac{7\pi}{4}$	2π
$\sin x$	0	$\frac{\sqrt{2}}{2}$	1	$\frac{\sqrt{2}}{2}$	0	$-\frac{\sqrt{2}}{2}$	-1	$-\frac{\sqrt{2}}{2}$	0	$\frac{\sqrt{2}}{2}$	1	$\frac{\sqrt{2}}{2}$	0	$-\frac{\sqrt{2}}{2}$	-1	$-\frac{\sqrt{2}}{2}$	0

- What do you notice about the values in the chart?

Possible answers: The numbers tend to repeat themselves. There is a pattern to the numbers as the angle increases. The highest values are 1. The lowest values are -1. It tends to cross the x -axis often.

- When does $\sin x = 1$? When does $\sin x = 0$?

$\sin x = 1$ when $x = -\frac{3\pi}{2}, \frac{\pi}{2}$

$\sin x = 0$ when $x = -2\pi, -\pi, 0, \pi, 2\pi$

Georgia Department of Education
Georgia Standards of Excellence Framework
GSE Pre-Calculus • Unit 1

2. Plot the data in the table on the grid below.

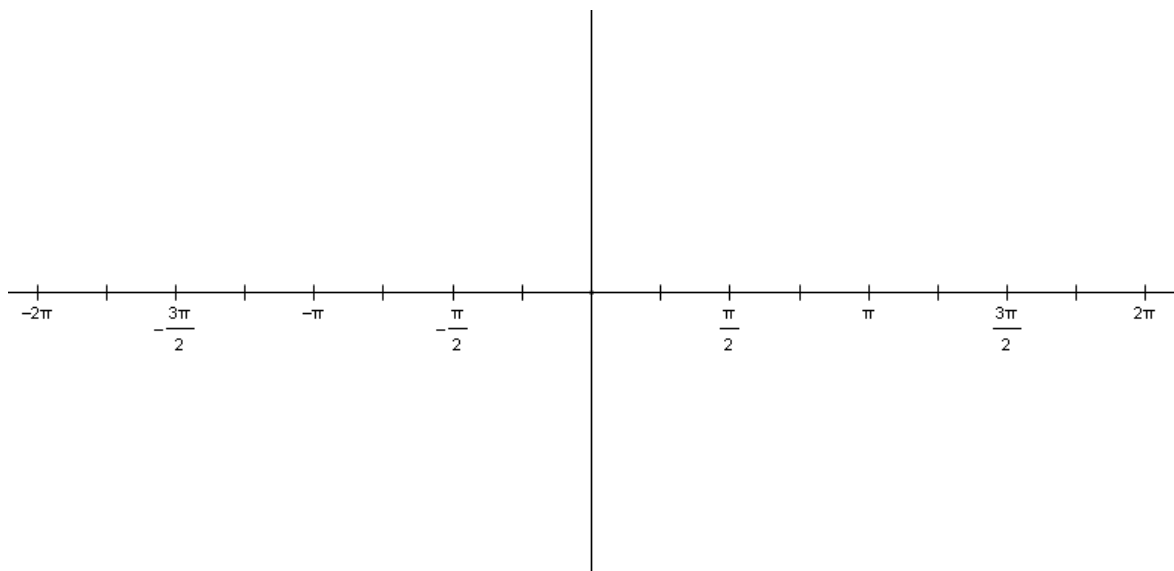

Students should use the exact values on the x-axes but will need to approximate some of the values for $\sin x$ so they can be plotted.

3. Study the graph to answer the following questions:
- Does $y = \sin x$ appear to be a periodic function? If so, what is its period?
Yes, the function is periodic. Its period is 2π .
 - What is the domain and range?
The domain is all real numbers. The range is -1 to 1.
 - What is the y-intercept?
The y-intercept is $(0,0)$.
 - Where do the x-intercepts occur?
The x-intercepts occur when $x = -2\pi, -\pi, 0, \pi, 2\pi$
 - What are the maximum values and where do they occur?
The maximum value is 1 which occurs when $x = -\frac{3\pi}{2}, \frac{\pi}{2}$

Georgia Department of Education
Georgia Standards of Excellence Framework
GSE Pre-Calculus • Unit 1

- f. What is the minimum value and where does it occur?

The maximum value is -1 which occurs when $x = -\frac{\pi}{2}, \frac{3\pi}{2}$

- g. How would your answers to questions d, e, and f change if your graph continued past 360° ?

Maximum value would occur at all $x = \frac{\pi}{2} + 2n\pi$ where n is an integer;

Minimum value would occur at all $x = \frac{3\pi}{2} + 2n\pi$ where n is an integer

- h. What is the midline? What is the amplitude?

The midline is a horizontal line located halfway between the maximum and minimum values. For $y = \sin x$, the midline is the line $y = 0$ (that is, the x -axis). Then amplitude is the distance from the midline to either the maximum or minimum value; it is $\frac{1}{2}$ the distance between the maximum and minimum values. The amplitude for $y = \sin x$ is 1.

Be sure students see that one cycle of $y = \sin x$ occurs over an interval of 2π units. If they look at the interval from 0 to 2π , there are 5 key points: the point that begins the cycle, the point located $\frac{1}{4}$ of the way through the cycle, the halfway point of the cycle, the $\frac{3}{4}$ point, and the ending point. For the parent graph $y = \sin x$, the beginning point is on the midline; it hits the maximum at the quarter point, crosses the midline at the halfway point, hits the minimum at the $\frac{3}{4}$ point, and returns to the midline at the ending point. In this basic cycle from 0 to 2π , the graph increases, decreases, increases, and decreases.

- i. The **frequency** of a trigonometric function is the number of cycles the function completes in a given interval. The frequency is related to the period and is defined to be the reciprocal of the period. $y = \sin x$ completes one cycle in a distance of 2π units so in 1 unit it completes $\frac{1}{2\pi}$ of a cycle. (Think about it this way: $2\pi \approx 6.28$. For the sake of explaining about frequency, let's say that $2\pi \approx 6$. Then $y = \sin x$ completes one complete cycle in about 6 units; thus, it completes about $\frac{1}{6}$ of a cycle in one unit; the frequency is about $\frac{1}{6}$.)

NOTE: $\frac{1}{2\pi} \approx \frac{1}{6.28} \approx \frac{1}{6}$)

Georgia Department of Education
 Georgia Standards of Excellence Framework
 GSE Pre-Calculus • Unit 1

4. Use exact values from the unit circle to complete the following chart for $y = \cos x$ where x is a real number. *Be sure students understand that in $y = \cos x$, x represents a real number that is paired with a terminal point on the unit circle; y is the x -coordinate of that terminal point on the unit circle.*

x	$-\frac{7\pi}{4}$	$-\frac{3\pi}{2}$	$-\frac{5\pi}{4}$	$-\pi$	$-\frac{3\pi}{4}$	$-\frac{\pi}{2}$	$-\frac{\pi}{4}$	0	$\frac{\pi}{4}$	$\frac{\pi}{2}$	$\frac{3\pi}{4}$	π	$\frac{5\pi}{4}$	$\frac{3\pi}{2}$	$\frac{7\pi}{4}$	2π
$\cos x$	$\frac{\sqrt{2}}{2}$	0	$-\frac{\sqrt{2}}{2}$	-1	$-\frac{\sqrt{2}}{2}$	0	$\frac{\sqrt{2}}{2}$	1	$\frac{\sqrt{2}}{2}$	0	$-\frac{\sqrt{2}}{2}$	-1	$-\frac{\sqrt{2}}{2}$	0	$\frac{\sqrt{2}}{2}$	1

5. Plot the data on the grid below.

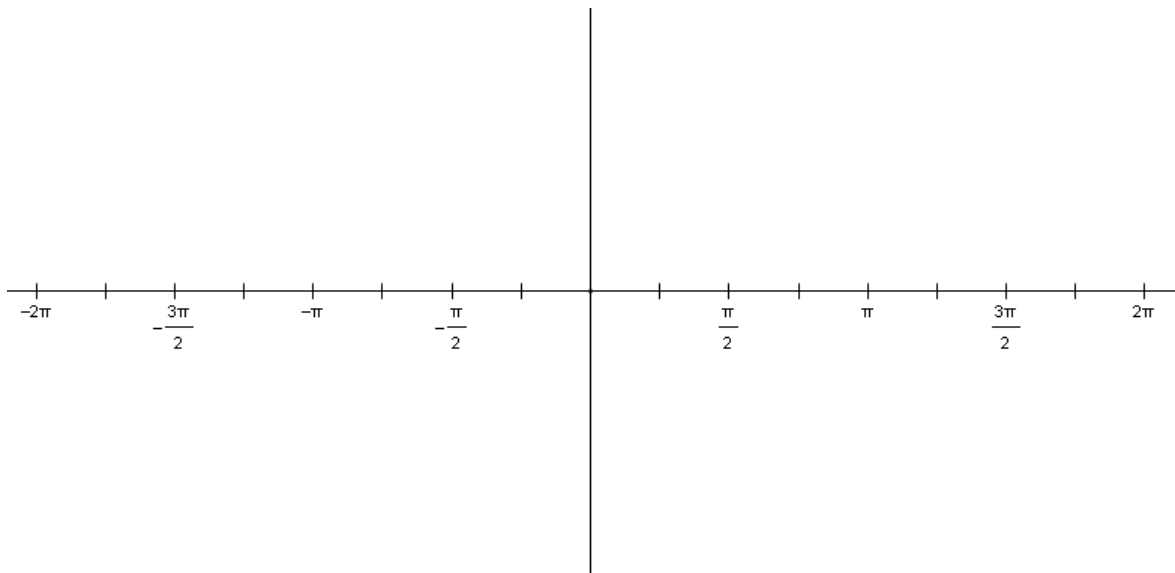

Students should use the exact values on the x -axes but will need to approximate some of the values for $\cos x$ so they can be plotted.

6. Study the graph of $y = \cos x$ to answer the following questions:
- What is the period?
The period is 2π .
 - What is the domain and range?
The domain is all real numbers. The range is -1 to 1.
 - What is the y-intercept?
The y-intercept is (0,1).
 - Where do the x-intercepts occur?
The x-intercepts occur when $x = -\frac{3\pi}{2}, -\frac{\pi}{2}, \frac{\pi}{2}, \frac{3\pi}{2}$.
 - What is the maximum value and where does it occur?
The maximum value is 1 which occurs when $x = -2\pi, 0$ and 2π . (Even multiples of π)
 - What is the minimum value and where does it occur?
The minimum value is -1 which occurs when $x = -\pi$ and π . (Odd multiples of π)
 - Picture your graph continuing past 2π . How would your answers to questions d, e, and f change?
The x-intercepts, maximum values, and minimum values would continue to occur at regular intervals.
 - Re-write your answers to d, e, and f so that you've included all possible values of x.
The x-intercepts occur when $x = \frac{\pi}{2} + n\pi$, where n is an integer.

The maximums and minimums occur every 2π radians.

Maximum occurs when $x = 2n\pi$ where n is an integer.

Minimum occurs when $x = \pi + 2n\pi$ where n is an integer.
 - What is the midline? What is the amplitude?
The midline is $y = 0$ (the x-axis) and the amplitude is 1.

Be sure students see that one cycle of $y = \cos x$ occurs over an interval of 2π units. If they look at the interval from 0 to 2π , there are 5 key points: the point that begins the cycle, the point located $\frac{1}{4}$ of the way through the cycle, the halfway point of the cycle, the $\frac{3}{4}$ point, and the ending point. For the parent graph $y = \cos x$, the beginning point is at the maximum; it crosses the midline at the quarter point, hits the minimum value at the halfway point, crosses the midline at the $\frac{3}{4}$ point, and has a maximum at the ending point. In this basic cycle from 0 to 2π , the graph decreases and then increases.

Georgia Department of Education
 Georgia Standards of Excellence Framework
 GSE Pre-Calculus • Unit 1

7. Use your graphing calculator to graph $y = \sin x$. Check your mode to make sure you are using radians and make sure you have an appropriate window for your data. Sketch the graph of $y = \sin x$ below. Make sure you draw a smooth curve. How does this graph compare to your hand-drawn graph in problem 2?

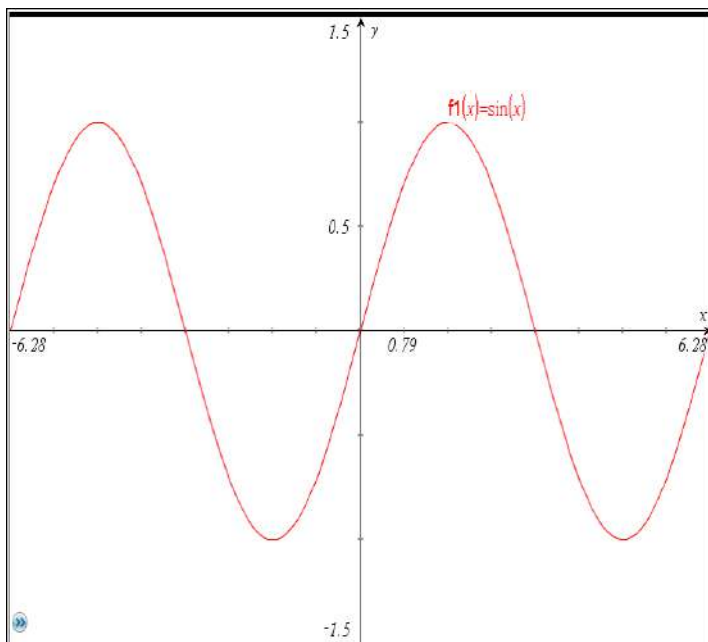

8. Use your graphing calculator to graph $y = \cos x$. Check your mode to make sure you are using radians and make sure you have an appropriate window for your data. Use the grid below to draw an accurate graph of $\cos x$. Make sure you draw a smooth curve. How does this graph compare to your hand-drawn graph in problem 5?

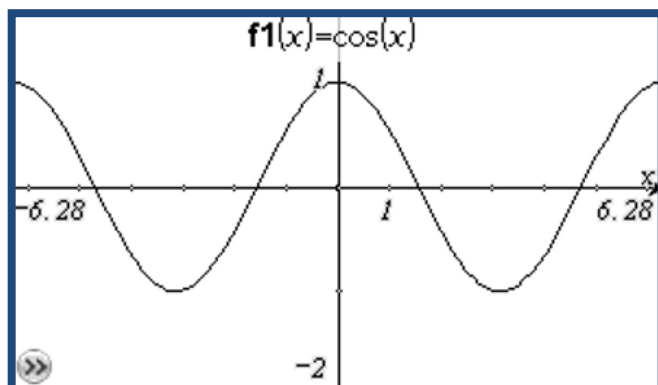

9. Using your calculator, graph $y = \sin x$ and $y = \cos x$ on the same axis. How are they alike? How are they different?
Answers may vary.

Similarities include: period, max, min, overall shape

Differences include: when x -intercepts, max and min's occur ; location of y -intercepts

10. Using what you have learned about the graphs of the sine and cosine functions, practice graphing the functions by hand. You should be able to quickly sketch the graphs of these functions, making sure to include zeroes, intercepts, maximums and minimums. Be sure to create a smooth curve!

Students should not move on until they feel comfortable sketching the sine and cosine graphs. They need to use their unit circles and their basic understanding of the shape of the graph to create these quick sketches.

Exploring Sine and Cosine Graphs

In a previous task you used your calculator to model periodic data using a sine graph. Now you will explore the sine and cosine graphs to determine the specific characteristics of these graphs.

- Use exact values from the unit circle to complete the following chart for $y = \sin x$ where x is a real number.

x	-2π	$-\frac{7\pi}{4}$	$-\frac{3\pi}{2}$	$-\frac{5\pi}{4}$	$-\pi$	$-\frac{3\pi}{4}$	$-\frac{\pi}{2}$	$-\frac{\pi}{4}$	0	$\frac{\pi}{4}$	$\frac{\pi}{2}$	$\frac{3\pi}{4}$	π	$\frac{5\pi}{4}$	$\frac{3\pi}{2}$	$\frac{7\pi}{4}$	2π
$\sin x$																	

- What do you notice about the values in the chart?
 - When does $\sin x = 1$? When does $\sin x = 0$?
- Plot the data in the table on the grid below.

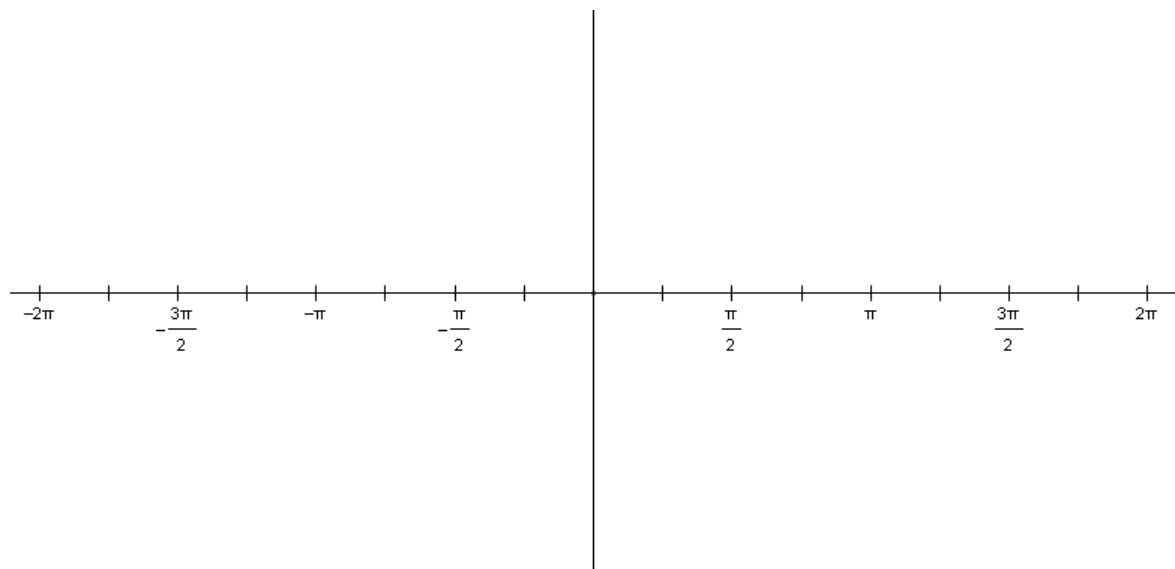

- Study the graph to answer the following questions:

Georgia Department of Education
Georgia Standards of Excellence Framework
GSE Pre-Calculus • Unit 1

- a. Does $y = \sin x$ appear to be a periodic function? If so, what is its period?
 - b. What is the domain and range?
 - c. What is the y-intercept?
 - d. Where do the x-intercepts occur?

 - e. What are the maximum values and where do they occur?

 - f. What is the minimum value and where does it occur?

 - g. How would your answers to questions d, e, and f change if your graph continued past 360° ?

 - h. What is the midline? What is the amplitude?

 - i. The **frequency** of a trigonometric function is the number of cycles the function completes in a given interval. The frequency is related to the period and is defined to be the reciprocal of the period. $y = \sin x$ completes one cycle in a distance of 2π units so in 1 unit it completes $\frac{1}{2\pi}$ units. (Think about it this way: $2\pi \approx 6.28$. For the sake of explaining about frequency, let's say that $2\pi \approx 6$. Then $y = \sin x$ completes one complete cycle in about 6 units; thus, it completes about $\frac{1}{6}$ of a cycle in one unit; the frequency is about $\frac{1}{6}$.)
NOTE: $\frac{1}{2\pi} \approx \frac{1}{6.28} \approx \frac{1}{6}$)
4. Use exact values from the unit circle to complete the following chart for $y = \cos x$ where x is a real number.

Georgia Department of Education
 Georgia Standards of Excellence Framework
GSE Pre-Calculus • Unit 1

x	$-\frac{7\pi}{4}$	$-\frac{3\pi}{2}$	$-\frac{5\pi}{4}$	$-\pi$	$-\frac{3\pi}{4}$	$-\frac{\pi}{2}$	$-\frac{\pi}{4}$	0	$\frac{\pi}{4}$	$\frac{\pi}{2}$	$\frac{3\pi}{4}$	π	$\frac{5\pi}{4}$	$\frac{3\pi}{2}$	$\frac{7\pi}{4}$	2π
$\cos x$																

5. Plot the data on the grid below.

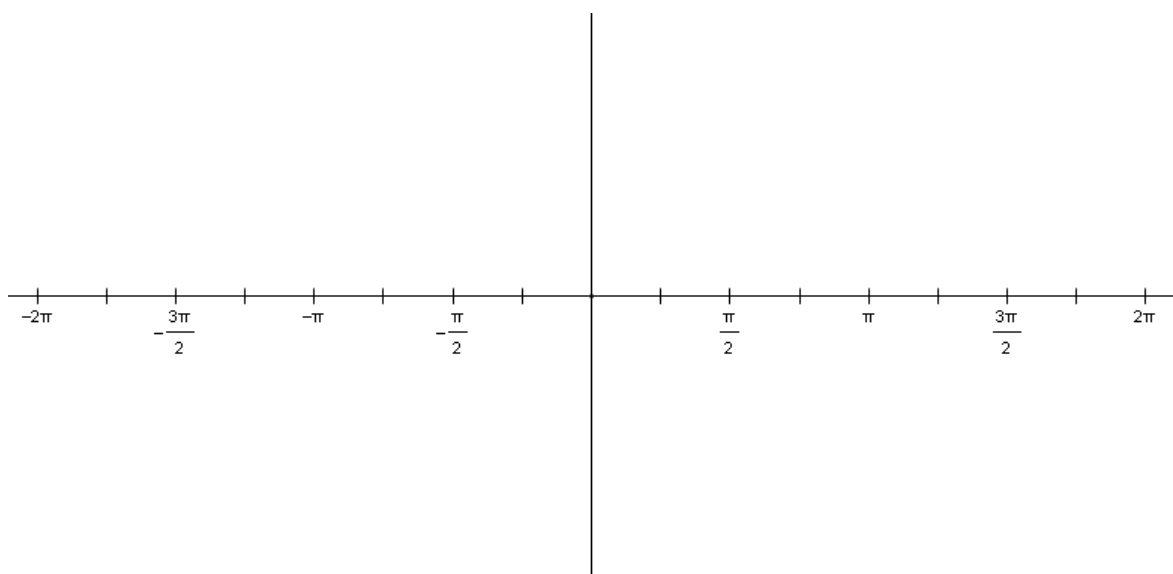

6. Study the graph of $y = \cos x$ to answer the following questions:

- a. What is the period?
- b. What is the domain and range?
- c. What is the y-intercept?
- d. Where do the x-intercepts occur?
- e. What is the maximum value and where does it occur?
- f. What is the minimum value and where does it occur?

Georgia Department of Education
Georgia Standards of Excellence Framework
GSE Pre-Calculus • Unit 1

- g. Picture your graph continuing past 2π . How would your answers to questions d, e, and f change?
 - h. Re-write your answers to d, e, and f so that you've included all possible values of x .
 - i. What is the midline? What is the amplitude?
7. Use your graphing calculator to graph $y = \sin x$. Check your mode to make sure you are using radians and make sure you have an appropriate window for your data. Sketch the graph of $y = \sin x$ below. Make sure you draw a smooth curve. How does this graph compare to your hand-drawn graph in problem 2?
8. Use your graphing calculator to graph $y = \cos x$. Check your mode to make sure you are using radians and make sure you have an appropriate window for your data. Use the grid below to draw an accurate graph of $\cos x$. Make sure you draw a smooth curve. How does this graph compare to your hand-drawn graph in problem 5?

Georgia Department of Education
Georgia Standards of Excellence Framework
GSE Pre-Calculus • Unit 1

9. Using your calculator, graph $y = \sin x$ and $y = \cos x$ on the same axis. How are they alike? How are they different?
10. Using what you have learned about the graphs of the sine and cosine functions, practice graphing the functions by hand. You should be able to quickly sketch the graphs of these functions, making sure to include zeroes, intercepts, maximums and minimums. Be sure to create a smooth curve!

A Better Mouse Trap (Spotlight Task)

Note: Because of the complexity of this task, it works better when (literally) given piece-by-piece to students. ALL of Q#1 is designed to be done as a whole-group introduction. Giving students that page and showing the video would start some great conversation. What if the wheels are two different sizes? How does the back end not end up in the front? After discussion of #1, hand out page 2, etc. Otherwise this task can feel overwhelming. However, at its conclusion, students should be able to explain not only HOW to graph a trigonometric equation with all of the bells and whistles, but also what each part means, and how it applies to real-world phenomena.

Suggested Lesson Outline, Option 1(3 days):

<i>Day 1</i>	<i>Day 2</i>	<i>Day 3</i>
<i>Open with Q1(whole group) Collab: Q2-5</i>	<i>Open with Q6 (whole group) Collab:Q7-11</i>	<i>Open with Q12 (partners, then whole group) Collab:Q13 Homework: Steamroller</i>

OR Suggested Lesson Outline, Option 2 (2 days):

<i>Day 1</i>	<i>Day 2</i>
<i>Open with Q1(whole group) Collab:Q2-5 Q6 Ticket Out the Door</i>	<i>Open with Q7 (whole group) Collab:Q7-Q13 Homework: Steamroller</i>

Mathematical Goals

- Model trigonometric phenomena including distance traveled, radians traversed, and height of a point on a circle in terms of the angle, in terms of time, and in terms of distance traveled.
- Write the equation of trigonometric situations.
- Realize that oscillating behavior of a graph does not necessarily represent a wave, but rather a repeating pattern
- Recognize the aspects of a trigonometric graph for the data that it represents in the real world situation.

Georgia Standards of Excellence

MGSE9-12.F.IF.7 Graph functions expressed algebraically and show key features of the graph both by hand and by using technology.

MGSE9-12.F.IF.7e Graph exponential and logarithmic functions, showing intercepts and end behavior, and trigonometric functions, showing period, midline, and amplitude.

Extend the domain of trigonometric functions using the unit circle

MGSE9-12.F.TF.1 Understand radian measure of an angle as the length of the arc on the unit circle subtended by the angle.

MGSE9-12.F.TF.2 Explain how the unit circle in the coordinate plane enables the extension of trigonometric functions to all real numbers, interpreted as radian measures of angles traversed counterclockwise around the unit circle.

Model periodic phenomena with trigonometric functions

MGSE9-12.F.TF.5 Choose trigonometric functions to model periodic phenomena with specified amplitude, frequency, and midline.

Standards for Mathematical Practice

- Make sense of problems and persevere in solving them.
- Model with mathematics.
- Reason abstractly and quantitatively.
- Construct viable arguments and critique the reasoning of others.
- Model with mathematics. Use appropriate tools strategically.
- Attend to precision.
- Look for and make use of structure.
- Look for and express regularity in repeated reasoning.

Introduction

In this task students explore a sine graph and its amplitude, period, vertical shifts, and horizontal (phase) shifts, affect the graph of the sine in the context of two differently-sized wheels attached to the same car and rolling at the same speed. Students will not only study these trigonometric phenomena, they will also explore how things like the angle achieved at a given speed is directly correlated with the time (since distance = rate x time). Using this fact and ratios such as $\frac{\text{distance traveled}(cm)}{2\pi r * \text{rotations}(cm)} = \frac{\text{Angle Location (in radians)}}{2\pi \text{ radians}}$, students will write the entire equation for where the sticker (star) is located in terms of first θ (angle location in radians), and then in terms of t (time in seconds).

Materials

- Task Copies
- Pencil
- Calculator in Radian Mode
- Way to show task

1. *Allow students to read the information about the Mouse Trap Race Car, and speculate as to the way that the wheels on the car will turn relative to one another.*

Questions to pose to students

1. *How do the wheels 'size on the Race Car relate to one another? (Back wheel is twice the size of the front wheel).*

Georgia Department of Education
Georgia Standards of Excellence Framework
GSE Pre-Calculus • Unit 1

2. *How fast across the ground will the back wheel go? What about the front wheel? (A: They are attached to the same car and therefore go the same speed).*
3. *Will the back wheel travel double the distance the front wheel travels, or vice versa? (A: Trick question...again, attached to the same car. They will travel the same distance unless the car falls apart.)*
4. *How do the circumferences of the two wheels compare to one another if the big radius is double the smaller one?*
2. *START of the super-quick three-scene task (watch/discuss/watch-not quite a “three act!”). Using their mobile devices, computers, or projected from your teacher work station, click or type the YouTube link found on #1. Go until you see the question, and then stop before watching the finale.*
3. *Q: OK, you saw the two carts...how did THEIR wheels compare to one another in terms of size? (A: The larger one was twice the size of the smaller one).*
4. *Q: How many times did the bigger wheel go around? (A: 3.5)*
5. *Q: How many times did the smaller wheel go around? (A: 7)*

SAY: The goal of this task is to see how two differently-sized wheels turn relative to one another when travelling the same distance, and also to take a look at the equations of the height of the sticker (the video shows a green one, and it's a star in this task) for each angle measure and time. We will discover and reinforce how a parent function is affected by changes in the data you have, and how that data affects the equations and graphs. We will also show how, if you know the speed of the car, and the angle of rotation, you can figure out what time that happened.

Directions: Read about the Mouse Trap Race Car, and answer the questions that follow.

A Better Mouse Trap



If you have time, this could be a fun sideline thing for students to do – build a mouse trap car, and study different aspects of the car such as rate of change, Hooke’s Law for Springs, and of course trigonometric movement of something (a sticker for instance) around the edge of the wheel over time.

Students would first read the introduction, and try to decide-if the center of the wheels is moving forward at 24 cm/s, does that mean that the rotation of the wheel is the same rate, too? Why? What about the distance each wheel traveled? Same or different?

A Mouse Trap Race Car is one that uses the energy found in the spring of a mouse trap to propel the “car” forward. The diagram below shows one design, which winds a ribbon around the rear axle of the car, and when the trap snaps, pulls the string, causing the car to GO!

Mickey made a Mouse Trap Race Car for a Mouse Trap Race Car Competition sponsored by PBS. His was made using two CD’s on the back as rear wheels, and a small toy car wheel (which is significantly smaller than the CD’s) on the front. Mickey used the Mouse Trap’s stored-spring energy to snap the trap and propel the car forward quickly to win the race.

(PBS Mouse Trap Race Car Details can be found at:

<http://www.pbs.org/saf/1208/teaching/teaching.htm>).

(Sample Mouse Trap Race Car can be seen here:

<http://www.youtube.com/watch?v=mVNFxIEMWvw>).

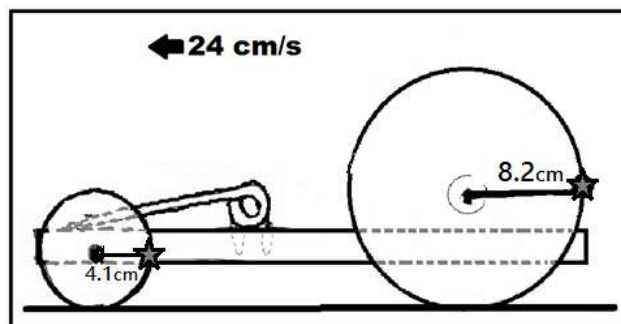

Mickey's front wheel has a radius of 4.1 cm, and the rear wheels have a radius of 8.2 cm. Mickey's car travels 24 centimeters per second. He is required by race rules to place a small round star sticker on the back of each of his wheels so that the movement of the sticker around the circumference of the wheel may be tracked by cameras.

1. **WHAT DO YOU THINK?** The center of both wheels are moving at 24 cm/s. Does that mean that the wheels rotate at the same speed also?

- a. *After discussion-I believe that, compared to one another, the two wheels will rotate in the following way and for the following reason(s):*

This part is still teacher-led. Have students guess at the answer to this, and justify why. Ask "Does anyone else disagree?" Get samples of both opinions.

BEGIN PART 1 of VIDEO (<http://youtu.be/PTE1V8scYV4>)

Notes: *Student take notes of what they see. CAREFUL to stop the video on the screen with the big green dot. You can rewind and replay it, letting them see it again, or pause the video.*

- b. *After watching part 1-I believe that, compared to one another, the two wheels will rotate in the following way and for the following reason(s):*

The comparative sizes of the wheels is going to be shown. It's clear that the smaller wheel is half the size of the larger one. Students see the track on which each wheel will roll. Ask students to discuss now, and also to justify why they think what they do or why they disagree with classmates.

BEGIN PART 2 of VIDEO.

Notes:

The students should watch the rest of the video. Note that the video isn't one of speed vs. time...it's distance vs. time. This adds an extra discussion-worthy dimension. It is worth mentioning so that they can see that it wasn't a RACE really, but two carts following the same path. The big question will be...after seeing the big wheel roll ..3.5 revolutions and the small one go 7 revolutions, what does that mean about how fast the green stickers on each wheel rotate? Does that answer whether or not the wheels rotate at the same SPEED?

Ask students to justify why or why not the video is sufficient to answer the question.

Some intuitive students might point out that on a Race Car, the two wheels would be attached to the same car, which logically implies that their rate, time, AND distance would be the same thing, which means that the question above (how fast are they turning) could be compared using the number of rotations you count. The video isn't the exact situation proposed, but it really tells students enough about how the two wheels behave to answer the question above with "no." The rotations aren't the same,

even if the distance traveled, rate of the center point moving forward, the time are.

After watching part 2-I believe that, compared to one another, the two wheels will rotate in the following way and for the following reason(s):

Student answers vary-hopefully they see that the small wheel rolled 7 times and the larger wheel rolled 3.5 times, and maybe speculated that the back wheel will roll half as fast as the smaller wheel.

2. LOCATION OF MICKEY’S STICKER:

Mickey placed a sticker on the back of each wheel so that he could track each wheel’s movement. Here, it appears the star is at four places... $\frac{\pi}{4}$, $\frac{3\pi}{4}$, $\frac{5\pi}{4}$, & $\frac{7\pi}{4}$. Explain how you can find the height of the star sticker at each of these angle measures, and show your work in the boxes provided. *“You all have some really interesting ideas about this...lets’ see if we can figure out what’s going on here.” Q#2 is designed to show the link between the height of the sticker and the angle of rotation by trigonometry. Do not give too much help here, let them arrive at the equations on their own. If students get stuck (they may have a tough time finding the link between the rotation and the vertical leg of a triangle formed within the circle), ask them, “Well, take a look at the pictures provided for you. What parts of the picture changes as the point rotates around the edge? What shapes do you see? What facts do you know about (circles) or (triangles)? How far above the ground is the horizontal diameter? How far is it from the top of the circle to the ground?”*

Angle of Rotation	$\frac{7\pi}{4}$ rad <i>(Sine is NEGATIVE in this quadrant)</i>	$\frac{5\pi}{4}$ rad <i>(Sine is NEGATIVE in this quadrant)</i>	$\frac{3\pi}{4}$ rad <i>(Sine is POSITIVE in this quadrant)</i>	$\frac{\pi}{4}$ rad <i>(Sine is POSITIVE in this quadrant)</i>
Height above Ground <i>*Note-the precision of the information originally presented was precise to the tenths. Therefore the precision of calculations within this problem is also</i>	$\sin\frac{7\pi}{4} = \frac{x}{8.2}$ $8.2 \sin\frac{7\pi}{4} = x$ $x \approx -5.8$ $8.2 + -5.8 \approx 2.4$	$\sin\frac{5\pi}{4} = \frac{x}{8.2}$ $8.2 \sin\frac{5\pi}{4} = x$ $x \approx -5.8$ $8.2 + -5.8 \approx 2.4$	$\sin\frac{3\pi}{4} = \frac{x}{8.2}$ $8.2 \sin\frac{3\pi}{4} = x$ $x \approx 5.9$ $8.2 + 5.9 \approx 14.0$	$\sin\frac{\pi}{4} = \frac{x}{8.2}$ $8.2 \sin\frac{\pi}{4} = x$ $x \approx 5.9$ $8.2 + 5.9 \approx 14.0$

Georgia Department of Education
 Georgia Standards of Excellence Framework
 GSE Pre-Calculus • Unit 1

<p>Height above Ground <i>*Note-the precision of the information originally presented was precise to the tenths. Therefore the precision of calculations within this problem is also tenths. The 14.0 was 13.99 originally, but rounded to the appropriate levels of precision yield 14.0. (Same for 7.0)</i></p>	$\sin\frac{7\pi}{4} = \frac{x}{4.1}$ $4.1\sin\frac{7\pi}{4} = x$ $x \approx -2.9 \text{ cm}$ $4.1 + -2.9 \approx 1.2$	$\sin\frac{5\pi}{4} = \frac{x}{4.1}$ $4.1\sin\frac{5\pi}{4} = x$ $x \approx -2.9 \text{ cm}$ $4.1 + -2.9 \approx 1.2$	$\sin\frac{3\pi}{4} = \frac{x}{8.2}$ $4.1\sin\frac{3\pi}{4} = x$ $x \approx 2.9 \text{ cm}$ $4.1 + 2.9 \approx 7.0$	$\sin\frac{\pi}{4} = \frac{x}{8.2}$ $4.1\sin\frac{\pi}{4} = x$ $x \approx 2.9 \text{ cm}$ $4.1 + 2.9 \approx 7.0$
---	---	---	---	---

3. **BIG VS. SMALL:** If the big wheel has rolled θ radians, how many radians has the small wheel rolled?
 2θ
4. **EQUATION:** Based on the four examples above, what is Mickey's equation $h(\theta)$, for the height of the star sticker at any given value of θ ? **Each time, you used the sine of the angle times the radius, and then added the radius in. The generic equation is $h(\theta) = r\sin(\theta) + r$ (cm) for the larger equation, and $h(\theta) = r\sin(2\theta) + r$ for the smaller equation.**

$h_{\text{rear}}(\theta) = \text{REAR TIRE'S STICKER HEIGHT}$	$h_{\text{front}}(\theta) = \text{FRONT TIRE'S STICKER HEIGHT}$
$h_{\text{rear}}(\theta) = h_{\text{rear}}(\theta) = 8.2\sin(\theta) + 8.2 \text{ cm}$	$h_{\text{front}}(\theta) = h_{\text{front}}(\theta) = 4.1\sin(2\theta) + 4.1 \text{ cm}$

5. **CIRCUMFERENCE:** What is the Circumference of each of Mickey's Tires??

REAR TIRES	FRONT TIRES
<i>Radius of the rear tires is 8.2 so the circumference is $16.4\pi \text{ cm}$. $\approx 51.5 \text{ cm}$</i>	<i>Radius of the rear tires is 4.1 so the circumference is $8.2\pi \text{ cm}$. $\approx 26.8 \text{ cm}$</i>

6.

Mickey graphed both equations above on the same set of axes, below. Minnie says this graph is misleading. Why is Minnie correct or incorrect? Minnie then graphs what she believes is the graph of the two on the right. Mickey says that she is wrong. Who is correct?

Mickey's Graph:
The Height of Both Wheels Above the Ground in Radians at any Given Time

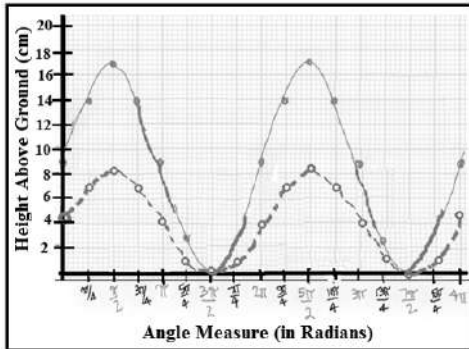

Minnie's Graph:
The Height of Both Wheels Above the Ground in Radians at any Given Time

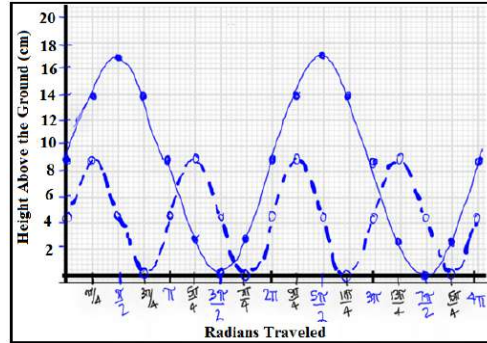

Minnie is correct. On Mickey's graph, the graphs of the two equations are correct for the equations themselves in that the graph is showing the correct heights for the given radian measures. The problem is that Mickey's graphs do not clearly show that the smaller wheel is turning twice as fast as the larger wheel. Because the smaller wheel is turning twice as fast, the local minimum value point $(\frac{3\pi}{2}, 0)$ on the smaller wheel's graph should actually be $(\frac{3\pi}{4}, 0)$. The period of the smaller graph should be π instead of 2π . Mickey graphed $h_{front}(\theta) = 4.1\sin(\theta) + 4.1$ cm, and should have graphed $h_{front}(\theta) = 4.1\sin(2\theta) + 4.1$. Minnie's graph clearly shows that the smaller wheel is turning twice as fast. She graphed $h_{front}(\theta) = 4.1\sin(2\theta) + 4.1$ cm

7. **“IN TERMS OF”**: Minnie wants to show Mickey that the equations could be more easily graphed if, instead of radian measures, the independent variable was how far the two wheels had traveled, since both wheels would have traveled the same distance at the same time. So instead of $h_{rear}(\theta)$ and $h_{front}(\theta)$ she wants to create $h_{rear}(d)$ and $h_{front}(d)$ where d represents distance, in feet.

$$\frac{2\theta_{front} \text{ (rad)}}{2\pi \text{ (rad)}} = \frac{d \text{ (cm)}}{2\pi(4.1)\text{(cm)}}$$

and

$$\frac{\theta_{rear} \text{ (rad)}}{2\pi \text{ (rad)}} = \frac{d \text{ (cm)}}{2\pi(8.2)\text{(cm)}}$$

- a. These proportions are based on a formula that Minnie learned in Analytic Geometry class. What formula is it, and why does it work?

This formula is arclength, and it is a proportion that compares the number of degrees/radians traveled around a circle over $360^\circ/2\pi \text{ rad}$ (part to whole) to arclength over circumference (also part to whole). It pertains because the distance traveled by the wheels IS the arclength. Cars use the number of rotations of the axle of a car to determine distance traveled (arclength of tire) on your car’s odometer. This particular idea could lead to some interesting follow-up questions, such as, “What do you think would happen to a car’s odometer reading if someone were to outfit a car with wheels that are much smaller in radius than the type that was factory pre-installed on the car? What about if the wheel is much larger? (Answer: smaller wheels increase your odometer reading and the chances of getting stuck or scratched on a speed bump! Larger wheels keep your odometer reading slightly lower because the odometer is calibrated to count the rotations of the specific wheels size and convert it to arclength \rightarrow mileage. Before you go get 24’s on your car, there is a downside: Speedometers are also calibrated to wheel size, which means your instrument panel will show that you are traveling much slower than you are actually travelling, increasing your chances of getting a ticket!

Rearrange the proportions found above and use them to create the equations Minnie wants to write so θ is replaced by distance in centimeters.

In order to create an equation in terms of d , you have to eliminate θ by isolating (solving) for θ . So the

$$\theta_{front} = \frac{2\pi d}{2\pi * 2 * (4.1)} = \frac{d}{2 * (4.1)}; \rightarrow \rightarrow \rightarrow \rightarrow \rightarrow \rightarrow h_{front}(d) = 4.1 \sin\left(2 * \frac{d}{2 * (4.1)}\right) + 4.1 \text{ cm}$$

$$\theta_{rear} = \frac{2\pi d}{2\pi(8.2)} = \frac{d}{(8.2)} \rightarrow \rightarrow \rightarrow \rightarrow \rightarrow \rightarrow h_{rear}(d) = 8.2 \sin\left(\frac{d}{(8.2)}\right) + 8.2 \text{ cm}$$

8. **“IN TERMS OF” TIME**: Not to be outdone, Mickey wants to show he can write Minnie’s equation in terms of time, in seconds. He knows that $distance = rate * time$. He wants to use Minnie’s distance, above, and he knows that the car is moving 24 cm/second. Rewrite Minnie’s equations in terms of time, t , in seconds.

*Since $d = r * t$ you can substitute the known rate (24 cm/second)...that would give you $d = (24)(t)$.*

Georgia Department of Education
 Georgia Standards of Excellence Framework
 GSE Pre-Calculus • Unit 1

$$h_{front}(t) = 4.1 \sin\left(2 * \frac{24t}{2 * (4.1)}\right) + 4.1 \text{ cm}$$

$$h_{rear}(t) = 8.2 \sin\left(\frac{24t}{(8.2)}\right) + 8.2 \text{ cm}$$

9. **MODELING:** Use the scales provided to model the height of the rear wheel for each rotation so that everything below the “Rear Wheel Rotations” lines up correctly. For instance, for part b, how many front wheel rotations happen when the rear wheel rotations are on the “1” already listed there? *Note: You will graph the height of the wheels over time in part A, and you are only asked to draw corresponding hash marks and label the number lines on parts B-E*

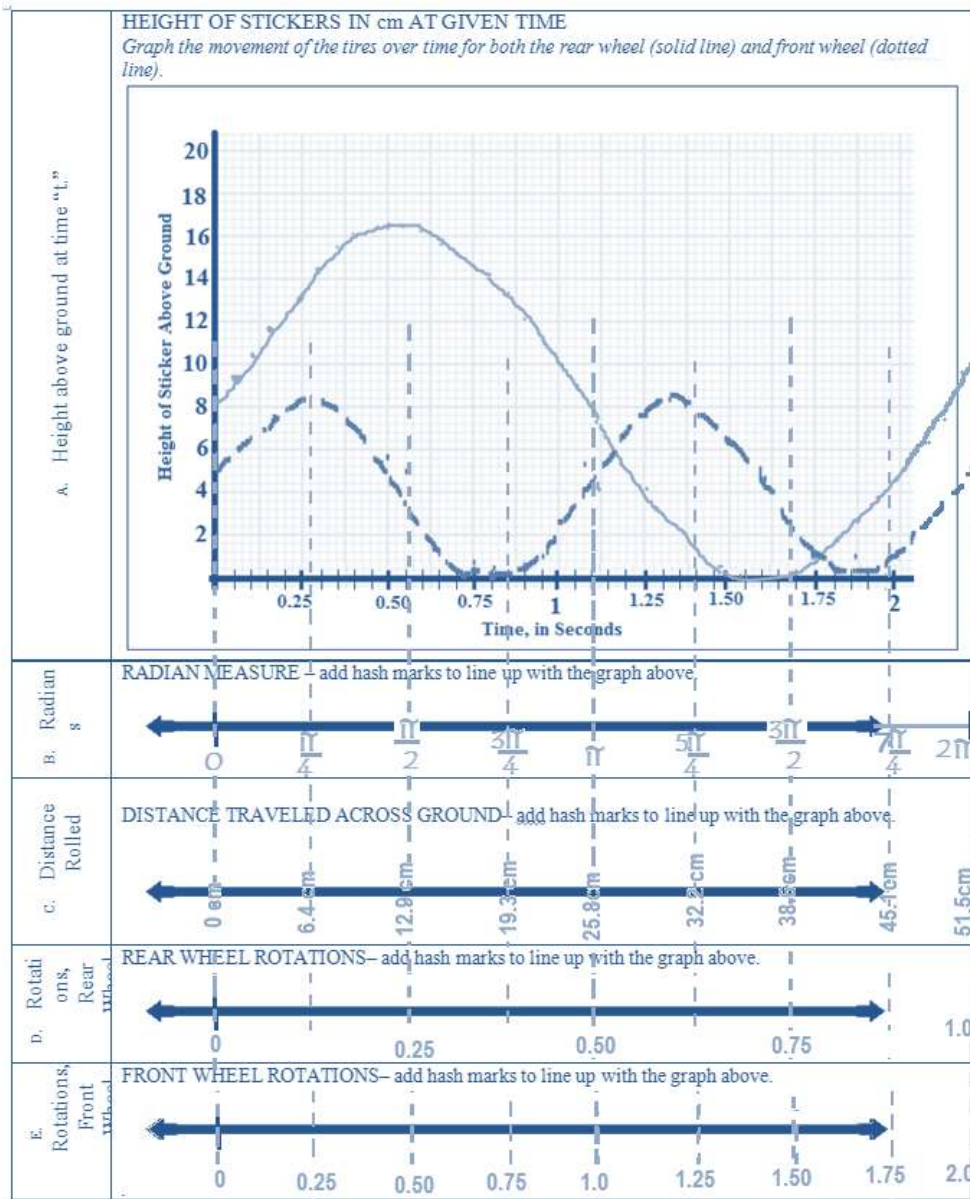

Georgia Department of Education
 Georgia Standards of Excellence Framework
 GSE Pre-Calculus • Unit 1

10a. **SPEED part 1** - : How fast does the center point of each tire travel across the ground in cm/s?

<i>LARGE (REAR) TIRE CENTER POINT SPEED</i>	<i>SMALL (FRONT) TIRE CENTER POINT SPEED</i>
<i>24 cm/s</i>	<i>24 cm/s</i>

10b. **SPEED part 2** - : How many rotations per second does each tire make?

<i>LARGE (REAR) TIRE RPS</i>	<i>SMALL (FRONT) TIRE RPS</i>
$\frac{24 \text{ cm}}{1 \text{ second}} \times \frac{1 \text{ rotation}}{2 * (8.2) * \pi \text{ cm}}$ $\approx 0.47 \text{ rotations / sec}$	$\frac{24 \text{ cm}}{1 \text{ second}} \times \frac{1 \text{ rotation}}{2 * (4.1) * \pi \text{ cm}}$ $\approx 0.93 \text{ rotations / sec}$

10c. **SMALL vs. LARGE**: What is the relationship between rotations of the small tire vs. the large tire?

The small tire's rotations per second are double the large tire's rotations per second.

Discussion Questions:

11. What would the equations (for both the rear and the front wheel) for the height of the stickers with respect to time in seconds if the stickers both started on the GROUND?

Note: “ $\theta + \frac{3\pi}{2}$ ” and “ $2\theta + \frac{3\pi}{2}$ ” is used below for the angle, but some may prefer “ $\theta - \frac{\pi}{2}$,” and “ $2\theta - \frac{\pi}{2}$,” and those would work, as well. If there are students who are conflicted, have one group use $+\frac{3\pi}{2}$ and another one use $-\frac{\pi}{2}$. Then ask them to interpret what this means, in terms of the wheel of a racecar. If you plan to start with the sticker on the bottom of the wheel, does it matter if (assuming your sticker is at 0° to start) you roll the car forward 270° vs. roll the car backward 90° ?

Georgia Department of Education
 Georgia Standards of Excellence Framework
 GSE Pre-Calculus • Unit 1

REAR TIRE	FRONT TIRE
<p><i>IN TERMS OF θ:</i></p> $h_{rear}(\theta) = 8.2 \sin\left(\theta + \frac{3\pi}{2}\right) + 8.2 \text{ cm}$ <p><i>IN TERMS OF DISTANCE TRAVELED:</i></p> $\frac{\theta_{rear} \text{ (rad)}}{2\pi \text{ (rad)}} = \frac{d \text{ (cm)}}{2\pi(8.2)(\text{cm})}$ $\theta_{rear} = \frac{2\pi d}{2\pi(8.2)} = \frac{d}{(8.2)}$ $h_{rear}(\theta) = 8.2 \sin\left(\frac{d}{8.2} + \frac{3\pi}{2}\right) + 8.2 \text{ cm}$ <p><i>IN TERMS OF TIME:</i></p> <p>Distance = rate*time.... $d=24t$ so</p> $h_{rear}(\theta) = 8.2 \sin\left(\frac{24t}{8.2} + \frac{3\pi}{2}\right) + 8.2 \text{ cm}$	<p><i>IN TERMS OF θ:</i></p> $h_{front}(\theta) = 4.1 \sin\left(2\theta + \frac{3\pi}{2}\right) + 4.1 \text{ cm}$ <p><i>IN TERMS OF DISTANCE TRAVELED:</i></p> $\frac{2\theta_{front} \text{ (rad)}}{2\pi \text{ (rad)}} = \frac{d \text{ (cm)}}{2\pi * 2 * (4.1)(\text{cm})}$ $\theta_{front} = \frac{2\pi d}{2\pi * 2 * (4.1)} = \frac{d}{2}$ $h_{front}(\theta) = 4.1 \sin\left(2 * \frac{d}{8.2} + \frac{3\pi}{2}\right) + 4.1 \text{ cm}$ <p><i>IN TERMS OF TIME:</i></p> <p>Distance = rate*time.... $d=24t$ so</p> $h_{front}(\theta) = 4.1 \sin\left(2 * \frac{24t}{8.2} + \frac{3\pi}{2}\right) + 4.1 \text{ cm}$

12. For the equations you found in #11, what does each of the following terms actually MEAN for the wheels on this Mouse Trap Race Car? Amplitude is done for you so that you can see how to answer each of these.

Term	Explain this relative to the equation AND the cars. Also-how would changing this number change the graph, and how would changing this number change the appearance of the car's wheels?
Amplitude	<p>EXAMPLE: You find the number that affects amplitude on the outside of the trig function. For example, in $f(\theta) = a \sin(b\theta - c) + d$, amplitude is "a," because it is multiplying the trigonometric function. The multiplier multiplies the range, and stretches the graph vertically. It goes "a" many times higher and lower. Amplitude in this situation had to do with how big the wheel was. The bigger the wheel, the bigger the amplitude because $a \sin(x)$ was used to find the height. HAD IT BEEN NEGATIVE, that would mean the wheel was traveling left to right instead of right to left, and graphically it would be reflected across the x axis.</p>
Period	<p>You find the period multiplying the variable θ. In this equation, "b" affects the period. Basically, that multiplier inside the parentheses tells you how many times within a normal $[0, 2\pi]$ period the function will cycle through...but the PERIOD tells you the width of one iteration. If the function cycles "b" times in a normal period and a period is 2π, you can find a function's period using $\frac{2\pi}{b}$.</p> <p>In this situation, the small wheel rolled twice as fast (this is the frequency). Its multiplier was two but its period was halved.</p>

Frequency	<i>The frequency IS the multiplier of x. The frequency and the period are inversely linked. When you double the frequency, you half the period. If the frequency triples, then the period is only a third. Similarly, if the frequency halves, the period doubles. In terms of the wheels, if the smaller wheels' rotations double in frequency compared to the larger wheels, and it takes half the ground distance and half the time to make a full rotation.</i>
Vertical Shift	<i>An amount added or subtracted from the entire function. (d, above) This shifts the function up and down. This was represented by the fact that the wheel was up from its midline and you always had to add or subtract the lower radius.</i>
Horizontal Phase Shift	<i>(This is c above). When the function does not start at the normal position (zero), but you are calculating the radians traversed rather than or in addition to position, the x value gets adjusted so that the calculations are done on the correct place on the unit circle. When the "sticker" started on the ground, that was an extra (3π/2) (or π/2 less) from the starting point.</i>
Midline	<i>The midline is the imaginary horizontal line in a trigonometry graph. It is shifted up or down by the vertical shift. In this situation, it represents the fact that the wheel never went underground-it is the axis of rotation.</i>

13. So what is the equation of the height of a sticker with respect to time if the sticker of a wheel with a radius of 10m on which the sticker starts at the bottom but that moves left to right (clockwise), and the center of the wheel moves forward at a rate of 30 m/s, and what is the equation of the wheel with all the same attributes, except the wheel is 5 times larger?

<p><i>IN TERMS OF θ:</i></p> $h_{small}(\theta) = 10 \sin\left(\frac{3\pi}{2} - 5\theta\right) + 10 \text{ cm}$ <p><i>IN TERMS OF DISTANCE TRAVELED:</i></p> $\frac{5\theta_{small} \text{ (rad)}}{2\pi \text{ (rad)}} = \frac{d \text{ (cm)}}{2\pi(10)(cm)}$ $\theta_{small} = \frac{2\pi d}{2\pi * 5 * (10)} = \frac{d}{(50)}$ $h_{small}(\theta) = 10 \sin\left(\frac{3\pi}{2} - 5\left(\frac{d}{(50)}\right)\right) + 10 \text{ cm}$ <p><i>IN TERMS OF TIME:</i></p> <p><i>Distance = rate*time.... d=30t so</i></p> $h_{small}(\theta) = 10 \sin\left(\frac{3\pi}{2} - 5\left(\frac{30t}{(50)}\right)\right) + 10 \text{ cm}$	<p><i>IN TERMS OF θ:</i></p> $h_{larger}(\theta) = 50 \sin\left(\frac{3\pi}{2} - \theta\right) + 50 \text{ cm}$ <p><i>IN TERMS OF DISTANCE TRAVELED:</i></p> $\frac{\theta_{larger} \text{ (rad)}}{2\pi \text{ (rad)}} = \frac{d \text{ (cm)}}{2\pi(50)(cm)}$ $\theta_{larger} = \frac{2\pi d}{2\pi(50)} = \frac{d}{(50)}$ $h_{larger}(\theta) = 50 \sin\left(\frac{3\pi}{2} - \left(\frac{d}{(50)}\right)\right) + 50 \text{ cm}$ <p><i>IN TERMS OF TIME:</i></p> <p><i>Distance = rate*time.... d=30t so</i></p> $h_{larger}(\theta) = 50 \sin\left(\frac{3\pi}{2} - \left(\frac{30t}{(50)}\right)\right) + 50 \text{ cm}$
--	--

STEAMROLLER WITH STICKERS FOLLOW-UP

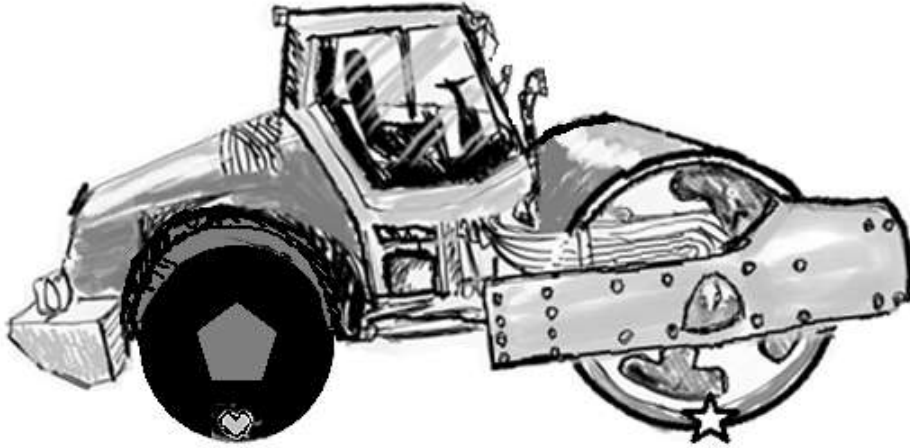

Junior has a toy steamroller and a little sister Trudy who loves stickers. She put a heart sticker on the bottom of the steamroller's rear wheel, and a star sticker on the front of the roller cylinder, which acts as a front wheel. The toy steamroller is drawn to scale above. Junior has allowed you to borrow his steamroller. You are in the hallway at school and you put the steamroller on the ground to roll to Trudy, who is exactly 10 feet away. You place the steamroller on the ground, with both of the stickers on the underside of their wheels. Suppose you push this steam roller toy down a 10-foot hallway at a steady rate of 2.4 feet per second to Trudy.

Let: R : = a function which defines the height of the heart sticker on the rear wheel.

F : = a function which defines the height of the star sticker on the front cylinder (wheel).

Answer the following:

1. How long will it be before the steamroller reaches the end of the hall? $4\frac{1}{6}$
2. Measure the wheels with a ruler and find the equations for
♥ $R(\theta)$ in radians, $R(d)$ in length, and $R(t)$ in seconds.
 $F(\theta)$ in radians, $F(d)$ in length, and $F(t)$ in seconds.
3. Either by hand or using technology, create a graph of both equations on the same axes which show the heights of the stickers at given times for a minimum of two iterations each.
4. Highlight the graph and write the inequalities that show the times that you can see both stickers at the same time if you are standing behind the toy as you push it toward Trudy, and you are able to see from

Georgia Department of Education
Georgia Standards of Excellence Framework
GSE Pre-Calculus • Unit 1

the very bottom of the wheel, the point where the sticker started out, all the way to the top of the wheel before you lose sight of the sticker again.

IN METRIC MILLIMETERS (much easier numbers to work with)

The Rear Wheel has a diameter of roughly 26 mm → radius = 13mm

The Front Wheel has a diameter of roughly 40mm → radius = 20mm

Converting the speed of the steamroller from feet per second to mm per second:

$$\frac{2.4 \text{ feet}}{1 \text{ second}} \times \frac{12 \text{ inches}}{1 \text{ foot}} \times \frac{2.54 \text{ cm}}{1 \text{ inch}} \times \frac{10 \text{ mm}}{1 \text{ cm}} \approx 731.52 \text{ mm / second}$$

Converting the length of the hallway to mm:

$$10 \text{ feet} \times \frac{12 \text{ inches}}{1 \text{ foot}} \times \frac{2.54 \text{ cm}}{1 \text{ inch}} \times \frac{10 \text{ mm}}{1 \text{ cm}} \approx 3048 \text{ mm in the hallway.}$$

The ratio of the larger wheel to the smaller one is $\frac{20}{13}$, which is the frequency of the smaller wheel

$$R(\theta) = 13 + 13 \sin\left(\frac{20}{13}\theta + \frac{3\pi}{2}\right)$$

$$F(\theta) = 20 + 20 \sin\left(\theta + \frac{3\pi}{2}\right)$$

$$R(d) = 13 + 13 \sin\left(\frac{20}{13}\left(\frac{d}{20}\right) + \frac{3\pi}{2}\right)$$

$$F(d) = 20 + 20 \sin\left(\left(\frac{d}{20}\right) + \frac{3\pi}{2}\right)$$

$$R(t) = 13 + 13 \sin\left(\frac{20}{13}\left(\frac{731.5t}{20}\right) + \frac{3\pi}{2}\right)$$

$$F(t) = 20 + 20 \sin\left(\left(\frac{731.5t}{20}\right) + \frac{3\pi}{2}\right)$$

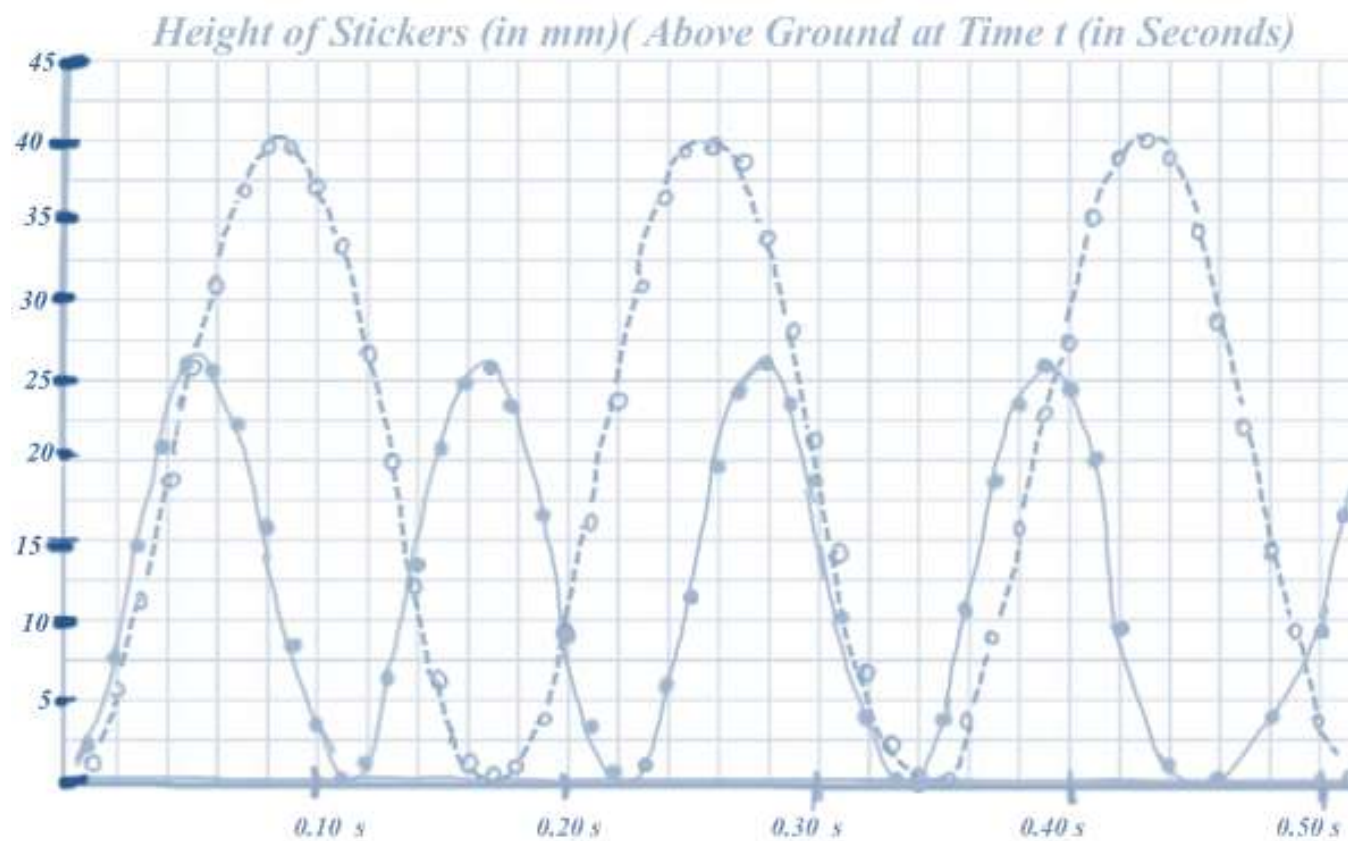

Georgia Department of Education
 Georgia Standards of Excellence Framework
 GSE Pre-Calculus • Unit 1

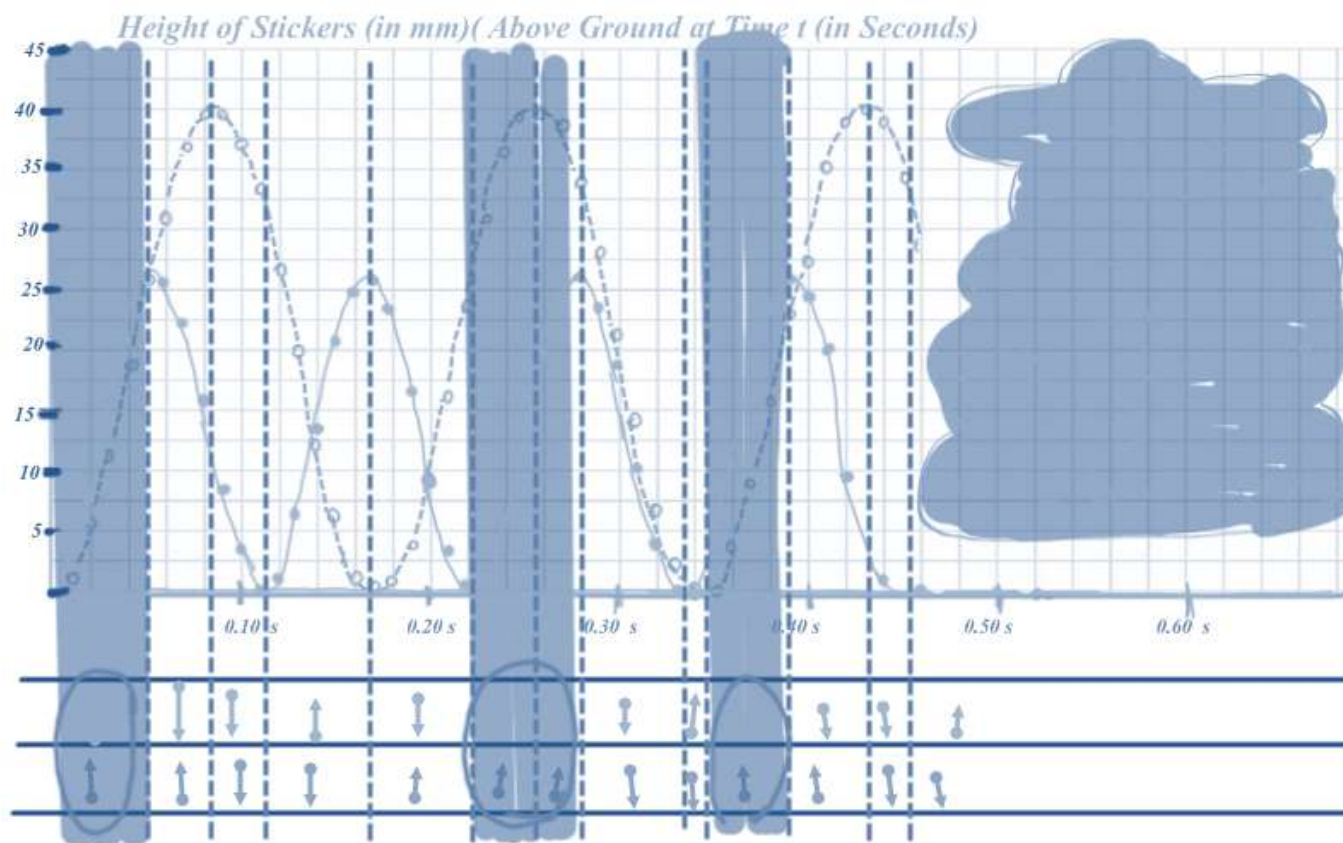

This exercise is one that will show why the equation IN TERMS OF TIME is useful when nice, even numbers aren't present from the beginning. Perhaps the most important Standard for Mathematical Practice they will grapple with in this graph is how to set up the axes and which units to use. They have to really play with the numbers and maybe try to graph this thing on their calculator before they will recognize that the wheels are spinning much faster than once per second, in fact, the changes needed to construct a graph correctly happen much faster than once per TENTH of a second. Therefore the x-axes must be divided in a way that incrementally gives will allow us to see the movement of the graph. Use this graph (above) to answer follow-up questions (copy it to SMART board and let students highlight areas where both graphs are increasing → you can see the stickers, show where both stickers are on the top of the wheel, show where the entire cycle starts back at the beginning (i.e. when are both stickers back on the ground where they both started?), etc. The answers to these questions are on the next graph.

Georgia Department of Education
 Georgia Standards of Excellence Framework
 GSE Pre-Calculus • Unit 1

IN STANDARD INCHES (get ready for fractions / decimals)

The Rear Wheel has a diameter of roughly 26 mm → radius = $1\frac{1}{16}$ inch

The Front Wheel has a diameter of roughly 40mm → radius = $1\frac{9}{16}$ inch

Converting the speed of the steamroller from feet per second to inches per second:

$$\frac{2.4 \text{ feet}}{1 \text{ second}} \times \frac{12 \text{ inches}}{1 \text{ foot}} = 28.8 \text{ inches / second}$$

Converting the length of the hallway to inches:

$$10 \text{ feet} \times \frac{12 \text{ inches}}{1 \text{ foot}} = 120 \text{ inches in the hallway.}$$

The ratio of the larger wheel to the smaller one is $\frac{1\frac{9}{16}}{1\frac{1}{16}} = \frac{25}{16} \div \frac{16}{17} \approx 1.47$, which is the frequency of the smaller wheel

$$R(\theta) = 1.0625 + 1.0625 \sin\left(1.47\theta + \frac{3\pi}{2}\right)$$

$$F(\theta) = 1.5625 + 1.5625 \sin\left(\theta + \frac{3\pi}{2}\right)$$

$$R(d) = 1.0625 + 1.0625 \sin\left(1.47\left(\frac{d}{1.561875}\right) + \frac{3\pi}{2}\right)$$

$$F(d) = 1.5625 + 1.5625 \sin\left(\left(\frac{d}{1.5625}\right) + \frac{3\pi}{2}\right)$$

$$R(t) = 1.0625 + 1.0625 \sin\left(1.47\left(\frac{28.8t}{1.561875}\right) + \frac{3\pi}{2}\right)$$

$$F(t) = 1.5625 + 1.5625 \sin\left(\left(\frac{28.8t}{1.5625}\right) + \frac{3\pi}{2}\right)$$

Height of Stickers (In inches) above the ground at Time “t”, in seconds.



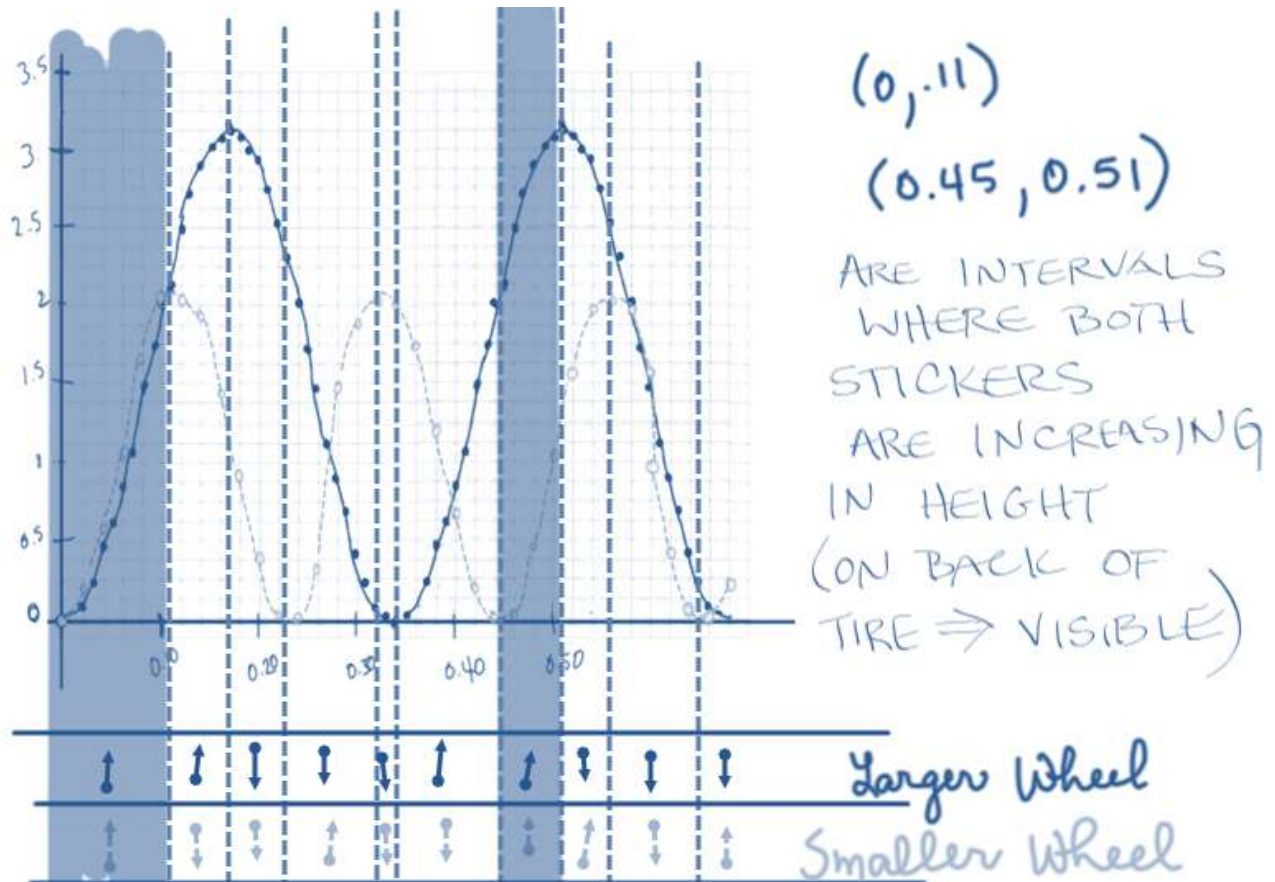

Interestingly, although the graphs in metrics vs. the graphs in standard line up perfectly if you place one on top of another, it is clear that in 0.5 seconds, metrics shows four tire rotations while standard accounts for only three. A discussion about precision may be warranted here – which is more precise? Which opens the door to greater margin of error? Does this matter?

BONUS QUESTIONS TO THROW OUT: HOW MUCH TIME DOES IT TAKE FOR THE STEAM ROLLER TO GET TO TRUDY? HOW MANY ROTATIONS OF THE FRONT AND BACK TIRES HAPPEN BETWEEN YOU AND TRUDY?

At this point you should also be able to throw out any sine equation...and students can describe what it models and how the graphs compare.

A Better Mouse Trap (Spotlight Task)

Mathematical Goals

- Model trigonometric phenomena including distance traveled, radians traversed, and height of a point on a circle in terms of the angle, in terms of time, and in terms of distance traveled.
- Write the equation of trigonometric situations.
- Realize that oscillating behavior of a graph does not necessarily represent a wave, but rather a repeating pattern
- Recognize the aspects of a trigonometric graph for the data that it represents in the real world situation.

Georgia Standards of Excellence

MGSE9-12.F.IF.7 Graph functions expressed algebraically and show key features of the graph both by hand and by using technology.

MGSE9-12.F.IF.7e Graph ~~exponential and logarithmic functions, showing intercepts and end behavior, and~~ trigonometric functions, showing period, midline, and amplitude.

Extend the domain of trigonometric functions using the unit circle

MGSE9-12.F.TF.1 Understand radian measure of an angle as the length of the arc on the unit circle subtended by the angle.

MGSE9-12.F.TF.2 Explain how the unit circle in the coordinate plane enables the extension of trigonometric functions to all real numbers, interpreted as radian measures of angles traversed counterclockwise around the unit circle.

Model periodic phenomena with trigonometric functions

MGSE9-12.F.TF.5 Choose trigonometric functions to model periodic phenomena with specified amplitude, frequency, and midline.

Standards for Mathematical Practice

- Make sense of problems and persevere in solving them.
- Model with mathematics.
- Reason abstractly and quantitatively.
- Construct viable arguments and critique the reasoning of others.
- Model with mathematics. Use appropriate tools strategically.
- Attend to precision.
- Look for and make use of structure.
- Look for and express regularity in repeated reasoning.

Introduction

In this task students explore a sine graph and its amplitude, period, vertical shifts, and horizontal (phase) shifts, affect the graph of the sine in the context of two differently-sized wheels attached to the same car and rolling at the same speed. Students will not only study these trigonometric phenomena, they will also explore how things like the angle achieved at a given speed is directly correlated with the time (since distance = rate x time). Using this fact and ratios such as

Georgia Department of Education
Georgia Standards of Excellence Framework
GSE Pre-Calculus • Unit 1

$\frac{\text{distance traveled}(cm)}{2\pi r * \text{rotations}(cm)} = \frac{\text{Angle Location (in radians)}}{2\pi \text{ radians}}$, students will write the entire equation for where the sticker (star) is located in terms of first θ (angle location in radians) , and then in terms of t (time in seconds).

Materials

- Task Copies Pencil Calculator in Radian Mode Way to show video

Directions: Read about the Mouse Trap Race Car, and answer the questions that follow.

A Better Mouse Trap

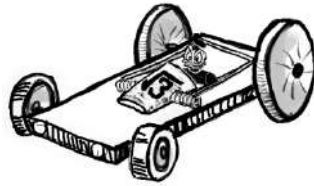

A Mouse Trap Race Car is one that uses the energy found in the spring of a mouse trap to propel the “car” forward. The diagram below shows one design, which winds a ribbon around the rear axle of the car, and when the trap snaps, pulls the string, causing the car to GO! Mickey made a Mouse Trap Race Car for a Mouse Trap Race Car Competition sponsored by PBS. His was made using two CD’s on the back as rear wheels, and a small toy car wheel (which is significantly smaller than the CD’s) on the front. Mickey used the Mouse Trap’s stored-spring energy to snap the trap and propel the car forward quickly to win the race.

(PBS Mouse Trap Race Car Details can be found at:

<http://www.pbs.org/saf/1208/teaching/teaching.htm>).

(Sample Mouse Trap Race Car can be seen here:

<http://www.youtube.com/watch?v=mVNFxIEMWvw>).

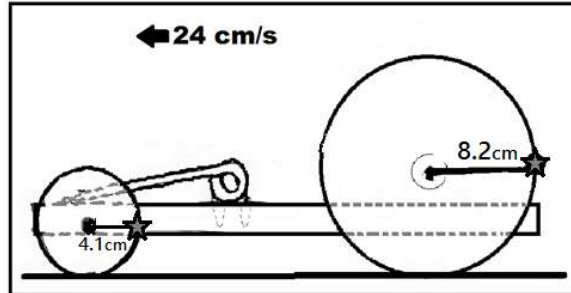

Mickey’s front wheel has a radius of 4.1 cm, and the rear wheels have a radius of 8.2 cm. Mickey’s car travels 24 centimeters per second. He is required by race rules to place a small round star sticker on the back of each of his wheels so that the movement of the sticker around the circumference of the wheel may be tracked by cameras.

1. **WHAT DO YOU THINK?** The center of both wheels are moving at 24 cm/s. Does that mean that the wheels rotate at the same speed also?
 - a. *After discussion-I believe that, compared to one another, the two wheels will rotate in the following way and for the following reason(s):*

BEGIN PART 1 of VIDEO (<http://youtu.be/PTE1V8scYV4>)

Notes:

- b. *After watching part 1-I believe that, compared to one another, the two wheels will rotate*

Georgia Department of Education
Georgia Standards of Excellence Framework
GSE Pre-Calculus • Unit 1

in the following way and for the following reason(s):

BEGIN PART 2 of VIDEO.

- c. After watching part 2-I believe that, compared to one another, the two wheels will rotate in the following way and for the following reason(s)*

2. LOCATION OF MICKEY'S STICKER:

Mickey placed a sticker on the back of each wheel so that he could track each wheel's movement. Here, it appears the star is at four places... $\frac{\pi}{4}$, $\frac{3\pi}{4}$, $\frac{5\pi}{4}$, & $\frac{7\pi}{4}$. Explain how you can find the height of the star sticker at each of these angle measures, and show your work in the boxes provided.

Angle of Rotation	$\frac{7\pi}{4}$ rad	$\frac{5\pi}{4}$ rad	$\frac{3\pi}{4}$ rad	$\frac{\pi}{4}$ rad
Height above Ground				

3. BIG VS. SMALL: If the big wheel has rolled θ radians, how many radians has the small wheel rolled?

Georgia Department of Education
 Georgia Standards of Excellence Framework
GSE Pre-Calculus • Unit 1

4. **EQUATION:** Based on the four examples above, what is Mickey’s equation $h(\theta)$, for the height of the star sticker at any given value of θ ?

$h_{\text{rear}}(\theta) = \text{REAR TIRE'S STICKER HEIGHT}$	$h_{\text{front}}(\theta) = \text{FRONT TIRE'S STICKER HEIGHT}$
$h_{\text{rear}}(\theta)$	$h_{\text{front}}(\theta)$

5. **CIRCUMFERENCE:** What is the Circumference of each of Mickey’s Tires??

REAR TIRES	FRONT TIRES

6. WHO IS RIGHT?

Mickey graphed both equations above on the same set of axes, below. Minnie says this graph is misleading. Why is Minnie correct or incorrect? Minnie then graphs what she believes is the graph of the two on the right. Mickey says that she is wrong. Who is correct?

Mickey's Graph:

The Height of Both Wheels Above the Ground in Radians at any Given Time

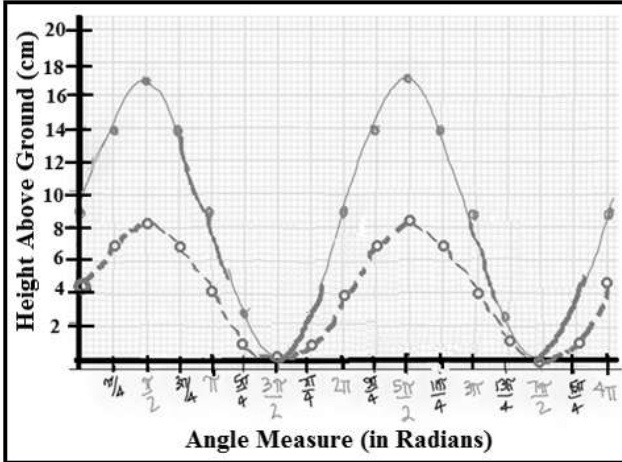

Minnie's Graph:

The Height of Both Wheels Above the Ground in Radians at any Given Time

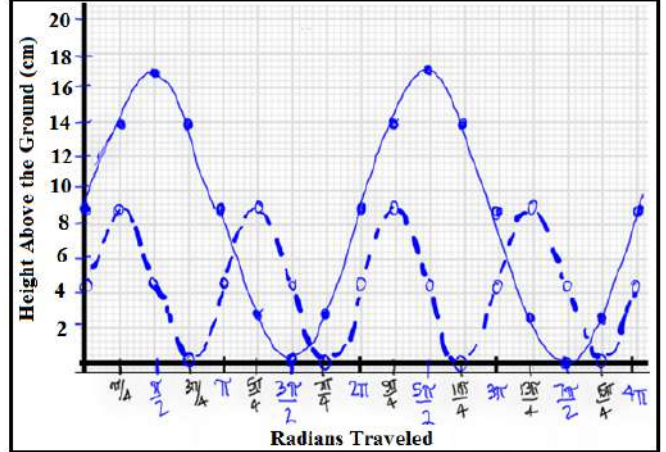

I believe that _____ is right, because:

7. **“IN TERMS OF”**: Minnie wants to show Mickey that the equations could be more easily graphed if, instead of radian measures, the independent variable was how far the two wheels had traveled, since both

Georgia Department of Education
 Georgia Standards of Excellence Framework
GSE Pre-Calculus • Unit 1

wheels would have traveled the same distance at the same time. So instead of $h_{rear}(\theta)$ and $h_{front}(\theta)$ she wants to create $h_{rear}(d)$ and $h_{front}(d)$ where d represents distance, in feet.

and

$$\frac{2\theta_{front} \text{ (rad)}}{2\pi \text{ (rad)}} = \frac{d \text{ (cm)}}{2\pi(4.1)\text{(cm)}}$$

and

$$\frac{\theta_{rear} \text{ (rad)}}{2\pi \text{ (rad)}} = \frac{d \text{ (cm)}}{2\pi(8.2)\text{(cm)}}$$

- a. These proportions are based on a formula that Minnie learned in Analytic Geometry class. What formula is it, and why does it work?

- b. Rearrange the proportions found above and use them to create the equations Minnie wants to write so that θ is replaced by distance in centimeters.

8. **“IN TERMS OF” TIME:** Not to be outdone, Mickey wants to show that he can write Minnie’s equation in terms of time, in seconds. He knows that $distance = rate * time$. He wants to use Minnie’s distance, above, and he knows that the car is moving 24 cm/second. Rewrite Minnie’s equations in terms of time, t , in seconds.

Georgia Department of Education
 Georgia Standards of Excellence Framework
GSE Pre-Calculus • Unit 1

9. **MODELING:** Use the scales provided to model the height of the rear wheel for each rotation so that everything below the “Rear Wheel Rotations” lines up correctly. For instance, for part b, how many front wheel rotations happen when the rear wheel rotations are on the “1” already listed there? *Note: You will graph the height of the wheels over time in part A, and you are only asked to draw corresponding hash marks and label the number lines on parts B-E.*

Height above	<p>HEIGHT OF STICKERS IN cm AT GIVEN TIME <i>Graph the movement of the tires over time for both the rear wheel (solid line) and front wheel (dotted line).</i></p>
A. Radians	<p>RADIAN MEASURE – add hash marks to line up with the graph above.</p> <p style="text-align: center;">←—————→</p>
B. Distance Rolled	<p>DISTANCE TRAVELED ACROSS GROUND– add hash marks to line up with the graph above.</p> <p style="text-align: center;">←—————→</p>
C. Rotations, Rear Wheel	<p>REAR WHEEL ROTATIONS– add hash marks to line up with the graph above.</p> <p style="text-align: center;">←—————→</p>
	<p>FRONT WHEEL ROTATIONS– add hash marks to line up with the graph above.</p> <p style="text-align: center;">←—————→</p>

Georgia Department of Education
 Georgia Standards of Excellence Framework
GSE Pre-Calculus • Unit 1

10a. **SPEED** part 1 - : How fast does the center point of each tire travel across the ground in cm/s?

<i>LARGE (REAR) TIRE CENTER POINT SPEED</i>	<i>SMALL (FRONT) TIRE CENTER POINT SPEED</i>

10b. **SPEED** part 2 - : How many rotations per second does each tire make?

<i>LARGE (REAR) TIRE RPS</i>	<i>SMALL (FRONT) TIRE RPS</i>

10c. What is the relationship between rotations of the small tire vs. the large tire?

Discussion Questions:

11. What would the equations (for both the rear and the front wheel) for the height of the stickers with respect to time in seconds if the stickers both started on the GROUND?

REAR TIRE	FRONT TIRE

Georgia Department of Education
 Georgia Standards of Excellence Framework
 GSE Pre-Calculus • Unit 1

12. For the equations you found in #11, what does each of the following terms actually MEAN for the wheels on this Mouse Trap Race Car? Amplitude is done for you so that you can see how to answer each of these.

Term	Explain this relative to the equation AND the cars. Also-how would changing this number change the graph, and how would changing this number change the appearance of the car's wheels?
Amplitude	<i>EXAMPLE: You find the number that affects amplitude on the outside of the trig function. For example, in $f(\theta) = a\sin(b\theta - c) + d$, amplitude is a, because it is multiplying the trigonometric function. The multiplier multiplies the range, and stretches the graph vertically. It goes "a" many times higher and lower.</i>
Period	
Frequency	
Vertical Shift	
Horizontal Phase Shift	
Midline	

13. So what is the equation of the height of a sticker with respect to time if the sticker of a wheel with a radius of 10m on which the sticker starts at the bottom but that moves left to right (clockwise), and the center of the wheel moves forward at a rate of 30 m/s, and what is the equation of the wheel with all the same attributes, except the wheel is 5 times larger?

--	--

STEAMROLLER WITH STICKERS FOLLOW UP:

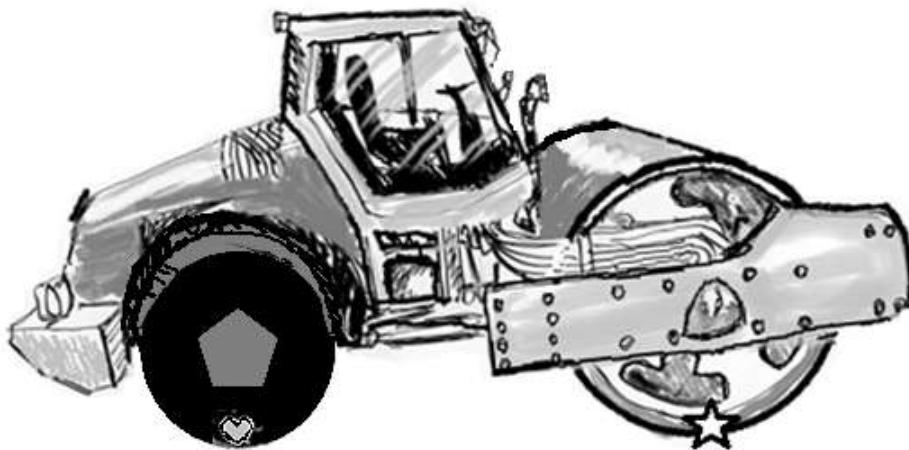

Junior has a toy steamroller and a little sister Trudy who loves stickers. She put a heart sticker on the bottom of the steamroller's rear wheel, and a star sticker on the front of the roller cylinder, which acts as a front wheel. The toy steamroller is drawn to scale above. Junior has allowed you to borrow his steamroller. You are in the hallway at school and you put the steamroller on the ground to roll to Trudy, who is exactly 10 feet away. You place the steamroller on the ground, with both of the stickers on the underside of their wheels. Suppose you push this steam roller toy down a 10-foot hallway at a steady rate of 2.4 feet per second to Trudy.

Let: R := a function which defines the height of the heart sticker on the rear wheel.

F := a function which defines the height of the star sticker on the front cylinder (wheel).

Answer the following:

1. How long will it be before the steamroller reaches the end of the hall?
2. Measure the wheels with a ruler and find the equations for

♥ $R(\theta)$ in radians, $R(d)$ in length, and $R(t)$ in seconds.

$F(\theta)$ in radians, $F(d)$ in length, and $F(t)$ in seconds.

3. Either by hand or using technology, create a graph of both equations on the same axes which show the heights of the stickers at given times for a minimum of two iterations each.
4. Highlight the graph and write the inequalities that show the times that you can see both stickers at the same time if you are standing behind the toy as you push it toward Trudy, and

Georgia Department of Education
Georgia Standards of Excellence Framework
GSE Pre-Calculus • Unit 1

you are able to see from the very bottom of the wheel, the point where the sticker started out, all the way to the top of the wheel before you lose sight of the sticker again.

Formative Assessment Lesson: Ferris Wheel

Source: Formative Assessment Lesson Materials from Mathematics Assessment Project
<http://map.mathshell.org/materials/download.php?fileid=1252>

ESSENTIAL QUESTION:

- How are triangles proven to be congruent?

TASK COMMENTS:

Tasks and lessons from the Mathematics Assessment Project are specifically designed to help teachers effectively formatively assess their students. The way the tasks and lessons are designed gives the teacher a clear understanding of what the students are able to do and not do. Within the lesson, teachers will find suggestions and question prompts that will help guide students towards understanding. For more information access the MAP website:

<http://www.map.mathshell.org/materials/background.php?subpage=formative>

The task, *Ferris Wheel*, is a Formative Assessment Lesson (FAL) that can be found at the website:
<http://map.mathshell.org/materials/lessons.php?taskid=427&subpage=concept>

The FAL document provides a clear lesson design, from the opening of the lesson to the closing of the lesson.

The PDF version of the task can be found at the link below:
<http://map.mathshell.org/materials/download.php?fileid=1252>

STANDARDS ADDRESSED IN THIS TASK:

MGSE9-12.F.TF.1 Understand radian measure of an angle as the length of the arc on the unit circle subtended by the angle.

MGSE9-12.F.TF.2 Explain how the unit circle in the coordinate plane enables the extension of trigonometric functions to all real numbers, interpreted as radian measures of angles traversed counterclockwise around the unit circle.

Model periodic phenomena with trigonometric functions

MGSE9-12.F.TF.5 Choose trigonometric functions to model periodic phenomena with specified amplitude, frequency, and midline.

Standards for Mathematical Practice

This lesson uses all of the practices with emphasis on:

4. **Model with mathematics** by expecting students to use mathematical expressions/equations to represent situations.
7. **Look for and make use of structure** by expecting students to apply rules, look for patterns and analyze structure.

As the Wheel Turns

This content is licensed under a [Creative Commons Attribution-ShareAlike 3.0 Unported License](https://creativecommons.org/licenses/by-sa/3.0/).

Mathematical Goals

- Use trigonometric functions to model the movement of cyclical phenomena.
- Interpret features of periodic graphs in terms of a real-world context.

Georgia Standards of Excellence

Interpret functions that arise in applications in terms of the context.

MGSE9-12.F.IF.4 Using tables, graphs, and verbal descriptions, interpret the key characteristics of a function which models the relationship between two quantities. Sketch a graph showing key features including: intercepts; interval where the function is increasing, decreasing, positive, or negative; relative maximums and minimums; symmetries; end behavior; and periodicity.

Standards for Mathematical Practice

1. Make sense of problems and persevere in solving them.
2. Reason abstractly and quantitatively.
3. Construct viable arguments and critique the reasoning of others.
4. Model with mathematics.
5. Use appropriate tools strategically.
6. Attend to precision.
7. Look for and make use of structure.
8. Look for and express regularity in repeated reasoning.

Introduction

In this task, students use trigonometric functions to model the movement of a point around a wheel and, in the case of part (c), through space (F-TF.5). Students also interpret features of graphs in terms of the given real-world context (F-IF.4).

In order to complete part (a), students must use the linear speed of the wheel to determine its angular speed, and use the unit circle definitions of trigonometric functions (or judicious guessing) to construct a function that gives the vertical position of the point P . In part (c), students must use similar ideas to write a function for the horizontal position of the point P with respect to the center of the wheel, and then combine this with the horizontal position of the center of the wheel to obtain the point's horizontal position with respect to the starting point. The difficulty of the task likely makes it more appropriate for collaborative work than as an individual exercise.

Materials

- Pencil
- Handout

As the Wheel Turns

A wheel of radius 0.2 meters begins to move along a flat surface so that the center of the wheel moves forward at a constant speed of 2.4 meters per second. At the moment the wheel begins to turn, a marked point P on the wheel is touching the flat surface.

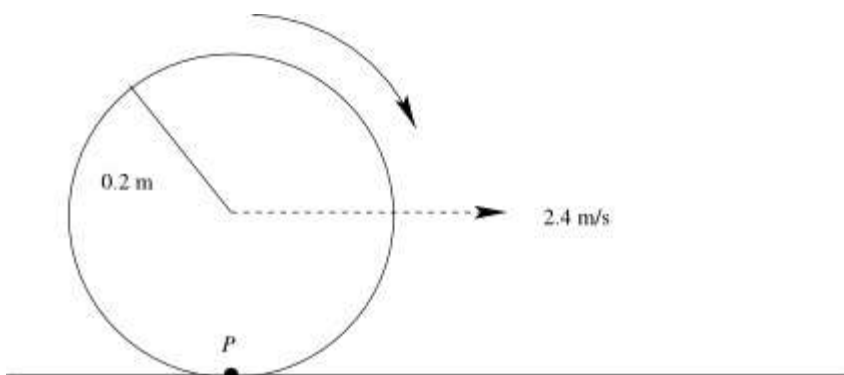

(a) Write an algebraic expression for the function y that gives the height (in meters) of the point P , measured from the flat surface, as a function of t , the number of seconds after the wheel begins moving.

Since we are currently interested only in the vertical position of the point P , we can ignore the fact that the wheel is moving horizontally and pretend that the center of the wheel is stationary. To find an expression for $y(t)$, we start by defining θ to be the angle shown below:

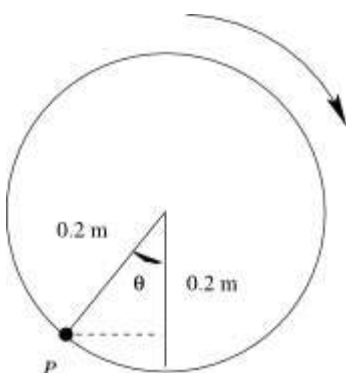

Since the wheel moves at a speed of 2.4 m/s, and the circumference of the wheel is $2\pi r = 0.4\pi$ meters, the wheel completes $\frac{2.4}{0.4\pi} = \frac{6}{\pi}$ rotations per second. This means that θ is

increasing at a rate of $\frac{6}{\pi} \cdot 2\pi = 12$ radians per second. So $\theta = 12t$, where t is the time in seconds after the wheel begins to move.

We observe that the height of the point P is equal to 0.2 meters, the height of the center of the wheel, plus or minus the vertical part of the radius from the center of the wheel to P . The vertical part of the radius is $0.2 \cos \theta = 0.2 \cos(12t)$, so the height of the point P is given by

$$y(t) = 0.2 - 0.2 \cos(12t)$$

(b) Sketch a graph of the function y for $t > 0$. What do you notice about the graph? Explain your observations in terms of the real-world context given in this problem.

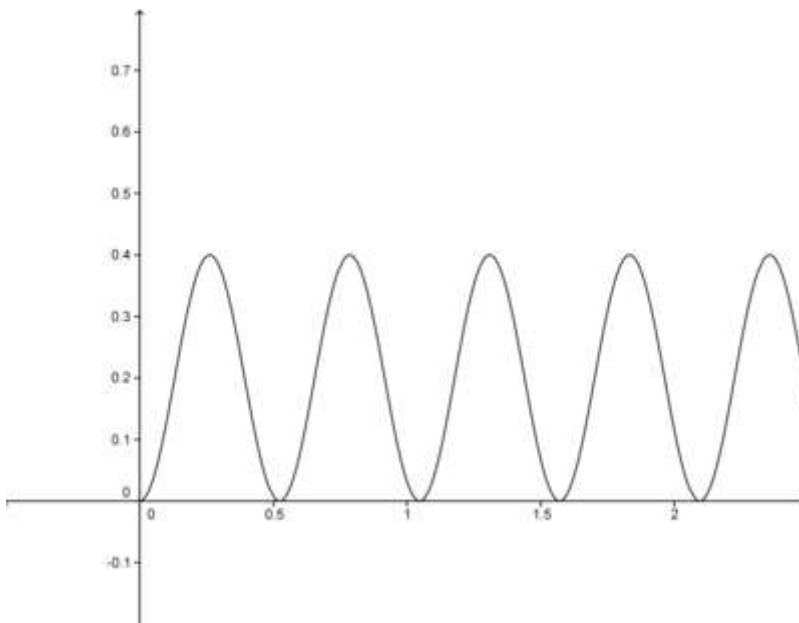

Graphing the function $y(t)$, we notice that the graph of the function touches the line $y = 0$ but does not go below this line. This makes sense in terms of the real-world context, because the height of the point P reaches zero but does not go below zero, since the point P never goes beneath the surface.

(c) We define the horizontal position of the point P to be the number of meters the point has traveled forward from its starting position, disregarding any vertical movement the point has made. Write an algebraic expression for the function x that gives the horizontal position (in meters) of the point P as a function of t , the number of seconds after the wheel begins moving.

If we pretend temporarily that the center of the wheel is stationary, we can use our finding from part (a) that $\theta = 12t$ to show that the horizontal position of the point P , with respect to the center of the circle, is $-0.2 \sin(12t)$. (This is because the length of the horizontal part of the radius from the center to point P is $0.2 \sin(12t)$, and this part

initially points to the left.)

Now we take into account the horizontal motion of the center of the wheel. Since the center is advancing at a rate of 2.4 meters per second, the horizontal position of the point P is equal to

$$x(t) = 2.4t - 0.2\sin(12t)$$

(d) Sketch a graph of the function x for $t > 0$. Is there a time when the point P is moving backwards? Use your graph to justify your answer.

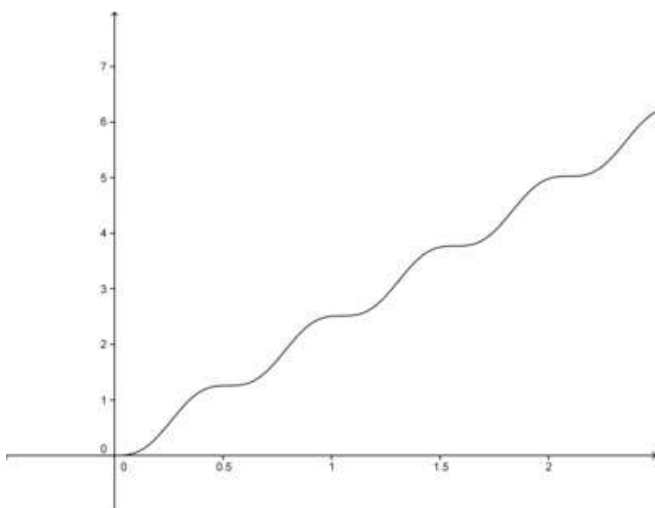

Note that the scale for this graph is not the same as the scale for the graph given in part (b).

To determine whether the point P ever moves backwards, we look at the graph of $x(t)$ to see whether x ever decreases. The graph suggests that x does not decrease, though there are points at which the graph is momentarily horizontal. At the times corresponding to these points, the horizontal movement of P has momentarily slowed to a halt. If we put the graphs of $x(t)$ and $y(t)$ on the same set of axes, we can also observe that the times when P stops advancing horizontally are the same times when P touches the surface.

As the Wheel Turns

A wheel of radius 0.2 meters begins to move along a flat surface so that the center of the wheel moves forward at a constant speed of 2.4 meters per second. At the moment the wheel begins to turn, a marked point P on the wheel is touching the flat surface.

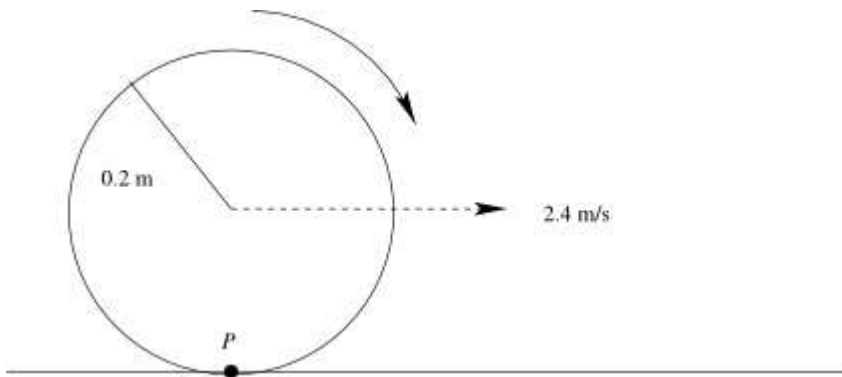

(a) Write an algebraic expression for the function y that gives the height (in meters) of the point P , measured from the flat surface, as a function of t , the number of seconds after the wheel begins moving.

(b) Sketch a graph of the function y for $t > 0$. What do you notice about the graph? Explain your observations in terms of the real-world context given in this problem.

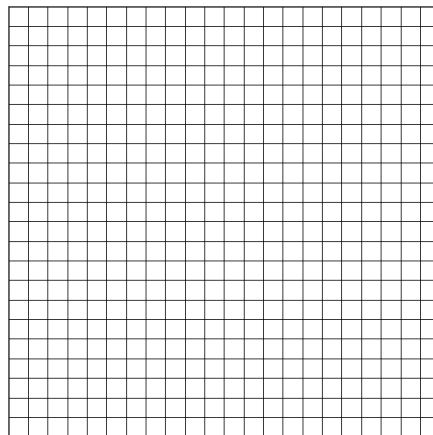

Georgia Department of Education
Georgia Standards of Excellence Framework
GSE Pre-Calculus • Unit 1

(c) We define the horizontal position of the point P to be the number of meters the point has traveled forward from its starting position, disregarding any vertical movement the point has made. Write an algebraic expression for the function x that gives the horizontal position (in meters) of the point P as a function of t , the number of seconds after the wheel begins moving.

(d) Sketch a graph of the function x for $t > 0$. Is there a time when the point P is moving backwards? Use your graph to justify your answer.

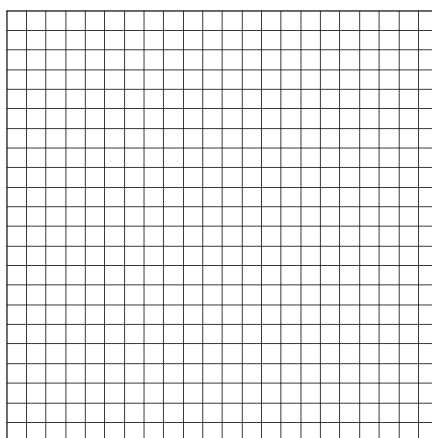

Transforming Sinusoidal Graphs

Mathematical Goals

- Graph transformations of $y = \sin(x)$ and $y = \cos(x)$
- Determine the effects of a , b , c , and d on the graphs of $y = a \sin[b(x - c)] + d$ and $y = a \cos[b(x - c)] + d$

Georgia Standards of Excellence

MGSE9-12.F.IF.7 Graph functions expressed algebraically and show key features of the graph both by hand and by using technology.

MGSE9-12.F.IF.7e Graph ~~exponential and logarithmic functions, showing intercepts and end behavior, and~~ trigonometric functions, showing period, midline, and amplitude.

Standards for Mathematical Practice

- Make sense of problems and persevere in solving them.
- Reason abstractly and quantitatively.
- Construct viable arguments and critique the reasoning of others.
- Model with mathematics.
- Use appropriate tools strategically.
- Attend to precision.
- Look for and make use of structure.
- Look for and express regularity in repeated reasoning.

Introduction

In this task students will explore the transformations of $y = \sin(x)$ and $y = \cos(x)$. They will explore and make conjectures about the effects a , b , c , and d upon graphs of $y = a \sin[b(x - c)] + d$ and $y = a \cos[b(x - c)] + d$. The concepts of amplitude, period, equation of the midline, and phase shift are connected to the effects of a , b , c , and d on the graph.

Materials

- Graphing calculators or a graphing utility on a computer

The standard forms of the sine and cosine functions are

$$y = a \sin[b(x - c)] + d \quad \text{and} \quad y = a \cos[b(x - c)] + d.$$

In this task you will determine how a , b , c , and d transform the graphs of the parent functions $y = \sin(x)$ and $y = \cos(x)$.

Georgia Department of Education
Georgia Standards of Excellence Framework
GSE Pre-Calculus • Unit 1

1. Graph $y = \sin(x)$ over the interval $[-2\pi, 2\pi]$.
- a. Graph $y = \sin(x) + 2$. How does this graph compare to the graph of $y = \sin(x)$?
What is the equation of the midline of $y = \sin(x) + 2$?

The graph of $y = \sin(x)$ is shifted 2 units up. Equation is $y = 2$. The midline is located halfway between the maximum and minimum values.

- b. Graph $y = \sin(x) - 3$. How does this graph compare to the graph of $y = \sin(x)$?
What is the equation of the midline of $y = \sin(x) - 3$?

Equation of midline is $y = -3$

- c. Explain what happens to the graph of $y = \sin(x)$ when a constant is added to $\sin(x)$. What do you notice about the midline?

The graph of $y = \sin(x)$ is shifted vertically if a constant is added to $\sin(x)$. If the constant is positive, the graph is shifted up; if the constant is negative, the graph is shifted down. The midline of $y = \sin(x)$ is shifted the same number of units as the graph---the equation of the midline is $y =$ "the constant that is added to $\sin(x)$."

- d. The standard form of the sine function is $y = a \sin[b(x - c)] + d$. Which value (a , b , c , or d) is related to the equation of the midline? What is the equation of the midline?

d is related to the equation of the midline; the equation is $y = d$

2. Graph $y = \sin(x)$ over the interval $[-2\pi, 2\pi]$.

- a. Graph $y = \sin\left(x - \frac{\pi}{2}\right)$ and $y = \sin\left(x + \frac{\pi}{2}\right)$ and compare their graphs to that of $y = \sin(x)$. What do you observe?

$y = \sin\left(x - \frac{\pi}{2}\right)$ shifts the graph of $y = \sin(x)$ to the right $\pi/2$ units. $y = \sin\left(x + \frac{\pi}{2}\right)$ shifts the graph of $y = \sin(x)$ to the left $\pi/2$ units. This may be hard for students to see. Remind them of how the graph of $y = (x - 2)^2$ compares to the graph of $y = x^2$; this may help them see there is a horizontal translation.

- b. Explain what happens when a constant is subtracted from the variable x in $y = \sin(x)$.

Georgia Department of Education
Georgia Standards of Excellence Framework
GSE Pre-Calculus • Unit 1

- What is the amplitude of $y = \frac{1}{2} \sin(x)$? *1/2*
 - The transformation that affects the amplitude is comparable to which of the transformations you studied earlier? *Vertical stretch or shrink*
- e. In the standard form of the sine function $y = a \sin[b(x - c)] + d$, which value (a , b , c , or d) affects the amplitude? *the value a*
6. How do you think the graph of $y = -3 \sin(x)$ compares to the graph of $y = \sin(x)$? Make your prediction and then check by graphing the functions on the calculator. Were you correct? Why do you think this happened?

Encourage students to see this is really two transformations. First $y = \sin(x)$ is transformed by

$y = 3\sin(x)$. This stretches the maximum and minimum values to 3 and -3, respectively. Then $y = -3\sin(x)$ is just the vertical reflection of $y = 3\sin(x)$. (They could also first consider $y = -\sin(x)$ to transform $y = \sin(x)$ with a vertical reflection; then $y = 3(-\sin(x))$ “stretches” $y = -\sin(x)$. This is because $-3\sin(x) = -[3\sin(x)] = 3[-\sin(x)]$.)

Because the amplitude is the distance between the midline and the maximum (or minimum) value, the amplitude is always positive. Therefore, the amplitude of $y = -3 \sin(x)$ is $|-3| = 3$.

7. Graph $y = \sin(x)$ over the interval $[-2\pi, 2\pi]$.
- a. How does the graph of $y = \sin(2x)$ compare to the graph of $y = \sin(x)$?

Some may say the graph of $y = \sin(2x)$ is moving faster. More cycles are created.

- b. Compare the graphs of $y = \sin(3x)$ and $y = \sin(4x)$ to the graph of $y = \sin(x)$. What do you observe?

You get many more cycles with these functions.

- c. Repeat parts (a) and (b) by graphing the functions over the interval $[0, 2\pi]$. What do you observe?

Over $[0, 2\pi]$ one cycle of $y = \sin(x)$ occurs. Over $[0, 2\pi]$ $y = \sin(2x)$ has 2 cycles, $y = \sin(3x)$ has 3 cycles, and $y = \sin(4x)$ has 4 cycles. In other words, in the distance it takes $y = \sin(x)$ to complete one cycle, $y = \sin(2x)$ completes 2 cycles, for example.

Georgia Department of Education
Georgia Standards of Excellence Framework
GSE Pre-Calculus • Unit 1

- d. Now graph $y = \sin(\frac{1}{2}x)$ over the interval $[0, 2\pi]$ and compare its graph to $y = \sin(x)$ graphed over the same interval. Observations?

Only $\frac{1}{2}$ cycle is graphed over the interval $[0, 2\pi]$. In the distance it takes $y = \sin(x)$ to complete one cycle, $y = \sin(\frac{1}{2}x)$ completes only $\frac{1}{2}$ cycle.

- e. What characteristic of sinusoidal functions appears to be affected when the variable x is multiplied by a constant in $y = \sin(x)$?

The period is affected. Since only $\frac{1}{2}$ cycle is graphed over a distance of 2π , then one complete cycle will be graphed over a distance of 4π . Thus, the period of $y = \sin(\frac{1}{2}x)$ is 4π .

- f. In trigonometry, we say this transformation has affected the **period** of $y = \sin(x)$.

- What is the period of $y = \sin(x)$? 2π
- What is the period of $y = \sin(2x)$? π
- What is the period of $y = \sin(3x)$? $\frac{2\pi}{3}$
- What is the period of $y = \sin(4x)$? $\frac{\pi}{2}$
- What is the period of $y = \sin(\frac{1}{2}x)$? 4π

Encourage students to look for patterns.

The transformation that affects the period is comparable to a horizontal stretch (or shrink).

- g. Based on your observations, if $y = \sin(5x)$ is graphed over $[0, 2\pi]$, how many cycles will occur. What is the period of $y = \sin(5x)$?

5 cycles will occur; the period is $\frac{2\pi}{5}$.

- h. In the standard form of the sine function $y = a \sin[b(x - c)] + d$, it is the value b that affects the period. If you graphed $y = \sin(bx)$ where $b > 0$, how many cycles do you predict will occur over $[0, 2\pi]$? What is the period of $y = \sin(bx)$ where $b > 0$?

b cycles will occur over $[0, 2\pi]$ and the period is $\frac{2\pi}{b}$. In general, if $y = \sin(bx)$, the number of cycles in $[0, 2\pi]$ is $|b|$, and the period is $\frac{2\pi}{|b|}$.

Georgia Department of Education
 Georgia Standards of Excellence Framework
 GSE Pre-Calculus • Unit 1

8. Using your conjectures from above, **sketch** by hand the graph of these functions. Use your calculator to check your graphs.

a. $y = 2 \sin(x) + 2$

b. $y = 2 \sin(2x)$

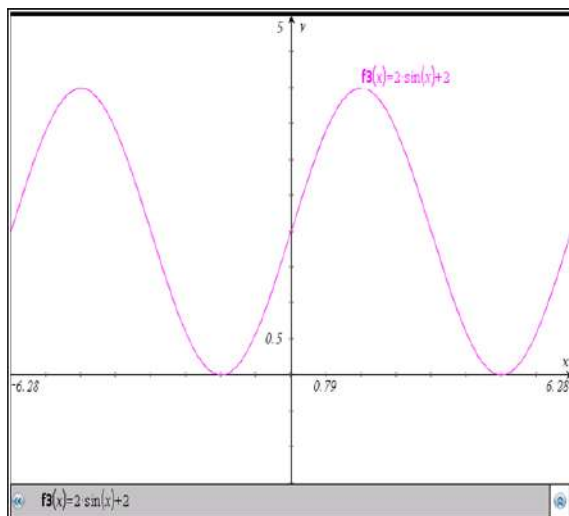

9. The general form of the cosine function is $y = a \cos[b(x - c)] + d$. The graph of the parent function $y = \cos(x)$ is affected in a similar way by a , b , c , and d . Make a prediction about the graphs of the following functions and then check by graphing the function on the calculator. For each function give the equation of the midline, the amplitude, the period, and the phase shift.

a. $y = \cos(x) + 3$

b. $y = \cos\left(x - \frac{\pi}{4}\right)$

c. $y = 2 \cos(x)$

d. $y = \cos(2x)$

e. $y = -3\cos(4x)$

	<i>Midline</i>	<i>Amplitude</i>	<i>Period</i>	<i>Phase shift</i>
$y = \cos(x) + 3$	$y = 3$	1	2π	0
$y = \cos\left(x - \frac{\pi}{4}\right)$	$y = 0$	1	2π	$\pi/4$ so the shift is $\pi/4$ to the right
$y = 2 \cos(x)$	$y = 0$	2	2π	0
$y = \cos(2x)$	$y = 0$	1	π	0
$y = 2 \cos(x)$	$y = 0$	2	2π	0

Georgia Department of Education
Georgia Standards of Excellence Framework
GSE Pre-Calculus • Unit 1

--	--	--	--

From the work in this task, students should be able to make the following generalizations for the functions $y = a \sin[b(x - c)] + d$ and $y = a \cos[b(x - c)] + d$:

- *The equation of the midline is $y = d$.*
- *The amplitude is $|a|$. The amplitude is the distance between the midline and the maximum (or minimum) value. If a is negative, there is also a vertical reflection. (The amplitude is always positive.)*
- *The period is $\frac{2\pi}{b}$ for positive values of b . (The period is always positive.)*
- *The phase shift is c . If c is positive, the shift is to the right. If c is negative, the shift is to the left.*

If the equation of the function is not in standard form, you must rewrite the function in standard form in order to determine the amplitude, equation of midline, period, and phase shift. For

example, the function $y = \sin(2x - \pi)$ is equivalent to $y = \sin\left[2\left(x - \frac{\pi}{2}\right)\right]$.

Transforming Sinusoidal Graphs

The standard forms of the sine and cosine functions are

$$y = a \sin[b(x - c)] + d \quad \text{and} \quad y = a \cos[b(x - c)] + d.$$

In this task you will determine how a , b , c , and d transform the graphs of the parent functions $y = \sin(x)$ and $y = \cos(x)$.

1. Graph $y = \sin(x)$ over the interval $[-2\pi, 2\pi]$.
 - a. Graph $y = \sin(x) + 2$. How does this graph compare to the graph of $y = \sin(x)$?
What is the equation of the midline of $y = \sin(x) + 2$?
 - b. Graph $y = \sin(x) - 3$. How does this graph compare to the graph of $y = \sin(x)$?
What is the equation of the midline of $y = \sin(x) - 3$?
 - c. Explain what happens to the graph of $y = \sin(x)$ when a constant is added to $\sin(x)$. What do you notice about the midline?
 - d. The standard form of the sine function is $y = a \sin[b(x - c)] + d$. Which value (a , b , c , or d) is related to the equation of the midline? What is the equation of the midline?
2. Graph $y = \sin(x)$ over the interval $[-2\pi, 2\pi]$.
 - a. Graph $y = \sin\left(x - \frac{\pi}{2}\right)$ and $y = \sin\left(x + \frac{\pi}{2}\right)$ and compare their graphs to that of $y = \sin(x)$. What do you observe?
 - b. Explain what happens when a constant is subtracted from the variable x in $y = \sin(x)$.
 - c. In trigonometry, this kind of transformation is called a **phase shift**. A phase shift is comparable to which of the transformations you studied earlier?
 - d. Which value (a , b , c , or d) in the equation $y = a \sin[b(x - c)] + d$ creates a phase shift?
3. Based on your observations so far, sketch the graph of $y = \sin\left(x + \frac{\pi}{4}\right) - 2$ and then check with your calculator.

Georgia Department of Education
Georgia Standards of Excellence Framework
GSE Pre-Calculus • Unit 1

4. Based on what you know about transformations of graphs, predict how you think the graph of $y = -\sin(x)$ will compare to the graph of $y = \sin(x)$.

Check your prediction by graphing both functions on the calculator. Were you correct? Explain what happens to the graph of $y = \sin(x)$ when $\sin(x)$ is multiplied by -1 .

From your earlier work on transformations, what do we call this kind of transformation?

5. Graph the parent function $y = \sin(x)$ over the interval $[-2\pi, 2\pi]$ and compare the graphs of the following functions to its graph.
- $y = 2 \sin(x)$
 - $y = \frac{1}{2} \sin(x)$
 - Explain what happens to the graph of $y = \sin(x)$ when $\sin(x)$ is multiplied by a constant.
 - In trigonometry, we say this transformation has affected the **amplitude** of $y = \sin(x)$.
 - What is the amplitude of $y = 2 \sin(x)$?
 - What is the amplitude of $y = \frac{1}{2} \sin(x)$?
 - The transformation that affects the amplitude is comparable to which of the transformations you studied earlier?
 - In the standard form of the sine function $y = a \sin[b(x - c)] + d$, which value (a , b , c , or d) affects the amplitude?
6. How do you think the graph of $y = -3 \sin(x)$ compares to the graph of $y = \sin(x)$? Make your prediction and then check by graphing the functions on the calculator. Were you correct? Why do you think this happened?

Because the amplitude is the distance between the midline and the maximum (or minimum) value, the amplitude is always positive. Therefore, the amplitude of $y = -3 \sin(x)$ is $|-3| = 3$.

7. Graph $y = \sin(x)$ over the interval $[-2\pi, 2\pi]$.
- How does the graph of $y = \sin(2x)$ compare to the graph of $y = \sin(x)$?

Georgia Department of Education
Georgia Standards of Excellence Framework
GSE Pre-Calculus • Unit 1

- b. Compare the graphs of $y = \sin(3x)$ and $y = \sin(4x)$ to the graph of $y = \sin(x)$? What do you observe?
- c. Repeat parts (a) and (b) by graphing the functions over the interval $[0, 2\pi]$. What do you observe?
- d. Now graph $y = \sin(\frac{1}{2}x)$ over the interval $[0, 2\pi]$ and compare its graph to $y = \sin(x)$ graphed over the same interval. Observations?
- e. What characteristic of sinusoidal functions appears to be affected when the variable x is multiplied by a constant in $y = \sin(x)$?
- f. In trigonometry, we say this transformation has affected the **period** of $y = \sin(x)$.
- What is the period of $y = \sin(x)$?
 - What is the period of $y = \sin(2x)$?
 - What is the period of $y = \sin(3x)$?
 - What is the period of $y = \sin(4x)$?
 - What is the period of $y = \sin(\frac{1}{2}x)$?

The transformation that affects the period is comparable to a horizontal stretch (or shrink).

- g. Based on your observations, if $y = \sin(5x)$ is graphed over $[0, 2\pi]$, how many cycles will occur. What is the period of $y = \sin(5x)$?
- h. In the standard form of the sine function $y = a \sin[b(x - c)] + d$, it is the value b that affects the period. If you graphed $y = \sin(bx)$ where $b > 0$, how many cycles do you predict will occur over $[0, 2\pi]$? What is the period of $y = \sin(bx)$ where $b > 0$?

Georgia Department of Education
Georgia Standards of Excellence Framework
GSE Pre-Calculus • Unit 1

8. Using your conjectures from above, **sketch** by hand the graph of these functions. Use your calculator to check your graphs.

a. $y = 2 \sin(x) + 2$

b. $y = 2 \sin(2x)$

9. The general form of the cosine function is $y = a \cos[b(x - c)] + d$. The graph of the parent function $y = \cos(x)$ is affected in a similar way by a , b , c , and d . Make a prediction about the graphs of the following functions and then check by graphing the function on the calculator. For each function give the equation of the midline, the amplitude, the period, and the phase shift.

a. $y = \cos(x) + 3$

b. $y = \cos\left(x - \frac{\pi}{4}\right)$

c. $y = 2 \cos(x)$

d. $y = \cos(2x)$

e. $y = -3\cos(4x)$

Modeling with Sinusoidal Functions

Mathematical Goals

- Given the characteristics of a graph, determine its equation
- Model periodic phenomena with a trigonometric function

Georgia Standards of Excellence

MGSE9-12.F.TF.5 Choose trigonometric functions to model periodic phenomena with specified amplitude, frequency, and midline.

Standards for Mathematical Practice

- Make sense of problems and persevere in solving them.
- Reason abstractly and quantitatively.
- Construct viable arguments and critique the reasoning of others.
- Model with mathematics.
- Use appropriate tools strategically.
- Attend to precision.
- Look for and make use of structure.
- Look for and express regularity in repeated reasoning.

Introduction

Many real life applications generate sinusoidal curves. This occurs when data are periodic. Some examples involve electric currents, musical tones, radio waves, sunrises, and weather patterns. This task includes several problems that can be modeled with a sinusoidal function.

Materials

Graphing calculator or some other graphing utility

Problem 1: The Clock Problem Revisited

Find the equation that models the data collected in the Clock Problem.

One of the tasks in this unit was the Clock Problem. If the data students collected was saved, they can use their data to write the equation of their graph. Below is the data that was given as sample data in the teacher's edition for the Clock Problem.

Given is a set of data for a toothpick of length 5.6 cm.

<i>Hrs since 6:00</i>	<i>0</i>	<i>1</i>	<i>2</i>	<i>3</i>	<i>4</i>	<i>5</i>	<i>6</i>	<i>7</i>	<i>8</i>	<i>9</i>	<i>10</i>	<i>11</i>	<i>12</i>	<i>13</i>
-----------------------	----------	----------	----------	----------	----------	----------	----------	----------	----------	----------	-----------	-----------	-----------	-----------

Georgia Department of Education
 Georgia Standards of Excellence Framework
 GSE Pre-Calculus • Unit 1

<i>Dist to the ceiling (cm)</i>	<i>17.1</i>	<i>16.2</i>	<i>14.3</i>	<i>11.1</i>	<i>8.4</i>	<i>6.3</i>	<i>5.5</i>	<i>6.3</i>	<i>8.4</i>	<i>11.1</i>	<i>14.3</i>	<i>16.2</i>	<i>17.1</i>	<i>16.2</i>
---------------------------------	-------------	-------------	-------------	-------------	------------	------------	------------	------------	------------	-------------	-------------	-------------	-------------	-------------

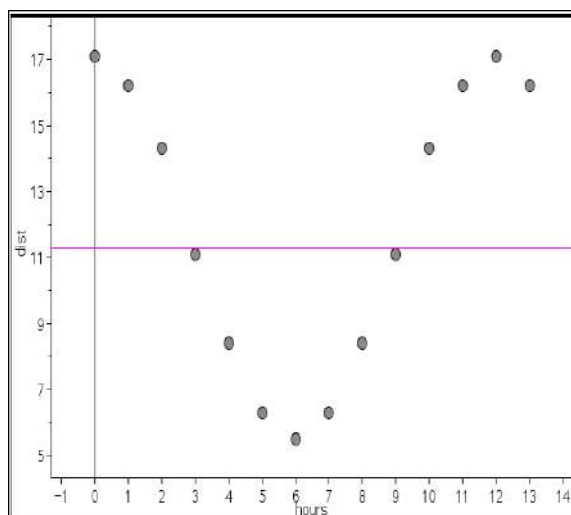

The equation can be written as a transformation of $y = \sin(x)$ or $y = \cos(x)$. Because of the shape of the scatter plot, the choice of a transformation of $y = \cos(x)$ is preferable (we can avoid a phase shift). So...our job is to write the equation in the form $y = a \cos[b(x - c)] + d$. To do so, the values of a , b , c , and d must be determined.

- The midline is $y = 11.3$ so $d = 11.3$.*
- The minimum value is 5.5, and the maximum value is 17.1. Since $17.1 - 11.3 = 5.8$, then the amplitude is 5.8 (or you could do $11.3 - 5.5 = 5.8$). Now this means $|a| = 5.8$ so we must decide whether the value of a is positive or negative. The cycle we are using to determine our equation begins at the maximum value so it has not been reflected. Thus, $a = 5.8$.*
- The period of the function is 12 since the cycle repeats every 12 hours. So $\frac{2\pi}{b} = 12$. Thus, $b = \frac{2\pi}{12} = \frac{\pi}{6}$.*
- The basic cosine function has a maximum value on the y-axis—just as this scatter plot has. Thus, there is no phase shift so $c = 0$.*

We have all the pieces so the equation is: $y = 5.8 \cos\left[\frac{\pi}{6}(x - 0)\right] + 11.3$ which is equivalent to

$$y = 5.8 \cos\left(\frac{\pi}{6}x\right) + 11.3$$

Problem 2: What's Your Temperature?

This task provides a real-life context to experience the graphs of sinusoidal functions using average daily highs and lows as a point of reference for the students. If you would prefer to replace the Atlanta data used in the task, you can access your city's average highs and lows on the internet. There are multiple resources where this information can be found. Here is one possible site for average monthly temperatures: <http://countrystudies.us/united-states/weather/> (then select the state and then the city).

Scientists are continually monitoring the average temperatures across the globe to determine if Earth is experiencing Climate Change. One statistic scientists use to describe the climate of an area is average temperature. The average temperature of a region is the mean of its average high and low temperatures.

1. The graph to the right shows the average high and low temperature in Atlanta from January to December. The average high temperatures are in red and the average low temperatures are in blue.

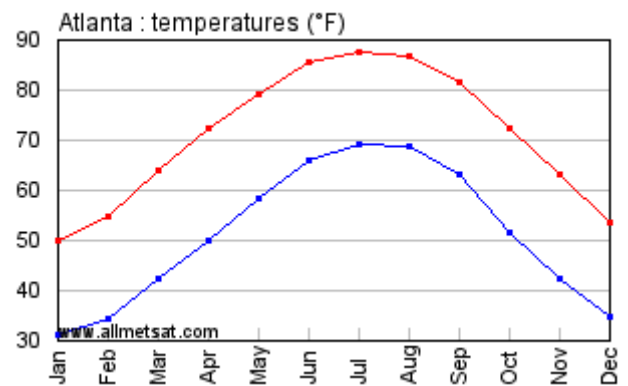

- a. How would you describe the climate of Atlanta, Georgia?

Answers will vary. Students might note the months in which the highest and lowest temperatures occur. They might compare the difference between the highs and lows to see how much the temperature tends to rise during the day. They might be surprised to see that January tends to be colder than December and July tends to be hotter than August.

- b. If you wanted to visit Atlanta, and prefer average highs in the 70's, when would you go?

April, May and October seem to have highs in the 70's.

- c. Estimate the lowest and highest **average high temperature**. When did these values occur?

*The highest average high temp seems to be around 88 °; occurred in July.
The lowest average high temp seems to be around 50 °; occurred in January*

- d. What is the range of these temperatures?

*Answers may vary depending on estimates from part c.
The range appears to be around 38 °.*

- e. Estimate the lowest and highest **average low temperature**. When did these values occur?

*The highest average low temp seems to be around 69°.
 The lowest average low temp seems to be around 31°.*

- f. What is the range of these temperatures?

*Answers may vary depending on estimates from part c.
 The range appears to be around 38°.*

2. In mathematics, a function that repeats itself in regular intervals, or **periods**, is called **periodic**.
 a. If you were to continue the temperature graphs above, what would you consider its interval, or period, to be?

The temperatures repeat themselves yearly; period is 12 months.

- b. Choose either the high or low average temperatures and sketch the graph for three intervals, or periods.

The graphs should be similar to one of the graphs below.

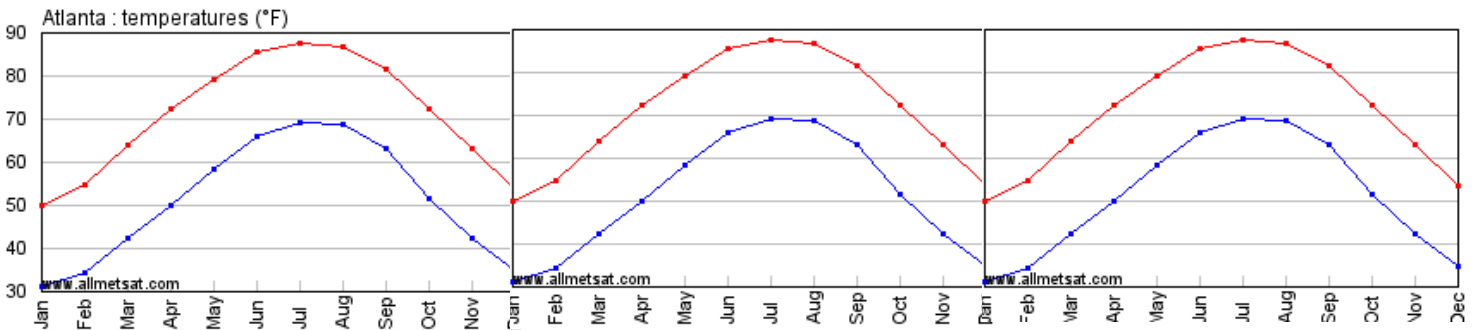

- c. What function have you graphed that looks similar to this graph?

Students should recognize the basic shape of the sine and/or cosine graph in this.

3. How do you think New York City's averages would compare to Atlanta's?

Answers may vary depending on how much students know about New York City. They may decide the entire graph would be lower since the temperatures in NYC tend to be colder than in Atlanta.

Comments: If students are very interested in comparing the two cities, have them pull up the data on the average temps and create a graph for New York.

Georgia Department of Education
Georgia Standards of Excellence Framework
GSE Pre-Calculus • Unit 1

4. Sine and cosine functions can be used to model average temperatures for cities. Based on what you know about these graphs from earlier units, why do you think these functions are more appropriate than a cubic function? Or an exponential function?

Answers may vary. Main idea is the sine and cosine continue to repeat themselves whereas the other graphs have end behaviors that would not match data that repeats.

5. Use the graph at the beginning of this problem to write the equation that models the average high temperatures in Atlanta from January to December. You can let the independent variable be the number of months since January 1; this means January corresponds to 0, February to 1, etc.

A possible equation for the average high temperatures is $y = -19 \cos\left(\frac{\pi}{6}x\right) + 69$.

Problem 3: The Ferris Wheel

There are many rides at the amusement park whose movement can be described using trigonometric functions. The Ferris Wheel is a good example of periodic movement.

Sydney wants to ride a Ferris wheel that has a radius of 60 feet and is suspended 10 feet above the ground. The wheel rotates at a rate of 2 revolutions every 6 minutes. (Don't worry about the distance the seat is hanging from the bar.) Let the center of the wheel represent the origin of the axes.

1. Write a function that describes Sydney's height above the ground as a function of the number of seconds since she was $\frac{1}{4}$ of the way around the circle (at the 3 o'clock position).

Comment:

If you want to scaffold your students through this process you can give them this series of questions to guide their thinking.

Encourage students to make a T-table of the data and a sketch of the graph based on the movement of the Ferris wheel before they start trying to create an equation.

What is the period of the function?

2 revolutions every 6 minutes means one complete revolution every 3 minutes, so the period is 3 minutes.

Since the period is $\frac{2\pi}{b}$, we have $\frac{2\pi}{b} = 3$.

If $\frac{2\pi}{b} = 3$, then $b = \frac{2\pi}{3}$.

What is the maximum height?

The maximum height is $10 + 60 + 60 = 130$ feet

What is the minimum height?

The minimum height is 10 feet

What is the midline of the function?

The midline is the average of the max and min height. The midline is at $y = 70$ feet so $d = 70$.

What is the amplitude of the function?

The amplitude is $\frac{1}{2}$ the distance between the max and min.

The amplitude is $(130-10)/2=60$. Because the cycle we are looking begins on the y-axis and then increases, a is positive (the cycle is not inverted). Thus, $a = 60$.



A possible equation is $f(t) = 60 \sin\left(\frac{2\pi}{3}t\right) + 70$ where $t =$ time since Sydney was at 3 o'clock position the first time. $f(t)$ represents her distance from the ground.

2. How high is Sydney after 1.25 minutes?

$$f(t) = 60 \sin\left(\frac{2\pi}{3}(1.25)\right) + 70$$

Sydney is 100 feet above the ground.

3. Sydney's friend got on after Sydney had been on the Ferris wheel long enough to move a quarter of the way around the circle. How would a graph of her friend's ride compare to the graph of Sydney's ride? What would the equation for Sydney's friend be?

The graph would be shifted to the right by a quarter of the period.

$$f(t) = 60 \sin\left[\frac{2\pi}{3}(t - 0.75)\right] + 70$$

Problem 4: Just Swingin’ Around

Suppose Tarzan is swinging back and forth on his grapevine. As he swings, he goes back and forth over the river bank, hovering alternately over land and water. Jane decides to model his motion mathematically and starts her stopwatch.

Let t be the number of seconds the stopwatch reads and let y be the number of meters Tarzan is from the riverbank (not his height). Assume y varies sinusoidally with t and that y is positive when Tarzan is over water and negative when Tarzan is over land.



Jane finds that at 2 seconds, Tarzan is at one end of his swing 23 feet from the riverbank over land. At 5 seconds, Tarzan is at the other end of his swing 17 feet from the riverbank over water.

1. Represent the function with a table. The independent variable is time t (in seconds) and the dependent variable is Tarzan’s distance (in meters) from the riverbank. Determine at least 4 values for the table.

<i>Time (sec)</i>	<i>2</i>	<i>5</i>	<i>8</i>	<i>11</i>	<i>14</i>
<i>Dist (meters)</i>	<i>23</i>	<i>-17</i>	<i>23</i>	<i>-17</i>	<i>23</i>

2. Sketch a graph of the function. Label the axes and indicate the scale used.
3. Determine the equation to represent Tarzan’s distance, y , from the riverbank as a function of time, t .

A possible equation is: $y = 20 \cos\left[\frac{\pi}{3}(t-2)\right] + 3$ There are other equations that are equivalent to this one. The one you write depends upon the cycle you focus upon. For the equation written, the cycle from 2 seconds to 8 seconds was used.

4. Once you have the equation of the function, answer the questions:
 - a. Where was Tarzan when Jane started her stopwatch?

This happens at $t = 0$. The value of the function at $t = 0$ is -7 so Tarzan was 7 meters from the riverbank and was over water since the value is negative.

- b. How long after Jane started the stopwatch was Tarzan directly over the riverbank?
This occurs when $y = 0$ so you need to look for the smallest x -intercept and this is approx $x = .36$. So the first time Tarzan was directly over the riverbank was about .36 seconds after Jane started the stopwatch.

Georgia Department of Education
Georgia Standards of Excellence Framework
GSE Pre-Calculus • Unit 1

- c. How long is Tarzan over water?

Use the graph to see that at 3.64 sec he crossed the riverbank to begin his swing over water (this is the second x -intercept on the graph). The next x -intercept is 6.36 so this is when he crosses the riverbank to go from over water to over land. Therefore, he was over water $6.36 - 3.64 = 2.72$ sec.

- d. Where will Tarzan be one minute from the time Jane started the stopwatch?

This will be when $t = 1$. The value of y at $t = 1$ is 13. This means Tarzan is 13 meters from the riverbank over land when Jane started the stopwatch.

Problem 5: A Steamboat Ride

Mark Twain sat on the deck of a river steamboat. As the paddlewheel turned, a brightly painted yellow dot on the paddle blade moved in such a way that its distance from the water's surface was a sinusoidal function of time.

When the watch read 4 seconds, the dot was at its highest point, 16 feet above the water's surface. The wheel's diameter was 18 feet and it completed a revolution every 10 seconds.



Encourage students to use an object such as a circular lid to model the situation.

1. Represent the function with a table. The independent variable is time t (in seconds) and the dependent variable is the distance of the dot (in feet) from the water's surface (a negative value for the dependent variable implies the notch is underwater). Determine at least 4 values for the table .

<i>Time (sec)</i>	<i>4</i>	<i>9</i>	<i>14</i>	<i>19</i>	<i>24</i>
<i>Distance (ft)</i>	<i>16</i>	<i>-2</i>	<i>16</i>	<i>-2</i>	<i>16</i>

2. Sketch a graph of the function. Label the axes and indicate the scale used.
3. Determine an equation that models the distance, d , of the dot from the water's surface as a function of time, t .

To find the equation, determine the midline, the amplitude, the period, and the phase shift. These are needed to determine the values of a , b , c , and d . You'll need to focus on one cycle to determine whether you'll write in terms of the sine or cosine. This cycle also determines whether the value of a used is positive or negative and what value of c you will use. Using the cycle from 4 sec to 16 sec, the graph is a transformed cosine function with a phase shift of 2 sec and a positive value for a . The midline is at $y = 7$ so $d = 7$. The maximum value is 16 so the amplitude is 9 and $a = 9$. The period is 10 sec so solving $\frac{2\pi}{b} = 10$ we get $b = \frac{\pi}{5}$. Also $c =$

4. Therefore, the equation is $y = 9 \cos \left[\frac{\pi}{5} (t - 4) \right] + 7$

Georgia Department of Education
Georgia Standards of Excellence Framework
GSE Pre-Calculus • Unit 1

4. After you have the equation of the function, answer these questions:

- a. How far above the surface was the dot when Mark's stopwatch read 5 seconds?

Find y when $d = 5$. The dot was about 14.3 feet above the surface of the water.

- b. How long was the dot below the water's surface?

The first positive x -intercept at $x \cong 7.92$ indicates when the dot was directly at the surface and about to go under. At $x \cong 10.08$, the second positive x -intercept, the dot was again at the surface and emerging from the water. Therefore, it was under the water for about $10.08 - 7.92 = 2.16$ sec

- c. From the time the stopwatch was started, when was the first time the dot was at the surface of the water?

The first time it was at the surface of the water is represented by the first positive x -intercept—at time 7.92 seconds.

- d. At the time found in part c, was it emerging from or entering the water? How do you know?

It was entering the water because the y values for x just to the left of $x = 7.92$ are positive while the y values for x just to the right of 7.92 are negative.

Modeling with Sinusoidal Functions

Problem 1: The Clock Problem Revisited

Find the equation that models the data collected in the Clock Problem.

Problem 2: What's Your Temperature?

Scientists are continually monitoring the average temperatures across the globe to determine if Earth is experiencing Climate Change. One statistic scientists use to describe the climate of an area is average temperature. The average temperature of a region is the mean of its average high and low temperatures.

1. The graph to the right shows the average high and low temperature in Atlanta from January to December. The average high temperatures are in red and the average low temperatures are in blue.

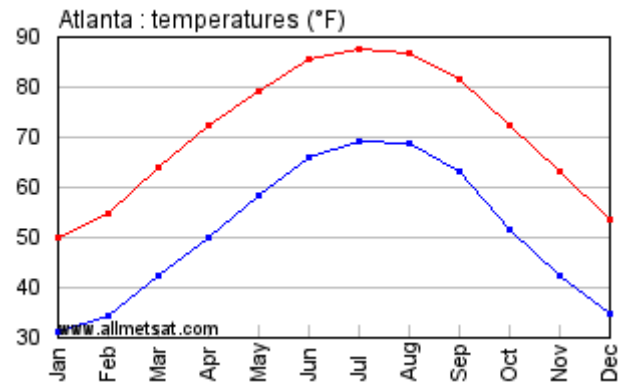

- a. How would you describe the climate of Atlanta, Georgia?
 - b. If you wanted to visit Atlanta, and prefer average highs in the 70's, when would you go?
 - c. Estimate the lowest and highest **average high temperature**. When did these values occur?
 - d. What is the range of these temperatures?
 - e. Estimate the lowest and highest **average low temperature**. When did these values occur?
 - f. What is the range of these temperatures?
2. In mathematics, a function that repeats itself in regular intervals, or **periods**, is called **periodic**.
 - a. If you were to continue the temperature graphs above, what would you consider its interval, or period, to be?
 - b. Choose either the high or low average temperatures and sketch the graph for three intervals, or periods.
 - c. What function have you graphed that looks similar to this graph?
 3. How do you think New York City's averages would compare to Atlanta's?
 4. Sine and cosine functions can be used to model average temperatures for cities. Based on what you know about these graphs from earlier units, why do you think these functions are more appropriate than a cubic function? Or an exponential function?

5. Use the graph at the beginning of this problem to write the equation that models the average high temperatures in Atlanta from January to December. You can let the independent variable be the number of months since January 1; this means January corresponds to 0, February to 1, etc.

Problem 3: The Ferris Wheel

There are many rides at the amusement park whose movement can be described using trigonometric functions. The Ferris Wheel is a good example of periodic movement.

Sydney wants to ride a Ferris wheel that has a radius of 60 feet and is suspended 10 feet above the ground. The wheel rotates at a rate of 2 revolutions every 6 minutes. (Don't worry about the distance the seat is hanging from the bar.) Let the center of the wheel represent the origin of the axes.

1. Write a function that describes Sydney's height above the ground as a function of the number of seconds since she was $\frac{1}{4}$ of the way around the circle (at the 3 o'clock position).
2. How high is Sydney after 1.25 minutes?
3. Sydney's friend got on after Sydney had been on the Ferris wheel long enough to move a quarter of the way around the circle. How would a graph of her friend's ride compare to the graph of Sydney's ride? What would the equation for Sydney's friend be?



Problem 4: Just Swingin' Around

Suppose Tarzan is swinging back and forth on his grapevine. As he swings, he goes back and forth over the river bank, hovering alternately over land and water. Jane decides to model his motion mathematically and starts her stopwatch.

Let t be the number of seconds the stopwatch reads and let y be the number of meters Tarzan is from the riverbank (not his height). Assume y varies sinusoidally with t and that y is positive when Tarzan is over water and negative when Tarzan is over land.



Jane finds that at 2 seconds, Tarzan is at one end of his swing 23 feet from the riverbank over land. At 5 seconds, Tarzan is at the other end of his swing 17 feet from the riverbank over water.

1. Represent the function with a table. The independent variable is time t (in seconds) and the dependent variable is Tarzan's distance (in meters) from the riverbank. Determine at least 4 values for the table.
2. Sketch a graph of the function. Label the axes and indicate the scale used.
3. Determine the equation to represent Tarzan's distance, y , from the riverbank as a function of time, t .
4. Once you have the equation of the function, answer the questions:
 - a. Where was Tarzan when Jane started her stopwatch?
 - b. How long after Jane started the stopwatch was Tarzan directly over the riverbank?
 - c. How long is Tarzan over water?
 - d. Where will Tarzan be one minute from the time Jane started the stopwatch?

Problem 5: A Steamboat Ride

Mark Twain sat on the deck of a river steamboat. As the paddlewheel turned, a brightly painted yellow dot on the paddle blade moved in such a way that its distance from the water's surface was a sinusoidal function of time.

When the watch read 4 seconds, the dot was at its highest point, 16 feet above the water's surface. The wheel's diameter was 18 feet and it completed a revolution every 10 seconds.



1. Represent the function with a table. The independent variable is time t (in seconds) and the dependent variable is the distance of the dot (in feet) from the water's surface (a negative value for the dependent variable implies the notch is underwater). Determine at least 4 values for the table.
2. Sketch a graph of the function. Label the axes and indicate the scale used.
3. Determine an equation that models the distance, d , of the dot from the water's surface as a function of time, t .
4. After you have the equation of the function, answer these questions:
 - a. How far above the surface was the dot when Mark's stopwatch read 5 seconds?
 - b. How long was the dot below the water's surface?
 - c. From the time when the stopwatch was started, when was the first time that the dot was at the surface of the water?
 - d. At the time found in part c, was it emerging from or entering the water? How do you know?

Discovering a Pythagorean Identity

Mathematical Goals

- Understand the meaning of an identity
- Use inductive reasoning to conjecture $(\sin t)^2 + (\cos t)^2 = 1$ is true for all real numbers
- Prove $(\sin t)^2 + (\cos t)^2 = 1$ is true for all real numbers

MGSE9-12.F.TF.8 Prove the Pythagorean identity $(\sin A)^2 + (\cos A)^2 = 1$ and use it to find $\sin A$, $\cos A$, or $\tan A$, given $\sin A$, $\cos A$, or $\tan A$, and the quadrant of the angle.

Standards for Mathematical Practice

- Make sense of problems and persevere in solving them.
- Reason abstractly and quantitatively.
- Construct viable arguments and critique the reasoning of others.
- Model with mathematics.
- Use appropriate tools strategically.
- Attend to precision.
- Look for and make use of structure.
- Look for and express regularity in repeated reasoning.

Introduction

Students review the definition of an identity. They use inductive reasoning to conjecture that $(\sin t)^2 + (\cos t)^2 = 1$ is true for all real numbers and then use deductive reasoning to prove the statement is an identity. The identity is then used to solve problems.

Materials

Graphing calculator or some other graphing utility

An **identity** is an equation that is true for all values of the variable for which the expressions in the equation are defined.

1. You are already familiar with some identities. For example, the equation $x^2 - y^2 = (x + y)(x - y)$ is an identity. Let's see what this means.
 - a. Complete the table below by randomly choosing values for x and y and then evaluating the expressions $x^2 - y^2$ and $(x + y)(x - y)$. The first row is completed as an example.

x	y	$x^2 - y^2$	$(x + y)(x - y)$
-----	-----	-------------	------------------

Georgia Department of Education
 Georgia Standards of Excellence Framework
 GSE Pre-Calculus • Unit 1

-3	2	5	5

b. What is the relationship between the numbers in the last two columns of each row?

Any values could be plugged in for x and y, but for all three rows that students complete, as in the example, the numbers in the last two columns should be equal.

Because $x^2 - y^2 = (x + y)(x - y)$ is an identity, this means that the expression $x^2 - y^2$ is ALWAYS equal to the expression $(x + y)(x - y)$ for any values of x and y we choose. In other words, the expression $x^2 - y^2$ is *identical in value* to the expression $(x + y)(x - y)$ for any x and y.

The equation $2(x + 1) = 2x + 2$ is an identity because for any value of x, the expression $2(x + 1)$ has the same value as $2x + 2$. (Using the distributive property it can be shown that $2(x + 1)$ is equivalent to $2x + 2$. As an identity, $2(x + 1) = 2x + 2$ says that “twice one more than a number is always equal to 2 more than twice the number itself.”

Not all equations, however, are identities. For example, the equation $2x = x + 4$ is only true for $x = 4$ so $2x = x + 4$ is not an identity. In fact, you can show $2x = x + 4$ is not an identity by providing a counterexample, a value of x for which the equation does not hold (such as $x = 7$; since twice 7 is not equal to 4 more than 7, we have a counterexample). The equation $\sqrt{x^2} = x$ is not an identity. There are many values of x for which the equation is true, but if x is negative the equation is not true (for example, if $x = -3$, then $\sqrt{(-3)^2} = \sqrt{9} = 3$ rather than the value of x which was -3).

Reinforce to students that if a substituted value of a variable results in a true equation, this does not prove that the equation is an identity. The identity must be true for all values of the variable for which the equation is defined; since there are an infinite number of values for substitution, establishing that an equation is an identity by substitution is impossible.

Some examples of identities for all real numbers a and b are:

- $a + b = b + a$
- $a^0 = 1$ for $a \neq 0$
- $0 \cdot a = a \cdot 0 = 0$

Georgia Department of Education
 Georgia Standards of Excellence Framework
 GSE Pre-Calculus • Unit 1

2. There are several important identities in trigonometry. Let's see if we can discover and make sense of one of these identities. Other identities will be explored in a later unit.
- a. Randomly list four real numbers in the first column of the table. Use your calculator to complete the table.

Comment: You may want to encourage students to list at least one of the special real numbers such as $\frac{\pi}{4}$, $\frac{7\pi}{6}$, π , etc for which the exact values of sine and cosine are known.

Be sure students “square the sine of t” rather than “taking the sine of t².” Show them how to enter this in the calculator correctly.

Real number t	$(\sin t)^2$	$(\cos t)^2$	$(\sin t)^2 + (\cos t)^2$

- b. What observations can you make about the values in your table?

Ask all groups in the class to report on their observations.

- c. Based on your observations, what statement can you make about real number t ?

Use the data from the class to conjecture that $(\sin t)^2 + (\cos t)^2 = 1$ for any real number t . Once students make the conjecture, ask if the equation is an identity. Be sure students understand that even though we showed the equation was true for many values of t , we still have not shown the equation is true for ALL real numbers t ---and this is impossible to do by substitution. We need to use deductive reasoning to prove it is an identity.

- d. Use technology to graph $y = (\sin x)^2 + (\cos x)^2$. What do you observe?

The graph of $y = (\sin x)^2 + (\cos x)^2$ is the horizontal line $y = 1$ since $(\sin x)^2 + (\cos x)^2 = 1$

- e. Using what you know about the equation of the unit circle, the way we pair real numbers to points on the unit circle, and how sine and cosine are defined in terms of the unit circle, give a viable argument for why $(\sin t)^2 + (\cos t)^2 = 1$ for all real numbers t .

The equation of the unit circle is $x^2 + y^2 = 1$. Because of the way we pair real numbers to points on the unit circle, we know for real number t there is an angle in standard position of t radians that intercepts an arc t on the unit circle that has a terminal point $P(x, y)$. The

sine and cosine of real number t is defined in terms of the terminal point of t on the unit circle so we can write the coordinates of point P as $(\cos t, \sin t)$. Thus, if we replace x and y in $x^2 + y^2 = 1$ with $\cos t$ and $\sin t$, respectively, we get $(\cos t)^2 + (\sin t)^2 = 1$ or, of course, $(\sin t)^2 + (\cos t)^2 = 1$.

EXAMPLE: The identity $(\sin t)^2 + (\cos t)^2 = 1$ is referred to as a Pythagorean Identity. Let's see how it can be used to answer the following question:

Suppose $\cos t = \frac{1}{2}$. What is the exact value of $\sin t$ if t terminates in the first quadrant?

We can find the answer with the following strategy:

For any real number t , $(\sin t)^2 + (\cos t)^2 = 1$.

Since $\cos t = \frac{1}{2}$ we have $(\sin t)^2 + \left(\frac{1}{2}\right)^2 = 1$.

Therefore, $(\sin t)^2 = \frac{3}{4}$ Why?

$\sin t = \pm \frac{\sqrt{3}}{2}$ Why?

Since t terminates in Quadrant I, then $\sin t > 0$. Therefore, $\sin t = \frac{\sqrt{3}}{2}$.

Now that we know $\sin t = \frac{\sqrt{3}}{2}$ and $\cos t = \frac{1}{2}$, what is the value of $\tan t$?

$$\tan t = \frac{\sin t}{\cos t} = \frac{\frac{\sqrt{3}}{2}}{\frac{1}{2}} = \sqrt{3}$$

3. Use the strategy outlined in the above example to answer the following questions.

a. $\sin t = \frac{1}{3}$ and t terminates in Quadrant 2. What are the exact values of $\cos t$ and $\tan t$?

$$\cos t = -\frac{\sqrt{8}}{9} = \frac{-2\sqrt{2}}{3} \quad \tan t = -\frac{1}{2\sqrt{2}} \text{ or } -\frac{\sqrt{2}}{4}$$

b. $\cos t = \frac{-\sqrt{3}}{5}$ and t is in the 3rd quadrant. What are the exact values of $\sin t$ and $\tan t$?

$$\sin t = -\frac{\sqrt{22}}{5} \quad \tan t = \sqrt{\frac{22}{3}} \text{ or } \frac{\sqrt{66}}{3}$$

Discovering a Pythagorean Identity

An **identity** is an equation that is true for all values of the variable for which the expressions in the equation are defined.

1. You are already familiar with some identities. For example, the equation $x^2 - y^2 = (x + y)(x - y)$ is an identity. Let's see what this means.

a. Complete the table below by randomly choosing values for x and y and then evaluating the expressions $x^2 - y^2$ and $(x + y)(x - y)$. The first row is completed as an example.

x	y	$x^2 - y^2$	$(x + y)(x - y)$
-3	2	5	5

b. What is the relationship between the numbers in the last two columns of each row?

Because $x^2 - y^2 = (x + y)(x - y)$ is an identity, this means that the expression $x^2 - y^2$ is ALWAYS equal to the expression $(x + y)(x - y)$ for any values of x and y we choose. In other words, the expression $x^2 - y^2$ is *identical in value* to the expression $(x + y)(x - y)$ for any x and y .

The equation $2(x + 1) = 2x + 2$ is an identity because for any value of x , the expression $2(x + 1)$ has the same value as $2x + 2$. (Using the distributive property it can be shown that $2(x + 1)$ is equivalent to $2x + 2$. As an identity, $2(x + 1) = 2x + 2$ says that “twice one more than a number is always equal to 2 more than twice the number itself.”

Not all equations, however, are identities. For example, the equation $2x = x + 4$ is only true for $x = 4$ so $2x = x + 4$ is not an identity. In fact, you can show $2x = x + 4$ is not an identity by providing a counterexample, a value of x for which the equation does not hold (such as $x = 7$; since twice 7 is not equal to 4 more than 7, we have a counterexample). The equation $\sqrt{x^2} = x$ is not an identity. There are many values of x for which the equation is true, but if x is negative the equation is not true (for example, if $x = -3$, then $\sqrt{(-3)^2} = \sqrt{9} = 3$ rather than the value of x which was -3).

Some examples of identities for all real numbers a and b are:

Georgia Department of Education
 Georgia Standards of Excellence Framework
GSE Pre-Calculus • Unit 1

- $a + b = b + a$
- $a^0 = 1$ for $a \neq 0$
- $0 \cdot a = a \cdot 0 = 0$

2. There are several important identities in trigonometry. Let's see if we can discover and make sense of one of these identities. Other identities will be explored in a later unit.

- a. Randomly list four real numbers in the first column of the table. Use your calculator to complete the table.

Real number t	$(\sin t)^2$	$(\cos t)^2$	$(\sin t)^2 + (\cos t)^2$

- b. What observations can you make about the values in your table?
- c. Based on your observations, what statement can you make about real number t ?
- d. Use technology to graph $y = (\sin x)^2 + (\cos x)^2$. What do you observe?
- e. Using what you know about the equation of the unit circle, the way we pair real numbers to points on the unit circle, and how sine and cosine are defined in terms of the unit circle, give a viable argument for why $(\sin t)^2 + (\cos t)^2 = 1$ for all real numbers t .

EXAMPLE: The identity $(\sin t)^2 + (\cos t)^2 = 1$ is referred to as a Pythagorean Identity. Let's see how it can be used to answer the following question:

Suppose $\cos t = \frac{1}{2}$. What is the exact value of $\sin t$ if t terminates in the first quadrant?

We can find the answer with the following strategy:

For any real number t , $(\sin t)^2 + (\cos t)^2 = 1$.

Since $\cos t = \frac{1}{2}$ we have $(\sin t)^2 + \left(\frac{1}{2}\right)^2 = 1$.

Therefore, $(\sin t)^2 = \frac{3}{4}$ Why?

Georgia Department of Education
Georgia Standards of Excellence Framework
GSE Pre-Calculus • Unit 1

$$\sin t = \pm \frac{\sqrt{3}}{2} \quad \text{Why?}$$

Since t terminates in Quadrant I, then $\sin t > 0$. Therefore, $\sin t = \frac{\sqrt{3}}{2}$.

Now that we know $\sin t = \frac{\sqrt{3}}{2}$ and $\cos t = \frac{1}{2}$, what is the value of $\tan t$?

3. Use the strategy outlined in the above example to answer the following questions.
- a. $\sin t = \frac{1}{3}$ and t terminates in Quadrant 2. What are the exact values of $\cos t$ and $\tan t$?

 - b. $\cos t = \frac{-\sqrt{3}}{5}$ and t is in the 3rd quadrant. What are the exact values of $\sin t$ and $\tan t$?

Culminating Task: Graphing Other Trigonometric Functions

Mathematical Goals

- Graph the tangent, cosecant, secant, and cotangent functions
- Identify the characteristics of these four functions
- Use the graphs of the sine and cosine functions to make sense of the graphs of these four functions

Georgia Standards of Excellence

MGSE9-12.F.IF.7 Graph functions expressed algebraically and show key features of the graph both by hand and by using technology.

MGSE9-12.F.IF.7e Graph ~~exponential and logarithmic functions, showing intercepts and end behavior, and~~ trigonometric functions, showing period, midline, and amplitude.

Standards for Mathematical Practice

- Make sense of problems and persevere in solving them.
- Reason abstractly and quantitatively.
- Construct viable arguments and critique the reasoning of others.
- Model with mathematics.
- Use appropriate tools strategically.
- Attend to precision.
- Look for and make use of structure.
- Look for and express regularity in repeated reasoning.

Introduction

Students explore the tangent, cosecant, secant, and cotangent functions and their graphs and relate them to the work they have done with the sine and cosine functions.

Materials

Graphing calculator or some other graphing utility

Georgia Department of Education
 Georgia Standards of Excellence Framework
 GSE Pre-Calculus • Unit 1

You have spent time working with sine and cosine graphs and equations. You will now have a chance to move beyond those functions into related functions.

Part A: Exploring the Graphs of $y = \tan(x)$ and $y = \cot(x)$

1. Use your understanding of the unit circle and $\tan t = \frac{\sin t}{\cos t}$ to complete the chart below for the indicated real numbers.

t	$\sin t$	$\cos t$	$\tan t$	$\cot t$
$\frac{\pi}{6}$	$\frac{1}{2}$	$\frac{\sqrt{3}}{2}$	$\frac{\sqrt{3}}{3}$	$\sqrt{3}$
$\frac{\pi}{4}$	$\frac{\sqrt{2}}{2}$	$\frac{\sqrt{2}}{2}$	1	1
$\frac{\pi}{3}$	$\frac{\sqrt{3}}{2}$	$\frac{1}{2}$	$\sqrt{3}$	$\frac{\sqrt{3}}{3}$

What is the value of $\tan t$ if $t = 0$? What is the value of $\tan t$ if $t = \frac{\pi}{2}$? Explain.

2. Complete the chart below using exact values. Remember, $\tan t = \frac{\sin t}{\cos t}$.

3.

t	$-\frac{3\pi}{2}$	$-\frac{5\pi}{4}$	$-\pi$	$-\frac{3\pi}{4}$	$-\frac{\pi}{2}$	$-\frac{\pi}{4}$	0	$\frac{\pi}{4}$	$\frac{\pi}{2}$	$\frac{3\pi}{4}$	π	$\frac{5\pi}{4}$	$\frac{3\pi}{2}$
$\tan t$	<i>Undefined</i>	<i>-1</i>	<i>0</i>	<i>1</i>	<i>Undefined</i>	<i>-1</i>	<i>0</i>	<i>1</i>	<i>Undefined</i>	<i>-1</i>	<i>0</i>	<i>1</i>	<i>undefined</i>

Because $\frac{\pi}{2}$ is an irrational number, it is represented by a non-terminating, non-repeating decimal;

$\frac{\pi}{2} = 1.570796326\dots$. Use your calculator to evaluate the tangent of real numbers as t approaches $\frac{\pi}{2}$

from both the left and right. Use the values in the table. Begin with 1.57 on the left and find the $\tan(1.57)$. Record your answer. Then go in the direction of the red arrow on the left, find the tangent

value of the next four values of t . Notice that each of these values for t is less than $\frac{\pi}{2}$ but each one

is slightly larger than the value of t to its left; in other words, we are “closing in” on $\frac{\pi}{2}$ from the left!

Now we want to close in on $\frac{\pi}{2}$ from the right. Begin with $t = 1.58$ and find its tangent value.

Go in the direction of the red arrow on the right, finding the tangent of these values of t . Record the

Georgia Department of Education
 Georgia Standards of Excellence Framework
GSE Pre-Calculus • Unit 1

tangent values in the table. Notice that as you go from 1.58 to 1.571 to 1.5708 to 1.570797, each of these values is greater than $\frac{\pi}{2}$ but they are “closing in” on $\frac{\pi}{2}$ from the right.

t	1.57	1.5707	1.57079	1.570796	$\frac{\pi}{2} = 1.570796326\dots$	1.570797	1.5708	1.571	1.58
$\tan t$									

Use the information in the two tables of question 2 to sketch the graph of $y = \tan t$ to the best of your ability. What do you think is happening close to $t = -\frac{3\pi}{2}$? What about close to $t = -\frac{\pi}{2}$? What about close to the other values where $\tan t$ is undefined?

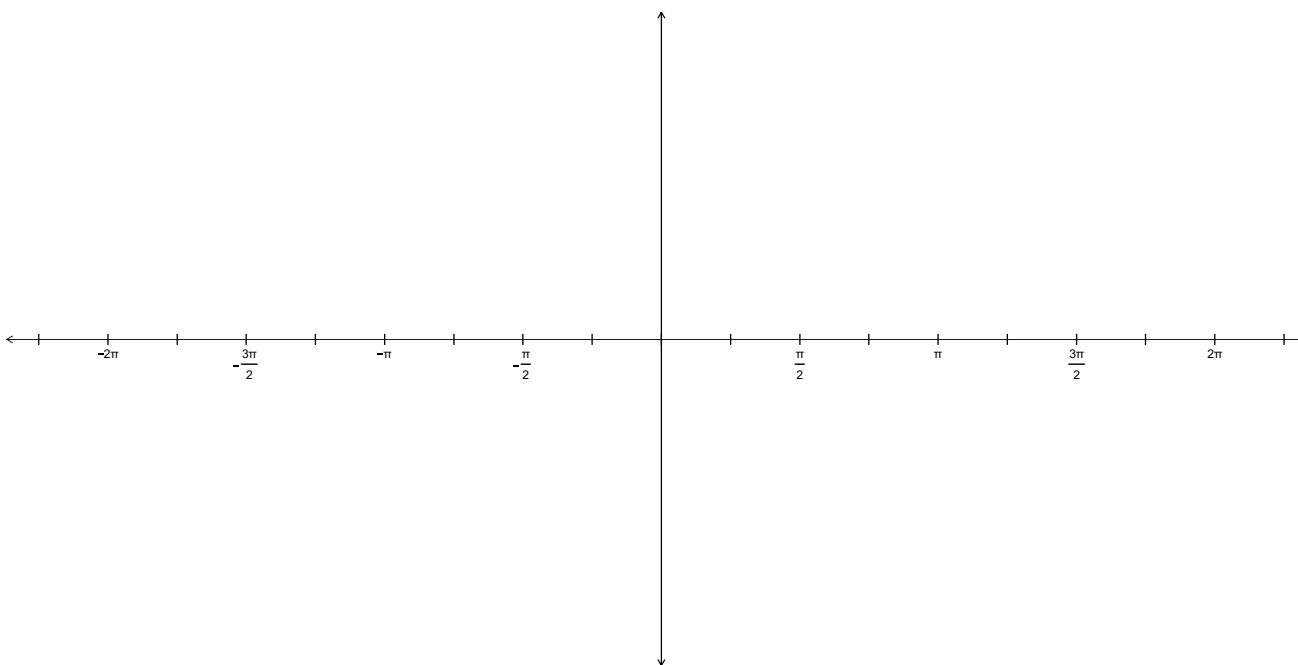

After sketching the graph using the table values, check your sketch by graphing $y = \tan x$ using technology. What do you notice about the graph?

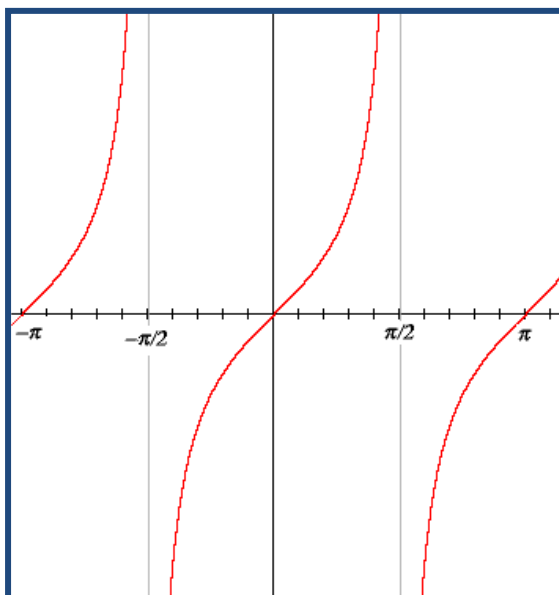

4. Use your graph to answer the following questions.
- What is the period?

The period is π .

- What are the domain and range?

*The domain is the set of real numbers except $x = \frac{\pi}{2}n$, where n is an odd integer.
The range is the set of all real numbers.*

- What is the y-intercept?

The y-intercept is 0.

- Where do the x-intercepts occur?

The x-intercepts are found at πn , where n is an integer.

- Does the graph have any maximum or minimum values? If so, what are they?

There are no minimum or maximum values.

- Does the graph have any asymptotes? If so, where are they?

The asymptotes are found at $x = \frac{\pi}{2}n$, where n is an odd integer.

5. **The cotangent is the reciprocal of the tangent.** So $\cot t = \frac{1}{\tan t}$. Using this definition, extend the table in question 2 by adding cot in the blank column beside tan and filling in the values.

What do you notice about the values of the tangent and cotangent values in the chart?

Answers will vary.

6. Complete the chart below and then graph the cotangent on the given grid.

t	$-\pi$	$-\frac{3\pi}{4}$	$-\frac{\pi}{2}$	$-\frac{\pi}{4}$	0	$\frac{\pi}{4}$	$\frac{\pi}{2}$	$\frac{3\pi}{4}$	π
$\cot t$	<i>Undefined</i>	<i>1</i>	<i>0</i>	<i>-1</i>	<i>Undefined</i>	<i>1</i>	<i>0</i>	<i>-1</i>	<i>Undefined</i>

7. Make a prediction about the graph of $y = \cot t$ and sketch below. As you did with $\tan t$, determine what is happening at the values of t where $\cot t$ is undefined.

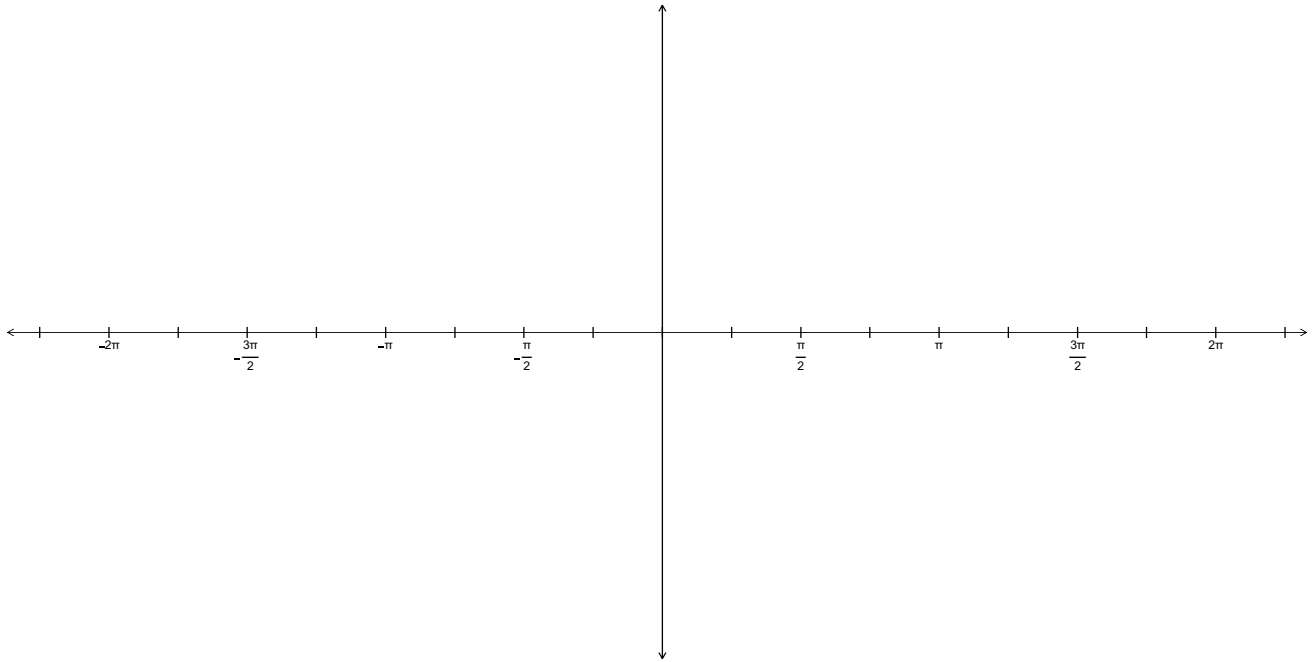

8. Now use technology to graph $y = \cot x$. (You may need to graph $y = \frac{1}{\tan x}$.)

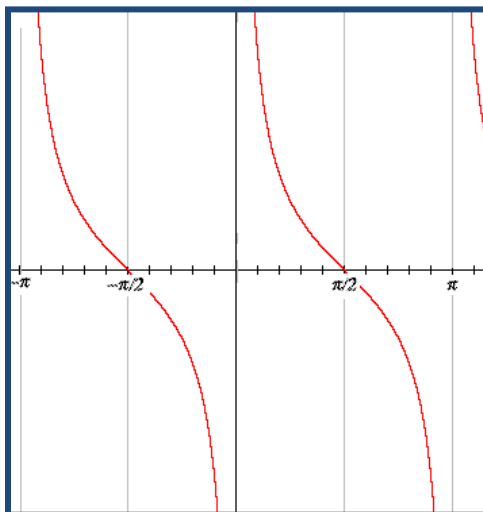

9. Use your graph to answer the following questions.
- What is the period?

The period is π .

- What are the domain and range?

*The domain is the set of real numbers except $x = \pi n$, where n is an integer.
The range is the set of all real numbers.*

- What is the y-intercept?

There is no y-intercept.

- Where do the x-intercepts occur?

The x-intercepts are found at $\frac{\pi}{2}n$, where n is an odd integer.

- Does the graph have any maximum or minimum values? If so, what are they?

There are no minimum or maximum values.

- Does the graph have any asymptotes? If so, where are they?

The asymptotes are found at $x = \pi n$, where n is an integer.

10. Compare the graphs of $y = \tan t$ and $y = \cot t$. How are the graphs alike? How are they different?

Encourage students to discuss the shapes of the graphs. They should also notice the functions have the same range but the domains are different. Where $y = \tan t$ has x-intercepts, $y = \cot t$. Similarly, where $y = \cot t$ has x-intercepts, $y = \tan t$ has asymptotes. Where the value of one function is close to zero, the value of the other function is infinitely large. Encourage students to discuss the relationship between a number and its reciprocal to make sense of these differences.

Part B: Exploring the Graphs of $y = \csc(x)$ and $y = \sec(x)$

The cosecant and secant functions are reciprocals of the sine and cosine functions. The cosecant, \csc , is the reciprocal of the sine function. The secant, \sec , function is the reciprocal of the cosine function.

$$\csc t = \frac{1}{\sin t} \qquad \sec t = \frac{1}{\cos t}$$

These graphs will be explored using a graphing calculator.

11. Graph $y = \sin x$ and $y = \csc x$ over $[-2\pi, 2\pi]$. (You will need to graph $y = \frac{1}{\sin x}$ for $y = \csc x$.

)

a. What are the values of $\sin x$ at $x = -2\pi, -\pi, 0, \pi,$ and 2π ?

The value of sine at those angles is 0.

b. What are the values of $\csc x$ at $x = -2\pi, -\pi, 0, \pi,$ and 2π ? Why?

The graph doesn't show any values of cosecant for these real numbers since $1/0$ is undefined. Since the cosecant is the reciprocal of the sine, when the sine value is close to zero, the cosecant is infinitely large or infinitely small—this creates an asymptote at these real numbers.

c. What are the values of x where the graph of $y = \sin x$ is tangent to the graph of $y = \csc x$?

The graphs are tangent when the value of both functions is 1 or -1. This occurs at multiples of $\frac{\pi}{2}$.

Answer the following questions for $y = \csc x$.

d. What is the period?

The period is 2π

e. What are the domain and range?

The domain is the set of real numbers except $x = n$ where n is an integer. The range is the set of all real numbers greater than or equal to 1 or less than or equal to -1

Georgia Department of Education
Georgia Standards of Excellence Framework
GSE Pre-Calculus • Unit 1

f. What is the y-intercept?

There is no y-intercept.

g. Where do the x-intercepts occur?

There are no x-intercepts.

h. Does the graph have any maximum or minimum values? If so, what are they?

There are relative minimums and relative maximums but no global minimum or maximum values.

$y=1$ is a relative minimum when $x = \frac{\pi}{2} + 2n\pi$ where n is an integer.

$y=-1$ is a relative maximum when $x = \frac{3\pi}{2} + 2n\pi$, where n is an integer.

i. Does the graph have any asymptotes? If so, where are they?

The asymptotes are found at $x = n\pi$ where n is an integer.

12. Graph $y = \cos x$ and $y = \sec x$ over $[-2\pi, 2\pi]$.

(You may need to graph $y = \frac{1}{\cos x}$ for $y = \sec x$.)

a. What are the values of $\cos x$ at $x = -3\pi/2, -\pi/2, \pi/2,$ and $3\pi/2$?

The value of cosine at those angles is 0.

b. What are the values of $\sec x$ at $x = -3\pi/2, -\pi/2, \pi/2,$ and $3\pi/2$? Why?

The graph doesn't show any values of secant for these angles. $1/0$ is undefined. Since the secant is the reciprocal of the cosine, when the cosine value is close to zero, the secant is infinitely large or infinitely small—this creates an asymptote at these real numbers.

c. What are the values of x where the graph of $y = \cos x$ is tangent to the graph of $y = \sec x$?

The graphs are tangent when the value of both functions is 1 or -1. This occurs at multiples of π .

Answer the following questions for $y = \sec x$.

d. What is the period?

The period is 2π .

e. What is the domain and range?

The domain is the set of real numbers except $x = \frac{n\pi}{2}$ where n is an odd integer.

The range is the set of all real numbers greater than or equal to 1 or less than or equal to -1.

f. What is the y-intercept?

The y-intercept is 1.

g. Where do the x-intercepts occur?

There are no x-intercepts.

h. Does the graph have any maximum or minimum values? If so, what are they?

There are relative minimums and relative maximums but no global minimum or maximum values.

$y=1$ is a relative minimum when $x = n\pi$ where n is an even integer.

$y=-1$ is a relative maximum when $x = n\pi$ where n is an odd integer.

i. Does the graph have any asymptotes? If so, where are they?

The asymptotes are found at $x = \frac{n\pi}{2}$ where n is an odd integer.

13. Which of the following functions have periods of 2π ? Which have periods of π ?

$y = \sin x$, $y = \cos x$, $y = \tan x$, $y = \cot x$, $y = \csc x$, $y = \sec x$

Sine, cosine, cosecant and secant have period of 2π .

Tangent and cotangent have periods of π .

14. The transformations of the tangent, cotangent, secant, and cosecant functions work the same way as the transformations of the sine and cosine. The only difference is the period of the tangent and cotangent.

The **period** of functions $y = \sin (bx)$, $y = \cos (bx)$, $y = \csc (bx)$, $y = \sec (bx)$ is $\frac{2\pi}{b}$ for $b > 0$.

The **period** of functions $y = \tan (bx)$, and $y = \cot (bx)$ is $\frac{\pi}{b}$ for $b > 0$.

Georgia Department of Education
Georgia Standards of Excellence Framework
GSE Pre-Calculus • Unit 1

15. Write an equation for the indicated function given the period, phase shift and vertical translation.
- a. Tangent function: period = 2π

Since the period is $\frac{\pi}{b}$ then $\frac{\pi}{b} = 2\pi$. Therefore, $b = \frac{1}{2}$.

$$y = \tan\left(\frac{1}{2}x\right)$$

- b. Tangent function: phase shift of $\frac{\pi}{6}$ to the right.

$$y = \tan\left(x - \frac{\pi}{6}\right)$$

16. Graph the following functions using technology. Discuss what kind of transformations for the parent graph are expected and confirm the graph supports these expectations.

a. $y = \tan\left(x - \frac{\pi}{4}\right) + 2$

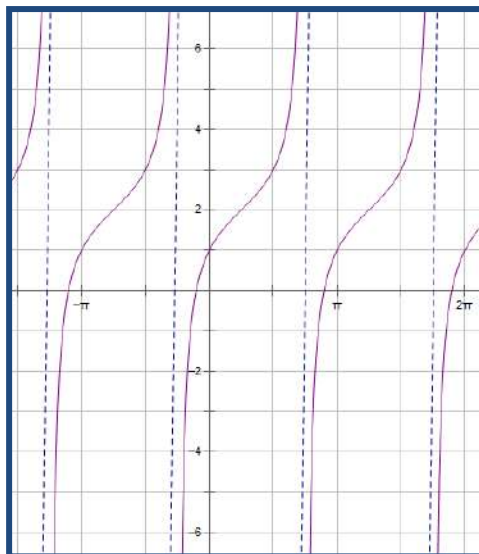

Georgia Department of Education
 Georgia Standards of Excellence Framework
 GSE Pre-Calculus • Unit 1

b. $y = \cot\left[2\left(x - \frac{\pi}{4}\right)\right]$

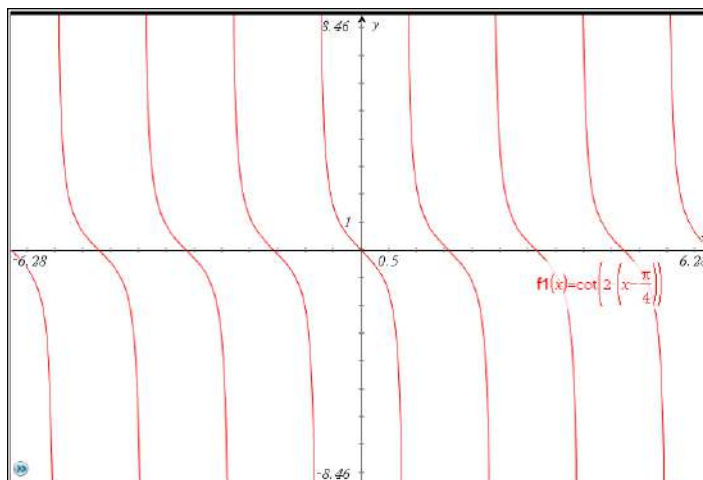

- c. Use technology to graph $y = \sec\left[2\left(x + \frac{\pi}{4}\right)\right]$ and $y = \cos\left[2\left(x + \frac{\pi}{4}\right)\right]$. Graph both on the same set of axes so you can compare their graphs. How is the reciprocal relationship between the secant and cosine functions illustrated on the graphs?

$y = \sec\left[2\left(x + \frac{\pi}{4}\right)\right]$ is graphed in red. $y = \cos\left[2\left(x + \frac{\pi}{4}\right)\right]$ is graphed in green.

Where the cosine function is close to zero, the secant function is infinitely large or infinitely small. Where the cosine function is zero, the secant function is not defined.

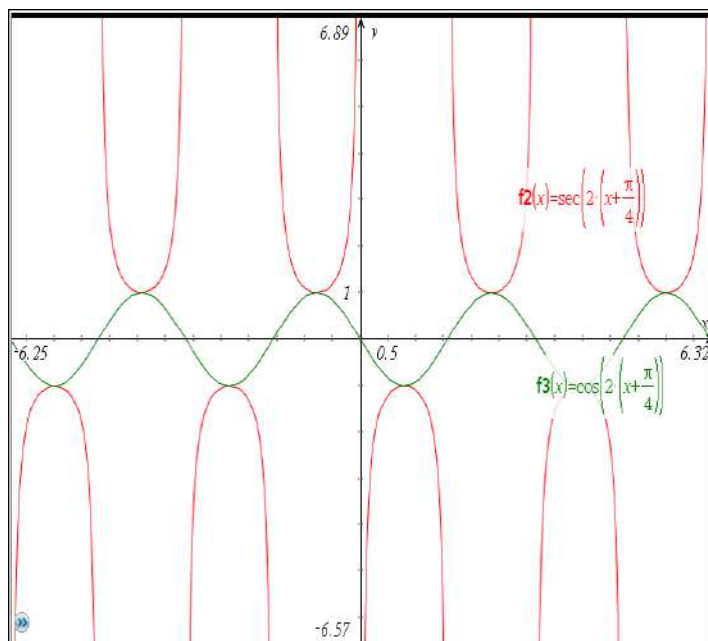

Graphing Other Trigonometric Functions

You have spent time working with sine and cosine graphs and equations. You will now have a chance to move beyond those functions into related functions.

Part A: Exploring the Graphs of $y = \tan(x)$ and $y = \cot(x)$

1. Use your understanding of the unit circle and $\tan t = \frac{\sin t}{\cos t}$ to complete the chart below for the indicated real numbers.

t	$\sin t$	$\cos t$	$\tan t$	
$\frac{\pi}{6}$				
$\frac{\pi}{4}$				
$\frac{\pi}{3}$				

What is the value of $\tan t$ if $t = 0$? What is the value of $\tan t$ if $t = \frac{\pi}{2}$? Explain.

2. Complete the chart below using exact values. Remember, $\tan t = \frac{\sin t}{\cos t}$.

t	$-\frac{3\pi}{2}$	$-\frac{5\pi}{4}$	$-\pi$	$-\frac{3\pi}{4}$	$-\frac{\pi}{2}$	$-\frac{\pi}{4}$	0	$\frac{\pi}{4}$	$\frac{\pi}{2}$	$\frac{3\pi}{4}$	π	$\frac{5\pi}{4}$	$\frac{3\pi}{2}$
$\tan t$													

Because $\frac{\pi}{2}$ is an irrational number, it is represented by a non-terminating, non-repeating decimal;

$\frac{\pi}{2} = 1.570796326\dots$. Use your calculator to evaluate the tangent of real numbers as t approaches $\frac{\pi}{2}$ from both the left and right. Use the values in the table. Begin with 1.57 on the left and find the $\tan(1.57)$. Record your answer. Then go in the direction of the red arrow on the left, find the tangent value of the next four values of t . Notice that each of these values for t is less than $\frac{\pi}{2}$ but each one is slightly larger than the value of t to its left; in other words, we are “closing in” on $\frac{\pi}{2}$ from the left!

Georgia Department of Education
 Georgia Standards of Excellence Framework
 GSE Pre-Calculus • Unit 1

Now we want to close in on $\frac{\pi}{2}$ from the right. Begin with $t = 1.58$ and find its tangent value.

Go in the direction of the red arrow on the right, finding the tangent of these values of t . Record the tangent values in the table. Notice that as you go from 1.58 to 1.571 to 1.5708 to 1.570797, each of these values is greater than $\frac{\pi}{2}$ but they are “closing in” on $\frac{\pi}{2}$ from the right.

t	1.57	1.5707	1.57079	1.570796	$\frac{\pi}{2} = 1.570796326\dots$	1.570797	1.5708	1.571	1.58
$\tan t$									

Use the information in the two tables of question 2 to sketch the graph of $y = \tan t$ to the best of your ability. What do you think is happening close to $t = -\frac{3\pi}{2}$? What about close to $t = -\frac{\pi}{2}$? What about close to the other values where $\tan t$ is undefined?

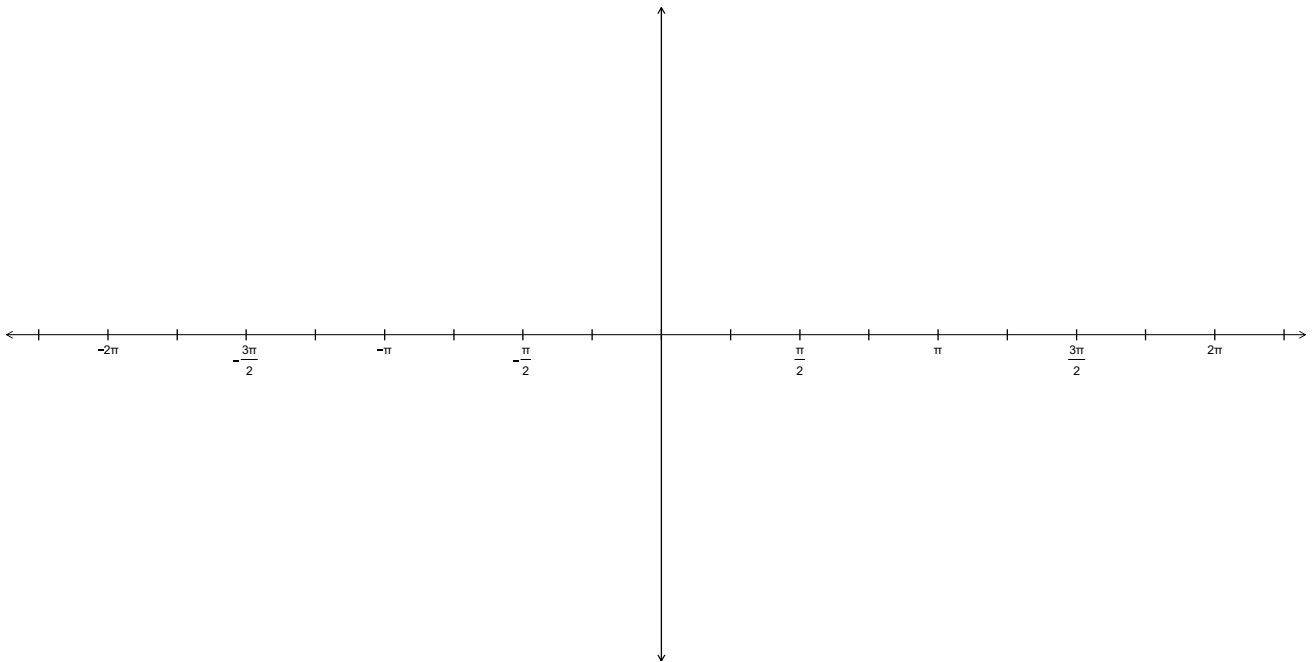

After sketching the graph using the table values, check your sketch by graphing $y = \tan x$ using technology. What do you notice about the graph?

3. Use your graph to answer the following questions.
 - a. What is the period?

Georgia Department of Education
 Georgia Standards of Excellence Framework
GSE Pre-Calculus • Unit 1

- b. What are the domain and range?
- c. What is the y-intercept?
- d. Where do the x-intercepts occur?
- e. Does the graph have any maximum or minimum values? If so, what are they?
- f. Does the graph have any asymptotes? If so, where are they?

4. **The cotangent is the reciprocal of the tangent.** So $\cot t = \frac{1}{\tan t}$. Using this definition, extend the table in question 2 by adding *cot* in the blank column beside *tan* and filling in the values.

What do you notice about the values of the tangent and cotangent values in the chart?

5. Complete the chart below and then graph the cotangent on the given grid.

<i>t</i>	$-\pi$	$-\frac{3\pi}{4}$	$-\frac{\pi}{2}$	$-\frac{\pi}{4}$	0	$\frac{\pi}{4}$	$\frac{\pi}{2}$	$\frac{3\pi}{4}$	π
<i>cot t</i>									

6. Make a prediction about the graph of $y = \cot t$ and sketch below. As you did with $\tan t$, determine what is happening at the values of t where $\cot t$ is undefined.

Georgia Department of Education
Georgia Standards of Excellence Framework
GSE Pre-Calculus • Unit 1

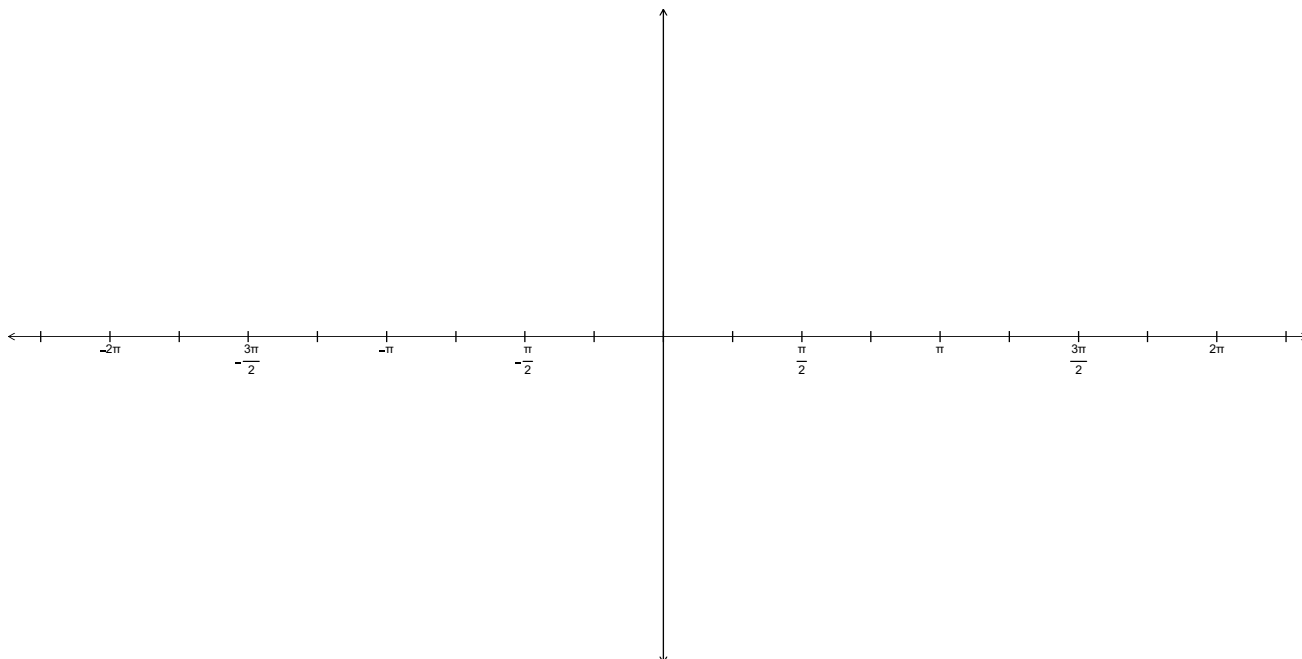

7. Now use technology to graph $y = \cot x$. (You may need to graph $y = \frac{1}{\tan x}$.)
8. Use your graph to answer the following questions.
- What is the period?
 - What are the domain and range?
 - What is the y-intercept?
 - Where do the x-intercepts occur?
 - Does the graph have any maximum or minimum values? If so, what are they?
 - Does the graph have any asymptotes? If so, where are they?
9. Compare the graphs of $y = \tan t$ and $y = \cot t$. How are the graphs alike? How are they different?

Part B: Exploring the Graphs of $y = \csc(x)$ and $y = \sec(x)$

The cosecant and secant functions are reciprocals of the sine and cosine functions. The cosecant, \csc , is the reciprocal of the sine function. The secant, \sec , function is the reciprocal of the cosine function.

$$\csc t = \frac{1}{\sin t} \qquad \sec t = \frac{1}{\cos t}$$

These graphs will be explored using a graphing calculator.

10. Graph $y = \sin x$ and $y = \csc x$ over $[-2\pi, 2\pi]$.

(You may need to graph $y = \frac{1}{\sin x}$ for $y = \csc x$.)

- a. What are the values of $\sin x$ at $x = -2\pi, -\pi, 0, \pi,$ and 2π ?
- b. What are the values of $\csc x$ at $x = -2\pi, -\pi, 0, \pi,$ and 2π ? Why?
- c. What are the values of x where the graph of $y = \sin x$ is tangent to the graph of $y = \csc x$?

Answer the following questions for $y = \csc x$.

- d. What is the period?
- e. What are the domain and range?
- f. What is the y-intercept?
- g. Where do the x-intercepts occur?
- h. Does the graph have any maximum or minimum values? If so, what are they?
- i. Does the graph have any asymptotes? If so, where are they?

11. Graph $y = \cos x$ and $y = \sec x$ over $[-2\pi, 2\pi]$.

Georgia Department of Education
Georgia Standards of Excellence Framework
GSE Pre-Calculus • Unit 1

(You may need to graph $y = \frac{1}{\cos x}$ for $y = \sec x$.)

- a. What are the values of $\cos x$ at $x = -3\pi/2, -\pi/2, \pi/2,$ and $3\pi/2$?
- b. What are the values of $\sec x$ at $x = -3\pi/2, -\pi/2, \pi/2,$ and $3\pi/2$? Why?
- c. What are the values of x where the graph of $y = \cos x$ is tangent to the graph of $y = \sec x$?

Answer the following questions for $y = \sec x$.

- d. What is the period?
 - e. What are the domain and range?
 - f. What is the y -intercept?
 - g. Where do the x -intercepts occur?
 - h. Does the graph have any maximum or minimum values? If so, what are they?
 - i. Does the graph have any asymptotes? If so, where are they?
12. Which of the following functions have periods of 2π ? Which have periods of π ?
 $y = \sin x, y = \cos x, y = \tan x, y = \cot x, y = \csc x, y = \sec x$

Georgia Department of Education
Georgia Standards of Excellence Framework
GSE Pre-Calculus • Unit 1

13. The transformations of the tangent, cotangent, secant, and cosecant functions work the same way as the transformations of the sine and cosine. The only difference is the period of the tangent and cotangent.

The **period** of functions $y = \sin (bx)$, $y = \cos (bx)$, $y = \csc (bx)$, $y = \sec (bx)$ is $\frac{2\pi}{b}$ for $b > 0$.

The **period** of functions $y = \tan (bx)$, and $y = \cot (bx)$ is $\frac{\pi}{b}$ for $b > 0$.

14. Write an equation for the indicated function given the period, phase shift and vertical translation.

a. Tangent function: period = 2π

b. Tangent function: phase shift of $\frac{\pi}{6}$ to the right.

15. Graph the following functions using technology. Discuss what kind of transformations for the parent graph are expected and confirm the graph supports these expectations.

a. $y = \tan\left(x - \frac{\pi}{4}\right) + 2$

b. $y = \cot\left[2\left(x - \frac{\pi}{4}\right)\right]$

- c. Use technology to graph $y = \sec\left[2\left(x + \frac{\pi}{4}\right)\right]$ and $y = \cos\left[2\left(x + \frac{\pi}{4}\right)\right]$. Graph both on the same set of axes so you can compare their graphs. How is the reciprocal relationship between the secant and cosine functions illustrated on the graphs?