

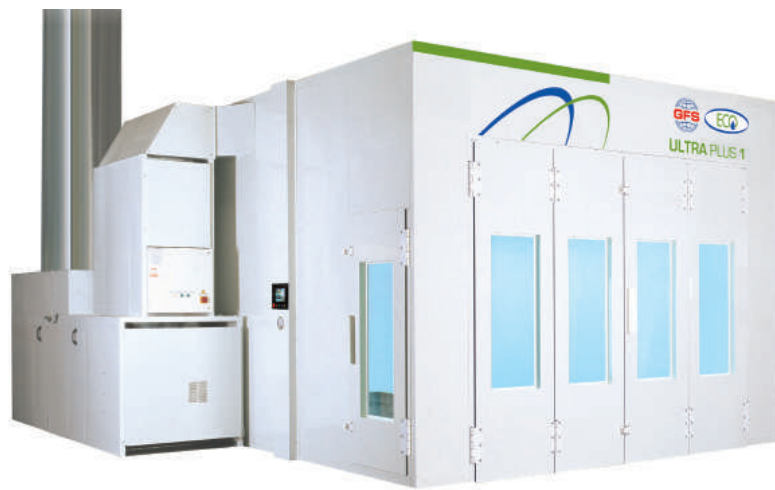

GLOBAL FINISHING SOLUTIONS

## **ULTRA** DOWNDRAFT SPRAY BOOTH CABINS



**OWNERS MANUAL**  
Factory Warranty  
Service & Maintenance  
Contact Information

# Our Thanks



**GLOBAL FINISHING SOLUTIONS**

THE WORLD LEADERS IN PAINT BOOTH TECHNOLOGY

**GFS is proud to be your partner!**

Thank you, and congratulations on choosing GFS! We're confident that your new equipment will help you increase production, save energy, and achieve the best possible finish. After all, we believe that you and your customers deserve nothing less than the best.

That's why GFS continues to be the world leader in paint booths and finishing systems, and has a proud heritage spanning back as far as 1888. By refusing to compromise on quality and performance, and by providing the best support, GFS is committed to the success of our customers, and their satisfaction.

This Owner's Manual is designed to help you get the most from your GFS products. It is essential that you take the time to read the Safety precautions, as they will help to protect against potential hazards. In addition, the maintenance checklist and filter replacement schedule will help you keep your paint booth operating at peak efficiency.

To contact GFS call 1-800-848-8738

Email to [info@globalfinishing.com](mailto:info@globalfinishing.com)

Visit us at [www.globalfinishing.com](http://www.globalfinishing.com)

**THIS EQUIPMENT WAS INSTALLED BY:**

Startup Technician Name: \_\_\_\_\_

Distributor Company Name: \_\_\_\_\_

Distributor Contact Phone: \_\_\_\_\_

Date of Startup: \_\_\_\_\_

# ***Table Of Contents***

---

<b>Safety Precautions.....</b>	<b>4-6</b>
<b>Operation.....</b>	<b>7-12</b>
<b>Maintenance.....</b>	<b>13-14</b>
<b>Filter Replacement Schedule.....</b>	<b>15</b>
<b>Filter Replacement Instructions.....</b>	<b>16</b>
<b>Spray Booth Maintenance Check List.....</b>	<b>17</b>
<b>Parts Replacement.....</b>	<b>18-21</b>
<b>Limited Warranty.....</b>	<b>22</b>
<b>Contact Information.....</b>	<b>23</b>

## Precautions

GFS recommends that only qualified personnel operate and maintain this equipment. All persons who will operate, service, inspect, or otherwise handle this product should read and understand the safe operating practices, safety precautions, and warning messages in this documentation.

Incorrect work practices or inadequate maintenance may cause hazards in or around the spray booth. Everyone working in or around the spray booth should be aware of the possible hazards and carefully follow the safety information.

## Symbol Usage

GFS labels all of its equipment in accordance with the FMC Corporation's Product & Safety Sign & Label System.

The signal words used on our equipment - SAFETY INSTRUCTIONS, CAUTION, and WARNING identify the level of hazard seriousness likely to occur if the warnings are ignored. They also identify the degrees of severity of injury - MINOR INJURY, SEVERE INJURY- and probability of severity- WILL result in .... COULD result in ...

Definitions for identifying hazard levels are provided below, with their respective signal words.

### **WARNING**

*Hazards or unsafe practices, which COULD result in severe personal injury or death.*

### **CAUTION**

*Hazards or unsafe practices, which COULD result in minor personal injury or product or property damage.*

The following safety, caution, and warning labels will be found on your GFS equipment, as well as throughout this literature, wherever possible.

Pay close attention to these symbols; both in reading about the operation and maintenance of your GFS equipment as well as when you are actually operating the equipment.



## Spray Booth Location

The application of paint by spraying must occur in either spray booths or spray areas as described by the National Fire Protection Agency (NFPA) 33, Standard for Spray Application Using Flammable or Combustible Materials. The Ultra spray booth meets the requirements of NFPA 33 for a spray booth. If the Ultra spray booth is located in a building classified as an assembly, educational, institutional, or residential occupancy two specific requirements must be met. First the room where the Ultra spray booth is located must be separated vertically and horizontally by construction having a fire rating of at least two hours. Secondly the room must be protected by an approved automatic fire protection system. The fire protection system must be designed and installed in compliance with NFPA 13.

## Construction & Design

The Ultra spray booth has been designed to comply with the applicable requirements of NFPA 33. Following are specific requirements relating to construction and design that must be met to maintain a safe environment in and around the workstation.

- Any air intake filters used in the spray booth must be listed as Class 1 or Class 2 in accordance with ANSI/UL 900.
- The spray booth must be separated from other operations by at least three feet or a partition, wall, floor, or ceiling that has a minimum fire rating of one hour or more.  
When installed all parts of the spray booth must be accessible for cleaning.
- A clear space of at least three feet must be kept around the spray booth unless it is located next to a partition, internal wall, floor, or ceiling that has a minimum fire rating of one hour or more. The spray booth may be located next to a non-combustible external wall. The partition, wall, floor, or ceiling may not inhibit the maintaining and cleaning of the workstation.
- A powered vehicle must only be moved into the spray booth when spraying has stopped and the intake and exhaust fans are on.

## Ventilation

The intake air and exhaust air systems of the Ultra spray booth are designed to comply with the requirements of NFPA 33. Following are specific requirements that must be met to maintain safe ventilation of the workstation and the building.

- An air make-up unit is required to replace the air exhausted from the building by the Ultra spray booth. The exhaust duct of the workstation must be located so that the discharged air cannot be drawn into any air make-up unit.
- The Ultra spray booth exhaust duct must follow the most direct path to the outside of the building. Keep in mind that the exhaust ductwork cannot pass through a fire wall. The discharge of the exhaust duct must be six feet away from any wall or roof. It is best if the discharge is pointed up with no overhead obstructions. Do not operate the workstation unless exhaust has been ducted properly.
- The access door in the exhaust stack of the spray booth must be accessible to allow for inspection, maintenance, cleaning, and access to the automatic fire protection system.

- The ventilation system of the spray booth must stay on until the paint has dried on the work piece.
- Exhaust ventilation must be kept on at all times during the spray painting, drying and any work involving flammable materials.
- Ventilation and exhaust systems are designed and installed per NFPA 91.
- Isolate the outdoor vent from air-conditioning intakes, windows, and any other equipment that may re-circulate the exhaust indoors.

## Storage

The Ultra spray booth has not been designed to store paints or other combustible liquids. Storage of paints and other combustible liquids in or near a spray area must comply with the requirements of NFPA 33.

## Fire Protection

GFS does not provide fire protection for the Ultra booth but an approved automatic fire protection system must be installed to comply with the requirements of NFPA 33. A licensed fire protection company must design and install a fire protection system that protects the work area, exhaust plenum, exhaust ductwork, and exhaust filters of the Ultra booth.

Sprinklers protecting the spray areas shall be protected from overspray residue so that they will operate quickly in the event of a fire. If covered, cellophane bags having a thickness of 0.003 in (.03076 mm) or less, or thin paper bags shall be used. Sprinklers that have become coated with overspray should be replaced by listed sprinklers of the same characteristics.

## CAUTION

*Portable fire extinguishers need to be provided and located in accordance with NFPA 10.*

## Precautions

Before operating the spray booth read and understand this entire section.

### **WARNING**

*Improper operation of the spray booth may result in a FIRE or EXPLOSION.*

### **CAUTION**

*This equipment is designed expressly for the removal of particulate matter only. Reduction of volatile organic compounds (VOCs) requires either coating reformulation or optional, additional equipment.*

## Operator Safety

Guards and covers that prevent contact with electrically energized or moving parts are required and must not be removed or left open during operation.

Sound pressure levels over 85 decibels may cause damage to your health. Where applicable, use earplugs or take other safety measures to protect yourself.

Use an OSHA-approved paint spray respirator when spraying in the booth.

Natural gas and propane fueled vehicles must have the fuel system emptied prior to being moved into this booth / drying oven.

Do not store material on the roof of the booth. This will inhibit the explosion relief system.

Do not drill, grind, weld, or use any tools which produce a spark inside the spray booth. Electrical devices used inside the spray booth must be approved for a Class 1 Division 1 area.

Food and beverages should not be stored or consumed inside the spray booth.

## Booth Cleanliness

Turn the air heater on before using the spray booth. Ensure that the fans are operating correctly before entering the booth.

Keep the booth free from any items such as: cans, shelves, tools, paper, etc. They collect dirt that can be released during painting.

Sanding or blowing off should never be done inside the spray booth.

Remove all cloths and rags from the spray booth. Oils and resins will be released from inside the spray booth during the curing cycle. This can cause “fish-eye” and “loss of gloss”.

Do not wear overalls or other articles of clothing, which are spotted or stained with paint and/or solvents.

Check the booth pressurization before each job making sure it is in the paint zone. A slightly pressurized environment will provide the best painting environment.

## Modes of operation

The GFS Ultra spray booth is a high efficiency system with four operating cycles. Following is a description of the four operating cycles.

### *Spray Mode*

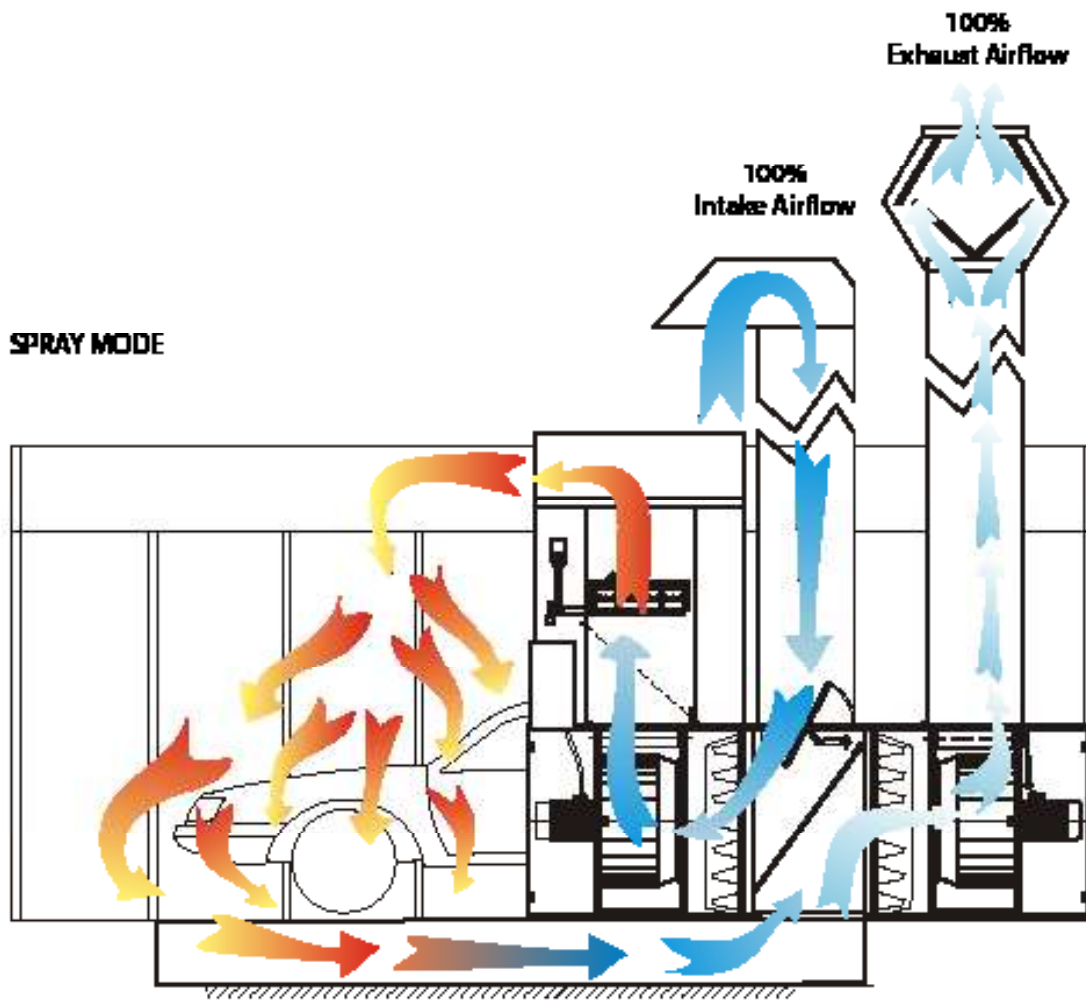

The Spray Mode is the period of time during which the car is moved into the booth, final preparation is conducted and finally the paint is sprayed onto the vehicle.

During this phase, the operator can make minor adjustments to the cabin operating parameters such as temperature etc.

The "Spray" cycle is as follows: Air enters the intake duct and travels through the PRE- filter and to enter the intake blower assembly.



The outside air then passes the direct fire burner and is heated to the pre-set temperature. The air enters into the plenum of the booth where it is pushed through the ceiling filters, which removes particles larger than 10 microns. As the air enters the booth, it is evenly distributed throughout the cabin.

An envelope of air is created around the vehicle as it travels toward the grating in the floor. The pit filter removes the majority of the overspray and allows the air to move through the tunnel and back to the mechanical unit. The air then enters the exhaust side of the mechanical unit and passes through the POST- filters.

The air then travels through the exhaust duct until it reaches the stack head. The stack head prevents rain and foreign objects from entering the duct but at the same time allows the exhaust air to be expelled vertically into the atmosphere outside.

### *Flash Mode*

The "Flash-Off" phase is the period of time between two applications of paint. This time is used to allow the paint to evaporate or release its solvents.

This is an extremely variable phase, which may or may not be necessary, depending upon the type of paint and application method used. The time setting will be determined in each case by the painter and paint supplier. The "Flash-Off" phase is identical in operation as the spray mode except that the lights in the booth will automatically turn off.

## **WARNING**

*During the spraying and flash-off phases, the booth should always be operating with 100% fresh air. DO NOT TURN OFF BOOTH. This is to avoid any possible build-up of solvents in the booth which could reach levels of flammability and/or explosion.*

### *Purge Mode*

The Purge Mode is the period of time between the last application of material and the bake cycle. The purpose of this mode is to remove vapors from the work area before beginning the bake cycle. This mode is identical to the flash-off mode except for the duration. The international fire code requires that the purge mode have a duration of three minutes.

## Bake Mode

The "Bake Mode" is the period of time required for the curing of the paint applied to the vehicle.

During this phase, the control unit maintains the operator's pre-selected temperature (up to 199°F up to 170°F in CANADA) to obtain the standard 140°F surface temperature.

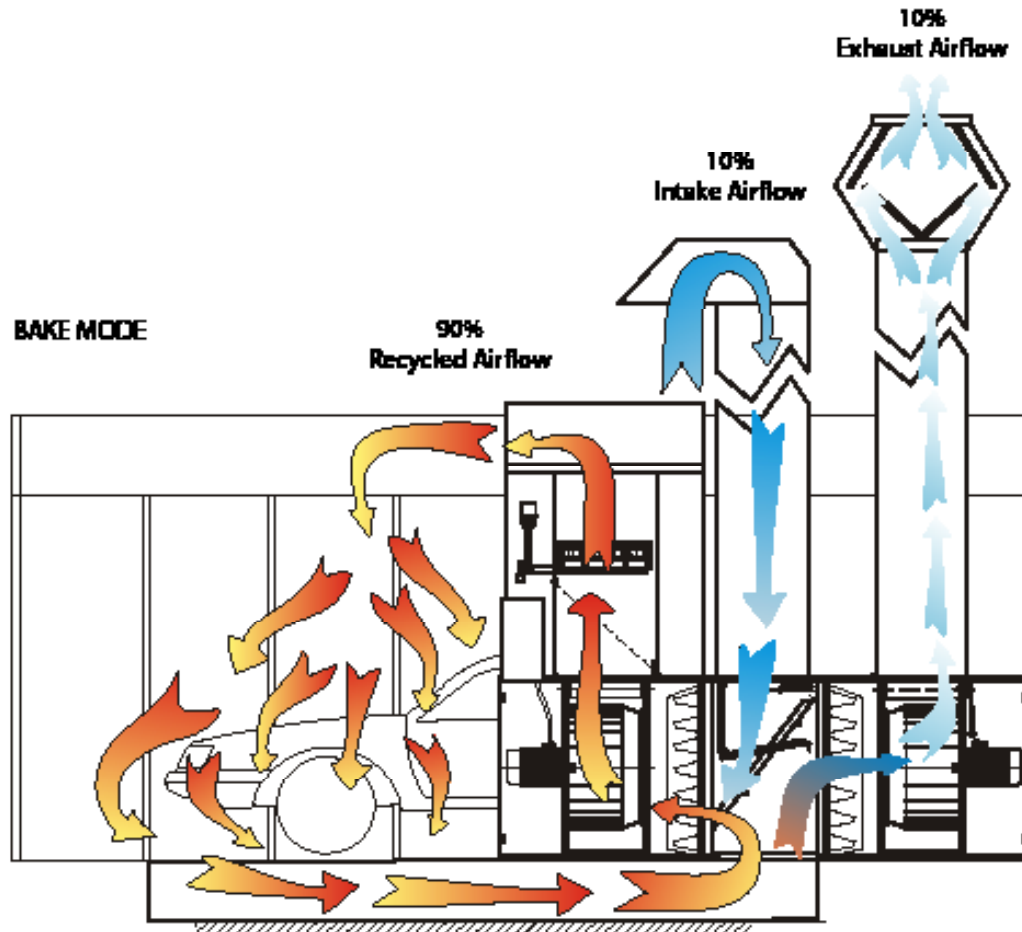

## **⚠ WARNING**

*No one should enter the booth during the "bake mode" and the lights should be off..*

To advance the booth into bake the "SPRAY" to "BAKE" select control button is pushed on the console. The oven timer will begin timing when the booth reaches the pre-set temperature for the bake phase.

The operating cycle is as follows: When the booth is transferred into the bake mode, the controller moves the damper to permit the intake blower assembly to draw a portion (10%) of the air from the outside and re-circulate the remaining (90%).

All the air then passes through the PRE- filter and around the direct fire burner. It is heated to the pre set temperature and enters into the plenum of the booth.

The air fills the plenum and is pushed through the ceiling filters which filter particles larger than 10 microns. The air then enters the booth and is evenly distributed throughout the booth cabin and around the vehicle.

The air is pulled through the pit filters and travels through the tunnel. 90% of the air passes back through the PRE- filters and the heating process.

The other 10% of the air is pulled through the POST- filters and is expelled outside.

## *Cool Down*

The "Cool Down" phase is the period of time required to cool down the heated vehicle and the booth. This phase starts automatically upon completion of the bake period. The operating cycle is similar to the spray mode in that the dampers automatically position themselves to draw 100% fresh air from the outside (See Figure 1).

## **WARNING**

*The red emergency button is used to shut down the booth in an emergency and not to turn the unit off during normal operation. The normal buttons to cycle the booth through the phases would be used.*

## **Safety Features**

Following is a list of safety features that operate automatically during each of the four modes of operation. These features ensure the booth operates reliably and safely.

The maximum booth temperature is controlled by a high limit switch with a fixed temperature setting. This switch will shut down the air heater if the maximum temperature is exceeded. The switch is adjustable from 20°-120°C (85°-240°F). The temperature setting on the high limit switch is preset by the factory technicians during the manufacturing of the air heater.

An electric solenoid valve is installed in the compressed air supply to the spray gun. The solenoid valve allows air to the spray gun when the Spray booth is in Spray Mode, the fans are operating, the light covers are in place, and the doors are closed.

Booth pressure is monitored by a pressure gauge. The gage indicates the pressure in the booth relative to the ambient building pressure. The gauge is used to set the booth balance and when upgraded it can monitor the loading of the filters.

Proximity switches monitor the position of each access door in the spray booth. The proximity door switches enable three functions when all of the doors are closed. First the auto balance is activated, second the spray solenoid is activated, if the all other requirements are met as defined above, and third the bake mode is enabled. If a door is opened during the bake mode then the temperature set point will change to the spray temperature set point.

## Airflow Management

Creating and maintaining the optimal airflow inside a spray booth is of primary importance when refinishing a vehicle. Optimal airflow requires that the variables of air velocity, direction, pressure, and balance are all controlled and stay controlled throughout the life of the spray booth. Following is some information to help you control and maintain your booth for optimal airflow.

The air velocity around the vehicle, when measured at waist height, should be approximately 100 feet per minute (fpm). Variation in air velocity is acceptable as shown in the image below. This air velocity is important as it enables a painter to achieve maximum paint transfer efficiency while keeping overspray and dirt away from the painted finish. This envelope of high speed air around the vehicle is known as the 'spray zone'. The spray zone is shown in the image below. Air velocity can be controlled by speeding up or slowing down the air heater or changing the configuration of the plenum diffuser or pit diffuser trays. If you are having problems with the air velocity in your booth please contact your local GFS distributor.

In a downdraft spray booth the air in the spray zone should flow around the vehicle from the plenum filters to the pit filters. The airflow should be smooth never turbulent. The airflow direction will be different in cross draft, semi-downdraft, and side downdraft booths but it should always be smooth and will flow from the intake filters to the exhaust filters. Turbulent airflow may be the result of excessive air velocity but most likely is the result of the vehicle not being placed in the booth correctly. To develop a smooth 'spray zone' the vehicle must be centered over the pit.

Maintaining the correct air pressure inside the booth is vital to clean paint jobs. Too much positive pressure or negative pressure will make for a dirty booth. The spray zone in an over or under pressurized booth will be compromised and dirt will get into the paint. All enclosed GFS spray booths will automatically adjust the pressure inside the booth as long as the filters are changed according to schedule. In the event that the booth produces dirty paint jobs check the air pressure and filters. If the filters are clean and the booth cannot automatically adjust the pressure contact your local GFS distributor.

Balanced airflow is as important as the velocity of the airflow. Differences in air velocity around the vehicle should be no greater than 20fpm as shown below. Incorrect balancing will lead to uneven temperature and uneven overspray evacuation. The airflow balance can be adjusted by changing the configuration of the plenum diffuser or pit diffuser trays. Call your local GFS distributor if you are having problems with unbalanced airflow.

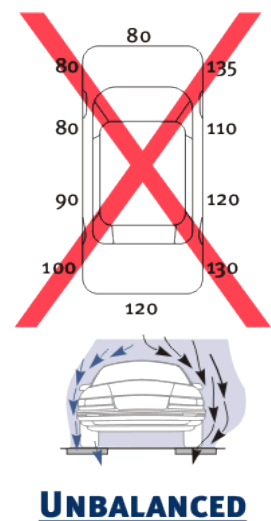
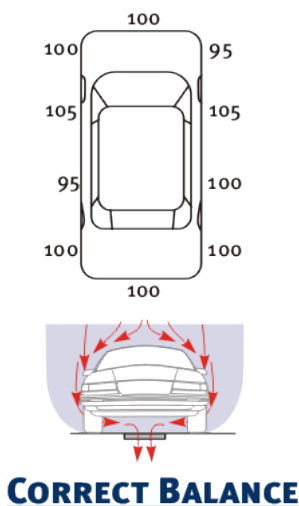
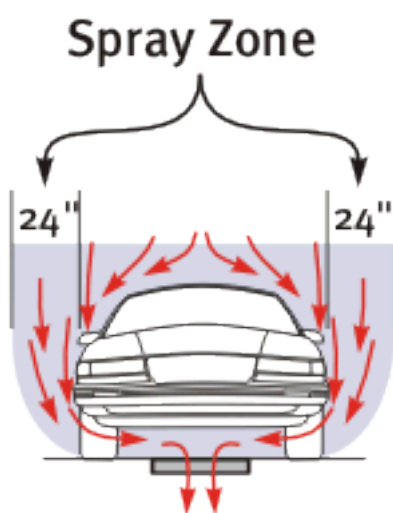

## Precautions

Clean the spray booth at factory recommended intervals. Make sure the plenum, air ducts and exhaust areas are all cleaned. The spray booth is a complete system and should be cleaned accordingly.

### **CAUTION**

#### *Shear Point*

*Keep hands clear of moving parts. Follow lock out procedures before servicing this unit.*

### **CAUTION**

#### *Electrical shock potential*

*Insure proper lockout procedures are followed before servicing this unit.*

### **WARNING**

*A buildup of overspray on the floor, in the ductwork, the heating system, or the pit should be prevented. The overspray may ignite causing a fire or explosion.*

## Signage

Safety signs, panels, and labels that are normally affixed to the product must be replaced immediately if illegible or missing.

New or replacement parts that are installed during repair or maintenance must include all safety signs, panels, and labels as specified by the manufacturer. These must be affixed to the new or replacement parts as specified by the manufacturer.

## Spray Area

The spray area must be kept clean to prevent the accumulation of deposits of combustible materials. Remove any paint residue from the walls. Use a brush to remove loose overspray from the walls then wipe down the walls with a rag using soap and water.

Vacuuming the floor is the best practice. Brooms and mops do not collect all the dirt. Using an industrial grade vacuum cleaner or a central vacuum system, thoroughly clean the booth each working day. If a portable vacuum cleaner is used, keep the unit outside the booth and use a long hose to reach inside the booth. The exhaust from the vacuum contains particulate matter which will remain inside the booth for extended periods of time.

Use a rag with soap and water to thoroughly wipe all air hoses in the booth. Wipe each air hose from end to end. Whenever possible keep air hoses off the floor of the booth.

## Pit

Vacuum out dirt deposited in the pit below the paint arrestor filters when they are being changed. Grating should be removed and pressure washed at regular intervals. Be careful not to fall into the pit while servicing.

## Light Fixtures

GFS recommends using a strippable coating, available from your local distributor. This is a layered plastic laminate that covers the glass only. When using this strippable laminate, remove a layer when the overspray degrades the lighting.

If you do not use a strippable laminate, the use of a rag with soap and water should be used to remove the overspray from the glass. Overspray that does not come off using this method must be removed with a razor blade.

## Filters

**ALWAYS FOLLOW THE GFS RECOMMENDED REPLACEMENT PROGRAM FOR FILTERS.** Use GFS replacement filters for the plenum, the air heater and the pit. GFS filters are designed to provide high efficiency and will maintain balanced airflow during the life of the filter.

The buildup of paint overspray on the pit filters must be monitored. This may be accomplished with a manometer, or an **effective inspection program**. Monitoring is meant to ensure the filters are capturing overspray and do not become overloaded. A manometer may be purchased from GFS (Part # 242-001)

All filters should fit tightly in filter frames. If filters do not make a proper seal with the filter frames, unfiltered air will pass to the next part of the system. Take extreme care to make sure plenum filters are installed properly.

Various weather conditions (smog, fog, and frost) produce atmospheric dust concentrations that are often much higher than during normal weather conditions. Pre-filters and plenum filters may become filled in a short time. Keep a set of replacement filters on hand.

To ensure correct maintenance is being followed have your local authorized and factory trained GFS distributor maintain your refinish system.

Treat used arrestor filter pads and any other paint-contaminated items as flammable products and dispose of them properly and safely.

## Ductwork

Clean overspray from all ductwork as necessary.

## ***Exhaust Filter Replacement***

Replace the pit filters often, 50 to 70 paint jobs. This recommendation is based on a 10 partial to 1 overall ratio. The paint system and individual painter will greatly affect the life of the pit filters.

The buildup of paint overspray on the pit filters must be monitored. This may be accomplished with a manometer, or an **effective inspection program**. Monitoring is meant to ensure the filters are capturing overspray and do not become overloaded. A manometer may be purchased from GFS (Part # 242-001)

**Do not use Fiberglass filters.** These filters do not protect the plenum filters and may lead to premature failure of the exhaust fan.

Downdraft Cabins

Pit	Part Number	Description	Quantity
Single Row, 18'L to 24'L	FIL-ERP-3024-W	Roll Media, 30"W x 24'L	1
Single Row, 27'L	FIL-ERP-3024-W	Roll Media, 30"W x 24'L	2
Two Row, 18' to 24'L	FIL-ERP-3024-W	Roll Media, 30"W x 24'L	2
Two Row, 27'L	FIL-ERP-3024-W	Roll Media, 30"W x 24'L	3
Three Row, 18'L to 24'L	FIL-ERP-3024-W	Roll Media, 30"W x 24'L	3

## ***Plenum Filter Replacement***

Change the plenum filters after 1500-1800 operating hours. Proper maintenance of the booth and correct replacement of the burner pre-filters, and pit filters will affect the life of the plenum filters.

Cabin Dimensions	Part Number(s)	Description	Quantity
24'L x 14'W	FMI27144	Intake Filter, High Temperature, Diffusion media, 27" or 75" wide by 72", 108", or 144" long	4
	FMI75144		2
27'L x 14'W	FMI27108		6
	FMI75108		3
30'L x 14'W	FMI27072		2
	FMI75072		1
	FMI27144	4	
	FMI75144	2	



GLOBAL FINISHING SOLUTIONS

## Exhaust Pit Filter Replacement

To maintain the optimum air-flow, filter media should be monitored and replaced when needed.

**Safety Note:** There are inherent hazards associated with the operation and service of this equipment. For your personal safety, observe all of the safety information. Do not operate the spray booth when filters need to be replaced.

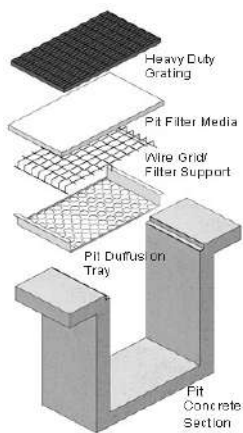

## Instructions

1. Disconnect and lock out the main electrical service before servicing.
2. Remove grating from the floor, using hook bars.
3. Remove used Wave filter media by rolling up into a roll and tying closed. Treat used filters and any other paint-contaminated items as flammable products and dispose of them properly and safely.
4. Roll out the new Wave filter media, and align on wire grid filter support, Wave convoluted-side up.
5. Check to ensure the Wave filter media provides a seal around the entire perimeter of the exhaust pit.
6. Replace grating back onto floor.



### Average Performance Data

Removal Efficiency..... 99.67%  
 Holding Capacity ..... 7 lbs  
 Run Off..... 308 grams  
 Penetration..... 12.3 grams  
 Pressure Drop (initial/final)..... 0.12"/0.50" w.c.  
 Flammability Rating UL Class II (US & Canada certified)  
 Test Lab, LMS Technologies. Complete test report available upon request

### SAFETY HAZARD!

Improper disposal of used filter(s) may cause spontaneous combustion.

You must consult local authorities for proper storage and disposal requirements. The following are some safety guidelines:

- > Immediately remove all used filters from the booth.
- > Discard used filters to a safe, well-detached location to prevent a possible fire hazard.
- > Disposal varies depending on the type of paint that is being captured, consult local authorities.

GFS Part Number:  
**FIL-ERP-3024**  
 30" x 24' Roll

Quantity for  
 Complete Filter Change  
 per Booth:

3



Spray Booth Maintenance Task	Daily	Weekly	Quarter	Semi-Annual	Annual	As Required
Clean / wipe down air hoses *	X					
Vacuum interior of spray booth *		X				
Wipe interior of spray booth walls *		X				
Clean light fixture glass*			X			
Vacuum pit and tunnel			X			
Clean and remove overspray from floor			X			
Check motor belts (BT & Expert groups)			X			
Pressure wash floor grates			X			
Inspect door seals (replace when required)			X			
Check and tighten all electrical connections			X			
Service airflow switches			X			
Lubricate door hinges				X		
Pressure wash spray booth				X		
Lubricate blower shaft bearings (Expert group)				X		
Calibrate booth pressure balancing gauge				X		
Fire suppression system				X		
Clean light tubes					X	
Check light fixture glass seals					X	
Clean inside of all light fixtures and glass					X	
Clean exhaust stack, dampers and stackhead					X	
Clean main exhaust blower / fan					X	
Burner system tune-up (start-up procedure)					X	
Clean upper plenum					X	
Lubricate motors					X	
Door seal / gasket replacement						X
Door hinge brass bushing replacement						X
Replace light tubes and ballasts						X

ITEM	PART NUMBER	DESCRIPTION	REV
1	DH2555	DOOR HANDLE WHITE	01
2	LL0106	LOCKING ROD LEVER	01
3	LR7551	LOCKING ROD	01
4	LRP824	LOCKING ROD PIN	01
5	BF620	6MM-1.00 x 20MM FLAT HEAD PHILLIPS	01
6	SN07	SNAP RING - 7MM	01
7	RE1252	ROD EYELET	01

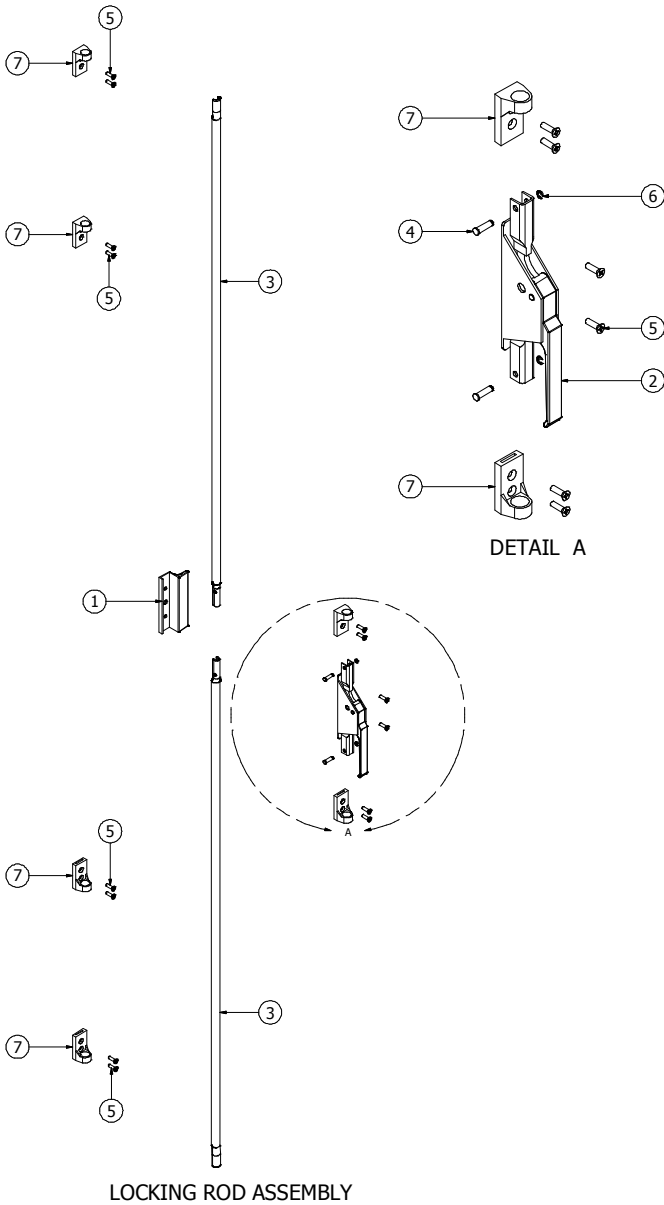

ITEM	PART NUMBER	DESCRIPTION	REV
1	CH2211	TWO KNUCKLE CENTER LEAF HINGE	01
2	CH3211	THREE KNUCKLE CENTER LEAF HINGE	01
3	HP62511	HINGE PIN	01
4	SN12	SNAP RING	01
5	BB163	BRASS BUSHING	01

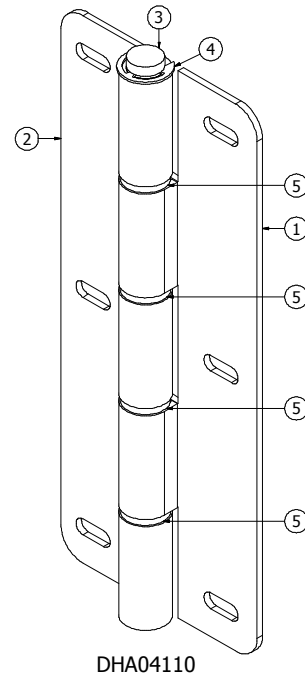

ITEM	PART NUMBER	DESCRIPTION	REV
1	PH2311	PERIMETER HINGE LEAF 2 KNUCKLE	01
2	PH37511	PERIMETER HINGE LEAF 3 KNUCKLE	01
3	HP62511	HINGE PIN	01
4	SN12	SNAP RING	01
5	BB163	BRASS BUSHING	01

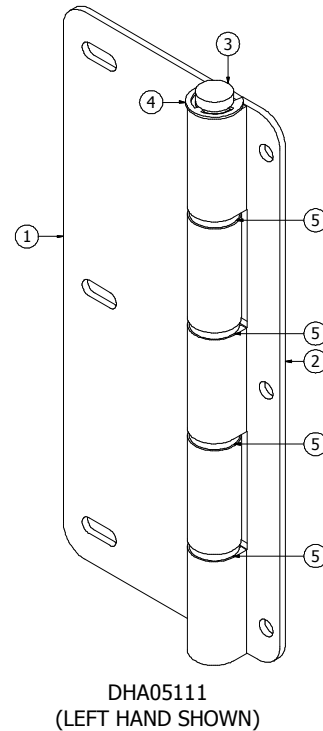

ITEM	PART NUMBER	DESCRIPTION	REV
1	ADS3380	ACCESS DOOR ASSEMBLY - 7H	01
2	DHA05111	OUTER DOOR HINGE ASSEMBLY	01
3	STR735	STRIKER PLATE SHORT WHITE	01
4	BH620	HEX HEAD BOLT - 6MM-1.00x20MM	01
5	BH820	HEX HEAD BOLT - 8MM 1.25x20MM	01
6	DH0215	DOOR HANDLE - WHITE	01
7	LTC235	DOOR ROLLER LATCH	01
8	WF618	FLAT WASHER - 6MMx18 OD	01
9	WF824	FLAT WASHER - 8MMx24 OD	01

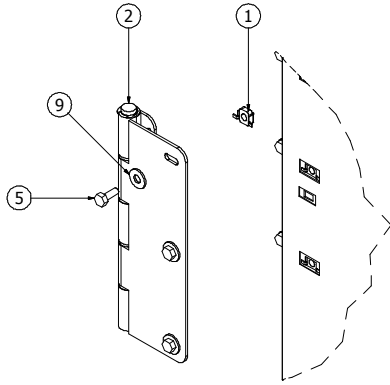

DETAIL A

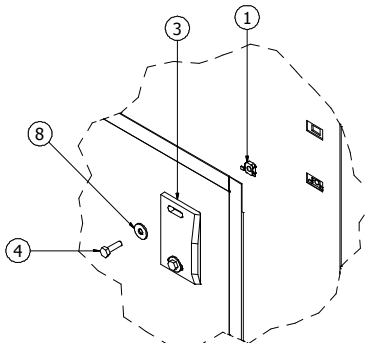

DETAIL B

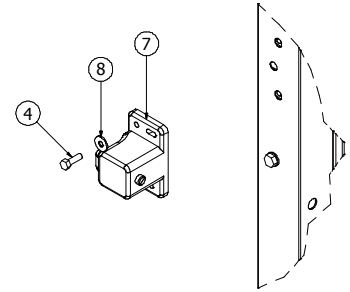

DETAIL C

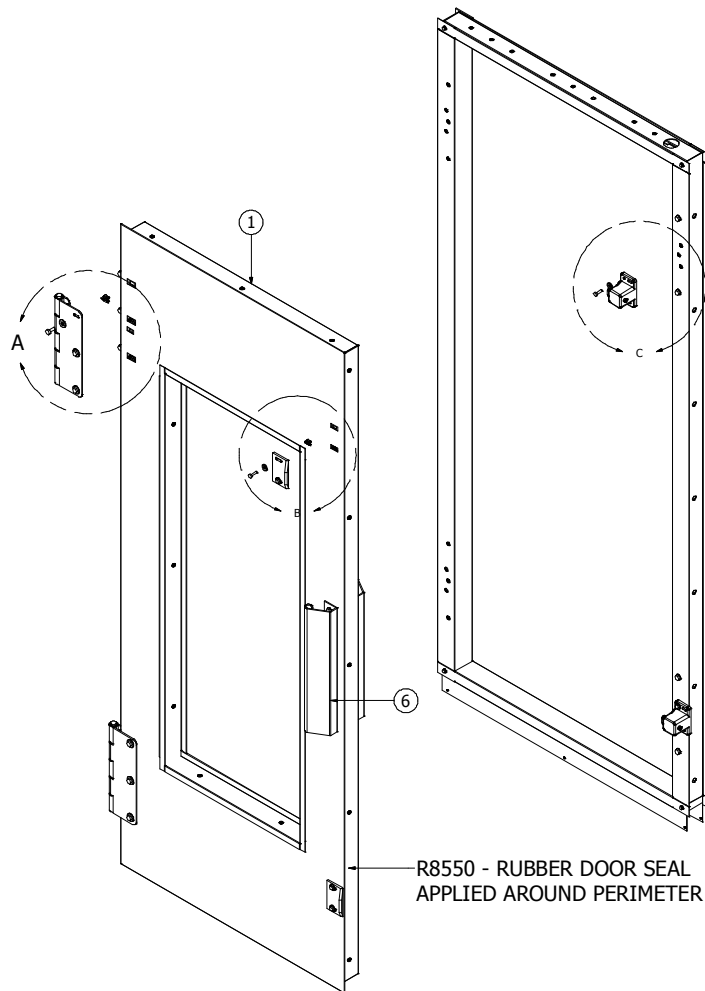

R8550 - RUBBER DOOR SEAL  
APPLIED AROUND PERIMETER OF DOOR SLAB

PERSONNEL DOOR

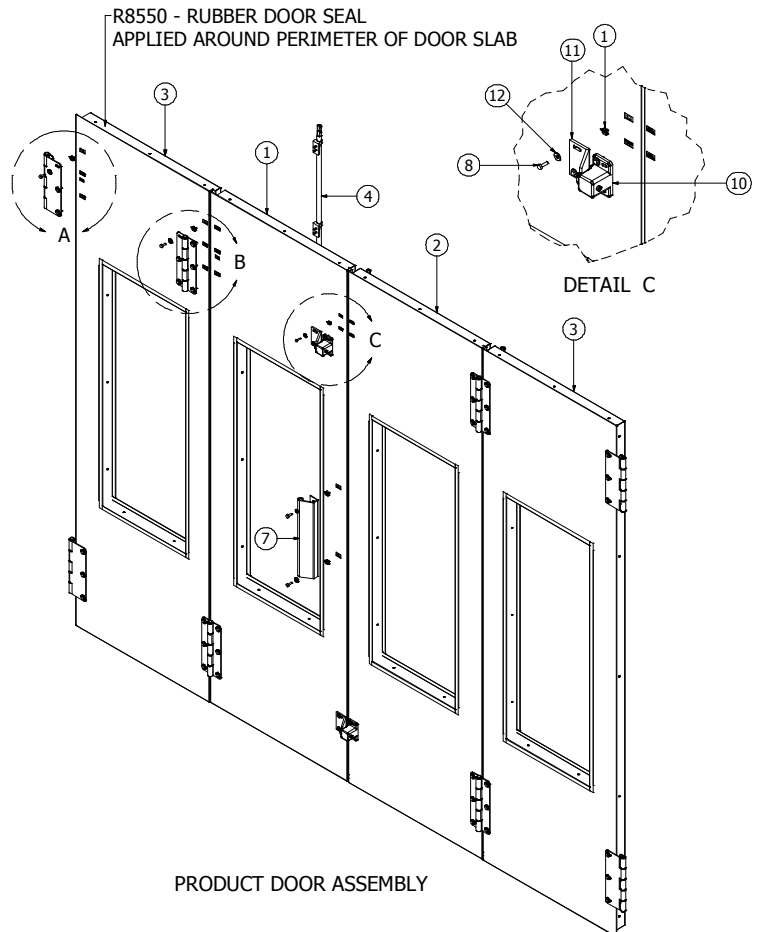
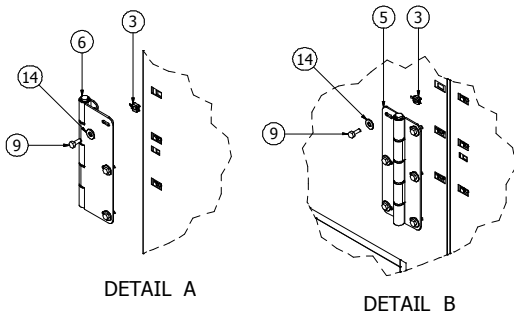
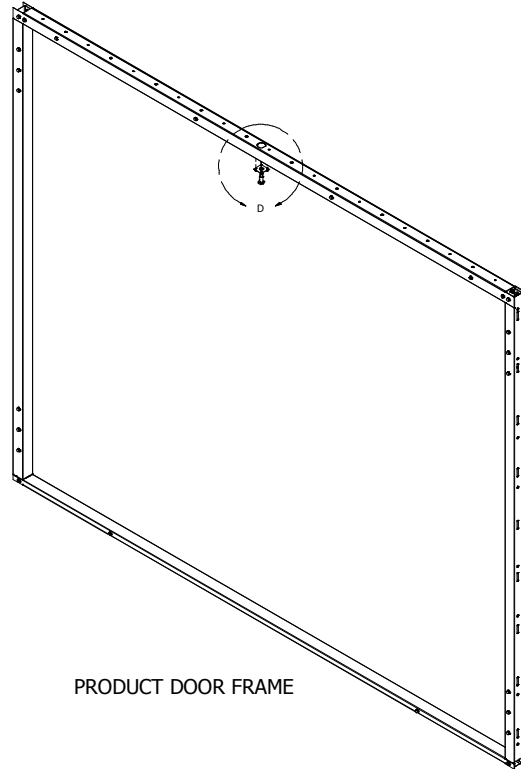
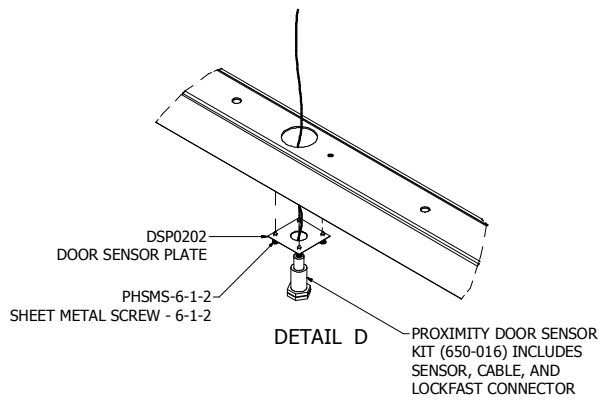

ITEM	PART NUMBER	DESCRIPTION	REV
1	SDS31104A	DOOR ASSEMBLY - ACCESS	01
2	SDS31104J	DOOR ASSEMBLY - ADJACENT	01
3	SDS31104O	DOOR ASSEMBLY - OUTBOARD	01
4	LRA01109	LOCKING ROD ASSEMBLY - 9H	01
5	DHA04110	INNER DOOR HINGE ASSEMBLY	01
6	DHA05111	OUTER DOOR HINGE ASSEMBLY	01
7	DH0215	DOOR HANDLE - WHITE	01
8	BH620	HEX HEAD BOLT - 6MM-1.00x20MM	01
9	BH820	HEX HEAD BOLT - 8MM 1.25x20MM	01
10	LTC235	DOOR ROLLER LATCH	01
11	STR1535	STRIKER PLATES	01
12	WF618	FLAT WASHER - 6MMx18 OD	01
13	WF816	FLAT WASHER - 8MMx16 OD	01
14	WF824	FLAT WASHER - 8MMx24 OD	01

ITEM	PART NUMBER	DESCRIPTION	REV
1	230-220	LAMPHOLDER T8 13MM SHUNTED	01
2	230-281	LAMPS FLUORESCENT 32W 2950 LUMENS T8	01
3	BS616	SOCKET HEAD BOLT, 6MMX16MM	01
4	GF-4	GLASS FRAME-S.SKIN (4-6TUBE)	01
5	NC6	CAGE NUT, 6MM	01
6	PRX8200	PROXIMITY SWITCH	01
7	WF618	FLAT WASHER, 6MMX18 OD	01

ITEM	PART NUMBER	DESCRIPTION	REV
1	10-24-NUT	FLNG LOCK REG ZINC NUT 3/16	01
2	230-220	LAMPHOLDER T8 13MM SHUNTED	01
3	230-281	LAMPS FLUORESCENT 32W 2950 LUMENS T8	01
4	BC1024	CARRIAGE BOLT, 10-24x1-2L	01
5	ESW10	STAR WASHER NUMBER 10	01
6	GF-6	GLASS FRAME-S.SKIN (4-6TUBE)	01
7	GT0443	3-8 RUBBER GROMMET	01
8	ICN-3P32-SC	BALLAST 120-277 32W T8 6 TUBE	01
9	REF2151	REFLECTOR, 6 TUBE	01

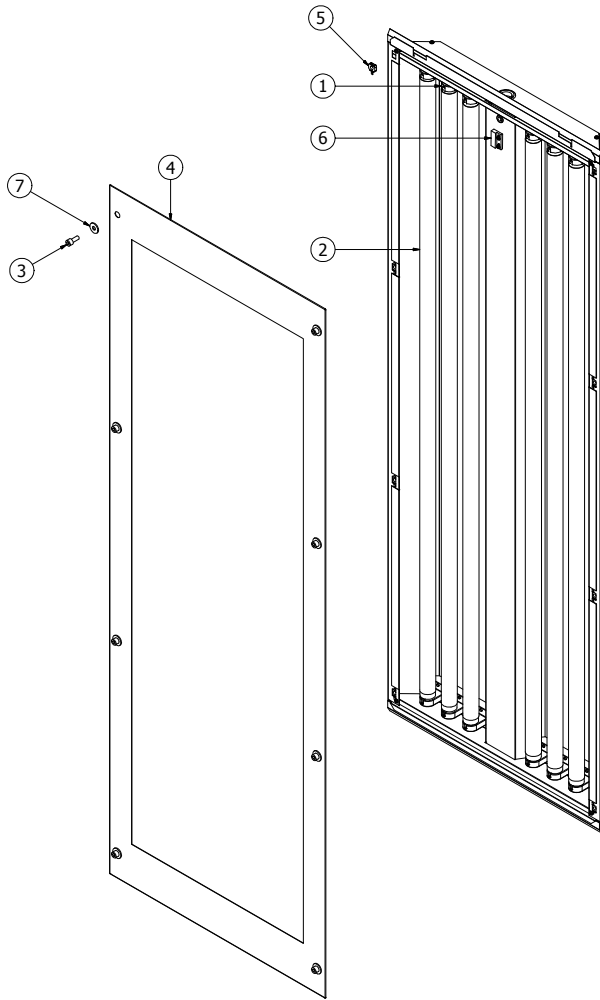

LIGHT FIXTURE, LAB12-6

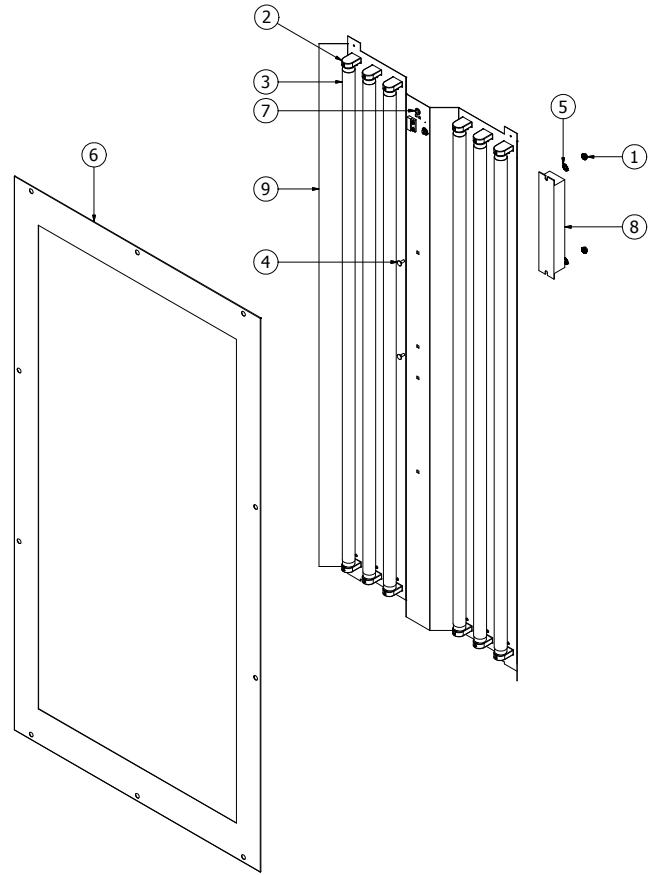

LIGHT FIXTURE, LAR12-6

GFS Spray Booths are Warranted as follows:

**A. Defects of Materials and Workmanship**

1. The Spray Booth is warranted against all defects in materials and/or workmanship for one (1) year from the date of installation.

2. The Spray Booth wall panels are warranted against rust-through for a period of five (5) years from the date of installation.

**B.** After completion of the installation, glass, light bulbs and filters are not subject to warranty. GFS, will provide all warranty parts. This Warranty does not cover filters and other parts subject to normal usage, wear and tear.

**C.** The site of any repairs and/or replacement is to be determined within the sole judgment of GFS. Repairs will be made by authorized service personnel.

*THERE IS NO OTHER EXPRESS WARRANTY, IMPLIED WARRANTIES, INCLUDING THOSE OF MERCHANTABILITY AND FITNESS FOR A PARTICULAR PURPOSE, ARE LIMITED TO ONE YEAR FROM PURCHASE AND TO THE EXTENT PERMITTED BY LAW ANY AND ALL IMPLIED WARRANTIES ARE EXCLUDED. THIS IS THE EXCLUSIVE REMEDY AND LIABILITY FOR CONSEQUENTIAL AND INCIDENTAL DAMAGES UNDER ANY AND ALL WARRANTIES ARE EXCLUDED TO THE EXTENT EXCLUSION IS PERMITTED BY LAW.*

This warranty does not cover:

**A.** Merchandise that has been damaged in transit or become inoperative because of;

a) wear occasioned by use, b) misuse, c) negligence, d) accident, e) incorrect maintenance, f) being repaired or altered outside of our facilities or other place designated by GFS, in any way which, in our judgment, affects its condition or operation.

**B.** Labor and incidental costs occasioned by removal, replacement or repair of merchandise other than by GFS.

**C.** Merchandise sold by GFS, which has been manufactured by and identified as the product of another company. This merchandise is subject to the warranties of such manufacturers up to one year.

**D.** Freight

**E.** Air make-up and burner units, unless proof of a GFS certified start-up (completed GFS Start-Up Form) is available.

GFS shall not be liable for loss, damage or delay due to, without limitation, acts of God, transportation delays, accident, fire, action of civil or military authority, adverse weather or any other causes beyond GFS' control. It is agreed that in no event shall GFS be responsible or liable for any consequential or incidental damages, including without limitation, loss of production or faulty production, loss of use or loss of profit.

Use the following guide to help you determine whether to contact the parts department or the customer service department with your questions. To contact either department, call **(800) 848-8738**. Then follow the voice prompts for the correct department. You may leave a message on the voice mail system, and someone will get back to you as soon as possible.

When contacting one of the GFS departments it is important to know the Model Number and Serial Number of your product. This information can be found on the ID Plate located on your product.

## Customer Service

GFS provides ongoing customer service for its customers. You can reach a customer service representative during regular business hours.

### Returning Parts

- All goods to be returned for credit or exchange must be accompanied by a Return Goods Authorization form. Call GFS to request form. Goods are subject to a 30% handling charge.
- Special non-stock items can be accepted only with the approval of our suppliers and are subject to any additional handling and restocking charges.

### Availability and Service

Critical operational parts for productions and customer safety will be shipped overnight when possible.

### Operation and Maintenance Manuals

GFS includes an electronic copy of the operation and maintenance manual with each job. You may purchase additional electronic or printed manuals by contacting customer service.

### Other Services

- Installation questions
- Arrange for an installation
- Arrange for a service call
- Notify GFS of undelivered parts or other shipment problems

Customer Service  
[info@gobalfinishing.com](mailto:info@gobalfinishing.com)

## Parts Department

All standard and custom products are designed and built by GFS. All parts are retained on file for immediate reference, replacement, and availability.

When you order replacement parts for your product, it is important to know the following information BEFORE ordering:

- Model Number
- Serial Number
- Part Number, Description & Quantity
- Purchase Order Number or Credit Card Number
- Preferred Shipping Method (UPS, Federal Express, Truck, Air, etc.)
- Complete Shipping & Billing Address.

### Pricing for Parts

Current prices and delivery costs will be quoted F.O.B. from Osseo, Wisconsin, Postal Code 54758.

### Supplier to Stock New/Replacement Parts

For replacement parts and supplies, contact the parts department. We will help you locate your nearest distributor.

Note: If you have questions about the warranty, please contact your distributor prior to contacting GFS.

Part Department :  
[parts@globalfinishing.com](mailto:parts@globalfinishing.com)