

**Homework Helpers**

**Grade 5  
Module 1**



## G5-M1-Lesson 1

Note: It is common to encourage students to simply “move the decimal point” a number of places when multiplying or dividing by powers of 10. Instead, encourage students to understand that the decimal point lives between the ones place and the tenths place. The decimal point does not move. Rather, the digits shift along the place value chart when multiplying and dividing by powers of ten.

Use the place value chart and arrows to show how the value of the each digit changes.

1.  $4.215 \times 10 = 42.15$

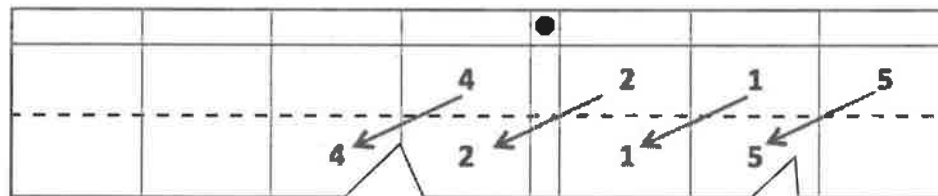

4 ones times 10 is 4 tens. Since I'm multiplying by 10, the value of each digit becomes 10 times greater.

When multiplying by 10, each digit shifts 1 place to the *left* on the place value chart.

2.  $421 \div 100 = 4.21$

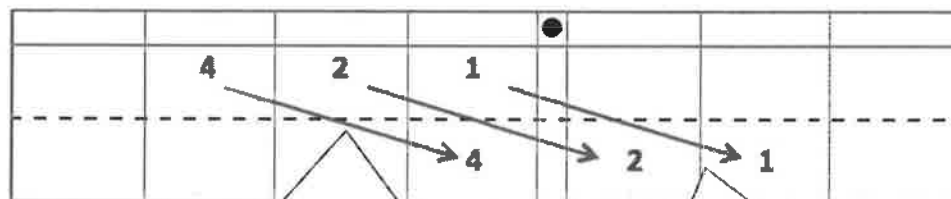

4 hundreds divided by 100 is 4 ones. Since I'm dividing by 100, the value of each digit becomes 100 times smaller.

When dividing by 100, each digit shifts 2 places to the *right* on the place value chart.

3. A student used his place value chart to show a number. After the teacher instructed him to multiply his number by 10, the chart showed 3,200.4. Draw a picture of what the place value chart looked like at first.

3 hundreds times 10 is 3 thousands. The original number must have had a 3 in the hundreds place.

thousands	hundreds	tens	ones	.	tenths	hundredths	thousandths
	3	2	0	.	0	4	

I used the place value chart to help me visualize what the original number was. When multiplying by 10, each digit must have shifted 1 place to the left, so I shifted each digit 1 place back to the right to show the original number.

4. A microscope has a setting that magnifies an object so that it appears 100 times as large when viewed through the eyepiece. If a small bug is 0.183 cm long, how long will the insect appear in centimeters through the microscope? Explain how you know.

		.			
		.	1	8	3
1 ←	8 ←		3 ←		

When multiplying by 100, each digit shifts 2 places to the left on the place value chart.

*The bug will appear to be 18.3 cm long through the microscope.*

*Since the microscope magnifies objects 100 times, the bug will appear to be 100 times larger. I used a place value chart to show what happens to the value of each digit when it is multiplied by 100. Each digit shifts 2 places to the left.*

## G5-M1-Lesson 2

1. Solve.

a.  $4,258 \times 10 = \underline{42,580}$

I visualized a place value chart. 8 ones times 10 is 8 tens. When multiplying by 10, each digit shifts 1 place to the *left*.

c.  $3.9 \times 100 = \underline{390}$

The factor 100, has 2 zeros, so I can visualize each digit shifting 2 places to the *left*.

b.  $4,258 \div 10 = \underline{425.8}$

When dividing by 10, each digit shifts 1 place to the *right*.

d.  $3.9 \div 100 = \underline{0.039}$

The divisor, 100, has 2 zeros, so each digit shifts 2 places to the *right*.

$$7 \times 1 \text{ hundred} = 7 \text{ hundreds} = 700$$

2. Solve.

a.  $9,647 \times 100 = \underline{964,700}$

$$7 \div 1 \text{ thousand} = 7 \text{ thousandths} = 0.007$$

b.  $9,647 \div 1,000 = \underline{9.647}$

c. Explain how you decided on the number of zeros in the product for part (a).

*I visualized a place value chart. Multiplying by 100 shifts each digit in the factor 9,647 two places to the left, so there were 2 additional zeros in the product.*

d. Explain how you decided where to place the decimal in the quotient for part (b).

*The divisor, 1,000, has 3 zeros, so each digit in 9,647 shifts 3 places to the right. When the digit 9 shifts 3 places to the right, it moves to the ones places, so I knew the decimal point needed to go between the ones place and the tenths place. I put the decimal between the 9 and the 6.*

3. Jasmine says that 7 hundredths multiplied by 1,000 equals 7 thousands. Is she correct? Use a place value chart to explain your answer.

*Jasmine is not correct. 7 ones  $\times$  1,000 would be 7 thousands.*

*But  $0.07 \times 1,000 = 70$ . Look at my place value chart.*

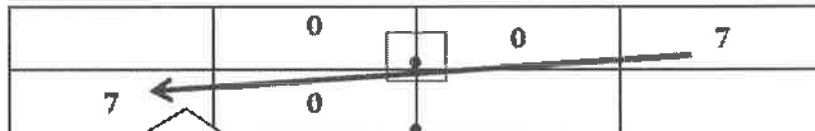

The factor 1,000 has 3 zeros, so the digit 7 shifts 3 places to the left on the place value chart.

4. Nino's class earned \$750 selling candy bars for a fundraiser.  $\frac{1}{10}$  of all the money collected was from sales made by Nino. How much money did Nino raise?

The whole tape represents all of the money earned by Nino's class.

Nino collected  $\frac{1}{10}$  of all the money, so I partition the tape diagram into 10 equal

\$750

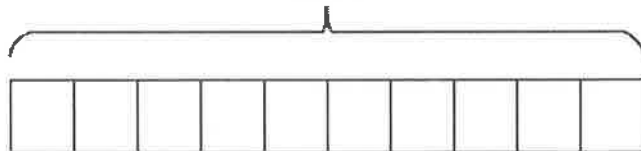

Nino's sales

The value of this 1 unit will tell me how much money Nino earned for his class.

10 units = \$750

1 unit =  $\$750 \div 10$

1 unit = \$75

Nino raised \$75.

## G5-M1-Lesson 3

1. Write the following in exponential form.

a.  $10 \times 10 \times 10 = \underline{10^3}$

10 is a factor 3 times, so the exponent is 3. I can read this as, "ten to the third power."

c.  $100,000 = \underline{10^5}$

b.  $1,000 \times 10 = \underline{10^4}$

1,000 =  $10 \times 10 \times 10$ , so this expression uses 10 as a factor 4 times. The exponent is 4.

d.  $100 = \underline{10^2}$

I recognize a pattern. 100 has 2 zeros. Therefore, the exponent is 2. One hundred equals 10 to the 2<sup>nd</sup> power.

2. Write the following in standard form.

a.  $6 \times 10^3 = \underline{6,000}$

$10^3$  is equal to 1,000. 6 times 1 thousand is 6 thousand.

c.  $643 \div 10^3 = \underline{0.643}$

b.  $60.43 \times 10^4 = \underline{604,300}$

The exponent 4 tells me how many places each digit will shift to the left.

d.  $6.4 \div 10^2 = \underline{0.064}$

The exponent 2 tells me how many places each digit will shift to the right.

3. Complete the patterns.

a. 0.06      0.6      6      60      600      6,000

6 tenths is larger than 6 hundredths. Each number in the pattern is 10 times larger than the previous number.

b. 92,100      9,210      921      92.1      9.21      0.921

The numbers are getting smaller in this pattern.

The digits have each shifted 1 place to the right. The pattern in this sequence is "divide by  $10^1$ ."

## G5-M1-Lesson 4

1. Convert and write an equation with an exponent.

1 meter is equal to 100 centimeters.

a. 4 meters to centimeters  $\underline{4} \text{ m} = \underline{400} \text{ cm}$

$\underline{4 \times 10^2 = 400}$

1 meter is equal to 1,000 millimeters.

b. 2.8 meters to millimeters  $\underline{2.8} \text{ m} = \underline{2,800} \text{ mm}$

$\underline{2.8 \times 10^3 = 2,800}$

In the first 2 problems, I am converting a *larger* unit to a *smaller* unit. Therefore, I need to multiply to find the equivalent length.

2. Convert using an equation with an exponent.

There are 100 centimeters in 1 meter.

a. 87 centimeters to meters  $\underline{87} \text{ cm} = \underline{0.87} \text{ m}$

$\underline{87 \div 10^2 = 0.87}$

There are 1,000 millimeters in 1 meter.

b. 9 millimeters to meters  $\underline{9} \text{ mm} = \underline{0.009} \text{ m}$

$\underline{9 \div 10^3 = 0.009}$

In these 2 problems, I am converting a *smaller* unit to a *larger* unit. Therefore, I need to divide to find the equivalent length.

3. The height of a cellphone is 13 cm. Express this measurement in meters. Explain your thinking. Include an equation with an exponent in your explanation.

$13 \text{ cm} = 0.13 \text{ m}$

In order to rename smaller units as larger units, I'll need to divide.

Since 1 meter is equal to 100 centimeters, I divided the number of centimeters by 100.

$13 \div 10^2 = 0.13$

I need to include an equation with an exponent, so I'll express 100 as  $10^2$ .



## G5-M1-Lesson 5

1. Express as decimal numerals.

- a. Eight and three hundred fifty-two thousandths

8.352

- b.  $\frac{6}{100}$

0.06

- c.  $5\frac{132}{1000}$

5.132

The word *and* separates the whole numbers from the decimal numbers.

I can rewrite this fraction as a decimal. There are zero ones and zero tenths in the fraction *6 hundredths*.

2. Express in words.

- a. 0.034

*Thirty-four thousandths*

- b. 73.29

*Seventy-three and twenty-nine hundredths*

The word *and* separates the whole numbers from the decimal numbers.

3. Write the number in expanded form using decimals and fractions.

303.084

$$3 \times 100 + 3 \times 1 + 8 \times 0.01 + 4 \times 0.001$$

$$3 \times 100 + 3 \times 1 + 8 \times \frac{1}{100} + 4 \times \frac{1}{1000}$$

This expanded form uses decimals. 8 hundredths is the same as 8 units of 1 hundredth or ( $8 \times 0.01$ ).

This expanded form uses fractions.

$$\frac{1}{1000} = 0.001. \text{ Both are read as}$$

4. Write a decimal for each of the following.

a.  $4 \times 100 + 5 \times 1 + 2 \times \frac{1}{10} + 8 \times \frac{1}{1000}$

405.208

b.  $9 \times 1 + 9 \times 0.1 + 3 \times 0.01 + 6 \times 0.001$

9.936

There are 0 tens and 0 hundredths in expanded form, so I wrote 0 tens and 0 hundredths in standard form too.

$3 \times 0.01$  is 3 units of 1 hundredth, which I can write as a 3 in the hundredths place.

## G5-M1-Lesson 6

1. Show the numbers on the place value chart using digits. Use  $>$ ,  $<$ , or  $=$  to compare.

$$43.554 > 43.545$$

	4	3	.	5	5	4
	4	3	.	5	4	5

5 hundredths is greater than 4 hundredths. Therefore,  
 $43.554 > 43.545$ .

I put each digit of both numbers in the place value chart. Now I can easily compare the values.

2. Use the  $>$ ,  $<$ , or  $=$  to compare the following.

a.  $7.4 = 74$  tenths

10 tenths = 1 one      20 tenths = 2 ones      70 tenths = 7 ones  
 Therefore, 74 tenths = 7 ones and 4 tenths.

b.  $2.7 >$  Twenty-seven hundredths

1 one = 10 tenths      2 ones = 20 tenths       $2.7 = 27$  tenths  
 Tenths are a larger unit than hundredths, therefore 27 tenths is *greater* than 27 hundredths.

c.  $3.12 <$  312 tenths

I can think of both numbers in unit form: 312 hundredths  $<$  312 tenths. Hundredths are a smaller unit than tenths.  
 I can also think of both numbers in decimal notation:  $3.12 <$  31.2.

d.  $1.17 >$  1.165

Both of these numbers have 1 one and 1 tenth. But 7 hundredths is *greater* than 6 hundredths. I know that 1.17 is *greater* than 1.165.

I need to be careful! Although 1.165 has more digits than 1.17, it doesn't always mean it has a greater value.

I also know that  $1.17 = 1.170$ . When both numbers have the same number of digits, I can clearly see that  $1.170 >$  1.165.

3. Arrange the numbers in *increasing* order.

8.719   8.79   8.7   8.179

8.179, 8.7, 8.719, 8.79

Increasing order means I need to list the numbers from *least* to *greatest*.

8	7	1	9
8	7	9	
8	7		
8	1	7	9

To make comparing easier, I'm going to use a place value chart.

The 9 hundredths is greater than all of the other digits in the hundredths place. 8.79 is the largest number.

All of the numbers have 8 ones. 1 tenth is less than 7 tenths, so 8.179 is the smallest number.

Decreasing order means I need to list the numbers from *greatest* to *least*.

4. Arrange the numbers in *decreasing* order.

56.128   56.12   56.19   56.182

56.19, 56.182, 56.128, 56.12

This time I'll just visualize the place value chart in my head.

I'll begin by comparing the largest units, tens, first. All of the numbers have 5 tens, 6 ones, and 1 tenth. I'll look to the hundredths place next to compare.

Even though this number has only 4 digits, it's actually the largest number. The 9 in the hundredths place is the largest of all the digits in the hundredths places.

When I compare 56.12 and 56.128 to the other numbers, I see that they both have the fewest number of hundredths. However, I know that 56.128 is larger because it has 8 thousandths more than 56.12.

### G5-M1-Lesson 7

Round to the given place value. Label the number lines to show your work. Circle the rounded number. Use a place value chart to show your decompositions for each.

1. 3.27

**a. ones**

The number halfway between 3 ones and 4 ones is 3.5.

3.27 is less than the halfway mark and is closer to 3 ones. 3.27 rounds down to 3 when rounded to the nearest one.

I know that 3.27 lies somewhere between 3 ones and 4 ones on the number line. When rounding to the nearest one, I need to identify if it's closer to 3 ones or 4 ones.

**b. tenths**

3.27 is more than the halfway mark and is closer to 33 tenths. 3.27 rounds up to 3.3 when rounded to the nearest tenth.

The number halfway between 32 tenths and 33 tenths is 3.25.

In order to round 3.27 to the nearest tenth, I need to know how many tenths are in 3.27. The chart below tells me that there are 32 tenths in 3.27.

ones	tenths	hundredths
3	2	7
	32	7
		327

I can think of 3.27 in several ways. I can say it is 3 ones + 2 tenths + 7 hundredths. I can also think of it as 32 tenths + 7 hundredths or 327 hundredths.

2. Rosie’s pedometer said she walked 1.46 miles. She rounded her distance to 1 mile, and her brother, Isaac, rounded her distance to 1.5 miles. They are both right. Why?

*Rosie rounded the distance to the nearest mile, and Isaac rounded the distance to the nearest tenth of a mile.*

1.46 rounded to the nearest one is 1.

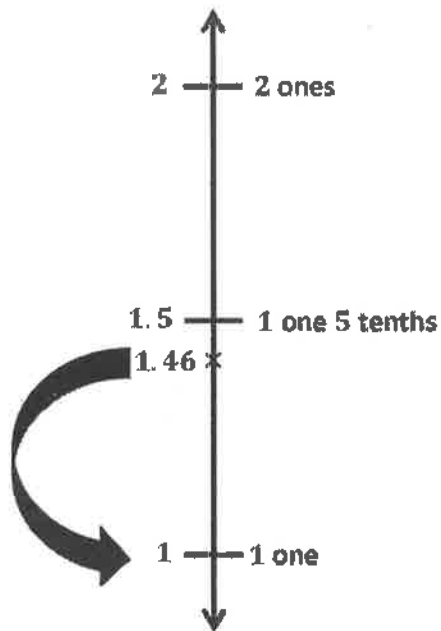

1.46 rounded to the nearest tenth is 15 tenths or 1.5.

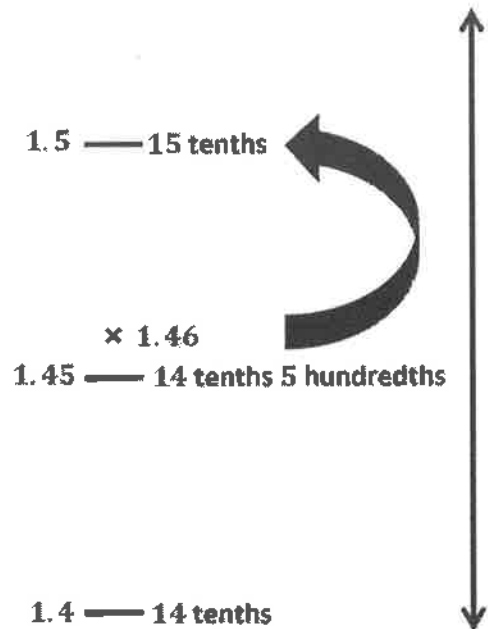

## G5-M1-Lesson 8

1. Round the quantity to the given place value. Draw number lines to explain your thinking. Circle the rounded value on the number line.

Round 23.245 to the nearest tenth and hundredth.

2 tens = 200 tenths  
3 ones = 30 tenths  
There are 232 tenths  
4 hundredths 5 thousandths in  
the number 23.245.

2 tens = 2,000 hundredths  
3 ones = 300 hundredths  
2 tenths = 20 hundredths  
There are 2,324 hundredths  
5 thousandths in the number 23.245.

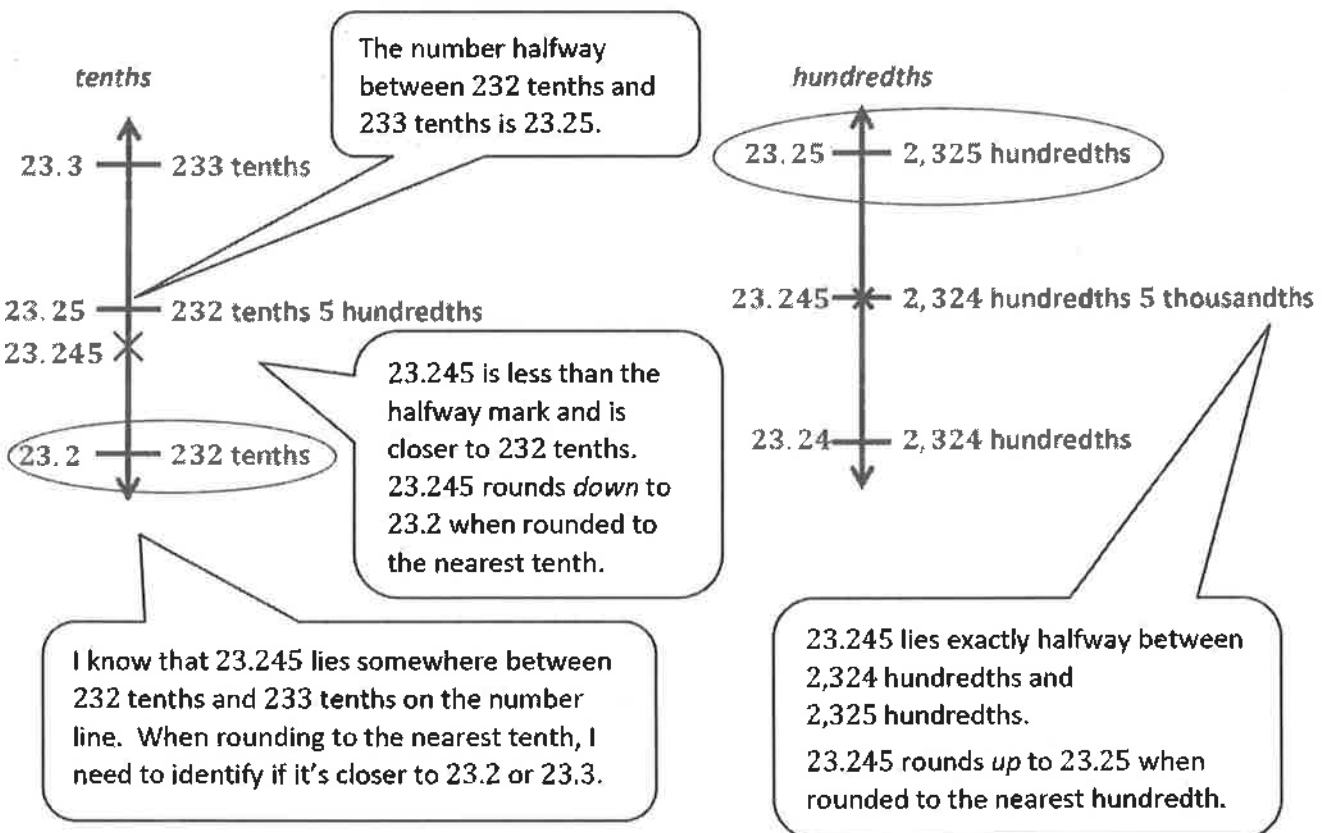

2. A decimal number has two digits to the right of its decimal point. If we round it to the nearest tenth, the result is 28.7. What is the maximum possible value of this decimal? Use words and the number line to explain your reasoning.

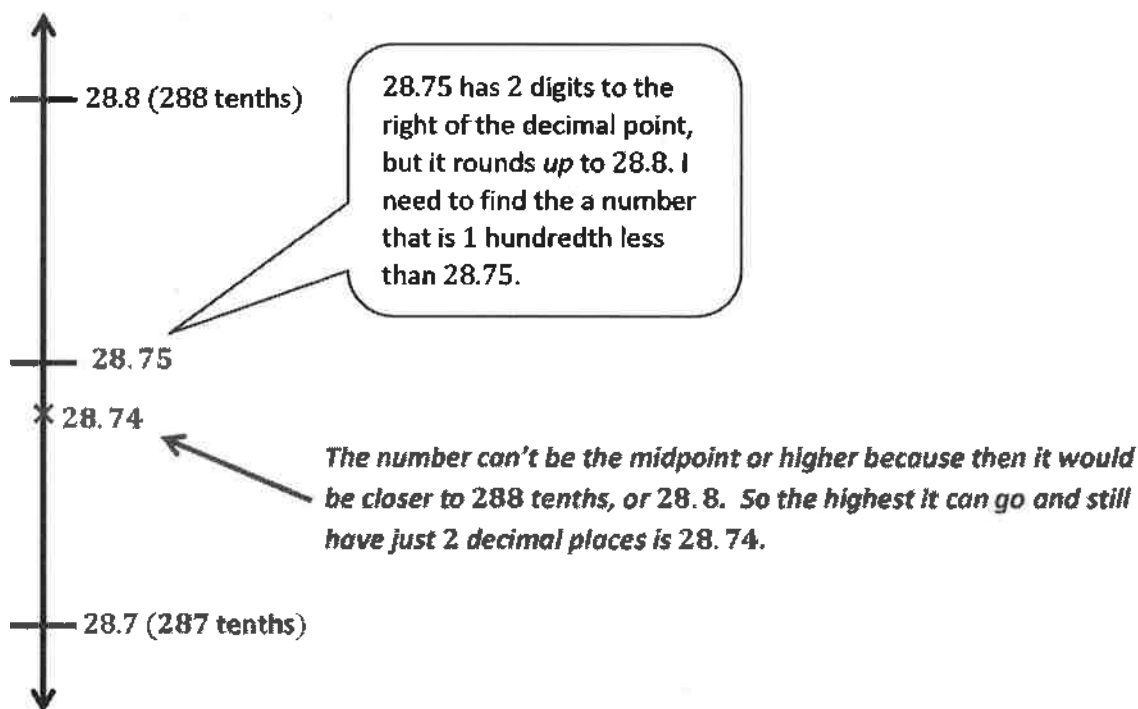



## G5-M1-Lesson 9

Note: Adding decimals is just like adding whole numbers—combine like units. Study the examples below:

$$2 \text{ apples} + 3 \text{ apples} = 5 \text{ apples}$$

$$2 \text{ ones} + 3 \text{ ones} = 5 \text{ ones}$$

$$2 \text{ tens} + 3 \text{ tens} = 5 \text{ tens} = 50$$

$$2 \text{ hundredths} + 3 \text{ hundredths} = 5 \text{ hundredths} = 0.05$$

1. Solve.

a.  $2 \text{ tenths} + 3 \text{ tenths} = \underline{5}$  tenths

I'll combine the like units, tenths, to get 5 tenths.

The standard form is  $0.2 + 0.3 = 0.5$ .

b.  $26 \text{ hundredths} + 5 \text{ hundredths} = \underline{31}$  hundredths =  $\underline{3}$  tenths  $\underline{1}$  hundredths

I'll combine the like units, hundredths, and get 31 hundredths.

The standard form is  $0.26 + 0.05 = 0.31$ .

10 hundredths = 1 tenth  
20 hundredths = 2 tenths  
30 hundredths = 3 tenths

c.  $5 \text{ ones } 2 \text{ tenths} + 4 \text{ tenths} = \underline{56}$  tenths

I'll combine the like units and get 5 ones 6 tenths, which is the same as 56 tenths.

1 one = 10 tenths  
5 ones = 50 tenths

The standard form is  $5.2 + 0.4 = 5.6$ .

2. Solve using the standard algorithm.

a.  $0.3 + 0.91 = \underline{1.21}$

3 tenths + 9 tenths is 12 tenths. I'll record 12 tenths as 1 one and 2 tenths.

When setting up the algorithm, I need to be sure to add like units. Therefore I'll line up the tens with the tens, the ones with the ones et cetera.

b.  $75.604 + 12.087 = \underline{87.691}$

$$\begin{array}{r} 75.604 \\ + 12.087 \\ \hline 87.691 \end{array}$$

4 thousandths + 7 thousandths is 11 thousandths. I'll record 11 thousandths as 1 hundredth 1 thousandth.

3. Anthony spends \$6.49 on a book. He also buys a pencil for \$2.87 and an eraser for \$1.15. How much money does he spend altogether?

$\$6.49 + \$2.87 + \$1.15 = \$10.51$

I'll add all three items together to find the total price.

$$\begin{array}{r} 6.49 \\ 2.87 \\ +1.15 \\ \hline 10.51 \end{array}$$

9 hundredths + 7 hundredths + 5 hundredths is 21 hundredths. I'll record 21 hundredths as 2 tenths 1 hundredth.

4 tenths + 8 tenths + 1 tenth + 2 tenths is 15 tenths. I'll record 15 tenths as 1 one and 5 tenths.

Anthony spends \$10.51.

## G5-M1-Lesson 10

Note: Subtracting decimals is just like subtracting whole numbers—subtract like units. Study the examples below.

- 5 apples  $-$  1 apple = 4 apples  
 5 ones  $-$  1 one = 4 ones  
 5 tens  $-$  1 ten = 4 tens  
 5 hundredths  $-$  1 hundredth = 4 hundredths

1. Subtract.

a. 7 tenths  $-$  4 tenths = 3 tenths

I'll subtract the like units, tenths, to get 3 tenths.

The standard form is  $0.7 - 0.4 = 0.3$ .

I'll look at the units carefully.  
 A *hundred* is different than a *hundredth*.

I'll subtract 3 hundredths from 8 hundredths,  
 and get 5 hundredths.

b. 4 hundreds 8 hundredths  $-$  3 hundredths = 4 hundreds 5 hundredths

The standard form is  $400.08 - 0.03 = 400.05$ .

1.7 is the same as 1.70.

2. Solve  $1.7 - 0.09$  using the standard algorithm.

When setting up the algorithm, I need to be sure to subtract like units. Therefore, I'll line up the ones with the ones, the tenths with the tenths, etc.

$$\begin{array}{r} 1. \cancel{7} \cancel{0} \\ - 0.09 \\ \hline 1.61 \end{array}$$

There are 0 hundredths, so I can't subtract 9 hundredths. I'll rename 7 tenths as 6 tenths 10 hundredths.

10 hundredths minus 9 hundredths is equal to 1 hundredth.

6 ones 3 tenths = 6.3 = 6.30  
58 hundredths = 0.58

There are 0 hundredths, so I can't subtract 8 hundredths. I'll rename 3 tenths as 2 tenths 10 hundredths.

3. Solve 6 ones 3 tenths - 58 hundredths.

I'll rename 6 ones as 5 ones 10 tenths. 10 tenths, plus the 2 tenths already there, makes 12 tenths.

$$\begin{array}{r} 5 \quad 12 \quad 10 \\ \cancel{\$} \quad \cancel{\cancel{\$}} \quad \cancel{\cancel{\$}} \\ - 0. \quad 5 \quad 8 \\ \hline 5. \quad 7 \quad 2 \end{array}$$

10 hundredths minus 8 hundredths is equal to 2 hundredths.

Students can solve using a variety of methods. This problem may not require the standard algorithm as some students can compute mentally.

4. A pen costs \$2.57. It costs \$0.49 more than a ruler. Kayla bought two pens and one ruler. She paid with a ten-dollar bill. How much change does Kayla get? Use a tape diagram to show your thinking.

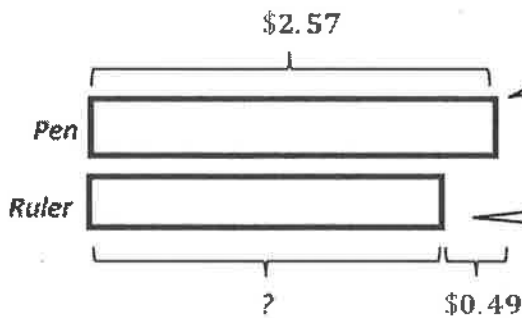

I'll draw a tape diagram to represent the pen and label it \$2.57.

Since the pen costs more than the ruler, I'll draw a shorter tape for the ruler.

The difference between the pen and the ruler is \$0.49.

I'll find the price of the ruler. It's \$2.08.

$$\begin{array}{r} 4 \quad 17 \\ \$2. \quad \cancel{\cancel{\$}} \\ - \$0. \quad 4 \quad 9 \\ \hline \$2. \quad 0 \quad 8 \end{array}$$

$$\$2.57 + \$2.57 + \$2.08 = \$7.22$$

$$\begin{array}{r} 0 \quad 9 \quad 9 \quad 10 \\ \$\cancel{1} \quad \cancel{\cancel{\$}} \quad \cancel{\cancel{\$}} \quad \cancel{\cancel{\$}} \\ - \$7. \quad 2 \quad 2 \\ \hline \$2. \quad 7 \quad 8 \end{array}$$

I'll add the price of two pens and one ruler together. It's \$7.22.

$$\begin{array}{r} \$2. \quad 5 \quad 7 \\ \$2. \quad 5 \quad 7 \\ + \$2. \quad 0 \quad 8 \\ \hline \cancel{1} \quad \cancel{2} \\ \$7. \quad 2 \quad 2 \end{array}$$

Kayla's change is \$2.78.

I'll subtract the total cost from \$10. Kayla's change will be \$2.78.

Note: Encourage your child to use a variety of strategies when solving. The standard algorithm may not always be necessary for some students. Ask them about different ways to solve the problem. Below you'll find some alternate solution strategies that could be applied.

$$\$2.57 + \$2.57 + \$2.08 = \$7.22$$

When finding the total cost of the 3 items, I can think of adding  $\$2.50 + \$2.50 + \$2$ , which is equal to  $\$7$ . Then I'll add the remaining  $7\text{¢} + 7\text{¢} + 8\text{¢}$ , which is  $22\text{¢}$ . The total then, is  $\$7 + \$0.22 = \$7.22$ . I can do all of this mentally!

Then when finding the amount of change Kayla gets, I can use another strategy to solve.

Instead of finding the difference of  $\$10$  and  $\$7.22$  using the subtraction algorithm, I can count up from  $\$7.22$ .

$$\$7.22 \xrightarrow{+ 3\text{¢}} \$7.25 \xrightarrow{+ 75\text{¢}} \$8.00 \xrightarrow{+ \$2} \$10.00$$

3¢ more makes  $\$7.25$ .

3 quarters, or 75 cents, more makes  $\$8$ .

$\$2$  more makes  $\$10$ .

2 dollars, 3 quarters, and 3 pennies is  $\$2.78$ . That's what Kayla gets back.

*Kayla gets  $\$2.78$  back in change.*

## G5-M1-Lesson 11

1. Solve by drawing disks on a place value chart. Write an equation, and express the product in standard form.

- a. 2 copies of 4 tenths

$$= 2 \times 0.4$$

$$= 0.8$$

2 copies means 2 groups. So, I'll multiply 2 times 4 tenths. The answer is 8 tenths, or 0.8.

I'll draw a place value chart to help me solve, and this dot is the decimal point.

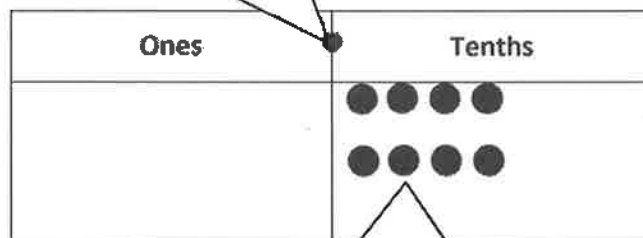

Each dot represents 1 tenth, so I'll draw 2 groups of 4 tenths.

- b. 3 times as much as 6 hundredths

$$= 3 \times 0.06$$

$$= 0.18$$

I'll multiply 3 times 6 hundredths. The answer is 18 hundredths, or 0.18.

I'll draw 3 groups of 6 hundredths.

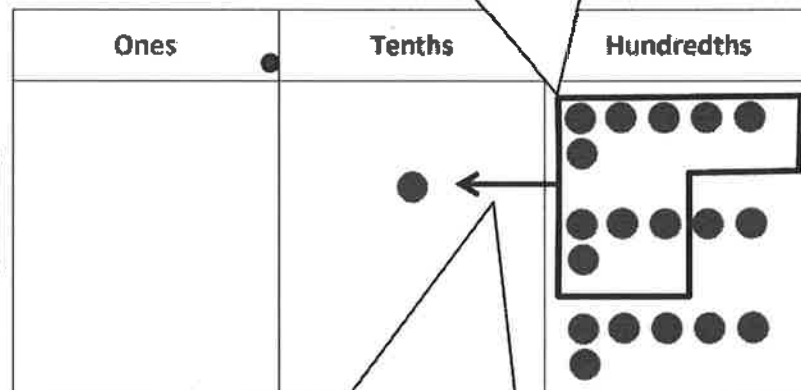

I'll bundle 10 hundredths and exchange them for 1 tenth.

2. Draw an area model, and find the sum of the partial products to evaluate each expression.

a.  $2 \times 3.17$

3.17 is the same as 3 ones 1 tenth 7 hundredths.

The factor 2 represents the width of the area model.

The factor 3.17 represents the length of the area model.

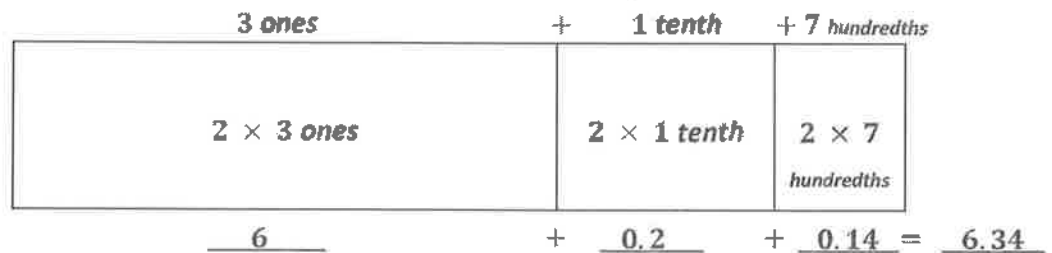

I'll multiply 2 times each place value unit.

$2 \times 3 \text{ ones} = 6 \text{ ones} = 6$

$2 \times 1 \text{ tenth} = 2 \text{ tenths} = 0.2$

$2 \times 7 \text{ hundredths} = 14 \text{ hundredths} = 0.14$

The product of 2 and 3.17 is 6.34.

b. 4 times as much as 30.162

There are 0 ones in 30.162, so my area model does not include the ones.

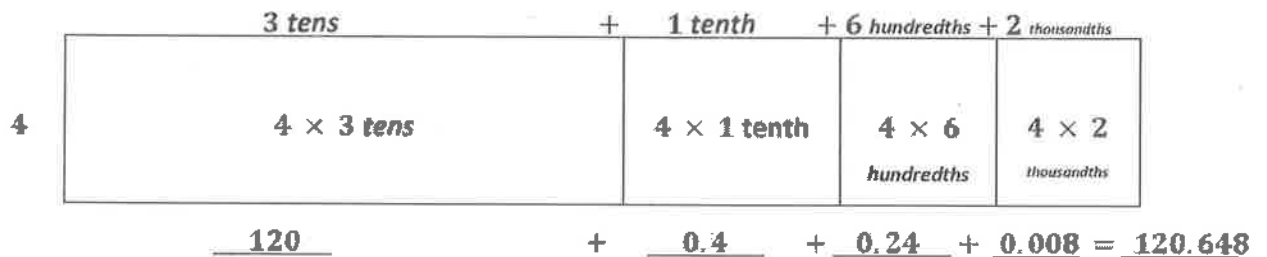

I'll multiply 4 times each place value unit.

$4 \times 3 \text{ tens} = 12 \text{ tens} = 120$

$4 \times 1 \text{ tenth} = 4 \text{ tenths} = 0.4$

$4 \times 6 \text{ hundredths} = 24 \text{ hundredths} = 0.24$

$4 \times 2 \text{ thousandths} = 8 \text{ thousandths} = 0.008$

The product of 4 and 30.162 is 120.648.

### G5-M1-Lesson 12

1. Choose the reasonable product for each expression. Explain your thinking in the spaces below using words, pictures, or numbers.

a.  $3.1 \times 3$

930

93

9.3

0.93

3.1 is just a little more than 3. A reasonable product would be just a little more than 9.

$3 \times 3 = 9$ . I looked for a product that was close to 9.

b.  $8 \times 7.036$

5.6288

56.288

562.88

5,628.8

This product is not reasonable. How could  $8 \times 7.036$  be less than both factors?

These 2 products are much too large.

$8 \times 7 = 56$ . I looked for a product that was close to 56.

2. Lenox weighs 9.2 kg. Her older brother is 3 times as heavy as Lenox. How much does her older brother weigh in kilograms?

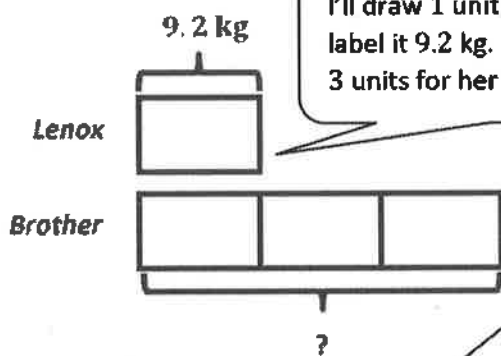

I'll draw 1 unit for Lenox and label it 9.2 kg. Then I'll draw 3 units for her brother.

I can visualize an area model to solve  $3 \times 9.2$ .

$$3 \times 9 \text{ ones} = 27 \text{ ones} = 27$$

$$3 \times 2 \text{ tenths} = 6 \text{ tenths} = 0.6$$

$$27 + 0.6 = 27.6$$

$$1 \text{ unit} = 9.2 \text{ kg}$$

$$3 \text{ units} = 3 \times 9.2 \text{ kg}$$

$$= 27.6 \text{ kg}$$

Lenox's older brother weighs 27.6 kilograms.

To find her brother's weight, I'll multiply Lenox's weight by 3. The answer is 27.6 kilograms.



## G5-M1-Lesson 13

Note: The use of unit language (e.g., 21 hundredths rather than 0.21) allows students to use knowledge of basic facts to compute easily with decimals.

1. Complete the sentence with the correct number of units, and then complete the equation.

$$0.21 = 21 \text{ hundredths}$$

3 groups of 7 hundredths is 0.21.

$$0.21 \div 3 = \underline{0.07}$$

I know the basic fact  $3 \times 7 = 21$ . This is similar.  
 $3 \times 7$  hundredths = 21 hundredths

Since  $21 \div 3 = 7$ , then  
 $21$  hundredths  $\div 3 = 7$  hundredths

2. Complete the number sentence. Express the quotient in units and then in standard form.

Since the divisor is 4, I'll decompose 8.16 into 8 ones and 16 hundredths.  
 Both 8 and 16 are multiples of 4.

a.  $8.16 \div 4 = \underline{8}$  ones  $\div 4 + \underline{16}$  hundredths  $\div 4$

$$= \underline{2} \text{ ones} + \underline{4} \text{ hundredths}$$

$$8 \text{ ones} \div 4 = 2 \text{ ones} = 2$$

$$= \underline{2.04}$$

$$16 \text{ hundredths} \div 4 = 4 \text{ hundredths} = 0.04$$

$$2 + 0.04 = 2.04$$

Since the divisor is 6, I'll decompose 1.242 into 12 tenths and 42 thousandths.  
 Both 12 and 42 are multiples of 6.

b.  $1.242 \div 6 = \underline{(12 \text{ tenths} \div 6) + (42 \text{ thousandths} \div 6)}$

$$= \underline{2 \text{ tenths} + 7 \text{ thousandths}}$$

$$12 \text{ tenths} \div 6 = 2 \text{ tenths} = 0.2$$

$$= \underline{0.207}$$

$$42 \text{ thousandths} \div 6 = 7 \text{ thousandths} = 0.007$$

3. Find the quotients. Then, use words, numbers, or pictures to describe any relationships you notice between the pair of problems and their quotients.

a.  $35 \div 5 = \underline{\quad 7 \quad}$

I know this basic fact!

b.  $3.5 \div 5 = \underline{\quad 0.7 \quad}$

I can use that basic fact to help me solve this one.  
 $35 \text{ tenths} \div 5 = 7 \text{ tenths} = 0.7$

*Both problems are dividing by 5, but the quotient for part (a) is 10 times larger than the quotient for (b). That makes sense because the number we started with in part (a) is also 10 times larger than the number we started with in part (b).*

4. Is the quotient below reasonable? Explain your answer.

a.  $0.56 \div 7 = 8$

$56 \text{ hundredths} \div 7 = 8 \text{ hundredths}$

$0.56 = 56 \text{ hundredths}$

*No, the quotient is not reasonable.*

$56 \div 7 = 8$ , so  $56 \text{ hundredths} \div 7$  must be  $8 \text{ hundredths}$ .

5. A toy airplane weighs 3.69 kg. It weighs 3 times as much as a toy car. What is the weight of the toy car?

I draw 1 tape diagram to show the weight of the airplane.

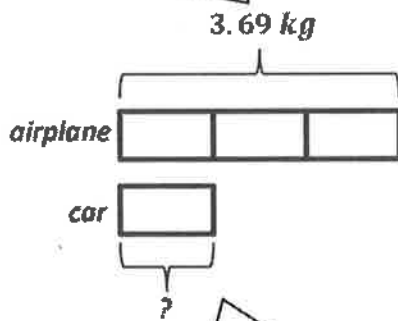

The airplane weighs 3 times as much as the car, so I partition the tape diagram, into 3 equal units.

The car is equal to the weight of 1 unit.

I can use unit language and basic facts to solve.

$3 \text{ ones} \div 3 = 1 \text{ one}$

$6 \text{ tenths} \div 3 = 2 \text{ tenths} = 0.2$

$9 \text{ hundredths} \div 3 = 3 \text{ hundredths} = 0.03$

$3 \text{ units} = 3.69$

$1 \text{ unit} = 3.69 \div 3$

$1 \text{ unit} = 1.23$

*The toy car weighs 1.23 kg.*

### G5-M1-Lesson 14

1. Draw place value disks on the place value chart to solve. Show each step using the standard algorithm.

$$4.272 \div 3 = \underline{1.424}$$

4.272 is divided into 3 equal groups. There is 1.424 in each group.

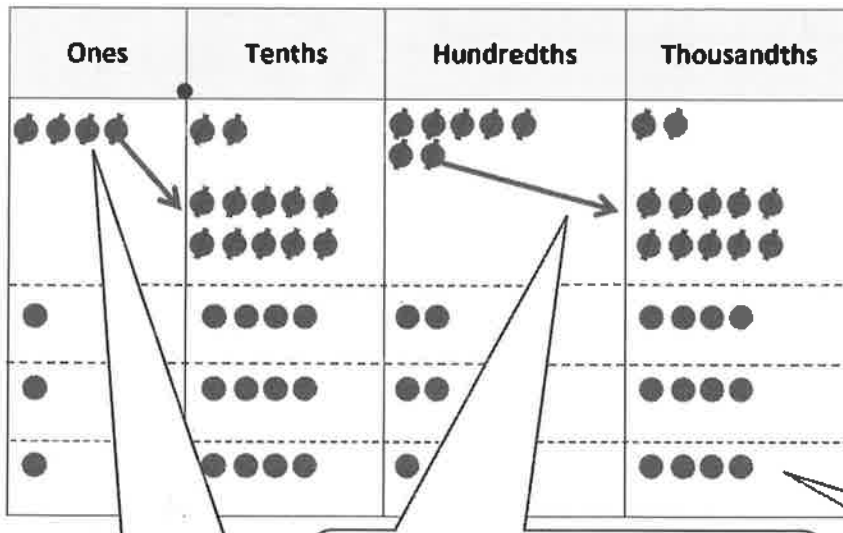

$$\begin{array}{r}
 1.424 \\
 3 \overline{) 4.272} \\
 \underline{- 3} \phantom{00} \\
 12 \phantom{00} \\
 \underline{- 12} \phantom{00} \\
 07 \phantom{00} \\
 \underline{- 6} \phantom{00} \\
 12 \phantom{00} \\
 \underline{- 12} \phantom{00} \\
 0
 \end{array}$$

When I share 4 ones equally with 3 groups, there is 1 one in each group and 1 one remaining.

In order to continue sharing, or dividing, I'll exchange the 1 remaining hundredth for 10 thousandths.

In each group, there is 1 one 4 tenths 2 hundredths 4 thousandths, or 1.424.

2. Solve  $15.704 \div 4$  using the standard algorithm.

15.704 is divided into 4 equal groups. There is 3.926 in each group.

As I work, I'm visualizing the place value chart and thinking out loud. "We had 15 ones and shared 12 of them. 3 ones remain. I can change those 3 ones for 30 tenths, which combined with the 7 tenths in the whole, makes 37 tenths. Now I need to share 37 tenths equally with 4 groups. Each group gets 9 tenths."

$$\begin{array}{r}
 3.926 \\
 4 \overline{) 15.704} \\
 \underline{- 12} \phantom{00} \\
 37 \phantom{00} \\
 \underline{- 36} \phantom{00} \\
 10 \phantom{00} \\
 \underline{- 8} \phantom{00} \\
 24 \phantom{00} \\
 \underline{- 24} \phantom{00} \\
 0
 \end{array}$$

When completing the division, I need to be sure to line up the place value units carefully—the tens with the tens, the ones with the ones, etc.

3. Mr. Huynh paid \$85.44 for 6 pounds of cashews. What's the cost of 1 pound of cashews?

I'll draw a tape diagram and label it \$85.44. Then I'll cut it equally into 6 units.



1 pound = ?

To find the cost of 1 pound of cashews, I'll divide \$85.44 by 6.

6 units = \$85.44  
1 unit =  $\$85.44 \div 6$   
= \$14.24

I'll solve using the long division algorithm.

$$\begin{array}{r}
 14.24 \\
 6 \overline{) 85.44} \\
 \underline{- 6} \phantom{0} \\
 25 \\
 \underline{- 24} \\
 14 \\
 \underline{- 12} \\
 24 \\
 \underline{- 24} \\
 0
 \end{array}$$

*The cost of 1 pound of cashews is \$14.24.*

### G5-M1-Lesson 15

1. Draw place value disks on the place value chart to solve. Show each step in the standard algorithm.

$$5.3 \div 4 = \underline{1.325}$$

5.3 is divided into 4 equal groups  
There is 1.325 in each group.

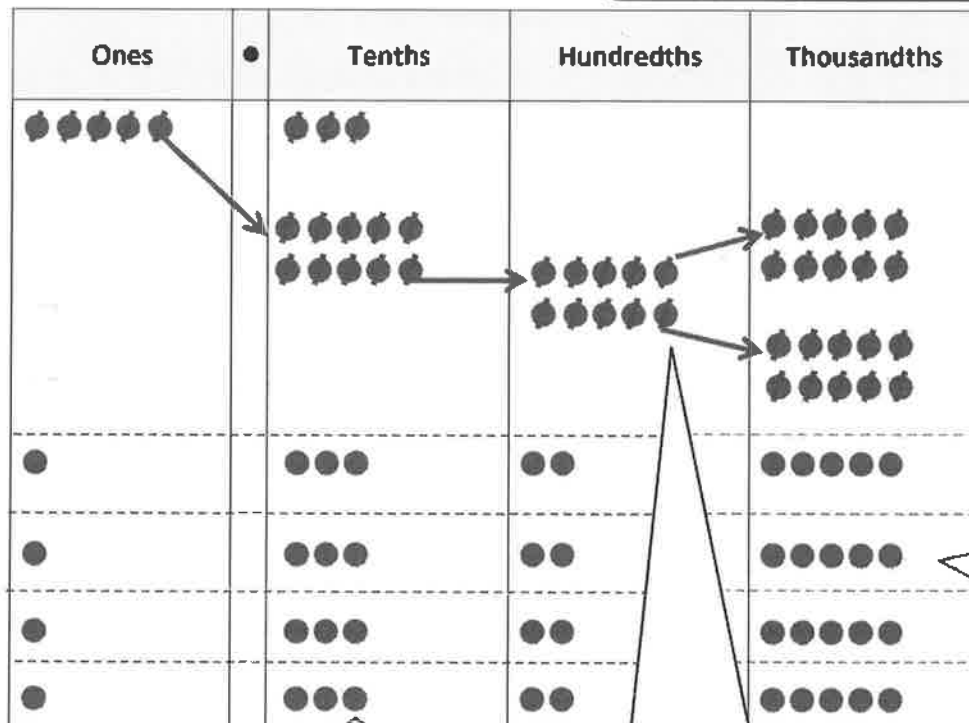

$$\begin{array}{r}
 1.325 \\
 4 \overline{) 5.300} \\
 \underline{- 4} \phantom{00} \\
 13 \phantom{0} \\
 \underline{- 12} \phantom{0} \\
 10 \\
 \underline{- 8} \phantom{0} \\
 20 \\
 \underline{- 20} \\
 0
 \end{array}$$

When I share 13 tenths equally with 4 groups, there are 3 tenths in each group, and 1 tenth remains.

In order to continue sharing, or dividing, I'll exchange the 2 remaining hundredths for 20 thousandths.

In each group, there is 1 one 3 tenths 2 hundredths 5 thousandths, or 1.325.

2. Solve using the standard algorithm.

$$9 \div 5 = \underline{1.8}$$

9 is divided into 5 equal groups. There is 1.8 in each group.

$$\begin{array}{r}
 1.8 \\
 5 \overline{) 9.0} \\
 \underline{- 5} \phantom{0} \\
 40 \\
 \underline{- 40} \\
 0
 \end{array}$$

In order to continue dividing, I'll rename the 4 remaining ones as 40 tenths.  
40 tenths  $\div$  5 = 8 tenths

3. Four bakers shared 5.4 kilograms of sugar equally. How much sugar did they each receive?

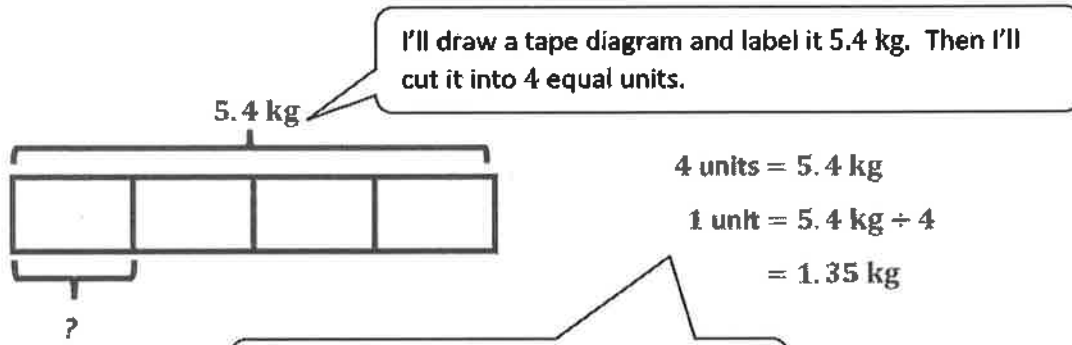

$$4 \text{ units} = 5.4 \text{ kg}$$

$$1 \text{ unit} = 5.4 \text{ kg} \div 4$$

$$= 1.35 \text{ kg}$$

To find the amount of sugar each baker will receive, I'll divided 5.4 kg by 4.

$$\begin{array}{r}
 1.35 \\
 4 \overline{) 5.40} \\
 \underline{- 4} \phantom{0} \\
 14 \\
 \underline{- 12} \\
 20 \\
 \underline{- 20} \\
 0
 \end{array}$$

I'll solve using the long division algorithm.

*Each baker received 1.35 kilograms of sugar.*

### G5-M1-Lesson 16

1. A comic book costs \$6.47, and a cookbook costs \$9.79.
  - a. Zion buys 5 comic books and 3 cookbooks. What is the total cost for all of the books?

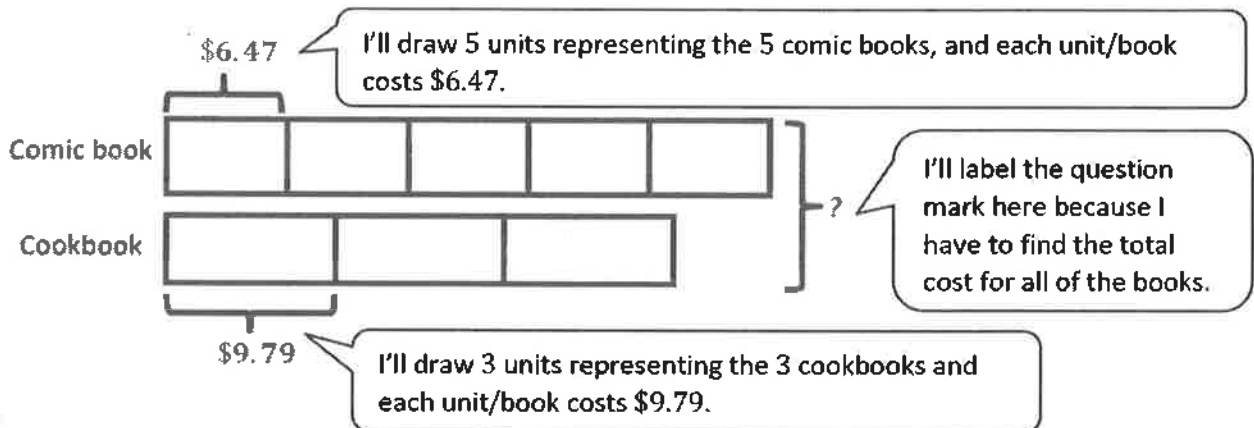

**Comic book:**

1 unit = \$6.47

5 units =  $5 \times \$6.47 = \$32.35$

I'll find the total cost of the 5 comic books by multiplying 5 times \$6.47.

	6 ones	+ 4 tenths	+ 7 hundredth
5	$5 \times 6$ ones	$5 \times 4$ tenths	$5 \times 7$ hundredths

30 ones + 20 tenths + 35 hundredths = 32.35

**Cookbook:**

1 unit = \$9.79

3 units =  $3 \times \$9.79 = \$29.37$

I'll find the total cost of the 3 cookbooks by multiplying 3 times \$9.79.

	9 ones	+ 7 tenths	+ 9 hundredth
3	$3 \times 9$ ones	$3 \times 7$ tenths	$3 \times 9$ hundredths

27 ones + 21 tenths + 27 hundredths = 29.37

The total cost of all the books is \$61.72.

$$\begin{array}{r} 32.35 \\ + 29.37 \\ \hline 61.72 \end{array}$$

I'll add the total cost of 5 comic books and the total cost of 3 cookbooks together to find the total cost of all 8 books.

- b. Zion wants to pay for all the books with a \$100 bill. How much change will he get back?

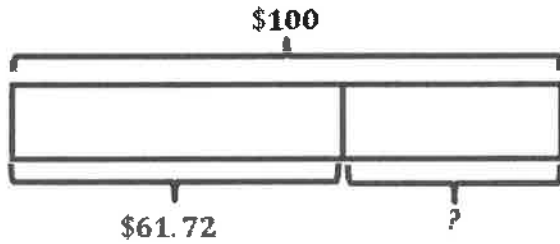

$$\$100 - \$61.72 = \$38.28$$

Zion will get \$38.28 back in change.

$$\begin{array}{r}
 099910 \\
 \cancel{A} \cancel{0} \cancel{0} \cancel{0} \cancel{0} \\
 - 61.72 \\
 \hline
 38.28
 \end{array}$$

I'll subtract \$61.72 from \$100 to find Zion's change.

2. Ms. Porter bought 40 meters of string. She used 8.5 meters to tie a package. Then she cuts the remainder into 6 equal pieces. Find the length of each piece. Give the answer in meters.

I'll draw a tape diagram to represent the string Ms. Porter bought and label the whole as 40 m.

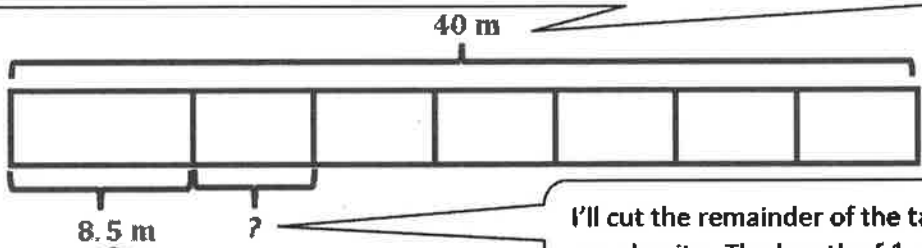

I'll cut out a small part representing the string needed for tying the package and label it 8.5 m.

I'll cut the remainder of the tape into 6 equal units. The length of 1 unit represents the length of each piece of string.

$$40 \text{ m} - 8.5 \text{ m} = 31.5 \text{ m}$$

$$\begin{array}{r}
 3910 \\
 \cancel{A} \cancel{0} \cancel{0} \\
 - 8.5 \\
 \hline
 31.5
 \end{array}$$

I can subtract 8.5 from 40 to find the length of the remaining string.

$$\begin{aligned}
 6 \text{ units} &= 31.5 \text{ m} \\
 1 \text{ unit} &= 31.5 \text{ m} \div 6 = 5.25 \text{ m}
 \end{aligned}$$

I can divide 31.5 by 6 to find the length of each piece of string.

$$\begin{array}{r}
 5.25 \\
 6 \overline{) 31.50} \\
 - 30 \phantom{0} \\
 \hline
 15 \\
 - 12 \\
 \hline
 30 \\
 - 30 \\
 \hline
 0
 \end{array}$$

Each piece of string is 5.25 meters.