

WHAT IS FORM?

- Form is an element of art
- Forms are closed spaces
- Forms are either geometric or free form.



GEOMETRIC FORMS EXAMPLES

CUBE

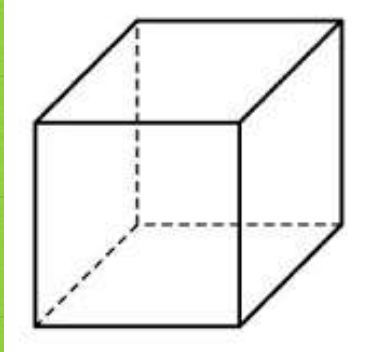

CONE

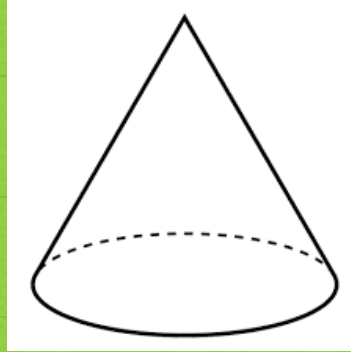

SPHERE

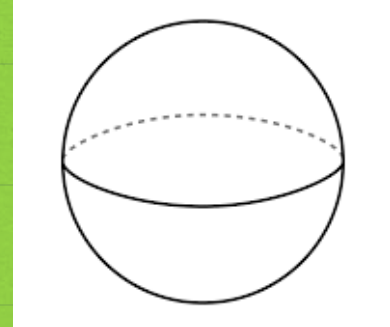

IS IT A SHAPE OR A FORM?

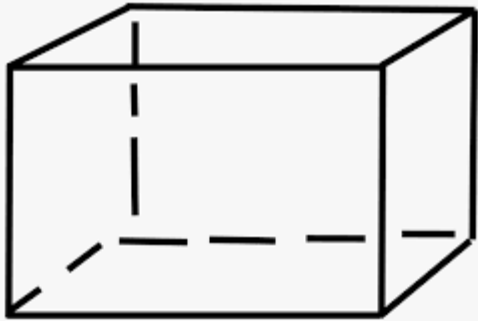



CLICK THE LINK AND WATCH TO LEARN HOW TO DRAW GEOMETRIC FORMS

[HTTPS://WWW.YOUTUBE.COM/WATCH?V=_XJ1A5iO8vc](https://www.youtube.com/watch?v=_XJ1A5iO8vc)

DRAW YOUR OWN GEOMETRIC FORM:

1. PICK ONE OF THE GEOMETRIC FORMS AND PRACTICE DRAWING YOUR OWN WITH PAPER AND PENCIL.
2. FIND A GEOMETRIC FORM IN THE ROOM

ZAHA HADID'S DESIGNS



Olympics Aquatic Centre, London



MAKE YOUR OWN FREE FORM:

1. FIND OBJECTS AROUND THE ROOM TO MAKE YOUR OWN FREE FORM.

(THIS CAN BE CARDBOARD FOOD BOXES, VEGETABLE CANS, LEGOS, STICKS FROM OUTSIDE, TOYS, PLAYDOUGH, ANYTHING YOU FIND)

1. MAKE AN ANIMAL WITH THE OBJECTS YOU FIND.



TALK ABOUT IT WITH A PARTNER

1. What is your artwork about?
2. What is unusual/different about it?
3. How does it make you feel?