

Physical Science EOCT Review Key Concepts

Section 1: Motion, Forces, and Energy

Motion and Force: SPS 8. Students will determine relationships among force, mass, and motion.

Energy: SPS 7. Students will relate transformations and flow of energy within a system.

Speed and Velocity: SPS 8a. Calculate velocity and acceleration.

- An object is in motion when it is continuously changing its position relative to a reference point. *Speed* is how fast an object is going with respect to an object. *Velocity* is a measure of the speed *in a given direction*. You can say the top speed of an airplane is 300 kilometers per hour (kph). But its velocity is 300 kph in a northeast direction.
- Calculating speed or velocity
 - Speed = distance/ time ($s = d/t$) and velocity = distance/time in a particular direction ($v = d/t$)
 1. Bob travels 300 km in 10 hrs towards the store. Speed = 300 km / 10 hr = 30km/hr
 2. Ashley swims 50 m in 10 seconds. Speed = 50 m / 10 s = 5 m/s

Acceleration: SPS 8a. Calculate velocity and acceleration.

Acceleration is the increase of velocity over a period of time. Deceleration is the decrease of velocity.

$$\text{Acceleration} = \text{final velocity} - \text{initial velocity}/\text{time}$$

$$a = \frac{v_f - v_i}{t}$$

Changing direction can also cause acceleration (or deceleration) because the velocity in that direction has changed.

Calculate the acceleration:

1. A train traveling 20 meter per second takes 10 seconds to stop. $[0\text{m/s} - 20\text{m/s}]/10\text{s} = -2 \text{ m/s}^2$
2. A boy gains a speed of 5 m/s after running for 20 seconds. $[5 \text{ m/s} - 0 \text{ m/s}]/20 \text{ s} = 0.25 \text{ m/s}^2$

Newton's Laws of Motion: SPS 8b. Apply Newton's 3 Laws to everyday situations by explaining the following: inertia, relationship between force, mass, and acceleration, and equal and opposite forces.

- Newton's 1st Law: The first law says that an object at rest tends to stay at rest, and an object in motion tends to stay in motion, with the same direction and speed unless acted on by unbalanced force. (Also called the Law of Inertia)
- Newton's 2nd Law: defines the relationship between acceleration, force, and mass. As the mass goes up, the same force will cause an object to have less acceleration. This law is often stated mathematically as $F = \text{mass} \times \text{acceleration}$.
- Newton's 3rd Law: The third law says that for every action (force) there is an equal and opposite reaction (force). Forces are found in pairs.

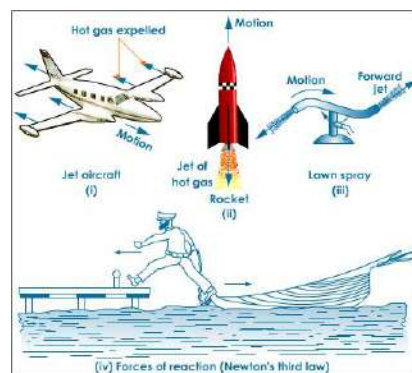

Forces and Gravitation: SPS 8c. Relate falling objects to gravitational force.

- Gravity is the force that pulls objects toward the Earth. It is affected by mass and distance.

$$\text{The equation for the force of gravity is } \mathbf{F} = \mathbf{mg}.$$

- Acceleration due to gravity

The acceleration due to the force of gravity on Earth is $g: 9.8 \text{ m/s}^2$

- Weight

The weight of an object is the measurement of the force of gravity on that object. You weigh something on a scale, according to the force that the Earth pulls it down: $w = \mathbf{mg}$; where w is the weight in Newtons (N).

Mass and Weight: SPS 8d. Explain the difference between mass and weight.

Mass is a measure of how much matter an object has. Weight is a measure of how strongly gravity pulls on that matter. Mass is constant, but the weight may change.

Mass vs. Weight

Weight and mass are related in that the weight of an object is proportional to its mass. The greater the mass of a body the greater the weight and the harder it is to lift.

Weight is a force. Mass is the quantity of matter in an object.

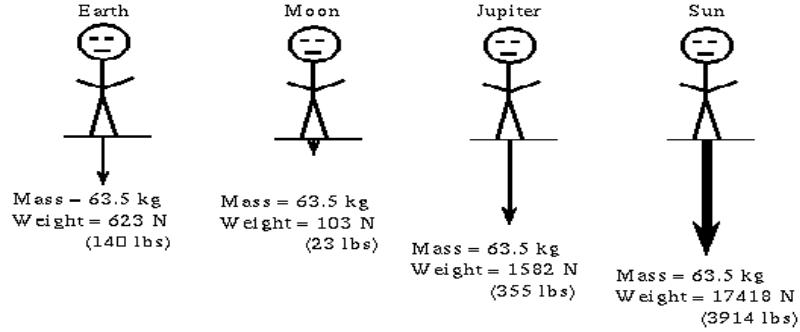

Work and Mechanical Advantage: SPS 8e. Calculate amounts of work and mechanical advantage using simple machines.

Machines are devices that make work easier. Machines are those able to do **work** ($W = F \cdot d$) with just one movement of the machine. Compound machines require more than one movement to do work. There are six **simple machines**: lever, pulley, wheel and axle, inclined plane, wedge, and screw.

Since a machine has parts that are in contact with other things, friction is produced. So in the real world, a machine can never be 100% efficient.

Efficiency = Work output / Work input x 100%

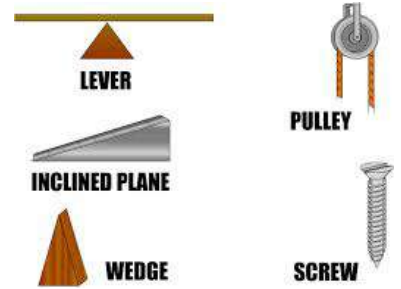

MA = Resistance force (F_r) / Effort force (F_e) or **MA = Input distance (slope) / Output distance (height)**

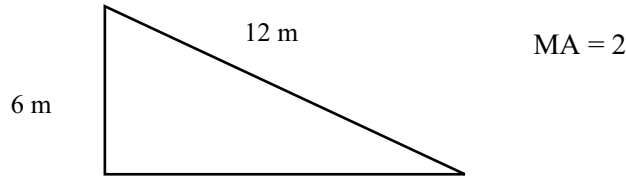
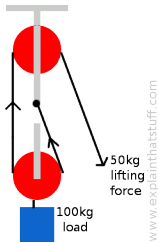

Energy: SPS 7. Students will relate transformations and flow of energy within a system. SPS 7a. Identify energy transformations within a system (e.g. lighting of a match.)

Types of Energy	
Potential Energy	Stored energy due to position
Kinetic Energy	Energy of motion
Chemical Energy	A form of potential energy and it is possessed by things such as food, fuels and batteries
Thermal Energy	Heat
Mechanical Energy	Sum of potential and kinetic energy in a system
Electromagnetic Energy	The energy source required to transmit information (in the form of waves) Some types of electromagnetic energy include: radio waves, microwaves, infrared waves, visible light, ultraviolet light, x-rays, and gamma rays. All electromagnetic forms of energy travel at the speed of light which is very fast.
Gravitational Potential Energy	Energy stored within an object due to its height above the surface of the Earth.

Energy Transformation	
Consuming food	The body utilizes the <i>chemical</i> energy in the bonds of the food and transforms it into <i>mechanical</i> energy.

Car engine	Converts the chemical energy of gas into the mechanical energy of engine movement.
Light bulb	Converts the chemical energy of the bulb into electromagnetic radiation, or light.
Windmills	Converts the energy of the wind and into mechanical energy in the movement of the turbine blades, which is then converted to electrical energy
Solar panels	Transfer light energy from the sun into electrical energy.

Thermal Energy: SPS 7a. Identify energy transformations within a system (e.g. lighting of a match.)

Method of heat transfer	Description	Example
Conduction	Heat transfer by direct contact	Burning your hand by touching a hot pan.
Convection	Heat transfer through fluids (gas or liquid)	Wind currents. Heating and cooling system in our homes and buildings.
Radiation	Heat transfer through open space (vacuum)	The hood of a car getting hot on a summer day.

SPS 7b. Investigate molecular motion as it relates to thermal energy changes in terms of conduction, convection, and radiation.

Insulator	Conductor
Material that does not allow heat to pass easily.	Material that allows heat to pass easily.
Examples: wood, plastic, rubber, air, fiberglass, fleece, thermal underwear	Examples: Metals such as copper, silver, gold, aluminum
Poor conductor	Poor insulator

Heat travels from a warmer material to a colder material.

SPS 7c. Determine the heat capacity of a substance using mass, specific heat, and temperature.

Specific Heat Capacity Formula for calculating heat: $Q = mc\Delta T$	
Quantity	Unit
Q is heat	Joules (J)
m is mass	Grams (g)
c is specific heat	Joules/gram· ° Celsius
ΔT is change in temperature Final temp- initial temp	° Celsius

Section 2: Waves, Electricity, and Magnetism

Waves: SPS9- Students will investigate the properties of waves

Electricity and Magnetism: SPS10. Students will investigate the properties of electricity and magnetism.

SPS9a. Recognize that all waves transfer energy.

A wave is a disturbance that **transfers energy** through matter or through space. Some waves, like sound waves, must travel through matter while others, like light, can travel through space.

SPS9e. Relate the speed of sound to different mediums.

Wave	
Mechanical (requires a medium: solid, liquid, or gas)	Electromagnetic (does not require a medium/ can travel in a vacuum)

Sound waves require air (gas)	Radio waves
Water waves require water (liquid)	Infrared Light
Earthquake (seismic waves) requires earth (solid)	Gamma rays

Waves can be either longitudinal (compressional) or transverse.



Compressional Wave

Ex: sound waves
Parallel movement

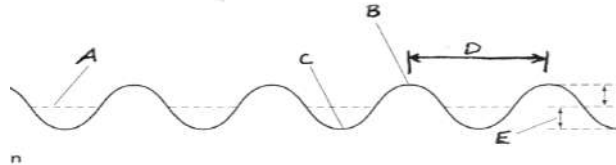

Transverse Wave

Ex: light waves
Perpendicular movement

Parts of a Transverse Wave:

- A. Amplitude - the height of a wave above or below the midline.
- B. Crest - the peak or top of the wave.
- C. Midline (normal) - original position of the medium before the waves move through it.
- D. Trough - the lowest point of the wave.
- E. Wavelength - the distance between two peaks.

Relating Frequency and Wavelength: SPS 9b. Relate frequency and wavelength to the electromagnetic waves and mechanical waves.

Frequency is how fast the wave is moving. If you stand in one spot and watch a wave go by, it is the number of crests that go by in a second.

Waves with long wavelengths have a low frequency. Waves with short wavelengths have a high frequency. The higher the frequency, the more energy a wave has.

The speed or velocity of a wave depends on the wavelength and the frequency. The formula for wave speed is:
Speed = wavelength x frequency

THE ELECTROMAGNETIC SPECTRUM: SPS 9c. Compare and contrast the characteristics of electromagnetic and mechanical (sound waves).

The electromagnetic spectrum is a set of electromagnetic waves in order of wavelength and frequency - a long wavelength has a low frequency, a short wavelength has a high frequency. Electromagnetic waves can travel through space. They do not need to travel through a medium like air or water, though they can.

The Spectrum in Order (“Rabbits Mate In Very Unusual Xciting Gardens”)

Least Energy Most Energy	Radio Waves	lowest frequency and longest wavelength, used for communication (radio and TV)
	Microwaves	used in cooking and for RADAR
	Infrared Waves	cannot be seen, felt as heat, “below” red, used for cooking, medicine, night sight
	Visible Light	portion of the spectrum that your eye is sensitive to, consists of seven colors (ROYGBIV), red has the lowest frequency/energy and violet has the highest frequency/energy
	Ultraviolet Waves	present in sunlight, “beyond” violet, energy is enough to kill living cells, used for sterilization
	X-Rays	energy is enough for photons to pass through the skin, for medicine
	Gamma Rays	highest frequency, shortest wavelength, certain radioactive materials emit them, have tremendous ability to penetrate matter, used in the treatment of cancer

Wave Interactions: SPS 9d. Students will investigate the phenomenon of reflection, refraction, diffraction, and interference.

When a wave hits a piece of matter, the wave can be absorbed or it can be reflected.

Reflection

- The bouncing back after a wave strikes an object that does NOT absorb the wave's energy.
- **The Law of Reflection states that the angle of the incidence is equal to the angle of reflection. In other words, the angle that it hits the object at will be the same angle, in the opposite direction, that the waves leaves the surface**

Refraction

- The bending of waves due to a change in speed. This time the wave is absorbed and not reflected.
- Waves move at different speeds in different types of matter. Temperature can also affect the speed of a wave.
- Examples include prisms (bends white light into its component colors), lenses like glasses and contacts, and a mirage.

Diffraction

- The bending of waves around a barrier. When it encounters a barrier, the wave can go around it.
- Electromagnetic waves, sound waves, and water waves can all be diffracted. Diffraction is important in the transfer of radio waves. Longer AM wavelengths are easier to diffract than shorter FM wavelengths. That is why AM reception is often better than FM reception around tall buildings and hills.
- Examples include sound waves bending to come around a corner, or underneath a door

Interference

- The phenomenon which occurs when two waves meet while traveling along the same medium. The interference of waves causes the medium to take on a shape which results from the net effect of the two individual waves.
- When two waves' crests or troughs combine, there is an additive effect – this is called constructive interference. When one wave's crest and another's trough combine, there is a subtractive effect – this is called destructive interference.

Constructive Interference

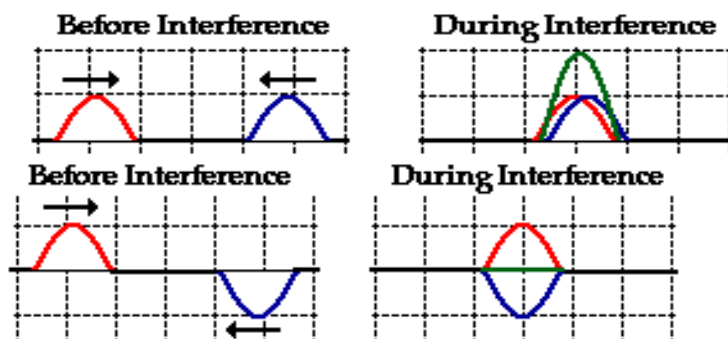

Destructive Interference

SPS 9f. Explain the Doppler Effect in terms of everyday interactions.

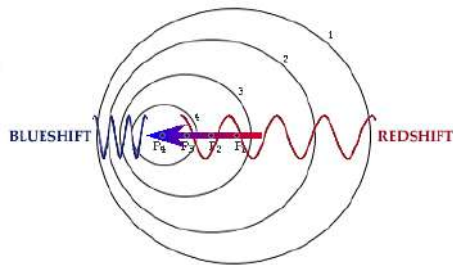

Doppler Effect – As the ambulance approaches, the sound waves from its siren are compressed towards the observer. The intervals between waves diminish, which translates to an increase in frequency. As the ambulance recedes, the sound waves are stretched relative to the observer, causing the siren's pitch to decrease. By the change in pitch of the siren, you can determine if the ambulance is coming nearer or speeding away. If you could measure the **rate** of change of pitch, you could also estimate the ambulance's speed

Electricity & Magnetism:

Electricity and Magnetism: SPS10: Students will investigate the properties of electricity and magnetism

SPS10a. Investigate static electricity in terms of friction, induction, and conduction.

Static - some of the outer electrons are held very loosely. They can move from one atom to another. An atom that loses electrons has more positive charges (protons) than negative charges (electrons). It is positively charged. An

atom that gains electrons has more negative than positive particles. It has a negative charge. A charged atom is called an "ion."

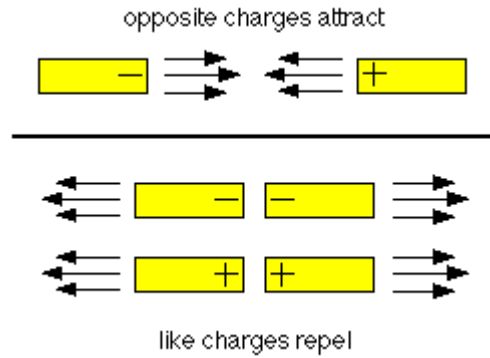

Static electricity is the imbalance of positive and negative charges.

Current Electricity: SPS10b Explain the flow of electrons in terms of alternating and direct current; the relationship between voltage, resistance and current; simple, series, and parallel circuits.

To make "something" (refrigerator, light, computer, radio controlled car, sewing machine.....) turn on we need:

- an appropriate source of electricity
- metal wires insulated with plastic
- a switch
- and the thing

We connect them in a distinct sequence for the thing to work.

The source is a **source of energy**.

- In the case of **DC (Direct Current – (battery)** current flows in one direction only), it has a limited life then is unusable so we throw it away.

- In the case of **AC (alternating Current – (wall plug)** current flows back and forth (changes direction)) the power company provides the electricity, it is far closer to limitless as an energy source.

The flow of electrons is called a current, an electric current. They flow from high to low energy in response to an electric field established in the wires and CD player- a region of influence on charges by other charges.

The formula for calculating voltage is: $V = I \times R$

Quantity	Symbol	Unit of Measurement	Unit Abbreviation
Current	I	Ampere ("Amp")	A
Voltage	E or V	Volt	V
Resistance	R	Ohm	Ω

Series vs. Parallel:

There are 2 ways to connect multiple devices to a power source (e.g. speakers to an amplifier), series and parallel.

Speakers in series

In a series circuit (example to the left), the current must flow through one device to get to the next device. This means that the rate of **current flow** through all devices is the **same**. The voltage across each device depends on its impedance/resistance of each device and the current flowing through the circuit. When adding more components in a series circuit, the current flow decreases, if the applied voltage remains constant.

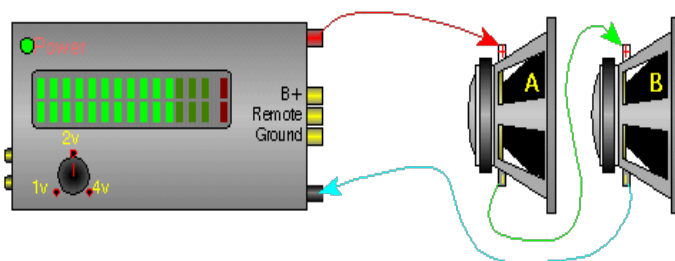

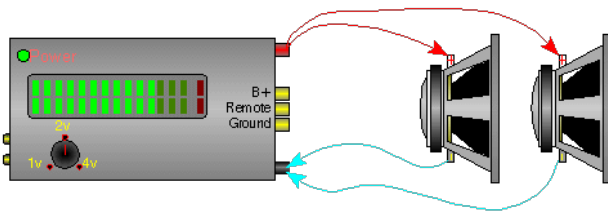

Speakers in parallel

In a parallel circuit (example to the right), each device is directly connected to the power source. This means that **each device** receives the **same voltage**. The amount of current flowing through each device is dependent on the impedance/resistance of that particular device.

Magnetism

SPS 10c: Investigate applications of magnetism and/or its relationship to the movement of electrical charge as it relates to electromagnets; simple motors; and permanent magnets.

Magnetism is a universal force like gravity. A magnet always has two poles - north and south. Like poles repel each other and opposite poles attract. There is a magnetic field around a magnet and the invisible lines of force run from one pole to the other.

A permanent magnet is a magnet that is permanent, in contrast to an electromagnet, which only behaves like a magnet when an electric current is flowing through it. A magnetic field can be produced using a current through a wire and a piece of metal that can be magnetized. Electricity and magnetism are related. Electricity can produce a magnetic field and magnetism can produce an electric current.

Electromagnetism

An electromagnet is a temporary magnet. As long as there is a current flowing, a magnetic field is present. A simple electromagnet consists of a battery, copper wire, and an iron nail. The strength of the electromagnet depends on the number of turns in the wire coil and the size of the iron core. *The greater the number of turns, the stronger the magnetic field that is produced.*

Device	Energy conversion	Example
Electric motor	Converts electric energy to mechanical energy	Battery
Generator	Converts mechanical energy to electrical energy	Power company (water turbine)

Electromagnet



You can increase the strength of an electromagnet by increasing the current flowing through the wire or by increasing the number of coils.

Section 3: Atomic Theory and the Periodic Table

SPS 5. Students will compare and contrast the phases of matter as they relate to atomic and molecular motion.

States (Phases) of Matter: SPS 5a. Compare and contrast the atomic/molecular motion of solids, liquids, gases and plasmas.

States (Phases) of Matter

Common States of Matter	Volume	Shape	Molecular Attraction	Examples
Solids	yes	yes	strong	Desk, sand, ice
Liquids	yes	no	medium	Water
Gases	no	no	weak	Carbon dioxide

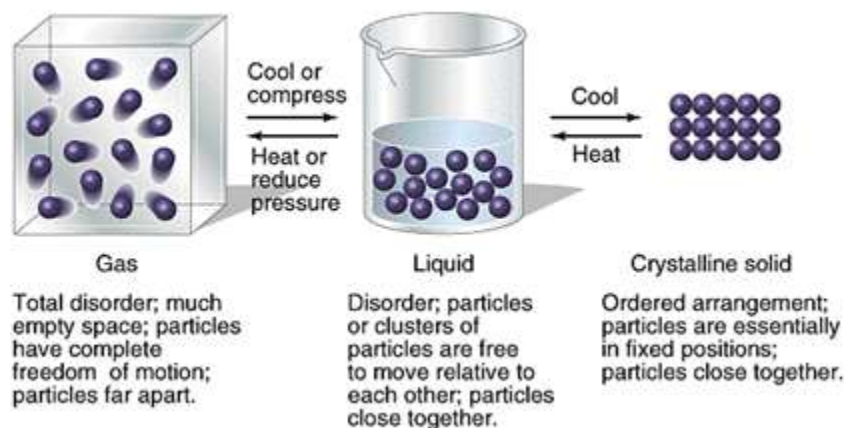

Gas Laws SPS 5b. Relate temperature, pressure, and volume of gases to the behavior of gases.

- Gases are easily expandable and compressible unlike solids and liquids. Gases have a measurement of pressure. Gas has a low density because its molecules are spread apart over a large volume. A gas will fill whatever container that it is in. An example of this is a bottle of ammonia being opened in a room and the smell traveling throughout the room.



Boyle's Law states the volume of a definite quantity of dry gas is inversely proportional to the pressure, provided the temperature remains constant.

Pressure increase = volume decrease Pressure decrease = volume increase

Charles's Law can be stated as the volume occupied by any sample of gas at a constant pressure is directly proportional to the absolute temperature.

Temperature increase = volume increase Temperature decrease = volume decrease

Gay-Lussac's Law states that the pressure of a sample of gas at constant volume, is directly proportional to its temperature in Kelvin.

Temperature increase = pressure increase Temperature decrease = pressure decrease

Atomic Theory

SPS1. Students will investigate our current understanding of the atom.

- Examine the structure of the atom in terms of:
 - proton, electron, and neutron locations.
 - atomic mass and atomic number.
 - atoms with different numbers of neutrons (isotopes).
 - explain the relationship of the proton number to the element's identity.
- Compare and contrast ionic and covalent bonds in terms of electron movement.

Atoms

All matter is made up of atoms. An atom is like a tiny solar system. In the center of the atom is the nucleus which is a cluster of protons and neutrons. The **protons** have a positive electric charge while the **neutrons** are electrically neutral. The nucleus makes up almost all of an atom's mass or weight. Whirling at fantastic speeds around the nucleus are smaller and lighter particles called **electrons** which have a negative electric charge.

An atom has the same number of electrons (- charge) and protons (+ charge) to make the atom electrically neutral. An extremely powerful force, called the strong nuclear force, holds the protons together in the nucleus as they naturally repel one another electrically (like charges repel / unlike charges attract). The neutrons are neutral. Their purpose in the nucleus is to bind protons together. Because the protons all have the same charge and would naturally repel one another, the neutrons act as "glue" to hold the protons tightly together in the nucleus

The **atomic number** of an element is what distinguishes it from all other elements. An atom's atomic number is the **number of protons** there are in the nucleus. Hydrogen's atomic number is 1. Helium's atomic number is 2. Any atom that has an atomic number of 1 is a hydrogen atom no matter how many electrons or neutrons the atom has.

The **mass number** is the number of neutrons added to the number of protons - in other words, the **total number of particles in the nucleus**. The mass number of the most common **isotope** can be obtained from the periodic table. If you take the decimal number on the periodic table and round it to the nearest whole number, you have the mass number. For example the atomic weight of Iron (Fe) is 55.847. When rounded it gives a mass number of 56.

The atomic number of Fe is 26 so most Fe atoms have 30 neutrons. You find this by subtracting the atomic number 26 (#of protons) from the mass number 56 (the total # of particles) so $56 - 26 = 30$. In addition, all neutral Fe atoms have 26 protons and 26 electrons (remember the number of protons + should = the number of electrons -). Atoms of the same element with a different number of neutrons are called **isotopes**. The most common isotope of an element is the one that is on the periodic table.

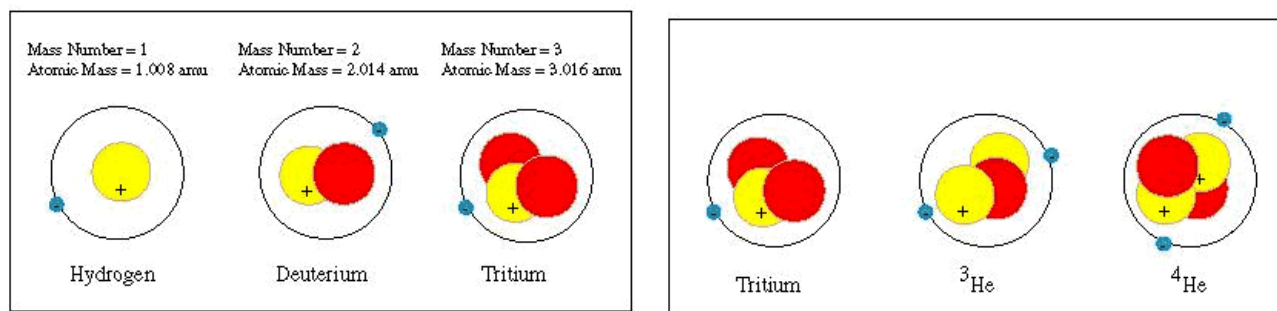

An atom is an extremely small particle of matter that retains its identity during chemical reactions.

An ion is an electrically charged particle obtained from an atom or chemically bonded group of atoms by adding or removing electrons. This means that an ion is the result of taking away, or adding, electrons to an atom or a chemically bonded group of atoms. By taking away, or adding, these electrons, the particle takes on an electrical charge. Atoms are electrically neutral as they contain an equal number of positive and negative charges. An atom that adds an extra electron to it becomes a negatively charged ion. This type of ion is called an anion. An atom which loses one or more of its electrons now has a positive charge, and is called a cation. For example, a sodium atom can lose one of its electrons and form a sodium cation. Now, instead of being Na, it would be Na^+ . This means that the sodium atom has an overall positive charge of +1. Another example would be a neutral atom of Sulfur, S. If this atom of S were to gain two electrons it would become S^{2-} . The sulfur atom would now have a total negative charge of -2. It has 16 protons and 18 electrons.

A molecule is a definite group of atoms that are chemically bonded together. They are tightly connected by attractive forces. A molecular formula is a chemical formula that gives the exact number of different types of atoms in a molecule. Some simple molecular substances are carbon dioxide, CO_2 ; ammonia, NH_3 ; and water, H_2O . The atoms that are in a molecule are not just stuffed together without any order. The atoms are chemically bonded to one another in order to form a definite arrangement. A structural formula is a chemical formula which shows how the atoms are bonded to one another to form a molecule. A good example is the structural formula for water, H-O-H. Those two horizontal lines connecting the H with the O (hydrogen and oxygen) represent the chemical bonds joining the atoms.

Positive and Negative Ions

All atoms are composed of and equal number of protons (in the nucleus) and electrons (orbiting around the nucleus). Apart from Hydrogen atoms, all atoms also contain Neutrons in their nuclei. Neutrons have no electric charge. Protons have a positive electric charge: P^+ and electrons have a negative electric charge: e^-

* This means that if an atom has equal numbers of protons and electrons it will have no overall charge.

* When an atom loses an electron it must have more protons than electrons so it will have an overall positive charge: these are all positive ions (cations). You will find these elements in the first column of the periodic table, this is Group I. $\text{H}^+ \text{Li}^+ \text{Na}^+ \text{K}^+$

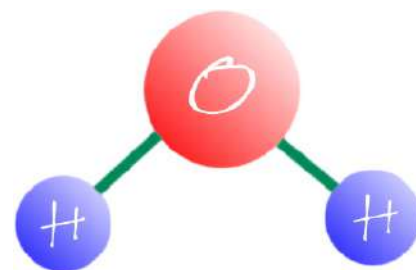

* The elements in Group II also make positive ions, but instead of losing a single electron, their atoms lose 2 electrons when they turn into ions: you will find these metals in the second column of your periodic table so they are Group II.

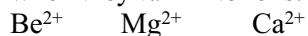

* I like Aluminum which is much more fun because its atoms always lose 3 electrons when they turn into ions: please don't bother to look for an element with 4+ because you will be wasting your time. Carbon and Silicon are found in Group IV, they form covalent compounds, not ionic ones.



* Negative ions come from non-metals, (or from non-metals combined with a metal). You will find the non-metals on the right hand side of your periodic table. First have a look at Group VIII, these are the Noble Gases; they do not make ions, they are inert or unreactive. This means that it is possible to have pure Neon (Argon, Krypton etc.) but it is not possible to make chemicals by reacting these elements with other elements. (Nobel chemistry prize winners and "A" Level chemistry students please note that this page is intended for GCSE students.)

* So now have a look at Group VII. Here we find some more easy ones. The elements in Group VII all form ions with a single negative charge (anions). This is because they contain one more electron than protons. Just to make you life a little more interesting (or difficult) chemists change the name of the substance to indicate whether it is an atom or ion they are talking about so Fluorine atoms can be turned into Fluoride ions by gaining one electron. Fluorine --- Fluoride, Chlorine --- Chloride, Bromine --- Bromide, Iodine --- Iodide, Sulphur --- Sulphide. $\text{F}^- \quad \text{Cl}^- \quad \text{Br}^- \quad \text{I}^-$

* Sulphides are rather nice chemicals; I like them because it is easy to make Hydrogen Sulphide gas from them; this is the smell of rotten eggs! S^{2-}

* It is also possible to find ions with 2 or 3 negative charges. $\text{N}^{3-} \quad \text{P}^{3-}$

Ionic & Covalent Bonds

SPS 1b. Compare and contrast ionic and covalent bonds in terms of electron movement.

A molecule or compound is made when two or more atoms form a chemical bond, linking them together. The two types of bonds are ionic bonds and covalent bonds.

* In ionic bonding, electrons are completely transferred from one atom to another. In the process of either losing or gaining negatively charged electrons, the reacting atoms form ions. The oppositely charged ions are attracted to each other by electrostatic forces, which are the basis of the ionic bond.

For example, during the reaction of sodium with chlorine:

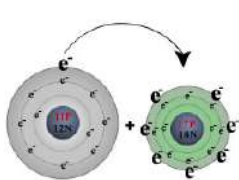

sodium (on the left) loses its one valence electron to chlorine (on the right),

Resulting in a positively charged sodium ion (left) and a negatively charged chlorine ion (right).

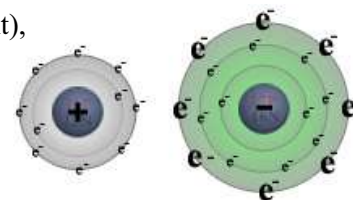

- The second major type of atomic bonding occurs when atoms **share electrons**. As opposed to ionic bonding in which a complete transfer of electrons occurs, covalent bonding occurs when two (or more) elements share electrons. **Covalent bonding** occurs because the atoms in the compound have a similar tendency for electrons (generally to gain electrons). This most commonly occurs when two nonmetals bond together. Because both of the nonmetals will want to gain electrons, the elements involved will share electrons in an effort to fill their valence shells. A good example of a covalent bond is that which occurs between two hydrogen atoms. Atoms of hydrogen (H) have one valence electron in their first electron shell. Since the capacity of this shell is two electrons, each hydrogen atom will "want" to pick up a second electron. In an effort to pick up a second electron, hydrogen atoms will react with nearby hydrogen (H) atoms to form the compound H₂. Because the hydrogen compound is a combination of equally matched atoms, the atoms will share each other's single electron, forming one covalent bond. In this way, both atoms share the stability of a full valence shell. If the electron is shared equally between the atoms forming a covalent bond, then the bond is said to be nonpolar. Usually, an electron is more attracted to one atom than to another, forming a polar covalent bond. For example, the atoms in water, H₂O, are held together by polar covalent bonds.

Radioactivity

SPS 3. Students will distinguish the characteristics and components of radioactivity.

- Differentiate among alpha and beta particles and gamma radiation.
- Differentiate between fission and fusion.
- Explain the process half-life as related to radioactive decay.
- Describe nuclear energy, its practical application as an alternative energy source, and its potential problems.

Fission & Fusion

Nuclear fission is the process used in the production of nuclear power. Fission involves splitting the nucleus of a heavy atom, such as uranium. This yields two or more lighter nuclei and a large amount of energy.

Fusion, on the other hand, is the combination of two hydrogen nuclei into one helium nucleus, under conditions of extreme heat and pressure. Fusion is the process by which energy is created in the sun

SPS 3c. Explain the process half-life as related to radioactive decay.

Radiation

* Radiation and radioactivity occur naturally in the physical world. All living beings require some kinds of radiation just to live. Light and heat, for example, are two basic forms of radiation necessary for all life on Earth.

* Radiation is a form of energy. Radioactivity is the spontaneous emission of energy from certain elements, and from other elements under special conditions, in the form of particles or electromagnetic waves.

Radioactivity

* The study of radioactivity begins with the atom. Tremendous amounts of energy are stored in the center, or nucleus, of an atom. Scientists have learned how to split atoms in a controlled process to capture the energy stored in them. When atoms are split, heat and radioactivity are produced. The intense heat produced when an atom is split can be used to turn water into steam to run turbines that produce electricity. This is the basis for nuclear power production.

The radiation produced from radioactive atoms is emitted in several forms, most commonly, alpha and beta particles, and gamma rays.

* Measuring radiation exposure and average exposures

➤ *Alpha particles* have the shortest range among these three types of radiation. They can travel only a few inches in the air and can be stopped easily by a sheet of paper or the outer layer of a person's skin. Alpha particles are harmful only if the radioactive source material is swallowed, inhaled, or absorbed into a wound.

➤ *Beta particles* are more penetrating than alpha particles. They can travel through the air for several feet, but their penetrating power, too, is limited. Although they can pass through a sheet of paper, materials such as a thin sheet of aluminum foil or glass can stop them. Like alpha particles, they cause their most serious effects if swallowed or inhaled.

Some radioactive material that emits beta particles could, for example, be attached to dust we might breathe in, or cling to food we might eat. In such cases, some of the material would leave the body through natural elimination processes. Some, however, may be retained in various organs where chemicals in living cells would be ionized and potentially damaged when the beta particles are emitted.

➤ *Gamma rays* are electromagnetic energy. Unlike alpha or beta particles and their relatively short ranges, gamma rays have much greater penetration power. They are more energetic than X-rays. This type of radiation requires shielding with such materials as concrete, lead, steel, or water. Water is used to shield workers from radiation emitted by spent nuclear fuel assemblies at nuclear power plants.

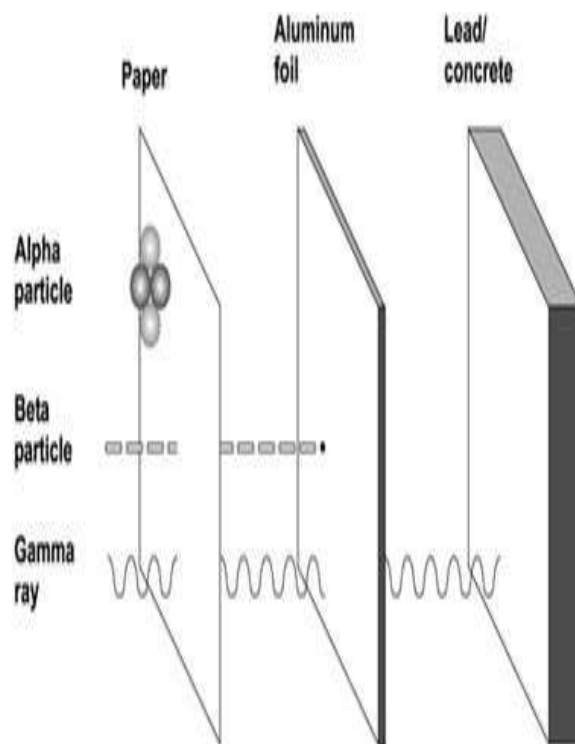

* **Radioactive decay** proceeds according to a principal called the **half-life**. The half-life ($T_{1/2}$) is the amount of time necessary for one-half of the radioactive material to decay. For example, the radioactive **element** bismuth (^{210}Bi) can undergo alpha decay to form the element thallium (^{206}Tl) with a reaction half-life equal to five days. If we begin an experiment starting with 100 g of bismuth in a sealed lead container, after five days we will have 50 g of bismuth and 50 g of thallium in the jar. After another five days (ten from the starting point), one-half of the remaining bismuth will decay and we will be left with 25 g of bismuth and 75 g of thallium in the jar. As illustrated, the reaction proceeds in halves, with half of whatever is left of the radioactive element decaying every half-life period.

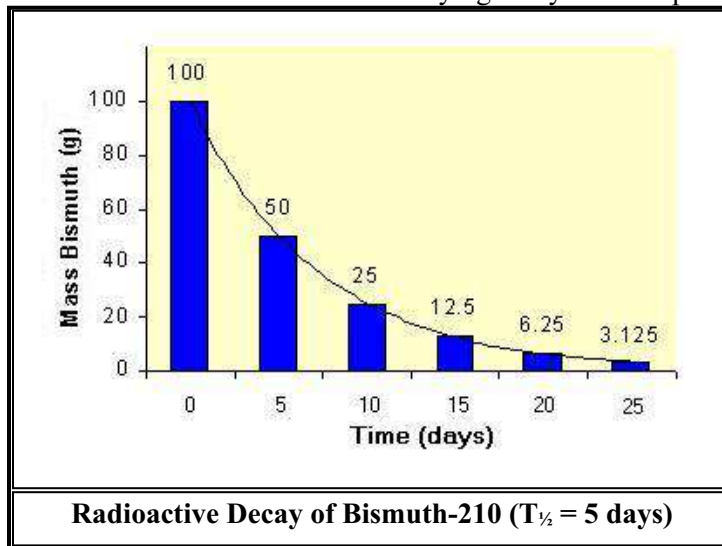

The fraction of **parent** material that remains after radioactive decay can be calculated by:

Half Life	% of parent material
1	50 %
2	25 %
3	12.5 %
4	6.25 %
5	3.125 %

When Formed $64/64=1$

1 half life $32/64=1/2$

2 half lives $16/64=1/4$

3 half lives $8/64=1/8$

4 half lives $4/64=1/16$

5 half lives $2/64=1/32$

6 half lives $1/64=1/64$

Decay of Radioactive Parent and build up of Stable Daughter Isotopes in a Rock

Section 5: Chemical Reactions and Properties of Matter

Density

DENSITY is a physical property of matter, as each element and compound has a unique density associated with it. Density defined in a qualitative manner as the measure of the relative "heaviness" of objects with a constant volume. For example: A rock is obviously denser than a crumpled piece of paper of the same size.

A styrofoam cup is less dense than a ceramic cup.

Density may also refer to how closely "packed" or "crowded" the material appears to be - again refer to the Styrofoam vs. ceramic cup.

Take a look at the two boxes below. Each box has the same volume. *If each ball has the same mass, which box would have more mass? Which would weigh more? Why?*

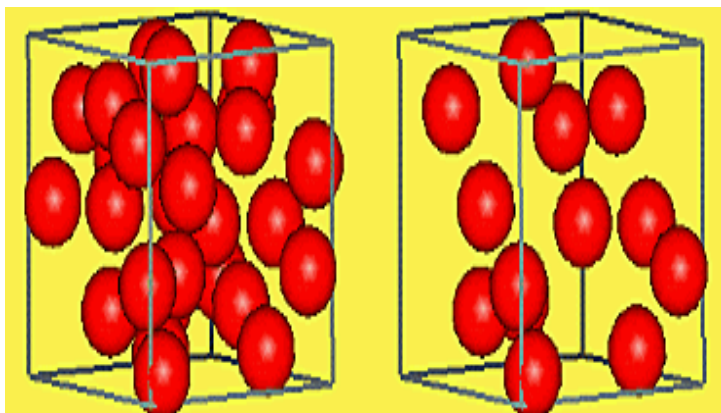

$$\text{Density} = \frac{\text{mass}}{\text{volume}}$$

The box that has more balls has more mass per unit of volume. This property of matter is called density. The density of a material helps to distinguish it from other materials. Since mass is usually expressed in grams and volume in cubic centimeters, density is expressed in grams/cubic centimeter

The formal definition of density is mass per unit volume. Usually the density is expressed in grams per mL or cc. Mathematically a "per" statement is translated as a division. cc is a cubic centimeter and is equal to a mL Therefore,

Periodic Table

The properties of the [elements](#) exhibit trends. These trends can be predicted using the [periodic table](#) and can be explained and understood by analyzing the [electron configurations](#) of the elements. Elements tend to gain or lose [valence electrons](#) to achieve stable octet (8) formation. Stable octets are seen in the inert gases, or noble gases, of Group VIII of the periodic table.

Chemical Compounds

A **chemical formula** is a combination of elemental symbols and subscript numbers that is used to show the composition of a compound. Depending of the type of compound that the formula represents, the information that it provides will vary slightly. Before we go about learning how to write chemical formulas, it is important that you clearly understand the difference between **covalent (molecular) compounds** and **ionic compounds**.

Ionic compounds are composed of charged ions that are held together by electrostatic forces. A typical type of ionic compound, called a **binary compound** because it is made up of **two elements**, will be composed of metallic positive ions (**cations**) and nonmetal negative ions (**anions**). When dealing with ionic formulas it is very important to remember that the formula does not show how the compound actually exists in nature. It only shows the ratio by which the individual ions combine. For example, the ionic formula for calcium chloride is CaCl_2 .

Covalent (molecular) compounds are held together by covalent bonds, or shared pairs of electrons. When we say that the molecular formula of water is H_2O , we can see that the molecules of water are made up of three atoms, two hydrogen atoms are covalently bonded to each oxygen atom.

You will be given the name of a binary compound and you will be expected to be able to write the proper formula for the compound. There will be two sources of information for writing the correct formula. The compounds name will give you the elements that make up the compound. The oxidation numbers of the ions involved will show you the ratio by which they combine. Let's go through an example;

Example 1. Write the correct formula for Barium Fluoride.

Step one - Write the symbols for the elements in the compound. If you need to review the elemental symbols, see [lesson 5-1](#). Note that the ending "ide" is used for fluoride to show that it is a negative ion of fluorine.



Step two - Look up the oxidation numbers of the elements involved (in table 5-2b or some similar table), and write them as superscripts to the right of the elemental symbols. Note that when no number accompanies a charge symbol, as in the case of fluoride below, they charge value is understood to be "1".

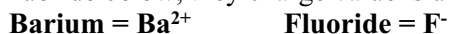

Step three - Use the correct combination of ions to produce a compound with a net charge of zero. In this case, $(2+) + 2(-1) = 0$. So, two fluoride ions will cancel out one barium ion. Since it would take two fluoride ions (each with a charge of negative one) to cancel out one barium ion (with a charge of plus two) we use a subscript of two after the symbol for fluorine to show the ratio.



If this seems confusing to you, it will get simpler over time.

For a binary compound containing two nonmetals, use the Greek prefixes before the names of the elements to determine the number of atoms of each in the compound. If there is no Greek prefix for the first element, there is just one atom of that element in the formula.

Greek Prefixes	Number
mono-	1
di-	2
tri-	3
tetra-	4
penta-	5
hexa-	6
hepta-	7
octa-	8
nona-	9
deca-	10

Chemical Equations: *SPS 2. Students will explore the nature of matter, its classifications, and its system for naming types of matter.*

SPS 2a. Calculate density when given a means to determine a substance's mass and volume.

SPS 2b. Predict formulas for stable binary ionic compounds based on balance of charges.

SPS 2c. Use IUPAC nomenclature for transition between chemical names and chemical formulas of binary ionic compounds (containing representative elements).

binary covalent compounds (i.e. carbon dioxide, carbon tetrachloride).

SPS 2d. Demonstrate the Law of Conservation of Matter in a chemical reaction.

SPS 2e. Apply the Law of Conservation of Matter by balancing the following types of chemical equations:

Synthesis

Decomposition

Single Replacement

Double Replacement

Chemical Equations

A chemical equation describes what happens in a chemical [reaction](#). The equation identifies the [reactants](#) (starting materials) and [products](#) (resulting substance), the formulas of the participants, the phases of the participants (solid, liquid, gas), and the amount of each substance. Balancing a chemical equation refers to establishing the mathematical relationship between the quantity of reactants and products. The quantities are expressed as grams or moles.

It takes practice to be able to write [balanced equations](#). There are essentially two steps to the process:

Step 1 - Write the unbalanced equation.

Chemical formulas of reactants are listed on the left hand side of the equation.

Products are listed on the right hand side of the equation.

Reactants and products are separated by putting an arrow between them to show the direction of the reaction.

Reactions at equilibrium will have arrows facing both directions.

Step 2 - Balance the equation.

Apply the [Law of Conservation of Mass](#) to get the same number of atoms of every element on each side of the equation. Tip: Start by balancing an element that appears in only *one* reactant and product.

Once one element is balanced, proceed to balance another, and another, until all elements are balanced.

Balance chemical formulas by placing coefficients in front of them. Do not add subscripts, because this will change the formulas.

Classifying Chemical Reactions: *SPS 2e. Apply the Law of Conservation of Matter by balancing the following types of chemical equations: Synthesis, Decomposition, Single Replacement, and Double Replacement.*

Chemists have identified millions of different compounds, so there must be millions of different chemical reactions to form them. When scientists are confronted with an overwhelming number of things, they tend to classify them into groups, in order to make them easier to study and understand. One popular classification scheme for chemical reactions breaks them up into five major categories or types. Some of these types have been given more than one name, so you need to learn them all. Even if your teacher prefers one name over another, you need to recognize each name, as you may encounter different names in different places.

Types of Chemical Reactions:

1. Synthesis (also called Direct Combination) - A synthesis reaction involves two or more substances combining to make a more complex substance. The reactants may be elements or compounds, and the product will always be a compound. The general formula for this type of reaction can be shown as;

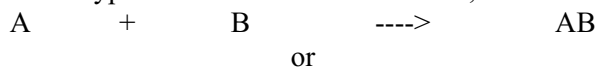

or

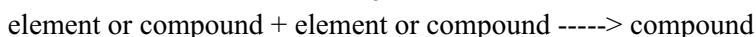

Some examples of synthesis reactions are shown below;

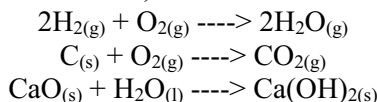

2. Decomposition (also called Analysis) - In a decomposition reaction, one substance is broken down into two or more, simpler substances. This type of reaction is the opposite of a synthesis reaction, as shown by the general formula below;

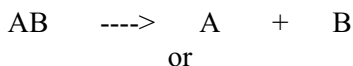

or



Some examples of decomposition reactions are shown below;

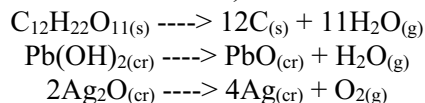

3. Single Displacement (also called Single Replacement) - In this type of reaction, a neutral element becomes an ion as it replaces another ion in a compound. The general form of this equation can be written as;

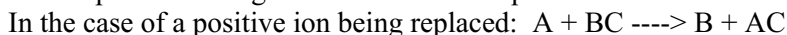

or

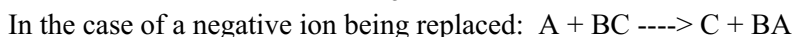

in either case we have;

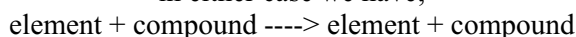

Some examples of single displacement reactions are shown below:

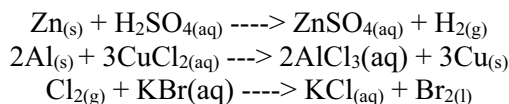

4. Double Displacement (also called Double Replacement) - Like dancing couples, the compounds in this type of reaction exchange partners. The basic form for this type of reaction is shown below;

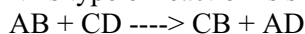

or

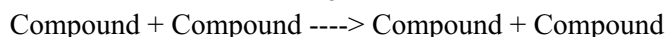

Some examples of double displacement reactions are shown below;

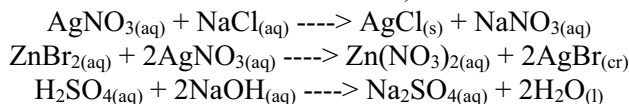

5. Combustion - When organic compounds like propane are burned, they react with the oxygen in the air to form carbon dioxide and water. The reason why these combustion reactions will stop when all available oxygen is used up is because oxygen is one of the reactants. The basic form of the combustion reaction is shown below;

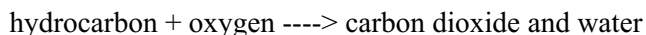

Some examples of combustion reactions are;

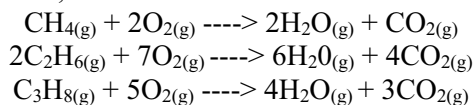

Solutions

SPS 6. Students will investigate the properties of solutions.

SPS 6a. Describe solutions in terms of

solute/solvent

conductivity

concentration

SPS 6b. Observe factors affecting the rate a solute dissolves in a specific solvent.

SPS 6c. Demonstrate that solubility is related to temperature by constructing a solubility curve.

Solutions

It is important to distinguish between three closely related terms solute, solvent, and solution.

Solute – The substance that dissolves to form a solution

Solvent – The substance in which a solute dissolves

Solution – A mixture of one or more solutes dissolved in a solvent

Properties of Solutions

A **solution** is a homogenous mixture of two or more substances that exist in a single phase. There are two main parts to any solution. The **solute** is the component of a solution that is dissolved in the solvent; it is usually present in a smaller amount than the solvent. The **solvent** is the component into which the solute is dissolved, and it is usually present in greater concentration. For example, in a solution of salt water, salt is the solute and water is the solvent. In solutions where water is the solvent, the solution is referred to as an *aqueous* solution.

A solution does not have to involve liquids. For instance, air is a solution that consists of nitrogen, oxygen, carbon dioxide, and other trace gases, and solder is a solution of lead and tin. The general rule of thumb for solutions is the idea that **like dissolves like**. **Polar**, ionic substances are soluble in polar solvents, while **nonpolar** solutes are soluble in nonpolar solvents. For example, alcohol and water, which are both polar, can form a solution and iodine and carbon tetrachloride, which are both nonpolar, make a solution. However, iodine will not readily dissolve in polar water.

Solubility charts (tables) and Graphs

Compound	0° C	20° C	60° C	100° C
Ammonium chloride	29.4	37.2	55.3	77.3
Copper(II) sulfate	23.1	32.0	61.8	114
Lead(II)chloride	0.67	1.0	1.94	3.2
Potassium bromide	53.6	65.3	85.5	104
Potassium chloride	28.0	34.0	45.8	56.3
Sodium acetate	36.2	46.4	139	170.15
Sodium chlorate	79.6	95.9	137	204

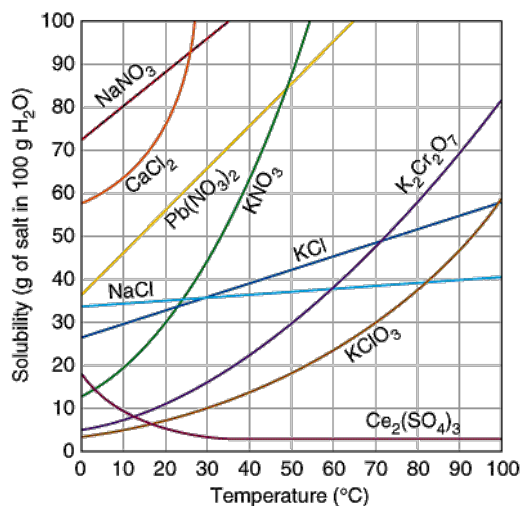

Acids and Bases

SPS 6d. Compare and contrast the components and properties of acids and bases.

SPS 6e. Determine whether common household substances are acidic, basic, or neutral.

I. Acids

*Acids are ionic compounds (a compound with a positive or negative charge) that break apart in water to form a hydrogen ion (H⁺).

*The strength of an acid is based on the concentration of H⁺ ions in the solution. **The more H⁺ the stronger the acid.**

Example: HCl (Hydrochloric acid) in water

Characteristics of Acids:

**Acids taste sour **Acids react strongly with metals (Zn + HCl)

**Strong Acids are dangerous and can burn your skin

Examples of Acids:

1. Vinegar
2. Citrus Fruits
3. Stomach Acid (HCl)

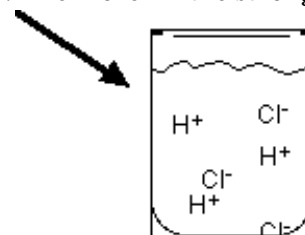

II. Bases

*Bases are ionic compounds that break apart to form a negatively charged hydroxide ion (OH⁻) in water.

*The strength of a base is determined by the concentration of Hydroxide ions (OH⁻). **The greater the concentration of OH⁻ ions the stronger the base.**

Example: NaOH (Sodium Hydroxide-a strong base) in water.

**Solutions containing bases are often called *alkaline*.

Characteristics of Bases:

**Bases taste bitter **Bases feel slippery

**Strong bases are very dangerous and can burn your skin

Examples:

1. Lye (Sodium Hydroxide)
2. Ammonia

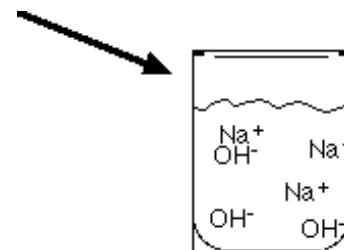

III. Neutralization Reactions

** When acids and bases are added to each other they react to neutralize each other if an equal number of hydrogen and hydroxide ions are present.

When this reaction occurs -salt and water are formed.



(Acid) (Base)---(Salt) (Water)

What are some useful applications of this reaction?

IV. pH Scale and Indicators

**The strength of an acid or base in a solution is measured on a scale called a pH scale.

**The pH scale is a measure of the hydrogen ion concentration. It spans from 0 to 14 with the middle point (pH 7) being neutral (neither acidic or basic).

Any pH number **greater than 7** is considered a **base** and any **pH number less than 7** is considered an **acid**. 0 is the strongest acid and 14 is the strongest base.

Indicators-- An indicator is a special type of compound that changes color as the pH of a solution changes, thus telling us the pH of the solution.

pH Scale

Acidic and basic are two extremes that describe a chemical property chemicals. Mixing acids and bases can cancel out or neutralize their extreme effects. A substance that is neither acidic nor basic is neutral.

The pH scale measures how acidic or basic a substance is. The pH scale ranges from 0 to 14. A pH of 7 is neutral. A pH less than 7 is acidic. A pH greater than 7 is basic.

Pure water is neutral. But when chemicals are mixed with water, the mixture can become either acidic or basic. Examples of acidic substances are vinegar and lemon juice. Lye, milk of magnesia, and ammonia are examples of basic substance,

