

G-W Goodheart-Willcox Publisher

Modern Automotive Technology

8th Edition



James E. Duffy

Presentations for PowerPoint

Modern Automotive Technology



The Goodheart-Willcox Co., Inc.
Tinley Park, Illinois

Chapter

1

The Automobile

Objectives

After studying this chapter, you will be able to:

- Identify and describe primary parts within major automotive systems.
- Explain the frequent electronic interaction of major automotive systems or circuits.
- Describe and compare major automobile design variations.

Objectives

- Identify and locate the most important systems used to operate conventional and hybrid passenger vehicles.
- Comprehend later textbook chapters with a minimum amount of difficulty.
- Correctly answer ASE certification test questions that require a general understanding of the major parts and systems of a vehicle.

The Automobile

- Automobile
 - Derived from Greek word *autos*, which means self, and French word *mobile*, which means moving
- Technology
 - Application of math, science, physics, engineering, and other subjects

Parts, Assemblies, and Systems

- Part or component
 - Smallest removable item on car
- Assembly
 - Set of fitted parts designed to complete specific function
- System
 - Group of related parts and assemblies that perform specific function

Major Vehicle Systems

- Body and frame
- Engine
- Computer systems
- Fuel system
- Electrical system
- Cooling and lubrication systems
- Exhaust and emission control systems
- Drive train systems
- Suspension, steering, and brake systems
- Accessory and safety systems

Major Vehicle Systems (Cont.)

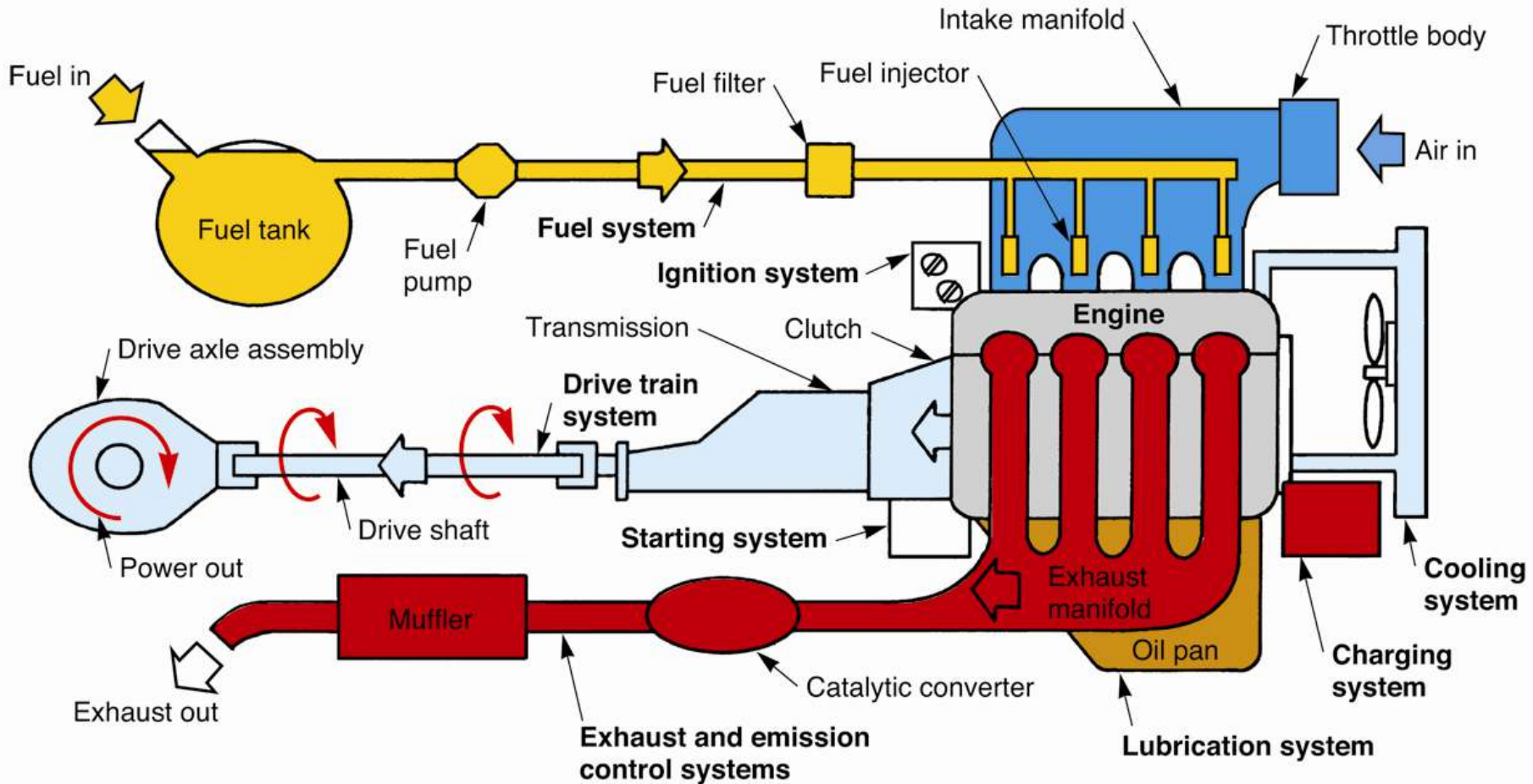

Frame, Body, and Chassis

- Frame
 - Metal structure, provides mounting place for all other parts
- Body
 - Skin forming outside of vehicle
- Chassis
 - Vehicle's frame and everything mounted to it
 - Exceptions

Frame, Body, and Chassis (Cont.)

- Body-over-frame construction (full-frame)
 - Used on vans, pickup trucks, and SUVs
- Unibody construction
 - Also called unit-body or unitized construction
 - Used on passenger cars (most common design)

Unibody with Chassis Removed

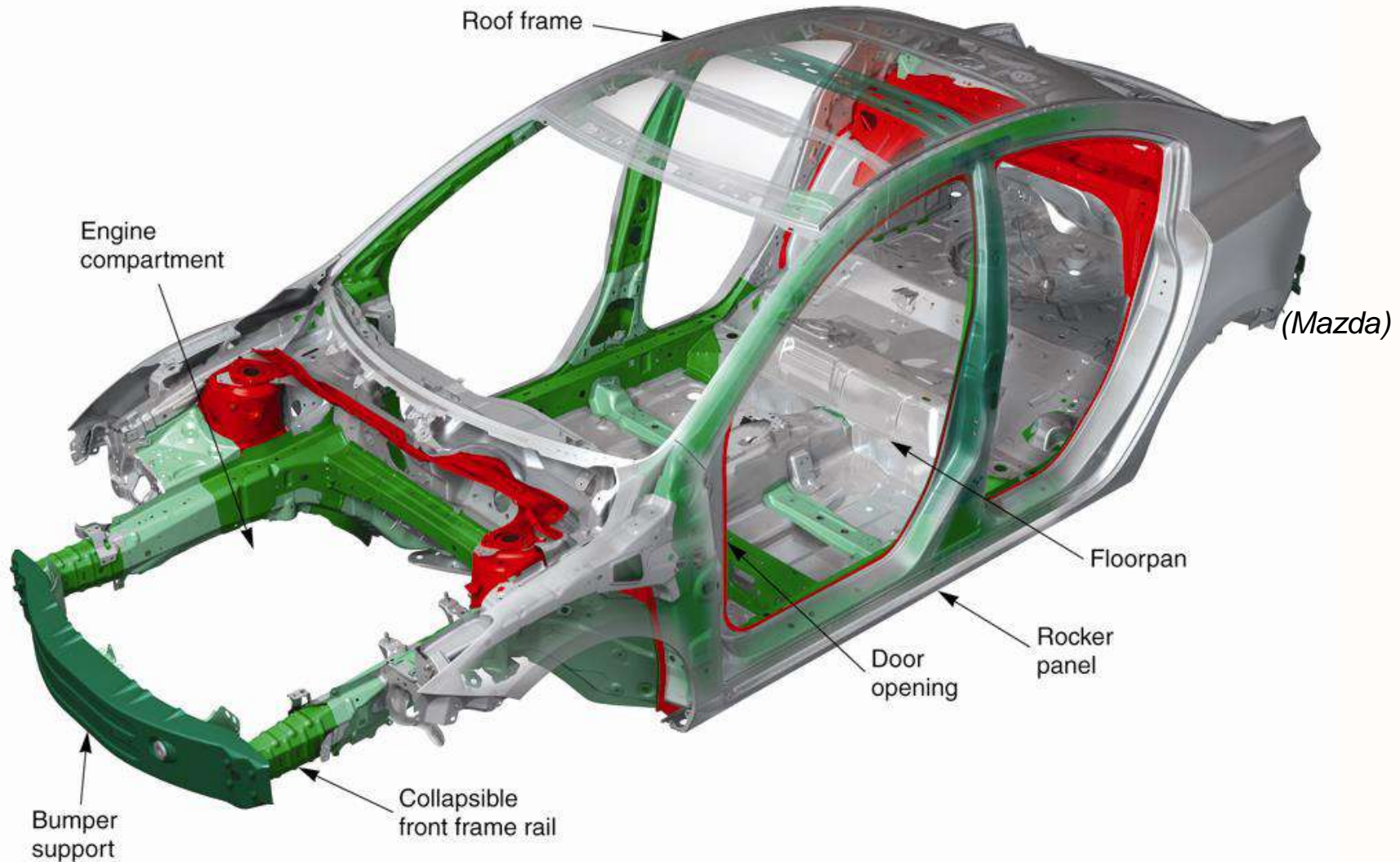

Unibody Chassis

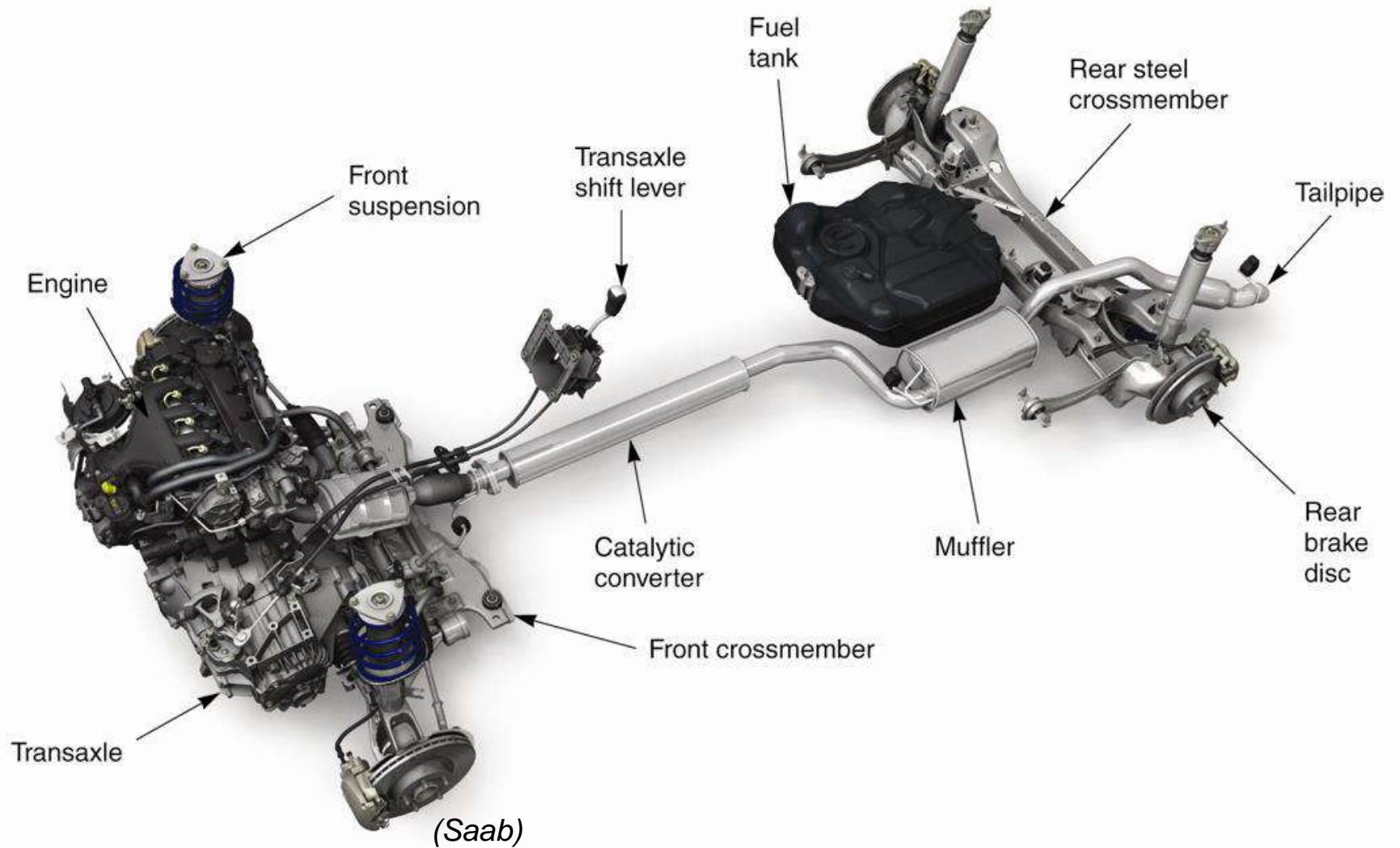

General Vehicle Specifications

- Vehicle curb weight
 - Total weight with full fuel tank and no driver
- Vehicle weight distribution
 - Downward force on front and rear tires
- Vehicle wheelbase
 - Distance between centerlines of front and rear wheels
- Track width
 - Distance between centerlines of two wheels on same axle

General Vehicle Specifications (Cont.)

- Vehicle length
 - Distance between outermost point of front bumper and outermost point of rear bumper
- Vehicle width
 - Widest points from right to left sides of body perpendicular to vehicle's centerline
- Vehicle height
 - Distance from ground to highest point of roofline

Vehicle Sizes

- Full-size
- Midsize
- Compact
- Mini-compact



nano

Vehicle Aerodynamics

- Aerodynamics
 - Study of the motion of air as it interacts with moving object
- Coefficient of drag (C_d)
 - Number that represents force required to move passenger vehicle through air

Vehicle Body Types



Sedan



Convertible



Hatchback



Station Wagon



Minivan



Sport-Utility Vehicle

(Porsche, Honda, Audi, Subaru)

Fuel Efficiency

- Rating of how far vehicle can travel on only one gallon of fuel
 - Gasoline, diesel oil, or stored electrical energy
- Testing and rates
 - EPA
- Also referred to as fuel economy

Basic Engine Parts

- Block
- Cylinder
- Piston
- Rings
- Connecting rod
- Crankshaft
- Cylinder head
- Combustion chamber
- Valves
- Camshaft
- Valve springs
- Rocker arms
- Lifter
- Flywheel

Basic Engine Parts (Cont.)

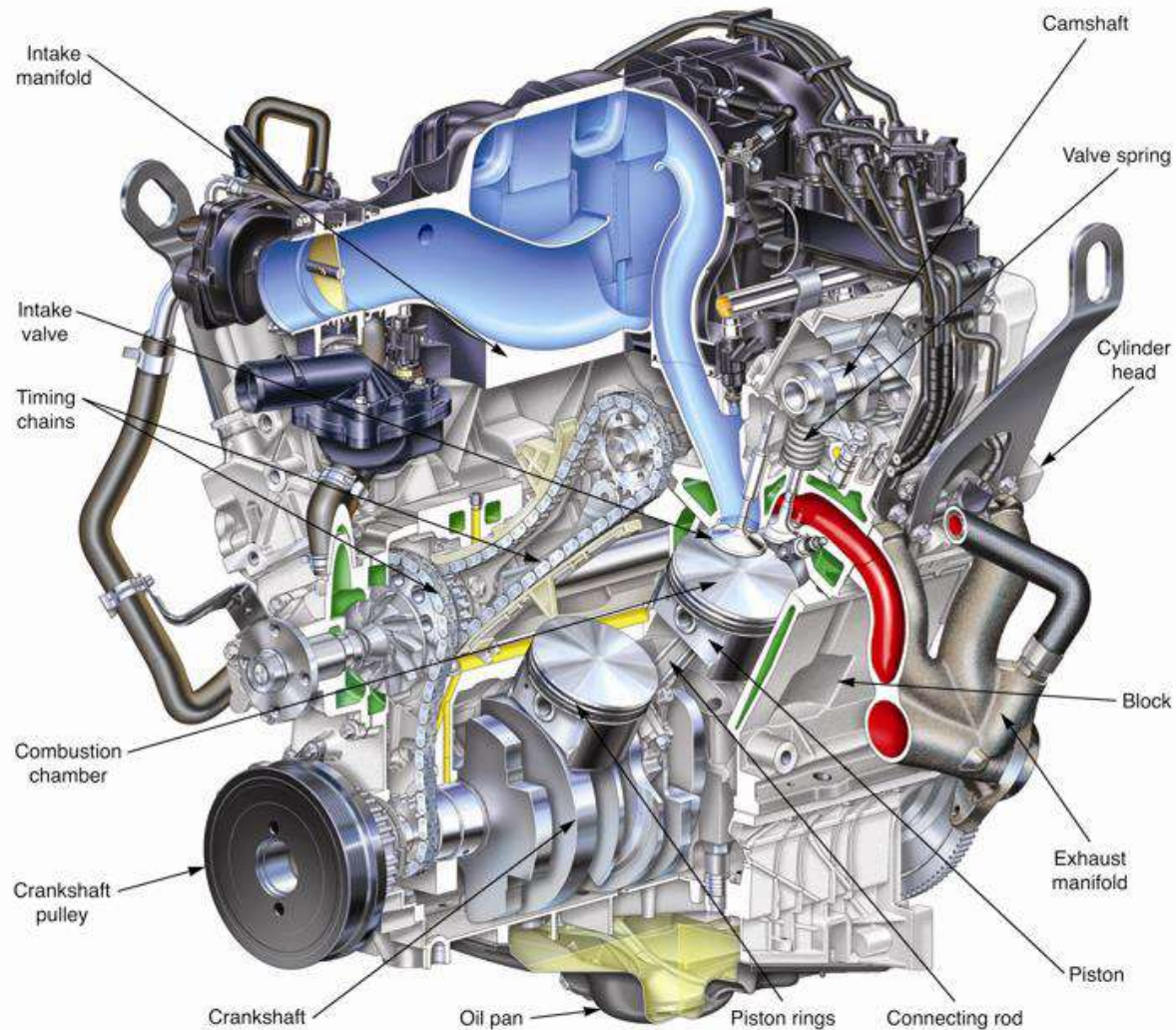

(Ford)

Automotive Internal Combustion Engines

- Normally use four-stroke cycle
 - Four piston strokes equals one cycle
- Multi-cylinder engines
 - 2-, 3-, 4-, 6-, 8-, 10-, or 12-cylinders

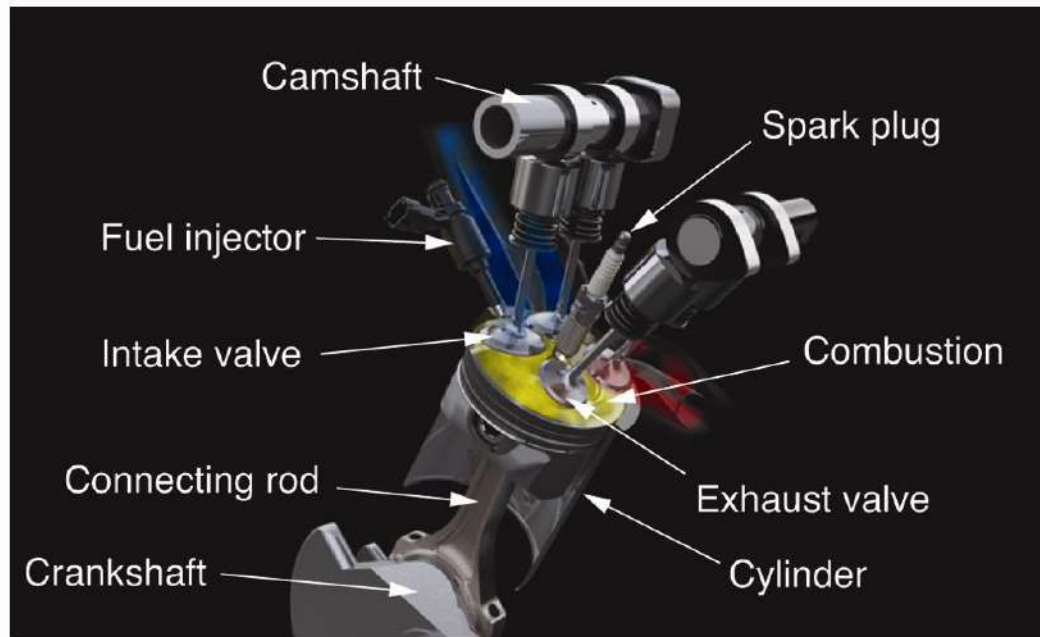

Computer System

- Sensors
- Electronic control module
- Actuators

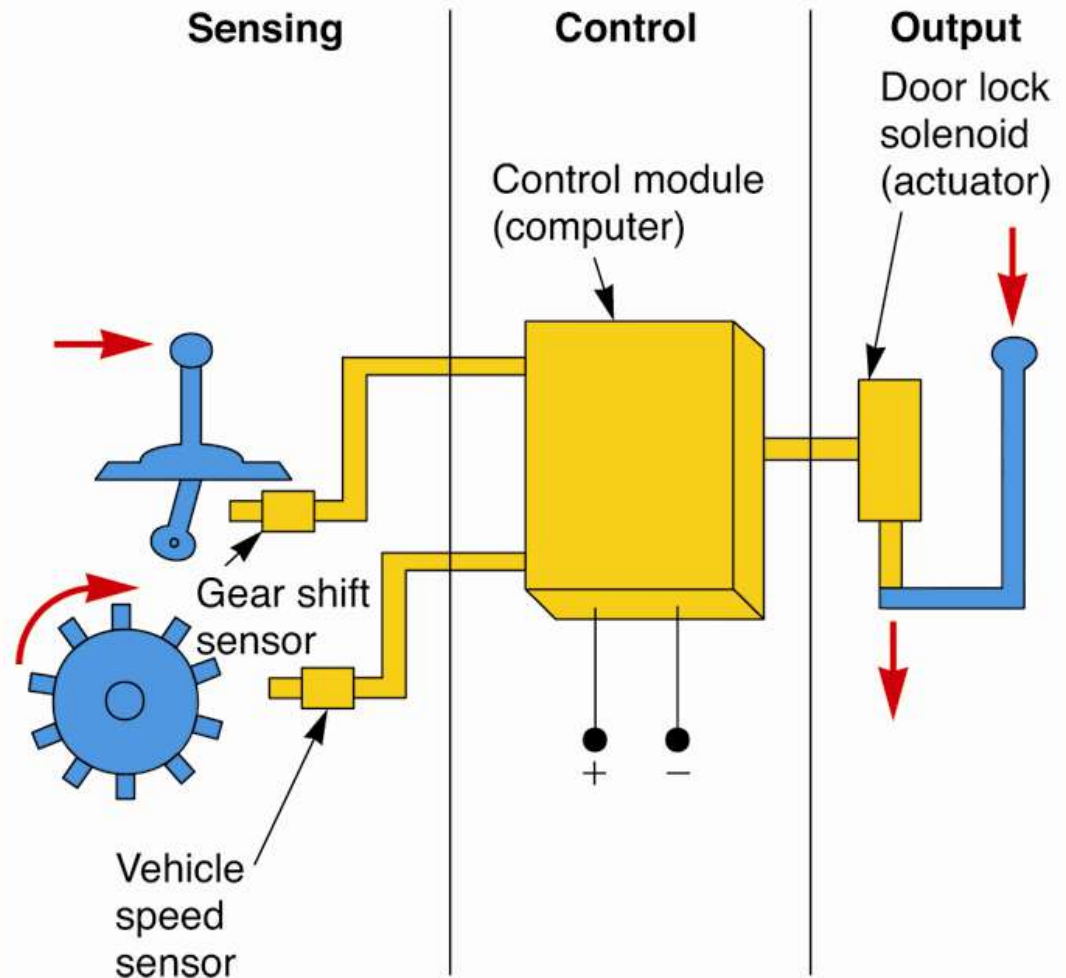

Fuel System

- Introduces correct amount of fuel into system for efficient combustion
- Air-fuel ratio
 - Percentage of air to fuel
- Gasoline injection systems
 - Uses engine control module, sensors, and fuel injectors to electrically meter fuel

Electrical System

- Ignition system
 - High voltage surge ignites air-fuel mixture
- Starting system
 - Electric motor that rotates crankshaft until engine can run on its own power
 - Requires battery power

Electrical System (Cont.)

- Charging system
 - Replaces electrical energy drawn from battery
- Lighting system
 - Interior and exterior lights with associated components
 - Fuses
 - Wires
 - Switches
 - Relays

Cooling and Lubrication Systems

- Cooling system
 - Maintains constant engine operating temperature
- Lubrication system
 - Reduces friction and wear between internal engine parts

Exhaust and Emission Control Systems

- Exhaust system
 - Quiets noise produced by engine operation
 - Routes exhaust gases to rear of vehicle
- Emission control system
 - Reduces amount of toxic substances produced by engine and fuel system

Drive Train Systems

- Transfers turning force from crankshaft to drive wheels
- Most common drive train configurations
 - Front-wheel drive
 - Rear-wheel drive
 - All-wheel drive

Drive Train Designs

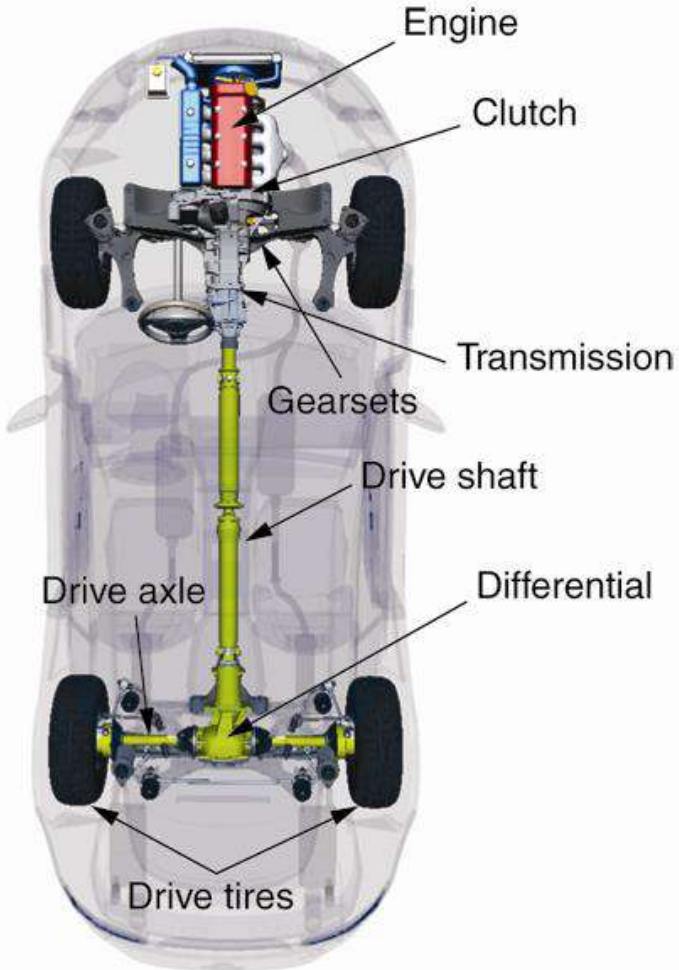

Front-Engine, Rear-Wheel Drive

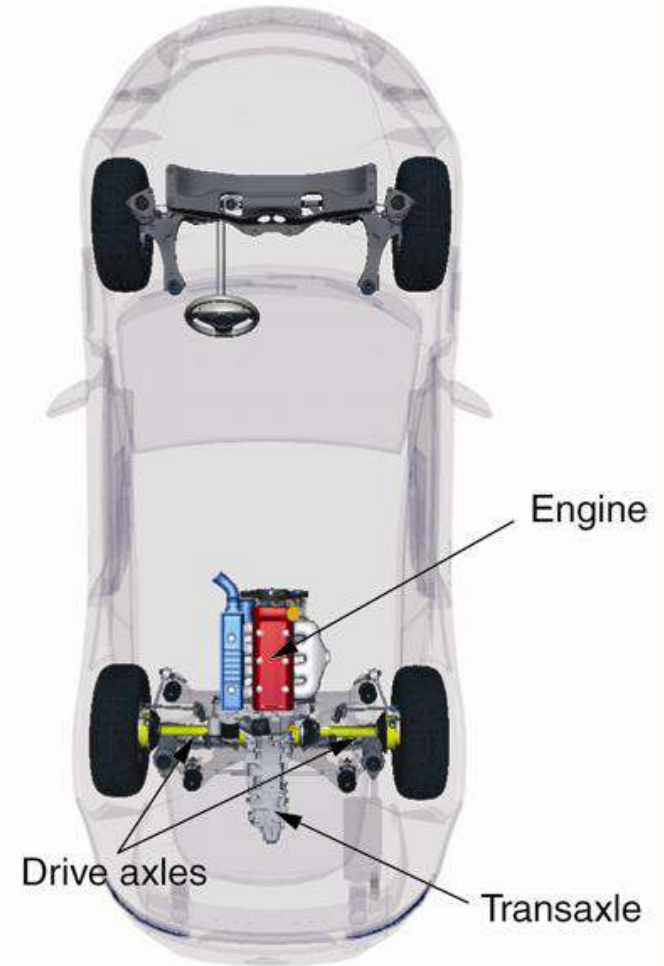

Mid-Engine, Rear-Wheel Drive

Drive Train Designs (Cont.)

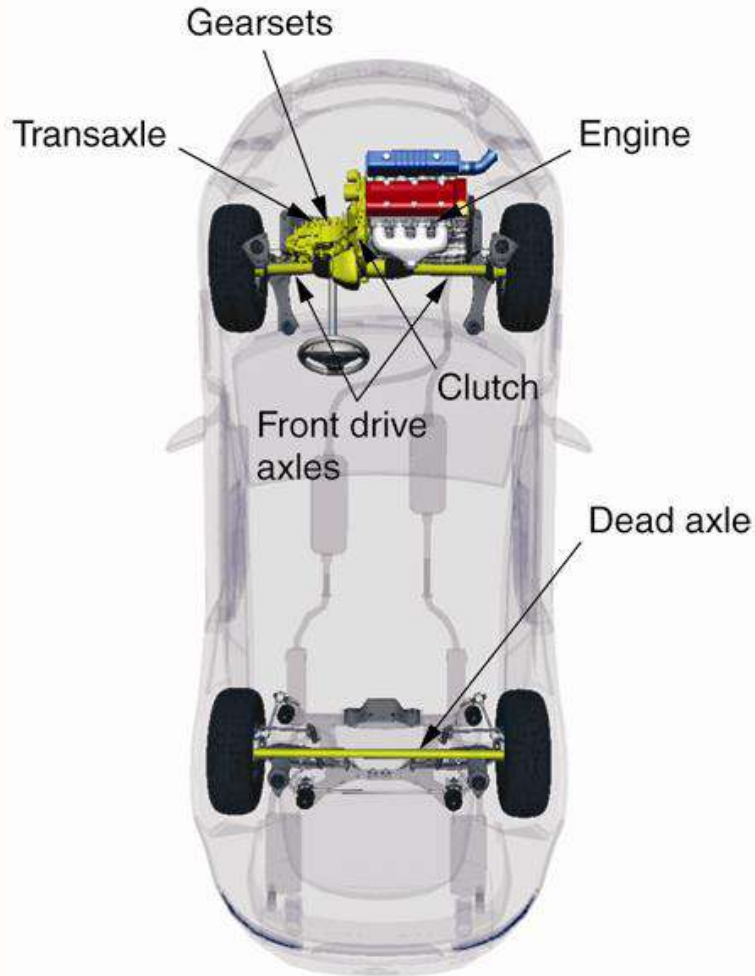

Front-Engine, Front-Wheel Drive

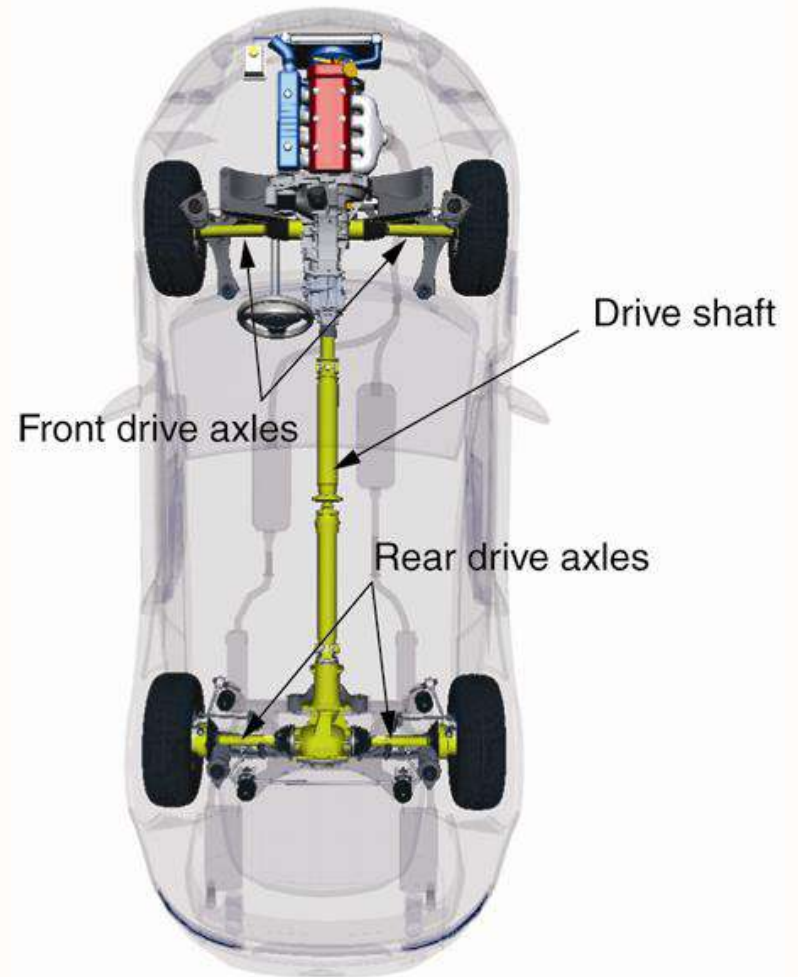

All-Wheel Drive

Drive Train Parts

- Clutch
- Transmission
 - Manual
 - Semi-automatic
 - Automatic
- Driveshaft
- Rear axle assembly
- Transaxle
- Front drive axles

Drive Train Parts (Cont.)

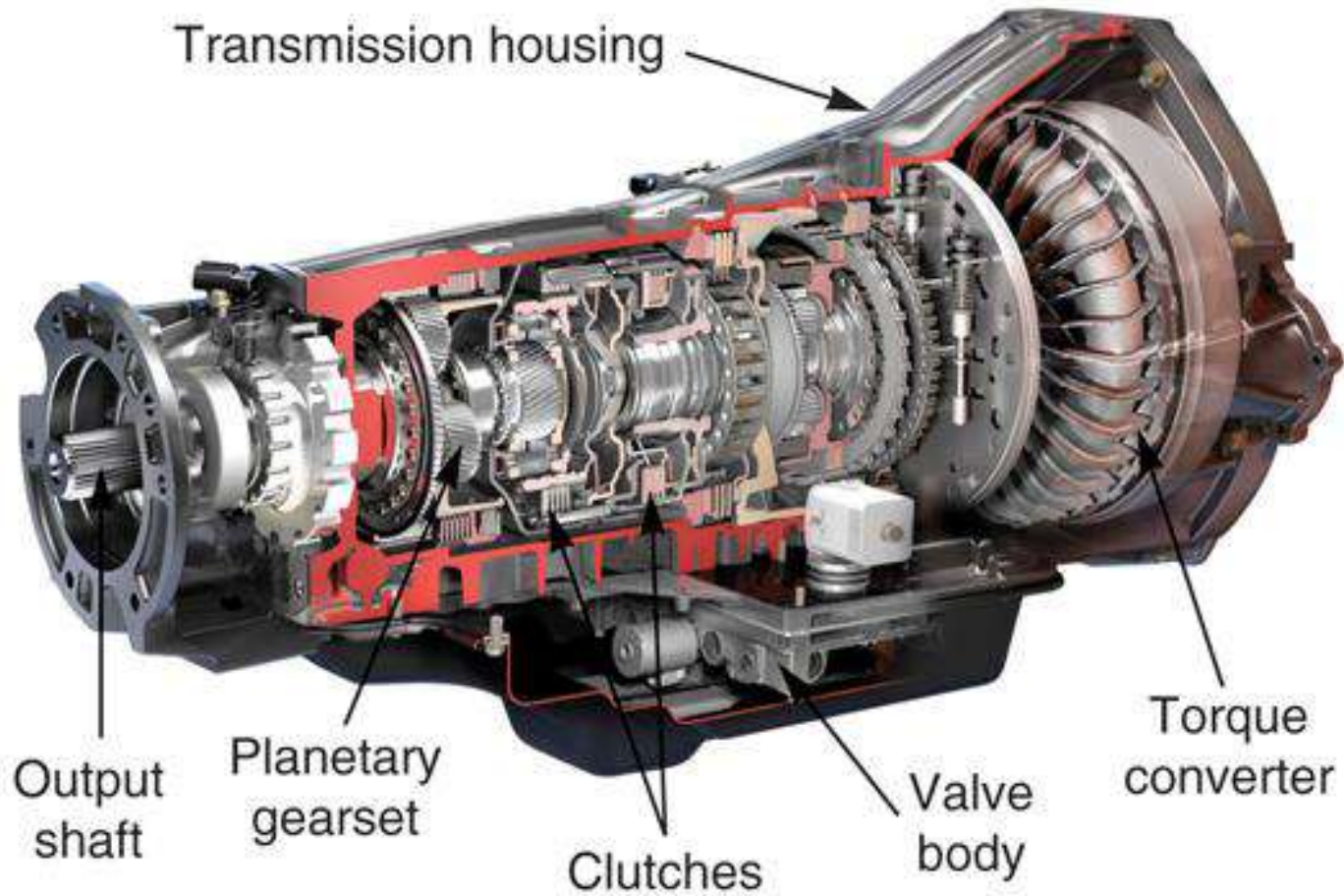

Automatic Transmission

(Ford)

Drive Train Parts (Cont.)

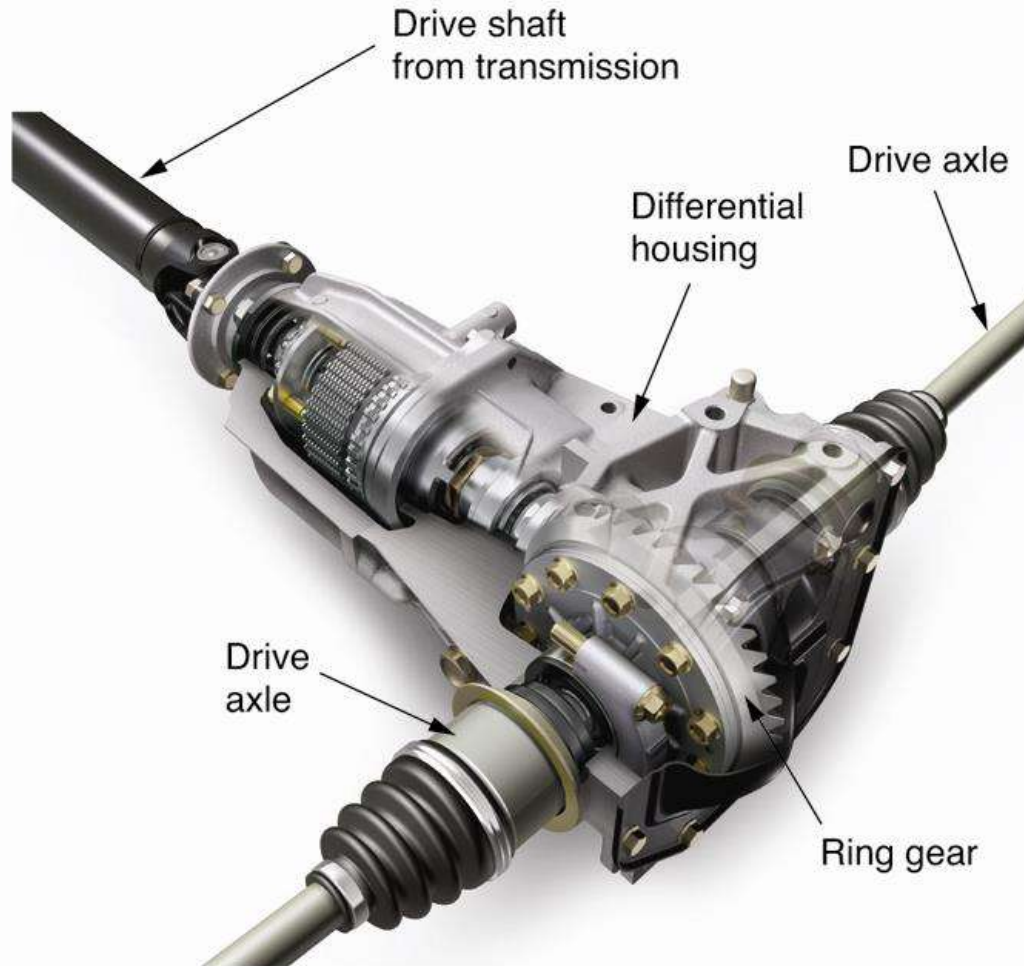

Rear Axle Assembly

(Mazda)

Suspension, Steering, and Brake Systems

- Suspension system
 - Allows wheels and tires to move up and down with little effect on body movement
- Steering system
 - Allows driver to turn wheels left or right
- Brake system
 - Produces friction to slow or stop the vehicle

Suspension, Steering, and Brake Systems (Cont.)

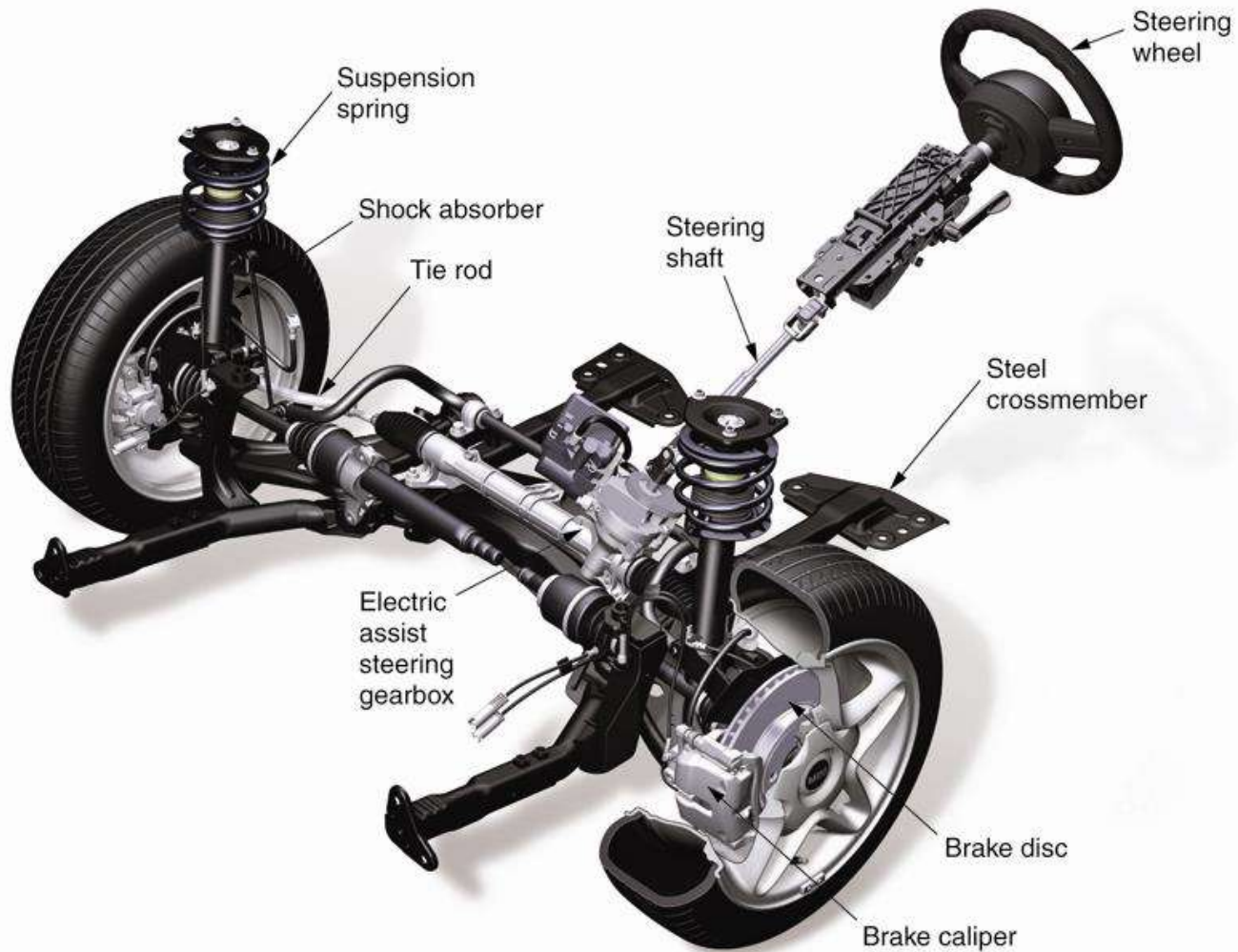

Front Steering and Suspension

(Mini Cooper)

Suspension, Steering, and Brake Systems (Cont.)

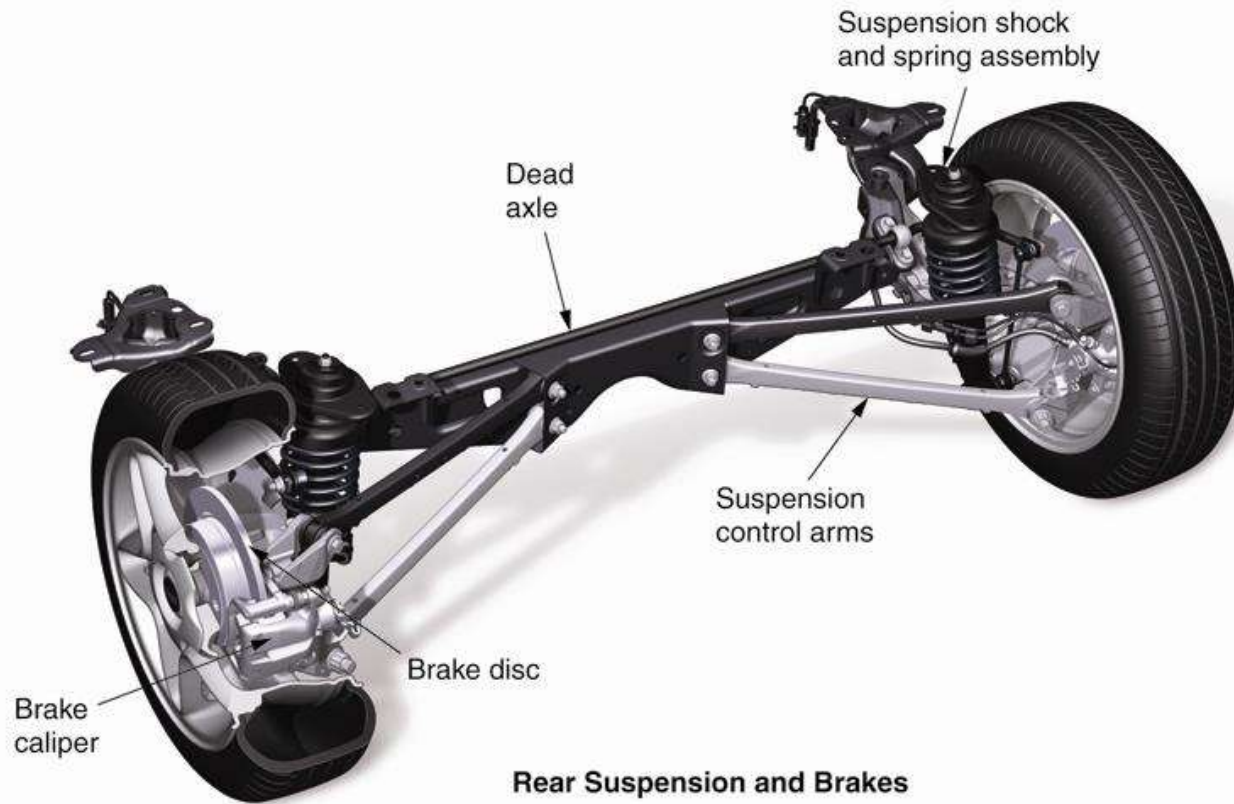

(Mini Cooper)

Accessory and Safety Systems

- Accessory systems
 - Air conditioner
 - Sound system
 - Power seats
 - Power windows
 - Rear defogger
- Safety systems
 - Seat belts
 - Air bags
 - Security system

Hybrid Vehicles

- Hybrid electric vehicle (HEV)
 - Combines two methods of propulsion
 - Internal combustion engine
 - Electric drive train
- Hybrid drive train parts
 - Motor generator
 - High-voltage (HV) power cables
 - HV battery
 - HV power control module
 - All hybrids use regenerative braking