



# Georgia Standards of Excellence Frameworks

## Mathematics

GSE First Grade

Unit 3: Operations and Algebraic Thinking



Richard Woods, Georgia's School Superintendent  
"Educating Georgia's Future"

*These materials are for nonprofit educational purposes only. Any other use may constitute copyright infringement.*

*The contents of this guide were developed under a grant from the U. S. Department of Education. However, those contents do not necessarily represent the policy of the U. S. Department of Education, and you should not assume endorsement by the Federal Government.*

**Georgia Department of Education**  
Georgia Standards of Excellence Framework  
*GSE Operations and Algebraic Thinking • Unit 3*

## Unit Three: Operations and Algebraic Thinking

### TABLE OF CONTENTS

Overview .....	3
Standards for Mathematical Practice .....	4
Standards for Mathematical Content .....	4
Big Ideas .....	5
Essential Questions .....	6
Concepts & Skills to Maintain .....	6
Strategies for Teaching and Learning .....	6
Selected Terms and Symbols .....	9
FAL .....	9
Sample Unit Assessments .....	9
Number Talks .....	9
Writing in Math .....	10
Page Citations .....	11
Tasks .....	12
1. <a href="#">Developing Meaning Using Story Problems: Result Unknown</a> .....	15
2. <a href="#">Lots of Dots</a> .....	22
3. <a href="#">What Numbers Can You Make</a> .....	29
4. <a href="#">Wheel Shop</a> .....	35
5. <a href="#">I Want Candy!</a> .....	44
6. <a href="#">Digging Dinosaurs</a> .....	53
7. <a href="#">Developing Meaning Using Story Problems: Change Unknown</a> .....	64
FAL .....	71
8. <a href="#">Shape Pounds</a> .....	72
9. <a href="#">Fact Families to Ten</a> .....	78
10. <a href="#">Developing Meaning Using Story Problems: Initial Unknown</a> .....	83
11. <a href="#">Domino Fact Family</a> .....	88
12. <a href="#">Candy</a> .....	94
13. <a href="#">Culminating Task : Atlanta Zoo</a> .....	97

\*\*\*Please note that all changes made to standards will appear in red bold type. Additional changes will appear in green.

## **OVERVIEW**

In this unit, students will:

- Explore, understand, and apply the commutative and associative properties as strategies for solving addition problems.
- Share, discuss, and compare strategies as a class.
- Connect counting on to solving subtraction problems. For the problem “ $15 - 7 = ?$ ” they think about the number they have to count on from 7 to get to 15.
- Work with sums and differences less than or equal to 20 using the numbers 0 to 20.
- Identify and then apply a pattern or structure in mathematics. For example, pose a string of addition and subtraction problems involving the same three numbers chosen from the numbers 0 to 20, such as  $4 + 13 = 17$  and  $13 + 4 = 17$ .
- Analyze number patterns and create conjectures or guesses.
- Choose other combinations of three numbers and explore to see if the patterns work for all numbers 0 to 20.
- Understand that addition and subtraction are related and that subtraction can be used to solve problems where the addend is unknown.
- Use the strategies of counting on and counting back to understand number relationships.
- Organize and record results using tallies and tables.
- Determine the initial and the change unknown.

Students develop strategies for adding and subtracting whole numbers based on their prior work with small numbers. They use a variety of models, including discrete objects and length-based models (e.g., cubes connected to form lengths), to model add-to, take-from, put-together, take-apart, and compare situations. They will use these models to develop meaning for the operations of addition and subtraction and to develop strategies to solve arithmetic problems with these operations. Prior to first grade students should recognize that any given group of objects (up to 10) can be separated into sub groups in multiple ways and remain equivalent in amount to the original group (Ex: A set of 6 cubes can be separated into a set of 2 cubes and a set of 4 cubes and remain 6 total cubes).

Students understand connections between counting and addition and subtraction (e.g., adding two is the same as counting on two). They use properties of addition to add whole numbers and to create and use increasingly sophisticated strategies based on these properties (e.g., —making tens) to solve addition and subtraction problems within 20. By comparing a variety of solution strategies, children build their understanding of the relationship between addition and subtraction. (Ohio DOE)

The standard MGSE1.OA.3 expects teachers to use their understanding of the commutative and associative properties when teaching addition. The students are NOT expected to name or memorize these properties. First grade teachers are laying the foundation and building an understanding of these properties so that students can have formal discussions and utilize names of the properties in later grades.

## STANDARDS FOR MATHEMATICAL PRACTICE

The Standards for Mathematical Practice describe varieties of expertise that mathematics educators at all levels should seek to develop in their students. These practices rest on important “processes and proficiencies” with longstanding importance in mathematics education.

*Students are expected to:*

1. Make sense of problems and persevere in solving them.
2. Reason abstractly and quantitatively.
3. Construct viable arguments and critique the reasoning of others.
4. Model with mathematics.
5. Use appropriate tools strategically.
6. Attend to precision.
7. Look for and make use of structure.
8. Look for and express regularity in repeated reasoning.

**\*\*\*Mathematical Practices 1 and 6 should be evident in EVERY lesson\*\*\***

## STANDARDS FOR MATHEMATICAL CONTENT

**Represent and solve problems involving addition and subtraction.**

**MGSE1.OA.1.** Use addition and subtraction within 20 to solve word problems involving situations of adding to, taking from, putting together, taking apart, and comparing, with unknowns in all positions, e.g., by using objects, drawings, and equations with a symbol for the unknown number to represent the problem.<sup>1</sup>

**Understand and apply properties of operations and the relationship between addition and subtraction.**

**MGSE1.OA.3.** Apply properties of operations as strategies to add and subtract.<sup>2</sup>

Examples: If  $8 + 3 = 11$  is known, then  $3 + 8 = 11$  is also known. (Commutative property of addition.) To add  $2 + 6 + 4$ , the second two numbers can be added to make a ten, so  $2 + 6 + 4 = 2 + 10 = 12$ . (Associative property of addition.)

**MGSE1.OA.4.** Understand subtraction as an unknown-addend problem. For example, subtract  $10 - 8$  by finding the number that makes 10 when added to 8.

**Add and subtract within 20**

**MGSE1.OA.5.** Relate counting to addition and subtraction (e.g., by counting on 2 to add 2).

---

<sup>1</sup> See Glossary, Table 1

<sup>2</sup> Students need not use formal terms for these properties. Problems should be within 20.

**MGSE1.OA.6 Add and subtract within 20.**

- a. Use strategies such as counting on; making ten (e.g.,  $8 + 6 = 8 + 2 + 4 = 10 + 4 = 14$ ); decomposing a number leading to a ten (e.g.,  $13 - 4 = 13 - 3 - 1 = 10 - 1 = 9$ ); using the relationship between addition and subtraction (e.g., knowing that  $8 + 4 = 12$ , one knows  $12 - 8 = 4$ ); and creating equivalent but easier or known sums (e.g., adding  $6 + 7$  by creating the known equivalent  $6 + 6 + 1 = 12 + 1 = 13$ ).**
- b. Fluently add and subtract within 10.**

**Work with addition and subtraction equations**

**MGSE1.OA.7** Understand the meaning of the equal sign, and determine if equations involving addition and subtraction are true or false. For example, which of the following equations are true and which are false?  $6 = 6$ ,  $7 = 8 - 1$ ,  $5 + 2 = 2 + 5$ ,  $4 + 1 = 5 + 2$ .

The equal sign describes a special relationship between two quantities. In the case of a true equation, the quantities are the same.

**MGSE1.OA.8** Determine the unknown whole number in an addition or subtraction equation relating to three whole numbers. For example, determine the unknown number that makes the equation true in each of the equations  $8 + ? = 11$ ,  $5 = \square - 3$ ,  $6 + 6 = \Delta$ .

**Represent and interpret data.**

**MGSE1.MD.4.** Organize, represent, and interpret data with up to three categories; ask and answer questions about the total number of data points, how many in each category, and how many more or less are in one category than in another.

**Big Ideas**

- Students develop strategies for adding and subtracting whole numbers based on their prior work with small numbers.
- Students use a variety of models, including discrete objects and length-based models (e.g., cubes connected to form lengths), to model add-to, take-from, put-together, take-apart, and compare situations. They will use these models to develop meaning for the operations of addition and subtraction, and to develop strategies to solve arithmetic problems with these operations.
- Students understand connections between counting and addition/subtraction (e.g., adding two is the same as counting on two).
- Students use properties of addition to add whole numbers and to create and use increasingly sophisticated strategies based on these properties (e.g., “making tens”) to solve addition and subtraction problems within 20.
- By comparing a variety of solution strategies, students will build an understanding of the relationship between addition and subtraction.

**Georgia Department of Education**  
Georgia Standards of Excellence Framework  
*GSE Operations and Algebraic Thinking • Unit 3*

- Students think of whole numbers between 10 and 100 in terms of tens and ones (especially recognizing the numbers 11 to 19 as composed of a ten and some ones).

**ESSENTIAL QUESTIONS**

- How can we represent a set of objects using numerals?
- What happens when we join two quantities or take one from another?
- How can we find the total when we join two quantities?
- How can we find what is left when we take one quantity from another?
- How can we find the difference when we compare one quantity to another?
- How can we represent problem situations?
- What happens when we change the order of numbers when we add (or subtract)? Why?
- How can we show that addition and subtraction are related through fact families?
- How can we use different combinations of numbers and operations to represent the same quantity?
- How can we represent a number in a variety of ways?

**CONCEPTS AND SKILLS TO MAINTAIN**

- Represent addition and subtraction with objects, fingers, mental images, and drawings
- Solve addition and subtraction word problems
- Add and subtract within 10
- Decompose numbers that are less than or equal to 10 in more than one way
- Make a ten from any given number 1-9
- Fluently add and subtract within 5

**STRATEGIES FOR TEACHING AND LEARNING**

**Addition and Subtraction in Elementary School**

- The strategies that students use to solve problems provide important information concerning number sense, and place value.
- It is important to look at more than the answers students get. The strategies used provide useful information about what problems to give the next day and how to differentiate instruction.
- It is important to relate addition and subtraction.
- Student created strategies provide reinforcement of place value concepts. Traditional algorithms can actually confuse the understanding of place value.
- Student created strategies are built on a student's actual understanding, instead of on what the book says or what we think/hope they know!
- Students make fewer errors with invented strategies, because they are built on understanding rather than memorization.

**Georgia Department of Education**  
 Georgia Standards of Excellence Framework  
*GSE Operations and Algebraic Thinking • Unit 3*

Students use various counting strategies, including **counting all, counting on, and counting back** with numbers up to 20. This standard calls for students to move beyond counting all and become comfortable at counting on and counting back. The counting all strategy requires students to count an entire set. The counting and counting back strategies occur when students are able to hold the start number in their head and count on from that number

**Table 1: Common addition and subtraction situations**

	Result Unknown	Change Unknown	Start Unknown
Add to	Two bunnies sat on the grass. Three more bunnies hopped there. How many bunnies are on the grass now? $2 + 3 = ?$	Two bunnies were sitting on the grass. Some more bunnies hopped there. Then there were five bunnies. How many bunnies hopped over to the first two? $2 + ? = 5$	Some bunnies were sitting on the grass. Three more bunnies hopped there. Then there were five bunnies. How many bunnies were on the grass before? $? + 3 = 5$
Take from	Five apples were on the table. I ate two apples. How many apples are on the table now? $5 - 2 = ?$	Five apples were on the table. I ate some apples. Then there were three apples. How many apples did I eat? $5 - ? = 3$	Some apples were on the table. I ate two apples. Then there were three apples. How many apples were on the table before? $? - 2 = 3$

	Total Unknown	Addend Unknown	Both Addends Unknown
Put Together	Three red apples and two green apples are on the table. How many apples are on the table? $3 + 2 = ?$	Five apples are on the table. Three are red and the rest are green. How many apples are green? $3 + ? = 5, 5 - 3 = ?$	Grandma has five flowers. How many can she put in her red vase and how many in her blue vase? $5 = 0 + 5, 5 = 5 + 0$ $5 = 1 + 4, 5 = 4 + 1$ $5 = 2 + 3, 5 = 3 + 2$
Take Apart			

	Difference Unknown	Bigger Unknown	Smaller Unknown
Compare	(“How many more?” version): Lucy has two apples. Julie has five apples. How many more apples does Julie have than Lucy? (“How many fewer?” version): Lucy has two apples. Julie has five apples. How many fewer apples does Lucy have than Julie? $2 + ? = 5, 5 - 2 = ?$	(Version with “more”): Julie has three more apples than Lucy. Lucy has two apples. How many apples does Julie have? (Version with “fewer”): Lucy has 3 fewer apples than Julie. Lucy has two apples. How many apples does Julie have? $2 + 3 = ?, 3 + 2 = ?$	(Version with “more”): Julie has three more apples than Lucy. Julie has five apples. How many apples does Lucy have? (Version with “fewer”): Lucy has 3 fewer apples than Julie. Julie has five apples. How many apples does Lucy have? $5 - 3 = ?, ? + 3 = 5$



From the Common Core State Standards Glossary

**For more detailed information about unpacking the standards, unpacking a task, math routines and rituals, maintenance activities and more, please refer to the Grade Level Overview document.**

**Fluency:** Procedural fluency is defined as skill in carrying out procedures flexibly, accurately, efficiently, and appropriately. Fluent problem solving does not necessarily mean solving problems within a certain time limit, though there are reasonable limits on how long computation should take. Fluency is based on a deep understanding of quantity and number.

**Deep Understanding:** Teachers teach more than simply “how to get the answer” and instead support students’ ability to access concepts from a number of perspectives. Therefore students are able to see math as more than a set of mnemonics or discrete procedures. Students demonstrate deep conceptual understanding of foundational mathematics concepts by applying them to new situations, as well as writing and speaking about their understanding.

**Memorization:** The rapid recall of arithmetic facts or mathematical procedures. Memorization is often confused with fluency. Fluency implies a much richer kind of mathematical knowledge and experience.

**Number Sense:**

Students consider the context of a problem, look at the numbers in a problem, make a decision about which strategy would be most efficient in each particular problem. Number sense is not a deep understanding of a single strategy, but rather the ability to think flexibly between a variety of strategies in context.

**Fluent students:**

- flexibly use a combination of deep understanding, number sense, and memorization.
- are fluent in the necessary baseline functions in mathematics so that they are able to spend their thinking and processing time unpacking problems and making meaning from them.
- are able to articulate their reasoning.
- find solutions through a number of different paths.

For more about fluency, see:

<http://www.youcubed.org/wp-content/uploads/2015/03/FluencyWithoutFear-2015.pdf>

and:

<http://joboaler.com/timed-tests-and-the-development-of-math-anxiety/>

## **SELECTED TERMS AND SYMBOLS**

The following terms and symbols are often misunderstood. This is not an inclusive list and items should not be taught in isolation. However, due to evidence of frequent difficulty and misunderstanding associated with these concepts, instructors should pay particular attention to them and how their students are able to explain and apply them.

The terms below are **for teacher reference only and are not to be memorized by the students**. Teachers should present these concepts to students with models and real life examples. Students should understand the concepts involved and be able to recognize and/or demonstrate them with words, models, pictures, or numbers.

- addition and subtraction within 5, 10, 20, 100, or 1000.
- additive identity property of 0
- associative property of addition
- commutative property
- computation strategy
- counting on
- number line diagram
- strategies for addition

<http://www.corestandards.org/Math/Content/mathematics-glossary/glossary>

## **FAL**

The linked Formative Assessment lesson is designed to be part of an instructional unit. This assessment should be implemented approximately two-thirds of the way through this instructional unit and is noted in the unit task table. This assessment can be used at the beginning of the unit to ascertain student needs. The results of this task should give you pertinent information regarding your students learning and help to drive your instruction for the remainder of the unit.

## **SAMPLE UNIT ASSESSMENTS**

Math Unit Summative Assessments were written by the First Grade Mathematics Assessment and Curriculum Team, Jackson County, Georgia. The team is comprised of first grade teachers and administrators whose focus is to provide assessments that address depth of knowledge and higher order thinking skills. These assessments are provided as a courtesy from the Jackson County School System as samples that may be used as is or as a guide to create common assessments.

## **NUMBER TALKS**

In order to be mathematically proficient, today’s students must be able to compute accurately, efficiently, and flexibly. Daily classroom number talks provide a powerful avenue for developing “efficient, flexible, and accurate computation strategies that build upon the key foundational ideas of mathematics.” (Parrish, 2010) Number talks involve classroom conversations and discussions centered upon purposefully planned computation problems.

In Sherry Parrish’s book, Number Talks: Helping Children Build Mental Math and Computation Strategies, teachers will find a wealth of information about Number Talks, including:

- Key components of Number Talks
- Establishing procedures
- Setting expectations
- Designing purposeful Number Talks
- Developing specific strategies through Number Talks

There are four overarching goals upon which K-2 teachers should focus during Number Talks. These goals are:

1. Developing number sense
2. Developing fluency with small numbers
3. Subitizing
4. Making Tens

Suggested Number Talks for Unit 5 are addition: counting all and counting on; doubles/near doubles; and making tens using dot images, ten-frames, Rekenreks, double ten-frames, and number sentences. In addition, Number Talks focusing on making landmark or friendly numbers; breaking each number into its place value; compensation; and adding up chunks are suggested. Specifics on these Number Talks can be found on pages 98-201 of Number Talks: Helping Children Build Mental Math and Computation Strategies.

## **WRITING IN MATH**

The Standards for Mathematical Practice, which are integrated throughout effective mathematics content instruction, require students to explain their thinking when making sense of a problem (SMP 1). Additionally, students are required to construct viable arguments and critique the reasoning of others (SMP 2). Therefore, the ability to express their thinking and record their strategies in written form is critical for today’s learners. According to Marilyn Burns, “Writing in math class supports learning because it requires students to organize, clarify, and reflect on their ideas--all useful processes for making sense of mathematics. In addition, when students write, their papers provide a window into their understandings, their misconceptions, and their feelings about the content.” (Writing in Math. Educational Leadership. Oct. 2004 (30).) The use of math journals is an effective means for integrating writing into the math curriculum.

**Georgia Department of Education**  
Georgia Standards of Excellence Framework  
*GSE Operations and Algebraic Thinking • Unit 3*

Math journals can be used for a variety of purposes. Recording problem solving strategies and solutions, reflecting upon learning, and explaining and justifying thinking are all uses for math journals. Additionally, math journals can provide a chronological record of student math thinking throughout the year, as well as a means for assessment that can inform future instruction.

The following website provides a wealth of information and grade specific activities for math journaling: <http://www.k-5mathteachingresources.com/math-journals.html>. Though this is not a free site, there are some free resources that are accessible.

### **PAGE CITATIONS**

Teaching Student-Centered Mathematics written by Van de Walle, Lovin, Karp, and Bay-Williams, has been recently revised. Page citation numbers may vary due to this change.

### **TASK DESCRIPTIONS**

<b>Scaffolding Task</b>	Tasks that build up to the learning task.
<b>Constructing Task</b>	Constructing understanding through deep/rich contextualized problem solving tasks.
<b>Practice Task</b>	Tasks that provide students opportunities to practice skills and concepts.
<b>Culminating Task</b>	Designed to require students to use several concepts learned during the unit to answer a new or unique situation. Allows students to give evidence of their own understanding toward the mastery of the standard and requires them to extend their chain of mathematical reasoning.
<b>Formative Assessment Lesson (FAL)</b>	Lessons that support teachers in formative assessment which both reveal and develop students' understanding of key mathematical ideas and applications. These lessons enable teachers and students to monitor in more detail their progress towards the targets of the standards.
<b>3-Act Task</b>	A Three-Act Task is a whole-group mathematics task consisting of 3 distinct parts: an engaging and perplexing Act One, an information and solution seeking Act Two, and a solution discussion and solution revealing Act Three. More information along with guidelines for 3-Act Tasks may be found in the <i>Guide to Three-Act Tasks</i> on <a href="http://georgiastandards.org">georgiastandards.org</a> and the K-5 CCGPS Mathematics Wiki.

**Georgia Department of Education**  
 Georgia Standards of Excellence Framework  
*GSE Operations and Algebraic Thinking • Unit 3*

<b>Task Name</b>	<b>Task Type</b>	<b>Content Standard</b>	<b>Content Addressed</b>	<b>Brief Description</b>
<a href="#"><u>Task 1: Developing Meaning Using Story Problems: Result Unknown</u></a>	Constructing Task <i>Whole Group, Small Group, Individual</i>	MGSE1.OA.1	Problem solving with the result unknown	Students will solve real world math problems using addition and subtraction.
<a href="#"><u>Task 2: Lots of Dots</u></a>	Scaffolding Task <i>Small Group/ Partners/ Individual</i>	MGSE1.OA.3 MGSE1.OA.4 MCC.1OA.5 MGSE1.OA.6	Composing and decomposing of numbers	Students will practice finding sums, creating equations, expressions, and the commutative property.
<a href="#"><u>Task 3: What Numbers Can You Make?</u></a>	Constructing Task <i>Small Group/ Partners/ Individual</i>	MGSE1.OA.3 MGSE1.OA.4 MGSE.1.OA.5 MGSE1.OA.6 MGSE1.MD.4	Composing and Decomposing of numbers	Students will practice finding number combinations with like sums.
<a href="#"><u>Task 4: Wheel Shop</u></a>	Performance Task <i>Small Group/ Partners/ Individual</i>	MGSE1.OA.2 MGSE.1.OA.5	Problem solving	Students will find combinations of numbers for a given sum.
<a href="#"><u>Task 5: I Want Candy!</u></a>	3 Act Task <i>Large Group, Individual</i>	MGSE1.OA.1 MGSE.1.OA.5 MGSE1.MD.4	Problem Solving, Composing and Decomposing of numbers	Students will solve real world problems.
<a href="#"><u>Task 5: Digging Dinosaurs</u></a>	Performance Task <i>Small Group/ Partners/ Individual</i>	MGSE1.OA.1 MGSE1.OA.2 MGSE.1.OA.5	Problem solving	Students will practice the flexible use of numbers.
<a href="#"><u>Task 6: Meaning Using Story Problems: Change Unknown</u></a>	Constructing Task <i>Whole Group/ Small Group/ Individual</i>	MGSE1.OA.1	Problem solving with the change unknown	Students will solve real world math problems using addition and subtraction.

**Georgia Department of Education**  
 Georgia Standards of Excellence Framework  
*GSE Operations and Algebraic Thinking • Unit 3*

<u><a href="#">FAL</a></u>	<b>Performance Assessment</b>	MGSE1.OA.1	<b>FAL: Caterpillars and Leaves</b>	<b>FAL</b>
<u><a href="#">Task 7: Shape Pounds</a></u>	Constructing Task <i>Whole Group/ Small Group/ Individual</i>	MGSE1.OA.7 MGSE1.OA.8	Writing numbers sentences with a shape representing an unknown	Students will work with equality and understanding of the equal sign.
<u><a href="#">Task 8: Fact Families to Ten</a></u>	Scaffolding Task <i>Whole Group/ Small Group/ Individual</i>	MGSE1.OA.3 MGSE1.OA.4 MGSE.1.OA.5 MGSE1.OA.6	Relating addition to subtraction	Students will practice fact families using cubes and number sentences.
<u><a href="#">Task 9: Developing Meaning Using Story Problems: Initial Unknown</a></u>	Constructing Task <i>Whole Group/ Small Group/ Individual</i>	MGSE1.OA.1	Problem solving with the initial unknown	Students will solve real world math problems using addition and subtraction.
<u><a href="#">Task 10: Domino Fact Family</a></u>	Practice Task <i>Individual</i>	MGSE1.OA.6	Relating addition to subtraction	Students will construct Fact Families using dominoes.
<u><a href="#">Task 11: Candy</a></u>	Practice Task <i>Whole Group/ Small Group/ Partners</i>	MGSE.1.OA.5 MGSE1.MD.4	Graphing	Students will create a graph and use the terms most and least.
<u><a href="#">Task 12: Culminating Task : Atlanta Zoo</a></u>	<b>Culminating Task</b> <i>Individual</i>	MGSE1.OA.1 MGSE.1.OA.5 MGSE1.OA.7 MGSE1.OA.8 MGSE1.MD.4	Problem solving, working with unknowns, writing number sentences	Students will solve real world math problems involving finding combinations of numbers given a sum.

**Georgia Department of Education**  
 Georgia Standards of Excellence Framework  
*GSE Operations and Algebraic Thinking • Unit 3*

**Table 2 Concrete, Representational, Abstract Chart (CRA)**

	<b>Concrete</b>	<b>Representational</b>	<b>Abstract</b>
	Part 1: Using Manipulatives	Part 2: Drawing Pictures	Part 3: Creating Number Sentences
<b>Stage</b>	Allow students to work at their seat with various manipulatives (red and yellow counters, buttons, connecting cubes, square tiles, etc.) to help them find the number of kids left outside. Some students will need to continue to physically act out the problem multiple times before they are able to use manipulatives to represent objects within the problem.	Once students have grasped the Concrete representation of the problem, they will be ready to create pictures to represent the problem. Allow students to use crayons, pencils, and paper to draw a picture to solve the problem. Allow students to use picture representations that make sense to them (dots, squares, circles, tally marks, actual friends, etc.)	First grade students should begin creating number sentences to describe their story problems <u>after</u> the use of manipulatives and/or the creation of a picture. <b><i>Students should be introduced to the terms subtraction, difference, and number sentence throughout this unit.</i></b>
<b>Suggested</b>	<p>Suggested questions include:</p> <ul style="list-style-type: none"> <li>• How can we show/represent this?</li> <li>• How many counters are you starting with? Why?</li> <li>• How many counters are you taking away? Why?</li> <li>• Can you explain to me how you are using your counters to help you figure out how many friends are left?</li> <li>• What strategies are you using to help you find out how many friends are left?</li> <li>• Is your neighbor finding the number of friends left a different way? Can you do it a different way?</li> <li>• How did you find out how many friends were left? Can you explain that to a neighbor?</li> </ul>	<p>Suggested questions include: (In teacher modeling, use dots, etc. to show various ways to represent friends to help students not get bogged down with pictures.)</p> <ul style="list-style-type: none"> <li>• How can we show/represent this story?</li> <li>• Describe your picture for me.</li> <li>• Do you think a friend would be able to make sense of your picture?</li> <li>• How many friends did you draw?</li> <li>• How did you show the friends that left for lunch?</li> <li>• What strategies are you using to help you subtract/take away the friends that left?</li> <li>• How did you find the number of friends that were still outside?</li> <li>• Can you think of a different way to find out how many friends were outside?</li> <li>• Did your neighbor solve it the same Instead of acting out the story what could we use to represent the friends?</li> <li>• Are there any objects I could use to help me find out how many friends were still outside?</li> <li>• Is there a way you could have solved this problem differently? How do you know?</li> </ul>	<p>As students are creating number sentences for their story problems, suggested questions include:</p> <ul style="list-style-type: none"> <li>• Which number did you subtract from? Why?</li> <li>• How many did you subtract from _____?</li> <li>• Why did you subtract _____ - _____ and not the other way around?</li> <li>• Which number did you place first when you subtracted?</li> <li>• Will I get the same answer if I change the order of numbers when I subtract?</li> <li>• How did you know this was a subtraction problem?</li> <li>• Which sign did you use? Why?</li> <li>• What is the difference? What does that mean?</li> <li>• How did you find the difference? What strategies did you use?</li> <li>• How can we show/represent this story?</li> <li>• How can you check the difference to make sure it is correct?</li> <li>• Is there another way you could have solved this problem?</li> <li>• Did your neighbor solve it the same way you did or differently? How do you know?</li> </ul>

## **Task 1**

### **CONSTRUCTING TASK: Developing Meaning by using Story Problems: Result Unknown**

*Approximately 3 days*

#### **STANDARDS FOR MATHEMATICAL CONTENT**

**MGSE1.OA.1.** Use addition and subtraction within 20 to solve word problems involving situations of adding to, taking from, putting together, taking apart, and comparing, with unknowns in all positions, e.g., by using objects, drawings, and equations with a symbol for the unknown number to represent the problem.

#### **STANDARDS FOR MATHEMATICAL PRACTICE**

1. Make sense of problems and persevere in solving them. *Students determine appropriate strategies to solve word problems.*
2. Reason abstractly and quantitatively.
3. Construct viable arguments and critique the reasoning of others.
4. Model with mathematics. *Students create drawings and other visual representations of numbers and word problems.*
5. Use appropriate tools strategically.
6. Attend to precision.
7. Look for and make use of structure.
8. Look for and express regularity in repeated reasoning.

#### **BACKGROUND KNOWLEDGE/COMMON MISCONCEPTIONS/COMMON MISCONCEPTIONS**

The goal for this lesson is to expose students to real world problems, using the level of understanding (concrete, representational, or abstract) that each student needs. ([see CRA, Table 2 on](#)) Addition and subtraction can be divided into four categories: join problems, separate problems, part-whole problems, and compare problems ([see Table 1](#)). Within these four types of problems, most educators focus on addition and subtract when the result is unknown, this leads to the understanding that addition is “put together” and subtraction means to “take away”. This is a major misconception and limits the students’ understanding. One way to prevent development of this misunderstanding is to provide problem based story problems in which the students are attempting to solve not only for the result but also the change, and the initial.

Students should not complete a multitude of problems within one class period, rather they should work in depth with as few as one problem that they can know and understand completely. Students do not need to know the names of the different types of problems but they should have experience in solving all of the different types. This lesson should not be looked at to be



completed in one session, these questions should be readdressed throughout this unit and continue throughout the mathematics curriculum across the year and grade levels.

### **ESSENTIAL QUESTIONS**

- What happens when we join two quantities or take one from another?
- How can we find what is left when we take one quantity from another?

### **MATERIALS**

- Paper
- Various Manipulatives (examples: counters, based ten blocks, arithmetic rack, etc.)
- Pencils
- Crayons
- Types of Problems (cut out)
- Fill the Tree Game
- Dice
- Small counters

### **GROUPING**

Flexible Grouping (based on student needs) Depending on the story problem, this task could be solved with students working as a whole-class, small groups, or independently.

### **TASK DESCRIPTION, DEVELOPMENT AND DISCUSSION**

#### **Part I**

The teacher will tell a story similar to the one suggested and engage in conversation about the questions provided. Continue questioning as needed until the students can answer the questions and understand what is happening in the story.

Five friends are playing outside, five more join them.

- Will that make more or less friends playing together? How do you know?
- What can you do to figure out the total number of friends playing outside now?

Later on, 3 friends had to go inside for lunch.

- How many did that leave playing outside?
- Are there more students inside or outside now? How do you know?
- What did you do to figure it out?
- How was that different from what we did at the beginning of the story, in other words, how did the “actions” for solving or thinking about the problem change?
- How could we use a number line to model the actions in this story?”

**Georgia Department of Education**  
Georgia Standards of Excellence Framework  
*GSE Operations and Algebraic Thinking • Unit 3*

**Part II**

Sample problems have been provided. Copy the problems, cut them out to give to students and/or flexible groups. Each set can be done within small groups or within centers/work stations. The sample word problems are designed to give a conceptual understanding of addition and subtraction of two numbers. Students should explore these problems using the CRA model. Refer to the CRA table on page 15 for explanation and questioning.

- C- Concrete: Using Manipulatives (acting out)
- R- Representational: Drawing Pictures
- A- Abstract: Creating Number Sentences

“In the classroom, this approach is a facilitating framework for students to create meaningful connections between concrete, representational, and abstract levels of thinking and understanding. Students’ learning starts out with visual, tangible, and kinesthetic experiences to establish basic understanding, and then students are able to extend their knowledge through pictorial representations (drawings, diagrams, or sketches) and then finally are able to move to the abstract level of thinking, where students are exclusively using mathematical symbols to represent and model problems.” *Hauser, Jane. Concrete-representational-abstract instructional approach.*

Suggestion for lesson pacing:

- Day one- Students will solve problems within small groups
- Day two- Students will solve problems within partners
- Day three- Students will solve problems independently

The problems listed below are examples from the four types of addition/subtraction problems. The numbers and topics of each problem can be adjusted based on the interest and ability of your students. All four types of problems should be focused in a variety of ways.

*Join Problems:*

When joining two quantities, three different amounts are used: the initial amount, the change amount, and the result amount (or whole). (VDW)

*Example:* The other day I saw 5 dogs chasing a ball in the park. Then, three more dogs came and joined them playing ball. How many dogs were playing in the park?  $5+3=$  \_\_\_\_

*Separate Problems:*

Within separate problems, your initial amount is the whole. This differs from a joining problem because within a joining problem your result is your whole. (VDW)

*Example:* Jack has 11 lizards in a cage. 4 escape. How many are left?  $11-4=$  \_\_\_\_

Part-Part-Whole is the combining of two quantities to create a whole. The combination can take place physically, or it can be asked to be completed mentally.

*Example:* Jessica has 7 nickels and 3 dimes. How many coins does Jessica have all together?  $7+3=$  \_\_\_\_

**Georgia Department of Education**  
Georgia Standards of Excellence Framework  
*GSE Operations and Algebraic Thinking • Unit 3*

*Comparing Problems:*

Comparing problems do not focus on the operation, but rather the relationship between two quantities. This relationship can be stated or it can be implied by using terms of greater than or less than. (VDW)

*Example:* Sarah has 7 dogs. Katie has 12 dogs. How many more dogs does Katie have than Sarah?  $12-7=$  \_\_\_\_ or  $7+$  \_\_\_\_  $=12$

**Part III**

Students will play “Fill the Tree” with a partner. Each group will need one game board, different color chips or counters for each player and a pair of 6-sided dice. Each player will determine the color chips or counters they will be. Player one will roll the dice, find the sum, and cover the sum with a chip or counter. Player two will repeat the process. Players will take turns until the board is covered. The player to cover the last spot wins. If a sum is already covered the player loses that turn.

**FORMATIVE ASSESSMENT QUESTIONS**

See suggested questioning located within task description and [CRA Table](#).

**DIFFERENTIATION**

**Extension:**

- Allow students to work with numbers larger than 20 without regrouping.
- Ask students to create and solve their own story problems.

Note: Students typically create addition problems. Check students’ problems to make sure they are creating subtraction problems too.

**Intervention**

- Allow students to work through the stages at a pace that is appropriate to their developmental level. This will provide students with the remediation they need to understand the concept of comparing numbers. Continue to allow them to work with manipulatives as much as needed. At times, partner them with students who are very articulate about their mathematical thinking so they can hear (through conversations) how these students have made sense of the problems.

**Join: Result Unknown**

The other day I saw 6 dogs chasing a ball in the park. Then, seven more dogs came and joined them playing ball. How many dogs were playing in the park?  $6+7=$  \_\_\_\_\_

There were three people swinging on the swings. One more person joined them. How many children are on the swings?  $3+1=$  \_\_\_\_\_

**Separate: Result Unknown**

There were thirteen chattering monkeys. Five fell asleep. How many monkeys are still chattering?  $13-5=$  \_\_\_\_\_

Pete has 20 mice in a cage. 12 escape. How many are left?  $20-12=$  \_\_\_\_\_

There were eight bunnies at the pet store. Three went home with a new family. How many bunnies were still at the pet store?  $8-3=$  \_\_\_\_\_

Today at lunch I had twelve chicken nuggets on my tray. I ate seven of my chicken nuggets. How many did I not eat?  $12-7=$  \_\_\_\_\_

Sarah and Katie had 15 gumballs. Sarah ate 6 of the gumballs. How many are left for Katie?  $15-6=$  \_\_\_\_\_

**Part-Part-Whole: Whole Unknown**

Tony has 8 pennies and 5 dimes.  
How many coins does Tony have all together?  $8+5=$  \_\_\_\_

Cecil has 10 baseball cards and Anthony has 8 baseball cards.  
The boys put all their baseball cards into one box. How many baseball cards will be in their box?  $10+8=$  \_\_\_\_

**Compare: Difference Unknown**

One litter has eleven kittens.  
Another litter has six kittens. How many more kittens does the first litter have?  $11-6=$  \_\_\_\_ or  $6+$  \_\_\_\_  $=11$

Pete has 9 mice. Max has 13 mice. How many more mice does Max have than Pete?  $13-9=$  \_\_\_\_ or  $9+$  \_\_\_\_  $=13$

In my bag of candy, I have thirteen yellow candies and eight red candies. How many more red candies do I have than yellow candies?  $13-8=$  \_\_\_\_ or  $8+$  \_\_\_\_  $=13$

I picked some flowers for my mother. I gave her twenty daisies and fifteen roses. How many more daisies did I give her than roses?  $20-15=$  \_\_\_\_ or  $15+$  \_\_\_\_  $=20$

# Fill the Tree

**Materials:** game board, different color chips or counters for each player, pair of 6-sided dice.

**Number of Players:** Two - both players will use one game board

**Directions:** Each player will determine the color chips or counters they will be. Player one will roll the dice, find the sum, and cover the sum with a chip or counter. Player two will repeat the process. Players will take turns until the board is covered. The player to cover the last spot wins. If a sum is already covered the player loses that turn.

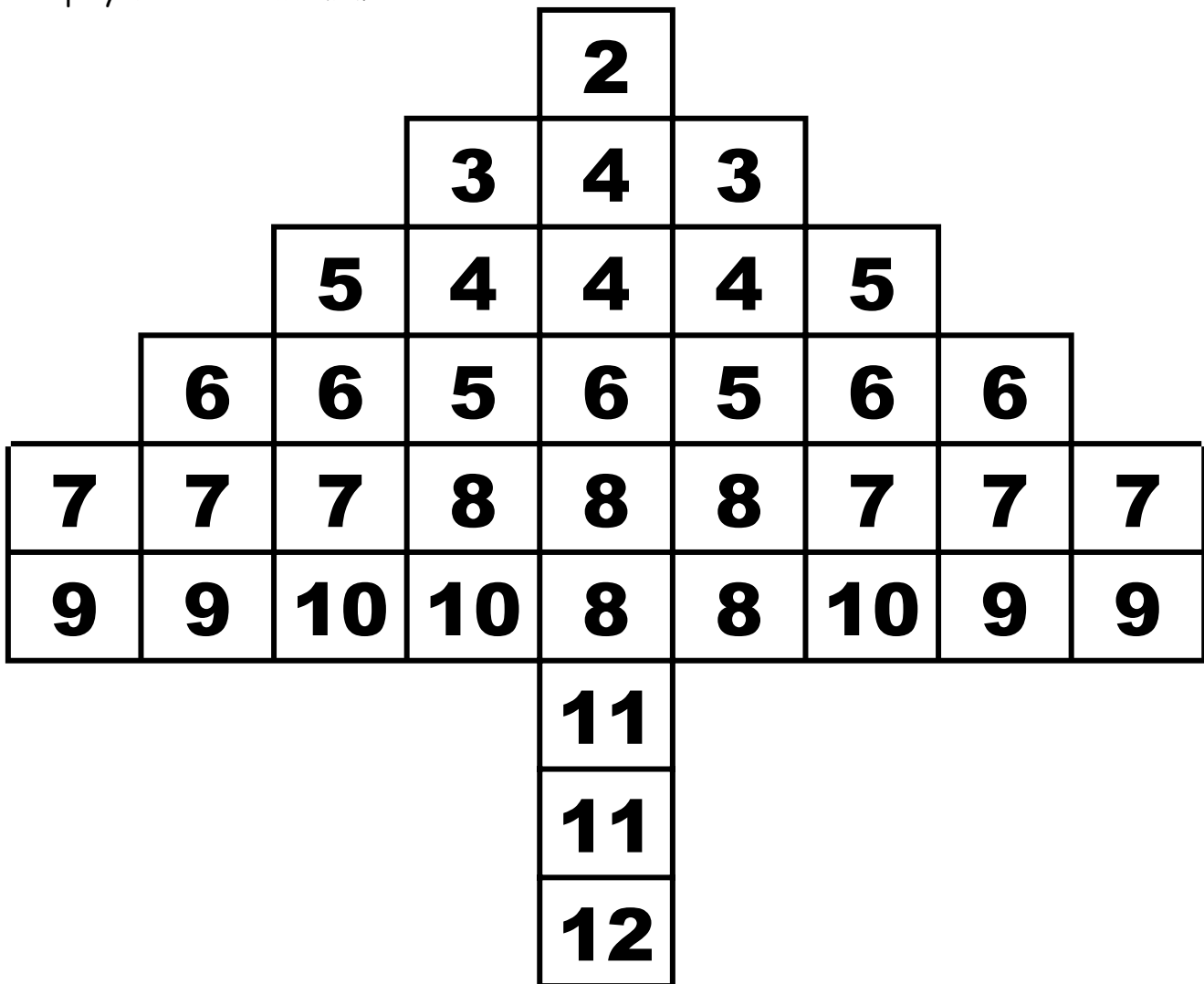

## **Task 2**

### **Scaffolding: Lots of Dots**

Approximately 2-3 Days Adapted from NCTM Navigating Through Algebra K-2

### **STANDARDS FOR MATHEMATICAL CONTENT**

**MGSE1.OA.3.** Apply properties of operations as strategies to add and subtract. Examples: If  $8 + 3 = 11$  is known, then  $3 + 8 = 11$  is also known. (Commutative property of addition.) To add  $2 + 6 + 4$ , the second two numbers can be added to make a ten, so  $2 + 6 + 4 = 2 + 10 = 12$ . (Associative property of addition.)

**MGSE1.OA.4.** Understand subtraction as an unknown-addend problem. For example, subtract  $10 - 8$  by finding the number that makes 10 when added to 8.

**MGSE1.OA.5.** Relate counting to addition and subtraction (e.g., by counting on 2 to add 2).

**MGSE1.OA.6**      **Add and subtract within 20.**

**a. Use strategies such as counting on; making ten (e.g.,  $8 + 6 = 8 + 2 + 4 = 10 + 4 = 14$ ); decomposing a number leading to a ten (e.g.,  $13 - 4 = 13 - 3 - 1 = 10 - 1 = 9$ ); using the relationship between addition and subtraction (e.g., knowing that  $8 + 4 = 12$ , one knows  $12 - 8 = 4$ ); and creating equivalent but easier or known sums (e.g., adding  $6 + 7$  by creating the known equivalent  $6 + 6 + 1 = 12 + 1 = 13$ ).**

**b. Fluently add and subtract within 10.**

### **STANDARDS FOR MATHEMATICAL PRACTICE**

1. Make sense of problems and persevere in solving them.
2. Reason abstractly and quantitatively. *Students determine different number combinations to find the sum and difference.*
3. Construct viable arguments and critique the reasoning of others.
4. Model with mathematics.
5. Use appropriate tools strategically.
6. Attend to precision.
7. Look for and make use of structure. *Students manipulate numbers to determine missing addend.*
8. Look for and express regularity in repeated reasoning.

## **BACKGROUND KNOWLEDGE/COMMON MISCONCEPTIONS**

First graders might have informally encountered negative numbers in their lives, so they think they can take away more than the number of items in a given set, resulting in a negative number below zero. Provide many problems situations where students take away all objects from a set, e.g.  $19 - 19 = 0$  and focus on the meaning of 0 objects and 0 as a number. Ask students to discuss whether they can take away more objects than what they have. (N.C. Dept. of Public Instruction)

## **ESSENTIAL QUESTIONS**

- How are addition and subtraction related?
- How can we use different combinations of numbers and operations to represent the same quantity?
- How can decomposing a number help you?

## **MATERIALS**

- Lots of Dots blackline master
- Copy one set of 6 ladybugs for each student
- Student math journals
- How Many Counters Game
- Small Counters

## **GROUPING**

whole/partner/small group task

## **TASK DESCRIPTION, DEVELOPMENT AND DISCUSSION**

### **Part I**

Students will explore finding sums, forming equations, expressions, and the Commutative Property.

Place the ladybugs (cut apart) in an envelope. Have the students count the number of dots on the ladybugs. Ask, “How many ways can you put the ladybugs together to make three, four, or five?” Discuss the different ways that the lady bugs can be put together and record the student’s responses on chart paper, as they record classmate responses in their personal math journals. Be sure to point out the variety of ways the students are coming up with. They may discover that one and two are the same as two and one. Encourage the discussion and allow students to create their own rule.



**Georgia Department of Education**  
Georgia Standards of Excellence Framework  
*GSE Operations and Algebraic Thinking • Unit 3*

Continue by having them find as many number combinations for 6, 7, and 8 as they can. They will write expressions to match their number combinations. A possible solution might be:  $7$  is  $3+4$ ,  $2+5$ ,  $1+2+4$ ,  $0+3+4$ ,  $0+2+5$ . End by having students write in their journal about the number 9.

### **Part II**

Begin to pose situations where dots are missing. For example, “All together the ladybugs have 4 spots. If one has 3 dots, how many does the other ladybug(s) have?” Record the equation  $3 + \quad = 4$ . Provide students with additional “missing dots” questions and have them record and solve the equations in their math journals.

### **Part III**

Students combine envelopes of ladybugs to represent larger quantities. They will continue to write equations with and without missing dots. They will also have opportunities to put together more than two addends.

### **Part IV**

Students should play the game, *How Many Counters?* This partner game was created to increase proficiency with number combinations. Students will need blank ten-frames, counters and a number cube. One player secretly arranges some counters on a ten-frame. The other player asks questions that can be answered “yes” or “no”, trying to gain enough clues to work out the arrangement of counters. For example: Is the top row full? Are there 8 counters? Is there an empty box in the bottom row? As players become more skilled, the number of questions can be counted. The player asking fewer questions wins.

## **FORMATIVE ASSESSMENT QUESTIONS**

- Is there another way that you could make the number?
- How did you determine the missing addend?
- Are you sure that you have found them all? Why do you think so? How do you know?
- Did you identify any patterns or rules? Explain!

## **DIFFERENTIATION**

### **Extension**

- Provide students with problems involving two expressions where one has a missing addend. For example: There were two windows with two ladybugs on each window. Both sets of ladybugs have the same number of spots. If one window has ladybugs with three spots and four spots, and the other window has one ladybug with 2 spots, how many spots does the other lady bug have? Write an equation to solve this problem.

**Intervention**

- Complete this task in a smaller setting. Students may work in pairs and the sum may not be greater than five. Gradually increase the sum until the concept is grasped.

## Lots of Dots

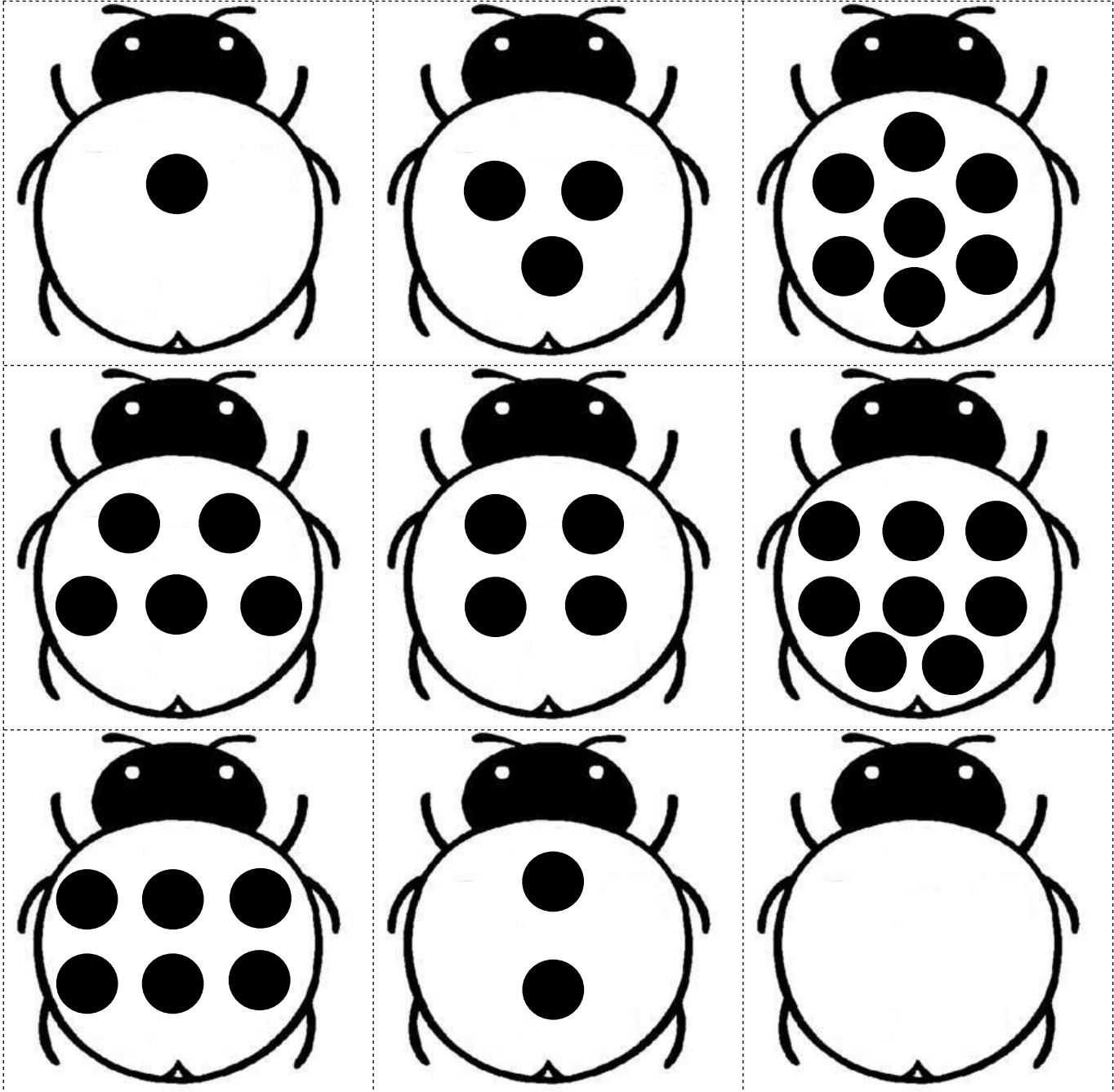

## How Many Counters?

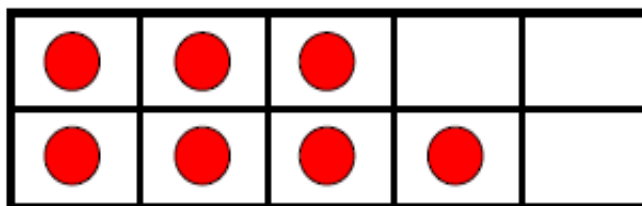

**Materials:** Blank ten-frames, one or more per player

Counters

A number cube

**Players:** Two

**Rules:** One player secretly arranges some counters on a ten-frame. The other player asks questions that can be answered yes or no, trying to gain enough clues to work out the arrangement of counters. For example: Is the top row full? Are there 8 counters? Is there an empty box in the bottom row?

**Variation:** As players become more skilled, the number of questions can be counted. The player asking fewer questions wins.

## How Many Counters?





### Task 3

## **CONSTRUCTING TASK: What Numbers Can You Make?**

*Approximately 1 day*

*\*Adapted from Developing Number Concepts, Addition and Subtraction*

### **STANDARDS FOR MATHEMATICAL CONTENT**

**MGSE1.OA.3.** Apply properties of operations as strategies to add and subtract.

Examples: If  $8 + 3 = 11$  is known, then  $3 + 8 = 11$  is also known. (Commutative property of addition.) To add  $2 + 6 + 4$ , the second two numbers can be added to make a ten, so  $2 + 6 + 4 = 2 + 10 = 12$ . (Associative property of addition.)

**MGSE1.OA.4.** Understand subtraction as an unknown-addend problem. For example, subtract  $10 - 8$  by finding the number that makes 10 when added to 8.

**MGSE1.OA.5.** Relate counting to addition and subtraction (e.g., by counting on 2 to add 2).

**MGSE1.OA.6**      **Add and subtract within 20.**

**a. Use strategies such as counting on; making ten (e.g.,  $8 + 6 = 8 + 2 + 4 = 10 + 4 = 14$ ); decomposing a number leading to a ten (e.g.,  $13 - 4 = 13 - 3 - 1 = 10 - 1 = 9$ ); using the relationship between addition and subtraction (e.g., knowing that  $8 + 4 = 12$ , one knows  $12 - 8 = 4$ ); and creating equivalent but easier or known sums (e.g., adding  $6 + 7$  by creating the known equivalent  $6 + 6 + 1 = 12 + 1 = 13$ ).**

**b. Fluently add and subtract within 10.**

**MGSE1.MD.4.** Organize, represent, and interpret data with up to three categories; ask and answer questions about the total number of data points, how many in each category, and how many more or less are in one category than in another.

### **STANDARDS FOR MATHEMATICAL PRACTICE**

1. Make sense of problems and persevere in solving them.
2. Reason abstractly and quantitatively. *Students determine different number combinations to find the sum and difference.*
3. Construct viable arguments and critique the reasoning of others.
4. Model with mathematics.
5. Use appropriate tools strategically.
6. Attend to precision.
7. Look for and make use of structure. *Students manipulate numbers to determine missing addend.*

8. Look for and express regularity in repeated reasoning.

**BACKGROUND KNOWLEDGE/Common Misconceptions**

The goal of this activity is for students to understand number combinations. There may be multiple ways to represent a number, but listen for how the students explain themselves.

**ESSENTIAL QUESTIONS**

- How are addition and subtraction related?
- How can we use different combinations of numbers and operations to represent the same quantity?
- How can decomposing a number help you?

**MATERIALS**

- Connecting cubes
- What Number Can You Make- Recording Sheet
- I Spy Addition- Game
- Deck of Playing Card

**GROUPING**

Depending on the story problem, this task could be solved with students working as a whole-class, small groups, or independently.

**TASK DESCRIPTION, DEVELOPMENT AND DISCUSSION**

**Part I**

Make 5 stacks of connecting cubes, each stack a different color and having no more than 5 cubes. Show your five stacks to the class and have them build the same stacks to match yours. For example:

“Build these stacks exactly like mine.”

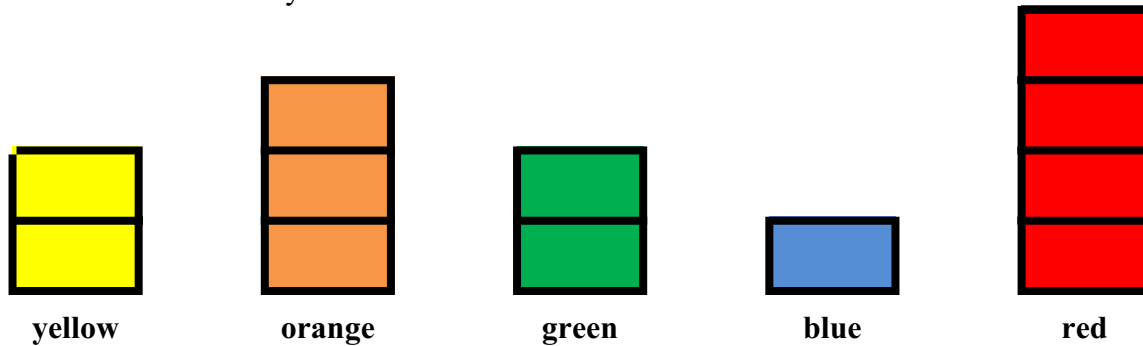

The object of this activity is to find out which numbers it is possible for children to combine using these stacks singly and in combination. The students may use more than one stack to achieve their goal number, but they should not physically connect two stacks, nor should they disassemble a stack.

Once the group has built their five stacks, give them a number to create. Begin by asking them, “Can you pick up four?” Most of your students will achieve this by picking up the red stack. Then ask the students if there are any other ways that they can pick up four. You are looking for students to pick up more than one stack, such as the orange and blue stacks or the yellow and green stacks. Ask your students to show example how they know that they have picked up the correct number. This will help them to communicate their strategies and to reinforce the Standards for Mathematical Practice. Expected responses could be, “The yellow stack has two and the green stack has two. Two and two makes four cubes.”

Continue this practice building other numbers, each time recording the number sentences on the anchor chart.

This activity can be done over and over using different combinations of stacks. Pose questions such as:

- What happens if you didn’t have a “one” stack?
- What would happen if all the stacks had the same number of cubes?
- What is the largest number we could make?
- What is the smallest number we could make?



**Georgia Department of Education**  
Georgia Standards of Excellence Framework  
*GSE Operations and Algebraic Thinking • Unit 3*

**Part II**

Have the students repeat the activity using their five cube trains to make each of the numbers from one to ten in as many ways as possible. However, this time, have them record their results by making a table on the “What Numbers Can You Make?” recording sheet. If they can’t make a particular number, they do not fill in anything for that number. If they can make the number, they record each combination they use to make it, example 2+3. Note that some combinations will be repeated if children have different colored trains of the same length.

**Part III**

Students should work with a partner to play, *I Spy Addition* to increase fluency with addition. Students will need a deck of playing cards, with face cards removed. Aces will count as 1. Arrange the cards face up in 5 rows with each row containing 8 cards. Player one will find a number combination and tell player two ONLY the sum. *I spy two cards that add to 12*. Player two looks for 2 cards next to each other, horizontally, vertically or diagonally that create a combination with the same sum that player one saw. It does not have to be the exact match that player one spotted, as long as the combination shares the same sum. If player two finds the combination, they get to pick up the cards. If player two cannot find the combination, player one gets to pick up the cards. As cards are picked up, the remaining cards are shifted to fill in the spaces. Play will continue until all that cards have been collected. The winner is the player with the most cards.

**FORMATIVE ASSESSMENT QUESTIONS**

- According to your graph, which numbers are you able to create the most ways? Why do you think that is?
- What number did you use often to construct larger numbers?
- Does your graph look like your neighbors? Why do you think?

**DIFFERENTIATION**

**Extension**

- Have students work with more cube trains, giving them more variety in their number.
- Allow students to go above 10.

**Intervention**

- Have the students use a smaller number of cube trains. This will limit the variety of ways to create a number.
- Begin with only making combinations of numbers up to five.

Georgia Department of Education  
Georgia Standards of Excellence Framework  
*GSE Operations and Algebraic Thinking • Unit 3*

Sum	Number Combinations				
1					
2					
3					
4					
5					
6					
7					
8					
9					
10					

## I Spy Combinations - Addition

### Purpose:

The purpose of this activity is to help students develop fluent recall of number combinations to 20.

### Number of Players:

2 Players

### What you need:

- A deck of playing cards, with face cards removed. Aces will count as 1.

### What to do:

- Arrange the cards face up in 5 rows with each row containing 8 cards.
- Player one will find a number combination and tell player two ONLY the sum. *I spy two cards that add to 12*
- Player two looks for 2 cards next to each other, horizontally, vertically or diagonally that create a combination with the same sum that player one saw. It does not have to be the exact match that player one spotted, as long as the combination shares the same sum.
- If player two finds the combination, they get to pick up the cards. If player two cannot find the combination, player one gets to pick up the cards.
- As cards are picked up, the remaining cards are shifted to fill in the spaces.
- Play will continue until all that cards have been collected.
- The winner is the player with the most cards.

### Extension:

- Students will create number combinations using three cards in a row.



**Task 4**

**Performance Task: Wheel Shop**

*Approximately 2 days Adapted from the Noyce Foundation*

**STANDARDS FOR MATHEMATICAL CONTENT**

**MGSE1.OA.1.** Use addition and subtraction within 20 to solve word problems involving situations of adding to, taking from, putting together, taking apart, and comparing, with unknowns in all positions, e.g., by using objects, drawings, and equations with a symbol for the unknown number to represent the problem.

**MGSE1.OA.2.** Solve word problems that call for addition of three whole numbers whose sum is less than or equal to 20, e.g., by using objects, drawings, and equations with a symbol for the unknown number to represent the problem.

**MGSE1.OA.5.** Relate counting to addition and subtraction (e.g., by counting on 2 to add 2).

**STANDARDS FOR MATHEMATICAL PRACTICE**

1. Make sense of problems and persevere in solving them.
2. Reason abstractly and quantitatively.
3. Construct viable arguments and critique the reasoning of others. *Students defend their solution and analyzing a partner's solution.*
4. Model with mathematics. *Students use drawings, equations, and written responses to solve problems.*
5. Use appropriate tools strategically.
6. Attend to precision.
7. Look for and make use of structure.
8. Look for and express regularity in repeated reasoning.

**BACKGROUND KNOWLEDGE/COMMON MISCONCEPTIONS**

Provide opportunities for students to participate in shared problem-solving activities to solve word problems. Collaborate in small groups to develop problem-solving strategies using a variety of models such as drawings, words, and equations with symbols for the unknown numbers to find the solutions. Additionally students need the opportunity to explain, write and reflect on their problem-solving strategies. The situations for the addition and subtraction story problems should involve sums and differences less than or equal to 20 using the numbers 0 to 20.

## **ESSENTIAL QUESTIONS**

- How do you determine a missing addend?
- How can we represent a group of objects with numbers?
- How can we show and explain our thinking?

## **MATERIALS**

- Wheel Shop Pictures
- The Wheel Shop Recording Sheet
- Make Twenty Game
- Four sets of 0-20 Cards

## **GROUPING**

small group/partners/individual

## **TASK DESCRIPTION, DEVELOPMENT AND DISCUSSION**

### **Part I**

Gather all students to a common area. Ask, “What do we call this? (show a picture of a bicycle) How many wheels does a bicycle have? Who can show me how they know there are two wheels? What if I have two bicycles, how many wheels would I have?” Allow students to come up with an answer and share their strategies for determining the number of wheels.

Next, the teacher shows a picture of a go-cart, and asks, “What do we call this? How many wheels does a go-cart have? What if I had two go-carts?” Allow for responses and discuss the strategies used to determine how many wheels.

### **Part II – (student work sample below)**

Using drawings, equations, and written responses, students work cooperatively or independently to solve.

The Wheel Shop sells bicycles and go-carts. Each bicycle has only one seat and each go-cart has only one seat. There are a total of 7 seats and 18 wheels in the shop.

How many are bicycles and how many are go-carts?  
Explain how you figured it out.

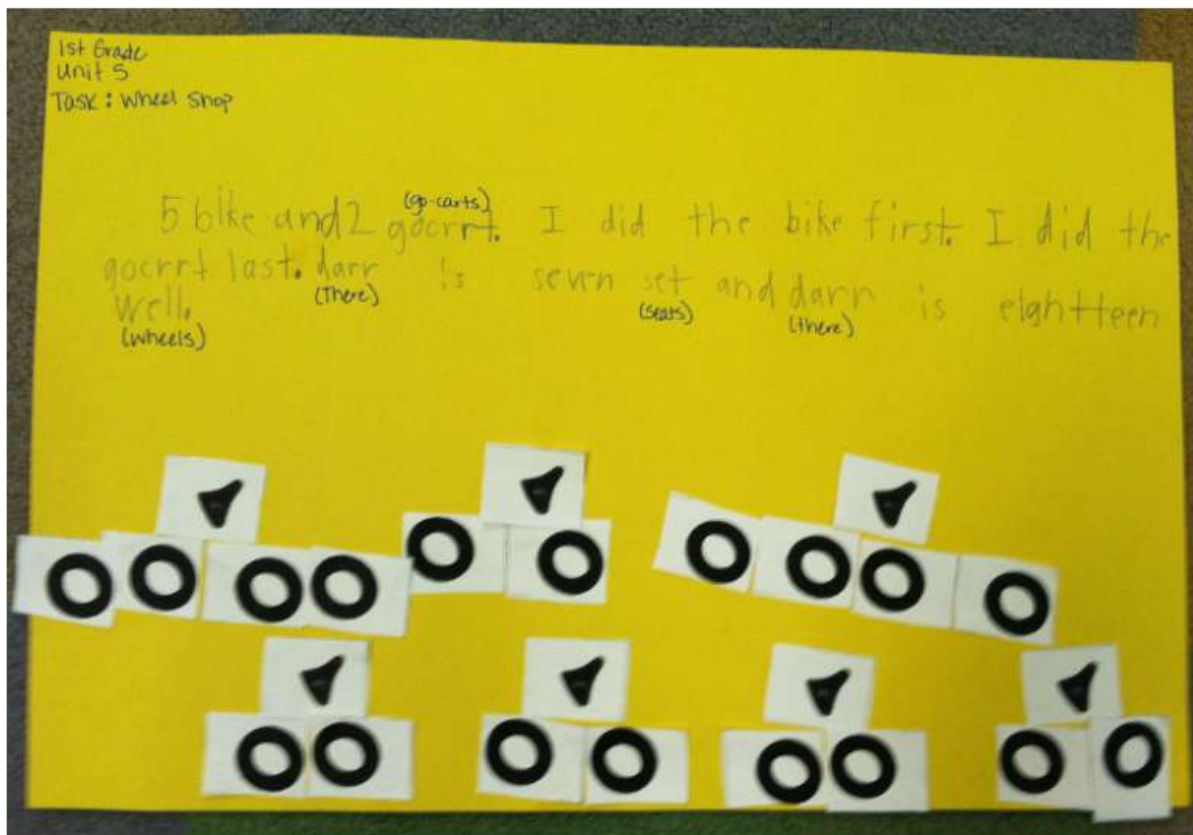

### Part III

Students should work with partners or within small groups of 4 to play *Make Twenty Game*. Groups will need 4 sets of 0-20 cards. Each player is dealt three cards and the rest of the cards are placed in a face down pile. The first player picks up a card from the pile and checks to see if he is able to make 20 and still discard one card. If he cannot, he discards a card (face up) and player two picks up a card from the face down pile or picks up the top card in the discard pile. The first player to make 20 wins.

### FORMATIVE ASSESSMENT QUESTIONS

- How did you know the number of bicycles? Go-carts?
- What strategy did you use to determine this?
- Can you write an equation/number sentence to show your thinking?
- Is this the only solution? How do you know?

## **DIFFERENTIATION**

### **Extension**

- To extend their thinking include a tricycle. There could be 5 seats and 19 wheels.

### **Intervention**

- Provide students with the amount of bicycles and go-carts, and ask them to determine the number of wheels.

Name: \_\_\_\_\_

Date: \_\_\_\_\_



## The Wheel Shop



The Wheel Shop sells bicycles and go-carts. Each bicycle has only one seat and each go-cart has only one seat. There are a total of 7 seats and 18 wheels in the shop.

How many are bicycles and how many are go-carts?

Use pictures, words, and numbers to show your math thinking.



**Georgia Department of Education**  
Georgia Standards of Excellence Framework  
*GSE Operations and Algebraic Thinking • Unit 3*

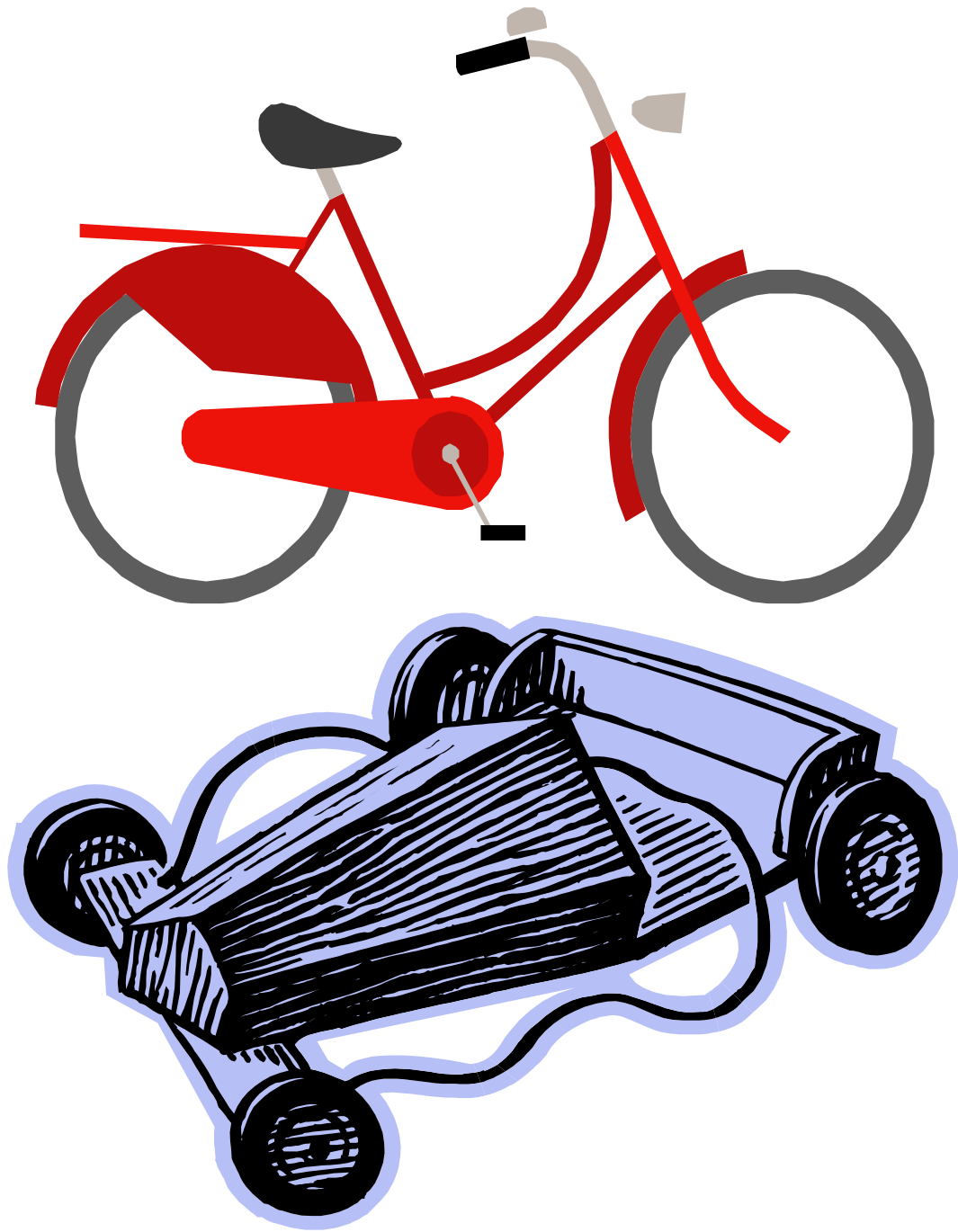

Georgia Department of Education  
Georgia Standards of Excellence Framework  
GSE Operations and Algebraic Thinking • Unit 3

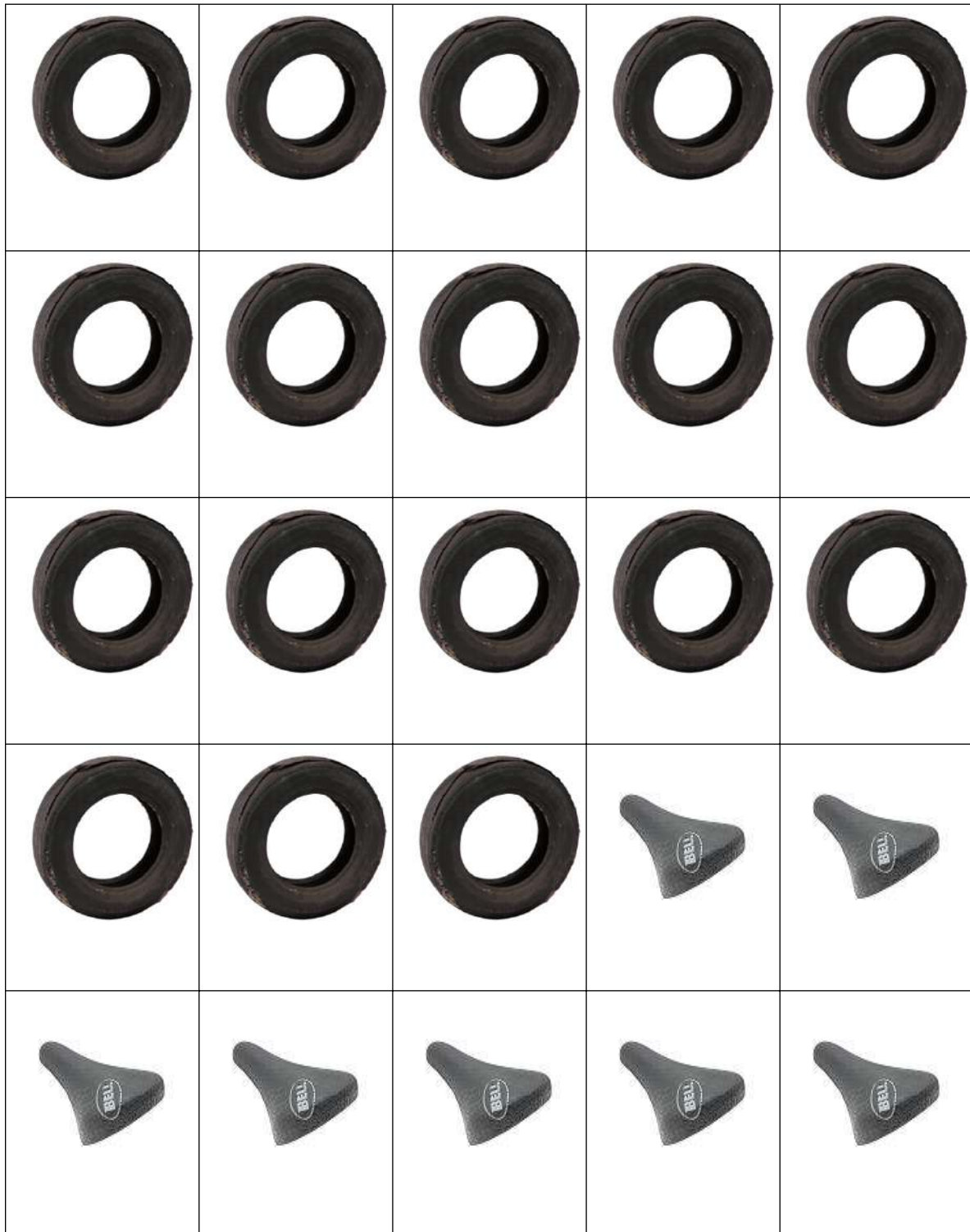



## Make Twenty

- Skills/concepts:** Addition
- Materials:** 4 sets of number cards (0 to 20)
- Number of Players:** 2 to 4
- Directions:** Each player is dealt three cards and the rest of the cards are placed in a face down pile. The first player picks up a card from the pile and checks to see if he is able to make 20 and still discard one card. If he cannot, he discards a card (face up) and player two picks up a card from the face down pile or picks up the top card in the discard pile. The first player to make 20 wins.
- Variation 1:** Deal 8 cards to each player and try to make as many combinations that make 20 as possible. Combinations can be put down as soon as they are made. The game ends when one player has no cards left after discarding one and putting down the combinations to 20. Winner has the most sets to make 20.
- Variation 2:** Change the target sum to a number between 10 and 20.

Georgia Department of Education  
Georgia Standards of Excellence Framework  
*GSE Operations and Algebraic Thinking • Unit 3*

<b>0</b>	<b>1</b>	<b>2</b>
<b>3</b>	<b>4</b>	<b>5</b>
<b>6</b>	<b>7</b>	<b>8</b>
<b>9</b>	<b>10</b>	<b>11</b>
<b>12</b>	<b>13</b>	<b>14</b>
<b>15</b>	<b>16</b>	<b>17</b>
<b>18</b>	<b>19</b>	<b>20</b>

**Task 5**

**3 ACT TASK: I want candy!**

**APPROXIMATE TIME: One class session**

**STANDARDS FOR MATHEMATICAL CONTENT**

**MGSE1.MD.4.** Organize, represent, and interpret data with up to three categories; ask and answer questions about the total number of data points, how many in each category, and how many more or less are in one category than in another.

**MGSE1.OA.1.** Use addition and subtraction within 20 to solve word problems involving situations of adding to, taking from, putting together, taking apart, and comparing, with unknowns in all positions, e.g., by using objects, drawings, and equations with a symbol for the unknown number to represent the problem.

**MGSE1.OA.5.** Relate counting to addition and subtraction (e.g., by counting on 2 to add 2).

**STANDARDS FOR MATHEMATICAL PRACTICE**

**1. Make sense of problems and persevere in solving them.** Students are required to determine a question to work through, the information they need to solve the problem, and then persevere until solving it.

**2. Reason abstractly and quantitatively.** Students are asked to make an estimate both high and low, as well as plot it on an open number line.

**3. Construct viable arguments and critique the reasoning of others.** Students are given the chance to share and critique the questions and strategies of fellow classmates.

**4. Model with mathematics.** Students will use the information given to develop a mathematical model to solve their problems.

**5. Use appropriate tools strategically.** Students can use manipulatives to aid in addition and subtraction strategies.

**6. Attend to precision.** Students will use clear and precise language when discussing their strategies and sharing their solutions with others.

**7. Look for and make use of structure.** Students will use their understanding of number relationships to make multiple combinations of 16 using three addends.

**ESSENTIAL QUESTIONS**

In order to maintain a student-inquiry-based approach to this task, it may be beneficial to wait until Act 2 to share the EQ's with your students. By doing this, students will be allowed the opportunity to be very creative with their thinking in Act 1. By sharing the EQ's in Act 2, you will be able to narrow the focus of inquiry so that the outcome results in student learning directly related to the content standards aligned with this task.

- How are the properties of addition useful when problem solving?
- How can we represent problem situations?

**Georgia Department of Education**  
Georgia Standards of Excellence Framework  
*GSE Operations and Algebraic Thinking • Unit 3*

- How can we use different combinations of numbers and operations to represent the same quantity?
- How can we represent a number in a variety of ways?

**MATERIALS**

- Act 1 Video: <http://youtu.be/9pZsGqExEDs>



- Candy Infographic:



- Act 3 Photo:
- 3-Act Recording Sheet

**GROUPING**

Whole group/student pairs/ individual task

**TASK DESCRIPTION, DEVELOPMENT AND DISCUSSION**

In this task, students will view the video and tell what they noticed. Next, they will be asked to discuss what they wonder about or are curious about. These questions will be recorded on a class chart, Padlet ([www.padlet.com](http://www.padlet.com)) and on the student recording sheet. Students will then use mathematics to answer their own questions. Students will be given information to solve the problem based on need. When they realize they don't have the information they need and ask for it, it will be given to them.

**Background Knowledge**

This task follows the 3-Act Math Task format originally developed by Dan Meyer. More information on this type of task may be found at <http://blog.mrmeyer.com/category/3acts/>. A Three-Act Task is a whole-group mathematics task consisting of 3 distinct parts: an engaging and perplexing Act One, an information and solution seeking Act Two, and a solution discussion and solution revealing Act Three. More information along with guidelines for 3-Act Tasks may be found in the *Guide to Three-Act Tasks* on [georgiastandards.org](http://georgiastandards.org) and the K-5 CCGPS Mathematics Wiki.

Prior to this task, students should have had experiences to work through several types of problem solving activities using the C-R-A method and working with three addends.

In this task students will be shown a video of kids taking candy from a table and asked what they wonder about. The main purpose of this task is to have student practice adding and subtracting within 20. Students can approach this in various ways based on the questions they ask. It is imperative that the teacher only provides information that will force a student to use addition or

**Georgia Department of Education**  
Georgia Standards of Excellence Framework  
*GSE Operations and Algebraic Thinking • Unit 3*

subtraction and not give too much information. Example: If a student's question is, "How many pieces of candy were on the table at the start of the video?" and they noticed one of the children took 4 pieces of candy in the video, they will know to subtract 4 from 16 to then determine how many pieces the other students took from the table. Remember to only give information if it is asked for.

When students are making estimates for the amount of candy each student may have taken from the table, they should also be able to justify why they believe their estimate to be reasonable, too high, or too low. Not only does this give you an idea of the strategies they use for estimation, but also gives them additional practice with adding within 30. When asked about an estimate that is too high, a student might reply, "*Student 1 took about 6 pieces of candy, Student 2 took about 7 pieces of candy, and Student 3 took about 8 pieces of candy. I know this is too high because  $6 + 7 + 8 = 21$ . 21 is greater than 16.*" It also gives students a chance to make connections and share what they know beyond the standard. For example, when asked about an estimate that is too low, a student with advanced additive counting strategies may say, "*All students took about 5 pieces of candy.  $5+5+5=15$ , which is the same as  $3 \times 5 = 15$ . 15 is one less than 16.*" These conversations are extremely important to have as students are working through each Act, so that students can demonstrate what they know beyond what is required.

Students should be able to discuss how to solve the word problems. They should also be able to picture the story in their minds including the objects and actions in the story. They should solve the problems using pictures, words, and numbers. They should act out the story to make sure pictures, words, and numbers that were used make sense.

### **COMMON MISCONCEPTIONS**

"Children must come to realize that errors provide opportunities for growth as they are uncovered and explained. Trust must be established with an understanding that it is okay to make mistakes. Without this trust, many ideas will never be shared." (Van de Walle, Lovin, Karp, Bay-Williams, Teaching Student-Centered Mathematics, Developmentally Appropriate Instruction for Grades Pre-K-2, 2014, pg. 11)

Students need to understand that there is not one correct way to solve this problem and that there will be a variety of solutions, even if the reveal provides only one solution. Some students may watch the video multiple times to count out the number of candies each student took, others may count the candies taken by one student and then work to mathematically determine the number of candies taken by the other two students, and some students may find as many ways to make 16 using three addends in hopes that they are correct in Act 3. The emphasis should be on the correct solutions and the students' ability to justify their reasoning based on the strategies they used.

### **Part I**

**Act 1 – Whole Group** - Pose the conflict and introduce students to the scenario by showing [Act 1 video](#).



(Dan Meyer <http://blog.mrmeyer.com/2011/the-three-acts-of-a-mathematical-story/>)

**“Introduce the central conflict of your story/task clearly, visually, viscerally, using as few words as possible.”**

- Show Act 1 video to students.
- Ask students what they noticed in the video. The teacher records the information.
- Ask students what they wonder about and what questions they have about what they saw. Students should share with each other first, and then the teacher records these questions (think-pair-share). The teacher may need to guide students so that the questions generated are math-related.
- Ask students to estimate answers to their questions (think-pair-share). Students will write their best estimate, then write two more estimates – one that is too low and one that is too high so that they establish a range in which the solution should occur.

**Anticipated questions students may ask and wish to answer:**

- How many pieces of candy are in each package?
- How many pieces of candy were on the table at the start?\*
- How many pieces of candy did each student take from the table? \*
- Did all students take the same amount of candy?

\*Main question(s) to be investigated

**Act 2 – Student Exploration** - Provide additional information as students work toward solutions to their questions. (Dan Meyer <http://blog.mrmeyer.com/2011/the-three-acts-of-a-mathematical-story/>) **“The protagonist/student overcomes obstacles, looks for resources, and develops new tools.”**

- During Act 2, students review the main question(s) from Act 1 and decide on the facts, tools, and other information needed to answer the question(s). When students decide what they need to solve the problem, they should ask for those things. It is pivotal to the problem solving process that students decide what is needed without being given the information up front. Some groups might need scaffolds to guide them. The teacher should question groups who seem to be moving in the wrong direction or might not know where to begin.
- The teacher provides guidance as needed during this phase. Some groups might need scaffolds to guide them. The teacher should question groups who seem to be moving in



**Georgia Department of Education**  
Georgia Standards of Excellence Framework  
*GSE Operations and Algebraic Thinking • Unit 3*

the wrong direction or might not know where to begin. Questioning is an effective strategy that can be used, with questions such as:

- What is the problem you are trying to solve?
- What do you think affects the situation?
- Can you explain what you've done so far?
- What strategies are you using?
- What assumptions are you making?
- What tools or models may help you?
- Why is that true?
- Does that make sense?

Additional Information for Act 2

- There are 16 pieces of candy
- Each student did not take the same amount of candy.

Important note: Although students will only investigate the main question(s) for this task, it is important for the teacher to not ignore student generated questions. Additional questions may be answered after they've found a solution to the main question, or as homework or extra projects.

**Act 3 – Whole Group** – Share solutions and strategies.

- Students to present their solutions and strategies and compare them.



- Reveal the solution.
- Lead discussion to compare these, asking questions such as:
  - How reasonable was your estimate?
  - Which strategy was most efficient?
  - Can you think of another method that might have worked?
  - What might you do differently next time?

**Act 4, The Sequel** - “The goals of the sequel task are to a) challenge students who finished quickly so b) I can help students who need my help. It can't feel like punishment for good work. It can't seem like drudgery. It has to entice and activate the imagination.” Dan Meyer

<http://blog.mrmeyer.com/2013/teaching-with-three-act-tasks-act-three-sequel/>

- Challenge students to answer one of the student generated questions.
- Challenge students to identify why the candy cannot be divided evenly among the children. (Many students will assume that the candy can be divided evenly because 16 is an even number. However, 3 is not an even number and so the candy cannot be divided evenly among the students.)

**FORMATIVE ASSESSMENT QUESTIONS**

- How reasonable was your estimate?
- What might you do differently next time?
- What worked well for you this time?
- What model did you use?

- What organizational strategies did you use?

## **Part II**

**Journal Writing:** Have students reflect on the task and write (or blog) about what they perceived to be challenging about the task and enjoyable about the task. Pose questions like, *How can we represent a number in a variety of ways? What surprised you most during the reveal? What strategies did you use to solve this problem?* Encourage students to use mathematical language and make connections to the task.

## **DIFFERENTIATION**

### **Extension**

- *How can you organize the information in the video?* Students may use charts or tables to represent their mathematical thinking.
- Challenge students to find out how many pieces of individual candy each student has and then how many total pieces of candy there are if there are 15 small round pieces in each roll of candy.

### **Intervention**

- Show students the infographic that reveals the amount of candy that one of the students took to help them work towards finding a solution.
- Allow students to use manipulatives to make number combinations to 16.

Act 2:



Act 3:





Unit 5: Act 3

Skitch

**Georgia Department of Education**  
 Georgia Standards of Excellence Framework  
*GSE Operations and Algebraic Thinking • Unit 3*

Name \_\_\_\_\_ Date \_\_\_\_\_

**3 Act Task Recording Sheet: I want candy!**

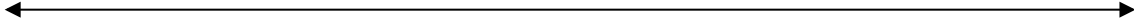
<b>What problem are you trying to figure out?</b>		
<b>What information do you already know?</b>	<b>What information do you need to solve the problem?</b>	
<b>Make an estimate.</b>	<b>Write an estimate that's too low.</b>	<b>Write an estimate that's too high.</b>
Student 1:	Student 1:	Student 1:
Student 2:	Student 2:	Student 2:
Student 3:	Student 3:	Student 3:
How do you know this is a reasonable estimate?	How do you know this estimate is too low?	How do you know this estimate is too high?
<b>Show your estimates on a number line:</b>		
Student 1:		
		
Student 2:		
		
Student 3:		
		

**Show your mathematical thinking using pictures, numbers, or words.**

**What comparative sentences can you write to describe the amount of candy the students took from the table?** (Phrases like “greater than”, “less than”, “equal to” could be helpful.)

**What is your conclusion?**

**Task 6**

**PERFORMANCE TASK: Digging Dinosaurs**

*Approximately 1 day Adapted from the Noyce Foundation*

**STANDARDS FOR MATHEMATICAL CONTENT**

**MGSE1.OA.1.** Use addition and subtraction within 20 to solve word problems involving situations of adding to, taking from, putting together, taking apart, and comparing, with unknowns in all positions, e.g., by using objects, drawings, and equations with a symbol for the unknown number to represent the problem.

**MGSE1.OA.2.** Solve word problems that call for addition of three whole numbers whose sum is less than or equal to 20, e.g., by using objects, drawings, and equations with a symbol for the unknown number to represent the problem.

**MGSE1.OA.5.** Relate counting to addition and subtraction (e.g., by counting on 2 to add 2).

**STANDARDS FOR MATHEMATICAL PRACTICE**

1. Make sense of problems and persevere in solving them.
2. Reason abstractly and quantitatively.
3. Construct viable arguments and critique the reasoning of others. *Students analyze classmates work samples and giving feedback.*
4. Model with mathematics. *Students use drawings, equations, and written responses.*
4. Use appropriate tools strategically.
5. Attend to precision.
6. Look for and make use of structure.
7. Look for and express regularity in repeated reasoning.

**BACKGROUND KNOWLEDGE/COMMON MISCONCEPTIONS**

Provide opportunities for students to participate in shared problem-solving activities to solve word problems. Collaborate in small groups to develop problem-solving strategies using a variety of models such as drawings, words, and equations with symbols for the unknown numbers to find the solutions. Additionally, students need the opportunity to explain, write and reflect on their problem-solving strategies. The situations for the addition and subtraction story problems should involve sums and differences less than or equal to 20, using the numbers 0 to 20.

## **ESSENTIAL QUESTIONS**

- How does decomposing a number help you in a problem solving situation?
- How do number sentences help you explain your thinking?
- How can we represent a number in a variety of ways?

## **MATERIALS**

- Digging Dinosaurs Blackline Master
- Pencil and paper
- Digging Dino Water Template
- Ten Frame
- Counters

## **GROUPING**

small group/partners/individual

## **TASK DESCRIPTION, DEVELOPMENT AND DISCUSSION**

### **Part I**

Gather students in a common area. (Teacher holds up the picture) “Tell me about this picture? What do you see?” (Teacher solicits answers from students) “How many dinosaur feet do you see in this picture?” How many legs does a dinosaur have? Which dinosaurs have 2 legs? Which dinosaurs have 4 legs? Are there any other dinosaurs with a different number of legs? How many dinosaurs are standing in the lake? Explain why you think it would be that number. Can you draw a complete drawing of the dinosaurs standing in the lake? Can you show how you got your answer? (At the end of the investigation have students either discuss or dictate a response to the summary questions). (Teacher solicits answers from students and then states that the class will investigate this question) “We are going to try and figure out how many dinosaurs are standing in the lake.”

Using drawings, equations, and written responses, students work cooperatively or independently to solve.

How many dinosaurs are standing in the lake? Explain why you think it would be that number. Can you illustrate a complete drawing of the dinosaurs standing in the lake? Can you show how you got your answer?  
(At the end of the investigation have students either discuss or dictate a response to the summary questions). (Teacher solicits answers from students and then states that the class will investigate this question) “We are going to try and figure out how many dinosaurs are standing in the lake.”

**Part II**

Students will create their own problem using the Digging Dino Water Template. They will then exchange their problems with a partner. Give students the opportunity to share with the class.

**Part III**

Students should play *Ten Frame Flash* in small groups for further practice with addition and subtraction. The first player shows a ten-frame for a count of three, then hides it while the other players place counters in the same positions on their frames from memory. The 'flasher' shows the card again and helps each player check his/her display. After three cards the next player becomes the 'flasher' and so on, until everyone has had a turn.

**QUESTIONS FOR FORMATIVE STUDENT ASSESSMENT**

- How many dinosaurs are standing in the lake?
- Explain why you think it would be that number.
- Can you draw a complete drawing of the dinosaurs standing in the lake?
- Can you show how you got your answer?

**DIFFERENTIATION**

**Extension**

- Add additional dinosaur legs, have students describe what has changed and how their solution has changed.
- Find an additional solution, using different number combinations.

**Intervention**

- Allow students to complete problem using manipulatives in a one-on-one interview-style setting.



Name: \_\_\_\_\_

Date: \_\_\_\_\_

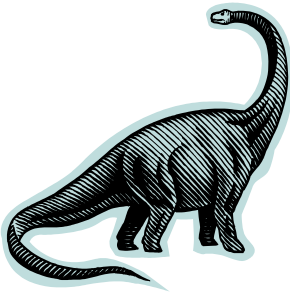

## Digging Dinosaurs

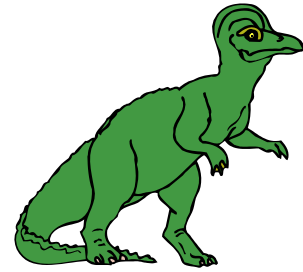

You are swimming under water in a lake and you see dinosaur feet in the water. You don't want to go to the surface in case they are not friendly dinosaurs. Below is a picture of what you see.

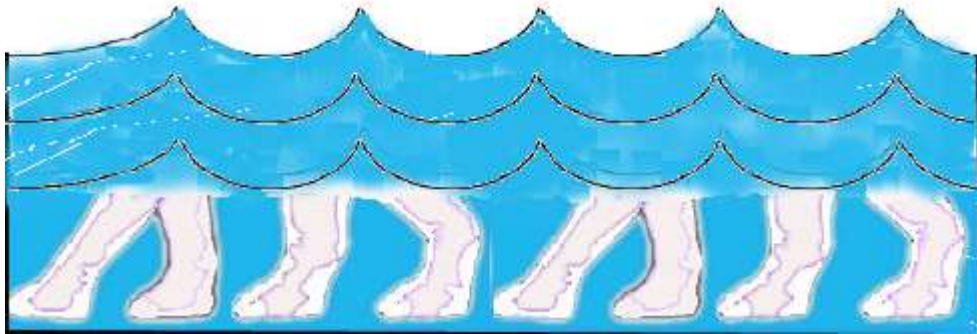

How many dinosaurs are standing in the lake?

Explain how you know. Use words and mathematical language to explain your solution.

**Georgia Department of Education**  
Georgia Standards of Excellence Framework  
*GSE Operations and Algebraic Thinking • Unit 3*

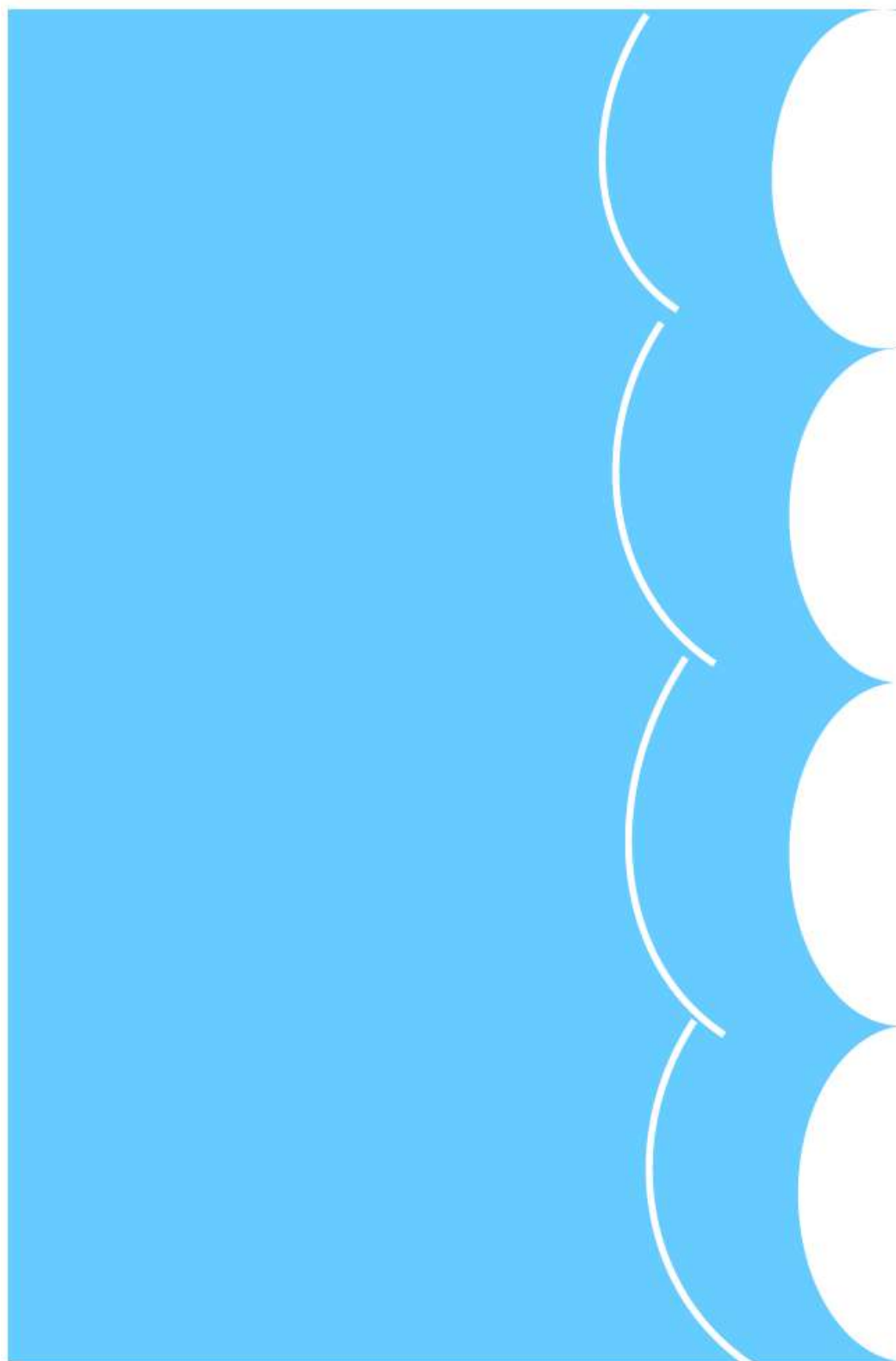

## Ten Frame Flash

- Materials:** Ten-frames with dot arrangements  
Counters  
A blank ten-frame for each player
- Players:** four
- Rules:** The first player shows a ten-frame for a count of three, then hides it while the other players place counters in the same positions on their frames from memory. The 'flasher' shows the card again and helps each player check his/her display. After three cards the next player becomes the 'flasher' and so on, until everyone has had a turn.
- Variation 1:** Points can be awarded for each correct response. The player with the most points wins.
- Variation 2:** This game can be played as a whole class with one student using overhead versions of the filled ten frames to flash for the whole class.
- Variation 3:** A more difficult addition game can be played by flashing two ten frames at a time and having students show the sum of the two ten frames on one ten frame (or two if the sum is greater than 10).
- Variation 4:** A more difficult subtraction game can be played by flashing two ten frames at a time and having **students show the difference on one ten frame.**

This activity was adapted from:

<http://www.nrich.maths.org.uk/prime/may99/staff.htm>

**Georgia Department of Education**  
Georgia Standards of Excellence Framework  
*GSE Operations and Algebraic Thinking • Unit 3*





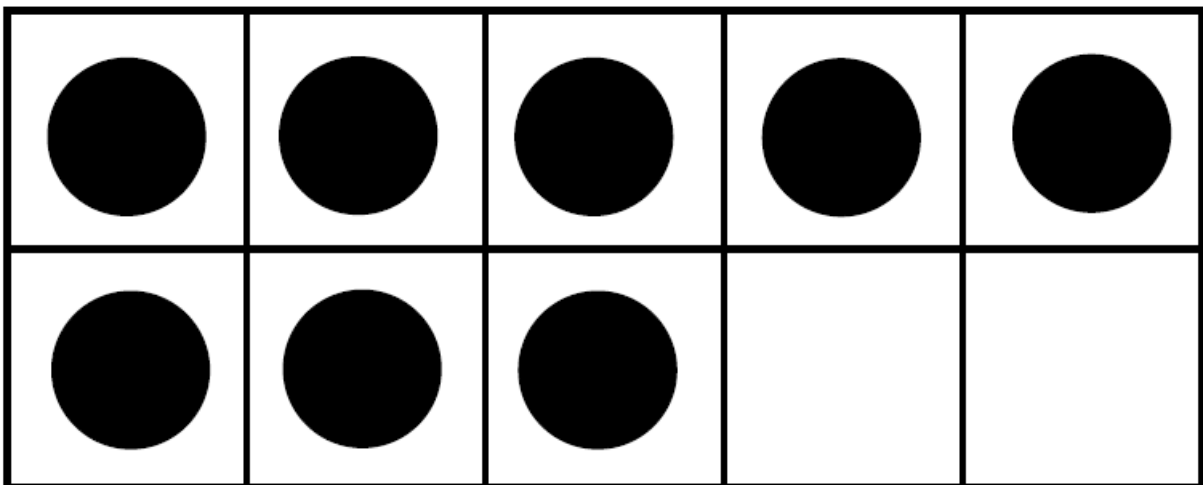
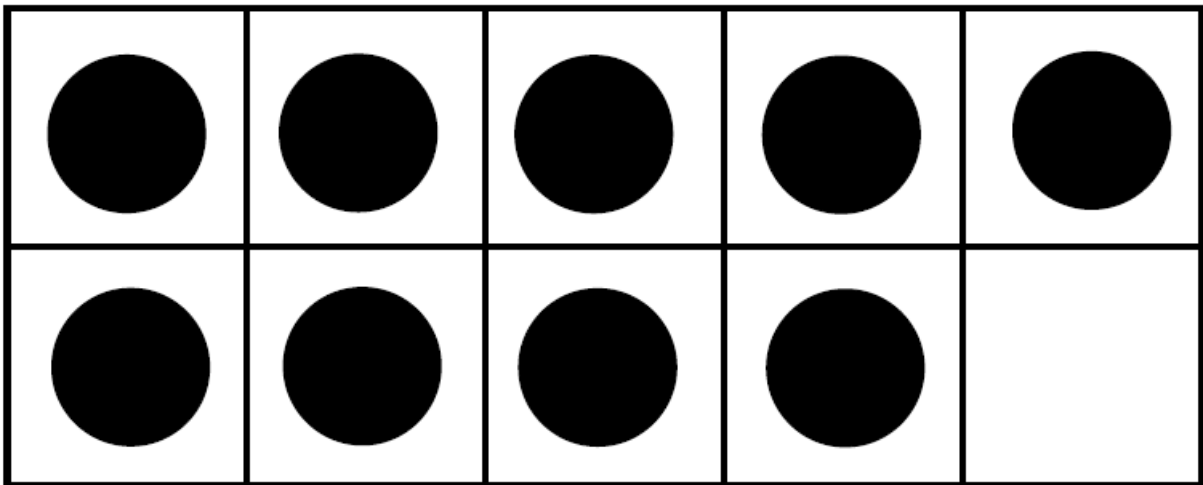
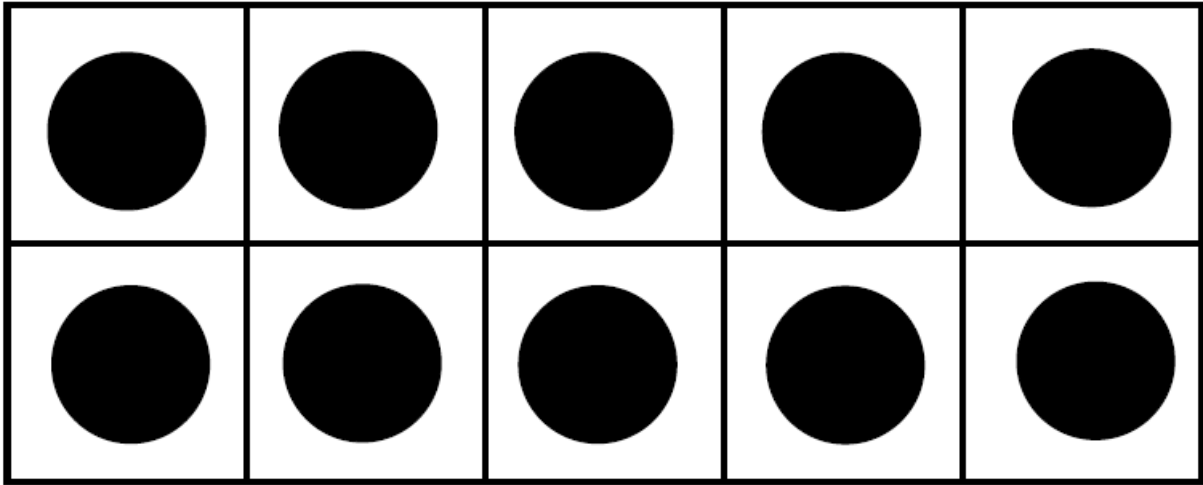

Georgia Department of Education  
Georgia Standards of Excellence Framework  
*GSE Operations and Algebraic Thinking • Unit 3*

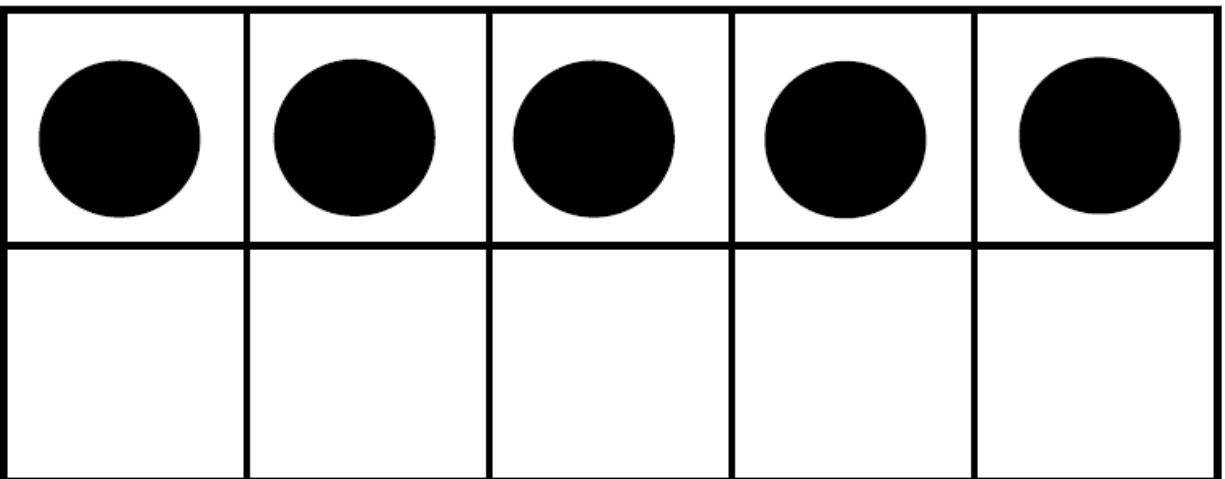
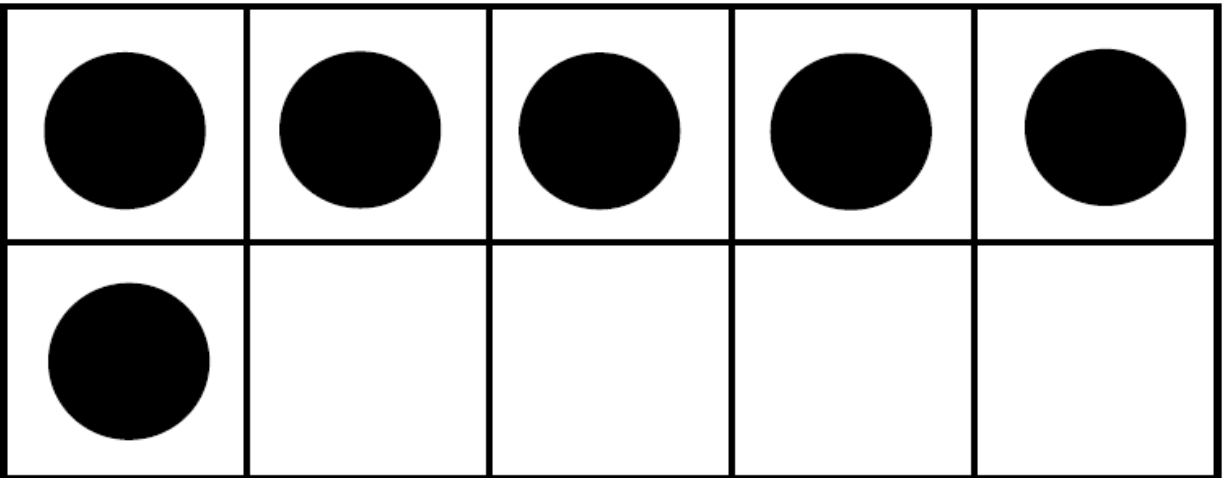
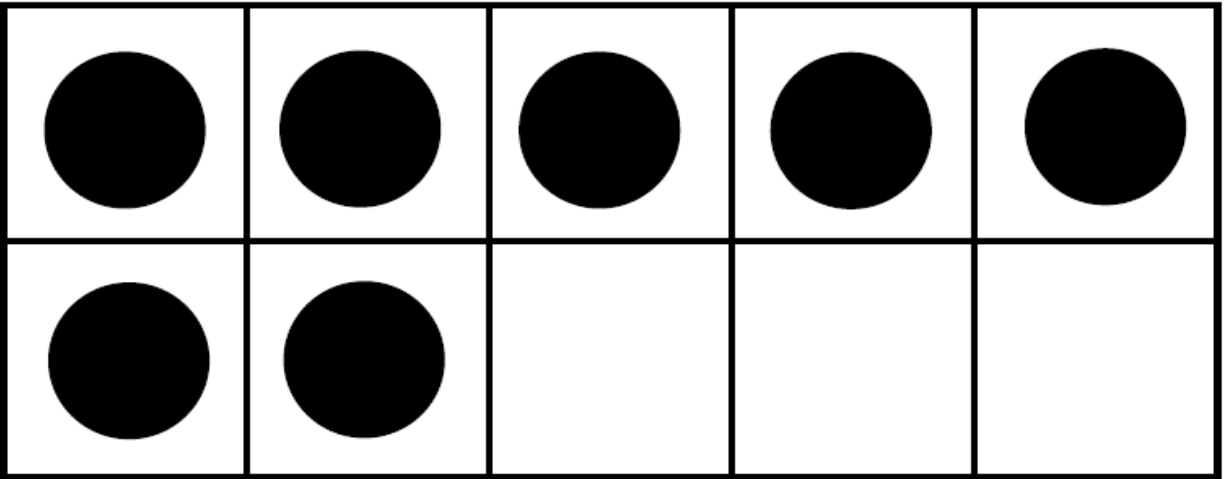





Georgia Department of Education  
Georgia Standards of Excellence Framework  
*GSE Operations and Algebraic Thinking • Unit 3*



Georgia Department of Education  
Georgia Standards of Excellence Framework  
*GSE Operations and Algebraic Thinking • Unit 3*

Georgia Department of Education  
Georgia Standards of Excellence Framework  
*GSE Operations and Algebraic Thinking • Unit 3*





**Task 7**

**CONSTRUCTING TASK:** Developing Meaning by using Story Problems: Change Unknown

*Approximately 2-3 days*

**STANDARDS FOR MATHEMATICAL CONTENT**

**MGSE1.OA.1.** Use addition and subtraction within 20 to solve word problems involving situations of adding to, taking from, putting together, taking apart, and comparing, with unknowns in all positions, e.g., by using objects, drawings, and equations with a symbol for the unknown number to represent the problem.

**STANDARDS FOR MATHEMATICAL PRACTICE**

1. Make sense of problems and persevere in solving them. *Students determine appropriate strategies to use to solve problems.*
2. Reason abstractly and quantitatively.
3. Construct viable arguments and critique the reasoning of others.
4. Model with mathematics. *Students use pictures, drawings, and other representations to solve problems.*
5. Use appropriate tools strategically.
6. Attend to precision.
7. Look for and make use of structure.
8. Look for and express regularity in repeated reasoning.

**BACKGROUND KNOWLEDGE/COMMON MISCONCEPTIONS**

The goal for this lesson is to revisit real world problems, using the level of understanding (concrete, representational, or abstract) that each student needs. ([see CRA Table](#) ) Addition and subtraction can be divided into four categories: join problems, separate problems, part-whole problems, and compare problems ([see Table 1](#) ). Within these four types of problems, most educators focus on addition and subtract when the result is unknown, this leads to the understanding that addition is “put together” and subtraction means to “take away”. This is a major misconception and limits the students’ understanding. One way to prevent development of this misunderstanding is to provide problem based story problems in which the students are attempting to solve not only the result but also the change, and the initial.

Students should not complete a multitude of problems within one class period, rather they should work in depth with as few as one problem that they can know and understand completely. Students do not need to know the names of the different types of problems but they should have experience in solving all of the different types. This lesson should not be looked at to be

completed in one session, these questions should be readdressed throughout this unit and continue throughout the mathematics curriculum across grade levels.

### **ESSENTIAL QUESTIONS**

- What happens when we join two quantities or take one from another?
- How can we find the total when we join two quantities?

### **MATERIALS**

- Paper
- Various Manipulatives (examples: counters, based ten blocks, arithmetic rack, etc.)
- Pencils and crayons
- Types of Problems (cut out)
- Twenty Game
- Dice
- Small counters

### **GROUPING**

Flexible grouping should be based on student needs. Depending on the story problem, this task could be solved with students working as a whole-class, small groups, or independently.

### **TASK DESCRIPTION, DEVELOPMENT AND DISCUSSION**

#### **Part I**

The teacher will tell a story similar to: Ten friends were playing outside together on a summer day. Some of the friends had to go home to eat lunch. Now there are six friends playing. How many friends went home to eat lunch?

After telling the story, suggested questions include:

- What is my story about?
- What happened first? What happened next?
- Were there more (or fewer) friends at beginning of the story or at the end of the story? How did you figure that out?
- How can we show/represent this? Can we act out the story?
- How many friends were there at the beginning of the story? (Feel free to let the students act out this situation if necessary)
- How many friends were taken away?
- How many friends were left at the end of the story? How do you know?

Continue questioning as needed until the students can answer the questions and understand what is happening in the story.

## **Part II**

Sample problems have been provided. Copy the problems, cut them out to give to students and/or flexible groups. Each set can be done within small groups or within centers/work stations. The sample word problems are designed to give a conceptual understanding of addition and subtraction of two numbers. Students should explore these problems using the CRA model. Refer to the CRA table on page 15 for explanation and questioning.

- C- Concrete: Using Manipulatives (acting out)
- R- Representational: Drawing Pictures
- A- Abstract: Creating Number Sentences

“In the classroom, this approach is a facilitating framework for students to create meaningful connections between concrete, representational, and abstract levels of thinking and understanding. Students’ learning starts out with visual, tangible, and kinesthetic experiences to establish basic understanding, and then students are able to extend their knowledge through pictorial representations (drawings, diagrams, or sketches) and then finally are able to move to the abstract level of thinking, where students are exclusively using mathematical symbols to represent and model problems.” Hauser, Jane. *Concrete-representational-abstract instructional approach*. Retrieved April 9, 2009, from the Access Center: Improving Outcomes for all Students K-8. Web site:

[http://www.k8accesscenter.org/training\\_resources/CRA\\_Instructional\\_Approach.asp](http://www.k8accesscenter.org/training_resources/CRA_Instructional_Approach.asp)

The problems listed below are examples from the four types of addition/subtraction problems. The numbers and topics of each problem can be adjusted based on the interest and ability of your students. All four types of problems should be focused in a variety of ways.

### *Join Problems:*

When joining two quantities, three different amounts are used: the initial amount, the change amount, and the result amount (or whole). (VDW)

### *Separate Problems:*

Within separate problems, your initial amount is the whole. This differs from a joining problem because within a joining problem your result is your whole. (VDW)

### *Part-Part-Whole Problems:*

Part-Part-Whole is the combining of two quantities to create a whole. The combination can take place physically, or it can be asked to be completed mentally.

### *Comparing Problems:*

Comparing problems do not focus on the operation, but rather the relationship between two quantities. This relationship can be stated or it can be implied by using terms of greater than or less than. (VDW)

**Georgia Department of Education**  
Georgia Standards of Excellence Framework  
*GSE Operations and Algebraic Thinking • Unit 3*

*Comment:* Teachers should expose students to a variety of separating problem types. Students do not need to know the names of the different types of problems but they should have experience in solving all of the different types.

### **Part III**

Students will work in pairs to play the *Twenty* game. Each player rolls a die, places that number of counters onto his/her ten frame, then announces the total number of counters on the ten frames. Next, the player records the number sentence onto the chart below. Both players will use the same recording sheet. Example: Player one rolls a 5. He places 5 counters onto his ten frame and writes the number sentence  $0+5=5$ . The 0 represents the number of counters on the ten frames before the roll, the 5 represents the number of counters added to the ten frames, and the 5 represents the total amount on the ten frames after the roll. Player 2 will then roll the die and do the same. On the next turn, player one rolls a 3. He place 3 counters on the tens frame and writes the number sentence  $5+3=8$ . The 5 represents the number of counters before the roll, the 3 represents the number of counters added to the ten frames, and the 8 represents the total amount on the ten frames after the roll. Play continues until a player fills both ten frames and reaches a sum of 20.

### **FORMATIVE ASSESSMENT QUESTIONS**

See suggested questioning located within task description and [CRA Table](#).

### **DIFFERENTIATION**

#### **Extension:**

- Allow students to work with numbers larger than 20 without regrouping.
- Ask students to create and solve their own story problems.

Note: Students typically create addition problems. Check students' problems to make sure they are creating subtraction problems too.

#### **Intervention**

- Allow students to work through the stages at a pace that is appropriate to their developmental level. This will provide students with the remediation they need to understand the concept of comparing numbers. Continue to allow them to work with manipulatives as much as needed. At times, partner them with students who are very articulate about their mathematical thinking so they can hear (through conversations) how these students have made sense of the problems.

# Twenty

Directions:

- Each player rolls a die, places that number of counters on his/her ten frame, then announces the total number of counters on the ten frames.
- Next, the player records the number sentence onto the chart below. Both players will use the same recording sheet. Example: Player one rolls a 5. He places 5 counters on his ten frame and writes the number sentence  $0+5=5$ . The 0 represents the number of counters on the ten frames before the roll, the 5 represents the number of counters added to the ten frames, and the 5 represents the total amount on the ten frames after the roll.
- Player 2 will then roll the die and do the same.
- On the next turn, player one rolls a 3. He place 3 counters on the tens frame and writes the number sentence  $5+3=8$ . The 5 represents the number of counters before the roll, the 3 represents the number of counters added to the ten frames, and the 8 represents the total amount on the ten frames after the roll.
- Play continues until a player fills both ten frames and reaches a sum of 20.

**Ten Frames for Twenty Game**





# Twenty

Player 1	Player 2
1.	
2.	
3.	
4.	
5.	
6.	
7.	
8.	
9.	
10.	

## **FAL: Caterpillars and Leaves**

See link below to access this assessment:

[Georgia Mathematics Educator Forum:  
Grades K-5 - K-5 Formative Assessment  
Lessons \(FAL\)](#)



## **Task 8**

### **CONSTRUCTING TASK: Shape Pounds**

*Approximately 2 days \*Adapted from NCTM's Navigating through Algebra P-2*

#### **STANDARDS FOR MATHEMATICAL CONTENT**

**MGSE1.OA.7** Understand the meaning of the equal sign, and determine if equations involving addition and subtraction are true or false. For example, which of the following equations are true and which are false?  $6 = 6$ ,  $7 = 8 - 1$ ,  $5 + 2 = 2 + 5$ ,  $4 + 1 = 5 + 2$ .

**MGSE1.OA.8** Determine the unknown whole number in an addition or subtraction equation relating to three whole numbers. For example, determine the unknown number that makes the equation true in each of the equations  $8 + ? = 11$ ,  $5 = \square - 3$ ,  $6 + 6 = \Delta$ .

#### **STANDARDS FOR MATHEMATICAL PRACTICE**

1. Make sense of problems and persevere in solving them. *Students discuss with classmates problem at hand and explaining an approach to use to solve the problem.*
2. Reason abstractly and quantitatively. *Students determine appropriate operation to use to solve problems.*
4. Model with mathematics.
6. Attend to precision.
7. Look for and make use of structure.
8. Look for and express regularity in repeated reasoning.

#### **BACKGROUND KNOWLEDGE/Common Misconceptions**

Many students think that the equals sign means that an operation must be performed on the numbers on the left and the result of this operation is written on the right. They think that the equal sign is like an arrow that means *becomes* and one number cannot be alone on the left. Students often ignore the equal sign in equations that are written in a nontraditional way. For instance, students find the incorrect value for the unknown in the equation  $9 = \Delta - 5$  by thinking  $9 - 5 = 4$ . It is important to provide equations with a single number on the left as in  $18 = 10 + 8$ . Showing pairs of equations such as  $11 = 7 + 4$  and  $7 + 4 = 11$  gives students experiences with the meaning of the equal sign as *is the same as* and equations with one number to the left.

## ESSENTIAL QUESTIONS

- What does the = sign mean?
- When is it appropriate to use the equal sign?

## MATERIALS

- Chart Paper
- Block Pounds Blackline Master

## GROUPING

Whole group/small group/individual

## TASK DESCRIPTION, DEVELOPMENT AND DISCUSSION

### **Part I**

Draw a picture of two balance scales on the board labeled A and B.

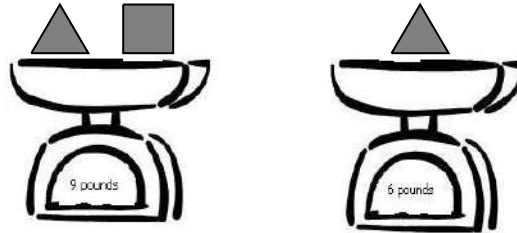

A

B

Inform the students that the weight listed on the scale is the weight of the blocks. Ask them the following questions:

- (pointing) What is the object shown on scale B?
- (pointing) What are the objects shown on scale A?
- What do you think that the weight of the triangle is? How do you know?
- What do you think the weight of the square is? How do you know?  
(The triangle is 6 pounds and the square is 9-6 pounds so it's 3)

Draw two additional scales on the board like the ones below.

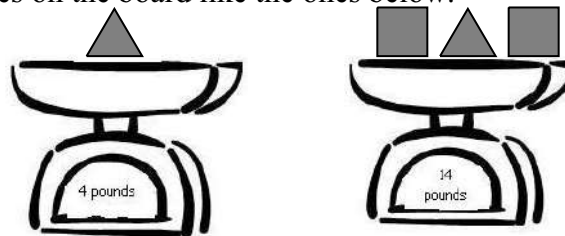

A

B

**Georgia Department of Education**  
Georgia Standards of Excellence Framework  
*GSE Operations and Algebraic Thinking • Unit 3*

Ask the following questions:

- What is the name of the object on scale A? How much does the triangle weigh?
- What are the names of the objects on scale B? How could you determine the weight of the squares ( $4 + 4 = 14$ )? *Do not introduce the writing of the equations using the until Part II. This idea should be developed through discussion and trial and error. It's important to work through the students thoughts as the discussion develops.*
- Do the two squares weigh the same? *At this point you will want to discuss that the squares will weigh the same, just as the  $\Delta$  weighs the same on both scales. This will also lead them to the discussion of double, in this case, 5 and 5.*

Students will be exploring variables as unknowns. They will be solving for the weights of the shapes using the information provided on the scales.

### **Part II**

Distribute a copy of the recording sheet “Shape Pounds”. Have students work in pairs to determine the weight of the shapes. Have them explain how they determined the weight of each shape. The weights of the shapes will increase in difficulty as the students move through the recording sheet.

### **Part III**

Work with students to develop equations representing the weight on the scales, using the same examples as in the opening,. For the first example, the equation would be  $9 = 6 + \square$ . It is important to reference their work in Part II and talk about the weights on both scales.

Ask the following questions:

- How did we know to put the 6 in the equation for scale A?
- Why did we add 6 to a square?
- What does the square represent?
- Why might we have put the 9 first?
- Can we write it like this  $6 + \square = 9$ ?

Do the same for the other scales and develop equations with the students. Ask students to revisit the recording sheet from Part 1. Ask them to write an equation for the scales.

Ask students to share their strategies for determining the weights of the objects and the equations that they wrote.

### **Part IV**

Students will work with a partner to play *Whose Sum is Larger?* Deal out an entire deck of playing cards out, so that the two players have an equal number of cards. Each player will turn over two playing cards from their stack. The player will add their two cards together. The player with the larger sum gets all four cards. If the two players have a tie, the players will turn over an additional card to add to their sum as a “tie breaker”. The player with the most cards wins, once players have gone through the entire deck,.

### **FORMATIVE ASSESSMENT QUESTIONS**

- What is the weight of the shape (pointing to a particular shape)? How did you determine the weight of the object?
- How can you write an equation/number sentence to represent the weight on the scale?

### **DIFFERENTIATION**

#### **Extension:**

- Students who are able to easily find the unknown and write equations using the variables, can balance the scales. For example, if one scale equals 9 and the other 14, how can we make them equal? What could we add to the 9 to make it fourteen?

#### **Intervention**

- Teacher can work with students in small groups using smaller numbers, with no more than two shapes, or use color tiles to represent pound amounts, allowing students to confirm quantities.

Name: \_\_\_\_\_

Date: \_\_\_\_\_

Shape Pounds

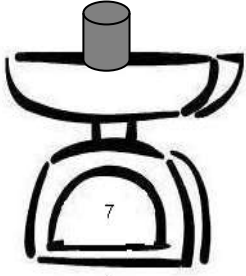
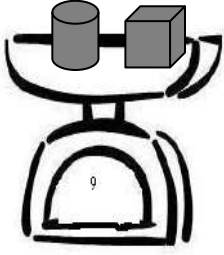
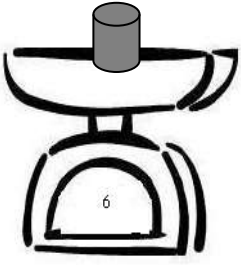
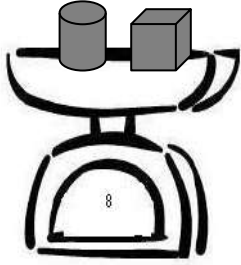
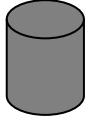
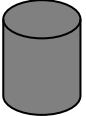
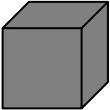
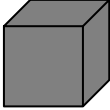
			
 = _____		 = _____	
 = _____		 = _____	

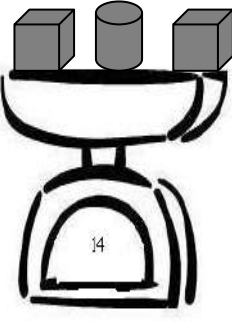
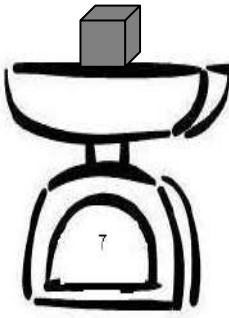
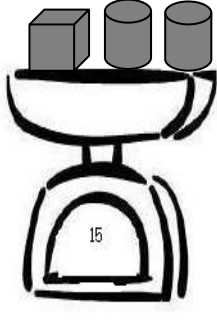
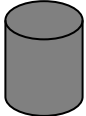
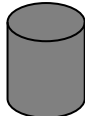
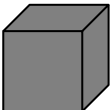
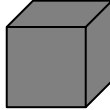
			
 = _____		 = _____	
 = _____		 = _____	

## **Whose Sum is Larger????**

**Materials Needed:**

Playing Cards

**Number of Players:**

Partners

**Directions:**

- Deal the entire deck of playing cards out, so that the two players have an equal number of cards.
- Each player will turn over two playing cards from their stack. The player will add their two cards together.
- The player with the larger sum gets all four cards.
- If the two players have a tie, the players will turn over an additional card to add to their sum as a “tie breaker”.
- Once players have gone through the entire deck, the player with the most cards wins.

**Variations:**

- Have students go through the deck multiple times.
- Have students play Whose Sum is Smaller.

## Task 9

### **SCAFFOLDING TASK: Fact Families to 10**

*Approximately 1-2 days*

*\* Adapted from Hands On Standards, Grades 1-2*

#### **STANDARDS FOR MATHEMATICAL CONTENT**

**MGSE1.OA.3.** Apply properties of operations as strategies to add and subtract.

Examples: If  $8 + 3 = 11$  is known, then  $3 + 8 = 11$  is also known. (Commutative property of addition.) To add  $2 + 6 + 4$ , the second two numbers can be added to make a ten, so  $2 + 6 + 4 = 2 + 10 = 12$ . (Associative property of addition.)

**MGSE1.OA.4.** Understand subtraction as an unknown-addend problem. For example, subtract  $10 - 8$  by finding the number that makes 10 when added to 8.

**MGSE1.OA.5.** Relate counting to addition and subtraction (e.g., by counting on 2 to add 2).

**MGSE1.OA.6**      **Add and subtract within 20.**

**a. Use strategies such as counting on; making ten (e.g.,  $8 + 6 = 8 + 2 + 4 = 10 + 4 = 14$ ); decomposing a number leading to a ten (e.g.,  $13 - 4 = 13 - 3 - 1 = 10 - 1 = 9$ ); using the relationship between addition and subtraction (e.g., knowing that  $8 + 4 = 12$ , one knows  $12 - 8 = 4$ ); and creating equivalent but easier or known sums (e.g., adding  $6 + 7$  by creating the known equivalent  $6 + 6 + 1 = 12 + 1 = 13$ ).**

**b. Fluently add and subtract within 10.**

#### **STANDARDS FOR MATHEMATICAL PRACTICE**

1. Make sense of problems and persevere in solving them. *Students discern which number families relate to one another.*
2. Reason abstractly and quantitatively.
4. Model with mathematics.
5. Use appropriate tools strategically.
6. Attend to precision.
7. Look for and make use of structure. *Students recognize patterns within number families.*
8. Look for and express regularity in repeated reasoning.

### **BACKGROUND KNOWLEDGE/COMMON MISCONCEPTIONS**

Fact families provide a method for children to compute fluently with whole numbers. Addition and subtraction fact families help children develop number sense as they see the relationship among numbers and between the operations. During grades 1 and 2, children should begin to shift from computing mentally to using pencil and paper. At the same time, mental math skills such as grouping and estimating continue to develop. Using fact families helps children develop these skills as they discern how numbers relate parts to a whole.

### **ESSENTIAL QUESTIONS**

- How can we show that addition and subtraction are related through fact families?
- What happens when we join two quantities or take one from another?
- How can we find what is left when we take one quantity from another?

### **MATERIALS**

- Connecting cubes
- Toy Boxes Recording Sheet
- Double Dice or Two dice
- Double Dice Addition/Subtraction Recording Sheet

### **GROUPING**

Depending on the story problem, this task could be solved with students working as a whole-class, small groups, or independently.

### **TASK DESCRIPTION, DEVELOPMENT AND DISCUSSION**

#### **Part I**

Introduce the problem:

*Mrs. Cloud's class is making boxes of toys to give to a preschool. Each box can have 4, 5, 6, 7, 8, 9, or 10 toys. Each box will have dolls and trucks. How many dolls and trucks can be in each box?*

Assign each student/group the number toys in the toy box. This is a perfect time to differentiate for students that would need to work numbers on their level. Then have them draw a picture of the dolls and the trucks within their toy box. At this time, have the students explain why they need that many dolls or that many trucks. This is a good time to assess if the students have an accurate number combination for their assigned number of toys in the toy box.



## **Part II**

During this task, the students will use the number of dolls and trucks that they created in the opening to build a fact family. The students will first build the family with connecting cubes and then write corresponding number sentences.

Ask children to make a train of connecting cubes using two different colors. The total number of cubes in the train should be the same as the number of toys in their toy box. One color should represent the number of dolls, and one color should represent the number of trucks. Then explain to the students that the dolls and trucks have switched, and they need to create a second train to represent the new number of each toy.

Help the children to create two addition sentences that describe their trains. Then, help them create two subtraction sentences that show what happens to the total if one color (or toy) is removed from the toy box. Lead children to discover that the same three numbers appear in all the number sentences, but do not explicitly tell them this. Once a student has discovered this pattern, explain to the class that this is called a fact family.

Encourage the students to find a different number of dolls and trucks that could still fit in their toy box.

## **Part III**

Students should play the Double Dice Addition Activity and Double Dice Subtraction Activity for further practice to build fluency.

## **FORMATIVE ASSESSMENT QUESTIONS**

- Do you see any similarities in your number sentences?
- Do you see any differences?
- Why do you think three numbers make up a fact family?

## **DIFFERENTIATION**

### **Extension**

- Create a fact family for a number sentence with an unknown.
- Allow students to choose the number of toys in their toy box, within their ability level.

### **Intervention**

- Begin with 4 toys total in the toy box.
- Use a different visual such as real dolls and trucks, or red and yellow counters.

Name: \_\_\_\_\_

Date: \_\_\_\_\_



### **Toy Boxes**

Mrs. Cloud's class is making boxes of toys to give to a preschool. Each box can have 4, 5, 6, 7, 8, 9, or 10 toys. Each box will have dolls and trucks. How many dolls and trucks can be in each box?



Name \_\_\_\_\_

## Double Dice Subtraction

Roll the double dice. Subtract the two numbers and record the number sentence. Make sure the greater number is first. If no double dice are available then use two 6-sided dice.

1. \_\_\_\_\_  $\underline{\quad}$  \_\_\_\_\_  $=$  \_\_\_\_\_

8. \_\_\_\_\_  $\underline{\quad}$  \_\_\_\_\_  $=$  \_\_\_\_\_

2. \_\_\_\_\_  $\underline{\quad}$  \_\_\_\_\_  $=$  \_\_\_\_\_

9. \_\_\_\_\_  $\underline{\quad}$  \_\_\_\_\_  $=$  \_\_\_\_\_

3. \_\_\_\_\_  $\underline{\quad}$  \_\_\_\_\_  $=$  \_\_\_\_\_

10. \_\_\_\_\_  $\underline{\quad}$  \_\_\_\_\_  $=$  \_\_\_\_\_

4. \_\_\_\_\_  $\underline{\quad}$  \_\_\_\_\_  $=$  \_\_\_\_\_

11. \_\_\_\_\_  $\underline{\quad}$  \_\_\_\_\_  $=$  \_\_\_\_\_

5. \_\_\_\_\_  $\underline{\quad}$  \_\_\_\_\_  $=$  \_\_\_\_\_

12. \_\_\_\_\_  $\underline{\quad}$  \_\_\_\_\_  $=$  \_\_\_\_\_

6. \_\_\_\_\_  $\underline{\quad}$  \_\_\_\_\_  $=$  \_\_\_\_\_

13. \_\_\_\_\_  $\underline{\quad}$  \_\_\_\_\_  $=$  \_\_\_\_\_

7. \_\_\_\_\_  $\underline{\quad}$  \_\_\_\_\_  $=$  \_\_\_\_\_

14. \_\_\_\_\_  $\underline{\quad}$  \_\_\_\_\_  $=$  \_\_\_\_\_

**Task 10**

**CONSTRUCTING TASK:** Developing Meaning by Using Story

Problems: Initial Unknown

*Approximately 2-3 days*

**STANDARDS FOR MATHEMATICAL CONTENT**

**MGSE1.OA.1.** Use addition and subtraction within 20 to solve word problems involving situations of adding to, taking from, putting together, taking apart, and comparing, with unknowns in all positions, e.g., by using objects, drawings, and equations with a symbol for the unknown number to represent the problem.

**STANDARDS FOR MATHEMATICAL PRACTICE**

1. Make sense of problems and persevere in solving them. *Students discuss all observations about the problems and how they solved it.*
2. Reason abstractly and quantitatively.
3. Construct viable arguments and critique the reasoning of others.
4. Model with mathematics.
5. Use appropriate tools strategically. *Students select and implement math tools to solve the problems.*
6. Attend to precision.
7. Look for and make use of structure.
8. Look for and express regularity in repeated reasoning.

**BACKGROUND KNOWLEDGE/COMMON MISCONCEPTIONS**

The goal for this lesson is to revisit real world problems, using the level of understanding (concrete, representational, or abstract) that each student needs. (see [CRA Table](#)) Addition and subtraction can be divided into four categories: join problems, separate problems, part-whole problems, and compare problems (see [Table 1](#)). Within these four types of problems, most educators focus on addition and subtract when the result is unknown, this leads to the understanding that addition is “put together” and subtraction means to “take away”. This is a major misconception and limits the students’ understanding. One way to prevent development of this misunderstanding is to provide problem based story problems in which the students are attempting to solve not only the result but also the change, and the initial.

Students should not complete a multitude of problems within one class period, rather they should work in depth with as few as one problem that they can know and understand completely. Students do not need to know the names of the different types of problems but they should have experience in solving all of the different types. This lesson should not be looked at to be

completed in one session, these questions should be readdressed throughout this unit and continue throughout the mathematics curriculum across grade levels.

### **ESSENTIAL QUESTIONS**

- What happens when we join two quantities or take one from another?
- How can we find the total when we join two quantities?

### **MATERIALS**

- Paper
- Various Manipulatives (examples: counters, based ten blocks, arithmetic rack, etc.)
- Pencils and crayons
- Types of Problems (cut out)
- Doubles Memory Game

### **GROUPING**

Flexible grouping based on student needs. Depending on the story problem, this task could be solved with students working as a whole-class, small groups, or independently.

### **TASK DESCRIPTION, DEVELOPMENT AND DISCUSSION**

#### **Part I**

The teacher will tell a story similar to: Some friends were playing outside together on a summer day. Two of the friends had to go home to eat lunch. Now, there are six friends playing. How many friends were outside playing together?

After telling the story, suggested questions include:

- What is my story about?
- What happened first?
- What happened next?
- Were there more (or fewer) friends at beginning of the story or at the end of the story?  
How did you figure that out?
- How can we show/represent this? Can we act out the story?
- How many friends were there at the beginning of the story? (Feel free to let the students act out this situation if necessary)
- How many friends were taken away?
- How many friends were left at the end of the story?
- How do you know?

Continue questioning as needed until the students can answer the questions and understand what is happening in the story.

## **Part II**

Sample problems have been provided. Copy the problems, cut them out to give to students and/or flexible groups. Each set can be done within small groups or within centers/work stations. The sample word problems are designed to give a conceptual understanding of addition and subtraction of two numbers. Students should explore these problems using the CRA model. [Refer to the CRA table for explanation and questioning.](#)

- C- Concrete: Using Manipulatives (acting out)
- R- Representational: Drawing Pictures
- A- Abstract: Creating Number Sentences

“In the classroom, this approach is a facilitating framework for students to create meaningful connections between concrete, representational, and abstract levels of thinking and understanding. Students’ learning starts out with visual, tangible, and kinesthetic experiences to establish basic understanding, and then students are able to extend their knowledge through pictorial representations (drawings, diagrams, or sketches) and then finally are able to move to the abstract level of thinking, where students are exclusively using mathematical symbols to represent and model problems.” Hauser, Jane. *Concrete-representational-abstract instructional approach*. Retrieved April 9, 2009, from the Access Center: Improving Outcomes for all Students K-8. Web site:  
[http://www.k8accesscenter.org/training\\_resources/CRA\\_Instructional\\_Approach.asp](http://www.k8accesscenter.org/training_resources/CRA_Instructional_Approach.asp)

The problems listed below are examples from the four types of addition/subtraction problems. The numbers and topics of each problem can be adjusted based on the interest and ability of your students. All four types of problems should be focused in a variety of ways.

### *Join Problems:*

When joining two quantities, three different amounts are used: the initial amount, the change amount, and the result amount (or whole). (VDW)

### *Separate Problems:*

Within separate problems, your initial amount is the whole. This differs from a joining problem because within a joining problem your result is your whole. (VDW)

### *Part-Part-Whole Problems:*

Part-Part-Whole is the combining of two quantities to create a whole. The combination can take place physically, or it can be asked to be completed mentally.

*Comparing Problems:*

Comparing problems do not focus on the operation, but rather the relationship between two quantities. This relationship can be stated or it can be implied by using terms of greater than or less than. (VDW)

**Part III**

Students will play *Sums of 10 Memory*. The purpose of this activity is for students to build their fluency of number combinations to ten. Students will play in groups of 2-4 and each group will need a deck of cards. This game is played like Memory. The cards are first spread out in an organized array with all cards face down. The first person turns over two cards, without moving them from original location. If the two cards showing create a number combination of ten, the player takes the pair and has another turn. If the cards do not create a number combination of ten, they turn the cards back over face down. The next player has a turn. The winner is the player with the most pairs.

**FORMATIVE ASSESSMENT QUESTIONS**

See suggested questioning located within task description and [CRA Table](#).

**DIFFERENTIATION**

**Extension:**

- Allow students to work with numbers larger than 20.
- Ask students to create and solve their own story problems.

Note: Students typically create addition problems. Check students' problems to make sure they are creating subtraction problems too.

**Intervention**

- Allow students to work through the stages at a pace that is appropriate to their developmental level. This will provide students with the remediation they need to understand the concept of comparing numbers. Continue to allow them to work with manipulatives as much as needed. At times, partner them with students who are very articulate about their mathematical thinking so they can hear (through conversations) how these students have made sense of the problems.
- For part II, allow students to use manipulatives or a number line to facilitate adding.

## Sums of Ten Memory

### Purpose:

The purpose of this activity is for students to build their fluency of number combinations to ten.

### How children will be organized:

Students will play in groups of 2-4

### What you need:

Playing cards:

- A: Aces= 1
- 2-10= their numerical value
- J-K (all face cards)= 10

### What to do:

This game is played like Memory. The cards are first spread out in an organized array with all cards face down. The first person turns over two cards, without moving them from original location. If the two cards showing create a number combination of ten, the player takes the pair and has another turn. If the cards do not create a number combination of ten, they turn the cards back over face down. The next player has a turn. The winner is the player with the most pairs.

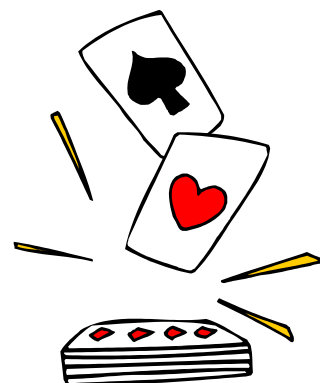



## Task 11

### **Practice Task: Domino Fact Families**

*Approximately 1 day (adapted from Mathwire.com)*

#### **STANDARDS FOR MATHEMATICAL CONTENT**

##### **MGSE1.OA.6**

##### **Add and subtract within 20.**

**a. Use strategies such as counting on; making ten (e.g.,  $8 + 6 = 8 + 2 + 4 = 10 + 4 = 14$ ); decomposing a number leading to a ten (e.g.,  $13 - 4 = 13 - 3 - 1 = 10 - 1 = 9$ ); using the relationship between addition and subtraction (e.g., knowing that  $8 + 4 = 12$ , one knows  $12 - 8 = 4$ ); and creating equivalent but easier or known sums (e.g., adding  $6 + 7$  by creating the known equivalent  $6 + 6 + 1 = 12 + 1 = 13$ ).**

**b. Fluently add and subtract within 10.**

#### **STANDARDS FOR MATHEMATICAL PRACTICE**

1. Make sense of problems and persevere in solving them. *Students discuss all observations about the problems and how they solved it.*
2. Reason abstractly and quantitatively.
4. Model with mathematics.
5. Use appropriate tools strategically. *Students select and implement appropriate tools to solve the problems.*
6. Attend to precision.
7. Look for and make use of structure.
8. Look for and express regularity in repeated reasoning. *Students subitize using dot cards.*

#### **BACKGROUND KNOWLEDGE/COMMON MISCONCEPTIONS**

Success in this task depends on students understanding that once they can recall a particular addition fact, they can use that fact to solve a variety of related addition and subtraction tasks. The set of related facts is called a family. Before this, students will see number facts as unrelated, and hence might feel burdened by how many facts there are to learn. The use of fact families can help students to see relationships between several addition and subtraction facts.

#### **ESSENTIAL QUESTIONS**

- How can we show that addition and subtraction are related through fact families?
- What happens when we join two quantities or take one from another?

## **MATERIALS**

- One bag of dominos per student (approximately 8 within each bag), or domino cut-outs (see K units for domino masters)
- Domino Fact Family Recording Sheet
- Ten Wins!
- Dice
- Counters

## **GROUPING**

Individual

## **TASK DESCRIPTION, DEVELOPMENT, AND DISCUSSION**

### **Part I**

Gather students to a common area. Draw several demonstration dominos on the board. You can also make large demonstration dominos by cutting a piece of poster paper in half and drawing dots on either side. Ask students to look at both halves of the domino and tell how many dots are in each square. Suggested questions include:

- What is the sum if you add the dots in each square?
- Will the sum change if I flip the domino (180 degree turn)? Why do you think this? (*Special Note: This is not about students understanding degrees and angles. It is included for teachers to identify the specific way to flip the domino.*)
- Is there another way we could write the addition sentence and still get the same sum?
- What would the difference be if you subtracted the number of dots in one of the squares from the sum?
- What type of relationship are you noticing?
- What are the number sentences in the fact family for this domino?

### **Part II**

Allow children to work independently to record the fact families that their dominos show. They will need to draw each domino and label it with their fact family using the recording sheet. Observe the counting strategies that the children utilize. Notice if they are counting on, counting each individual dot, or recalling the answers because they know their addition and subtraction facts. (*Note: Students are only being exposed to the concepts of vertical and horizontal. It is not the focus of the task, but teachers are encouraged to use the terms in vocabulary. Students are not responsible for this yet.*)

Allow several students to share their work. Allow students to discuss how they determined the number sentences in their fact family and the strategies they used to create these number

sentences. Allow time for the student who is sharing to answer questions, receive compliments, and listen to suggestions from the audience.

### **Part III**

Students will play, *Ten Wins!* with a partner. Each player will need 10 counters of one color. Player one will roll the dice and add the two numbers to find the sum. Cover the sum with their designated color counter. Player two will roll the dice and add the two numbers to find the sum. They will also cover the sum with their designated color counter. If a space is already covered by the opponents counter, then a player may steal that spot. Example: Player one has a blue counter on the number 9. Player two rolls a 5 and 4. Player two may remove the blue counter and place their color counter on that space. The first player to use all ten counters on the game board wins!

### **FORMATIVE ASSESSMENT QUESTIONS**

- How many dots are on the left side of your domino (looking at it horizontally)?
- How many dots are on the top of your domino (looking at it vertically)
- How many dots are on the right side of your domino (looking at it horizontally)?
- How many dots are on the bottom of your domino (looking at it vertically)?
- What is the sum if you add the dots in each of your domino squares?
- Is there another way you could write the addition sentence and still get the same sum?
- What would the difference be if you subtracted the number of dots in one of the squares from the sum?
- What are the numbers in this fact family?
- What type of relationship are you noticing?
- What are the number sentences in the fact family for this domino?
- How are you determining the fact families for each of your dominoes?
- Why is important to know fact families?

### **DIFFERENTIATION**

#### **Extension**

- Allow students to create their own fact families with larger numbers.

#### **Intervention**

- Give students note cards that have an addition or subtraction number sentence written on each card. Have students group the cards into fact families. Once they get the hang of this, give them three of the four number sentences and they have to figure out the one that is missing. As they get better with the game start decreasing the number of sentences you give them. Once they can tell you three of the sentences when you have only given them one, change the game. You give them all the number sentences in the family and they have to tell you who the individual family members are.

**Georgia Department of Education**  
Georgia Standards of Excellence Framework  
*GSE Operations and Algebraic Thinking • Unit 3*

**Technology Connection**

- This Smart Board activity provides additional practice with adding the pips on a domino.  
<http://exchange.smarttech.com/details.html?id=48909ccd-c54a-4281-aaea-91faf0f33354>

**Name:** \_\_\_\_\_ **Date:** \_\_\_\_\_

## Domino Fact Family Recording Sheet

<div style="border: 1px solid black; width: 100%; height: 80px; margin-bottom: 10px;"></div> $___ + ___ = ___$ $___ + ___ = ___$ $___ - ___ = ___$ $___ - ___ = ___$	<div style="border: 1px solid black; width: 100%; height: 80px; margin-bottom: 10px;"></div> $___ + ___ = ___$ $___ + ___ = ___$ $___ - ___ = ___$ $___ - ___ = ___$	<div style="border: 1px solid black; width: 100%; height: 80px; margin-bottom: 10px;"></div> $___ + ___ = ___$ $___ + ___ = ___$ $___ - ___ = ___$ $___ - ___ = ___$	<div style="border: 1px solid black; width: 100%; height: 80px; margin-bottom: 10px;"></div> $___ + ___ = ___$ $___ + ___ = ___$ $___ - ___ = ___$ $___ - ___ = ___$
<div style="border: 1px solid black; width: 100%; height: 80px; margin-bottom: 10px;"></div> $___ + ___ = ___$ $___ + ___ = ___$ $___ - ___ = ___$ $___ - ___ = ___$	<div style="border: 1px solid black; width: 100%; height: 80px; margin-bottom: 10px;"></div> $___ + ___ = ___$ $___ + ___ = ___$ $___ - ___ = ___$ $___ - ___ = ___$	<div style="border: 1px solid black; width: 100%; height: 80px; margin-bottom: 10px;"></div> $___ + ___ = ___$ $___ + ___ = ___$ $___ - ___ = ___$ $___ - ___ = ___$	<div style="border: 1px solid black; width: 100%; height: 80px; margin-bottom: 10px;"></div> $___ + ___ = ___$ $___ + ___ = ___$ $___ - ___ = ___$ $___ - ___ = ___$



# Ten Wins!

**Directions:** Ten Wins! is a partner game. Each player will need 10 counters of one color. Player one will roll the dice and add the two numbers to find the sum. Cover the sum with their designated color counter. Player two will roll the dice and add the two numbers to find the sum. They will also cover the sum with their designated color counter. If a space is already covered by the opponent's counter then a player may steal that spot. Example: Player one has a blue counter on the number 9. Player two rolls a 5 and 4. Player two may remove the blue counter and place their color counter on that space. The first player to use all ten counters on the game board wins!

<b>7</b>	<b>3</b>	<b>6</b>	<b>2</b>	<b>4</b>
<b>6</b>	<b>10</b>	<b>3</b>	<b>10</b>	<b>9</b>
<b>11</b>	<b>7</b>	<b>9</b>	<b>4</b>	<b>7</b>
<b>4</b>	<b>12</b>	<b>7</b>	<b>9</b>	<b>5</b>
<b>8</b>	<b>6</b>	<b>5</b>	<b>8</b>	<b>12</b>

## Task 12

### **Practice Task: Candy**

*Approximately 1 day*

#### **STANDARDS FOR MATHEMATICAL CONTENT**

**MGSE1.MD.4.** Organize, represent, and interpret data with up to three categories; ask and answer questions about the total number of data points, how many in each category, and how many more or less are in one category than in another.

**MGSE1.OA.5.** Relate counting to addition and subtraction (e.g., by counting on 2 to add 2).

#### **STANDARDS FOR MATHEMATICAL PRACTICE**

1. Make sense of problems and persevere in solving them.
2. Reason abstractly and quantitatively.
3. Construct viable arguments and critique the reasoning of others.
4. Model with mathematics. *Students construct graphs to model data collected.*
5. Use appropriate tools strategically.
6. Attend to precision. *Students make observations based on the data collected in the survey.*
7. Look for and make use of structure.
8. Look for and express regularity in repeated reasoning.

#### **BACKGROUND KNOWLEDGE/COMMON MISCONCEPTIONS**

This standard calls for students to work with categorical data by organizing, representing and interpreting data. Students should have experiences posing a question with 3 possible responses and then work with the data that they collect. For example:

Students pose a question and the 3 possible responses: *Which is your favorite flavor of ice cream? Chocolate, vanilla or strawberry?* Students collect their data by using tallies or another way of keeping track. Students organize their data by totaling each category in a chart or table. ***Picture and bar graphs are introduced in 2<sup>nd</sup> Grade.***

<b>What is your favorite flavor of ice cream?</b>	
Chocolate	12
Vanilla	5
Strawberry	6

## **ESSENTIAL QUESTIONS**

- How do tables help you organize your thinking?

## **MATERIALS**

- Snack size packs of Skittles or M&Ms, (one bag for each pair of students or small group) (may substitute buttons, or color tiles)
- Paper and pencils

## **GROUPING**

Whole class/small group/partners

## **TASK DESCRIPTION, DEVELOPMENT AND DISCUSSION**

### **Part I**

Let students know that they will be collecting data on the different colors in the bag of M&Ms/Skittles. Ask the students to name the colors that they may find in the bag. Write the list on the board. Take a survey asking the class to vote for their favorite color. Display the data in a table using numbers or tallies. Ask the students to identify the 3 colors that were liked the best. Pose the questions, “Which color do the most students like?” “What is the second and third favorite in the class?” After each question have them explain how they knew that it was a favorite.

### **Part II**

Students will be organizing data into three categories (the three favorite colors chosen in the opening). They will use the snack size bags to record the amount of each color that they bag contains.

Provide each pair of students with a snack size bag of M&Ms or Skittles. Instruct students to open the bag and pull the colors out that were decided in the opening (the three favorite colors). Students will count and record the amount of each of the three colors in a table.

Pose the following questions to the students:

- Which color has the most? How do you know?
- Which color has the least? How do you know?
- How can you figure out if a color has more or less?
- How many more of color A than of color B or C? How do you know?
- Do you think that all of the bags will have the same amount of each color? Why?
- How many of A, B, and C do you have?
- Is it more or less than 20? How many more would you need to make 20? How do you know?



Have students ask classmates these same questions.

### **FORMATIVE ASSESSMENT QUESTIONS**

See questions suggested within task description.

### **DIFFERENTIATION**

#### **Extension:**

- Allow students to create a table that represents all of the colors in the bag. Pose the same questions.
- Ask students to formulate questions about their tables to ask other classmates. Encourage them to write higher level comparison questions.

#### **Intervention**

- Allow students to place the candies on ten frames when determining the sums and differences.

**Task 13**

**Culminating Task: Atlanta Zoo**

*Approximately 1 day*

**STANDARDS FOR MATHEMATICAL CONTENT**

**MGSE1.MD.4.** Organize, represent, and interpret data with up to three categories; ask and answer questions about the total number of data points, how many in each category, and how many more or less are in one category than in another.

**MGSE1.OA.1.** Use addition and subtraction within 20 to solve word problems involving situations of adding to, taking from, putting together, taking apart, and comparing, with unknowns in all positions, e.g., by using objects, drawings, and equations with a symbol for the unknown number to represent the problem.

**MGSE1.OA.5.** Relate counting to addition and subtraction (e.g., by counting on 2 to add 2).

**STANDARDS FOR MATHEMATICAL PRACTICE**

1. Make sense of problems and persevere in solving them.
2. Reason abstractly and quantitatively.
3. Construct viable arguments and critique the reasoning of others.
4. Model with mathematics. *Students construct a graph to model data collected.*
5. Use appropriate tools strategically.
6. Attend to precision. *Students make observations based on the data collected in the survey.*
7. Look for and make use of structure.
8. Look for and express regularity in repeated reasoning.

**BACKGROUND KNOWLEDGE/COMMON MISCONCEPTIONS**

In order to complete this culminating activity, students should have had prior experiences reading and creating tally charts and tables. They should have also had opportunities to work through several types of problem solving activities using the C-R-A model and working with three addends.

**ESSENTIAL QUESTIONS**

- How do tables help us organize our thinking?
- How are the properties of addition useful when problem solving?

**MATERIALS**

- Paper and pencils

**Georgia Department of Education**  
Georgia Standards of Excellence Framework  
*GSE Operations and Algebraic Thinking • Unit 3*

- Manipulatives such as linking cubes, or counters
- *Animals on Board* by Stuart J. Murphy or a similar animal book
- Atlanta Zoo Recording Sheet

## **GROUPING**

Individual

## **TASK DESCRIPTION, DEVELOPMENT AND DISCUSSION**

### **Part I**

Read *Animals on Board* by Stuart J. Murphy or a similar animal book. After reading the book ask students the following questions:

- What if we only knew the total number of Animals?
- How could we determine how many of each kind?

Allow them to share and model their thoughts.

### **Part II**

Students will be using and creating tables/tally charts, as well as working with a sum and discovering the various addends to solve the problem. The students will come up with a variety of solutions. They will be demonstrating their ability to reason through a problem.

The Atlanta Zoo will be receiving 16 new animals. Some are zebras, some are chimpanzees, and some are giraffes. How many of each kind could they be receiving? Find as many combinations as you can. Use data tables to record your responses. Answers will vary.

## **FORMATIVE ASSESSMENT QUESTIONS**

- Is there another combination for the zoo animals?
- Have you found all of the possibilities? How do you know?
- How many more of animal A do you have in this table than animal B or C?
- How did you know the total of each animal?
- How does creating a table help you determine your addends?

**DIFFERENTIATION**

**Extension**

- Students could be given a greater sum, or amount of animals.
- Write and solve their own story problem with three or more addends.

**Intervention**

- Provide manipulatives or paper cut outs of animals
- Students can use only two types of animals.
- They can act out the scenario in a one-on-one interview with the teacher.

Name: \_\_\_\_\_

Date: \_\_\_\_\_

## The Atlanta Zoo



The Atlanta Zoo will be receiving 18 new animals. Some are zebras, some are chimpanzees, and some are giraffes. How many of each kind could they be receiving? Find as many combinations as you can. Use data tables to record your responses.