

1. For which of the following motions of an object must the acceleration always be zero?

- I. Any motion in a straight line
- II. Simple harmonic motion
- III. Any motion in a circle

- (A) I only
- (B) II only
- (C) III that
- (D) Either I or III, but not II
- (E) None of these motions guarantees zero acceleration.

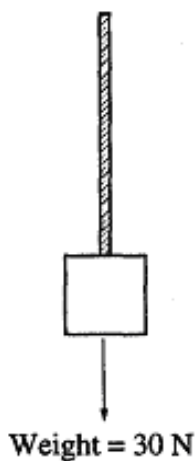

2. A rope of negligible mass supports a block that weighs 30 N, as shown above. The breaking strength of the rope is 50 N. The largest acceleration that can be given to the block by pulling up on it with the rope without breaking the rope is most nearly

- (A)  $6 \text{ m/s}^2$
- (B)  $6.7 \text{ m/s}^2$
- (C)  $10 \text{ m/s}^2$
- (D)  $15 \text{ m/s}^2$
- (E)  $16.7 \text{ m/s}^2$

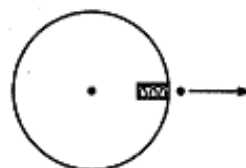

Top View

3. A compressed spring mounted on a disk can project a small ball. When the disk is not rotating as shown in the view above, the ball moves radially outward. The disk then rotates in a counterclockwise direction as seen from above, and the ball is projected outward at the instant the disk is in the position shown above.

Which of the following best shows the subsequent path of the ball relative to the ground?

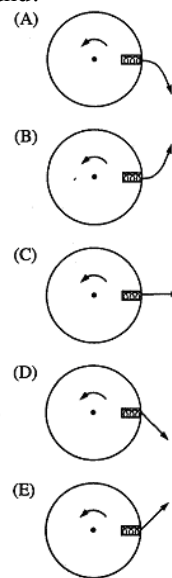

4. A ball is thrown straight up in the air. When the ball reaches its highest point, which of the following is true?

- (A) It is in equilibrium.
- (B) It has zero acceleration
- (C) It has maximum momentum.
- (D) It has maximum kinetic energy.
- (E) None of the above

5. The figure shows an object of mass 0.4 kg that is suspended from a scale and submerged in a liquid. If the reading on the scale is 3 N, then the buoyant force that the fluid exerts on the object is most nearly

- (A) 1.3 N  
 (B) 1.0 N  
 (C) 0.75 N  
 (D) 0.33 N  
 (E) 0.25 N

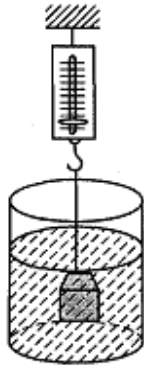

7. If both spheres have the same period of oscillation, which of the following is an expression for the spring constant?

- (A)  $\frac{\ell}{m_1 g}$   
 (B)  $\frac{g}{m_2 \ell}$   
 (C)  $\frac{m_1 \ell}{g}$   
 (D)  $\frac{m_2 g}{\ell}$   
 (E)  $\frac{m_1 g}{\ell}$

Questions 6-7

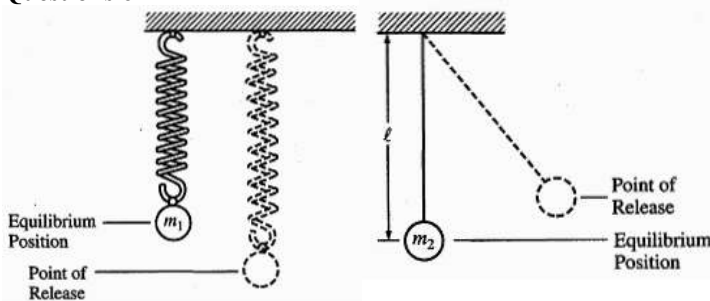

A sphere of mass  $m_1$ , which is attached to a spring, is displaced downward from its equilibrium position as shown above left and released from rest. A sphere of mass  $m_2$ , which is suspended from a string of length  $l$ , is displaced to the right as shown above right and released from rest so that it swings as a simple pendulum with small amplitude. Assume that both spheres undergo simple harmonic motion.

6. Which of the following is true for both spheres?
- (A) The maximum kinetic energy is attained as the sphere passes through its equilibrium position.  
 (B) The maximum kinetic energy is attained as the sphere reaches its point of release.  
 (C) The minimum gravitational potential energy is attained as the sphere passes through its equilibrium position.  
 (D) The maximum gravitational potential energy is attained when the sphere reaches its point of release.  
 (E) The maximum total energy is attained only as the sphere passes through its equilibrium position.

8. A block attached to the lower end of a vertical spring oscillates up and down. If the spring obeys Hooke's law, the period of oscillation depends on which of the following?

- I. Mass of the block  
 II. Amplitude of the oscillation  
 III. Force constant of the spring

- (A) I only  
 (B) II only  
 (C) III only  
 (D) I and II  
 (E) I and III

9. An empty sled of mass  $M$  moves without friction across a frozen pond at speed  $v_o$ . Two objects are dropped vertically into the sled one at a time: first an object of mass  $m$  and then an object of mass  $2m$ . Afterward the sled moves with speed  $v_f$ . What would be the final speed of the sled if the objects were dropped into it in reverse order?

- (A)  $v_f / 3$   
 (B)  $v_f / 2$   
 (C)  $v_f$   
 (D)  $2 v_f$   
 (E)  $3 v_f$

10. A new planet is discovered that has twice the Earth's mass and twice the Earth's radius. On the surface of this new planet, a person who weighs 500 N on Earth would experience a gravitational force of

- (A) 125 N  
 (B) 250 N  
 (C) 500 N  
 (D) 1000 N  
 (E) 2000 N

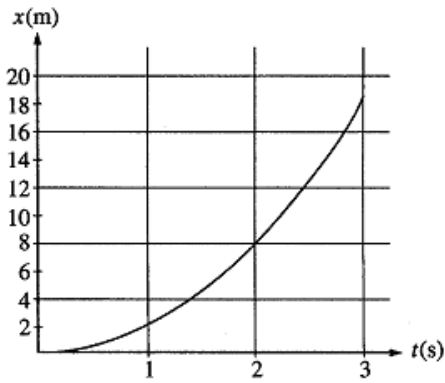

11. The graph above represents position  $x$  versus time  $t$  for an object being acted on by a constant force. The average speed during the interval between 1 s and 2 s is most nearly

- (A) 2 m/s
- (B) 4 m/s
- (C) 5 m/s
- (D) 6 m/s
- (E) 8 m/s

12. Two blocks of steel, the first of mass 1 kg and the second of mass 2 kg are in thermal equilibrium with a third block of aluminum of mass 2 kg that has a temperature of 400 K. What are the respective temperatures of the first and second steel blocks?

- (A) 400 K and 200 K
- (B) 200K and 400K
- (C) 400 K and 400 K
- (D) 800 K and 400 K
- (E) None of the above

13. An ideal gas may be taken from one state to another state with a different pressure, volume and temperature along several different paths. Quantities that will always be the same for this process, regardless of which path is taken, include which of the following?

- I. The change in internal energy of the gas
- II. The heat exchanged between the gas and its surroundings
- III. The work done by the gas

- (A) I only
- (B) II only
- (C) I and III only
- (D) II and III only
- (E) I, II, and III

14. Two parallel wires, each carrying a current  $I$ , repel each other with a force  $F$ . If both currents are doubled, the force of repulsion is

- (A)  $2F$
- (B)  $2\sqrt{F}$
- (C)  $4F$
- (D)  $4\sqrt{F}$
- (E)  $8F$

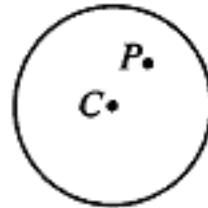

15. The hollow metal sphere shown above is positively charged. Point  $C$  is the center of the sphere and point  $P$  is any other point within the sphere. Which of the following is true of the electric field at these points?

- (A) It is zero at both points.
- (B) It is zero at  $C$  but at  $P$  it is not zero and is directed inward.
- (C) It is zero at  $C$  but at  $P$  it is not zero and is directed outward.
- (D) It is zero at  $P$  but at  $C$  it is not zero.
- (E) It is not zero at either point.

16. The total capacitance of several capacitors in parallel is the sum of the individual capacitances for which of the following reasons?

- (A) The charge on each capacitor depends on its capacitance, but the potential difference across each is the same.
- (B) The charge is the same on each capacitor, but the potential difference across each capacitor depends on its capacitance.
- (C) Equivalent capacitance is always greater than the largest capacitance.
- (D) Capacitors in a circuit always combine like resistors in series.
- (E) The parallel combination increases the effective separation of the plates.

17. A wire of length  $L$  and radius  $r$  has a resistance  $R$ . What is the resistance of a second wire made from the same material that has a length  $L/2$  and a radius  $r/2$ ?

- (A)  $4R$
- (B)  $2R$
- (C)  $R$
- (D)  $R/2$
- (E)  $R/4$

18. The operating efficiency of a 0.5 A, 120 V electric motor that lifts a 9 kg mass against gravity at an average velocity of 0.5 m/s is most nearly

- (A) 7 %
- (B) 13 %
- (C) 25 %
- (D) 53 %
- (E) 75 %

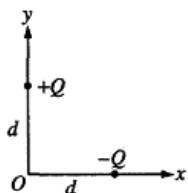

**Questions 19-20**

Charges  $-Q$  and  $+Q$  are located on the  $x$ - and  $y$ - axes, respectively, each at a distance  $d$  from the origin  $O$ , as shown to the left.

19. What is the direction of the electric field at the origin  $O$ ?

- (A)
- (B)
- (C)
- (D)
- (E)

20. What is the magnitude of the electric field at the origin  $O$ ?

- (A)  $\frac{kQ}{2d^2}$
- (B)  $\frac{kQ}{\sqrt{2}d^2}$
- (C)  $\frac{kQ}{d^2}$
- (D)  $\frac{\sqrt{2}kQ}{d^2}$
- (E)  $\frac{2kQ}{d^2}$

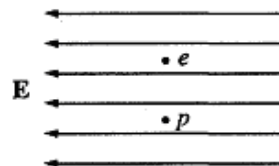

21. An electron  $e$  and a proton  $p$  are simultaneously released from rest in a uniform electric field  $E$ , as shown above.

Assume that the particles are sufficiently far apart so that the only force acting on each particle after it is released is that due to the electric field. At a later time when the particles are still in the field, the electron and the proton will have the same

- (A) direction of motion
- (B) speed
- (C) displacement
- (D) magnitude of acceleration
- (E) magnitude of force acting on them

22. A square steel plate with sides of length 1.00 m has a hole in its center 0.100 m in diameter. If the entire plate is heated to such a temperature that its sides become 1.01 m long, the diameter of the hole will be

- (A) 0.090 m
- (B) 0.099 m
- (C) 0.100 m
- (D) 0.101 m
- (E) 0.110 m

23. Which of the following will occur if the average speed of the gas molecules in a closed rigid container is increased?

- (A) The density of the gas will decrease.
- (B) The density of the gas will increase.
- (C) The pressure of the gas will increase.
- (D) The pressure of the gas will decrease.
- (E) The temperature of the gas will decrease.

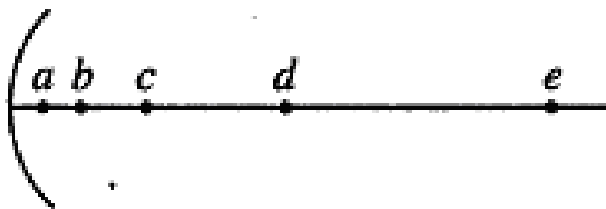

24. The spherical mirror shown above has a center of curvature at point  $c$ . Which point is nearest to the focal point?

- (A)  $a$
- (B)  $b$
- (C)  $c$
- (D)  $d$
- (E)  $e$

25. The frequencies of the first two overtones (second and third harmonics) of a vibrating string are  $f$  and  $3f/2$ . What is the fundamental frequency of this string?

- (A)  $f/3$
- (B)  $f/2$
- (C)  $f$
- (D)  $2f$
- (E)  $3f$

26. An object is placed in front of a converging thin lens at a distance from the center of the lens equal to half the focal length. Compared to the object, the image is

- (A) upright and larger
- (B) upright and smaller
- (C) inverted and larger
- (D) inverted and smaller
- (E) inverted and the same size

27. A radio station broadcasts on a carrier frequency of 100 MHz. The wavelength of this radio wave is most nearly

- (A)  $3.0 \times 10^{-3}$  m
- (B) 1.0 m
- (C) 3.0 m
- (D) 3.3 m
- (E)  $3.0 \times 10^6$  m

28. Which of the following is characteristic of both sound and light waves?

- (A) They are longitudinal waves.
- (B) They are transverse waves
- (C) They travel with the same velocity.
- (D) They can be easily polarized.
- (E) They give rise to interference effects.

Questions 29-30

A student obtains data on the magnitude of force applied to an object as a function of time and displays the data on the graph above.

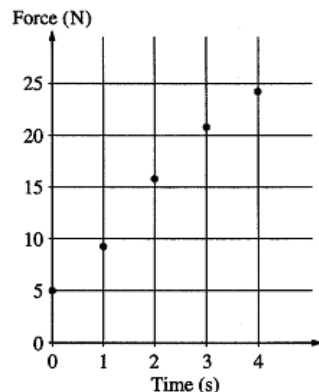

29. The slope of the “best fit” straight line is most nearly

- (A) 3 N/s
- (B) 6 N/s
- (C) 7 N/s
- (D) 8 N/s
- (E) 10 N/s

30. The increase in the momentum of the object between  $t = 0$  s and  $t = 4$  s is most nearly

- (A) 40 Ns
- (B) 50 Ns
- (C) 60 Ns
- (D) 80 Ns
- (E) 100 Ns

31. How does an air mattress protect a stunt person landing on the ground after a stunt?

- (A) It reduces the kinetic energy loss of the stunt person.
- (B) It reduces the momentum change of the stunt person.
- (C) It increases the momentum change of the stunt person
- (D) It shortens the stopping time of the stunt person and increases the force applied during the landing.
- (E) It lengthens the stopping time of the stunt person and reduces the force applied during the landing

Questions 32-33

A horizontal uniform board of weight 125 N and length 4 m is supported by vertical chains at each end. A person weighing 500 N is sitting on the board. The tension in the right chain is 250 N.

32. What is the tension in the left chain?

- (A) 250 N
- (B) 375 N
- (C) 500 N
- (D) 625 N
- (E) 875 N

33. How far from the left end of the board is the person sitting?

- (A) 0.4 m
- (B) 1.5 m
- (C) 2 m
- (D) 2.5 m
- (E) 3 m

Questions 34-35 relate to the photoelectric effect. For each question, choose an answer from the following graphs.

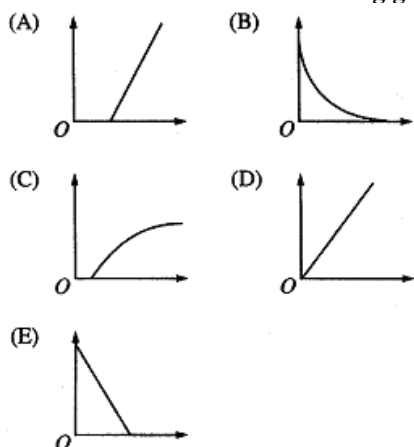

34. Which graph shows the maximum kinetic energy of the emitted electrons *versus* the frequency of the light?

- (A) A (B) B (C) C (D) D (E) E

35. Which graph shows the total photoelectric current *versus* the intensity of the light for a fixed frequency above the cutoff frequency?

- (A) A (B) B (C) C (D) D (E) E

36. Which of the following statements about the number of protons  $Z$  and the number of neutrons  $N$  in stable nuclei is true?

- (A) All stable nuclei have  $Z = N$ .  
 (B) Only heavy stable nuclei have  $Z = N$ .  
 (C) Heavy stable nuclei tend to have  $Z < N$ .  
 (D) All light stable nuclei have  $Z < N$ .  
 (E) All light stable nuclei have  $Z > N$ .

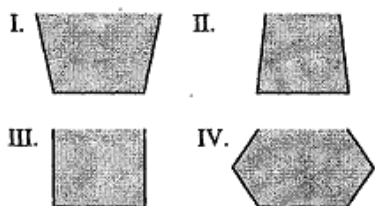

37. Each of the beakers shown above is filled to the same depth  $h$  with liquid of density  $p$ . The area  $A$  of the flat bottom is the same for each beaker. Which of the following ranks the beakers according to the net downward force exerted by the liquid on the flat bottom, from greatest to least force?

- (A) I, III, II, IV  
 (B) I, IV, III, II  
 (C) II, III, IV, I  
 (D) IV, III, I, II  
 (E) None of the above; the force on each is the same.

38. A T-shaped tube with a constriction is inserted in a vessel containing a liquid, as shown above. What happens if air is blown through the tube from the left, as shown by the arrow in the diagram?

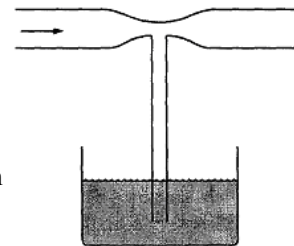

- (A) The liquid level in the tube rises to a level above the surface of the liquid surrounding the tube.  
 (B) The liquid level in the tube falls below the level of the surrounding liquid.  
 (C) The liquid level in the tube remains where it is.  
 (D) The air bubbles out at the bottom of the tube.  
 (E) Any of the above depending on how hard the air flows.

39. A spring scale calibrated in kilograms is used to determine the density of a rock specimen. The reading on the spring scale is 0.45 kg when the specimen is suspended in air and 0.36 kg when the specimen is fully submerged in water. If the density of water is  $1000 \text{ kg/m}^3$ , the density of the rock specimen is

- (A)  $2.0 \times 10^2 \text{ kg/m}^3$   
 (B)  $8.0 \times 10^2 \text{ kg/m}^3$   
 (C)  $1.25 \times 10^3 \text{ kg/m}^3$   
 (D)  $4.0 \times 10^3 \text{ kg/m}^3$   
 (E)  $5.0 \times 10^3 \text{ kg/m}^3$

40. Two objects, A and B, initially at rest, are "exploded" apart by the release of a coiled spring that was compressed between them. As they move apart, the velocity of object A is 5 m/s and the velocity of object B is -2 m/s. The ratio of the mass of object A to the mass of object B,  $m_A/m_B$ , is

- (A) 4/25  
 (B) 2/5  
 (C) 1/1  
 (D) 5/2  
 (E) 25/4

41. The cart of mass 10 kg shown above moves without frictional loss on a level table. A 10 N force pulls on the cart horizontally to the right. At the same time, a 30 N force at an angle of  $60^\circ$  above the horizontal pulls on the cart to the left. What is the magnitude of the horizontal acceleration of the cart?

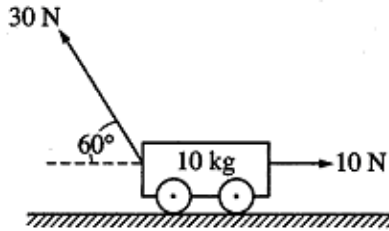

- (A)  $0.5 \text{ m/s}^2$
- (B)  $1.6 \text{ m/s}^2$
- (C)  $2.0 \text{ m/s}^2$
- (D)  $2.5 \text{ m/s}^2$
- (E)  $2.6 \text{ m/s}^2$

42. A child has a toy tied to the end of a string and whirls the toy at constant speed in a horizontal circular path of radius  $R$ . The toy completes each revolution of its motion in a time period  $T$ . What is the magnitude of the acceleration of the toy?

- (A) Zero
- (B)  $4\pi^2 R / T^2$
- (C)  $\pi R / T^2$
- (D)  $g$
- (E)  $2\pi g$

43. A simple pendulum and a mass hanging on a spring both have a period of 1 second when set into small oscillatory motion on Earth. They are taken to Planet X, which has the same diameter as Earth but twice the mass. Which of the following statements is true about the periods of the two objects on Planet X compared to their periods on earth?

- (A) Both are shorter.
- (B) Both are the same.
- (C) Both are longer.
- (D) The period of the mass on the spring is shorter; that of the pendulum is the same.
- (E) The period of the pendulum is shorter; that of the mass on the spring is the same.

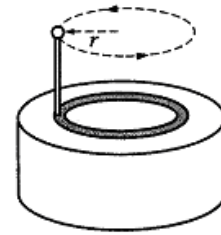

44. A steel ball supported by a stick rotates in a circle of radius  $r$ , shown above. The direction of the net force acting on the ball when it is in the position shown is indicated by which of the following

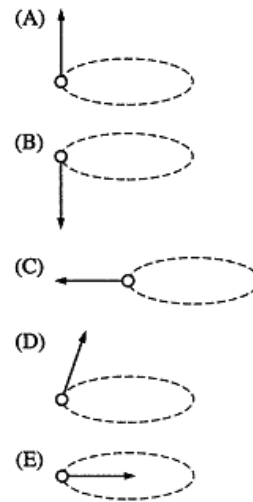

Questions 45-46

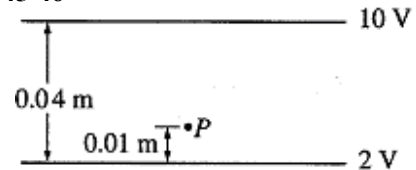

Two large, flat, parallel conducting plates are 0.04 m apart, as shown above. The lower plate is at a potential of 2 V with respect to ground. The upper plate is at a potential of 10 V with respect to ground. Point  $P$  is located 0.01 m above the lower plate

45. The electric potential at point  $P$  is

- (A) 10 V
- (B) 8 V
- (C) 6 V
- (D) 4 V
- (E) 2 V

46. The magnitude of the electric field at point  $P$  is

- (A) 800 V/m
- (B) 600 V/m
- (C) 400 V/m
- (D) 200 V/m
- (E) 100 V/m

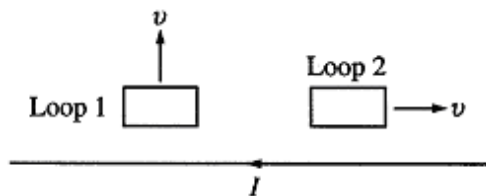

47. Two conducting wire loops move near a very long, straight conducting wire that carries a current  $I$ . When the loops are in the positions shown above, they are moving in the directions shown with the same constant speed  $v$ . Assume that the loops are far enough apart that they do not affect each other. Which of the following is true about the induced electric currents, if any, in the loops?

- | <u>Loop 1</u>                  | <u>Loop 2</u>              |
|--------------------------------|----------------------------|
| (A) No current                 | No current                 |
| (B) No current                 | Counterclockwise direction |
| (C) Clockwise direction        | No current                 |
| (D) Clockwise direction        | Clockwise direction        |
| (E) Counterclockwise direction | Clockwise direction        |

Questions 48-49 relate to the following circuit diagram

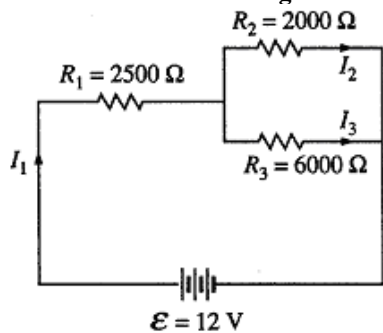

48. What is the current  $I_1$ ?
- (A) 0.8 mA    (B) 1.0 mA  
 (C) 2.0 mA    (D) 3.0 mA  
 (E) 6.0 mA

49. How do the currents  $I_1$ ,  $I_2$ , and  $I_3$  compare?

- (A)  $I_1 > I_2 > I_3$   
 (B)  $I_1 > I_3 > I_2$   
 (C)  $I_2 > I_1 > I_3$   
 (D)  $I_3 > I_1 > I_2$   
 (E)  $I_3 > I_2 > I_1$

Questions 50 -51

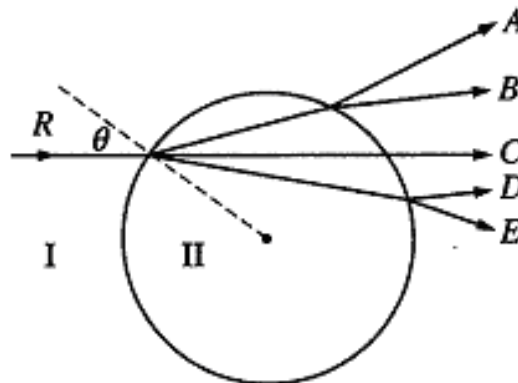

A light ray  $R$  in medium I strikes a sphere of medium II with angle of incidence  $\theta$  as shown above. The figure shows five possible subsequent paths for the light ray.

50. Which path is possible if medium I is air and medium II is glass?

- (A) A  
 (B) B  
 (C) C  
 (D) D  
 (E) E

51. Which path is possible if medium I is glass and medium II is air?

- (A) A  
 (B) B  
 (C) C  
 (D) D  
 (E) E

52. Two fire trucks have sirens that emit waves of the same frequency. As the fire trucks approach a person the person hears a higher frequency from truck X than from truck Y. Which of the following statements about truck X can be correctly inferred from this information?

- I. It is traveling faster than truck Y.  
 II. It is closer to the person than truck Y.  
 III. It is speeding up, and truck Y is slowing down.

- (A) I only  
 (B) III only  
 (C) I and II only  
 (D) II and III only  
 (E) I, II, and III



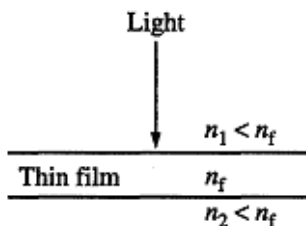

53. A thin film with index of refraction  $n_f$  separates two materials, each of which has an index of refraction less than  $n_f$ . A monochromatic beam of light is incident normally on the film, as shown above. If the light has wavelength  $\lambda$  within the film, maximum constructive interference between the incident beam and the reflected beam occurs for which of the following film thicknesses?

- (A)  $3\lambda$  (B)  $2\lambda$   
 (C)  $\lambda$  (D)  $\lambda/2$   
 (E)  $\lambda/4$

54. An object is placed on the axis of a converging thin lens of focal length 2 cm, at a distance of 8 cm from the lens. The distance between the image and the lens is most nearly

- (A) 0.4 cm  
 (B) 0.8 cm  
 (C) 1.6 cm  
 (D) 2.0 cm  
 (E) 2.7 cm

55. A large lens is used to focus an image of an object onto a screen. If the left half of the lens is covered with a dark card, which of the following occurs?

- (A) The left half of the image disappears.  
 (B) The right half of the image disappears.  
 (C) The image becomes blurred.  
 (D) The image becomes dimmer.  
 (E) No image is formed.

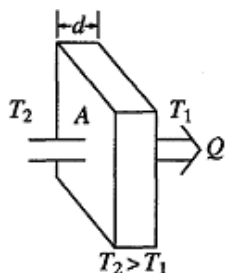

56. In time  $t$ , an amount of heat  $Q$  flows through the solid door of area  $A$  and thickness  $d$  represented above. The temperatures on each side of the door are  $T_2$  and  $T_1$  respectively.

Which of the following changes would be certain to decrease  $Q$ ?

- (A) Increasing  $A$  only  
 (B) Decreasing  $d$  only  
 (C) Increasing  $d$  and  $T_2 - T_1$  only  
 (D) Decreasing  $A$  and  $T_2 - T_1$  only  
 (E) Increasing  $d$ ,  $A$ , and  $T_2 - T_1$

57. A gas with a fixed number of molecules does 32 J of work on its surroundings and 16 J of heat are transferred from the gas to the surroundings. What happens to the internal energy of the gas?

- (A) It decreases by 48 J.  
 (B) It decreases by 16 J.  
 (C) It remains the same.  
 (D) It increases by 16 J.  
 (E) It increases by 48 J.

58. When  $^{10}\text{B}$  is bombarded by neutrons, a neutron can be absorbed and an alpha particle ( $^4\text{He}$ ) emitted. If the  $^{10}\text{B}$  target is stationary, the kinetic energy of the reaction products is equal to the

- (A) kinetic energy of the incident neutron  
 (B) total energy of the incident neutron  
 (C) energy equivalent of the mass decrease in the reaction  
 (D) energy equivalent of the mass decrease in the reaction, minus the kinetic energy of the incident neutron  
 (E) energy equivalent of the mass decrease in the reaction, plus the kinetic energy of the incident neutron

59. The nuclide  $^{214}_{82}\text{Pb}$  emits an electron and becomes nuclide X. Which of the following gives the mass number and atomic number of nuclide X?

	Mass Number	Atomic Number
(A)	210	80
(B)	210	81
(C)	213	83
(D)	214	81
(E)	214	83

60. A 50,000 W radio station transmits waves of wavelength 4 m. Which of the following is the best estimate of the number of photons it emits per second?

- (A)  $10^8$   
 (B)  $10^{22}$   
 (C)  $10^{30}$   
 (D)  $10^{40}$   
 (E)  $10^{56}$

**Questions 61-62**

An object of mass  $m$  is initially at rest and free to move without friction in any direction in the  $xy$ -plane. A constant net force of magnitude  $F$  directed in the  $+x$  direction acts on the object for 1 s. Immediately thereafter a constant net force of the same magnitude  $F$  directed in the  $+y$  direction acts on the object for 1 s. After this, no forces act on the object.

61. Which of the following vectors could represent the velocity of the object at the end of 3 s, assuming the scales on the  $x$  and  $y$  axes are equal?

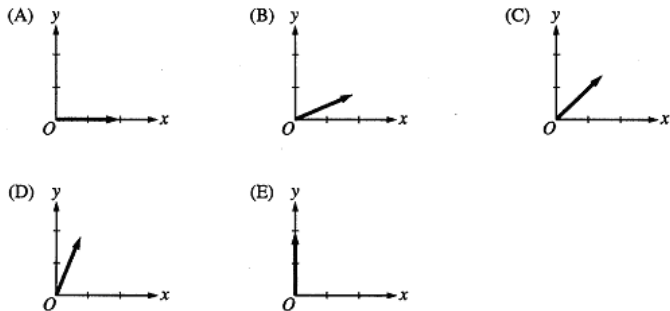

62. Which of the following graphs best represents the kinetic energy  $K$  of the object as a function of time?

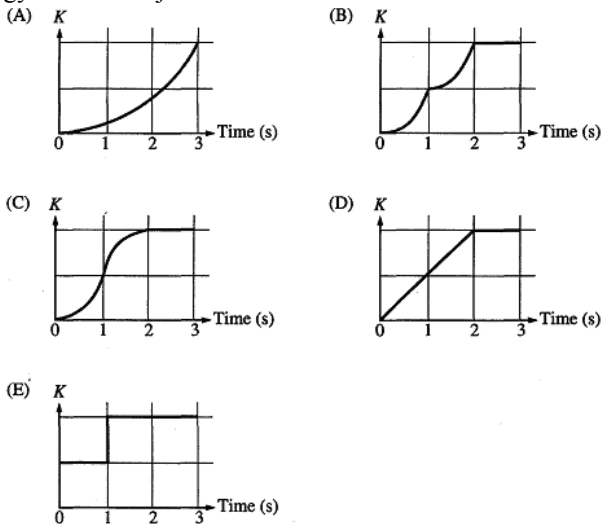

63. The two blocks of masses  $M$  and  $2M$  shown above initially travel at the same speed  $v$  but in opposite directions. They collide and stick together. How much mechanical energy is lost to other forms of energy during the collision?

- (A) Zero
- (B)  $1/2 Mv^2$
- (C)  $3/4 Mv^2$
- (D)  $4/3 Mv^2$
- (E)  $3/2 Mv^2$

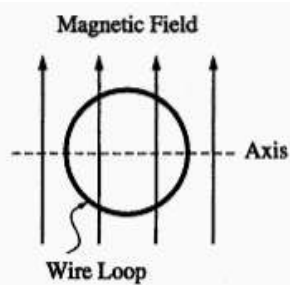

64. A wire loop is rotated in a uniform magnetic field about an axis perpendicular to the field, as shown above. How many times is the induced current in the loop reversed if the loop makes 3 complete revolutions from the position shown?

- (A) One
- (B) Two
- (C) Three
- (D) Six
- (E) Twelve

65. A particle of charge  $Q$  and mass  $m$  is accelerated from rest through a potential difference  $V$ , attaining a kinetic energy  $K$ . What is the kinetic energy of a particle of charge  $2Q$  and mass  $m/2$  that is accelerated from rest through the same potential difference?

- (A)  $K/4$
- (B)  $K/2$
- (C)  $K$
- (D)  $2K$
- (E)  $4K$

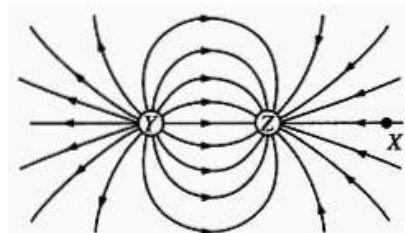

66. The diagram above shows electric field lines in an isolated region of space containing two small charged spheres  $Y$  and  $Z$ . Which of the following statements is true?

- (A) The charge on  $Y$  is negative and the charge on  $Z$  is positive.
- (B) The strength of the electric field is the same everywhere.
- (C) The electric field is strongest midway between  $Y$  and  $Z$ .
- (D) A small negatively charged object placed at point  $X$  would tend to move toward the right.
- (E) Both charged spheres  $Y$  and  $Z$  carry charge of the same sign.

67. A satellite of mass  $m$  and speed  $v$  moves in a stable, circular orbit around a planet of mass  $M$ .

What is the radius of the satellite's orbit?

- (A)  $GM / mv$
- (B)  $Gv / Mm$
- (C)  $GM / v^2$
- (D)  $GmM / v$
- (E)  $GmM / v^2$

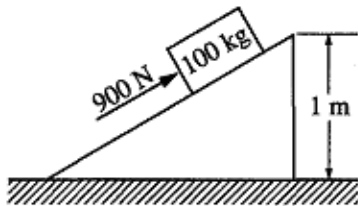

68. A constant force of 900 N pushes a 100 kg mass up the inclined plane shown above at a uniform speed of 4 m/s. The power developed by the 900 N force is most nearly

- (A) 400 W
- (B) 800 W
- (C) 900 W
- (D) 1000 W
- (E) 3600 W

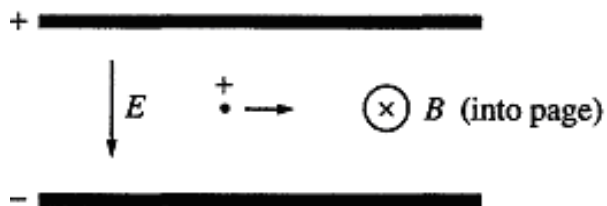

69. As shown above, a positively charged particle moves to the right without deflection through a pair of charged plates.

Between the plates are a uniform electric field  $E$  of magnitude 6.0 N/C and a uniform magnetic field  $B$  of magnitude 2.0 T, directed as shown in the figure. The speed of the particle is most nearly

- (A) 0.33 m/s
- (B) 0.66 m/s
- (C) 3 m/s
- (D) 12 m/s
- (E) 18 m/s

70. A hollow metal sphere 1.0 m in diameter carries a charge of  $4.0 \mu\text{C}$ . The electric field at a distance of 2.0 m from the center of the sphere is most nearly

- (A)  $9.0 \times 10^3 \text{ N/C}$
- (B)  $1.8 \times 10^4 \text{ N/C}$
- (C)  $2.4 \times 10^4 \text{ N/C}$
- (D)  $3.6 \times 10^6 \text{ N/C}$
- (E)  $1.4 \times 10^5 \text{ N/C}$