

Through a point not on a line, there is one and only one line parallel to the given line.

PROOF: SEE EXERCISE 10.

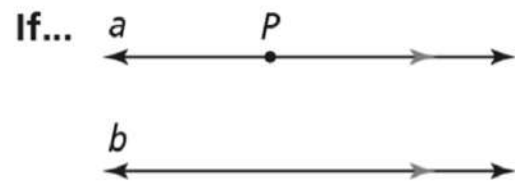
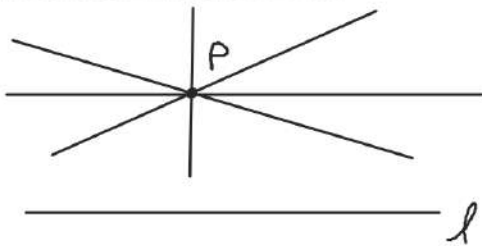

Then... line a is the only line parallel to line b through P .

Triangle Angle-Sum Theorem

The sum of the measures of all the angles of a triangle is 180.

Sum of interior \angle 's of a
triangle is 180°

If...

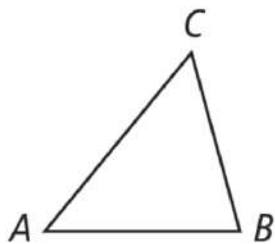

Then... $m\angle A + m\angle B + m\angle C = 180$

What are the values of x and y ?

SOLUTION

$$x + 32 + 78 = 180$$

$$x + 110 = 180$$

$$x = 70$$

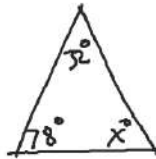

$$y + 78 = 180$$

$$y = 102$$

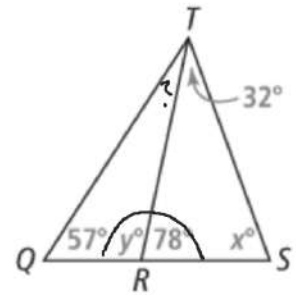

3. a. What are the values of x and y in the figure?

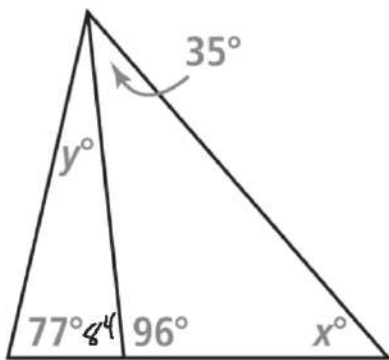

$$35 + x + 96 = 180$$

$$x + 131 = 180$$

$$x = 49$$



$$77 + 84 + y = 180$$

$$161 + y = 180$$

$$y = 19$$

3. b. What are the values of x and y in the figure?

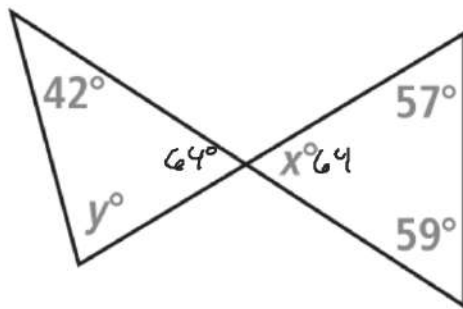

$$59 + 57 + x = 180$$

$$x + 116 = 180$$

$$x = 64^\circ$$

$$64 + 42 + y = 180$$

$$106 + y = 180$$

$$y = 74^\circ$$

Triangle Exterior Angle Theorem

The measure of each exterior angle of a triangle equals the sum of the measures of its two remote interior angles.

↑
Nonadjacent
If...



Then... $m\angle 1 = m\angle 2 + m\angle 3$

A. What is the missing angle measure in the figure?

SOLUTION

$$\begin{aligned} m\angle 1 &= 45 + 75 \\ &= 120 \end{aligned}$$

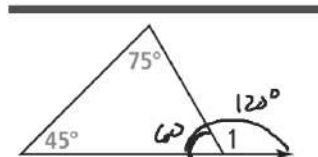

B. What is the missing angle measure in the figure?

SOLUTION

$$\begin{array}{r} 109 = m\angle 2 + 51 \\ - 51 \quad - 51 \\ \hline 58 = m\angle 2 \end{array}$$

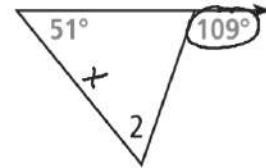

4. a. What is the value of x in the figure?

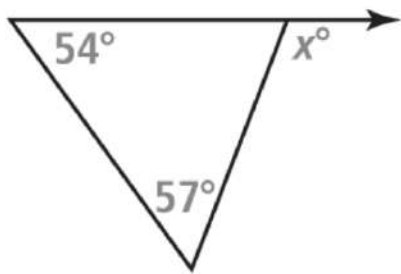

$$x = 54 + 57$$

$$x = 111$$

4. b. What is the value of x in the figure?

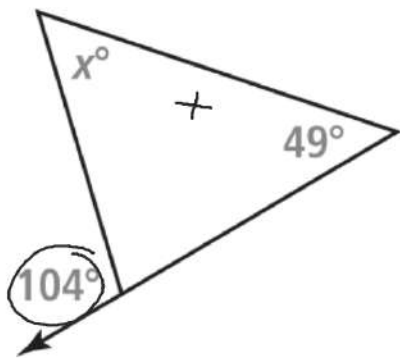

$$\begin{array}{r} 104 = x + 49 \\ -49 \quad -49 \\ \hline x = 55 \end{array}$$

Cheyenne built this display for her ornament collection. Each shelf is parallel to the base. She recalls only the angle measures shown in the diagram. Now she wants to build another just like it. What are the measures of $\angle 1$, $\angle 2$, and $\angle 3$?

$$m\angle 1 = 20^\circ$$

$$m\angle 2 = 55^\circ$$

$$m\angle 3 = 15^\circ$$

$$m\angle 4 = 120^\circ$$

$$m\angle 5 = 80^\circ$$

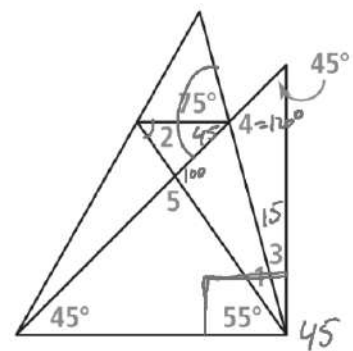
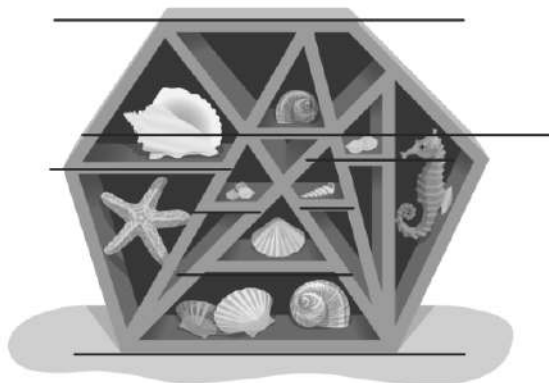

120

3

**5. What are the measures of $\angle 4$ and $\angle 5$?
Explain.**

Mathematical Connections What are the values of x , y , and z ? Use theorems to justify each answer.

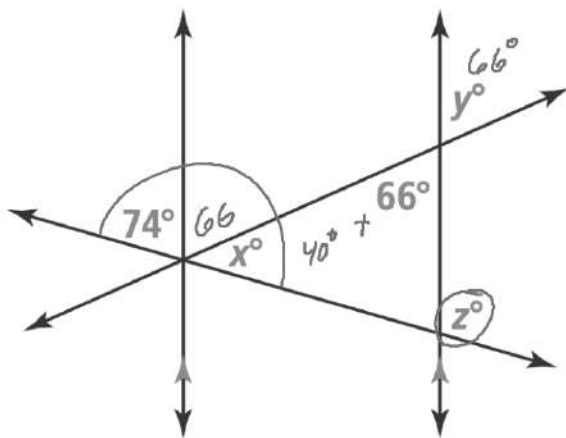

$$x + 74 + 66 = 180$$

$$x = 40$$

$$z = 40 + 66$$

$$z = 106$$

Use Structure Write and solve an equation to find the value of x . What is the measure of each labeled angle?

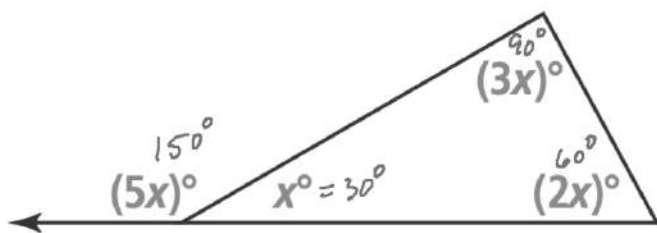

$$5x = 3x + 2x$$

$$5x = 5x$$

$$x = x$$

$$x + 2x + 3x = 180$$

$$6x = 180$$

$$x = 30$$

$$5x + x = 180$$

What are the values of the variables in each figure? SEE EXAMPLES 1-3

16.

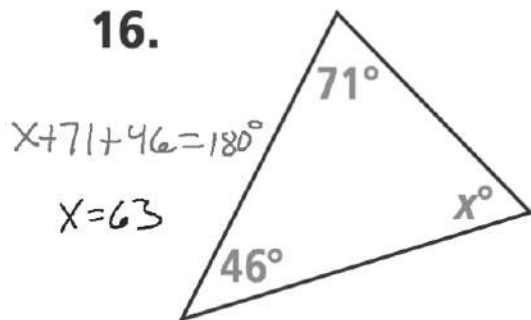

17.

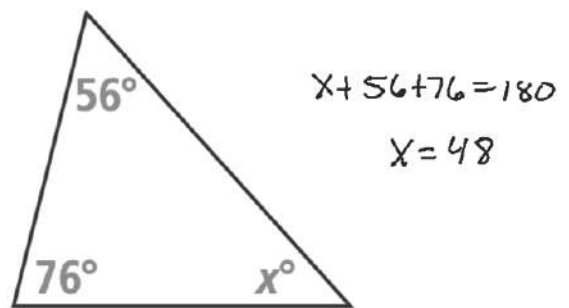

18.

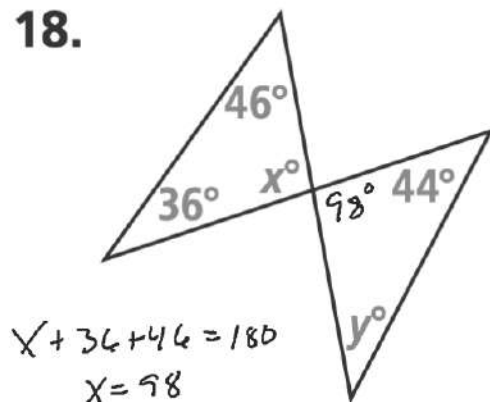

$y + 98 + 44 = 180$
 $y = 38$

19.

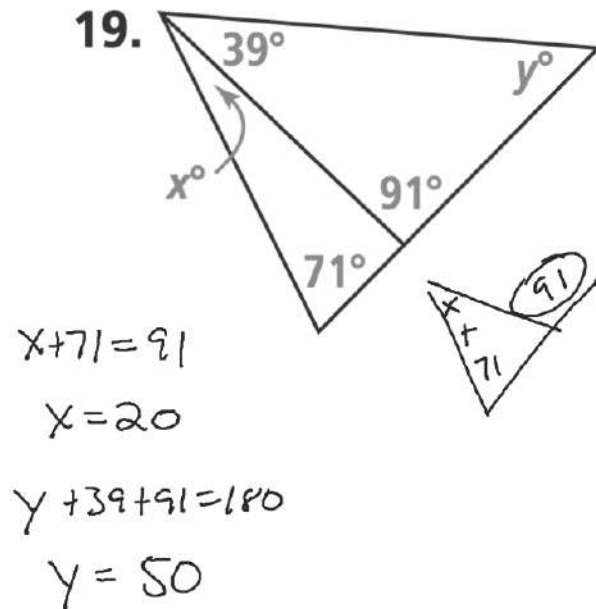

What is the value of x in each figure? SEE EXAMPLE 4

20.

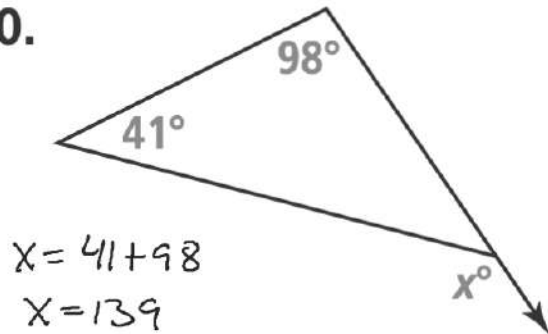

21.

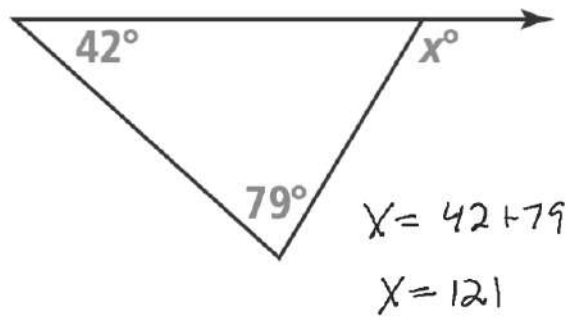

22.

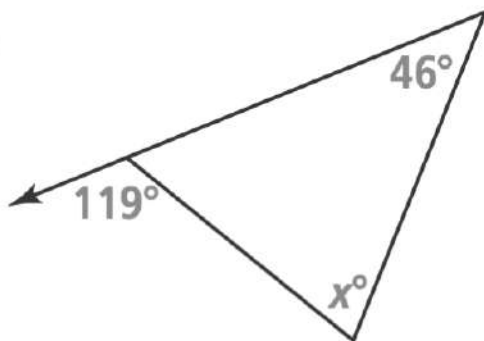

23.

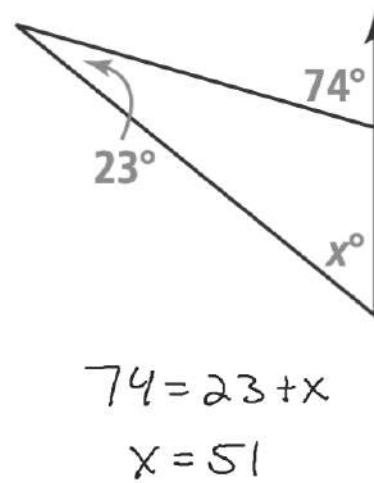

For Exercises 24–27, find the measure of each angle. SEE EXAMPLE 4

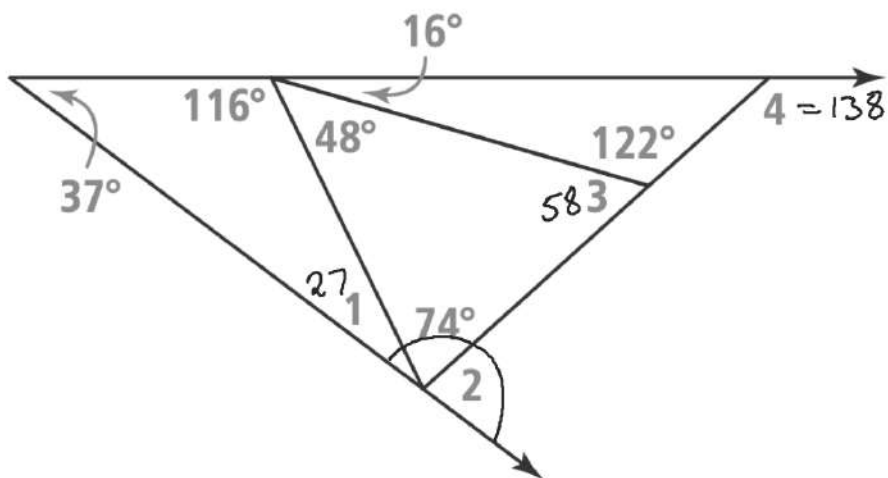

$$m\angle 1 + 37 + 116 = 180$$

$$m\angle 3 + 48 + 74 = 180$$

$$m\angle 4 = 16 + 122$$

$$27 + 74 + m\angle 2 = 180$$

$$m\angle 2 = 79$$

24. $\angle 1$

25. $\angle 2$

26. $\angle 3$

27. $\angle 4$

A pennant is in the shape of an isosceles triangle. One leg of the triangle is fastened to a stick. The stick forms an 84° angle with the other leg. What is the measure of each remote interior angle in the triangle?

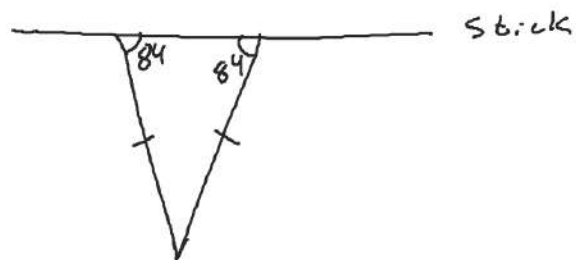

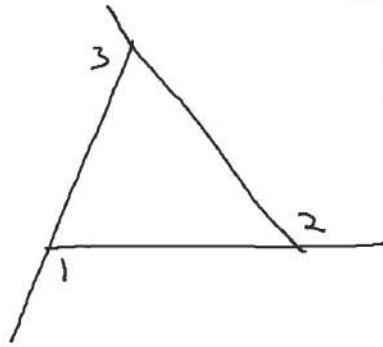

One Exterior angle at
each vertex. Sum of the
3 angles equals 360°

$$m\angle 1 + m\angle 2 + m\angle 3 = 360$$

V.L D.1

