

# Torque and Rotation

Physics

# Torque

- Force is the action that creates changes in linear motion.
- For rotational motion, the same force can cause very different results.
- A torque is an action that causes objects to rotate.
- A torque is required to rotate an object, just as a force is required to move an object in a line.

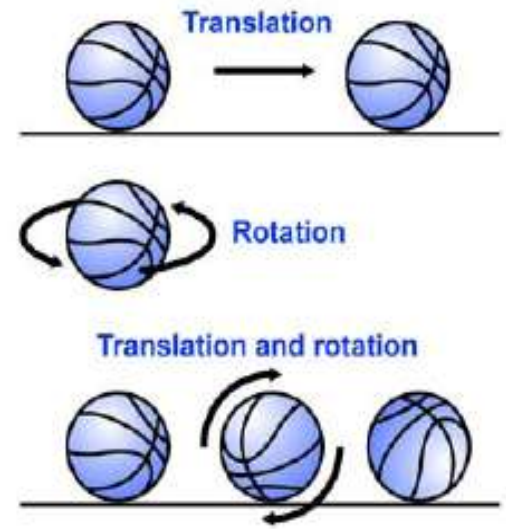

Torque is created by force, but it also depends on where the force is applied and the point about which the object rotates.

---

- For example, a door pushed at its handle will easily turn and open, but a door pushed near its hinges will not move as easily. The force may be the same but the torque is quite different.



# Center of rotation

---

- The point or line about which an object turns is its center of rotation.
- For example, a door's center of rotation is at its hinges.
- A force applied far from the center of rotation produces a greater torque than a force applied close to the center of rotation.

# Line of action

- Torque is created when the line of action of a force does not pass through the center of rotation.

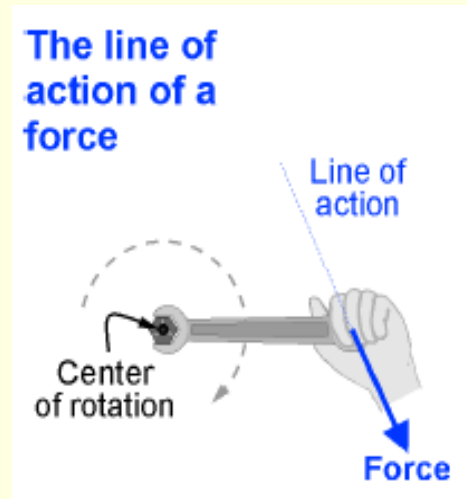

# Force applied must be perpendicular

- The **lever arm** is the perpendicular distance between the line of action of the force and the center of rotation

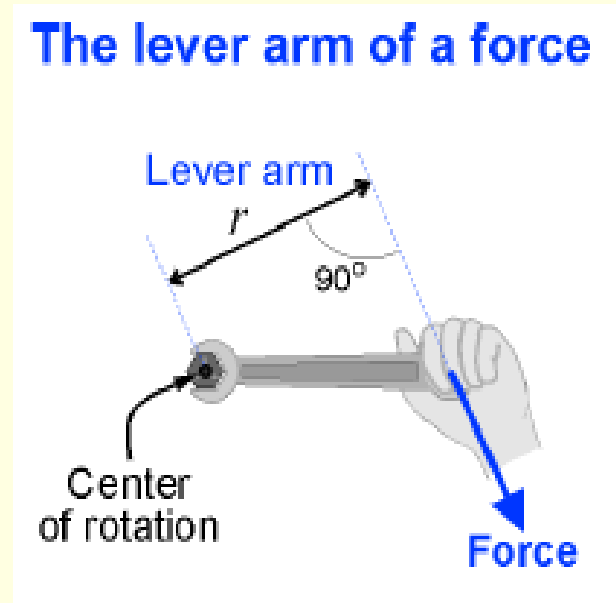

# Calculating torque

- The torque ( $\tau$ ) created by a force is equal to the lever arm ( $r$ ) times the magnitude of the force ( $F$ ).

Torque

$$\begin{array}{c} \text{Torque} \\ (\text{N}\cdot\text{m}) \end{array} \tau = \begin{array}{c} \text{Lever arm} \\ (\text{m}) \end{array} r \times \begin{array}{c} \text{Force} \\ (\text{N}) \end{array} F$$

# Torques can be added and subtracted

---

- If more than one torque acts on an object, the torques are combined to determine the net torque. If the torques tend to make an object spin in the same direction (clockwise or counterclockwise), they are added together.
- If the torques tend to make the object spin in opposite directions, the torques are subtracted.



## Adding torques

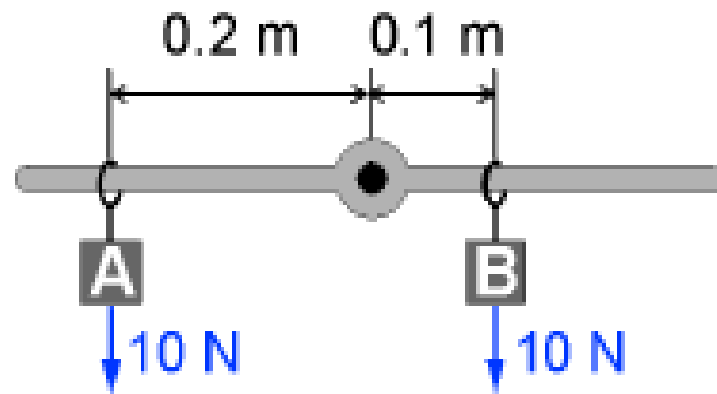

$$\tau_A = +2 \text{ N} \cdot \text{m}$$

$$\tau_B = -1 \text{ N} \cdot \text{m}$$

$$\tau_A + \tau_B = +1 \text{ N} \cdot \text{m}$$

# Units of torque

---

- The units of torque are force times distance, or newton-meters.
- A torque of 1 N-m is created by a force of 1 newton acting with a lever arm of 1 meter.

# You try...

---

- A force of 50 newtons is applied to a wrench that is 30 centimeters long.
- Calculate the torque if the force is applied perpendicular to the wrench so the lever arm is 30 cm.

# You try...

- A force of 50 newtons is applied to a wrench that is 30 centimeters long.
- Calculate the torque if the force is applied perpendicular to the wrench so the lever arm is 30 cm.
  - 1) You are asked to find the torque.
  - 2) You are given the force and lever arm.
  - 3) The formula that applies is  $\tau = rF$ .
  - 4) Solve:
    - $\tau = (-50 \text{ N})(0.3 \text{ m}) = -15 \text{ N.m}$

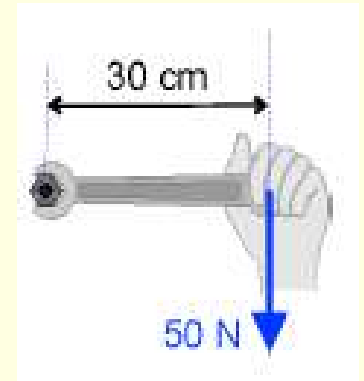

# Net torque is zero

- When an object is in **rotational equilibrium**, the net torque applied to it is zero.
- For example, if an object such as a see-saw is not rotating, you know the torque on each side is balanced

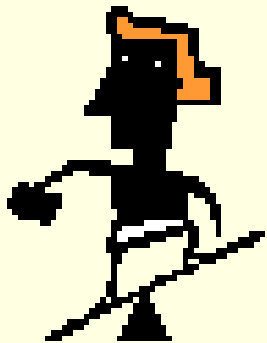

# Unknown forces

---

- Rotational equilibrium is often used to determine unknown forces.
- Any object that is not moving is in rotational equilibrium *and* in translational equilibrium.

# Example

- For example, consider a 10-meter bridge that weighs 500 newtons supported at both ends. A person who weighs 750 newtons is standing 2 meters from one end of the bridge.
- What are the forces ( $F_A$ ,  $F_B$ ) holding the bridge up at either end?

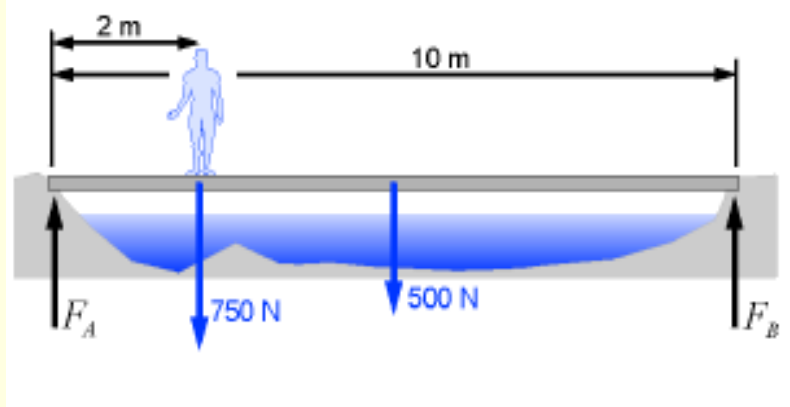

# Example

- For example, consider a 10-meter bridge that weighs 500 newtons supported at both ends. A person who weighs 750 newtons is standing 2 meters from one end of the bridge.
- What are the forces ( $F_A$ ,  $F_B$ ) holding the bridge up at either end?

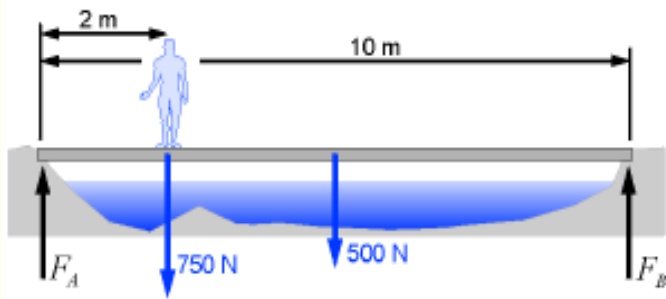

## Vertical equilibrium

$$F_A + F_B = 1,250 \text{ N}$$

$$F_A = 850 \text{ N}$$

## Rotational equilibrium

$$\begin{aligned} & - (750 \text{ N})(2 \text{ m}) \\ & - (500 \text{ N})(5 \text{ m}) \\ & + (F_B)(10 \text{ m}) = 0 \end{aligned}$$

$$- 1,500 - 2,500 + 10 F_B = 0$$

$$F_B = 400 \text{ N}$$



# You Try...

---

- A boy and his cat sit on a seesaw. The cat has a mass of 4 kg and sits 2 m from the center of rotation. If the boy has a mass of 50 kg, where should he sit so that the see-saw will balance?

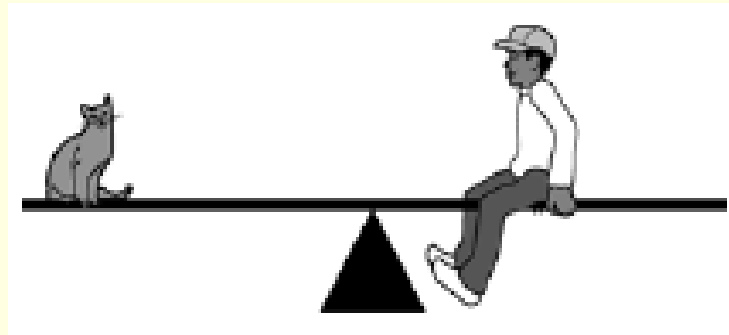

- A boy and his cat sit on a seesaw. The cat has a mass of 4 kg and sits 2 m from the center of rotation. If the boy has a mass of 50 kg, where should he sit so that the see-saw will balance?

- 1) You are asked to find the boy's lever arm.
- 2) You are given the two masses and the cat's lever arm.
- 3) Torque,  $\tau = rF$   
weight:  $F = mg$   
In equilibrium the net torque must be zero.

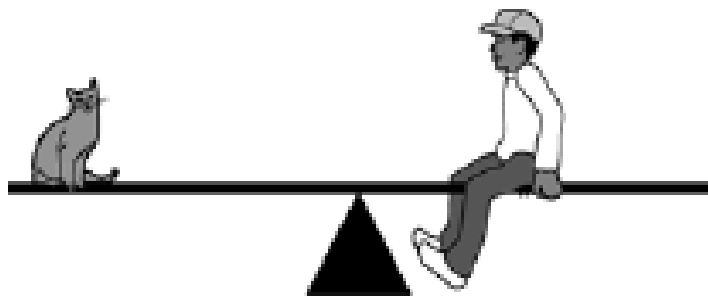

- 4) Solve: For the cat,  
$$\tau = (2 \text{ m})(4 \text{ kg})(9.8 \text{ N/kg})$$
$$= + 78.4 \text{ N}\cdot\text{m}$$

For the boy:

$$\tau = (d)(50 \text{ kg})(9.8 \text{ N/kg})$$
$$= -490 d$$

For rotational equilibrium, the net torque must be zero.

$$78.4 - 490 d = 0$$

$$d = 0.16 \text{ m}$$

The boy must sit quite close (16 cm) to the center.

# Force and lever arm are not always perpendicular

- When the force and lever arm are *not* perpendicular, an extra step is required to calculate the length of the lever arm.

## Torque from angled forces

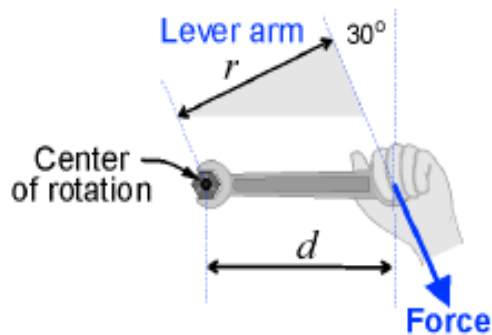

## Triangle relationships

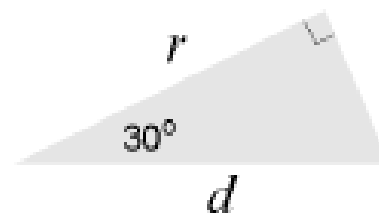

$$\cos 30^\circ = \frac{r}{d}$$

## Finding the torque

$$r = d \cos 30^\circ$$

$$\tau = rF$$

## Solution

$$\tau = Fd \cos 30^\circ$$

# You try...

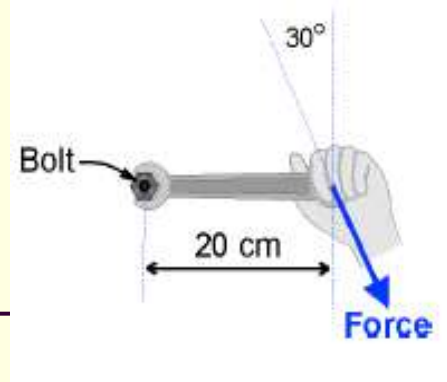

- A 20-centimeter wrench is used to loosen a bolt. The force is applied 0.20 m from the bolt. It takes 50 newtons to loosen the bolt when the force is applied perpendicular to the wrench. How much force would it take if the force was applied at a 30-degree angle from perpendicular?

1) You are asked to find the force.

2) You are given the force and lever arm for one condition.

3) The formula that applies is  $\tau = rF$ .

4) Solve: The torque required to loosen the bolt

$$\tau = (50 \text{ N})(0.2 \text{ m}) = 10 \text{ N}\cdot\text{m}$$

To get the same torque with a force applied at 30 degrees:

$$10 \text{ N}\cdot\text{m} = F \times (0.2 \text{ m})\cos 30^\circ = 0.173 F$$

$$F = 10 \text{ N}\cdot\text{m} \div 0.173 = 58 \text{ N. It takes a larger force.}$$

Three forces labeled A, B, C are applied to a rod which pivots on an axis through its center

$$[\cos(45^\circ) = \sin(45^\circ) = 1/\sqrt{2} = 1/1.4]4$$

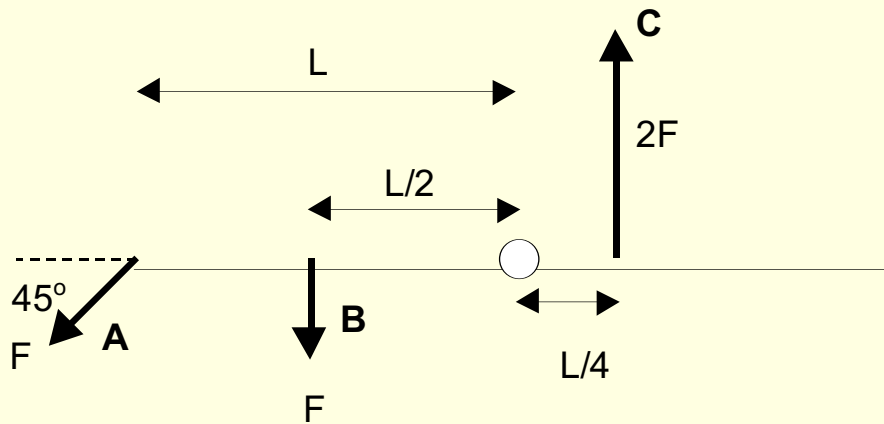

Which force causes the largest magnitude torque?

- A) A
- B) B
- C) C
- D) two or more forces tie for largest size torque.

A door is pushed on by two forces, a smaller force at the door knob and a larger force nearer the hinge as shown. The door does not move.

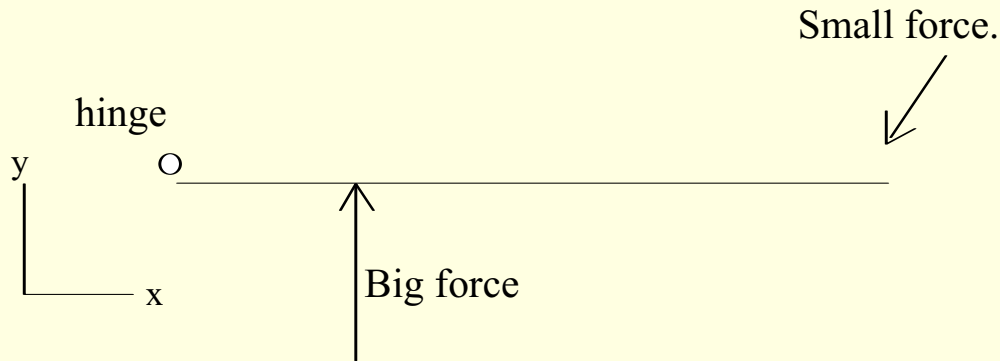

The force exerted on the door by the hinge...

- A) is zero
- B) points  $\uparrow$  (along +y)
- C) points  $\downarrow$  (along -y)
- D) points  $\swarrow$  (lower right, in diagram)
- E) points in some other direction

A mass  $M$  is placed on a very light board supported at the ends, as shown. The free-body diagram shows directions of the forces, but not their correct relative sizes.

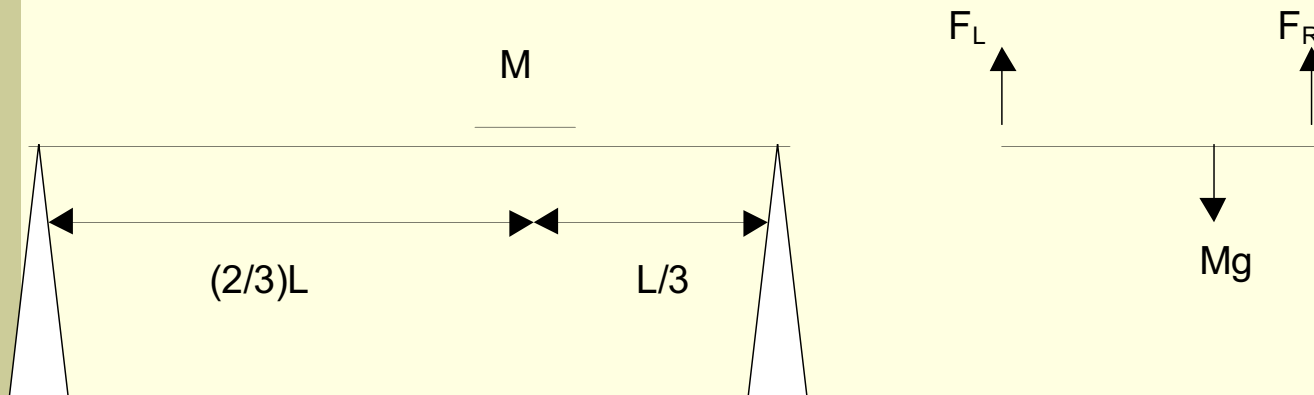

What is the ratio  $\frac{F_R}{F_L}$ ?

(Hint: consider the torque about the mass  $M$ ).

- A)  $2/3$
- B)  $1/3$
- C)  $1/2$
- D)  $2$
- E) some other color.

A planet in elliptical orbit about the Sun is in the position shown.

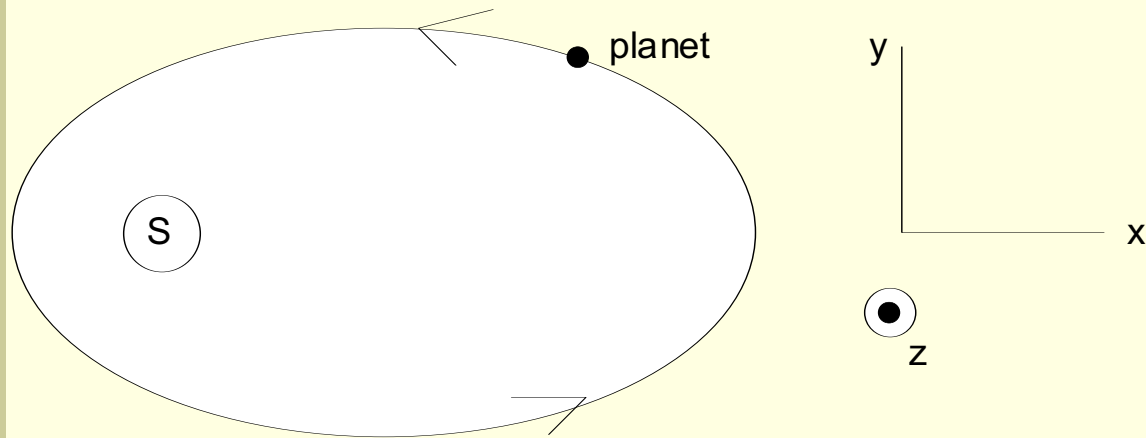

With the origin located at the Sun, the vector torque on the planet..

- A) is zero.
- B) points along +z.
- C) is in the x-y plane.
- D) None of these.



Two light (massless) rods, labeled A and B, each are connected to the ceiling by a frictionless pivot. Rod A has length  $L$  and has a mass  $m$  at the end of the rod. Rod B has length  $L/2$  and has a mass  $2m$  at its end. Both rods are released from rest in a horizontal position.

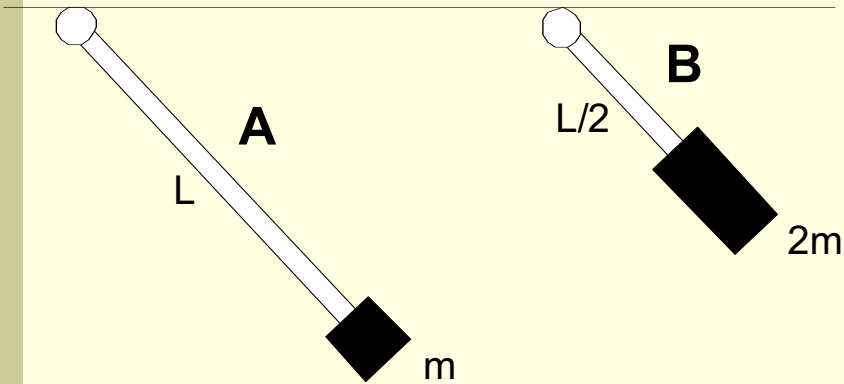

Which one experiences the larger torque?

A) AB) BC) Both have the same size  $\tau$ .

Two light (massless) rods, labeled A and B, each are connected to the ceiling by a frictionless pivot. Rod A has length  $L$  and has a mass  $m$  at the end of the rod. Rod B has length  $L/2$  and has a mass  $2m$  at its end. Both rods are released from rest in a horizontal position.

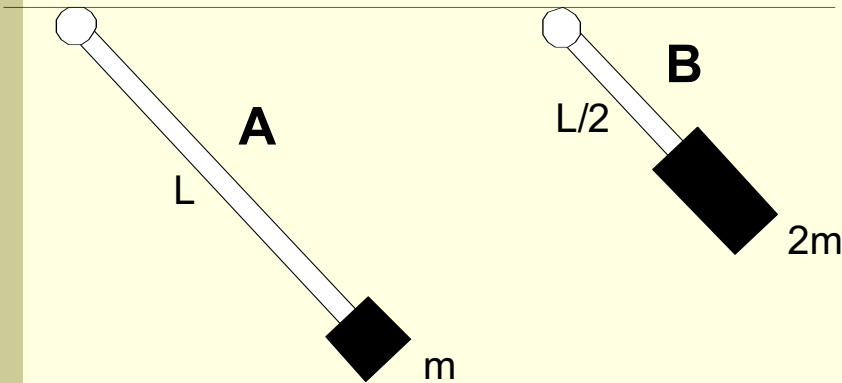

Which one falls to the vertical position fastest?

A) AB) BC) Both fall at the same rate

Hint  $\alpha = \frac{\tau}{I}$