

# MLR: HVAC eBook

---

## Table of Contents

Unit 1: AUTOMOTIVE HEATING, VENTILATION, AND AIR CONDITIONING.....	2
Chapter 1: HVAC Design and Operation - Heating and Engine Cooling .....	2
Chapter 2: HVAC Design and Operation – Refrigeration.....	5
Chapter 3: Principles of Refrigeration .....	10
Chapter 4: Environmental Regulations .....	21
Unit 2: EVALUATING AND DIAGNOSING A/C SYSTEMS .....	26
Chapter 1: Primary Causes – What Can Go Wrong? .....	26
Chapter 2: A Diagnostic Plan .....	32
Unit 3: HVAC SERVICE .....	40
Chapter 1: Refrigerant System Service.....	40
Chapter 2: Testing and Service of Heating and Cooling System Components.....	56
Additional Pages .....	58

## Unit 1: AUTOMOTIVE HEATING, VENTILATION, AND AIR CONDITIONING

### Chapter 1: HVAC Design and Operation - Heating and Engine Cooling

#### *Heating System and Engine Cooling*

The simplest part of an HVAC system is the heater system. Heating the passenger compartment is an easy task, since there is such an abundant supply of waste heat produced in the engine. This waste heat is expelled into the exhaust system and absorbed into the engine parts and oil. The heat that is absorbed by the engine parts must be removed, or the engine would fail in minutes. This is the job of the engine cooling system. We can tap into this heat source to provide heat to the passenger compartment. On vehicles with an automatic transmission, the cooling system is also usually used to cool the transmission fluid. We will not be providing a full discourse on cooling system service here, but since the HVAC system is really all about heat, a brief discussion of the cooling system is a good place to start.

#### The Cooling System

An engine burns cleanest and with the least wear when at its normal operating temperature of around 200 degrees F (93° C). The cooling system is designed to allow fast warm up and then maintain this optimum temperature. This is accomplished with a thermostat that controls coolant circulation in the system.

Coolant is pumped through the engine, where it absorbs the heat of combustion, to the radiator, where this heat is transferred to the atmosphere. The radiator is a heat exchanger. Hot coolant flows through tubes that are folded back and forth many times. The tubes have many fins attached to provide more surface area with which to dissipate heat. Air flowing around the tubes carries away the excess heat, then the coolant returns to the engine to continue the process.

Let's begin at the water pump and follow the coolant flow through a typical system. The pump sends the fluid to the engine block, where it flows through passages around the cylinders. The coolant then flows through the cylinder head and to the thermostat, where it is directed back to the pump (cold/closed) or to the radiator (hot/open).

To heat the passenger compartment, another circuit is added to the cooling system. This circuit pumps hot coolant from the cylinder head through a heater core in the dash, and then back to the pump. In this way, heat can be obtained whether the thermostat is open or closed. The heater core is another heat exchanger, like a small radiator. A blower (fan) blows air through the heater core and into the passenger compartment. A heater control valve controls coolant flow through the heater core, according to the temperature selected by the operator.

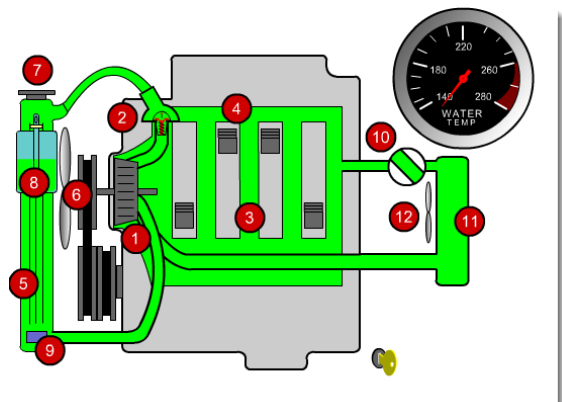

## Coolant

To cover all possible vehicle conditions, the coolant must have a low freezing point, a high boiling point, and the ability to hold a lot of heat. Water is an effective heat carrier, but its freezing and boiling points must be enhanced to make it a suitable coolant. A mixture of water and antifreeze (ethylene glycol) is used for this. Most manufacturers recommend a 50/50 mix, which yields protection against freezing to -35 degrees F (-37° C) and raises the boiling point to 223 degrees F (106° C). Antifreeze also contains an additive package to inhibit corrosion and lubricate the water pump.

The coolant must not boil because when a fluid boils, it cannot absorb any more heat. Its temperature will remain the same, even though the temperature of the surrounding metal may continue to rise. Since coolant temperature can sometimes rise as high as 275 degrees F (135° C), more must be done to raise the coolant's boiling point. The boiling point is further raised by pressurizing the system, typically to about 15 pounds per square inch (psi). This will raise the boiling point another 45 degrees F (25° C). The relationships between heat, pressure, and changes of state (liquid to gas and back) will be examined in detail in the Refrigeration Systems Overview.

As the coolant in the system heats up, pressure is created. The pressure cap on the radiator serves as a pressure relief valve. If the pressure exceeds the cap's rating, it will push the calibrated, spring-loaded valve off its seat, releasing coolant into the overflow reservoir tank. When the radiator cools down, the reduced volume of coolant creates a vacuum in the radiator, pulling open another valve that allows coolant from the reservoir tank to flow back into the radiator.

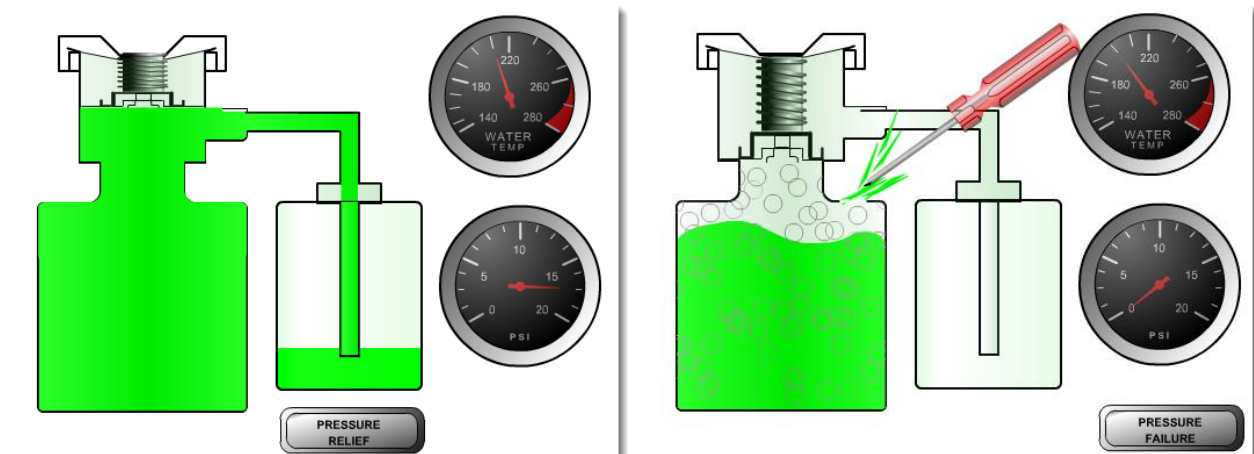

- **CAUTION:** If an engine runs very far outside its optimum temperature range, either too hot or too cold for very long, drivability and emissions problems can occur, in addition to severe engine or other system damage.
- **CAUTION:** If a vehicle's temperature warning light should illuminate, or the gauge rises into the red or "hot" zone, **turn the engine off at once!** Note also that it is possible for an engine to overheat without illuminating the warning light. Excessive engine pinging, very hard or swollen hoses, boiling in the overflow reservoir or escaping coolant, or steaming from the system are indications of overheating.

- **WARNING:** Never attempt to remove the radiator cap with a warm engine, with the engine at operating temperature, or higher! Severe burns can result! Ensure there is no pressure on the system before opening the radiator cap. See your instructor for tips on determining system pressure and temperature.
- **WARNING:** Antifreeze is poisonous and especially toxic to animals.

### Air Delivery Subsystems

The air delivery subsystem of the HVAC system directs “conditioned” (cooled, cleaned and dehumidified) air through the vehicle air outlets. Outside air or re-circulated air is forced through the air-distribution system by the blower motor and fan assembly. From the evaporator, the air flows through a temperature valve where diverter valves direct it through or around the heater core to provide the proper outlet air temperature. The air enters the vehicle passenger compartment through floor outlets, instrument panel outlets, or defroster outlets.

Depending on the vehicle application, the air delivery subsystem may have mechanical, vacuum or electronic controls. A combination of these three control methods may also be used. Note how the components work to delivery air in different operating modes.

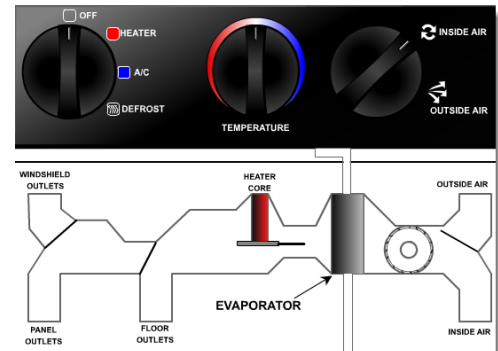

### Basic HVAC Controls

A variety of control strategies and methods are used on different models and makes. For this reason, it is imperative to consult the service manual for the particular vehicle on which you are working. The service manual will not only describe the HVAC controls, but also contains diagnostic flow charts, strategies, and electrical and vacuum schematics for the application.

Control methods will vary most between older and newer vehicles, as heating and AC control have evolved over the years. Early model vehicles used cables to operate different control doors within heating and AC systems, while later model vehicles used vacuums. Modern vehicles are now using electronic motors and actuators.

#### Cable-Operated Heating and AC System

This system is cable-operated. Earlier HVAC systems incorporated an electronic micro switch that would turn the AC compressor off and on depending on the position of the heater control switch.

#### Vacuum-Operated HVAC System

Some later model vehicles used a combination of cables and vacuums to operate the heater and AC system. In a vacuum-operated system a vacuum storage canister is used to create and hold a vacuum. Without a vacuum storage system the blower would change from vent or floor to defrost when the vehicle is accelerated.

### Electronically-Operated HVAC System

Electronically-operated HVAC systems are more complex than previous systems, giving them the advantage of having better system control such as area-specific heating and cooling. Diagnosing an electronic HVAC system will normally require the use of a scan tools with the proper software. Electronic systems require several sensors in order to operate properly. Always use the proper manufacture servicing information when diagnosing and servicing electronic HVAC systems.

### Typical Systems

Systems that you will commonly see in a shop have different names and control strategies, but they can be generally described as being one or a combination of the following:

- Manual Control Systems – may use a control head with cable-operated controls for temperature and vacuum-actuated mode controls. Blower motor/fan speeds are controlled by an electrical switch through resistors and relays.
- Electronic Control Systems – may use a combination of vacuum and electric motors to operate doors/valves for temperature and air delivery. Mode selections are set through an A/C controller. Blower speeds are controlled through resistors and relays.
- Electronic/Automatic Climate Control Systems – may use a microprocessor control head. Numerous sensors provide PCM input for adjustments at the HVAC programmer module. Selected temperatures will be maintained regardless of changes in ambient conditions or air-distribution adjustments. The temperature and air doors are automatically adjusted. Blower speed is determined by a blower control module according to desired interior climate.
- Other controls may include variations on the above strategies, such as controls for dual-zone temperature and air-distribution adjustments by the passengers, controls for rear-compartment A/C systems, and digital/analog steering wheel controls.

#### HVAC Panel Examples

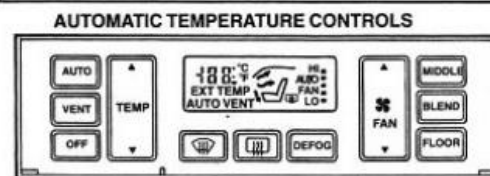
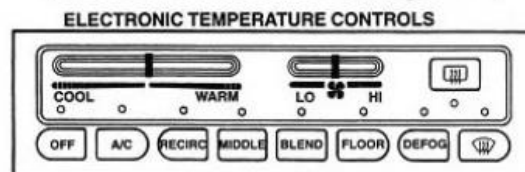
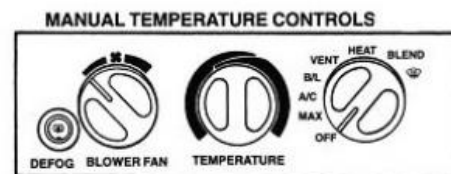

## Chapter 2: HVAC Design and Operation – Refrigeration

### *Refrigeration Systems Overview*

Just as excess heat is removed from the engine and released to the atmosphere, unwanted heat can also be removed from the passenger compartment and likewise disposed of to the atmosphere. This process is a bit more involved than the engine cooling system, and has two phases of operation, one under high pressure / temperature and one under low pressure / temperature. The HVAC system can be thought of as having three subsystems.

## HVAC Subsystems

The heating, ventilation, and air conditioning system can be divided into these three subsystems:

- Refrigeration (low pressure and temperature)
- Cooling (high pressure and temperature)
- Air Delivery

The process of removing heat from air involves evaporation, condensation, and heat transfer. In the **refrigeration subsystem**, refrigerant is circulated to absorb heat from the air entering the passenger compartment. It has refrigerant hoses and lines, pressure control devices and heat transfer components (evaporator). The **cooling subsystem** directs outside air through one of those heat transfer components (condenser) to release the refrigerant's absorbed heat. Its components include an air intake, radiator, and one or more cooling fan(s). A compressor and some type of flow restriction separate these two subsystems. The **air-delivery subsystem** directs the conditioned air back into the passenger compartment, controlling the path, temperature and volume. It has ductwork, air doors/valves, controls, and a blower fan.

For the purpose of this overview, we will look at two commonly used types of automotive refrigeration subsystems. The systems differ in the type of refrigerant control restriction used, and the placement of refrigerant storage/system protection components, but both function in a similar manner. One type uses a Thermostatic Expansion Valve (TXV) to restrict flow into the low-pressure, refrigeration subsystem. These systems have a Receiver/Dryer in the high side, before the TXV. The other type of system uses a calibrated Orifice Tube to restrict the refrigerant flow into the refrigeration subsystem. This type has an Accumulator/Dryer in the low side, before the compressor.

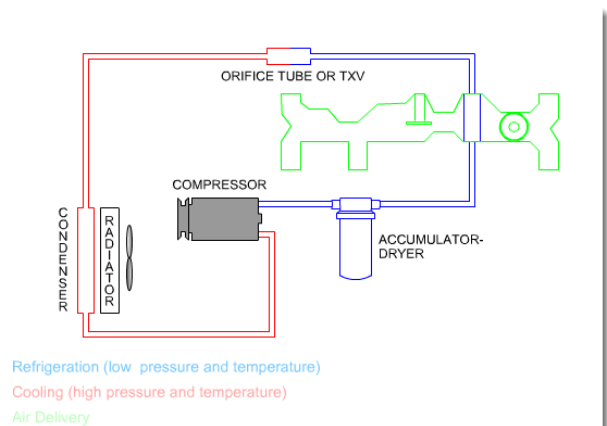

Both of these systems perform the same basic task, and some components are common to all systems. **Refrigerant** is circulated through the system to absorb heat from air entering the vehicle and then release it to the outside air. An **evaporator** transfers heat from passenger compartment air to the liquid refrigerant and causes it to vaporize. A **receiver-dryer** or an **accumulator-dryer** stores refrigerant and removes any moisture. A **compressor** compresses refrigerant vapor into a high pressure, high temperature vapor for more efficient heat removal. A **condenser** transfers heat from this hot refrigerant vapor to the cooler air passing through its fins, changing the vapor into a liquid. An **orifice tube** or a **thermostatic expansion valve** controls the flow of liquid refrigerant and separates the high pressure side of the system from the low pressure side.

### Orifice Tube Systems

An Orifice Tube (OT) subsystem uses an orifice tube to meter and control refrigerant flow and to separate the system high side pressure from the low side pressure. Orifice Tube systems may use a fixed displacement compressor or a variable displacement compressor. On fixed displacement compressor applications, the compressor clutch may be controlled (cycled ON and OFF) by the powertrain control module (PCM) or a pressure switch. The compressor is cycled ON and OFF to maintain the refrigerant pressure within predetermined limits.

Orifice Tube systems that use a variable displacement compressor have pressure controls within the compressor to maintain the low-side refrigerant pressure within predetermined limits, eliminating the need to cycle the compressor on and off.

A typical OT refrigeration system is shown here. Note the components and their locations. The darkened area shows the direction of flow.

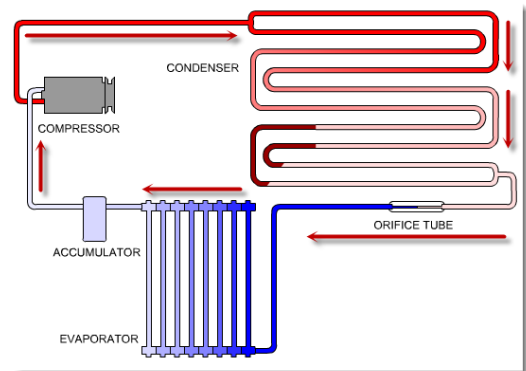

### Thermostatic Expansion Valve (TXV) Systems

Thermostatic Expansion Valve (TXV) systems use a thermostatic expansion valve to control refrigerant flow into the refrigeration subsystem, and to separate the system high side pressure from the low side pressure. The TXV meters the amount of refrigerant entering the evaporator to control heat absorption more accurately. Applications using this system include those with rear refrigeration units. Thermostatic Expansion Valve systems may use a fixed displacement compressor or a variable displacement compressor. Those with a fixed displacement compressor may use a PCM controlled clutch. The PCM or a pressure switch cycles the compressor ON and OFF to maintain the refrigerant pressure within predetermined limits.

TXV systems that use a variable displacement compressor have pressure controls within the compressor to maintain the low-side refrigerant pressure within predetermined limits, eliminating the need to cycle the compressor on and off.

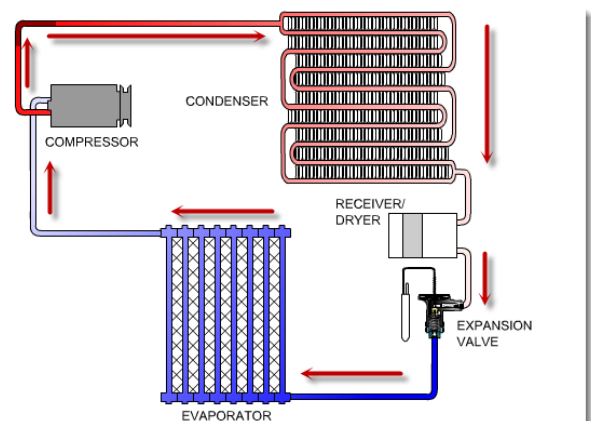

### Orifice Tube and Thermostatic Expansion Valve System Comparisons

Beginning with the compressor, the components of each system are listed in the following chart:

Orifice Tube	Thermostatic Expansion Valve
Compressor	Compressor
Muffler	Muffler
Condenser	Condenser
Orifice Tube	Receiver/Drier
Evaporator	TXV
Accumulator/Drier	Evaporator

Below are visual comparisons of the two systems:

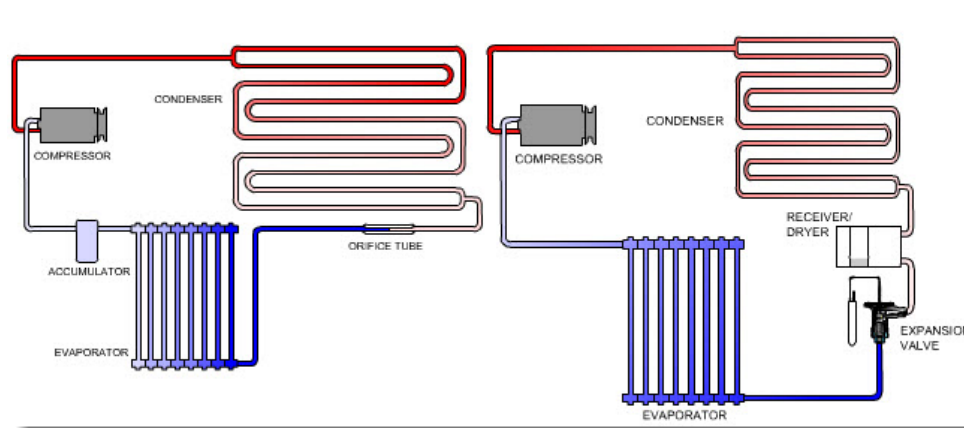

### Cooling Subsystems

The A/C cooling subsystem concerns the cooling of the hot refrigerant. Regardless of the type of refrigeration system used, the heat content in the high pressure, high temperature refrigerant vapor leaving the compressor must be released to the outside air before the air conditioning cycle can repeat itself. This heat transfer takes place at the condenser, which is mounted in front of the radiator so that it receives maximum airflow from vehicle movement and/or coolant fan operation. As hot refrigerant flows through the condenser coils, cooler outside air flows over and around the condenser fins, carrying away heat.

Depending on the vehicle application, the A/C cooling subsystem may have a mechanical coolant fan and/or one or two electric coolant fans.

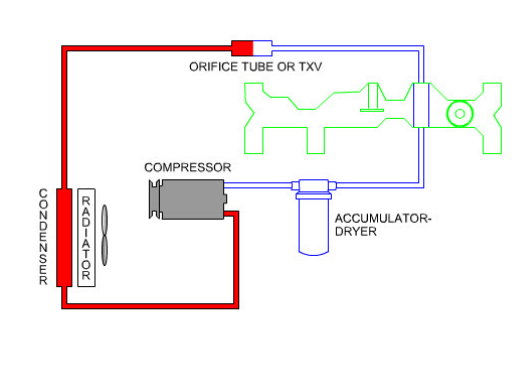



### *Hybrid HVAC Electrical Systems*

The fundamentals of the HVAC system on hybrid are the same as any other automotive HVAC system. In hybrid vehicle the AC compressor is totally electric. In most hybrid vehicles the gasoline engine only runs when the batteries are low. Therefore, hybrid vehicles use an electric compressor so the AC system will still operate even when the gasoline engine is not operating. The operating pressure and operation is the same however, the electrical system on hybrid AC system are very much different.

Hybrid HVAC systems are complex somewhat and controlled by advance electronics. All OEM (original equipment manufacturer) now control AC compressors electronically. In new vehicle, the AC compressor with disengage when a vehicle is accelerated fully throttle based of information received from various engine sensors such as the TPS (throttle position sensor) or APP (accelerator position sensor). Pressure sensors in the steering system will disengage the AC compressor when parking in a tight spot to prevent the engine from stalling.

#### Hybrid AC System Basic Electric Diagnosis

The AC system on late model hybrid vehicle will normally have some built in safety protection that is designed to cut the compressor off when system pressures are too low or too high. Just like non-hybrid systems refrigerant is use to move lubricant throughout the system. If refrigerate become low due to a leak the system will not cool. However, a leak in the AC line will also allow the lubricant to escape the system under pressure. A compressor that is low on refrigerant will not last long. When diagnosing an AC system for electrical problems make sure to follow all manufacture operating procedure. Some AC system will only operate when the controls are set to the correct position. For example, most compressors will not operate unless the blower switch is set to run at some speed.

When the ECM see a low pressure reading the ECM open the AC power circuit, preventing the system from operating with low refrigerant and lubrication.

When the AC system pressures become too high system damage can occur. For this reason some AC systems have a high pressure cutoff switch in the High pressure line. If system pressure exceeds a pre-programmed pressure the AC compressor is disabled. Before attempting to diagnosis an AC system always read pressure gauges first. In most cases, AC problems are traced to low refrigerant or defective AC compressor.

**WARNING:** Never bypass and AC pressure switch unless you have connected the AC gauges to ensure pressures are not extremely too high. Doing so could cause serious personal injury or damage.

**WARNING:** AC compressors in hybrid vehicle operate off very high voltage and should only be serviced by certified hybrid technicians.

## Chapter 3: Principles of Refrigeration

### Overview

In order to diagnose and repair automotive HVAC systems, you must first understand the principles of how air conditioning works, and what provides that delightfully cool air from the car's vents on a hot summer day. These principles are the basis of all air conditioning and refrigeration systems, from home refrigerators and window A/C units to the largest industrial applications.

With the rapidly changing technology of today's automobiles, it's nice to know that these principles do not change, no matter what refrigerant is used or how system controls may change. This is because A/C systems work according to fundamental principles of thermodynamics—laws that never change. Thermodynamics deal with heat and its movement, and that's what air conditioning is all about.

"Now, wait a minute," you may be thinking, "Everybody knows that cold air from the car's vents cools the air in the passenger compartment, so why all this talk of heat?" The answer is that refrigeration systems work using principles of evaporation, condensation, and heat transfer. Let's begin by discussing some properties of heat.

### Heat and Heat Transfer

All matter contains heat, a form of energy. Heat causes the molecules in matter to move—the more heat, the greater the movement of the molecules. The form matter takes (solid, liquid, or vapor) is dependent on the amount of heat it contains. For example, when enough heat is added to water, its state changes to that of vapor, or steam.

Even "cold" matter contains some heat. This is how a home heat pump is able to operate. Though the outside air feels cold to us in winter, a heat pump can remove heat from this air and release the heat into the home. In an automobile air conditioning system, heat is removed from the air entering the passenger compartment and released from the condenser in front of the radiator, into the atmosphere.

Heat always moves from a warmer area to a cooler one. This transfer of heat can happen in three ways: conduction, convection, and radiation. With **conduction**, heat migrates through a solid object. In this manner, an engine block conducts heat from the surface of the combustion chambers to the surface of the cooling jackets. **Convection** occurs when a vapor or liquid flows around a solid of a different temperature, such as when engine coolant flows around the cylinders, carrying away the heat of combustion. **Radiation** carries heat through waves. When the waves strike something of substance, the heat contained in the waves is absorbed. Your hands are warmed by radiation when you hold them in front of a fire. Interestingly, while some heat is radiated away from a car's radiator, much more heat is transferred through convection as air flows through it.

Heat transfer takes place in all three ways in an A/C system, primarily in the condenser and evaporator, which are heat exchangers.

### Heat versus Temperature

It is important to understand that heat and temperature are not the same. Temperature is a measure of heat intensity. Hot objects have a relatively high heat intensity, while cold objects have a relatively low heat intensity.

Heat intensity (temperature) can be measured in degrees Celsius ( $^{\circ}\text{C}$ , sometimes referred to as “centigrade”) or in degrees Fahrenheit ( $^{\circ}\text{F}$ ). Heat quantity can be measured in British Thermal Units (BTUs). One BTU is the amount of heat required to raise the temperature of one pound of water one degree F at sea level.

A cooler object may actually contain more heat energy than a hotter object; volume makes a difference. For example, a cold swimming pool may have a greater total quantity of heat than a hot barbecue grill, though the grill would have a much greater intensity of heat. Consider what would happen if you dumped the hot grill into the pool: it would raise the temperature of the pool very little.



### Factors Affecting Heat Transfer Efficiency

The heat transfer efficiency of automotive A/C systems is greatly affected by the heat load, or the amount of heat that must be absorbed and released by the refrigerant in the system. Note the heat sources and heat transfer components in the illustration. Factors affecting heat load include:

- **High ambient temperatures** - Very high outside temperatures will cause higher inside temperatures. The heat load to be removed from an enclosed space will increase in direct proportion to the heat intensity. As that heat load increases, achieving a temperature that is much lower than the outside temperature will take longer than achieving one that is only slightly lower.
- **High humidity** - Relative humidity is a measure of the moisture content (water vapor) in the air. When this vapor condenses into water on the surface of the evaporator, the heat of vaporization is absorbed by the cooler evaporator surface. This heat is then transferred to the refrigerant in the evaporator, reducing the amount of heat that can be removed from the air. As such, the A/C system cannot cool the vehicle’s interior as efficiently on a very humid day as it can on a dry day.

- Sun load** - The intensity of long wave heat rays from the sun is called sun load. Ambient temperatures, together with the vehicle's type and the color of interior/exterior materials, may increase the effects of sun load and the amount of heat the system must absorb and transfer outside.

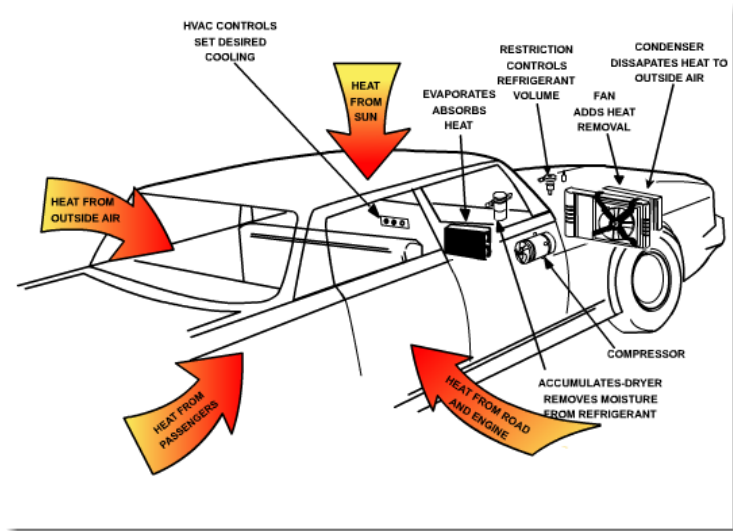

### Evaporation and Condensation

Unlike the coolant in a car's radiator, boiling of the refrigerant in the A/C system is a good thing. In fact, when the system is operating, refrigerant is constantly boiling in the evaporator and condensing back to liquid in the condenser. This is desirable because of an amazing thing that happens when liquid changes to a vapor state—it absorbs a tremendous amount of heat. Conversely, when vapor condenses into liquid, it gives off a great deal of heat.

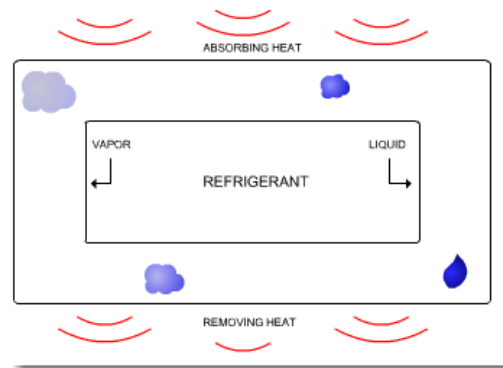

To illustrate this phenomenon, let's take a look at some heat measurements of a familiar substance—water. Suppose we begin with a pound of water in an open pan at a temperature of 70° F. Adding 142 BTUs will raise the temperature of the water to 212° F. That makes sense: one BTU yields a one-degree temperature increase, and this heat is in fact called sensible heat. But, when the water reaches its boiling point of 212° F (at sea level), its temperature can go no higher. Adding more heat will cause it to begin boiling at the same temperature. It requires an additional 970 BTUs to change that pound of water into steam! This is called latent heat, or “hidden heat,” and it's what makes the magic happen in A/C systems.

In summary, it requires the addition of 970 BTUs of heat to change the state of a pound of water at 212° F (100° C) into vapor at 212° F. This heat is absorbed during the change of state.

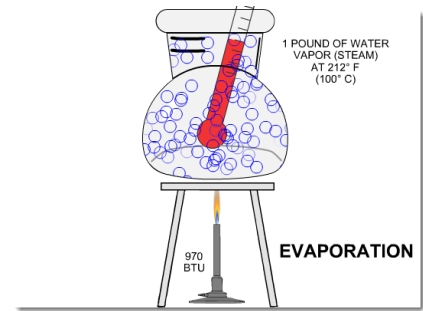
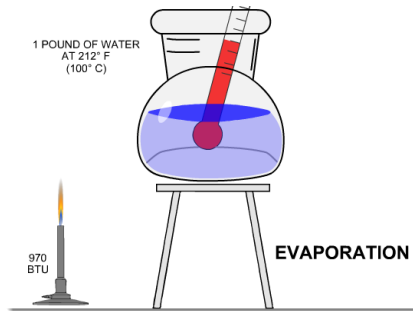

### *Pressure, Temperature, and Changes of State*

Since any given liquid boils and condenses at the same temperature (with the change of state being associated with the latent heat), how can heat be removed from one location and then disposed of in another? The answer is in the relationships between pressure, temperature, and changes of state.

If the pressure acting on a liquid is increased, the boiling point of the liquid is also increased, and if the pressure acting on a liquid is lowered, the boiling point is likewise lowered. Recall that putting an automobile's engine cooling system under pressure increases the coolant's boiling point substantially over its boiling point at atmospheric pressure. Conversely, water boils at a lower temperature on top of a mountain, where air pressure is lower.

Pressurizing a vapor also increases its temperature. When a vapor is pressurized or compressed, its temperature increases because the same amount of heat is concentrated into a smaller area. The temperature of the vapor is increased without adding more heat. This is an important factor in the condensation stage at the condenser. The higher temperature increases the differential between the vapor inside the condenser and the ambient air, aiding condensation and heat transfer to the atmosphere

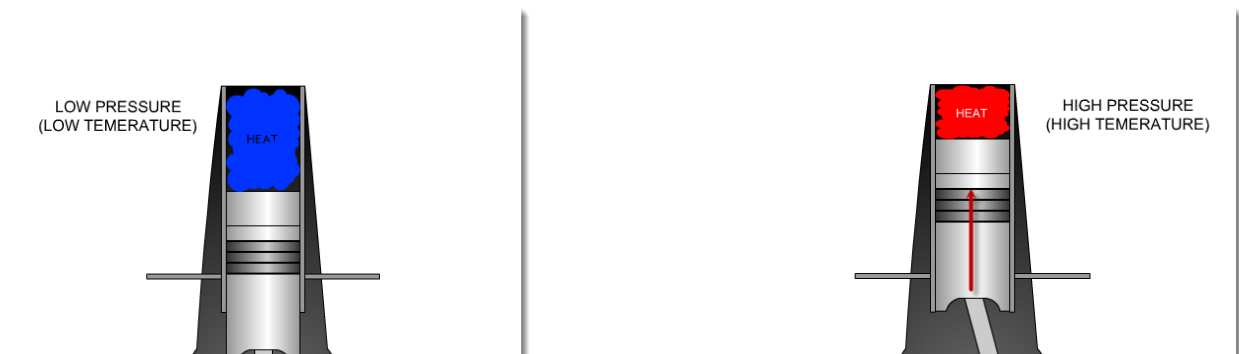

In an engine's cooling system, boiling is undesirable because the coolant must remain in a liquid state in order to circulate through the water jackets and radiator as designed. As you know, once the coolant reaches its boiling point for a given pressure, its temperature can go no higher, and therefore it can absorb no more heat. That's why engine cooling systems are pressurized—the pressure permits the liquid to continue to absorb heat far beyond its boiling point at atmospheric pressure.

An A/C system is divided into two sides: a low-pressure side, and a high-pressure side. The low-pressure, cold side works to remove unwanted heat from the passenger compartment, and the high-pressure, hot side releases this heat to the atmosphere. **It is the difference in pressure between the two sides that permits the changing of states of the refrigerant, and this is what moves the heat from the undesired place (passenger compartment) to the desired place (outside air).**

Here, we should note a very important detail about refrigeration systems. A suitable refrigerant must have a very low boiling point, much lower than that of water. For example, R-134a has a boiling point of  $-15^{\circ}\text{F}$  ( $-26^{\circ}\text{C}$ ) at atmospheric pressure.

### *The Basic Refrigeration Cycle*

Now that we have established some heat and refrigeration principles, let's take a more detailed look at the refrigeration cycle. Automotive A/C systems remove heat and humidity from air entering the vehicle and release it to the outside by evaporating, compressing and condensing a refrigerant. The A/C system uses pressure and heat transfer to change the state of refrigerant from a cool, low pressure liquid to a hot, high pressure vapor and back to liquid as the process continuously repeats itself.

The refrigeration cycle depends on refrigerant flowing and changing states in a closed loop that has several components connected with hoses and tubing. **The A/C system must have:**

#### **Evaporator:**

An evaporator that has cool, low pressure liquid refrigerant flowing through it to absorb heat (and condense moisture) from the passenger compartment air. As this heat is absorbed, the liquid refrigerant changes state into warmer, low pressure vapor.

Evaporator

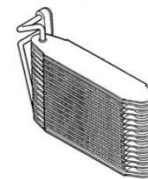

#### **Compressor:**

A compressor that uses pressure to concentrate the refrigerant's heat. It compresses the warm, low pressure vapor into hot, high pressure vapor to ensure efficient heat removal at the condenser.

Compressor

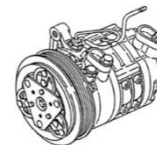

Condenser

#### **Condenser:**

A condenser that transfers heat from the hot, high pressure refrigerant vapor coming from the compressor to the outside air. As the absorbed heat is removed, the refrigerant vapor is condensed back into a cooler, high pressure liquid.



**Refrigerant:**

A refrigerant that absorbs and releases heat as it changes states between liquid and vapor and back to liquid.

**Lubricant:**

A lubricant (refrigerant oil) that is added to the refrigerant during system charging to provide compressor lubrication.

Controlling Refrigerant in A/C Systems*Pressure and Flow*

A/C systems require some method of controlling refrigerant pressure and flow. Unless the compressor has something to push against, it cannot build up system pressure and maintain the conditions needed for refrigeration.

System pressures are critical. Low side pressures keep the refrigerant boiling point at the correct level for absorbing heat through vaporization. Higher pressures would slow vaporization and heat absorption. Likewise, high side pressures allow the refrigerant to condense at normal ambient temperatures. Lower pressures would slow condensation and heat release.

A metering device helps the compressor build pressure and maintain the refrigeration cycle. Depending on the system, an orifice tube with a fixed diameter opening for metering refrigerant flow, or a thermal expansion valve that varies flow based on evaporator outlet temperatures is used.

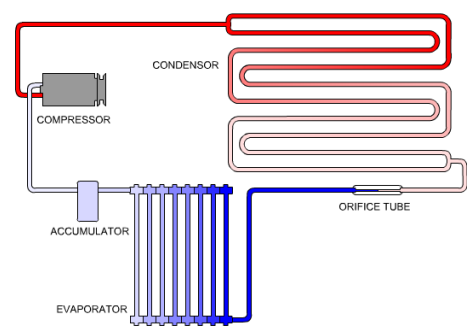
High and Low Pressure Areas

We have said that the refrigeration system is divided into a high pressure area (high side) and a low pressure area (low side). The high side extends from the compressor outlet, through the condenser, to the metering device inlet. In operation, it is also the high temperature side. The low side starts at the metering device outlet, includes the evaporator and accumulator, and continues to the compressor inlet. During operation, the low pressure side is also the low temperature side.

The high pressure and low pressure sides of an operating A/C refrigeration subsystem can be identified in several ways:

- Tube diameter - High side tubing is often smaller than low side tubing.
- Feel - High side tubing is always hotter than low side tubing.
- Sight - Low side tubing is often cool enough to collect frost or water droplets on high humidity days.
- Pressure - A/C system pressures can be measured with a gauge set.
- Refrigerant temperature - Refrigerant temperatures can be measured with various methods on either the low or the high pressure sides.

### Systems Operation Overview

Regardless of system design, all automotive A/C systems depend on the continuous interaction of the compressor with a flow control device, such as an orifice tube or thermal expansion valve (TXV). Flow volume may be adjusted based on pressure temperature load, monitored at a key location. Locate the high- and low-pressure sides and note the state of the refrigerant as we follow the flow in the animation. In an operating A/C system, this process continuously repeats.

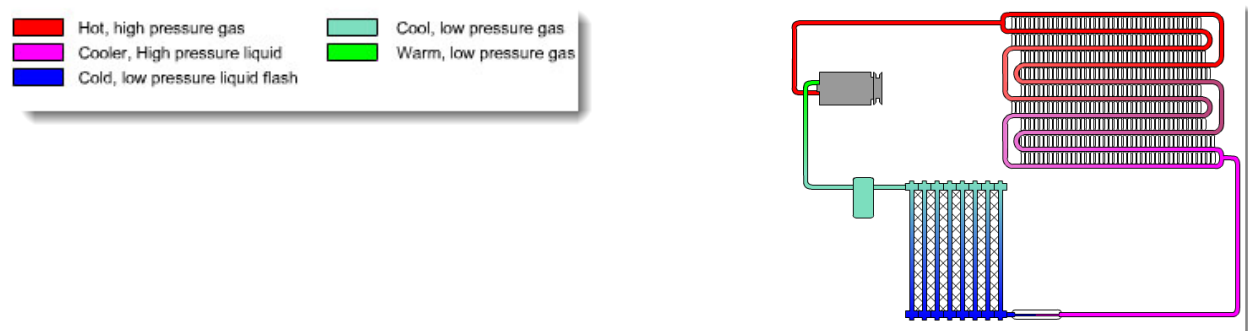

### Refrigerant

We have seen how the state of refrigerant changes from liquid to vapor, and back to liquid during the course of the refrigeration cycle. The refrigerant is a chemical that must have certain properties, including a very low boiling point, in order to be efficient and safe.

There are currently two refrigerants used in different A/C systems: R-12 and R-134a. R-12, or "Freon," was used for many years, and was efficient and inexpensive, but due to environmental concerns, it is being phased out. Vehicles manufactured before 1992 use R-12. Vehicles made in 1995 and later use R-134a. During the transition years, both of the systems were used.

The two refrigerants **are not interchangeable**. An identification label can be found on the compressor or elsewhere under the hood. To prevent contamination of systems and service equipment, the service valve design was changed for the R-134a systems. R-134a system service valves are either quick-connect fittings or metric-threaded. Most R-12 systems can be retrofitted for R-134a, so be on the lookout for converted systems. If an R-12 system has suffered significant component failure, it may be a good candidate for retrofitting. R-12 is becoming prohibitively expensive as available quantities dwindle.



**R-12 [white]****R-134a [light blue]**

Since the two types of refrigerant do not mix and are not interchangeable, each type requires dedicated equipment. We will provide some information for identification and comparison purposes here; however, we will primarily be discussing the service of R-134a systems in this course. If you will be servicing R-12 systems, be sure to refer to the R-12 service equipment manual and vehicle manufacturer service materials.

### Refrigerant-12

R 12 is a CFC type refrigerant (dichlorodifluoromethane) with all the qualities necessary to be a good heat transfer medium. It has a boiling point of  $-22^{\circ}\text{F}$  ( $-30^{\circ}\text{C}$ ) at sea level, and is harmless to refrigeration system materials, such as steel, copper, iron, aluminum and neoprene rubber. It readily mixes with 525 viscosity mineral oil for system lubrication. It is neither explosive nor flammable, and is not corrosive except when in contact with water.

### Refrigerant-134a

R 134a, the only OEM approved replacement for R 12, is an HFC type refrigerant (tetrafluoroethane) that does not deplete the ozone layer of the atmosphere. It has a boiling point of  $-15^{\circ}\text{F}$  ( $-26^{\circ}\text{C}$ ). In many ways, it works and acts the same as R 12. Harmless to refrigeration system materials, it is nonflammable and it absorbs, transfers and releases heat efficiently. However, it does not mix well with mineral oil for system lubrication; synthetic oils must be used with R 134a refrigerant. Check the manufacturer's specs, under-hood labels, or compressor tags for the correct oil.

R-134a has a smaller-sized molecule than R-12, and so it has a higher potential for leakage than R-12; however, improvements in the design of fittings, and the use of barrier-type hoses offset this difference. There are numerous other differences between R 12 and R 134a refrigeration systems, as shown in the chart.

**CAUTION:** Beware of refrigerant blends and hydrocarbon-based refrigerants! These blends, besides causing possible damage to system components and service equipment, can be highly flammable! Only R-12 and R-134a are approved by automakers for use in their respective systems.

Differences between R-12 and R-134a Systems		
Subject	R-12 Systems	R-134a Systems
Container Color	White	Light Blue
Container Identification	R-12	R-134a
Container Fitting	7/16" x 20, 1/4" Flare	1/2" x 16 ACME
Chemical Name	Dichlorodifluoromethane	Tetrafluoroethane
Ozone Depletion Potential	1	0
Halocarbon Global Warming Potential	3.0	Less than 0.3
Boiling Point at Sea Level	$-21.62^{\circ}\text{F}$ , $-29.79^{\circ}\text{C}$	$-15.07^{\circ}\text{F}$ , $-26.15^{\circ}\text{C}$
Refrigerant Oil	Mineral Based	Polyalkaline Glycol (PAG) or Ester
Refrigerant Oil Hygroscopicity	0.005% by weight	2.3%-5.6% by weight
Compressor Identification	Refrigerant type identified on the label	
Condenser	Standard	Increased heat transfer
Desiccant Type	XH5, XH7 or XH9	XH5, XH7 or XH9
Hose Construction	Nylon liner optional	Nylon liner required
High Side Service Port	3/8" x 24 external threads	Accepts the larger, high-side coupler
Low Side Service Port	1/4" Flare external threads	Accepts the smaller, low-side quick coupler.
Valve Core	TV5 thread, Teflon seal, internal spring, different pin height	M-6 thread, O-ring seal, external spring, standard pin height

### Refrigerant Pressure-Temperature Relationships

As in the previous discussion of the effects of pressure and temperature on the boiling points of liquids and the heat content of gases, a precise pressure-temperature relationship exists between both liquid and vaporized refrigerants. Heating a refrigerant causes it to expand as its temperature increases. When confined in a sealed container, warmer refrigerant will have a higher pressure than cooler refrigerant—even without a compressor.

For every temperature increase, a corresponding increase in pressure will be seen in a container of R 12 or R 134a refrigerant. As shown in the charts, there is a distinct pressure temperature relationship for each refrigerant. Note that R 134a systems operate with slightly lower evaporator pressures and slightly higher condenser pressures, as compared to R 12 systems. This is because R 134a tends to vaporize faster but condenses slower.

In an A/C system, pressure readings are expressed either as positive gauge pressure (above atmospheric, in psi or kPa) or as negative gauge pressure (below atmospheric, as vacuum, in inches of mercury, or inHg). The pressure characteristics of R 134a differ from those of R 12. Note that the boiling point of R 134a is 6° F (3° C) higher than R 12. This changes the pressure temperature relationship, so R 134a system gauge readings will differ slightly from those on R 12 systems.

The pressure temperature relationship can be easily demonstrated. A pressure gauge attached to a container of R 12 at 70° F (21 °C) will show a pressure of about 70 psi (484 kPa). A container of R 134a at the same temperature will show a pressure of about 71 psi (487 kPa) – only slightly higher than that measured for R 12. But, as the temperature increases, so does the pressure differential between the two refrigerants. Measuring the pressure at 100° F (38° C), the gauge will read about 117 psi (808 kPa) on an R 12 container and about 124 psi (857 kPa) on an R 134a container.

These pressure temperature relationships are important in your diagnosis and service work. If the refrigerant in an A/C system is not pure (contaminated or a non approved blend) or if the refrigerant in a container is contaminated with air or water, the pressure temperature relationship will not match that shown in the charts.

**CAUTION:** R 12 and R 134a refrigerants should never be mixed, and they should always be used with the correct lubricating oil!

R-12 Temperature/Pressure Relationship			
Temperature	Pressure		Temperature
16° F (-9° C)	18 PSI (127 kPa)		102° F (39° C)
18° F (-8° C)	20 PSI (136 kPa)		104° F (40° C)
20° F (-7° C)	21 PSI (145 kPa)		106° F (41° C)
22° F (-6° C)	22 PSI (155 kPa)		108° F (42° C)
24° F (-4° C)	24 PSI (165 kPa)		110° F (43° C)
26° F (-3° C)	25 PSI (175 kPa)		112° F (44° C)
28° F (-2° C)	27 PSI (185 kPa)		114° F (46° C)
30° F (-1° C)	28 PSI (196 kPa)		116° F (47° C)
32° F (0° C)	30 PSI (207 kPa)		118° F (48° C)
34° F (1° C)	32 PSI (219 kPa)		120° F (49° C)
36° F (2° C)	33 PSI (230 kPa)		122° F (50° C)
38° F (3° C)	36 PSI (249 kPa)		124° F (51° C)
40° F (4° C)	37 PSI (255 kPa)		126° F (52° C)
45° F (7° C)	42 PSI (287 kPa)		128° F (53° C)
50° F (10° C)	47 PSI (322 kPa)		130° F (54° C)
55° F (13° C)	52 PSI (359 kPa)		135° F (57° C)
60° F (16° C)	58 PSI (398 kPa)		140° F (60° C)
65° F (18° C)	64 PSI (440 kPa)		145° F (63° C)
70° F (21° C)	70 PSI (484 kPa)		150° F (66° C)
75° F (24° C)	77 PSI (531 kPa)		155° F (68° C)
80° F (27° C)	84 PSI (580 kPa)		160° F (71° C)
85° F (30° C)	92 PSI (633 kPa)		165° F (74° C)
90° F (32° C)	100 PSI (688 kPa)		170° F (77° C)
95° F (35° C)	108 PSI (746 kPa)		
100° F (38° C)	117 PSI (808 kPa)		
Evaporator range		Condenser range	
R-134a Temperature/Pressure Relationship			
Temperature	Pressure		Temperature
16° F (-9° C)	15 PSI (106 kPa)		102° F (39° C)
18° F (-8° C)	17 PSI (115 kPa)		104° F (40° C)
20° F (-7° C)	18 PSI (124 kPa)		106° F (41° C)
22° F (-6° C)	19 PSI (134 kPa)		108° F (42° C)

24° F (-4° C)	21 PSI (144 kPa)		110° F (43° C)	147 PSI (1012 kPa)
26° F (-3° C)	22 PSI (155 kPa)		112° F (44° C)	152 PSI (1045 kPa)
28° F (-2° C)	24 PSI (166 kPa)		114° F (46° C)	157 PSI (1079 kPa)
30° F (-1° C)	26 PSI (177 kPa)		116° F (47° C)	162 PSI (1114 kPa)
32° F (0° C)	27 PSI (188 kPa)		118° F (48° C)	167 PSI (1149 kPa)
34° F (1° C)	29 PSI (200 kPa)		120° F (49° C)	172 PSI (1185 kPa)
36° F (2° C)	31 PSI (212 kPa)		122° F (50° C)	177 PSI (1222 kPa)
38° F (3° C)	33 PSI (225 kPa)		124° F (51° C)	183 PSI (1260 kPa)
40° F (4° C)	35 PSI (238 kPa)		126° F (52° C)	188 PSI (1298 kPa)
45° F (7° C)	40 PSI (272 kPa)		128° F (53° C)	194 PSI (1337 kPa)
50° F (10° C)	45 PSI (310 kPa)		130° F (54° C)	200 PSI (1377 kPa)
55° F (13° C)	51 PSI (350 kPa)		135° F (57° C)	215 PSI (1481 kPa)
60° F (16° C)	57 PSI (392 kPa)		140° F (60° C)	231 PSI (1590 kPa)
65° F (18° C)	64 PSI (438 kPa)		145° F (63° C)	247 PSI (1704 kPa)
70° F (21° C)	71 PSI (487 kPa)		150° F (66° C)	264 PSI (1823 kPa)
75° F (24° C)	78 PSI (540 kPa)		155° F (68° C)	283 PSI (1948 kPa)
80° F (27° C)	88 PSI (609 kPa)		160° F (71° C)	301 PSI (2079 kPa)
85° F (30° C)	95 PSI (655 kPa)		165° F (74° C)	321 PSI (2215 kPa)
90° F (32° C)	104 PSI (718 kPa)		170° F (77° C)	342 PSI (2358 kPa)
95° F (35° C)	114 PSI (786 kPa)			
100° F (38° C)	124 PSI (857 kPa)			
Evaporator range				
Evaporator range		Condenser range		

## Chapter 4: Environmental Regulations

### *Environmental Regulations Overview*

R-12 has been used in refrigeration systems since its introduction in 1930. However, R-12 is a chlorofluorocarbon (CFC), and due to environmental concerns, countries around the world have agreed to end its production. The US Environmental Protection Agency (EPA) has issued regulations regarding the sale and service of refrigerants used in A/C systems, including R-12 and R-134a, as well as recovery and recycling equipment.

Under Section 609 of the 1990 Clean Air Act, it is illegal to vent any refrigerant (either R-12 or R-134a) to the atmosphere during A/C system service. Furthermore, technicians who repair or service A/C systems must be trained and certified on the regulations, refrigerant handling, and environmental issues by an EPA approved organization. Many such organizations are listed at the EPA website, and some of them offer refrigerant recovery and recycling information and an open-book certification test online. ASE and MACS are two popular sites that offer this service.

The EPA website offers many free fact sheets about refrigerants and the regulations that govern motor vehicle air conditioning in the US. We have reproduced one for you here, and the others are available at the .

Just the Facts for MVACs: EPA Regulatory Requirements for Servicing of Motor Vehicle Air Conditioners

### *Our Threatened Ozone Layer*

The [ozone layer](#) acts as a blanket in the stratosphere that protects us from harmful ultraviolet ([UV](#)) radiation. Scientists worldwide believe that man-made chemicals such as [CFC-12](#) (also known by the trade name Freon) are rapidly destroying this layer of gas 10 to 30 miles above the earth's surface. Strong UV radiation breaks the CFC-12 molecules apart, releasing chlorine. A single chlorine atom can destroy over one hundred thousand ozone molecules. Ozone loss in the atmosphere is likely to lead to an increase in cataracts and skin cancer, which is now one of the fastest growing forms of cancer, and could weaken the human immune system. In the U.S., one person dies of skin cancer every hour. Agriculture, as well as plant and animal life, may also be dramatically affected.

**Earth as Seen from Space**



**The Ozone Layer**

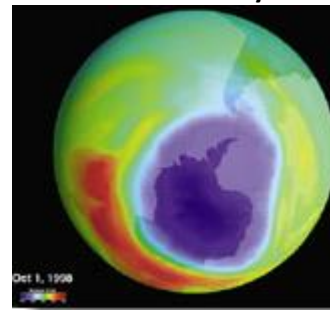

Remember that ozone is "[good up high, bad nearby](#)": even though it protects us when it is in the stratosphere, ozone at ground level can be harmful to breathe and is a prime ingredient in smog. Many man-made sources such as tailpipe emissions from cars contribute to ground-level ozone.

#### Global Action to Protect the Ozone Layer

The United States has joined over 160 countries as a Party to the international treaty known as the [Montreal Protocol](#). All developed countries agreed to phase out production of most ozone-depleting substances, including CFCs, by the end of 1995. The 1990 Clean Air Act Amendments (the Act) incorporated this production ban date and directed EPA to develop regulations to maximize recycling, ban [nonessential uses](#), develop [labeling requirements](#) and examine [safe alternatives](#) for ozone-depleting substances.

#### Impact of Motor Vehicle Air Conditioners

One of the largest uses of CFC-12 in the U.S. is as a refrigerant in motor vehicle air conditioners (MVACs). [Section 609](#) of the Act gives EPA the authority to establish requirements to prevent the release of refrigerants during the servicing of MVACs and to require recycling of refrigerants. Widespread refrigerant recycling reduces the demand for virgin CFC-12 and thus extends the time that it will be available. The following sections describe the requirements of the law and its potential impact on the service industry.

#### Recycling vs. Reclamation

In the discussion below, recycling means the use of a machine to remove impurities and oil and then recharge the refrigerant into either the same car or a different car. Recycled refrigerant is not as pure as reclaimed refrigerant. Recycling occurs in the service shop.

Reclamation means the removal of all oil and impurities beyond that provided by on-site recycling equipment, and reclaimed refrigerant is essentially identical to new, unused refrigerant. Reclamation cannot be performed in the service shop. Rather, the shop generally sends refrigerant either back to the manufacturer or directly to a reclamation facility.

Reclamation means the removal of all oil and impurities beyond that provided by on-site recycling equipment, and reclaimed refrigerant is essentially identical to new, unused refrigerant. Reclamation cannot be performed in the service shop. Rather, the shop generally sends refrigerant either back to the manufacturer or directly to a reclamation facility.

### ***Handling CFC-12***

#### Venting CFC-12

Another section of the Clean Air Act, [section 608](#), prohibits releasing CFC-12 into the atmosphere. The [prohibition on venting CFC-12](#) has been in effect since 1992.



### Section 609 Regulatory History

The original regulation promulgated under section 609 was published in July 1992. That regulation established standards for equipment that [recovers](#) and [recycles](#) CFC-12 refrigerant from motor vehicle air conditioners, rules for training and testing technicians to handle this equipment, and record-keeping requirements for service facilities and for refrigerant retailers. A [supplemental final rule](#) published in May 1995 established a standard for equipment that recovers but does not recycle CFC-12, and training and testing technicians to handle this equipment.

### Approved Equipment

Technicians repairing or servicing CFC-12 MVACs must use either [recover/recycle](#) or recover-only equipment [approved by EPA](#). Recover/ recycle equipment cleans the refrigerant so that oil, air and moisture contaminants reach acceptably low levels.

### Technician Training and Certification

Technicians who repair or service CFC-12 motor vehicle air conditioners must be trained and certified by an [EPA-approved organization](#). Training programs must include information on the proper use of equipment, the regulatory requirements, the importance of refrigerant recovery, and the effects of ozone depletion. To be certified, technicians must pass a test demonstrating their knowledge in these areas. A list of approved testing programs is available from the Hotline and the web site listed above.

### Recordkeeping Requirements

Service shops must maintain records of the name and address of any facility to which refrigerant is sent. If refrigerant is recovered and sent to a reclamation facility, the name and address of that facility must be kept on file. Service shops are also required to maintain records (on-site) showing that all service technicians are properly certified.

### Certification Requirements

Service shops must certify to EPA that they have acquired and are properly using approved refrigerant recovery equipment, and that each person using the equipment has been properly trained and certified. The certification statement shall include the name and address of the service establishment, the name of the equipment manufacturer, equipment model and serial number, and equipment date of manufacture. A sample [certification form](#) shows the information that should be included in the signed statement.

### Sales Restrictions

Section 609 has long prohibited the sale of small cans of ozone-depleting refrigerants to anyone other than a certified technician. The sale of any size container of CFC-12 to anyone other than certified technicians was prohibited under section 608 of the Act beginning on November 14, 1994. This provision is intended to discourage "do-it-yourselfers" who recharge their own air conditioners. Such individuals often release refrigerant because they typically do not have access to recovery/recycling equipment. The Agency encourages "do-it-yourselfers" to bring their cars to certified technicians who can properly fix air conditioners using approved equipment. This avoids damage to A/C equipment by improper charging and helps to protect the environment.

## ***Handling HFC-134a***

### Venting HFC-134a Refrigerant

Section 608 of the Clean Air Act prohibits releasing [HFC-134a](#) into the atmosphere. The [prohibition on venting HFC-134a](#) has been in effect since November 1995.



### Section 609 Regulatory History

In [March 1996](#), EPA proposed a rule to require recycling of HFC-134a. The rule proposed standards for recover-only and recover/recycle equipment and rules for training and testing technicians to handle this equipment. EPA requested comments from the public about this proposed rule, and, after reviewing the comments, published a final rule on December 30, 1997. This final rule will become effective on January 29, 1998. For more information about this rule, see the fact sheet "[Summary of Final Rule Governing Substitutes for CFC-12 Refrigerant in Motor Vehicle Air Conditioners](#)" available through the Hotline and the web site.

### Approved Equipment

Technicians who repair or service HFC-134a MVACs must recover the refrigerant and either recycle it on-site, or send it off-site to a reclamation facility so that it may be purified according to ARI Standard 700. Technicians must use EPA-approved equipment to perform the refrigerant recovery and recycling. Recover/ recycle equipment cleans the refrigerant so that oil, air and moisture contaminants reach acceptably low levels. A list of approved recover/recycle and recover-only equipment is available from the Hotline and the web site listed above. Note that certain EPA-approved models can recycle both CFC-12 and HFC-134a refrigerants.

### Converting CFC-12 Equipment for Use with HFC-134a

EPA regulations prohibit technicians from changing fittings on the same unit back and forth so that the unit is used for CFC-12 in the morning, HFC-134a in the afternoon, then back to CFC-12 again, etc.

EPA regulations specify that when equipment is converted for use with a new refrigerant, the converted unit must be able to meet the applicable equipment standard set forth in the regulations. CFC-12 equipment may be permanently converted for use with HFC-134a under certain conditions. EPA intends to issue regulations placing certain restrictions on these retrofits in the future. Those restrictions may require that the manufacturer's service representative rather than the automotive service technician perform the retrofit, that a unit may only be retrofitted if retrofit procedures have been certified by an independent testing laboratory such as Underwriters Laboratories, and that an appropriate label is affixed to the unit. In addition, the retrofitted unit must meet the technical specifications of SAE standard J2210 and must have the capacity to purify used refrigerant to SAE standard J2099 for safe and direct return to the air conditioner following repairs.



Currently, however, in the absence of any EPA regulations, a service facility may perform such a retrofit, or may have the equipment manufacturer's service representative perform the retrofit, as long as the fittings are changed in accordance with EPA's Significant New Alternative Policy (SNAP) program regulations. The Agency cautions technicians, however, that even though recovering a given refrigerant using permanently converted equipment is legal, it may not be technically desirable. The equipment is designed to be compatible with specific refrigerants, and incompatible materials may cause short circuits, damage to seals, and compressor failure. Technicians should check with the recovery equipment manufacturer for recommendations about the recovery of refrigerants other than the refrigerant the equipment was originally intended to recover. Conversion of recovery equipment for use with other refrigerants may also invalidate any warranties offered by the equipment manufacturer.

#### Technician Training and Certification

Technicians who repair or service HFC-134a MVACs must be trained and certified by an [EPA-approved organization](#). If a technician is already trained and certified to handle CFC-12, he does not need to be recertified to handle HFC-134a.

#### Recordkeeping Requirements

Service shops must certify to EPA that they own approved HFC-134a equipment. Note that this certification is a one-time requirement, so that if a shop purchased a piece of CFC-12 recycling equipment in the past, and sent the certification to EPA, the shop does not need to send a second certification to EPA when it purchases a second piece of equipment, no matter what refrigerant that equipment is designed to handle. If refrigerant is recovered and sent to a reclamation facility, the shop must retain the name and address of that re-claimer.

#### Sales Restrictions

Right now, there is no restriction on the sale of HFC-134a, so anyone may purchase it. This year, EPA will issue a proposed rule under section 608 of the Act that will include a proposal to restrict the sale of HFC-134a so that only technicians certified under sections 608 and 609 may purchase it. After the proposed rule is published, EPA will review comments from the public on the proposal and will then publish a final rule sometime in 1998 or 1999.

#### ***Retrofitting Vehicles to Alternative Refrigerants***

Although [section 609](#) of the Act does not govern retrofitting, [section 612](#) of the Act, which describes the Agency's Significant New Alternatives Policy ([SNAP](#)) program, does require that when retrofitting a CFC-12 vehicle for use with another refrigerant, the technician must first extract the CFC-12, must cover the CFC-12 label with a label that indicates the new refrigerant in the system and other information, and must affix new fittings unique to that refrigerant. In addition, if a technician is retrofitting a vehicle to a refrigerant that contains R-22, the technician must ensure that only barrier hoses are used in the A/C system. Finally, if the system includes a pressure relief device, the technician must install a high-pressure compressor shutoff switch to prevent the compressor from increasing pressure until the refrigerant is vented. Much more information about the SNAP program and about retrofitting procedures is available in a fact sheet called [Choosing and Using Alternative Refrigerants](#).

## Unit 2: EVALUATING AND DIAGNOSING A/C SYSTEMS

### Chapter 1: Primary Causes – What Can Go Wrong?

Some A/C performance problems are caused by malfunctioning or broken components. Others, such as system leaks and improper service procedures can be the root causes of many customer performance complaints.

#### Refrigerant Leaks

Refrigerant charge level is critical to proper system performance. Any loss of refrigerant will result in reduced cooling capacity. Modern A/C systems have R-134a refrigerant capacities as low as one pound (450 grams). As a result, even a small loss of charge can have a big effect on passenger comfort.

Service ports and caps are the most common source of refrigerant leaks. While service port caps are not the primary seal (the Schrader valves are) the caps do serve as a secondary line of defense against service fitting leakage. They are sealed with O-rings in R-134a systems, and are designed to contain any refrigerant that seeps past the service valve core. They also protect the valve core assembly from dirt and moisture contamination. Up to a pound of refrigerant per year can escape from a service port if the cap is missing.



Other leak sources include worn or brittle (old) hoses, loose fittings or connections, improper seals, and damaged components. Component malfunctions will be discussed in detail shortly.

A low charge level doesn't just reduce the system's cooling capacity; it can also cause compressor oil starvation. Because oil is circulated inside an A/C system by being suspended in the refrigerant, operating an undercharged A/C system can cause compressor seizure. Studies have shown that as little as a 10% to 20% undercharge, which can be as little as 3 ounces (85 grams), can cause oil circulation to decrease by as much as 80%.

#### Air Contamination

Leaks cause air to be drawn into the system as ambient and system temperatures drop. Air can also enter the system through careless service procedures, such as improper refrigerant recovery, insufficient evacuation, or by not purging air from gauge hoses or charging lines. Because a system contaminated with air operates with less efficiency, cooling capacity is reduced.

Earlier in this course, we discussed the pressure / temperature relationship of R-134a refrigerant. As system temperatures rise and fall, so do refrigeration system pressures. Unlike refrigerant, air is non-condensable, meaning that it cannot be completely changed from a gas to a liquid state. As a result, air contamination of refrigerant can cause excessive A/C system temperatures and pressures.

### The Effects of High Temperature and Pressure

High system temperatures can start a chain of harmful reactions. Just a 15° F (8.3° C) increase in temperature doubles the chemical reaction rate inside an A/C system. The lubricating oil may oxidize into gum and varnish, which can cause compressor bearings to seize. High temperatures can also cause the refrigerant itself to begin to break down. An excessive heat load can cause synthetic rubber parts to become brittle and susceptible to cracking.

The pressure increase that comes along with heat can cause weakened parts to rupture. Also, as the temperatures and pressures become excessive, the stress and strain on compressor reed valves may cause them to break.

### Moisture Contamination

As air enters the system, so does moisture. Although excessive system temperatures and pressures are responsible for many refrigeration system failures, the presence of moisture always accelerates corrosion and system failure. Moisture is the greatest enemy of a refrigeration system.

The presence of moisture can cause internal system corrosion in the form of either iron or aluminum hydroxide. Moisture also causes decomposition of the refrigerant and lubricating oil. When combined with refrigerant, moisture can form hydrochloric or hydrofluoric acid, which accelerates corrosion-related component failure.

Excessive system moisture can also cause TXV or Orifice Tube icing and restriction, with erratic system operation or poor system performance being the result.

### Other Contaminants

Dirt, flushing agents or cleaner residue, soldering fluxes, metal chips and even cloth lint in an A/C system can be damaging as well.

Dirt contamination is abrasive, which causes premature component wear. Dirt can also clog internal screens and orifices. Some types of dirt can also cause chemical reactions with refrigerant, oil, and other system materials.

Metal particles in an A/C system can also have some of the same effects as dirt contamination. Any foreign materials introduced into the A/C system can cause seized compressor bearings, broken discharge reeds, and expansion valve or orifice tube failure.

Aftermarket A/C sealants work by reacting with moisture. In systems with high levels of air or moisture, sealants can produce clumps that can clog components and restrict refrigerant and oil flow.

Flushing agents can dilute the oil in an A/C system, and can also cause adverse chemical reactions. Unapproved solvents can be combustible, and their use in an A/C system can cause a fire or explosion. Never flush out an A/C system with a flammable solvent.

An A/C system can also be contaminated by mixing different types of refrigerants. The best bet for any technician when servicing or evaluating any automotive A/C system is to obtain as much of the previous vehicle service history as possible. Also, always start your evaluation and diagnosis of every vehicle A/C system by using a refrigerant identifier. An identifier will tell you immediately how much air and impure or mixed refrigerant is in the system.

Using factory service procedures and being careful and clean can keep contamination to an absolute minimum. General A/C service practices and procedures will be covered in detail shortly.

### **Component Malfunction Symptoms**

Malfunctions in the refrigeration system can occur with the compressor, condenser, evaporator, orifice tube or thermostatic expansion valve, receiver-drier or accumulator-drier, and the compressor controls. Restrictions in lines and hoses reduce refrigerant flow and cooling capacity, as does an inadequate or lost charge of refrigerant.

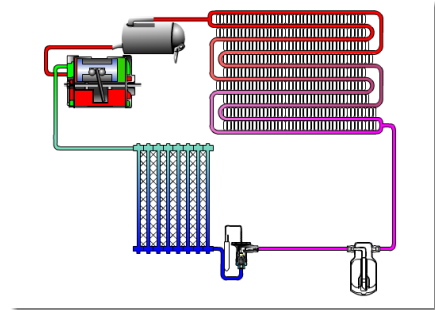

### **Compressors and Clutches**

Compressor malfunctions show up as:

- Noise
- Seizure
- Leakage
- Low inlet and discharge pressures

Some compressor noises during A/C operation are normal. A/C systems sometimes use a muffler assembly to dampen compressor vibrations.

Always check compressor mounting brackets and hardware for missing or broken pieces when evaluating a compressor noise complaint. In some cases, loosening and re-torquing compressor mounting hardware to factory specifications can cure a noise problem. Irregular noises or rattles, however, are likely indications of broken internal compressor parts.

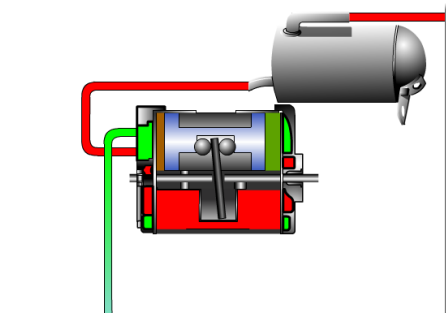

To check for compressor seizure, try to rotate the drive plate either by hand or with a wrench with the engine off. If the drive plate cannot be easily rotated, the compressor is most likely seized. A burnt or broken drive belt or a burnt drive plate can be another sign of compressor seizure. This may be caused by insufficient lubrication, inadequate condenser airflow or by system contaminants. The root cause of the failure must be found and corrected. Simply replacing the seized compressor and hoping for the best will likely result in a comeback.

If a compressor clutch is inoperative, but the compressor itself not seized, verify that system voltage is present at the clutch terminals or compressor control relay when A/C is requested. You can also try using fused jumper leads to energize the compressor clutch directly from the vehicle battery. Excessive resistance in the compressor clutch control circuit can reduce the strength of the clutch magnet and cause slippage.

There are many different types of compressor control systems. Vehicle manufacturers provide specific A/C system diagnostic charts and procedures for each of their products. These should always be referred to during system diagnosis and repair because of the many changes that may occur by vehicle model, manufacturing year, or A/C system content and configuration.

Compressor leakage may be caused by defective seals. Sometimes, refrigerant leaks will cause oil staining on the compressor body or clutch.

Low compressor discharge pressure may be caused by a faulty internal seal or even a restriction inside the compressor. Restrictions elsewhere in the system or simply a too-low charge of refrigerant may cause low refrigerant pressures on both the low and high pressure sides of the system. These possibilities should be checked prior to removing the compressor for service or replacement.

#### A Note on Variable Displacement Compressors

Problems with variable-displacement compressors can be more difficult to diagnose than problems with cycling clutch compressors. The output of this type of compressor is so variable that even a plugged expansion valve will hardly change system pressures. Also, a stuck-open compressor control valve will allow so much pressure into the crankcase that refrigerant flow will almost stop. The compressor may not seem to be running when gauge pressures are so low.

Again, refer to published service information for specifics when diagnosing problems with a Variable Displacement Compressor. As a general rule, if gauge pressures are low then the compressor should be considered at fault only after eliminating a plugged expansion valve and stuck-open compressor control valve.

### **Condensers and Evaporators**

Condenser problems fall into three categories:

- Leaks
- Refrigerant flow restrictions
- Airflow restrictions

Condenser leaks may develop from internal or external corrosion or from punctures to the refrigerant passages. Obviously, a leaking condenser will fail to perform properly and may shut down the system as the refrigerant is lost. If the leak is slow, oil starvation may seize the compressor first.

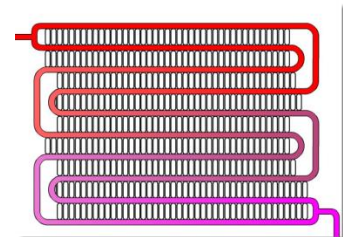

Refrigerant flow restrictions are usually caused by excessive corrosion or contaminants in the system. Debris from a failed compressor can block or restrict the flow of refrigerant. Trapped air can also block refrigerant flow. Such restrictions will result in excessive compressor discharge pressures.

Keep in mind that excessive compressor discharge pressures can only be seen on the high side gauge if the high side service port is located on the compressor discharge line between the compressor and the condenser.

If the high side service port is located on the liquid line between the condenser and the orifice tube or expansion valve, the high side gauge will read low when refrigerant flow through the condenser is restricted.

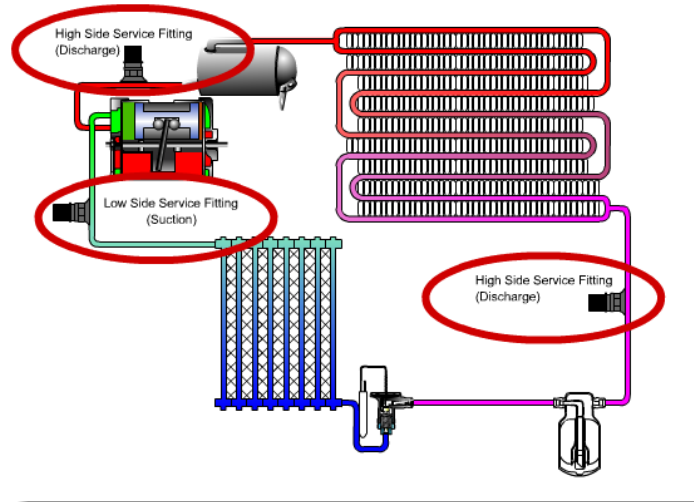

Inadequate condenser airflow is another potential component-related cause of excessive system temperatures and pressures. Engine cooling fans are a critical part of an air conditioning system. Cooling fans that are inoperative, or that do not work properly will reduce heat transfer from the condenser. Obstructions, missing seals or damaged air intake shrouds will also reduce airflow. Without sufficient cooling air for refrigerant condensation and heat transfer, refrigerant temperatures and pressures will stay high. This may overwork the compressor and generally reduce refrigeration system performance.

### Evaporators

Like the condenser, the evaporator is also a heat exchanger. Potential evaporator problems fall into two categories:

- Leaks
- Airflow restrictions

Evaporators, unlike condensers, rarely have problems with refrigerant flow restriction. Their passages are generally larger in diameter than condenser passages. Evaporators are not subject to the same pressure and temperature extremes as condensers, plus they are downstream from the TXV or orifice tube. TXV and orifice tube screens will, in most cases, keep trash out of the evaporator passages.

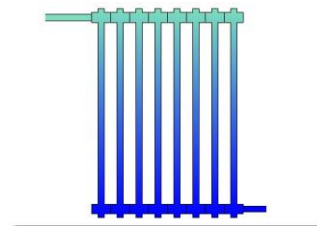

Refrigerant leaks may develop from internal or external corrosion. Many times, the evaporator case will collect leaves and trash which hold moisture and accelerate corrosion failure. Because of the evaporator's location, leaks caused by physical damage are rare unless the vehicle has been involved in a collision.

Evaporator core and case problems often show up as an inadequate supply of cooled and dehumidified air. This symptom is usually the result of a dirt-plugged core, a cracked evaporator case, or leaking seal. Air distribution system problems can also cause improper vent temperatures or low airflow through the vents.

An inoperative or malfunctioning blower motor affects evaporator heat transfer efficiency. The blower speed directly affects the evaporator heat exchange rate.

Low airflow and poor cooling can also be caused by evaporator freeze-up. Condensed moisture that collects on the evaporator surface can freeze the core and restrict both airflow and heat absorption. Freeze-ups can be caused by compressor clutch control circuit problems. A low refrigerant charge or excessive amounts of air in the system can freeze the evaporator as well.

## Restrictions

### Orifice Tubes

Orifice tube restriction is often indicated by low gauge pressures and insufficient evaporator cooling. The section of line where the orifice tube is installed may frost as well. The usual cause of the restriction is a clogged orifice tube screen.

It is recommended that the orifice tube be examined whenever an A/C system is discharged. This is not always possible in situations where the orifice tube is crimped into the liquid line. Look to see if there are any pieces of foreign material stuck on the screen.

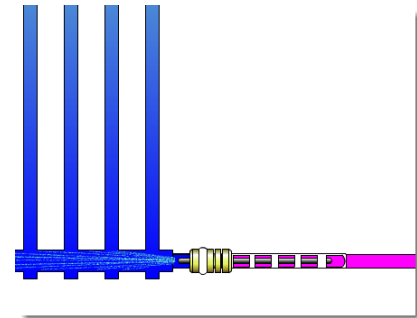

If the blockage looks like gray or brown powdery material, the cause is probably a ruptured desiccant bag in the receiver-drier or accumulator-drier. If the screen blockage looks like shiny metal chips, the compressor may be failing. Hose residue in the form of black granular material can also clog the screen. This is usually caused by moisture in the system, which reacts with the refrigerant to form acid. The acid in turn breaks down hoses and seals.

Examining the orifice tube will give a rough indication of system oil level in some cases as well. Note that this is not a definitive check of system oil level, but an indication. An orifice tube that comes out dripping wet with oil may be a sign of too much oil in the system. A bone dry orifice tube may be a sign of too little oil. If the quantity of oil on the orifice tube looks like it was lightly sprayed on, meaning that the tube is lightly coated but not dripping wet, then the indication is that the system oil level is close to correct.

Previous A/C system service records can be very important. If an orifice tube has been installed that is too small for the system, high side pressures will increase and the compressor may be cycled on and off too quickly for efficient cooling. If the orifice is too large, or if the orifice tube O-Rings do not seal the tube tightly against the inside of the line, the compressor may never cycle off.

### Thermostatic Expansion Valves

TXV restrictions are usually indicated by the same symptoms as those for a restricted orifice tube - low gauge pressures and insufficient evaporator cooling.

Like the orifice tube, TXV inlet and outlet screens can also become plugged due to system contaminants. A plugged TXV must be cleaned or replaced.

Some TXV designs use an external temperature sensing bulb to regulate refrigerant flow. This bulb is normally clamped to the evaporator outlet line and wrapped with insulating tape. If the bulb is not firmly clamped in place or properly insulated, the TXV can open too far. A TXV that opens too far or is stuck open will cause cycling clutch compressors to never cycle off. Low side pressures and vent temperatures will also be higher than normal.

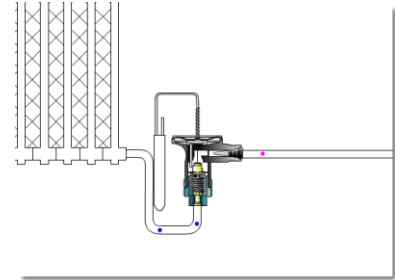

### *Receiver-Dryer or Accumulator-Dryer*

Both of these driers perform similar functions, as previously described.

The most common drier failure is a ruptured desiccant bag. The main cause of desiccant bag rupture is moisture contamination of the system. As we noted earlier, moisture in an A/C system forms acid, which can destroy the desiccant bag and cause loose desiccant to circulate through the system. If orifice tube or TXV clogging indicates loose desiccant in the system, the drier should be replaced.

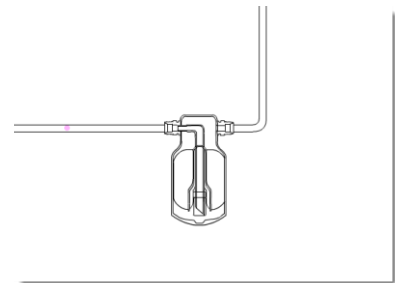

Either unit must also be replaced if certain malfunction symptoms are evident. Compressor oil starvation may indicate a clogged oil bleed hole on an accumulator-drier. Evaporator refrigerant starvation, which will give low gauge readings, may indicate blockage in a receiver-drier. Some blocked or restricted receiver-driers will frost over, which can be yet another indication of a problem.

Note that the desiccant can become saturated with moisture over time. Once saturation is reached, no more moisture can be absorbed. Refrigerant leaks can also occur as a result of perforations, damaged O-ring seats or damaged fitting threads.

## **Chapter 2: A Diagnostic Plan**

Now that we know what some of the most common component malfunction systems are, we can discuss a diagnostic plan, which is a method that will give a systematic approach to diagnosis. To assist us in our diagnosis, we can also use worksheets to help us throughout the process. The first is the System Diagnostic Worksheet and it will be used throughout our diagnosis. The Diagnostic worksheet is included as an addendum to this eBook (found at the end of this document).



### ***Step Two: Verifying the Complaint***

During this step, the technician should review the customer complaint worksheet while operating the vehicle and the A/C system under the conditions described in the worksheet to see if the customer's complaint is repeatable and valid. This may require taking a test drive. Though intermittent problems may be difficult to duplicate, verification should enable the technician to experience the customer complaint firsthand in most cases.

#### A Note on Normal Operation

Some A/C operating conditions may cause complaints from vehicle owners when the system is actually operating as designed. Under conditions of high humidity, a vehicle owner may complain that air from the vents doesn't feel as cold as expected. Heat energy does not transfer as readily or efficiently from humid, moisture-laden air. The moisture itself not only contains additional heat energy, but also holds heat in the air more effectively. As a general rule, most modern automotive A/C systems should produce vent temperatures at least 20° F (7° C) cooler than outside ambient temperatures. In some cases, this is all that can be expected from a properly operating system in extreme conditions.

A/C systems that use a cycling clutch compressor can cause some slight increases and decreases of engine speed and power which are noticeable under some vehicle operating conditions. This, too, is normal and indicates that the system is cycling to maintain full cooling capacity while preventing evaporator freeze-up.

If the engine is turned off with the system operating, refrigerant will flow from the high-pressure side through the orifice tube or TXV until system pressures are equalized. The hissing sound that occurs during this equalization of system pressures is normal, as well. These are all examples of normal operating conditions that may require an explanation to the vehicle owner. Once the customer concern has been verified as a real system operating problem, the service technician can begin diagnosing the cause.

### ***Step Three: Visual A/C System Inspection***

Diagnosis should start with a visual system inspection. This may quickly reveal an obvious cause of the customer complaint and system performance problem. It may also reveal other problems about to occur.

The first item to verify is A/C compressor engagement. Whether or not the compressor clutch is activated when A/C is requested at the control panel is a crucial item that will determine a diagnostic direction. When diagnosing a vehicle equipped with electric cooling fan, make sure that the fan comes on whenever the compressor clutch is engaged.

If the compressor does not engage when commanded, connect a manifold gauge set to see if there is any pressure in the refrigeration system. If no pressure exists, look for signs of a large, obvious refrigerant leak. Visual clues that indicate the presence of a large leak may include broken, physically damaged, or oil-stained hoses, pipes, or components. Broken or damaged components will obviously need to be repaired or replaced. The A/C system will then need to be made to operate before any other diagnostics can be performed.

Additionally, it is a good idea to check the wiring and connectors for excessive wear, loose or damaged connections, or incorrect routing during this visual inspection. Also make note of the condition of the condenser and radiator fins. If they are damaged or filled with debris, they will restrict airflow and cause the AC system to operate inadequately.

If the compressor does not engage, but the gauges show that the system has static pressure, note the amount of pressure. When using US units of measure, R-12 and R-134a both have about a 1 psi per 1° F pressure / temperature relationship at ambient temperatures. This means that, if the ambient temperature is 80° F, both the low and high side gauges should read over 80 psi if the system has a full charge.

When using metric units of measure, the R-12 and R-134a pressure / temperature relationship at ambient temperatures is about 20 kPa per 1° C. This means that, if the ambient temperature is 27° C, both the low and high side gauges should read over 609 kPa. This method is not exact, and is not intended to substitute for use of R-12 and R-134a pressure / temperature relationship charts. It will however assist technicians in estimating the charge level of a non-functioning system.

If static pressures indicate that the system has close to a full charge, refer to manufacturer-specific repair information to diagnose the cause of “No Compressor Clutch Engagement”. As noted earlier in this section, vehicle manufacturers provide specific A/C system diagnostic charts and procedures for each of their products. Always refer to these charts during system diagnosis and repair because of the many changes that may occur between vehicle models, manufacturing years, or A/C system content and configuration.

If static pressures are low, chances are good that there’s a leak. The leak will need to be found and repaired. The A/C system will then need to be made to run before any other diagnostics can be performed.

If the gauges show any pressure at all, or, if the compressor engages when commanded, proceed with checking for the presence of sealant in the system and refrigerant analysis before any further diagnosis is done.

#### ***Step Four: Check for Sealants***

The first test that should be performed is sealant detection. A detector such as the Snap-on® ACT700 A/C sealant detector should be used on every vehicle prior to connecting any other equipment.

Aftermarket A/C sealants are found in more vehicles each year. These sealants are designed and marketed to both repair shops and the general public as an economical method of repairing A/C system leaks. A/C sealants are installed into the system as a liquid, and are designed to solidify in the presence of air and moisture.

Because sealants are liquids, they can clog and damage A/C components, a refrigerant identifier, or an A/C recovery / recycling machine. Snap-on and other A/C equipment or component manufacturers will not warranty any equipment or components damage caused by A/C sealants. Sealant detection will be discussed further in the next section, Refrigerant System Service.



#### **Step Five: Refrigerant Analysis**

The next test should be refrigerant analysis and identification. Prior to recovering or charging refrigerant system, you must use an A/C Refrigerant Analyzer to identify gas samples taken directly from the refrigeration system or storage containers. Like aftermarket A/C sealants, alternative refrigerants and mixtures of different types of refrigerants are found in increasing numbers of vehicles each year. If no sealant is detected in the system, the Snap-on® ZEEAC312C Refrigerant Identifier should be used to determine the concentrations of R-12, R-134a, R22, flammable hydrocarbons and air in the system. This is essential information for both safety and diagnostic reasons.

When used properly, this Refrigerant Analyzer will display one of the following; R-12 or R-134a if the sample is at least 98% by weight or FAIL if neither gas is detected or if the concentration is not at least 98%. Likewise, it will display HC and a horn will sound if a flammable hydrocarbon is detected.

Procedures for using a Refrigerant Identifier and refrigerant identification testing are covered in the next section, Refrigerant System Service.

If the refrigerant fails the analysis, discontinue diagnosis and make recommendations for repairs. If it passes, continue on to the AC Quick Check.

**CAUTION:** If contaminated refrigerant is detected, DO NOT recover the refrigerant into your recovery/recycling equipment. Instead, recover the contaminated refrigerant using suitable recovery-only equipment designed for capturing and storing contaminated refrigerant. For additional information, refer to the next section.

### ***Step Six: Testing for Refrigerant Leaks***

Conduct an Insufficient Cooling Quick Check, checking the system for an adequate, but not excessive, refrigerant charge.

Note: This Quick Check is for Cycling Clutch Orifice Tube (CCOT) systems only. CCOT systems have fixed displacement compressors that normally shut off once a certain low or high side pressure is reached. Variable Displacement compressor systems (VDOT) will use a different Quick Check since they are designed to shut off only if a system fault has occurred.

#### Insufficient Cooling - Quick Check

Very often, this particular test is performed as part of an A/C system visual inspection. That is because it can help service technicians quickly determine whether or not the system has an adequate, but not excessive, charge of refrigerant. It can also be used to eliminate a low refrigerant charge as the cause of an A/C system performance problem.

The following procedures are for a typical CCOT refrigeration system used on General Motors vehicles. The same general principles apply to other system types as well. One prerequisite for accurate test results is that the ambient temperature must be above 21°C (70°F). Otherwise, system cooling may not be sufficient for desired results. To perform this check:

- Ensure that the engine is warm and operating at normal idle speed.
- Open the hood and all body doors.
- Position the HVAC system mode selector on NORM (system variable).
- Set the desired temperature to COLD.
- Place the blower motor/fan switch on HIGH.
- When the compressor is operating, feel the evaporator inlet tube after the orifice tube. Then, feel the surface of the accumulator.
- Compare the temperature of the inlet tube to that of the accumulator.
- Proper system operation is indicated if both feel much colder than the ambient air, and if both feel about the same temperature.
- If the inlet pipe is cooler than the accumulator surface, or if the inlet pipe has frost accumulation, a low refrigerant charge is indicated.

If a low refrigerant charge is indicated, carefully check the system for leaks using a halogen leak detector. DO NOT charge the system until the leak has been repaired. With older, high-capacity systems, a low charge condition may be corrected by adding small amounts of refrigerant until both surfaces feel the same temperature. Allow the system to operate and stabilize between each addition. On some systems, an additional small amount of refrigerant must be added even after the temperatures feel the same. With newer systems, recovery and recharging with the specified amount of refrigerant is recommended. Leak detection will be covered in detail in the next section.

### ***Step Seven: Functional Check***

A functional check is a very straightforward series of tests used to check for the “operability” of our A/C system. With the vehicle in park and with the parking brake set, start the engine and turn A/C system to MAX A/C with the blower on high. Then we check to make sure the compressor has engaged and is running, that the condenser fan and coolant fan are operating, the blower motor is functioning on all speeds, and that the air changes from panel to floor to defrost as the control is moved through its positions. While the air is being diverted between positions, we also need to move the temperature control to check for changes in the vent temperature. If one or several of these tests fail, the problem area should be rather obvious and easy to identify. If they all check out, then the problem is one of performance and requires a performance test.

In addition, if the vehicle is equipped with Electronic Automatic Temperature Control (EATC), it is a good idea to run a diagnostic check of its systems at this time to determine that it hasn't failed and is operating properly.

### ***Step Eight: Performance Test***

The Performance Test can provide diagnostic technicians with a measure of the air conditioning system's operating efficiency. To accomplish this, system pressures for both the high-side and low-side of the refrigeration system and the temperature of the air being discharged into the passenger compartment are measured and compared with system specifications for different ambient air temperatures and relative humidity levels.

Equipment required for this test includes a manifold gauge set (stand-alone or on a Recharge unit) and a precision thermometer. Performance test results for a typical CCOT system are shown here, while readings for a typical VDOT system are provided here. Test procedures include:

- Perform an HVAC system Functional Check first.
- Open the vehicle hood, keep all doors and windows closed when measuring the system discharge and air temperatures.
- Connect the gauge set into the system. The high-pressure gauge is connected to the high-side service fitting on the compressor to condenser line. The low-pressure gauge is connected to the low-side service fitting on the accumulator. Both gauge valves should be closed, while making these connections. The center hose fitting on the gauge set must also be closed and remain closed during testing.
- Set the temperature control to 16° C (60° F), mode to AUTO, and blower motor/fan speed to HIGH. This may vary according to control strategy.
- After idling the engine for five minutes, increase the engine speed to 1,200 rpm for the actual system performance test.
- Before taking performance test readings, determine the temperature and relative humidity of the air being blown against the condenser.
- Measure the temperature of the discharge air from a center instrument panel outlet and record the system high-side and low-side pressures.

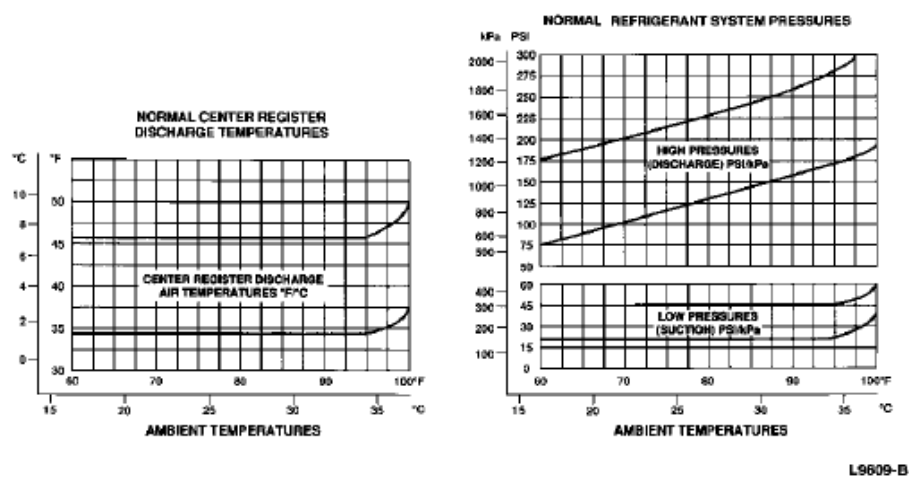

Compare the discharge air temperature and system pressures with the Performance Test chart data for the specific vehicle make and model. If the operating temperatures and pressures are within the normal range for the specific vehicle, the refrigeration system is operating properly. Slight variations are considered acceptable. Out-of-spec readings may indicate low refrigerant, component malfunctions, or restrictions in the system.

Also at this time we can perform a "feel" test of the system. If we touch the line between the compressor and the condenser (fig. 1), it should be hot since this is the high-pressure vapor line. This area should be the hottest in the system.



Touching the high-pressure liquid line between the condenser and the restriction (fig. 2) should be warm since heat has been removed from the refrigerant in the condenser.

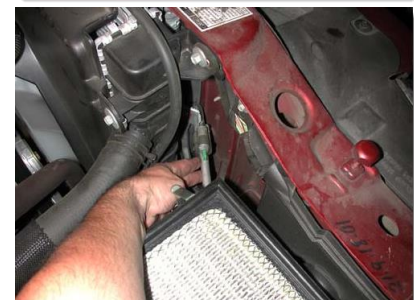

The section from the restriction to the evaporator (fig. 3) will be the coldest line (low-pressure liquid) and the evaporator to compressor line (fig. 4) will be the next coolest line since it has absorbed some heat from the evaporator. This "feel" test will not provide us with actual values concerning pressures and/or temperatures, but it is another useful way of helping to locate system faults by determining which parts of the system are not operating as designed.





### Diagnosing Orifice Tube HVAC Systems

A/C service technicians should always refer to the appropriate diagnostic guidelines for the specific vehicle model and HVAC system type. Normal system operation as well as problem symptoms can vary widely between vehicles and specific system configurations. A diagnostic chart for a typical orifice tube (OT) HVAC system is shown here. This system uses a cycling clutch compressor, as in the CCOT refrigeration systems used on some GM vehicles. Diagnosing VDOT systems will have some differences.

### Diagnosing Expansion Valve HVAC Systems

A diagnostic chart for a typical expansion valve (TXV) HVAC system is shown here. The system used for these sample diagnostic guidelines has a cycling clutch compressor, as in the CCTXV refrigeration systems used on some GM vehicles. Diagnosing VDTXV systems will have some differences.

TXV function can sometimes be tested by using ice to chill the sensing bulb with the A/C system running. The low-side pressure should drop to a vacuum when the bulb is chilled below 32° F (0° C). Once the ice is removed and the bulb's temperature rises, the low-side pressure should increase back to normal. If not, the TXV is most likely defective.

The Receiver-Dryer is found on TXV systems. It will be located in the liquid line between the condenser and the TXV. The accumulator-dryer is found on Orifice Tube (OT) systems. It will be located in the vapor line between the evaporator outlet and the compressor.

### ***Step Nine: Related Subsystem Diagnosis***

When diagnosing an A/C complaint it is important to not overlook other areas that may affect the operation of the A/C system. Some of the areas to be aware of include:

#### Engine Cooling System

- Coolant pumps
- Low coolant level
- Heater hose problems
- Accessory drive belts
- Fans inoperative

### Airflow

- Debris in the radiator and/or condenser that prevents proper engine cooling.

### Air delivery to the blower

- Leaves, pine needles, etc. that block the air
- Clogged filter to the blower system

### Engine Control Computer

- May keep system turned off due to a failure code or operating condition such as Wide Open Throttle.

### Automatic transmission

- On some systems, Auto trans overheating will keep the A/C disabled because the transmission fluid is cooled in the radiator and the transmission takes priority over the A/C system.

## Unit 3: HVAC SERVICE

### Chapter 1: Refrigerant System Service

Some A/C performance problems are caused by malfunctioning or broken components. Others, such as system leaks and improper service procedures can be the root causes of many customer performance complaints.

#### *What's in the System?*

We have seen that a logical, sequential approach is needed for safe, effective A/C system diagnosis and service. After you have done a visual and mechanical inspection confirming a complaint and finding no obvious problems, you will need to do some more investigating. Let's suppose the vehicle's compressor turns on and seems to function normally. You know there's something in the system, or else the low-pressure cutoff switch would prevent the compressor from energizing. You need to know what is in the system, particularly with older cars. Knowing what is in the system is critical for a number of reasons:



- Some refrigerant blends or "replacements" for R-12 contain a flammable hydrocarbon base, such as propane or butane!
- There are A/C system "leak sealers" on the market which may damage system components and recovery/recycling equipment, as well as contaminating refrigerant supplies
- An A/C system may contain other contaminants that can reduce system performance or damage components or equipment and contaminate your refrigerant supplies

Knowing what's in the system can also provide you with other benefits:

- Identifying and labeling refrigerants documents that your shop is handling refrigerant legally. Depending upon the equipment available to you (such as an old recycle/recovery machine dedicated



to recovering contaminated refrigerant to be sent off-site for processing), identifying the refrigerant will let you know if you need to send the customer down the road

- Allows you to document refrigerant purity or contamination for the customer
- A refrigerant identifier allows you to check the purity of refrigerant you purchase
- Can provide a valuable diagnostic tool

## Sealant Detection

### Using a Sealant Detector

As previously discussed, you should first check the system for sealants using a detector such as the Snap-on® ACT700 Sealant Detector. The ACT700 works with either R-12 or R-134a systems. The procedure is performed after running the system for a minimum of two minutes. After shutting off the engine and waiting three minutes, high side pressure is checked. If over 60 psi, the test is done with the engine off; at 60 psi or lower, the engine and system is restarted for the procedure.



The Snap-on ACT700 A/C Sealant detector works by determining if anything in the refrigerant can plug a small flow path that has been wetted with plain water. The detector consists of a fitting attached to the high-side service port. This fitting holds a sensing plug which is drilled with a small, twisty flow path for the refrigerant to flow through.



A flow meter is connected to the outlet of the fixture with a short length of neoprene hose. After wetting the sensing plug and connecting the sealant detector, the technician watches the flow meter for three minutes. The flow rate will rise to a peak in about 60 seconds as refrigerant pressure pushes the water through. Remember, A/C sealants are designed to solidify in the presence of water. This means that a drop in refrigerant flow rate of more than 30% from that peak after another two minutes indicates that the sensing plug is being restricted by sealer in the system.

Used sensing plugs are discarded after use; other parts, including the flow meter, can be cleaned. The amount of refrigerant loss during the testing is insignificant, and within EPA-legal guidelines for testing. Refer to the operating instructions for further details on using the kit.

At the present time, there is no practical, OEM approved method of flushing or removing sealants from an A/C system. Because of the potential for equipment damage, service technicians or service center owners may decline to service a system that contains sealant.

### Impact of A/C System Sealants on Equipment Warranties

- **Snap-on:** "Aftermarket A/C sealants MAY cure within the hoses or internally within the machines causing plaque build up within the hoses, fouling of internal solenoids and or damage to the infrared bench assembly. Users should exercise caution when testing systems containing sealant, as any resulting damage is NOT covered under our standard warranty. Introduction of aftermarket A/C sealants MAY cause damage to Snap-on Refrigerant Identifiers and A/C Diagnostic Tools. This condition is not exclusive to Snap-on and we urge A/C technicians to exercise caution when performing any A/C service using any type of equipment."
- **RTI Technologies:** "RTI recovery/recycling machines are not designed to recover and recycle refrigerant system sealers. The RTI Technologies Warranty may be considered void if evidence of any refrigerant system sealer is found in any of the internal components of an RTI recovery/recycling machine. The owner of a contaminated machine may be advised the warranty is void and all charges for repair will be his responsibility."
- **Delphi:** "Delphi does not approve the use of any type of air conditioning system sealants. The use of any sealant immediately voids all warranties of compressors. If it is determined that the compressor has failed due to the presence or evidence of any sealant, appropriate account adjustments will be made."
- **Visteon:** "Visteon Automotive does not endorse or approve the use of any aftermarket A/C refrigerant system sealer. The use of such aftermarket refrigerant sealers shows evidence of damaging A/C refrigerant recovery/evacuation/recharging equipment, as well as possible damage to A/C refrigerant system components."
- **Mazda:** "Do not use any aftermarket A/C refrigerant system sealer in the repair of Mazda vehicles. The use of such aftermarket refrigerant sealers may result in damage to A/C refrigerant recovery/evacuation/recharging equipment and/or A/C system components."
- Other manufacturers of equipment and components with warranty disclaimers regarding the use of sealers: General Motors, Nissan, Neutronics, Four Seasons Air, NAPA temp Products, Robinair, SKYE.



### Using a Refrigerant Identifier

Once you have established that there are no sealants in the system, the next step is to use a refrigerant identifier to determine the purity of the refrigerant and confirm that there are no flammable blends or other contaminants in the system. Be especially cautious of R-12 systems – they may contain flammable hydrocarbon blends and other so-called "drop-in" replacements for R-12. These refrigerant cocktails may contain R-12, R-134a, R-22, butane, propane, and other chemicals. R-134a systems may contain "boosters" or other additives of unknown composition.



**CAUTION:** Do not introduce these contaminants into your equipment or refrigerant supplies!

If you find a system that is contaminated with flammable blends, be safe. The refrigerant should be recovered using an air-powered recovery machine (does not create sparks) dedicated to recovering contaminated refrigerant. The refrigerant tank should be labeled "contaminated" and sent to a refrigerant recycling center for processing.

A refrigerant identifier will also indicate the presence of another contaminant: air, or "non-condensable gasses." While air is neither dangerous nor harmful, too much air in an A/C system will adversely affect system performance. Fortunately, air can easily be purged from the system during the evacuation and recycling process, provided the recycling equipment and container has been properly purged of air before use. Some refrigerant identifiers can purge air from an otherwise uncontaminated system.

Many refrigerant identifiers simply return a pass/fail result; others will also indicate the refrigerant makeup in percentages by weight.

### Using the Snap-on® ZEEAC312C Refrigerant Identifier

In this course, we will be using the Snap-on ZEEAC312C Refrigerant Identifier, which will identify and display the percentages of R-134a, R-12, R-22, hydrocarbons, and air. In the event that the refrigerant identified matches the profile of one of the listed EPA Significant New Alternatives Policy (SNAP) blends, the possible group will also be identified. This identifier will issue a pass if the selected type of refrigerant is at least 98% pure. It can also purge air from uncontaminated tanks and systems.

As with most identifiers, the Snap-on ZEEAC312C Refrigerant Identifier is very easy to use. The procedure is done with the engine off. The identifier is connected to the vehicle's A/C system low side to obtain a vapor sample. Sample pressure will be displayed on the instrument panel gauge, and should be at least 10 psi for proper identification. The panel digital readout will display setup instructions, commands, and test results. The user presses two key pads ("A" and "B") to input selections and to run tests. Results can be sent to a user-supplied printer. We will run through the basic setup and operations, and present some simulated tests here. Read the operation manual for further details before use.

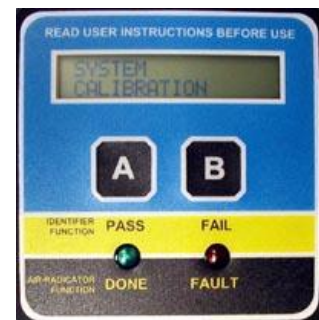

The Snap-on ZEEAC312C Refrigerant Identifier must only sample vapor, never liquid. To protect the machine, the sample filter is prominently displayed for visual inspection. The filter should be checked every time the identifier is used. Liquid or oil will appear on the filter as red spots or discoloration. Replace the filter if any red spots or discolorations are evident.



After the sample hose is connected from the vehicle low side service port to the identifier inlet port (finger tight), verify that the air purge vent cap next to the filter is installed to prevent excessive loss of refrigerant, and that the ports for the air intake, sample exhaust, and case vent are clear. When the identifier is plugged in to a power receptacle, it will begin a three-minute warm-up period. The panel will display various parameters and then you will see a reminder to check the filter.



During the warm-up period, the user has the option of entering the local elevation above sea level into the unit's memory. The instrument is sensitive to elevation differences of 500 feet (152 meters). After your local elevation has been entered into memory once, there is no need to enter it again unless the unit is moved to a new elevation. The elevation can be entered into memory by pressing and holding both the "A" and "B" keys simultaneously until the display reads:

USAGE ELEVATION  
400 FEET (122 meters)

The "A" and "B" keys are then used to raise or lower the elevation setting in increments of 100 feet (30 meters), "A" to increase and "B" to decrease, through a range of 0 to 9,000 feet (0 to 2,743 meters). The elevation you select will be set in memory after 20 seconds of not pressing either key, and the unit will then automatically return to the warm-up period.

After the warm-up period, the unit will self-calibrate. Ambient air is drawn in through the air intake port and presented to the sensing device for calibration, which takes approximately 20 seconds.

When the calibration has completed, the unit will display:

SELECT A SYSTEM  
A: R134a B: R12

After you select the type of system to be tested, the display will read:



READY: CON. HOSE  
PRESS A TO START

The green LED will begin flashing at this time. Now, you should connect the service end of the sample hose to the low side or vapor port of the refrigerant storage vessel or the vehicle A/C system to be sampled. When the hose is properly connected, press the “A” key to start the identification process. Remember, you need at least 10 psi on the unit’s sample pressure gauge. The display will indicate:



SAMPLING  
IN PROGRESS

After the analysis is complete, the results will be displayed and one of the LEDs will illuminate: green for a PASS and red for a FAIL. The weight concentrations of R-12, R-134a, R-22, hydrocarbons, air, and the SNAP blend group (if a match is detected) will also be displayed. In the event of a FAIL, an alarm will also sound.

If hydrocarbons are detected in excess of 2%, the red FAIL LED will light, the alarm will sound, and the display will show, “HYDROCARBON HIGH” along with the weight percentages.

**WARNING:** The hydrocarbon alarm alerts the user to the presence of potentially flammable refrigerant mixtures. It is your responsibility to ensure the removal of the potentially hazardous mixture from the instrument and any other attached equipment.

The display will prompt you to press “A” to print the results, or “B” to continue or exit.

#### Operational Tips

- It is suggested to retest a refrigerant source for verification whenever a FAIL result is issued
- For the best detection of air, allow the unit to warm up for an additional five minutes after the first warm-up period before pressing the “A” key to start the sampling process. This allows more stabilization of the sensing device. During the additional warm-up, the instrument will “time out” and display, “RECALL REQUIRED”. Disconnect the sample hose from the refrigerant source and press the “A” key to recalibrate. After the unit recalibrates, it will not be necessary to warm it up again between sample runs unless it is powered down
- During warm-up, results from the last sample run may be printed, even if the unit has been previously powered down
- The unit will not allow purging procedures on contaminated mixtures

### ***Finding Refrigerant Leaks***

Refrigerant leaks are one of the most common problems encountered with A/C systems. If a system has a very low refrigerant charge or is empty, it must have a leak. The only exceptions to this would be occasions when a vehicle is brought in empty after collision damage and repair to the condenser, or after a damaged hose has been replaced, or the like. Large leaks are sometimes obvious. A large leak will usually be indicated by an oil stain near the leak. The oil stain may be marked by the presence of dirt sticking to the oil.

### UV Dyes

Before you proceed further, you may want to use a UV (ultraviolet) leak detector to look for leaks. These leak detectors use an ultraviolet light to illuminate a dye that mixes with the oil in the system. Many systems now contain a UV dye installed at the factory, and others may have had a dye added already. The dye glows green or yellow under the UV light. These leak detectors are especially useful for small, high-pressure or flex leaks that may show up only under certain operating conditions. We will discuss UV leak detectors in more detail later.

### Common Leak Areas

You should check these places first, if you suspect a leak:

- **Service ports:** Very important! To begin with, the service port caps must be securely in place. While the Schrader valves are the primary seals for the ports, the caps serve as secondary seals in the case of leakage. The caps also keep the valves clean and protected. Up to a pound of refrigerant a year can seep from uncapped ports, especially since Schrader valves can stick or not seat properly. Sometimes, simply operating the valve stem manually a couple of times will permit the valve to seat properly.
- **Pressure switches:** These switches are susceptible to leaks. Check the fitting and unplug the switch to check around the electrical connections.
- **Connections:** Check around connections between components, lines, and hoses. Connections can become loose, or O-rings can fail. Torque threaded connections carefully to prevent leaks or damage to aluminum parts.

Evaporators will sometimes develop leaks due to corrosion. Look for evidence of oil at the bottom of the evaporator housing and at the drain hole or tube. Small evaporator leaks will require the use of a leak detector.

If a system comes in empty and no leak is obvious, you'll have to add about a pound of refrigerant to check for a leak. It takes about 15% of the total charge in order to bring the system up to a pressure of about 50 psi to perform leak testing. At this point, large leaks may be indicated by a hissing sound or bubbling of oil from the leak. Recover the refrigerant before opening the system.

**WARNING:** R-134a and air in pressurized mixtures can become combustible. Do not use compressed air to pressure test a system or equipment. Compressed shop air also contains moisture, which should not be introduced into any system. Shop air pressure can damage evaporators, as well.

To find small leaks, you will need to use an electronic or ultraviolet leak detector. Identify the refrigerant in the system before using an electronic leak detector, since some leak detectors could provide a source of ignition to flammable hydrocarbons.



### Electronic Leak Detection Using the Snap-on® ACT755

In this course, we'll be using the Snap-on ACT755 Electronic Leak Detector with UV Blue Light. Other units are similar in operation. This detector incorporates both electronic and UV light detection functions into a single unit. We'll start with the electronic detector function.

The ACT755 Leak Detector has six levels of sensitivity. When set at its highest sensitivity, it can detect a leak of 1/10 ounce per year. Here, you see the control panel keypad and the wand tip.

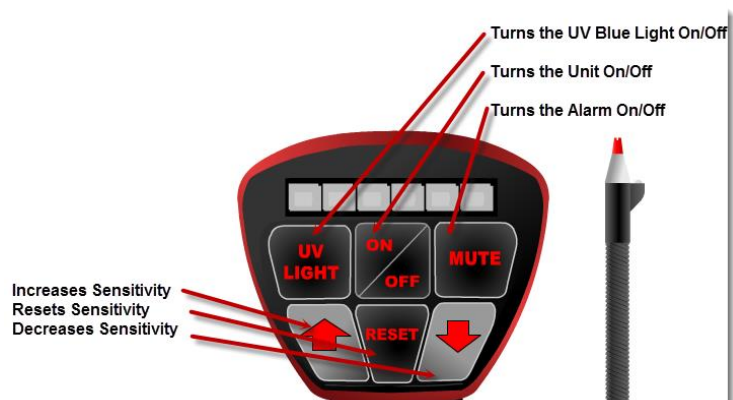

The sensitivity setting is checked and adjusted by pressing either of the arrow keys. The lowest setting will show one red LED illuminated on the right of the display. Pressing the UP arrow will increase the sensitivity. The level of the setting will be indicated by the number of illuminated LEDs, up to Level 6. When the unit is turned on, it defaults to Level 5. This is the recommended level to begin inspection.

The unit will begin beeping when turned on, and the beeping will slow down at lower detection levels. Two seconds after pressing an arrow key, the unit goes into normal detection mode.

When the ACT755 detects refrigerant at the sensor tip, it responds according to the concentration of refrigerant present, through up to 15 gradient levels. Detection begins at the lowest level with one red LED illuminated, then an increasing number of red LEDs will light as the level increases. As the level continues to rise, the LEDs go through yellow and finally green at the highest levels of concentration. The beep alarm increases in speed, accordingly. The detection level displayed is dependent on the sensitivity setting. In other words, the same size leak will display higher detection levels at higher sensitivity settings.

The tool's RESET key can be helpful in pinpointing the source of a leak. After a leak has been detected at a certain level, pressing this key will automatically adjust the sensitivity of the unit to ignore concentrations at that level, and only detect leaks of a higher level.

### Tips for Using the Electronic Leak Detector

To check the system for leaks, first ensure that there's sufficient pressure – at least 50 psi is required at an ambient temperature of 60° F (60° C) with the system off. About 7% to 15% percent of the system's normal charge should be enough; the system does not need to be full to find a leak.

Without any equipment attached to the service ports, trace the system with the sensor tip about ¼ inches (5mm) from the surface, at a rate of about one to two inches (25-50mm) per second. Pay particular attention to fittings and seals, service ports, and hose joints. Check carefully around any abrasions or possible rub-through areas. While refrigerant is heavier than air and may tend to drop or pool in low areas, a leak can occur anywhere, so check all the way around the lines. When you detect a leak, confirm the exact location by gently blowing shop air around the suspected leak area. Move the sensor into fresh air and reset it, then check the leak again.

Check the evaporator drain hole. You may be able to access the ducts by gently probing into the vents. To get better access to the evaporator, you may have to consult the service manual. Access is provided on some vehicles by removing the blower resistor; other evaporators may be reached by way of removing the glove box. To find a small evaporator leak, you may need to run the system for a few minutes and then let it sit to allow the leaking refrigerant to collect in the housing. You can confirm the leak by turning on the blower to clear out the evaporator and ducts, and then rechecking.

When working in contaminated or high humidity areas, you may sometimes get erratic or false detections, especially at high sensitivity settings. If this occurs, allow the unit to adjust to the environment. You can press the reset button to adjust the sensitivity for the conditions. Get to know your electronic leak detector by experimenting with it using your shop's recovery/recycling equipment. Check all of the connections. Check all the valves and fittings on all refrigerant tanks. This is a good practice, and should be done periodically anyway. Adjust the sensitivity level and try out the reset feature. (Don't release refrigerant into the air.)

### UV Leak Detection

Another way to find leaks is by using ultraviolet light to illuminate dye that has been injected into the system. This may be the best way to find some small leaks that occur only during special circumstances, such a driving vibrations, road shock, or flexing of components and lines.

On systems that have not had dye injected at the factory or in previous service, you may be able to inject an application of dye and find a leak with a UV light after running the system for a few minutes. For slow leaks, you may have to inject the dye and have the customer return in a few days or even weeks. Before injecting an application of dye, check your service information to see if the system included dye from the factory, and if not, try to determine if a dye charge has been added during service. Too much dye in a system can affect oil distribution and cause compressor damage. A standard dye application is ¼ fluid ounces. The Chrysler Group discontinued factory dye installation for 2003. Dye is normally filtered out of the system during recovery and recycling, so if you wish to add dye to a system as a future diagnostic aid, do it after you have completed evacuating/recharging the system.

### **Dye Cleaner and Dye**





Most newer dyes are "universal" and will work in both R-12 and R-134a systems, but older dyes for either type of system **are not compatible** for the other type. Make sure you use the right type of dye for the system.

When using a UV light, such as the one at the wand tip of the ACT755, always wear the provided UV protective glasses to shield your eyes from the ultraviolet light. The glasses also help enhance the luminescence of the dye. With the engine off, sweep the system in a similar manner as you would if you were using the electronic function. You don't have to hold the tip as close to the surface, but carefully check all of the same trouble areas we discussed.

After you find the leak and make the necessary repairs, thoroughly clean any dye from components and lines, to prevent a false indication of a leak later. Recheck the system for leaks, and then evacuate and recharge the system. Add an application of dye, if desired.

**UV Protective Glasses**



### ***Refrigerant Recovery and Recycling (Charging), and Evacuating the System***

Before you can open an A/C system to make repairs, you must recover the refrigerant, whether it is an R-12 or an R-134a system. This is not only environmentally responsible, it's federal law. Read the operator's manual supplied with your A/C equipment and keep it handy. It contains information to help you perform A/C service properly, as well as important information for maintenance of the machine.

**Read and follow all safety information.**

In general, any type of service to the refrigeration system will require recovery of the refrigerant from the system. Even if a system is functioning, and only a "little low" on refrigerant, the refrigerant should be recovered and the system recharged, rather than just adding some refrigerant. You may have to explain this to customers who request that the system just be "topped off." The reason for this is that you can't accurately determine how much refrigerant is in the system; therefore, you can't tell how much refrigerant to add to bring the system to a full charge. Proper charge level is critical on modern systems. Back in the days of large capacity, R-12 systems, the charge level was not as crucial as it is in today's smaller, 134a systems. The trend continues to be towards smaller systems, with some new ones containing only a pound of refrigerant or less. The common tolerance for system charge levels is in a range from the specification for a full charge down to a minimum of two ounces below this spec. Overcharging can cause system damage and poor performance. The right charge level is vital in providing optimum system performance throughout the various possible operating conditions. Refrigerant recovery and careful recharging will ensure that the system contains the proper charge of pure, dry refrigerant and lubricant, for long, trouble-free operation.

### Refrigerant Containers

Use only a recovery tank of the type supplied with your recovery/recycling machine. Tanks that are suitable for recovery will be marked "DOT 4BA" or "DOT 4BW," indicating that they are approved by the Department of Transportation. Never attempt to collect, salvage, or restore refrigerant to a disposable container. New recovery tanks delivered with the unit are frequently shipped with an air charge. The tank must be evacuated and filled according to the equipment operator's manual. Empty disposable tanks must be evacuated to recover all refrigerant, and disposed of properly. Never fill a recovery tank to more than 60% of its gross weight rating, unless your equipment operator's manual expressly states a higher capacity is OK. A 50 lb container can be safely filled to 30 lb. Overfilled tanks can pose an explosion hazard as temperatures and pressures rise. Excessive air in the recovery tank will elevate the pressure. Follow the instructions that came with your recovery/recycling equipment for checking and/or purging air from the tank.

### Recovery

Recovery is performed with an A/C recovery/recycling machine. There are many types available to perform different types and levels of service. In the section called "What's in the System," we noted that many shops have an additional, older machine dedicated to recovering only refrigerant that has been identified as contaminated. Most of the newer machines will recover, recycle, evacuate, and recharge, either automatically or semi-automatically. Many have air purge functions that will purge non-condensable gases with the press of a button. In addition, many designs filter and dry the recovered refrigerant before it enters the recovery tank. Refrigerant in the tank is thus immediately recycled and ready to be re-used.

To recover the refrigerant from an A/C system, the recovery unit's service hoses are connected to the vehicle's service ports. EPA regulations require that the service hoses have shutoff valves no more than 12 inches from the ends, to minimize refrigerant loss. Newer vehicles have a different sized fitting for the low and high side service ports, but in any case, make sure you have properly identified the high and low sides before you attempt to attach the hoses. **Don't inadvertently attach the hoses to vehicle fuel system ports!** This can happen on some light trucks, Mercedes, and Fiat models, as they use the same type of fittings as the A/C service fittings for R-12. Fuel in an A/C recovery unit may cause an explosion or fire.

Refer to the operating instruction manual for your unit. The vehicle should be at normal operating temperature, engine and A/C system off. The recovery operation generally consists of opening both of the hose valves, both of the recovery tank valves, and both of the unit's control valves, and then starting the recovery function. The machine will then recover the refrigerant and pull a vacuum on the system. The vacuum should be pulled to about 15 inHg, and should hold steady for at least five minutes. If vacuum does not hold steady, check all service connections. If you suspect a vehicle leak, you can add a partial charge of refrigerant at this time, and then check for leaks.

If the vehicle A/C components show icing during recovery, you can gently warm them to speed up and ensure recovery of all refrigerant. On some orifice tube systems, oil in the accumulator can trap refrigerant in the system. As the system warms up, the trapped refrigerant may be released suddenly. Any such "outgassing" must occur while the system is under recovery, and not after it has been opened. Outgassing of refrigerant can be accompanied by a burst of oil through the system. Keep this in mind when you open the system, and take proper safety precautions.

After recovery is complete, close the hose valves. Then measure and record the amount of oil recovered from the system, and drain the waste oil from the bottle into a vessel for proper disposal according to applicable local, state and federal regulations. You will need to replace the oil with the same amount of fresh oil when you recharge the system, along with the proper amount of oil contained in each component you replaced. The vehicle service manual will list the oil charge for each component, as well as total oil charge for the system.

You are now ready to open the system and make repairs. Avoid leaving the system open to the air while performing repairs. Keep in mind that the accumulator or receiver/dryer should be replaced under these conditions:

- With major component repairs
- If your diagnosis indicated the presence of moisture in the system
- If the system has been left open to the air

The desiccant bag in accumulators or receiver/dryers can suspend only a limited amount of moisture – and moisture is the enemy of A/C systems! Don't break the inlet and outlet seals of any new component until you are ready to install it to the system's line fittings.

#### Evacuating the System

After the repairs have been made, you should perform an evacuation of the system. Evacuation is necessary after a system has been opened to replace parts, or if the system came in with no pressure. Evacuating the system will remove air and some moisture, ensuring a long-lasting repair. Recall from our discussion of changes of state how a lower pressure reduces boiling temperature. Under a vacuum of 29 inHg, water boils at 70° F.

The evacuation procedure is similar to recovery, and is performed after recovery (if the system is not going to be opened) or before recharging. Be sure all refrigerant has been recovered first. Refer to the operating instruction manual for evacuation using your unit. In general, both service hose valves and both of the unit's control valves are opened, and the vacuum function is selected. The system will need to be evacuated for about 30 minutes, down to a deep vacuum of near 30 inHg. The vacuum is then held for another five minutes, to allow time for the moisture to be fully vaporized and removed. If vacuum does not hold steady, check all service connections. If you suspect a vehicle leak, you can install a partial charge of refrigerant, and then check for leaks.

Vacuum pumps for A/C systems require maintenance to keep them operating well enough to evacuate a system properly. Check the oil level and color each time before you use the pump. The oil should be clear when viewed through the sight glass. Change the oil at 6-month intervals or when the sight glass is cloudy, whichever comes first. Keep in mind that a vacuum pump can't pull as much vacuum at elevations high above sea level. After the system has been successfully evacuated and held for five minutes, you are ready to recharge the system

### Charging the System

It is possible to recharge a system manually using charging cylinders and an accurate weight scale and thermometer. When charging from a recovery tank, ensure that no air is present and the refrigerant is pure.

Recharging the A/C system is much simpler, faster, and more accurate with a recovery/recycling machine. Follow the instructions for your recovery/recycle equipment for recharging the system. In some cases, you will enter into the machine the amount of refrigerant you want to install; in others, you will monitor the charge weight on a display. Consult the under hood sticker or vehicle service manual for the proper amount for the system.



The machine's hoses are typically recovered after each use. If the hoses have been recovered, **include two additional ounces over this amount per service hose, to account for their capacity.** Then, with the system off, and all valves set as directed, start the recharge function.

Regardless of how you recharge the system, there are a few rules to follow:

- Never open the high-side control valve with the system running! High-side pressures can blow a tank apart!
- Charging a running system with liquid refrigerant through the low side can destroy the compressor! The compressor cannot compress a liquid. Charging liquid through the low side with the system off can wash the oil from the compressor and cause damage.
- Sometimes recharging will slow to an unacceptable pace before completion. When this happens, close the control valves and start the engine, then turn on the A/C system. Finish charging with vapor through the low side with the system running.

Recover the refrigerant from the service hoses after you are finished.

### **Using the Snap-on® ECO Xtreme™ Unit**

In this course, we will be demonstrating recovery, evacuation, and recharging operations using the Snap-on ECO Xtreme™ (EEAC318A) unit. This unit is a single-pass design, meaning that recovered refrigerant is dried and filtered before entering the recovery tank, so recycling is automatic. Functions are performed semi-automatically from the unit's control panel. The control panel includes a Liquid Crystal Display (LCD) for displaying functions and user-prompts, and four buttons for navigation and selection.

The 50-pound capacity recovery tank is temperature-monitored to maintain accurate purging of air under all conditions. The tank is set on an electronic weight scale. The unit also features a gauge set, manual control valves with hoses, fittings and adapters, and an oil drain bottle. Be sure to read and understand the operator's manual and all safety information before setting up and using the unit.

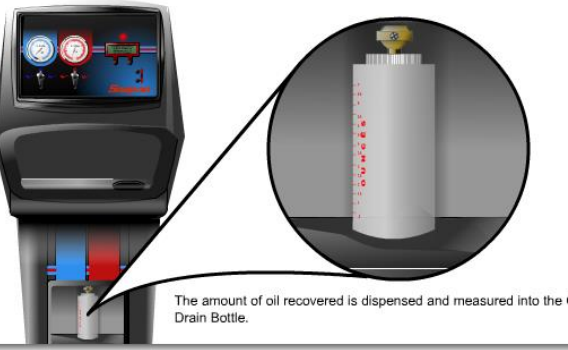
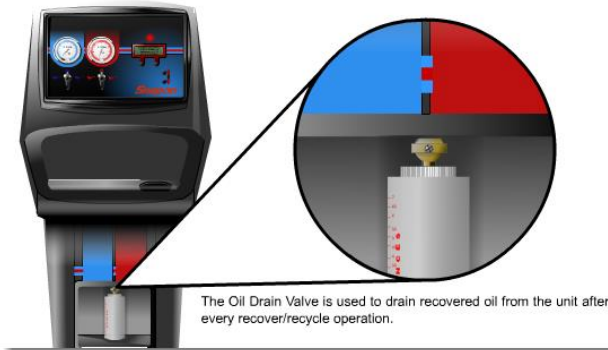
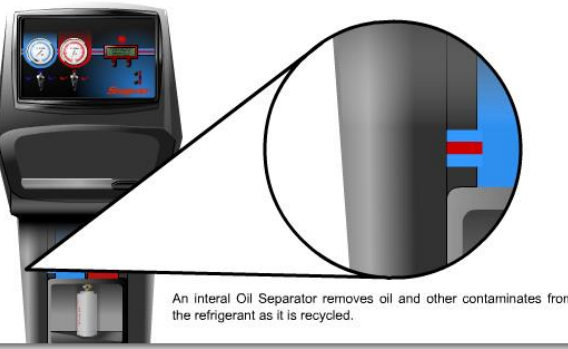
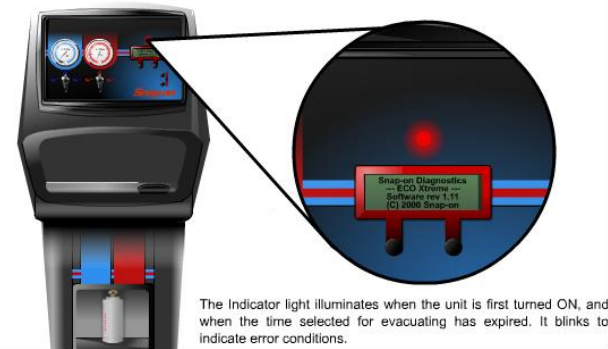
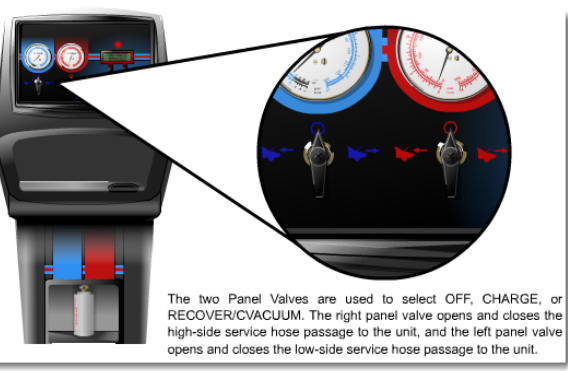
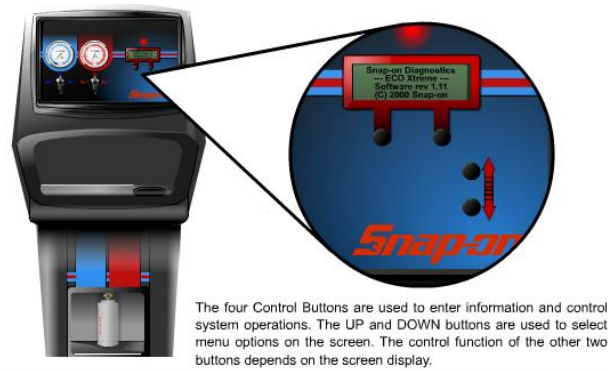
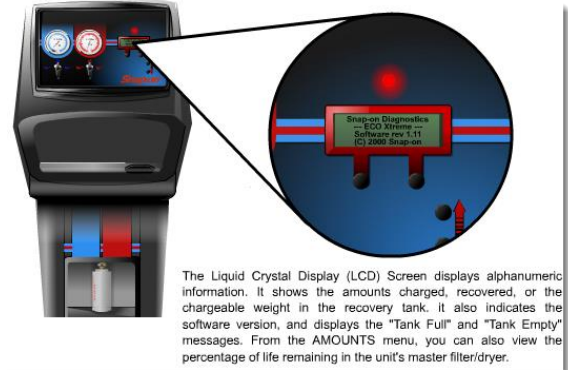
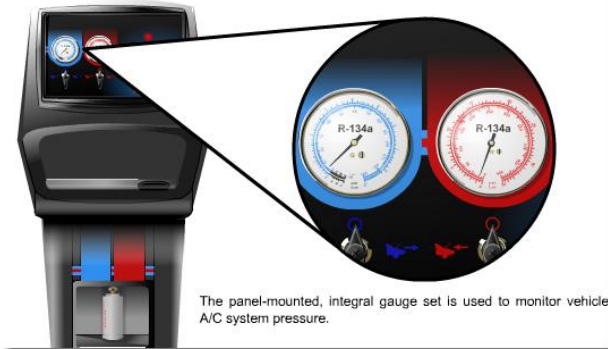

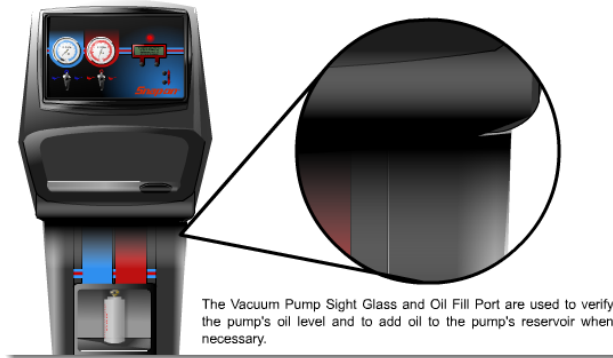

The recovery tank is shipped with a dry air charge. The charge must be vented and the tank evacuated before use. An unprepared tank can cause compressor burnout. To prepare the tank, an evacuation procedure is performed on the tank down to a minimum of 25 inHg, then a recovery procedure is carried out on a virgin refrigerant tank, just as you would recover refrigerant from a vehicle's system into the recovery tank. Refer to the operator's manual for the procedures. The recovery tank must have a minimum of six pounds of refrigerant to perform a charge operation.

Be sure to lubricate rubber gaskets and seals at hose connections with fresh refrigerant oil before connecting. Close the recovery tank valves to prevent possible refrigerant loss when the unit is not in use.

Note that the startup screen displays the software version number and then the Main Menu screen is displayed. The arrow indicator defaults to the "Recover" selection. The red LED goes out when the unit is ready for use. Also, note the layout of the buttons, gauges, and panel valves. Each panel valve has three positions indicated by symbols as follows:



#### **OFF Low-Side**

Left panel valve pointed toward this symbol (up) indicates the blue, low-side service hose passage is closed to unit operations while still registering vehicle A/C system pressure on the gauge.



#### **CHARGE Low-Side**

Left panel valve pointed toward this symbol (left) indicates refrigerant being charged through the low-side service hose. The arrow points toward the car's under hood area.

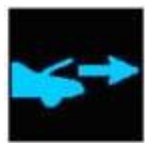

#### **RECOVER / VACUUM Low-Side**

Left panel valve pointed toward this symbol (right) indicates system being recovered or evacuated through the low-side service hose. The arrow points away from the car's under hood area.

**OFF High-Side**

Right panel valve pointed toward this symbol (up) indicates red, high-side service hose passage is closed to unit operations while still registering vehicle A/C system pressure on the gauge.

**CHARGE High-Side**

Right panel valve pointed toward this symbol (left) indicates refrigerant being charged through the high-side service hose. The arrow points toward the car's under hood area.

**RECOVER/VACUUM High-Side**

Right panel valve pointed toward this symbol (right) indicates system being recovered or evacuated through the high-side service hose. The arrow points away from the car's under hood area.

The Setup menu allows you to adjust the display's contrast, select the desired language and units of weight, and reset the automatic reminder for the master filter/dryer after replacement.

## Chapter 2: Testing and Service of Heating and Cooling System Components

The modern cooling system has evolved a great deal over time. However, its basic function is still the same. Today's vehicles still depend on liquid to transfer heat from the engine block to the radiator to be cooled before returning to the engine block. For modern engines to operate efficiently they must maintain a constant temperature over a wide range of operating conditions.

**WARNING:** When checking or testing the cooling system always make sure that the engine is cool. Removing a radiator cap on a hot engine can cause serious burns.

### Coolant

Coolant should be maintained according to manufacture recommendations. Modern vehicle use different types of coolant. The days of all coolant being relatively the same has passed. Mixing incorrect coolant can lead to coolant system and early engine failure. The most common type of coolant is a 50/50 mixture of water and ethylene glycol. A less toxic coolant is propylene glycol. Some manufacturers also use extended-life coolants.

### Hoses

When servicing the cooling system, inspect hoses to make sure that they are not swollen, soft, cracked or hardened. Any that are should be replaced. A busted radiator hose can cause major engine damage if the vehicle is allowed to run hot.

### ***Water Pump***

A water pump is used to circulate coolant throughout the cooling system using hoses and pipes to transfer coolant from the engine to the radiator. When inspecting the cooling system check the water pump for signs of coolant leakage.

Always check the weep hole for signs of coolant leakage. Check the water pump shaft for looseness - this can be an early indication of water pump failure. It is a good idea to repair any problems leading to coolant leakage before they become major problems.

### ***Thermostat***

The thermostat is used to help the engine maintain a constant operating temperature. Modern engines use either a fan clutch or an electric fan to assist in removing heat from the radiator when the engine temperature rises beyond a programmed level.

Checking the engine operating temperature is an important part of any cooling system service. A thermostat can fail in both the open or closed positions, which means that a defective thermostat can cause an engine to run hotter or colder than normal. If a thermostat is stuck closed, it can cause the engine to run hot enough to cause engine damage. A thermostat that is stuck open will cause an engine to run much colder than normal, causing the engine to run less efficiently.

It is important to make sure the thermostat is installed in the correct direction with the sensing pellet toward the engine block. Failure to do so will cause the engine to overheat. Always replace a defective thermostat with the correct replacement. Failure to do so will result in a vehicle not running as efficiently as normal.

### ***Radiator***

A radiator is used to remove heat from coolant before the coolant is returned to the engine. When servicing the cooling system always check the radiator for blockage and leakage. A common cause of blockage in radiator is debris that gets stuck between the radiator and the AC condenser. The radiator cap should be inspected as part of any cooling system service.

Also note that using incorrect or worn coolant can cause the radiator to corrode and fail prematurely.

### ***Testing and Inspecting the Cooling System***

Cooling systems can be easily checked for leaks using a cooling system pressure tester. When testing the system, remove the radiator cap and apply pressure to the recommended level stamped on the cap.

Cooling systems can leak in several different places. If a sweet smell of coolant is noticed when the defogger is turned on, check for a heater core leaking. Coolant escaping from a vehicle with no signs of external leakage can mean internal leakage. Internal leakage can be due to blown head gaskets, a cracked block, or a cracked cylinder head.



**Additional Pages**

System Diagnostic Worksheet	1
Air Conditioning Customer Complaint Worksheet	2
Test Results for CCOT Refrigeration System	3
Test Results for VDOT Refrigeration System	4
Diagnostic Chart for a Typical Clutch Cycling Orifice Tube (CCOT) HVAC System	5
Diagnostic Chart for a Typical Clutch Cycling Expansion Valve (CCTXV) HVAC System	6

# System Diagnostic Worksheet

## Complaint:

- No A/C      Insufficient A/C      Odors/Leaks      Driveability problem with A/C on  
 Noise      Other \_\_\_\_\_
1. When does the complaint occur?  
 Always      Other \_\_\_\_\_
2. Temperature/conditions when complaint occurs:  
 Always      70° - 90°      90° +      High temperature / High humidity
3. Vehicle condition / maneuver when complaint occurs:  
 Always      Engine idling      Cruising      Under load      Other \_\_\_\_\_

## Function Tests Status

1. Blower Fan Operation:  
 OK      No High Blower      Missing speeds      Other \_\_\_\_\_
2. Air Distribution:  
 OK      No Defrost      No Panel      No Floor      No Recirculation  
 Other \_\_\_\_\_
3. Temperature Controls:  
 OK      No temp. change      Control lever problem      Other \_\_\_\_\_
4. A/C Function:  
 OK      No clutch operation      Clutch operates; no temperature change  
 Clutch operates; some temperature change      Other \_\_\_\_\_

## Supporting Systems Tests Status

1. Electric Cooling Fan:  
 OK (Fan comes on with A/C)      Fan operates continuously with no A/C clutch operation  
 Fail (Fan doesn't come on with A/C)      Other \_\_\_\_\_
2. Cooling System:  
 OK      Signs of overheating      Other \_\_\_\_\_
3. Heater Control Valve (if applicable):  
 OK      Stuck Open      Not being controlled      Other \_\_\_\_\_

## System Repair Needs

1. Electrical diagnosis of:      Fan Blower Motor      A/C Clutch      Electric Cooling Fan  
 Other \_\_\_\_\_
2. Diagnose ventilation system:      Air Distribution      Temperature Controls  
 Other \_\_\_\_\_
3. A/C refrigerant system:      Performance Test      Leak Test  
 Other \_\_\_\_\_

# Air Conditioning Customer Complaint Worksheet

## (Check all that apply)

**Customer complaints:**

A/C inoperative (No cooling)	
A/C insufficient (Some cooling)	
A/C odor	
A/C leaks (Floor/Carpet inside the vehicle gets wet)	
Not enough or no air comes out of the vents	
Air comes out of the wrong vents	
Driveability problem (Turning A/C on or off makes the vehicle run funny)	
Service Engine Soon light on? (Not all vehicles have this...)	
Other service lights or messages? (Not all vehicles have this...)	
The problem started all at once (Fine yesterday, broken today)	
The problem started slowly over time / mileage (Performance degraded)	
Have the A/C, Heater or Engine Cooling systems been worked on lately?	

Detail any of the conditions above as necessary: \_\_\_\_\_

\_\_\_\_\_

\_\_\_\_\_

\_\_\_\_\_

**When does the complaint or problem occur?**

Any or all the time the vehicle is running, with A/C turned on or off	
Any or all the time the vehicle is running, with A/C turned on	
Only when the engine is cold	
Only when the engine is warmed up	
While starting the car or shutting it off	

Detail any of the conditions above as necessary: \_\_\_\_\_

\_\_\_\_\_

\_\_\_\_\_

\_\_\_\_\_

**Under what climate and operating conditions does the problem occur?**

All the time (Not dependent upon outside temperature)	
Only when the outside temperature is 70°-90°F (21°C-32°C)	
Only when the outside temperature is over 90°F (32°C)	
Only in high humidity conditions (60% or higher estimated)	
When the engine is idling (At a stop light or stopped in traffic)	
When driving in town (Low speed operation)	
When driving at highway speeds (50 MPH / 80 KPH and faster)	
Under acceleration or load (Going over hills, mountains, up on-ramps)	

Detail any of the conditions above as necessary: \_\_\_\_\_

\_\_\_\_\_

\_\_\_\_\_

\_\_\_\_\_

RELATIVE HUMIDITY	AMBIENT AIR TEMP		MAX LOW SIDE PRESSURE		MAX HIGH SIDE PRESSURE		MAX RIGHT CTR AIR OUTLET TEMP	
	%	°F	°C	psi	kPa	psi	kPa	°F
20	70	21	23	159	190	1313	42	6
	80	27	30	207	250	1728	50	10
	90	32	35	242	300	2074	54	12
	100	38	37	225	330	2281	57	14
30	70	21	23	159	200	1383	42	6
	80	27	30	207	280	1936	51	11
	90	32	35	242	310	2143	55	13
	100	38	37	255	335	2310	58	15
40	70	21	23	159	200	1379	43	6
	80	27	31	214	285	1965	52	11
	90	32	36	248	320	2206	56	14
	100	38	43	296	370	2551	64	18
50	70	21	23	159	200	1379	43	6
	80	27	33	228	300	2068	54	13
	90	32	39	269	340	2344	60	16
	100	38	47	324	385	2654	69	21
60	70	21	23	159	200	1379	43	6
	80	27	36	248	315	2171	56	14
	90	32	43	296	365	2516	64	18
	100	38	55	379	375	2585	78	26
70	70	21	26	179	240	1655	46	8
	80	27	38	262	325	2240	58	15
	90	32	47	324	380	2620	67	20
80	70	21	30	207	260	1792	49	10
	80	27	40	276	340	2344	60	16
	90	32	49	338	380	2620	72	22
90	70	21	32	221	275	1896	52	11
	80	27	41	283	345	2378	62	17

NOTE: PERFORMANCE DATA OBTAINED AT ENGINE SPEED OF 2000 RPM.

### Performance Test Results for a Typical CCOT Refrigeration System

RELATIVE HUMIDITY	AMBIENT AIR TEMP		MAX LOW SIDE PRESSURE	MAX HIGH SIDE PRESSURE	MAX RIGHT CTR AIR OUTLET TEMP	
	%	°F	°C	psi	psi	°F
20	70	21	29	150	40	4
	80	27	29	190	44	7
	90	32	30	245	48	9
	100	38	31	305	57	14
30	70	21	29	150	42	6
	80	27	30	205	47	8
	90	32	31	265	51	11
	100	38	32	325	61	16
40	70	21	29	165	45	7
	80	27	30	215	49	9
	90	32	32	380	55	13
	100	38	39	345	65	18
50	70	21	30	180	47	8
	80	27	32	235	53	12
	90	32	34	295	59	15
	100	38	40	350	69	21
60	70	21	30	180	48	9
	80	27	33	240	56	13
	90	32	36	300	63	17
	100	38	43	360	73	23
70	70	21	30	185	50	10
	80	27	34	245	58	14
	90	32	38	305	65	18
80	70	21	30	190	50	10
	80	27	34	250	59	15
	90	32	39	310	67	19
90	70	21	30	200	50	10
	80	27	36	265	62	17
	90	32	42	330	71	22
NOTE: PERFORMANCE DATA OBTAINED AT ENGINE SPEED OF 1200 RPM.						

**Performance Test Results for a Typical VDOT Refrigeration System**

## Diagnostic Chart for a Typical Clutch Cycling Orifice Tube (CCOT) HVAC System

System Operating Normally – Fully Charged				
Low Side	High Side	Evaporator Outlet	Duct Temperature	
23 - 48 psi 159 – 331 kPa	150 - 375 psi 1034 – 2585 kPa	Cold	40° - 55° F 4.5 ° - 13° C	
Diagnostic Chart				
Low Side	High Side	Symptoms	Diagnosis	Solutions
Low to Normal 10 - 46 psi 68 - 317 kPa	Low to Normal 120 -170 psi 827 - 1172 kPa	Pool cooling. Warm evaporator Outlet line. Compressor clutch cycling rapidly.	Low refrigerant charge.	Check and repair any leaks in the system. Recharge system as needed.
Low to Normal -10 to 10 psi -68 to 689 kPa	Low to Normal 90 -170 psi 620 - 1172 kPa	Poor cooling. Warm evaporator outlet line. Compressor clutch cycling rapidly.	Restriction or bad orifice tube. Gauge reading may be higher if the restriction is directly pas the service fitting.	Check for a clogged orifice tube. Evacuate and recharge the system.
Normal to Low 5 - 48 psi 34 – 331 kPa	Normal 185 - 375 psi 1275 – 2585 kPa	No air or warm air from the ducts. Evaporator lines cold or iced.	Evaporator freeze-up. Bad thermostatic switch or cycling switch. Evaporator freeze-up at low blower speeds or during long drives.	Replace cycling switch or thermostatic switch. Make sure you reinstall capillary tube in the original location.
High 60 - 100 psi 414 – 689 kPa	Low 70 - 120 psi 483 – 827 kPa	No cooling. Warm evaporator outlet pipe.	Bad compressor.	Repair or replace compressor. Replace accumulator. Evacuate and recharge the system.
High 40 - 60 psi 276 – 414 kPa	High 200 - 400+psi 1379 – 2758+ kPa	Fair to poor cooling. Evaporator outlet cool to warm. Compressor doesn't cycle.	System overcharged.	Recover excess R-12 or R- 134a until the A/C system operation return to normal.
Normal to High 15 to 55 psi 100 – 379 kPa	High 200 to 300+psi 1379 – 2068 kPa	Fair to poor cooling. Evaporator outlet cool to warm.	Engine overheating. Restricted airflow past condenser.	Check cooling system operation. Check cooing fan operation. Clear radiator or condenser restriction.

## Diagnostic Chart for a Typical Clutch Cycling Expansion Valve (CCTXV) HVAC System

System Operating Normally – Fully Charged				
<b>Low Side</b>	<b>High Side</b>	<b>Evaporator Outlet</b>	<b>Duct Temperature</b>	
15 – 30 psi 100-207 kPa Pressures will be higher at higher blower speeds.	150 – 285 psi 1034 -1965 kPa Low condenser airflow increases high side pressures.	Cold – Lines sweating heavily, no frost.	40° - 50° F 4.5° - 10° C	
Diagnostic Chart				
Low Side	High Side	Symptoms	Diagnosis	Solutions
Low to Normal 15 - 30 psi 100 - 207 kPa	Low to Normal 110 -150 psi 758 - 1034 kPa	Poor or no cooling. Compressor cycles rapidly. Warm evaporator outlet line.	Low or improper refrigeration charge.	Check and repair any leaks in the system. Recharge system as needed.
Low to Normal -20 to10 psi -137 to 68 kPa	Low to Normal 115 - 160 psi 792 - 1103 kPa	No cooling. Warm evaporator outlet line.	Moisture freezing at TXV. Bad expansion valve. Gauge reading may be higher if the restriction is directly past the service fitting.	Check the expansion valve and screen. Look for icing on the high-side lines. Clear the restriction or replace necessary components. Evacuate and recharge the system.
Normal to Low Switch 0 - 25 psi Switch 0 - 172 kPa	Normal 150 - 285 psi 1034 - 1965 kPa	Unit works fine for a while, then begins to blow warm air. Evaporator pipes frozen. Compressor doesn't cycle.	Evaporator freeze-up. Bad thermostatic switch of cycling switch.	Replace cycling switch or thermostatic switch.
High or Equal to High Side Gauge 70 - 90 psi 483 - 620 kPa	Low or Equal to Low Side Gauge 90 - 110 psi 620 - 758 kPa	No cooling. Warm evaporator outlet pipe. Compressor won't cycle.	Expansion valve stuck open. Bad compressor.	Repair or replace compressor. Replace expansion valve. Evacuate and recharge the system.
Normal to High 30 - 60 psi 207 - 414 kPa	High 200 - 300 psi 1379 - 2068 kPa	Fair to poor cooling. Evaporator outlet cool to warm.	System overcharged.	Recover excess R-12 or R-134a until the A/C system operation returns to normal.
Normal to High 30 - 60 psi 207 - 414 kPa	High 200 - 300+ psi 1379 - 2068+ kPa	Fair to poor cooling. Evaporator outlet cool to warm.	Engine overheating. Restricted airflow past condenser.	Check cooling system operation. Check cooling fan operation. Clear radiator or condenser restriction.