

MLR: Brakes



TABLE OF CONTENTS

Unit 1: Brakes Overview.....	5
Chapter 1: Brake System Fundamentals.....	5
Friction	5
Tire Footprint.....	6
Heat	7
Weight and Speed	7
Service Brakes & Parking Brakes.....	8
Base Brake Components.....	8
Brake Subsystems	9
Chapter 2: Brake Diagnosis Procedures	10
Work Orders	10
Brake Diagnosis	11
Fluid Levels and Leaks	12
Test Drive	15
Removing Brake Dust.....	17
Vehicle Lifting	18
Unit 2: Hydraulic System	18
Chapter 1: Introduction to the Hydraulic System.....	18
Hydraulic Principles	18
Master Cylinder	19
Split Hydraulic Systems.....	21
Balance Control Systems	22
Chapter 2: Servicing the Hydraulic System.....	23
Switches and Valves.....	23
Warning Light	23
Master Cylinder	24
Brake Pedal	26
Brake Fluid	28
Brake Bleeding.....	30
Lines and Hoses	37

Unit 3 Drum Brakes40

Chapter 1: Introduction to Drum Brakes 40

- Introduction..... 40
- Brake Drum..... 41
- Brake Shoes 42
- Wheel Cylinder 42
- Backing Plate 43
- Duo-Servo Brake Operation..... 43
- Self-Adjusters..... 44
- Leading-Trailing 45

Chapter 2: Servicing Drum Brakes..... 46

- Disassembly..... 46
- Inspection and Diagnosis..... 49
- Wheel Cylinder 52
- Reassembly..... 53
- Machine Drums 56
- Service Tips..... 60
- Wheel Assembly..... 60

Unit 4 Disc Brakes61

Chapter 1: Introduction and Servicing Calipers..... 61

- Introduction..... 61
- Calipers..... 62
- Inspection and Diagnosis..... 64
- Removing Calipers 65
- Repairing Calipers..... 66
- Installing Calipers..... 68

Chapter 2: Rotors 69

- Reading Micrometers 69
- Pulsating Pedal and Brake Fade 71
- Rotor Refinishing 75
- Machining Off Vehicle 76
- Machining On Vehicle..... 78
- Break-In/Burnishing..... 80

Unit 5 Power Assist Systems.....	81
Vacuum Assist.....	81
Hydraulic-Assist	82
Diagnosis	83
Unit 6: Wheel Bearings, Parking Brakes, Brake Lights and Circuits	86
Chapter 1: Wheel Bearings	86
Introduction.....	86
Non-Sealed Bearings	87
Sealed Bearings	89
Wheel Studs	90
Chapter 2: Parking Brakes & Brake Light Systems	91
Introduction.....	91
Dum Parking Brake	93
Disc Parking Brake	93
Testing	95
Drum Adjustment.....	96
Disk Adjustment	97
Brake Lights	97
Unit 7: ABS and Traction and Stability Control Systems	99
Chapter 1: Systems and Components	99
Introduction.....	99
ABS Components.....	101
Design Variations.....	103
Traction Control.....	104
Stability Control.....	104
Chapter 2: Antilock Brake System Diagnosis and Service.....	105
Normal Operation and Precautions.....	105
Diagnosis	106
Intermittent Problems	108
Servicing Components.....	108
Regenerative Braking.....	110

UNIT 1: BRAKES OVERVIEW

The following topics are addressed in this unit:

BRAKE SYSTEM FUNDAMENTALS

- Friction
- Tire Footprint
- Heat
- Weight and Speed
- Service Brakes & Parking Brakes
- Base Brake Components
- Brake Subsystems

BRAKE DIAGNOSIS PROCEDURES

- Work Orders
- Brake Diagnosis - Initial Steps
- Fluid Levels and Leaks
- Visual Inspection
- Test Drive (Road Testing)
- Removing Brake Dust
- Vehicle Lifting

CHAPTER 1: BRAKE SYSTEM FUNDAMENTALS

Automotive brakes are designed to slow and stop a vehicle by transforming **kinetic energy** (motion energy) into **heat energy**. Faster speeds, heavier vehicles, and quicker stops equal more heat.

FRICTION

Friction is the resistance to movement that results from two objects moving or rubbing against each other. There are two types of friction: **kinetic** and **static**.

- **Kinetic friction** occurs between two objects, one of which is moving. Kinetic friction always produces heat. The more kinetic friction produced, the more heat produced. Automotive braking systems use kinetic friction to convert the energy of a moving vehicle into heat.
- **Static friction** occurs between two objects that are stationary. Automotive braking systems use static friction to hold a vehicle while it is parked. Static friction produces no heat.

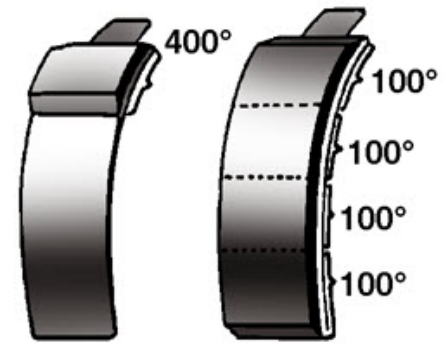

Various factors affect the amount of friction that is created between two surfaces but generally, the rougher a surface is, the more friction it will produce. Extremely rough surfaces will therefore naturally create the most friction, but they also tend to wear down quickly. As a result, automotive Brake Systems use relatively smooth surfaces to avoid rapid wear. However, in order to compensate for the reduced friction of their smooth surfaces, automotive brakes must be applied with a greater amount of pressure to work properly.

As a rule, the greater the pressure between two surfaces, the more friction they will produce. Therefore, the greater the pressure applied to the brakes, the greater their stopping power will be.

On **Drum Brake** systems, **Brake Shoes** are applied to Brake Drums to create Friction while **Disc Brake** systems apply **Brake Pads** to Rotors to create Friction.

One of the Friction surfaces used on Brake Systems is the **Brake Lining** which is mounted on either a Brake Shoe or Brake Pad. Brake Linings produce Friction by directly contacting either a Brake Drum or Disc (Rotor).

Brake Lining material must be somewhat softer than the Brake Drums or Discs to insure that the Shoes and/or Pads wear rather than the Drums or Discs. Presently, most Brake Linings are made of organic materials, metallic particles, and other minerals which are bonded or riveted to metal backing plates.

Note: For years, asbestos was commonly used to make Brake Linings. However, since asbestos has now been classified as a cancer-causing substance, federal law prohibits its use in Brake Systems.

When a Brake Lining is applied to a Drum or Disc, it is important that the proper amount of Friction is produced in order to ensure that the Brakes are effective. Consider the following:

- If the amount of Friction is too great, the brakes may be “grabby” or overly sensitive. Overly sensitive Brakes can cause a vehicle to skid.
- If the amount of Friction is too low, then Brake application will require excessive pressure. Applying the Brakes using excessive pressure can create excessive Heat that could result in Brake Failure.

TIRE FOOTPRINT

The point where a vehicle’s tire contacts the road is called the **Tire Footprint** or **Contact Patch**. This ‘Footprint’ is the only place where there is Braking Friction between the Tire and the Road. In general, the larger a tire’s Footprint is, the greater its stopping ability will be. Changes in the Friction of a Footprint due to tire size, tire condition, road surface condition, or substances on the surface (water, ice, snow, dirt, etc) will all affect a vehicle’s ability to stop.

Typically, the wider a tire is the larger its Footprint will be, and the more stopping power it will have. However, it is important to realize that the wider a tire is, the more Braking Power will be needed to stop the vehicle.

Excessive vehicle weight and/or incorrectly inflated tires can distort a tire’s Footprint and reduce its hold on the road. Tires that cannot hold the road will reduce a vehicle’s ability to stop.

Note: To control a vehicle, Friction must occur at the Tire Footprint. If this Friction is lost, the vehicle will be out of control.

Tires will grip the road more securely and stop better when the wheels are turning. Therefore, ‘locking up’ the Brakes will decrease a vehicle’s ability to stop.

Typical Tire Footprint



Tire Footprint From Wider Tire

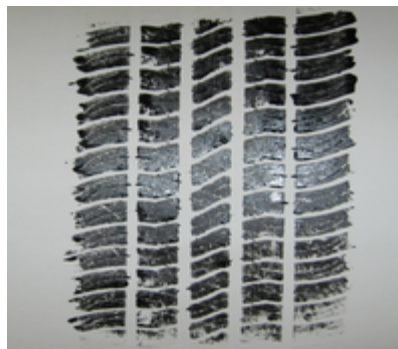

HEAT

As stated before, it is the Friction of converting Kinetic Energy to Heat Energy that makes vehicles stop. The problem is; what do we do with all of the Heat once it is created?

The reason we want reduced Heat in Brake Systems is that the hotter the surface is between two objects, the less Stopping Friction will be produced. Too much Heat in a Brake System will reduce the amount of Friction produced, which will reduce the stopping ability of the Brakes. This phenomenon is called **Brake Fade**.

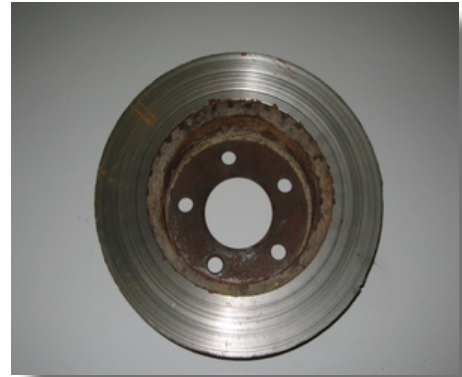

To prevent Brake Fade, all of the Heat that a Brake System creates must be dissipated as quickly as it is created. Since Brake Systems can store little or no Heat, their Friction Surfaces must be made of materials that can conduct Heat easily. Braking System components that produce Friction (Brake Shoes or Brake Pads) are also designed so that the passing air will cool them.

Therefore, the Brake Lining material, and the surfaces that it contacts, must have the following characteristics:

- Brake Drums or Discs must conduct Heat easily,
- Hold their shape under extremely high Heat,
- Withstand rapid temperature changes,
- Resist warping and distortion,
- Wear well in general

Because of those factors, Brake Drums and Discs are typically constructed of iron or steel combined with aluminum.

Remember the following:

- If Brakes create more Heat than they can dissipate, braking effectiveness will be reduced.
- Excessive Heat can cause the bonding agents in a lining to melt and flow to the surface of a shoe or pad. Those bonding agents can then produce a 'glaze' on the lining surface which will further reduce the Brake's effectiveness and cause Brake Fading. Brake application will then require more pressure which will create more Heat and more glazing.

WEIGHT AND SPEED

VEHICLE WEIGHT

The more Weight a moving vehicle has, the more Kinetic Energy it has. Recall that Brake Systems convert Kinetic Energy into Heat Energy, so any increase in vehicle Weight puts a greater demand on the Brakes.

How much does Weight affect a vehicle's Braking? Consider that if a vehicle's Weight doubles, the amount of Kinetic Energy that the Brakes must convert to Heat Energy also doubles. That's a lot of Heat, and we already know what too much Heat can do to Braking effectiveness, don't we?

Because of the effect of Weight on Braking, always be careful never to overload any vehicle, especially a truck, where it is easier to do. Exceeding the Weight limit of any vehicle is actually 'overloading' the Brakes.

Note: Pulling a trailer essentially has the same effect on vehicle Braking as increasing the Weight of the vehicle itself. The exception to this would be if the trailer has its own Brake System. This is just one reason why you should always slow down when towing.

VEHICLE SPEED

Vehicle Speed also affects Braking, but to a much greater degree than Weight. How much more? Consider that when the Speed of a vehicle doubles, the Brakes must convert, not double, but four times the amount of Kinetic Energy into Heat Energy.

With this information it is easy to see how a combination of High Speed and excessive Weight could easily push a vehicle's Brake System beyond its performance limit, and result in a serious loss of Stopping Power.

SERVICE BRAKES & PARKING BRAKES

Automotive Brake Systems fall into two major categories: **Service Brakes** (Hydraulically Operated) and **Parking Brakes** (Cable or Electrically Operated).

Master Cylinder and Brake Lines

Service Brakes are designed to stop a vehicle that is in motion while a Parking Brake is intended to hold the vehicle while it is parked.

Note: Always remember that a Parking Brake isn't designed to stop a moving vehicle and is not an Emergency Brake!

Note: Parking Brakes often, but don't always, use the same Friction surfaces as the Service Brakes.

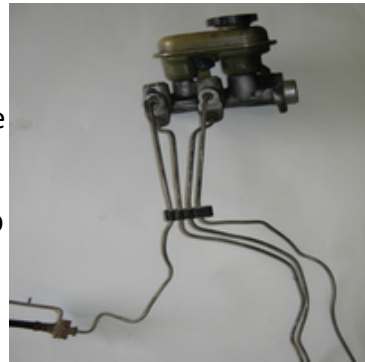

BASE BRAKE COMPONENTS

Base Brake components includes those parts that make up the Hydraulic Brake System found on all vehicles. The term "Base Brakes" will not include Antilock Brake or Traction Control systems.

Brake Light



Base Brake components include:

- Brake Pedal and Linkage
- Power Brake Boost System (Vacuum or Hydraulic)
- Master Cylinder, Lines, and Hoses
- Brake Rotors and Pads
- Brake Drums and Shoes
- Brake Balance Controls (Proportioning Valves and Metering Valves, if equipped)
- Red Brake Warning and other Warning Light Systems
- Parking Brake Pedal and Linkage(s)

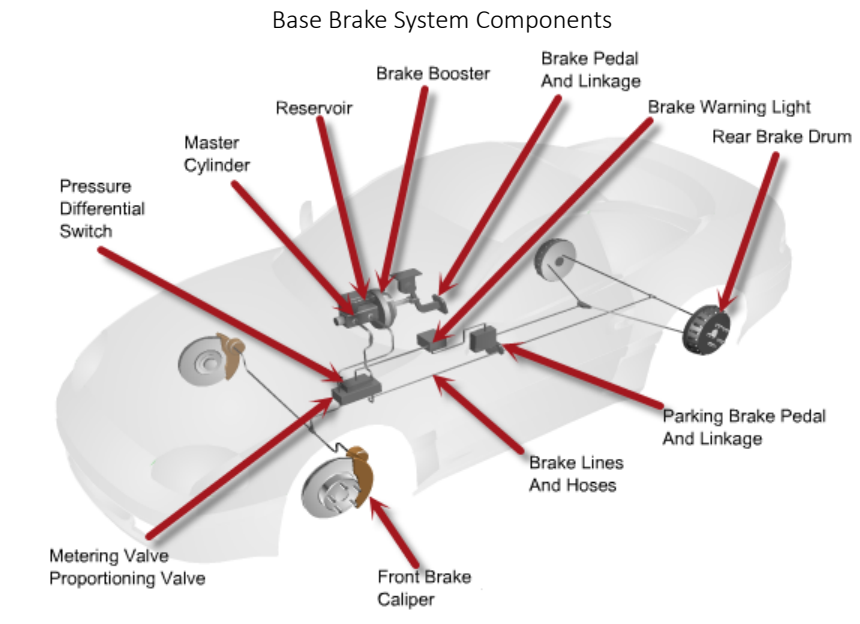

BRAKE SUBSYSTEMS

Automotive Brake Systems can be broken down into several different sub-systems:

- Apply System
- Boost System
- Hydraulic System
- Wheel Brakes
- Balance Control System
- Warning System

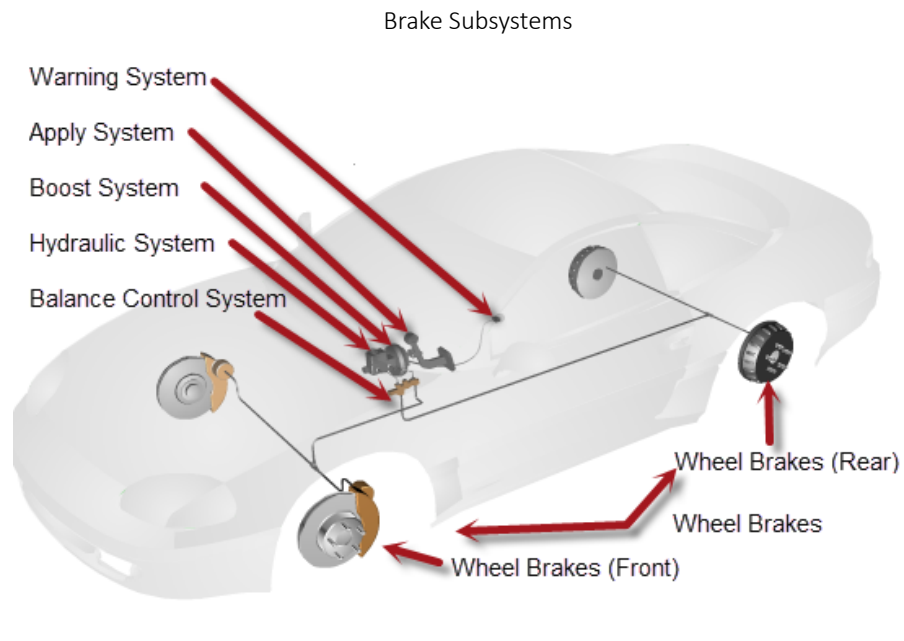

CHAPTER 2: BRAKE DIAGNOSIS PROCEDURES

Identify all service precautions, and review TSBs related to the vehicle's braking system. When completing the repair order, ask the owner for the vehicle's service history.

WORK ORDERS

The automotive technician needs to be familiar with the functions and components of a work order. The work order serves several functions.

- Itemizes the repairs by listing the cost of parts and labor
- Can be used to authorize the repair
- Has the necessary information on how to contact the owner and serves as documentation for future reference
- May also specify limited warranties and liabilities of the shop
- May serve as a reference for recent service history for warranty or legal purposes



A work order typically has the following components.

- Customer name, address, and phone number (home or work with extension number)
- Date
- Invoice number
- Year, make, model, vehicle identification number (VIN), and mileage of the vehicle
- Name/initials of the service writer and technician
- Customer authorization signature to allow repairs
- Description of customer concern
- Vehicle service history information
- Related technical service bulletins (TSB)
- Technician's notes that includes diagnostic procedures performed, the results of diagnosis, and any important observations or remarks
- Component or system defect responsible for the concern
- Service performed to successfully correct the concern
- Labor procedures and costs based on the parts and labor estimation guides
- Outside labor procedures and costs that include if a shop sent a particular part out to another shop for repairs
- Listing of each part that includes name, description, and cost
- Sales tax, which is usually calculated on parts only
- Total that represents the final price that the customer will pay for all charges related to the repair

Work orders may be handwritten or prepared by entering codes in a computer terminal and then printed.

Depending on the part, the following information may be required for ordering repair parts.

- Make, model, and model year (found on the driver's side door jamb) of the vehicle
- VIN
- Engine information that includes engine size, in cubic inches or liters, the number of cylinders, and the type of fuel system
- Wheelbase
- Number of doors

BRAKE DIAGNOSIS

Diagnosing Brake Problems can be simplified by following a few basic steps:

- Listen to the Customer
- Verify the Complaint
- Perform a Visual Inspection
- Conduct a Brake Pedal Check
- Test Drive (before and after repairs)

It is very important to verify the Customer's Concern before beginning diagnosis of a Brake System. Have the customer describe the Brake System Concern while paying careful attention to what they are describing. Ask the customer the following series of questions and record their answers.

- When did the concern first occur?
- Is the concern Continuous or Intermittent?
- Is the Brake or Antilock Brake System Warning Light ON or Flashing?
- What are the Driving Conditions when the concern occurs?
- What is the recent Service History of the vehicle?
- Is the vehicle making any unusual Noises?
- Does the vehicle pull during Braking?
- Based on the answers to the questions, determine the next step in the Diagnostic Process for this vehicle.



FLUID LEVELS AND LEAKS

Fluid levels - remove the master cylinder reservoir cover and inspect the fluid level in both chambers. Some reservoirs have both hot and cold fill level indications; make sure you use the correct level. Low fluid level in either chamber could be either the result of normal brake lining wear or it could indicate an external leak.

External leaks - visually check the master cylinder, calipers, and/or wheel cylinders for leaks. Fluid will be visible on the face of the power brake booster if the master cylinder is leaking from its rear seal.

The bottom of the caliper will be damp with fluid if a disc brake is leaking.

The bottom of the backing plate will be damp with fluid if a wheel cylinder is leaking.

Note: Leaking calipers or wheel cylinders can coat the brake pads or shoes with brake fluid and cause complaints such as wheel lock up, brake squeal, pulling and ineffective braking.

CAUTION: Leaks should be repaired before driving any vehicle.

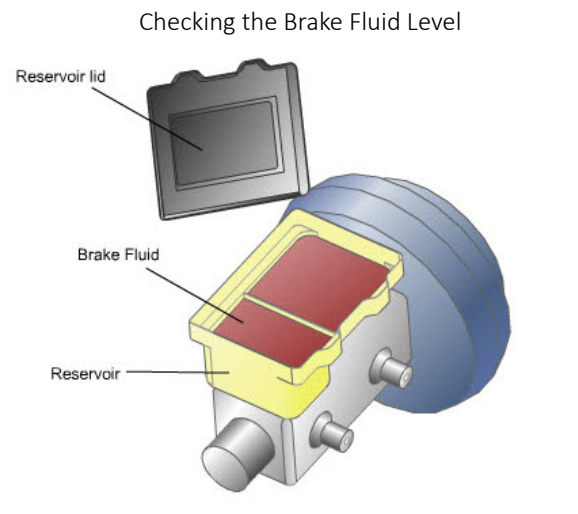

Master Cylinder Rear Seal Leak

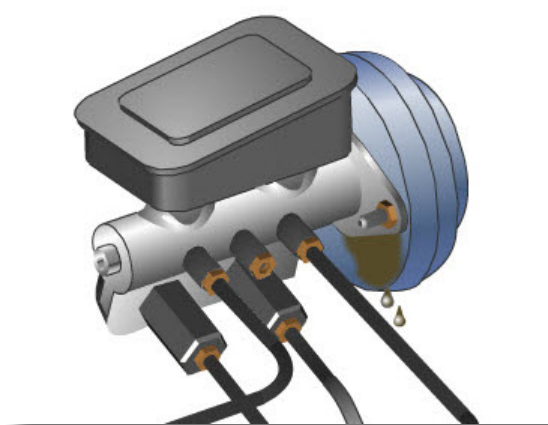

Wheel Cylinder Leak

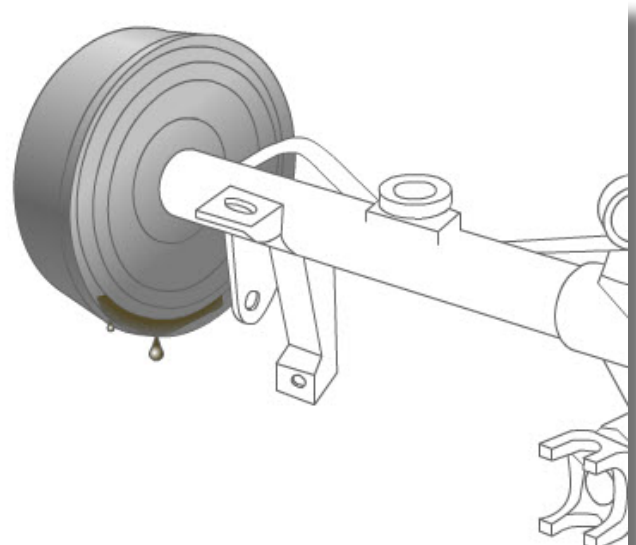

- Parking brake operation - With the key on and the engine off, engage the parking brake. The brake should apply with approximately half travel of the lever or pedal and the brake warning light should turn on. Deactivate the parking brake and it should release immediately. The lever or pedal should return to the release position and the warning light should turn off. Any problems with the engagement or release of the parking brake could indicate a binding linkage.
- Brake warning light - With the key on and engine off (parking brake disengaged), if a brake warning light comes on, with or without applying the service brakes, it could indicate a hydraulic failure in the system.

CAUTION: Repair the hydraulic system before driving the vehicle.

DETAILED VISUAL INSPECTION

Before starting Brake Work on any vehicle, a thorough Visual Inspection should be completed using a Checklist similar to the one on the following page.

Parking Brake Adjustment



Parking Brake Adjustment



Worn Brake Rotors



Worn Brake Rotors



VISUAL INSPECTION CHECKLIST

Component	Inspect For:	Corrective Action:
Brake Lines and Hoses	Leaks	Repair or Replace as Necessary
	Crimps or Restrictions	
Parking Brake Cables	Excessive Slack	Clean, lubricate, adjust, or replace as necessary
	Corrosion that could prevent brake application or release	
Parking Brake Operation	Proper Operation	Clean, lubricate, adjust, or replace as necessary
	Wheels Rotate (parking brake engaged)	
	Wheels cannot be rotated without excessive drag (Parking Brake disengaged)	
Brake Linings	Excessive Wear	Replace
Brake Hardware and Hold-downs	Damage, wear, or corrosion	Replace
	Missing Components	Replace
Brake Rotors	Wear (reduced thickness)	Compare to Specifications
	Deep scoring or scratches	Machine or replace as indicated
	Thickness Variation	
	Lateral Runout	
	Excessive heat checking	
Brake Drums	Wear (excessive diameter)	Compare to Service limit Specifications
	Deep scoring or scratches	
	Taper (bell mouth)	
	Out of round	
	Excessive heat checking	

TEST DRIVE

A road test is the only reliable way to check the stopping abilities of the brake system. Road test all vehicles immediately after any brake work.

PROCEDURE FOR PREPARING A VEHICLE FOR A ROAD TEST

- Make sure the brake pedal is more than 1.5 in from the floorboard. The brake pedal should feel solid when depressed.
- If the vehicle is equipped with power brakes, start the engine while depressing the brake pedal. The pedal should move down slightly as the vacuum increases. Also make sure that other types of power-boosting devices within the brake system are operating correctly.
- Set the parking brake and try to move the vehicle. Make sure the parking brake can hold the vehicle. Release the parking brake and note the vehicle's freedom of movement. The vehicle should move freely.
- Let the vehicle begin to move very slowly and then apply the brakes. Make sure the brakes have adequate stopping power before driving the vehicle further.



PROCEDURE FOR ROAD TESTING THE VEHICLE

Note: Conduct road tests in areas where there is little or no traffic.

- Accelerate to about 5 mph and gently apply the brake pedal.
- Make sure the brakes work effectively and smoothly. The vehicle should not pull in either direction during braking. There should be no unusual noise or brake pedal pulsation.
- Accelerate to about 30 mph and apply the brakes firmly.
- Make sure there is no wheel lockup, pulling, or unusual noise.

CAUTION: During a road test, never apply the brakes hard enough to lock up the wheels.

ROAD TEST FLOWCHART

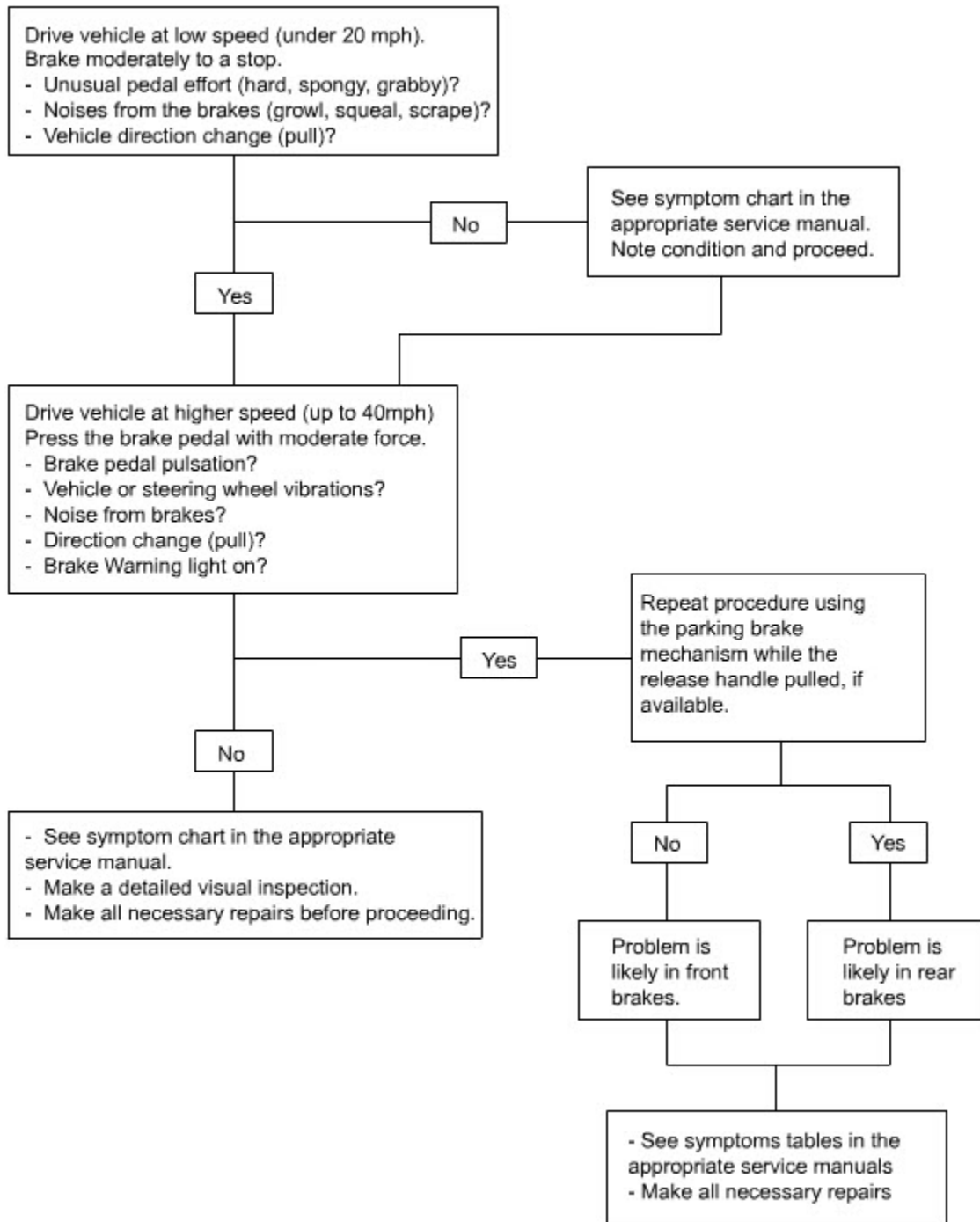

REMOVING BRAKE DUST

As a vehicle's Brake Shoes and Pads wear, the lining material creates dust that must be removed as part of performing a Brake Job. Due to federal regulations, it is no longer an acceptable practice to just blow out the dust with an air hose. All brake dust must now be captured by special equipment and disposed of properly. The automotive industry has available two methods of capturing dust: **Dry** and **Wet**.

THE DRY METHOD OF DUST CAPTURE

- The Dry Method requires placing a metal and plastic enclosure over the Brake to be repaired. This enclosure will contain built-in rubber gloves with which the Brake Parts can be handled during cleaning.
- Using the built-in gloves, dust is blown from the Brakes with an air hose (within the enclosure) where it will remain contained in the enclosure until a special vacuum cleaner removes it. The Brake Dust can then be collected in a plastic bag for disposal.

THE WET METHOD OF DUST CAPTURE

- The Wet Method also requires placing a metal and plastic enclosure over the Brake. As in the Dry Method, this enclosure contains built-in rubber gloves with which the Brake Parts can be handled during cleaning.
- Using the built-in gloves, a specially designed Brake Parts Washer (see image at right) is used to spray the Brake Parts within the enclosure. The Fluid washes the dust from the Brake Parts and once again, a special vacuum cleaner collects the dust and fluid in a holding tank. The Brake Dust can then be collected in a plastic bag for disposal.

CAUTION: Although Federal law has banned the use of asbestos in Brake Linings for many years, it is still classified as a cancer-causing substance. If a technician ever finds himself working on a vehicle with Asbestos-containing components, care must be taken to never breathe the Asbestos or allow it to escape into the air.

CAUTION: Federal law also dictates precise procedures for disposing of captured Brake Dust. Always follow the proper procedures.

CAUTION: Never use a household vacuum cleaner to remove Brake Dust from an enclosure. A household vacuum cleaner cannot adequately filter the small particles.

CAUTION: If Brake Dust capture equipment is unavailable, or in poor working order, do not perform Brake or Clutch work.

Brake Washer



VEHICLE LIFTING

LIFTING A VEHICLE

To perform most brake work, it is necessary to lift the vehicle and work under the supported vehicle. When doing brake work, observe all safety rules regarding lifting a vehicle.

CAUTION:

- When lifting a vehicle, always use proper lifting equipment and observe all safety precautions.
- Never work under a vehicle that is supported by any type of jack or by blocks. Always use solid metal support stands or a lift that can support the entire vehicle by its frame.
- Never work under or around a vehicle supported by a bumper jack. Bumper jacks are especially dangerous.



UNIT 2: HYDRAULIC SYSTEM

The following topics are addressed in this unit:

INTRODUCTION TO THE HYDRAULIC SYSTEM

- Hydraulic Principles
- Master Cylinder
- Split Hydraulic Systems
- Balance Control Systems
- Servicing the Hydraulic System

BRAKE SYSTEM SWITCHES AND VALVES

- Brake Warning Light
- Master Cylinder Service
- Brake Pedal Free Height and Travel
- Brake Fluid
- Brake Bleeding
- Brake Lines and Hoses

CHAPTER 1: INTRODUCTION TO THE HYDRAULIC SYSTEM

HYDRAULIC PRINCIPLES

Automotive Base Brake systems operate using Hydraulic (fluid) Systems that follow **Pascal's Laws of Hydraulics**. Blaise Pascal was a French mathematician and scientist who discovered that when pressure is applied to a Fluid in an enclosed space, the Fluid will exert the same pressure equally in all directions.

Also, when put under pressure, fluids will not compress, produce any measurable Friction, or lose pressure when transferred through the Fluid.

A second hydraulic principle states that a relationship exists between:

- Force and Piston Area and
- Piston Travel and Piston Area

From the first principle, if a master cylinder generates 500 psi, it also transfers 500 psi to the pistons in each wheel cylinder (remember that fluid pressure remains constant).

In the second principle, when pressure from a one-square-inch master cylinder piston exerts 500 psi on a wheel cylinder piston, which also has one-square-inch surface area, the wheel cylinder piston transfers 500 pounds of force to the brake shoe (500 psi x 1 in. sq. = 500 lbs.).

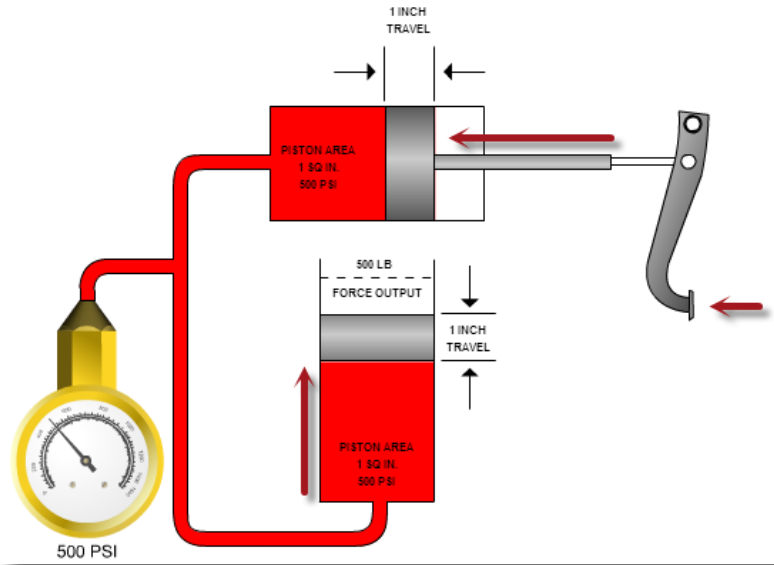

Note: As you continue your study of hydraulics, do not confuse Force (pounds) with pressure (pounds per square inch).

However, if the same one-square-inch piston exerts 500 psi on a second piston that has a two-square-inch area (see the second image), then the second piston will transfer 1,000 pounds of Force to the Brake Shoe or Pad (500 psi x 2 sq. in. = 1,000 lbs.)

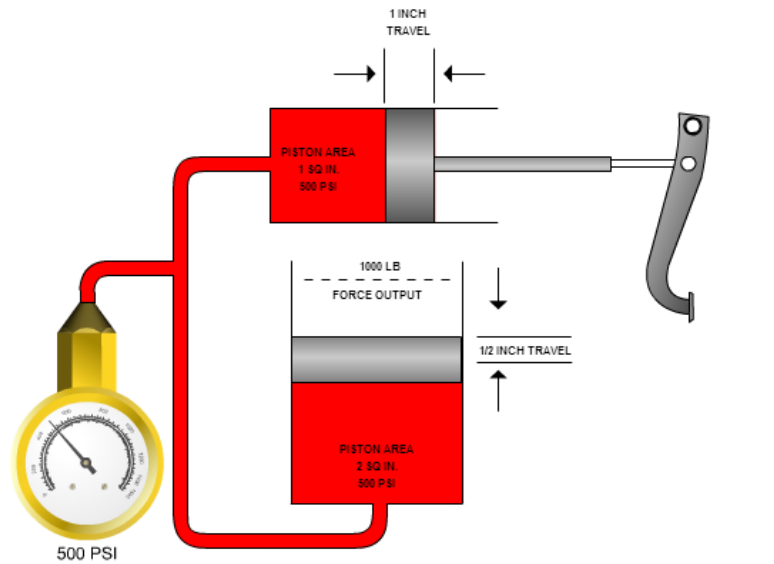

MASTER CYLINDER

The function of a **Master Cylinder** is to convert Mechanical Force from the Brake Pedal, Power Booster and Push Rod into Hydraulic Pressure. Hydraulic Pressure in this case is created by applying Mechanical Force to **Brake Fluid**.

Master Cylinders contain Pistons (2), Piston Seals, Return Springs and internal Brake Fluid Ports. They also have a Fluid Reservoir with a removable cap and a rubber seal to keep out dirt and moisture. In addition, most Reservoirs also have a **Low Brake Fluid Level Switch** to alert the driver of a Low Fluid condition.

Master Cylinder with Reservoir



THE MASTER CYLINDER IN ACTION

As you can see in this figure, there are two Pistons (primary and secondary) and two Springs inside the Master Cylinder. When the Brake Pedal is pressed, a Push Rod moves the Primary Piston forward which begins to build pressure in the Primary Chamber and Lines. As the Brake Pedal is depressed further, the increasing pressure between the Primary and Secondary Pistons forces the Secondary Piston forward and pressurizes the Fluid in the secondary circuit. If the brakes are operating properly, the pressure will be the same in both circuits.

Master Cylinder Operation

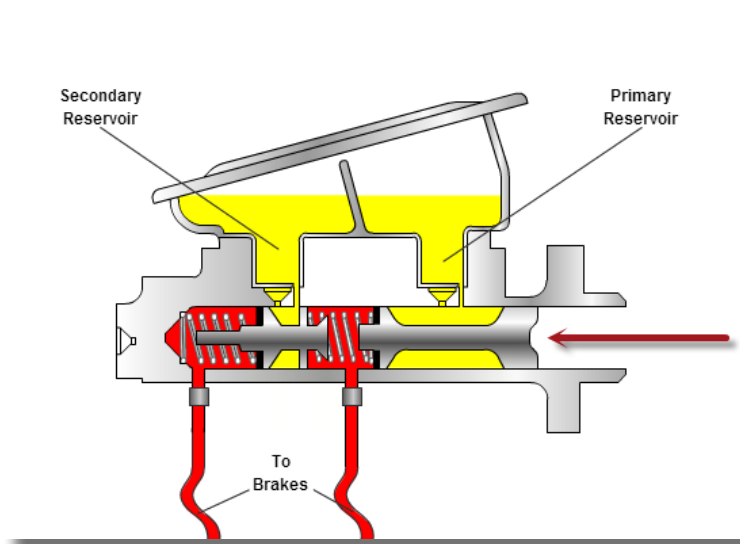

BRAKE CIRCUIT LEAK

If there is a leak in one of the Brake Circuits, that circuit will not be able to maintain pressure. The figure below shows what happens when one of the circuits develops a leak. In this example, the leak is in the Primary Circuit and pressure between the Primary and Secondary Pistons is lost. This pressure loss causes the Primary Piston to mechanically contact the Secondary Piston and the Master Cylinder now behaves as if it has only one piston. The Secondary Circuit will continue to function correctly, however the driver will have to press the Pedal further to activate it. In addition, since only two wheels now have pressure, the Braking Power will be reduced.

Master Cylinder with Leak

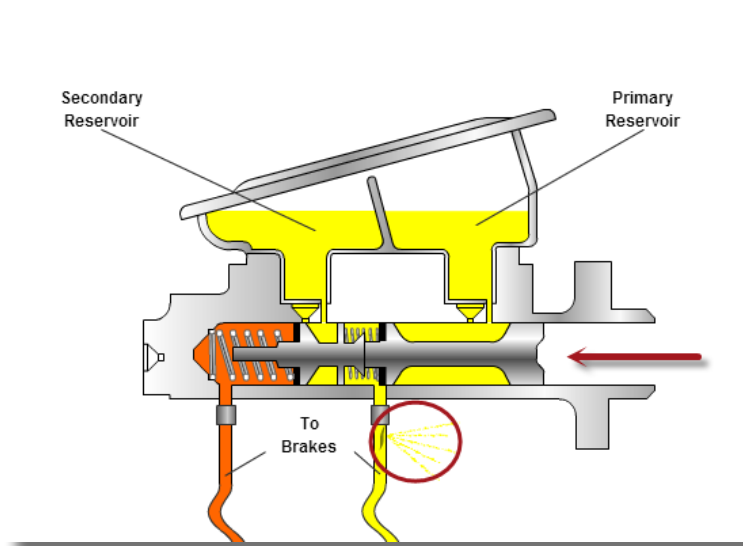

The following are basic leak types and indications:

- External Leaks - Brake Fluid can usually be seen running down the face of the Power Booster.
- Internal Leaks - the Brake Pedal will usually fall away when foot pressure is applied.

Refer to the applicable vehicle information for leak diagnostics and service procedures.

SPLIT HYDRAULIC SYSTEMS

For safety reasons, all modern automotive Brake Systems are designed with two separate and independent (split) Hydraulic Systems, or channels. In this way, the failure of one system due to a partial loss of Brake Pressure, will not result in complete Brake loss, even though Braking will still be greatly reduced.

The two Split System types are:

- Diagonally-Split — used on most Front Wheel Drive vehicles
- Front/Rear-Split — used on most Rear Wheel Drive vehicles

DIAGONALLY-SPLIT HYDRAULIC SYSTEM

In a **Diagonally-Split Hydraulic System**, the Left-Front and Right-Rear Brakes (LF/RR) are connected to one channel of the Master Cylinder, while the Right-Front and Left-Rear Brakes (RF/LR) are connected to the other channel of the Master Cylinder. This system is typically used on Front Wheel Drive vehicles because they have a front-heavy weight distribution and approximately 70% of the Braking occurs at the Front Brakes. That way, if one part of a Diagonal System fails, the overall Braking will only be reduced by 50% rather than by 70% if both Front Brakes were lost.

Diagonally-Split Hydraulic System

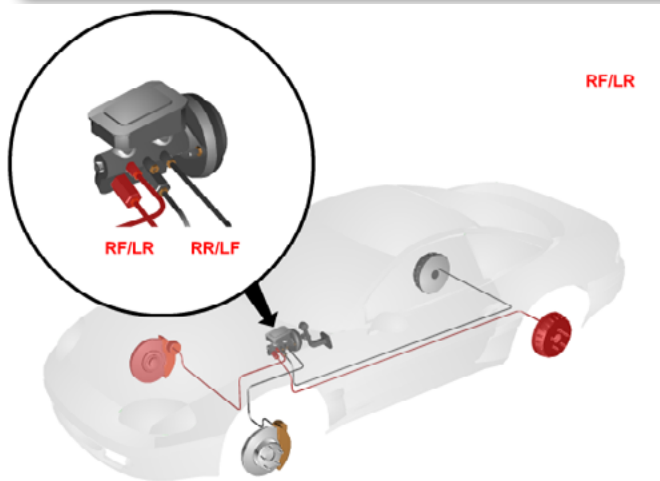
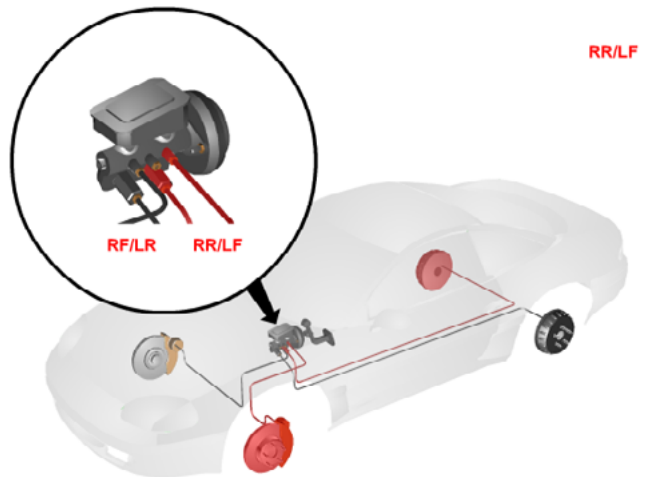

FRONT/REAR SPLIT HYDRAULIC SYSTEM

Front/Rear Split Hydraulic Systems are typically used on Rear Wheel Drive systems since those vehicles tend to have a more equal weight distribution, and therefore more equal Braking. In a F/R Split System both Front Wheel Brakes (LF/RF) work together on one Master Cylinder System (channel) while both Rear Wheel Brakes (LR/RR) work together on a separate Master Cylinder System.

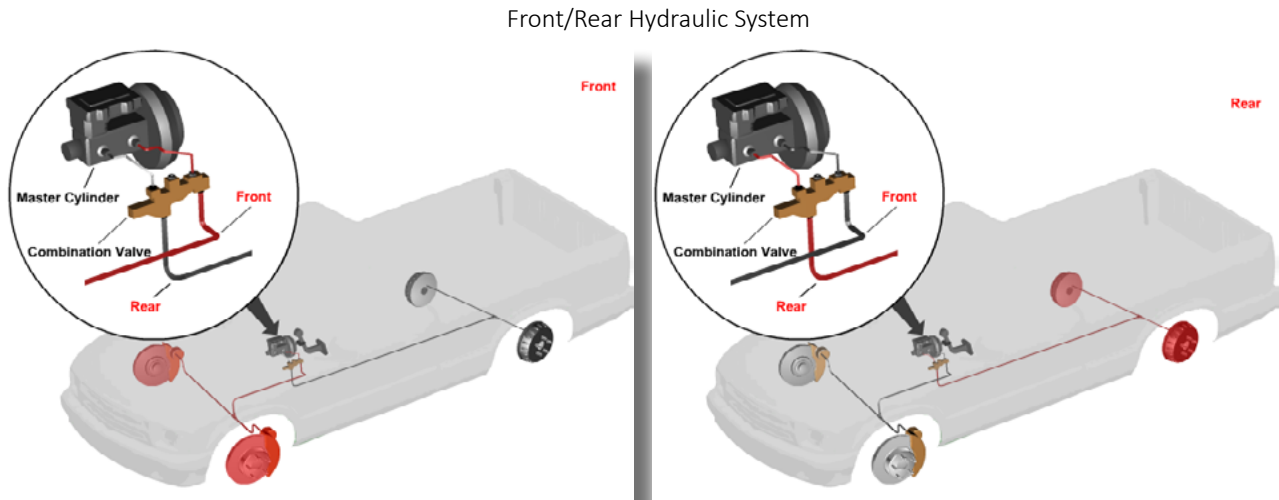

BALANCE CONTROL SYSTEMS

Many late model vehicles are equipped with Front Disc Brakes and Rear Drum Brakes. Those Disc/Drum arrangements require different pressures between the Front and Rear to ensure even braking. The following are some of the items to be aware of concerning this “Braking Differential”:

- Disc Brakes can apply at lower pressures than Drum Brakes.
- Metering Valves are used to prevent the Front Disc Brakes from applying before the Rear Drum Brakes.
- During heavy Brake application, the Rear Brakes can lock up, resulting in a skid and loss of vehicle control if the same Hydraulic Pressure is simultaneously applied to both the Front Disc and Rear Drum Brakes.
- Proportioning Valve(s) are used to prevent Rear Brake lockup by limiting Hydraulic Pressure to the Rear Brakes during heavy Braking.
- The Metering Valve and the Proportioning Valve are often housed in a single unit, called a Combination Valve, in many Rear-Wheel-Drive vehicles equipped with Front Disc and Rear Drum Brakes.
- Most vehicles are equipped with some form of Pressure Differential Valve and Switch which will activate a dashboard Warning Light if pressure is lost in either of the Hydraulic Channels. This switch is typically located in a Combination Valve or on the Master Cylinder.

CHAPTER 2: SERVICING THE HYDRAULIC SYSTEM

SWITCHES AND VALVES

➔ Brake System Switches and Valves

INSPECTING AND TESTING HYDRAULIC BRAKE SWITCHES AND BRAKE VALVES

CAUTION: Never attempt to repair a Pressure Differential Valve, Metering Valve, Proportioning Valve, or Combination Valve. If any valve is defective, replace it.

CAUTION: Always check and refill the Master Cylinder after testing or servicing a Hydraulic System.

CAUTION: Always make sure the Hydraulic System is free of air after Testing or Servicing.

WARNING LIGHT

➔ Brake Warning Light

The Brake Warning Light, located on a vehicle's instrument panel, indicates that either a Hydraulic Brake Channel has lost pressure, the Parking Brake is ON, or the Master Cylinder Fluid Level is low (some have a separate indicator for Low Fluid Level).

CAUTION: The Brake Warning Light may turn ON due to a faulty switch or a problem with the Parking Brake. If the Brake Warning Light comes on, make sure that both Hydraulic Brake channels have adequate pressure and are working properly before inspecting the Brake Warning Light Switch or Parking Brake.

Note: The Brake Warning Light is usually powered by an Accessory circuit and activates only when the Ignition Switch is ON. The Brake Light Switch typically controls this Warning Light by grounding the circuit.

TESTING A BRAKE WARNING LIGHT

To check a Brake Warning Light:

- Turn the Ignition Key to the ON position and observe the lamp.
- If the light turns ON then goes OFF, the system is functioning normally.
- If the light stays ON, continue the diagnosis.

Ensure that the Master Cylinder Reservoir is sufficiently full.

Locate the Parking Brake Warning Light Switch and ensure that the Brake Linkage is properly deactivating the Brake Warning Light Switch.

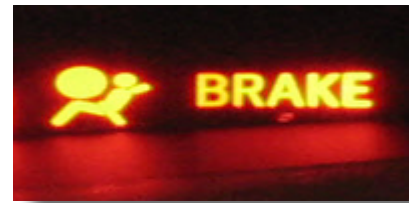

Parking Brake Warning Light Switch

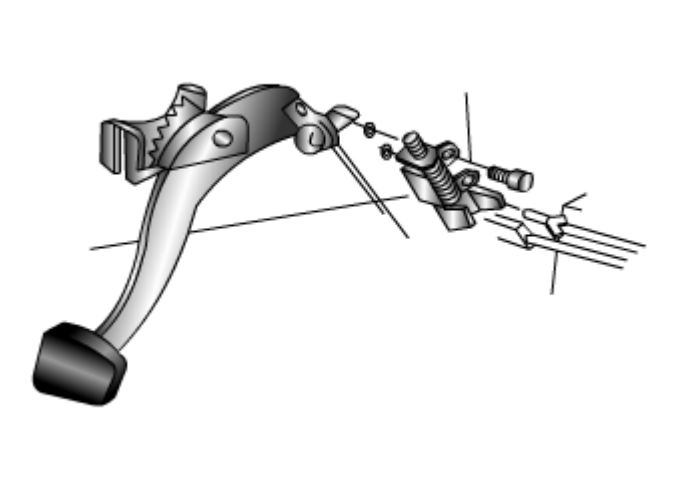

MASTER CYLINDER

➔ Master Cylinder Service

INSPECTING A MASTER CYLINDER

Note: The following are general procedures. Always consult the applicable service information when diagnosing a Master Cylinder.

Begin by checking the Master Cylinder Fluid Level and quality.

CHECKING A MASTER CYLINDER FOR EXTERNAL LEAKS

Thoroughly clean and dry the exterior of the Master Cylinder as well as the Brake Lines and fittings near it.

Pump the Brake Pedal at least 10 times and look for signs of leakage around the Brake Lines, Cap, or Power Booster mounting bracket.

Note: In Power Brake Systems, external leaks at the input rod end of the Master Cylinder, deposit Brake Fluid on the Power Booster. Therefore the Power Booster should be checked for traces of Brake Fluid.

CHECKING A MASTER CYLINDER FOR INTERNAL LEAKS

With the vehicle stopped, hold down the Brake Pedal and note if it slowly loses firmness.

If the Pedal regains firmness after it is released and pressed down again, there may be an internal leak in the Master Cylinder.

Note: A soft or spongy Pedal may indicate a leak in the Master Cylinder. The loss of firmness may also indicate an external leak in the Brake lines or Brake actuators.

To confirm the possibility of an internal Master Cylinder leak, have an assistant hold down the Brake Pedal and check for external leaks at the Wheel Cylinders, Calipers, Brake Lines, and fittings. If no leaks are found, the loss of firmness may indicate an internal leak in the Master Cylinder.

CHECKING THE OPERATION OF A MASTER CYLINDER

Place the Reservoir Cap loosely on the Master Cylinder.

Have an assistant quickly pump the Brake Pedal at least 10 times.

Have the assistant hold down the Pedal with medium pressure (25 lb to 35 lb).

Remove the cap from the Reservoir and have the assistant release the Brake Pedal. The Fluid should gush up noticeably (about 1/4 in) from the Reservoir. If the Fluid does not gush, air may be present in the System indicating that the System needs to be bled (emptied of air).

Master Cylinder



CAUTION: Always keep your face away from the Master Cylinder.

Note: If fluid still does not gush after the System has been bled, either the Master Cylinder has an internal problem or the Brakes are not releasing.

REMOVING, BENCH BLEEDING, AND REPLACING A MASTER CYLINDER

CAUTION: Always check and refill the Master Cylinder after Testing or Servicing Hydraulic System components.

CAUTION: Always make sure the Hydraulic System is free of air after Testing or Servicing Hydraulic System components.

REMOVING A MASTER CYLINDER

Disconnect the Hydraulic lines from the Master Cylinder.

Remove the bolts that hold the Master Cylinder to the Brake Booster and remove it from the vehicle.

Remove the Master Cylinder cap and drain as much Fluid from the Reservoir as possible.

Note: Some Brake Systems have Reservoirs that are mounted in a remote location and connect to the Master Cylinders by hose. These Reservoirs can be disconnected from the Master Cylinder and remain in the vehicle.

Some Reservoirs have only one chamber, with a separator, that feeds both Hydraulic Systems while others use separate Reservoirs for each Hydraulic Channel.

BENCH BLEEDING

Technicians should Bench Bleed all Master Cylinders immediately before installation since air can easily enter dual Master Cylinders and normal Bleeding does not always purge all of the air.

Bench bleeding a Master Cylinder

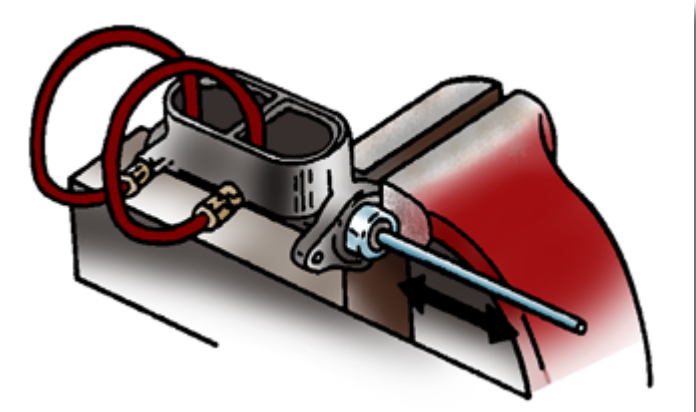

BENCH BLEEDING A MASTER CYLINDER

- Connect two short pieces of Brake line to the Master Cylinder outlet ports and direct the lines into the reservoir(s).
- Fill the Reservoirs with clean Brake Fluid making sure that the ends of the return lines are submerged.
- Using a short dowel, or other such tool, slowly pump the Master Cylinder piston until bubbles stop forming in the Reservoir.

To reinstall a Master Cylinder, simply reverse the removal procedure. After installation, add new Brake Fluid to the System, Bleed the Brakes, check and adjust the push rod if necessary, and test drive the vehicle.

BRAKE PEDAL

➔ Brake Pedal Free Height and Travel

DETERMINING BRAKE PEDAL FREE HEIGHT AND TRAVEL

CAUTION: Make sure to set and properly adjust the Parking Brake before performing this procedure.

Measure the distance between the floorboard and the top of the Brake Pedal Pad. This measurement is the Brake Pedal Free Height.

Note: On most vehicles, the Brake Pedal Free Height will be between 7 inches and 8 inches. Incorrect Free Height indicates worn, bent, or improperly installed parts. Free Height is not always adjustable.

Start the vehicle's engine and apply about 25 lb of pressure to the Brake Pedal. While applying pressure, remeasure the distance between the floorboard and the top of the Brake Pedal Pad.

The difference between the first and second measurements is called Pedal Travel. For Power Brakes, the Pedal Travel should be between 2 and 3 inches.

ADJUSTING BRAKE PEDAL TRAVEL

Excessive Brake Pedal Travel may indicate a problem with the Brake Pedal Push Rod. If it also has a spongy Pedal it may indicate that air is trapped in the System. Either way, the cause of excessive Brake Pedal Travel must be corrected.

Many Brake Systems have non-adjustable push rods. Therefore, when correcting for excessive Brake Pedal Travel on these Systems, you must first ensure that the Master Cylinder pistons return to their released position as the Brakes are disengaged. There should be a small amount of clearance between the push rod and the piston when the Brakes are not applied.

Parking Brake Warning Light Switch

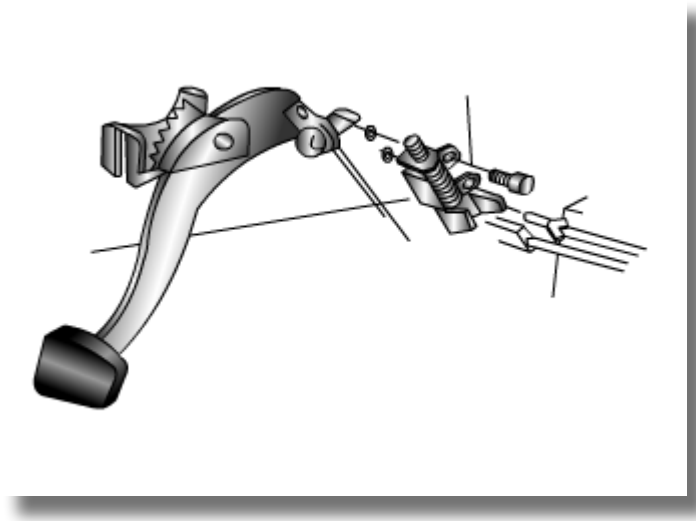

BRAKE PEDAL CHECK FLOW CHART

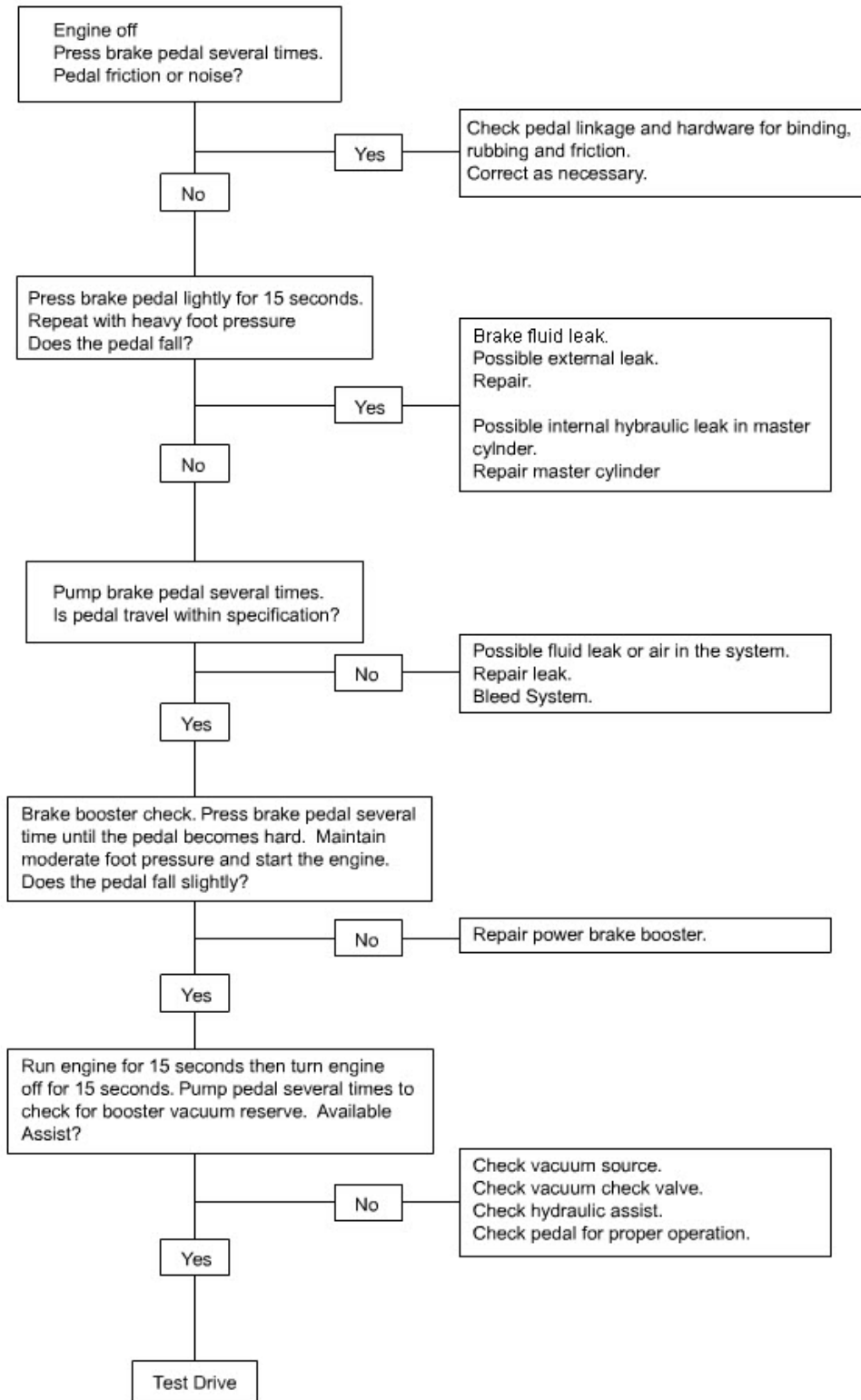

BRAKE FLUID

The specifications for all automotive Brake Fluids are defined by the Federal Motor Vehicle Safety Standards and are assigned Department of Transportation (DOT) numbers.

These specifications list the qualities that Brake Fluid must have such as:

- Free flowing at low and high temperatures
- A boiling point over 400 degrees F. (204 degrees C.)
- Low freezing point
- Non-corrosive to metal or rubber Brake Parts
- Ability to lubricate metal and rubber parts
- Hygroscopic - Ability to absorb moisture that enters the Hydraulic System

The four Brake Fluids that currently have assigned DOT numbers are: **DOT 3**, **DOT 4**, **DOT 5**, and **DOT 5.1**. DOT 3 and DOT 4 are polyalkylene-glyco-ether mixtures while DOT 5, and DOT 5.1 are silicone based. Almost all vehicles on the road use either DOT 3 or DOT 4 (after 2006 due to its higher boiling point). DOT 5 brake fluid is typically used in heavy machinery and vehicles that do not have Antilock Brake Systems. DOT 5.1 is more compatible with DOT 3 and DOT 4 type Systems, as well as Antilock equipped Systems, since it has less than 70% silicone (DOT 5 is greater than 70% silicone).

DOT 3 and DOT 4 brake fluid



Precautions must always be observed when working with Brake Fluids:

- Brake Fluid is toxic to the human body.
- Brake Fluid can damage painted surfaces.
- Brake Fluid contaminated with moisture, dirt, petroleum or other foreign material will damage the Hydraulic System internally.
- Only denatured alcohol or other approved cleaners should be used when cleaning Brake Hydraulic parts.
- Use only fresh, clean Brake Fluid (never reuse old Brake Fluid).
- Never mix Brake Fluids with any other fluids, including other types of Brake Fluid (e.g. DOT 3 and DOT 4).

STORING BRAKE FLUID

- In order to prevent contamination, Brake Fluid must not be exposed to the open air. Brake Fluid containers should be tightly capped and clearly marked.

CAUTION: DOT 3 and DOT 4 Brake Fluids are hygroscopic, which means they easily absorb moisture. Moisture is very harmful to Brake Fluid as it can lower the fluid's boiling point and reduce Brake performance. DOT 5 and DOT 5.1 are not hygroscopic since they contain silicone.

CAUTION: Brake Fluid is toxic to both humans and animals. Never store Brake Fluid in a manner that could allow it to be mistaken for food or drink.

- Do not punch air holes in Brake Fluid containers.
- Do not store Brake Fluid in extreme heat or cold.
- Do not store more Fluid than can be used in a month. Brake Fluid can be easily contaminated with moisture if stored for long periods.

HANDLING BRAKE FLUID

CAUTION: Ingesting Brake Fluid causes sickness and/or death. If Brake Fluid contacts the eyes, blindness may result. As a result, you should always avoid contact between Brake Fluid and your skin.

CAUTION: Brake Fluid damages automotive paint and other finishes.

- Never reuse Brake Fluid.
- Do not allow used Brake Fluid to collect in large amounts.
- Immediately and safely dispose of Brake Fluid that is contaminated, or even suspected of being contaminated.

SELECTING BRAKE FLUID

Always choose high-quality, DOT approved Brake Fluids that meet or exceed the manufacturer's specifications.

DOT 3 and DOT 4 Brake Fluid



DOT 5 Brake Fluid



ADDING BRAKE FLUID

CAUTION: Follow the proper procedures when adding Brake Fluid to Brake Systems to avoid bodily injury and/or damage to the Brake System.

- Park the vehicle on a level surface.
- Carefully clean all dirt from the Master Cylinder cover.
- Remove the Master Cylinder cover.
- Make sure the Fluid in the reservoir is clear and clean. If the Fluid has a rusty or milky appearance, drain it out, flush the lines and components, and Bleed the entire system.
- Add Fluid to the system until the level is within 1/4 inch of the top of the Reservoir.
- Restore the shape of the cover diaphragm or seal. It should have no holes and be in good condition. If the diaphragm has become soft or distorted, the Fluid is contaminated.
- Reinstall the cover.
- Check the vehicle to ensure that no Brake Fluid has spilled on painted surfaces. Use soap and water to clean Brake Fluid off of any painted surfaces.

CONTAMINATED BRAKE FLUID

Contaminated or poor-quality Brake Fluid may cause the Brake Pedal to feel soft or spongy after hard Braking.

Note: If the Brake Fluid is contaminated, drain and flush the lines and components, replace all the rubber parts, and refill the Brake System.

Moisture in the Brake Fluid can boil and form gas bubbles in the Wheel Cylinders or Calipers. Those bubbles can easily compress and cause the Pedal to feel soft or spongy.

Also check for the following problems if the vehicle has a spongy or soft Pedal:

- Soft spots that can cause the hoses to swell under pressure. If soft spots are found, replace all hoses and check for contaminated Fluid.
- Check for air in the Hydraulic System. If air is found, Bleed the System.

BRAKE BLEEDING

Any time a Brake Hydraulic System is opened to the atmosphere for repairs or leakage, the system must be Bled to remove the air. Unlike Brake Fluid, air is compressible and can cause a spongy Brake Pedal, Brake pull, or ineffective Brake application.

The three most commonly used methods for Bleeding Brakes are:

- Manual Bleeding
- Vacuum Bleeding
- Pressure Bleeding
- Master Cylinder Bleeding

Bench Bleeding a Master Cylinder

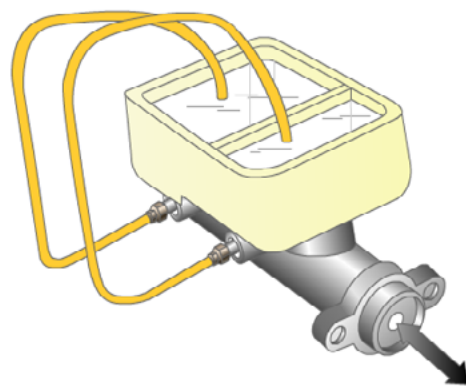

It is always a good idea to Bench Bleed a Master Cylinder after servicing or before installing/reinstalling it on a vehicle. The procedure for Bench Bleeding was covered previously in the **Master Cylinder** section.

BLEEDING ORDER

One of the oldest adages in the automotive service industry involves Brake Bleeding. The old saying is that you should Bleed the Brakes starting with the Wheel farthest from the Master Cylinder and move progressively closer with each successive Wheel. While there is some truth to this adage, it is no longer as universally applicable as it once was.

Before Front Wheel Drive vehicles became commonplace, most vehicles had Rear Wheel Drive and Front/Rear-Split Brake Systems (at least after the advent of Dual Piston Master Cylinders). So, technicians would Bleed the Right Rear first, since it is the longest Brake line, and then move to the Left Rear. After the Rears were clear of air, the Fronts would be Bled starting with the longest line (Right Front). This System is still applicable today for vehicles with Front/Rear (RWD) Split Systems, although it does not apply to Diagonally-Split Systems (mostly Front Wheel Drive) because the Right Rear and Left Rear Brakes are on separate Systems.

If the procedure above is used on a Diagonally-Split System and the Right Rear Brake is Bled followed by the Left Rear, then the Left Front Brake portion, which is only half Bled (Right Rear is done) will tend to aerate, or make bubbles, in the fluid as the Pedal is pressed to Bleed the Left Rear. Once you have bubbles in the Fluid, it can be extremely difficult to get the lines clear, and you may have to wait for the air and the Fluid to separate again before continuing.

So what is the proper Bleeding order to use? It depends on the vehicle. If it is a Front/Rear-Split System, start with one of the Rear Brakes (it really doesn't matter which, but most people start with the Right Rear), then move to the other Rear Brake. That will completely Bleed that System (the Rears). Then Bleed the Front Brakes. Again the order is really unimportant. If the vehicle has a Diagonally-Split System you may begin wherever you like - but whichever you do first, the opposite Brake must be next to prevent the possibility of aeration. If the Right Rear is first, the Left Front must be next. Start with the Right Front? Then the Left Rear is second. Most seasoned technicians will typically go from Right Rear to Left Front then from Left Rear to Right Front. That is usually a good idea since a consistent procedure helps to avoid errors.

Before we finish this section, a note on Antilock Brake Systems. Because of the nature of some ABS systems, certain vehicles will require a specific Bleeding order to help ensure that all of the air is removed from the ABS unit. If that is the case, follow the manufacturer's instructions. In addition, although the steps listed here do not include a specific process for bleeding ABS-equipped vehicles, 'cycling' the ABS unit with a scan tool is often a part of a proper Bleed procedure. Again, always refer to the applicable service information.



MANUAL BLEEDING

The Manual Brake Bleeding process requires two technicians; One to press and hold the Brake Pedal and a second to open/close the Bleeder Valves.

Note: Do not allow the Master Cylinder Reservoir to run out of Fluid, otherwise air can be drawn into the System.

Note: A Valve depressor tool may be needed to Bleed the Front Disc Brake Calipers on vehicles with Metering Valves.

MANUALLY BLEEDING A BRAKE SYSTEM

Note: This is a general procedure, consult your service information for any specific procedure requirements.

Use proper lifting equipment, and procedure, to raise the vehicle.

Make sure that all Bleeder Valves are free and clean. Remove and clean the Valves as necessary.

Add clean, new Brake Fluid to a clear glass jar until it is half full.

Install a six-point boxed-end Bleeder Wrench on the first Bleeder Valve.

Connect one end of a transparent Bleeder Hose to the Bleeder Valve making sure the other end of the hose is submerged in the Brake Fluid jar.

Override the Metering Valve, if needed.

Have an assistant press the Brake Pedal slowly (Do not 'pump' the pedal) and hold it there.

Open the Bleeder Valve about one-half turn and observe the Fluid flowing into the jar. The Brake Pedal will drop to the floor when the Bleeder Valve is opened. Make sure the assistant does not release the Pedal before the Bleeder Valve is closed.

Close the Bleeder Valve.

Note: To prevent air from getting sucked into the Brake System, the Bleeder Valve must be closed completely before the Brake Pedal is released.

Release the Brake Pedal.

Repeat these steps until the Fluid that flows into the jar is clear and free of air bubbles. Remember to close the Valve completely each time the Brake Pedal is released.

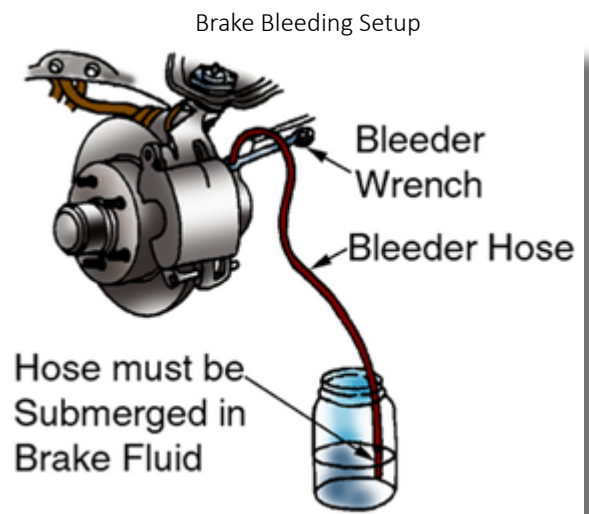

Once the released Fluid is clean, go to the next wheel.

Repeat the procedure until the Brake System is completely Bled.

Note: Make sure that the Master Cylinder Reservoir remains full throughout the Bleeding procedure. If at any point the Reservoir runs dry, start the procedure again.

Remove the Metering Valve Tool, if used.

Check the System for leaks.

Lower the vehicle and top the Fluid Level in the Master Cylinder Reservoir.

Test the Brakes to make sure the Pedal is firm before driving the vehicle. If the Pedal feels spongy or soft, repeat the entire process.

Brake Bleeding Setup

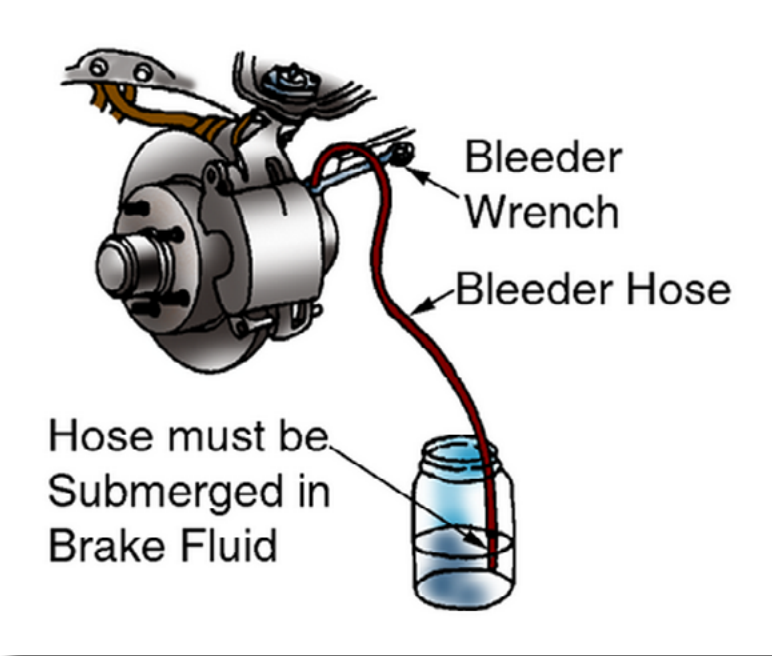

VACUUM BLEEDING

Vacuum Bleeding requires a device called a Vacuum Brake Bleeder, which is essentially a pump. A Vacuum Brake Bleeder can use either compressed air or a hand pump as a power source. Read the manual accompanying the Vacuum Bleeder for proper operation.

VACUUM BLEEDING BRAKES

Note: This is a general procedure. Consult the applicable service information before beginning. This procedure does not apply to, and should not be used with, Antilock Brake Systems.

Note: Vacuum Bleeding is typically not recommended for vehicles equipped with Antilock Brakes as it does not always completely purge the ABS valve body.

Use proper lifting equipment, and procedure, to raise the vehicle.

Make sure all Brake Bleeder Valves are free and clean. Remove and clean the Valves as necessary.

Hand Pump Type Vacuum Bleeder



VACUUM BLEEDING A BRAKE SYSTEM

Connect a compressed air supply or hand pump to the Vacuum Bleeder.

Connect a transparent Bleeder hose from the Vacuum Bleeder to the first Bleeder screw in the Bleeding sequence.

Override the Metering Valve, if needed.

Vacuum bleeding



Open a Bleeder Valve and observe the Fluid as it runs down the clear plastic hose. As soon as the Fluid runs clear, close the Bleeder Valve.

Note: Make sure that the Master Cylinder Reservoir remains full throughout the Bleeding procedure. If at any point the Reservoir runs dry, you must start the procedure again.

Repeat the Bleeding procedure on each of the other Brakes following the proper sequence. Top off the Reservoir between Brakes.

Remove the Bleeding equipment and check the Brake System for leaks.

Remove the Metering Valve Tool, if used.

Check the System for leaks.

Lower the vehicle and top the Fluid level in the Master Cylinder Reservoir.

Test the Brakes to make sure the Pedal is firm before driving the vehicle. If the Pedal feels spongy or soft, repeat the entire process.

PRESSURE BLEEDING

Pressure Bleeding is a process that uses air Pressure to force Brake Fluid into a Brake System rather than using Master Cylinder Pressure (manual bleeding) or Vacuum (vacuum bleeding). It is often the preferred method for Bleeding Brakes since one person can do the job alone and the Master Cylinder Reservoir does not have to be repeatedly refilled during the process.

Typical Brake Pressure Bleeder

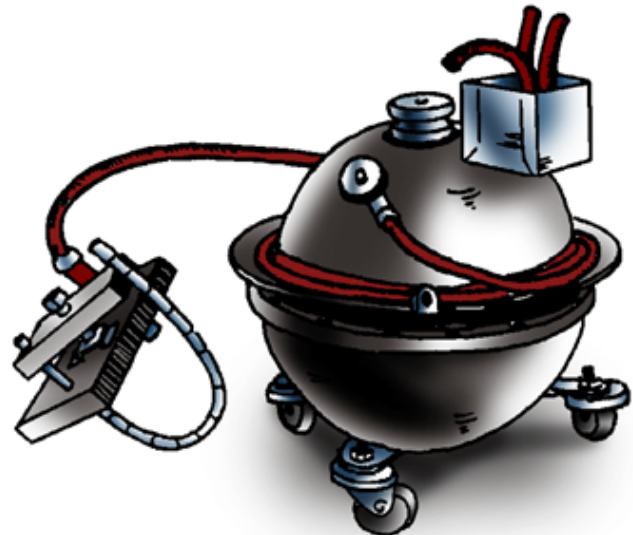

Pressure Bleeding uses a device called a **Pressure Bleeder** which is a special tank that is divided into two chambers separated by a rubber diaphragm. The upper chamber is filled with clean fresh Brake Fluid while the lower chamber is pressurized with air. The rubber diaphragm keeps the Brake Fluid separated from the air.

Brake Pressure Bleeder Internal View

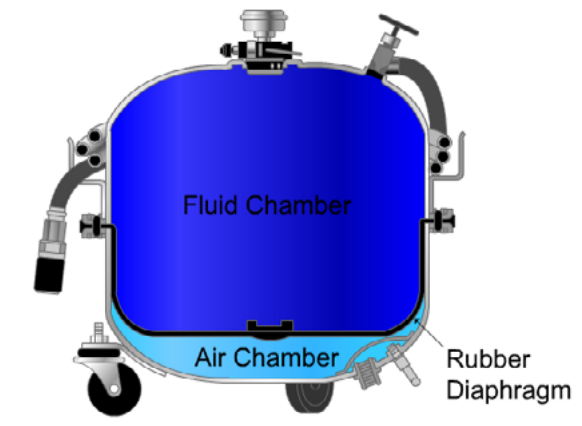

Pressure Bleeder with Hose and Master Cylinder Adapter

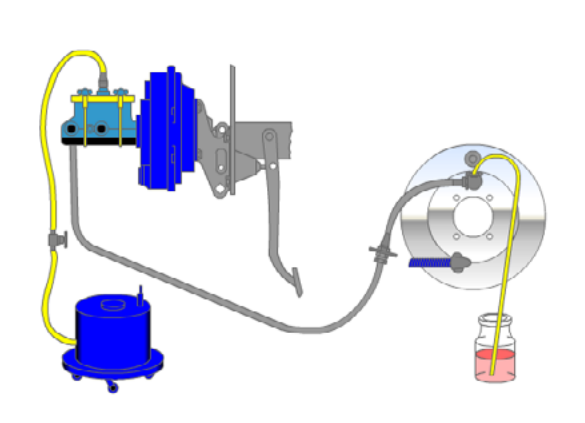

A Pressure Bleeder is attached to a Master Cylinder using a special adapter that seals the two together to prevent Brake Fluid from leaking out of the system or air leaking in.

PRESSURE BLEEDING A BRAKE SYSTEM

Note: This is a general procedure. Consult the applicable service information before beginning.

Note: Always read and follow the directions for the specific Pressure Bleeder being used. Also, use only clean Brake Fluid and compressed air.

CAUTION: Never overcharge a Pressure Bleeder.

Use proper lifting equipment, and procedure, to raise the vehicle.

Before Pressure Bleeding a Brake System, fill the Pressure Bleeder with clean Brake Fluid (DOT 3 or DOT 4 as required) and charge the Air Reservoir to the manufacturer's recommended Air Pressure. Fill the Master Cylinder Reservoir to the proper level, usually about one quarter (1/4) inch from the top. Install the Bleeder Adapter to the Master Cylinder Reservoir and attach the Supply Hose from the Pressure Bleeder to the Adapter.

Make sure that all Bleeder Valves are free and clean. Remove and clean the Valves as necessary.

Override the Metering Valve, if included in the system, by applying a Metering Valve Tool to activate the Valve's plunger.

Attach a transparent Bleeder Hose to the Wheel Cylinder Bleeder Valve and extend the end of the Hose into an empty container.

Open the Supply Valve in the Pressure Bleeder Hose.

Open the first Bleeder Valve one-half turn, or more, and observe the Fluid as it runs into the container, watching for air bubbles and other signs of contamination in the Fluid. When clear Fluid exits the hose, close the Bleeder Valve.

Repeat this Bleeding process for all four wheels in the proper sequence.

Close the Supply Valve in the Pressure Bleeder Hose, remove the Bleeding equipment, and check the Brake System for leaks.

Pressure Bleeder with Hose and Master Cylinder Adapter

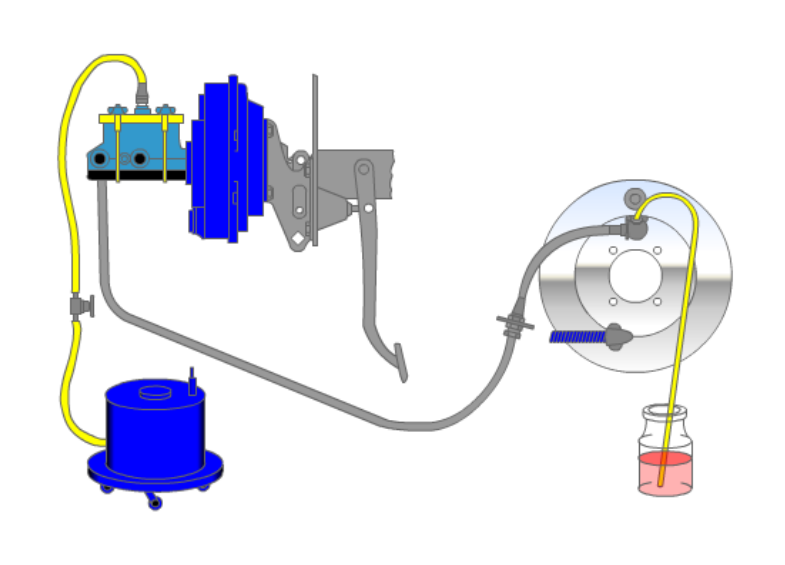

Lower the vehicle, remove the Metering Valve Tool, if used, and top the Fluid Level in the Master Cylinder Reservoir, if necessary.

Test the Brakes to make sure the Pedal is firm before driving the vehicle. If the Pedal feels spongy or soft, repeat the entire process.

Air Bubbles Forced out of the Brake System

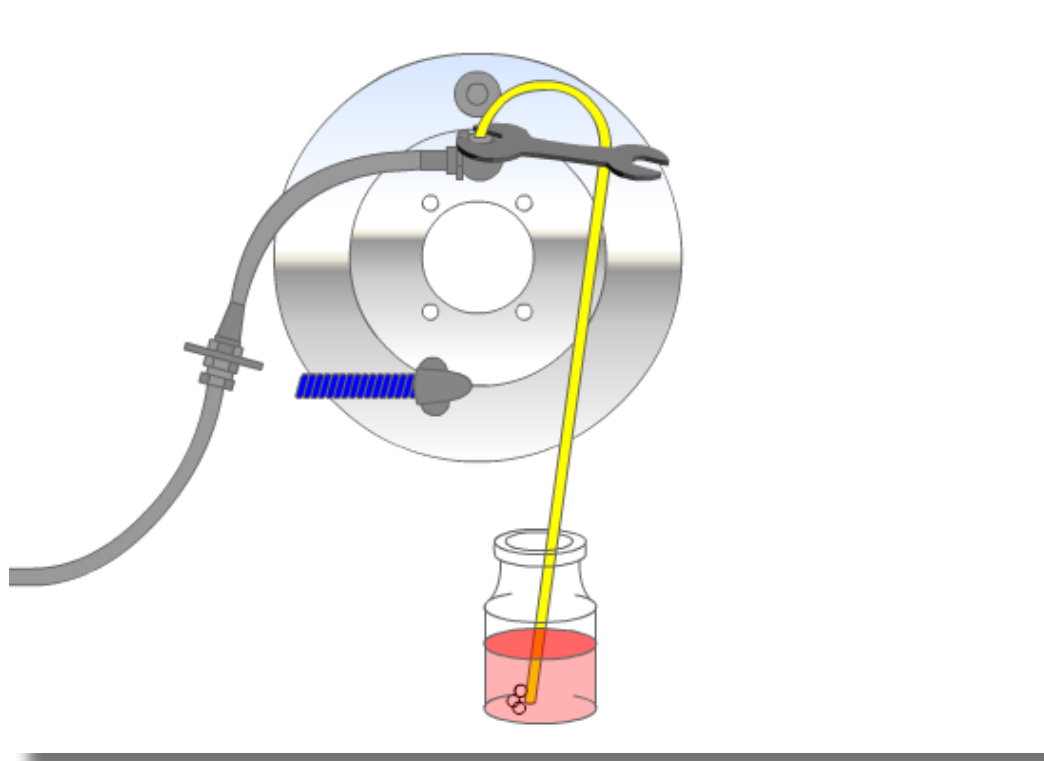

LINES AND HOSES

↻ Brake Lines and Hoses

Brake lines and hoses are responsible for transferring Fluid Pressure from the Master Cylinder to the Brake Calipers and Wheel Cylinders. On some vehicles, that pressure can exceed 1000 psi. Additionally, the Brake hoses (the shorter rubber-covered sections that connect at the Wheels) must also handle this duty while maintaining a high degree of flexibility. Because of the pressures involved, only double-walled steel Brake tubing is approved for use in Brake lines.

CAUTION: Never use copper tubing as a replacement! It cannot withstand the High Pressure or the vibration to which Brake lines are exposed. Fluid leakage and/or System Failure will result.

BRAKE LINES

When replacing a Brake line, it is advisable to purchase a pre-formed OEM replacement, as they are of the correct length, bend, and strength to handle the System demands. It can also be more cost-effective since bending and flaring brake lines can be quite time consuming. In addition to OEM replacements, aftermarket lines are also available in various lengths and diameters, often pre-flared and with flare nuts installed.

Bulk Brake line is also available which can be cut to length and flared as needed. Keep in mind, however, that this is a job only for those with the requisite tools and skills. Additionally, care must always be exercised when bending any Brake line so as to not kink and weaken the line.

Brake Tubing with Flared Ends and Flare Nuts Installed

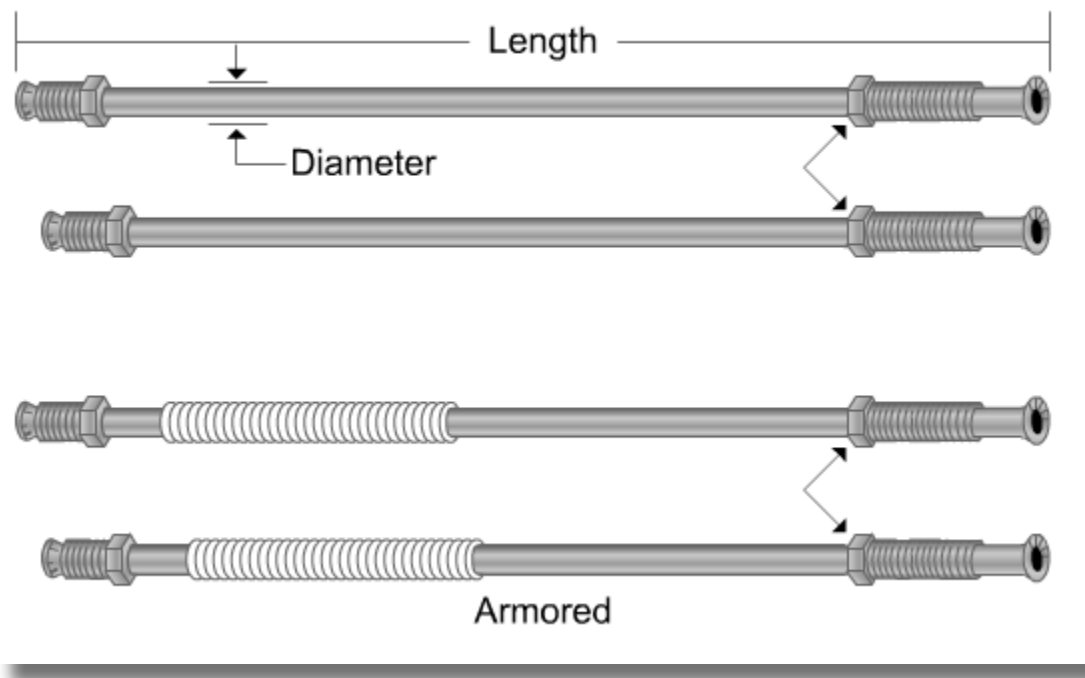

Cars and Light Trucks tend to utilize one of two types of Brake line connection flarings, and each requires its own special tools and flare nuts.

They are:

- ISO (International Standards Organization) Flare
- Double Flare

Some fittings use a hollow bolt to carry Brake Fluid. These fittings are called banjo fittings and banjo bolts.

Always use only replacement fittings that are designed for the Brake System being serviced.

CAUTION: Never cut a brake line in order to repair it. Always replace - **never repair** - brake lines.

ISO and Inverted Double Flares are Distinguishable by the Shape of the Flare

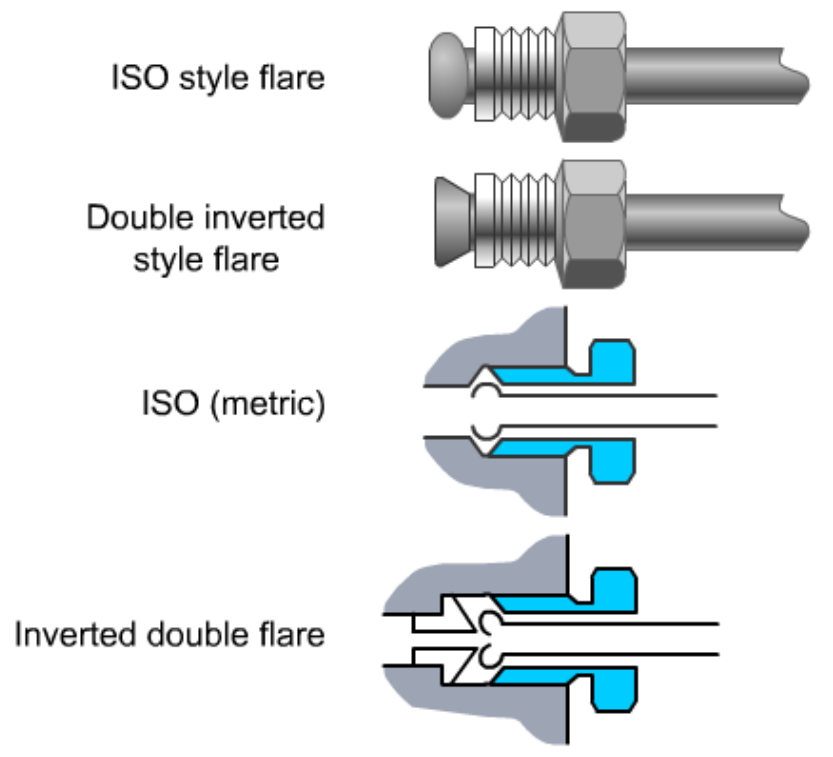

BRAKE HOSES

Automotive brake hoses are designed to distribute high pressure brake fluid to the wheel brakes. They must also allow for the vertical movement of the suspension and the side-to-side motion of the front wheels as the driver steers the vehicle. These forces are substantial and can weaken the hoses over time.

When performing Brake Service, always remember to:

- Inspect the hoses for damage, kinks or ballooning
- Inspect hoses for proper routing
- Never hang a Caliper from a rubber Brake Hose
- Replace the copper sealing washers when replacing Brake Hoses

Defective or damaged hoses can balloon or swell, which will store Brake Fluid Pressure and cause the vehicle to pull during Braking or give a low Pedal concern.

A blocked, restricted, or kinked Brake Hose can also cause the vehicle to pull during Braking since it will limit Fluid Pressure to its Brake. In this case, the pull will be to the opposite direction of the problem component. That means that a Left Front hose that is blocked, restricted, or kinked would cause a pull to the Right and a Right Front hose failure would cause a pull to the Left during Braking.

Brake Hoses and Failure Modes

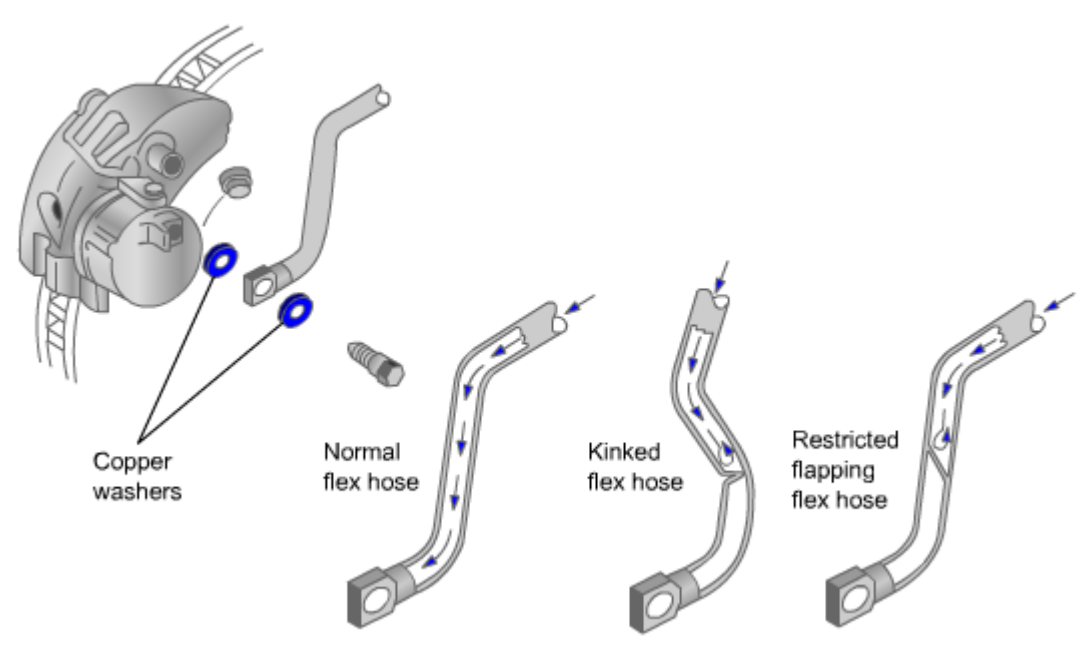

INSPECTING AND REPLACING BRAKE LINES AND HOSES

Inspect all metal Brake lines for cracks, dents, corrosion, and leakage around fittings. Replace any damaged lines.

Corrosion can “freeze” the flare nut to the Brake line. If the nut cannot easily be freed, cut the line, remove the frozen fitting, and replace the entire line.

CAUTION: Always check and refill the Master Cylinder after testing or servicing Hydraulic System components.

CAUTION: Always make sure the Hydraulic System is free of air after testing or servicing Hydraulic System components.

CAUTION: Do not attempt to patch or add sections to the Brake lines. If a line is damaged, replace the entire line.

Note: When replacing Brake lines, be sure to use two wrenches on the flare nuts to avoid damaging the fittings.

Inspect all Brake Hoses for deterioration, chafing, swelling, cracking, cuts, or twisting.

CAUTION: Always replace damaged or worn Brake Hoses. Do not attempt to repair them.

- Replace Hoses that are oil soaked, soft, spongy, leaking, or have deeply cracked covers.
- If the Brake on one Wheel drags (does not release), it may be necessary to replace the Brake hose on that Wheel. Sometimes an internal failure in a Brake Hose can cause the Brake to drag.
- Brake Hoses are usually fastened to the vehicle chassis with a sheet metal clip to prevent chafing. Disconnect the flare nut from the hose before removing the sheet metal clip.
- Make sure the replacement hoses are sufficiently long. Suspension movement or steering action should not stretch the hoses.

UNIT 3 DRUM BRAKES

The following topics are addressed in this unit:

INTRODUCTION TO DRUM BRAKES

- Introduction
- Brake Drum
- Brake Shoes
- Wheel Cylinder
- Backing Plate
- Duo-Servo Brake Operation
- Self-Adjusters
- Leading-Trailing Brake Operation

SERVICING DRUM BRAKES

- Disassembly
- Inspection and Diagnosis
- Wheel Cylinders
- Reassembly
- Machine Brake Drums
- Brake Service Tips
- Wheel Assembly

CHAPTER 1: INTRODUCTION TO DRUM BRAKES

INTRODUCTION

➔ Drum Brakes

A Drum Brake unit consists of two Brake Shoes mounted on a stationary Backing Plate. When the Brake Pedal is pressed, a Hydraulically activated Wheel Cylinder pushes the Shoes out to contact a rotating Drum which creates Friction and slows the vehicle. As the Pedal is released, Return Springs retract the Shoes to their original position.

Note: Late model vehicles that use Drum Brakes will have them only on the Rear Wheels.

The two most common types of Drum Brakes are **Duo-Servo** and **Leading-Trailing**.

Duo-Servo Brake Assembly



We'll deal with the components, structure, and operation of Duo-Servo Brakes here and Leading-Trailing Brakes in a later section.

DUO-SERVO BRAKES

Duo-Servo Drum Brakes consist of the following components:

- Brake Drum
- One Primary Shoe and one Secondary Shoe with Friction Linings
- Wheel Cylinder
- Anchor(s)
- Backing Plate
- Adjusting Screw
- Return Springs, Hold Down Springs, Connecting Springs
- Adjusting Linkages and Springs

Duo-Servo Brake Component Highlights

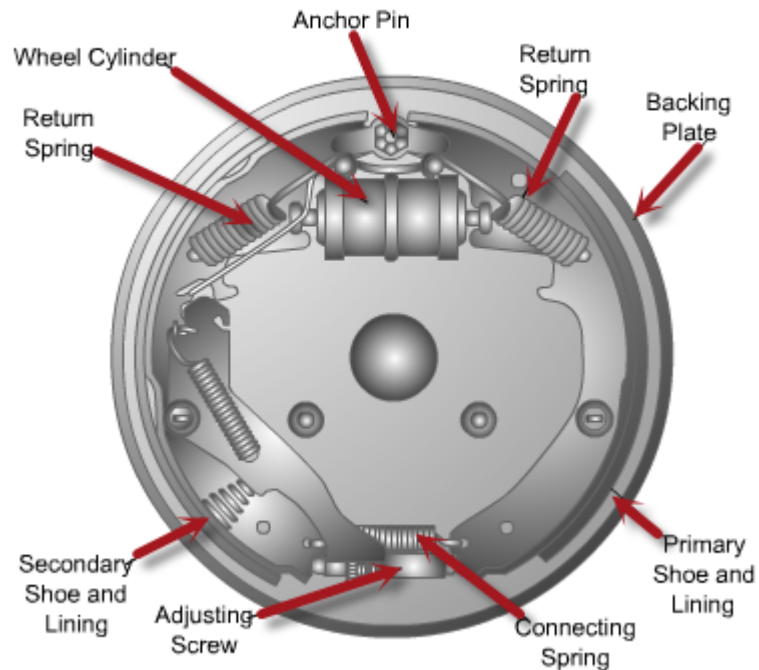

BRAKE DRUM

A Brake Drum provides a Friction surface, usually iron, to which the Brake Shoes are applied. When Brake Shoes are pressed against a Drum, they convert the Kinetic Energy of the moving vehicle into Heat Energy, and then dissipate that heat.

All Brake Drums rotate with the Wheels and in some systems the Drums actually contain the Wheel Hub and Wheel Bearings. If a Drum includes the Hub, that Drum will provide the mounting hardware for the Wheel and Tire Assembly. If the Drum and Hub are separate, the Hub will provide the mounting hardware for both the Drum and the Wheel/Tire Assembly.

Brake Drums must be perfectly round and concentric with the spindle or axle, otherwise Brake Pedal pulsations can occur.

Deep grooving in a Drum Friction surface can prevent new Shoes from conforming to the Drum. Also, Brake Drums with deep grooves in their surface can be difficult to remove.

Brake Drums have a 'Maximum Diameter' dimension that is either cast into the Drum or available in the applicable service information. All Drums must be checked to insure that they conform to this limit before being installed/reinstalled on a vehicle

BRAKE SHOES

When a driver presses a Brake Pedal, Hydraulic Pressure in a Wheel Cylinder forces the Shoes against a rotating Brake Drum, thus producing Friction that transforms Kinetic Energy into Heat Energy.

Brake Shoes are arc-shaped, to conform to the Brake Drum surface, and have a layer of Friction material (Brake Lining) that is either bonded (glued) or riveted to the Brake Shoes.

WHEEL CYLINDER

A **Wheel Cylinder** consists of the following parts:

- Cylinder Body
- Two Pistons
- Two Lip Seal Piston Cups
- Expander Spring Assembly
- Two Dust Boots
- Two Actuating Pins (some models)
- Bleeder Valve

When a driver applies the Brake Pedal, Hydraulic Pressure from the Master Cylinder moves to the Wheel Cylinder. In the Wheel Cylinder, Hydraulic Pressure causes the Cylinder Cups (seals) to push the Pistons outward, which forces the Brake Shoes against the Drum.

As the driver releases the Brake Pedal, the Hydraulic Pressure is removed. The Brake Shoe Return Springs then pull the Shoes back against their Anchor(s) and retract the Wheel Cylinder Pistons.

Typical Wheel Cylinder



Wheel Cylinder Disassembled View

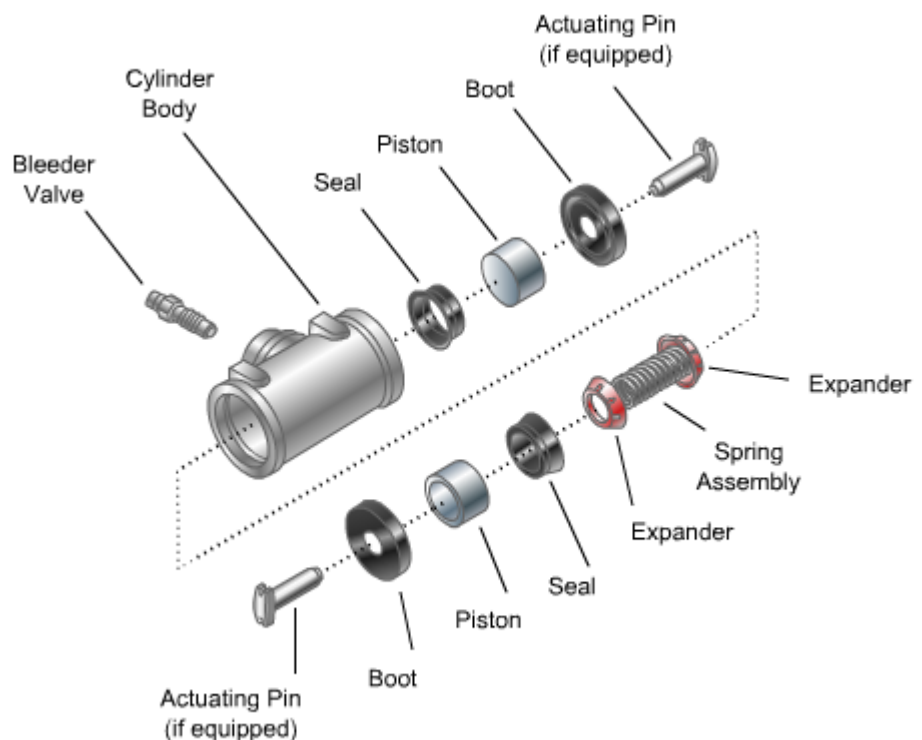

Wheel Cylinders connect to the Master Cylinder through a series of steel lines and hoses.

The Wheel Cylinders are always fastened to the Brake Backing Plate.

Each Wheel Cylinder has a Bleeder Valve for removing air from the Cylinder and Lines.

BACKING PLATE

The **Backing Plate** is a stamped steel disc that connects to the spindle, or axle housing, but does not rotate.

Backing Plates provide the foundation for Drum Brake systems. The Anchor(s), Wheel Cylinders, Return Springs, and some of the Adjuster Linkages, are fastened to the Backing Plate. They also have built-in pads on which the Brake Shoes can slide.

Certain springs and pins, known as Shoe Hold-Down devices, are also used to hold Brake Shoes to the Backing Plate while still allowing the Shoes to slide outward to the Drum during Brake application.

Brake Shoe Return Springs pull the Brake Shoes away from the Drum, and return them to their rest position. In some systems, the Return Springs also help activate the Automatic Adjusters.

BRAKE ANCHORS

A **Brake Anchor** is a round piece of steel that either connects to the Backing Plate, or threads into the spindle, through a hole in the Backing Plate. Brake Shoes rest against the Anchor(s), when released, and the Return Springs are attached to them.

Anchors bear all the Force that the Brake Shoe(s) apply to the Drum and therefore must be very solid.

Most Duo-Servo systems use one Anchor per Wheel, while other systems use two Anchors per Wheel, one for each Shoe.

DUO-SERVO BRAKE OPERATION

When Duo-Servo Brakes are in the released position, an Adjuster Return Spring(s) holds one end of the shoes against an Adjuster Screw while the other end of the shoes are held against an Anchor pin by Return Springs.

Backing Plate



As the Brake Pedal is pressed, the following occurs:

- Hydraulic Pressure from the Master Cylinder to the Wheel Cylinder forces both Wheel Cylinder Pistons outward to press the shoes against the Drum.
- As the Brake Shoes contact the rotating Drum, Frictional Force causes both shoes to rotate slightly (clockwise on the right side of the vehicle and counter-clockwise on the left side). This action causes the Secondary Shoe (the one toward the rear of the vehicle) to jam against the anchor pin.
- The rotating action of the Primary Brake Shoe (the front one) causes the Secondary Shoe to wedge into the Drum with a Force that is greater than just the Hydraulic Pressure would cause.
- Because of this 'wedging' action, both shoes must be pulled away from the Drum (by the Return Springs) when the Brakes are released. Additionally, there are other springs that hold the Brake Shoes in place and return the Adjuster Arm after it actuates.
- As a result of this design, the Secondary Shoes must perform more of the braking than the Primary Shoes. Therefore, the Secondary Shoes usually wear more and are typically longer than the Primary Shoes.

As a general rule-of-thumb, the heavier a Drum-Brake-equipped vehicle is, the more likely it is to have a Duo-Servo Brake system.

Applying Drum Brakes

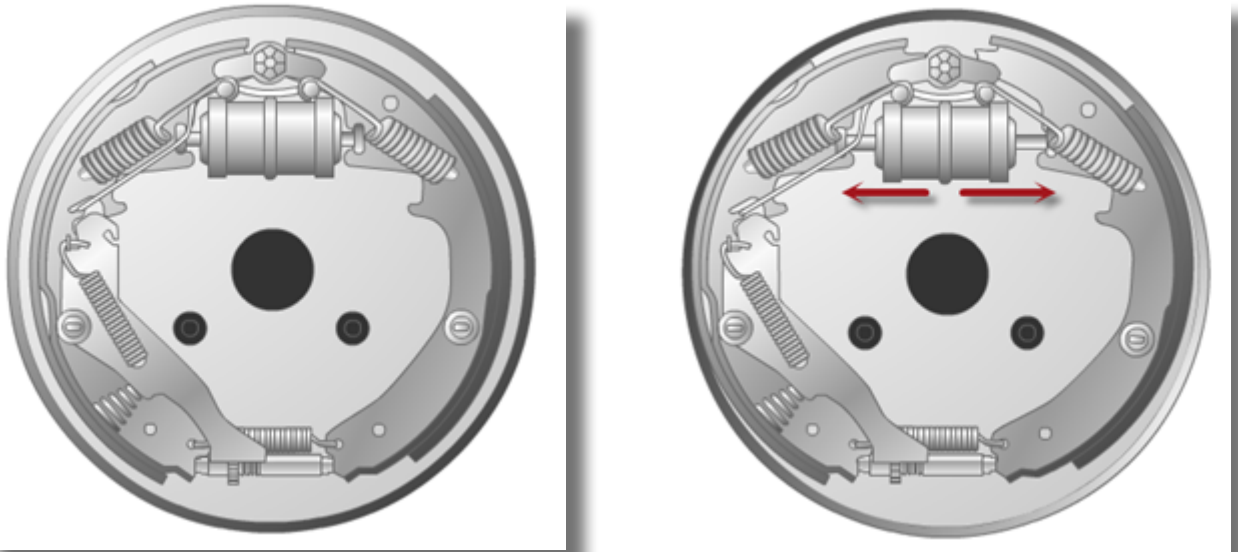

SELF-ADJUSTERS

Drum Brake systems have a self-adjust capability that compensates for wear on the Brake Shoes. A Self-Adjuster mechanism consists of a series of links, springs, retainers and a Star Wheel (screw) Adjuster. The rotational action of the Brake Shoes activates the Self-Adjuster Linkage when the Brakes are applied and the vehicle is moving in reverse.

Brake Adjuster as the Brakes are applied in Reverse.

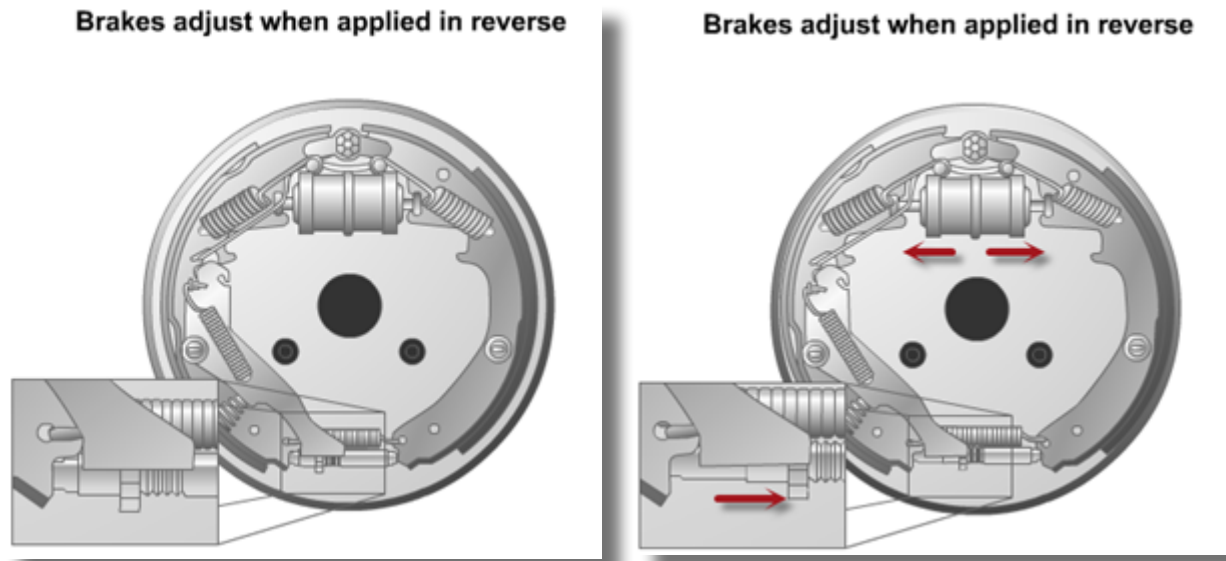

As the clearance between the Shoe and Drum increases, the distance that the Shoe moves also increases. When a predetermined amount of Shoe movement occurs, the linkage moves the Adjuster's Star Wheel, thus adjusting the clearance.

Note: In Duo-Servo Brakes, the Adjuster is a threaded link that bridges the end of the Brake Shoe located opposite the Anchor.

Note: Many Duo-Servo Brake Adjusters are threaded in opposite directions and can be used only on the side of the vehicle where they were originally installed. As such, they are not interchangeable from side to side.

The three types of automatic adjuster linkages are lever, cable, and link.

LEADING-TRAILING

➤ Leading-Trailing Brake Operation

There are three major differences between Duo-Servo and Leading-Trailing Drum Brakes:

- Leading-Trailing systems have the Anchor Pin mounted at the bottom of the Backing Plate rather than at the top.
- Neither Shoe pushes against the other in Leading-Trailing Brakes, as in Duo-Servo systems.
- Leading-Trailing Drum Brakes are automatically adjusted when the Parking Brake is applied and released.

The operation of a Leading-Trailing Brake system is much simpler than a Duo-Servo system. When the Brake Pedal is pressed a Wheel Cylinder pushes equally on each Brake Shoe, which forces the tops of the Shoes outward toward the Drum, while also pivoting on the bottom anchor. Drum Friction pulls the Leading (forward) Shoe into tighter contact with the Drum and aids the Hydraulic Force of the Wheel Cylinder. This action provides most of the Braking Force. The Trailing Shoe is not self-energizing, as in a Duo-Servo System, but does provide some Braking Force due to the action of the Wheel Cylinder. In reverse, the opposite action takes place. Leading-Trailing Brake systems have identical Leading and Trailing Brake Linings.

Leading-Trailing Brake Component Highlights

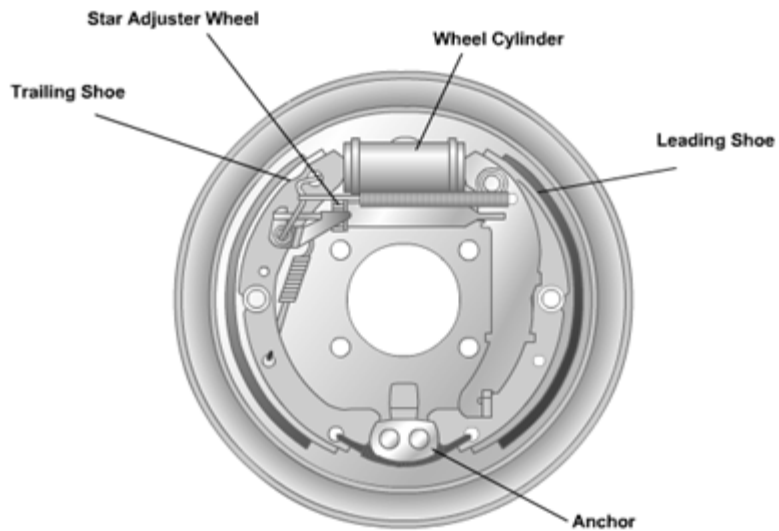

As a general rule-of-thumb, the lighter a Drum-Brake-equipped vehicle is, the more likely it is to have a Leading-Trailing Brake system.

CHAPTER 2: SERVICING DRUM BRAKES

DISASSEMBLY

DISASSEMBLING A DRUM BRAKE UNIT

Use proper lifting equipment, and safe procedure, to raise the vehicle.

CAUTION: When lifting a vehicle, always use proper lifting equipment and observe all safety precautions.

Use a brake cleaning device, such as a Brake Washer (air or liquid) to clean all of the Brake Drum components being serviced. Refer to 'Removing Brake Dust' in Unit One if necessary.

Brake Washer

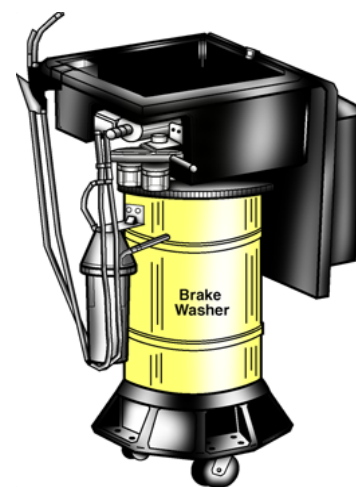

CAUTION: Do not breathe the dust that comes off of the Brakes or allow it to escape into the air. If the proper equipment for working with Brake Systems is unavailable, or in poor working order, do not perform Brake work.

With a brake cleaner connected to the Brake Assembly, remove the Brake Drum and clean the Drum and Brake Assembly components.

Brake Drum Components



Brake Drum



If this is the first time the Drum has been removed, it may be necessary to remove the 'washer clips' that are on the Wheel Studs next to the Drum itself. These clips are used in the factory to prevent Drums from falling off during assembly and do not need to be reinstalled. Cutting them off with Side Cutters is typically the easiest way to remove them

Note: In some cases, if the Brake Drums are badly grooved by the Brake Shoes or rivets, Brake Drum removal may be difficult. If this occurs, the Brake Adjusters may need to be loosened before the Drums can be removed.

Backing off the Brake Adjuster

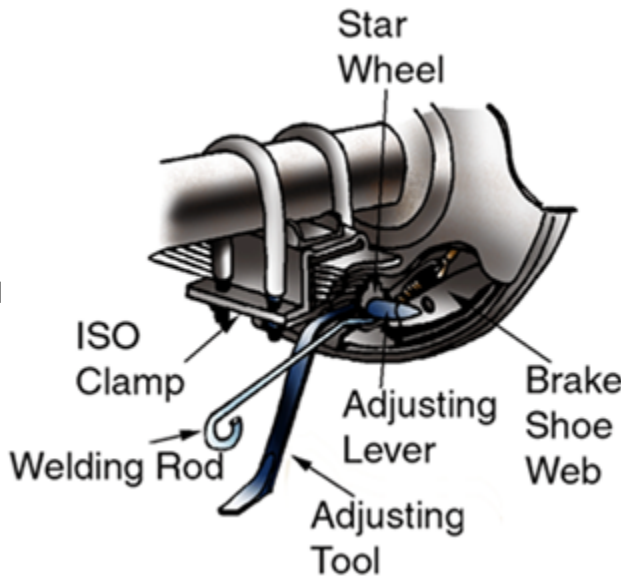

To back off the Brake Adjuster, use a Brake spoon to rotate the Star Wheel, against the Adjuster Lever. It may be necessary to push the lever away from the Star Wheel using a welding rod, screwdriver, etc. before the Star Wheel can be turned in that direction.

An opening in the backing plate, or Brake Drum, will provide access to the Adjuster. This opening may be sealed with a rubber plug(s). If adjuster access is through the Brake Drum, the opening may be a knockout which will have to be removed with a punch. In either case, be sure to close the opening with the proper rubber plug when finished.

Note: It may be necessary to remove the brake cleaner equipment to make this adjustment. If so, be sure to reinstall it before removing the Brake Drum.

After removing the Brake Drum, use the Brake cleaner to remove the dust from all of the Brake Assembly components, including the Backing Plate.

After all of the parts are clean, remove the Brake cleaning equipment from the wheel.

Note: Only one Drum Brake Assembly should be taken apart at a time to prevent confusing parts from one side with those from the other side. The assembled Brake components can also be used as a guide for reassembly.

Using a Brake Spring Tool, remove the Brake Shoe return springs from the anchor.

Removing Return Springs



Using the Hold-Down Spring Tool, remove the Brake Shoe hold-down latches on both Shoes.

Removing Hold-Down Springs

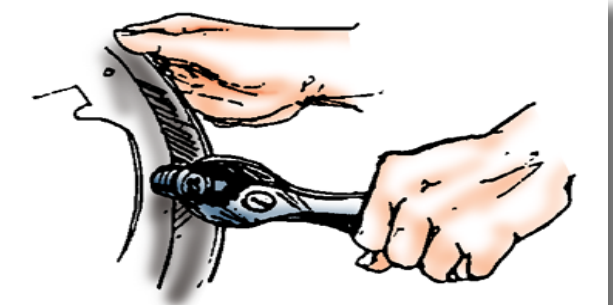

Continue the disassembly as follows:

Disconnect the Adjuster Linkage from the anchor.

Removing Shoes from the Anchor

Grasp both shoes at their tops and pull them away from the anchor.

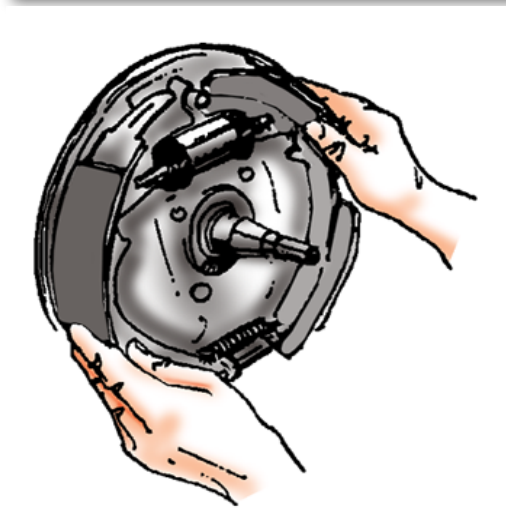

Note: When pulling the Rear-Wheel Brake Shoes away from their anchors, separate the Parking Brake Lever from the Secondary Shoe and leave the lever hanging on the cable while servicing the other components.

INSPECTION AND DIAGNOSIS

VISUAL INSPECTION

Note: A thorough visual inspection can only be done with the Brake Drum(s) removed, and is the only reliable method for determining the condition of Brake components.

Begin by checking the Fluid Level in the Master Cylinder and inspecting the Hydraulic System.

Note: If the Wheel Bearing is disassembled, clean and repack it before reassembling the Hub.

Drum Brake Components

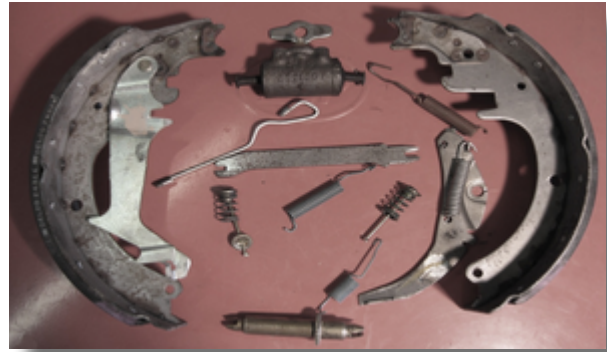

INSPECT THE BRAKES

1. Carefully inspect the Brake Assembly and note any indication of Fluid leaks. Identify the source of any leaks.

Note: If the Rear Brake on a Rear-Wheel-Drive vehicle is contaminated with a heavy lubricant, the axle seals are likely leaking. Replace the axle seals as well as the Brake Shoes.

Note: Do not use engine solvents on Brake parts as they may contaminate the components and cause premature Brake failure. Use only solvents made specifically for Brakes.

2. Inspect the Brake Linings.

Check the thickness of the Brake Linings, remembering that some linings are riveted to the Shoes while others are bonded:

- Rivet heads should be at least 1/16 inch below the Lining Surface.
- A lining that is bonded to a shoe should be at least as thick as the shoe itself.
- Replace any shoes that do not clearly meet thickness standards.

Note: All vehicles should have periodic Brake checks, and annual checks are recommended for vehicles with more than 40,000 miles. Brakes should be checked immediately if there are any unusual sounds during braking or if the Brakes fade, pull, vibrate, or lose effectiveness.

Check the Brake Linings for cracks, loose rivets, missing or damaged areas, or any other problems.

3. Inspect the Backing Plate for cracks or distortions and replace it if any are found.

Make sure the Backing Plate is securely mounted and check for any grooves or nicks on the Shoe Contact Pads. If any of these locations are grooved, file the areas or replace the Backing Plate.

4. Inspect the Brake Shoe Return Springs for cracks or distortion, and insure that they are connected at both ends.

5. Make sure the Hold-Down Springs are not distorted and that the pins are not bent.

Return Spring



Hold Down Springs

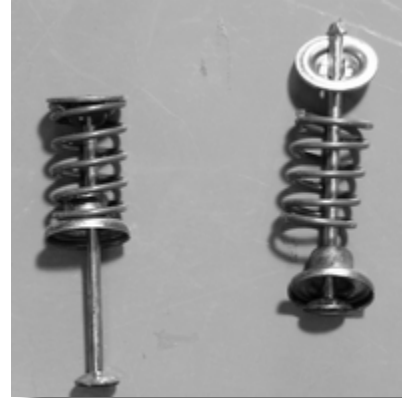

6. Brake inspection points.

Drum Brake Components

Drum Brake Components

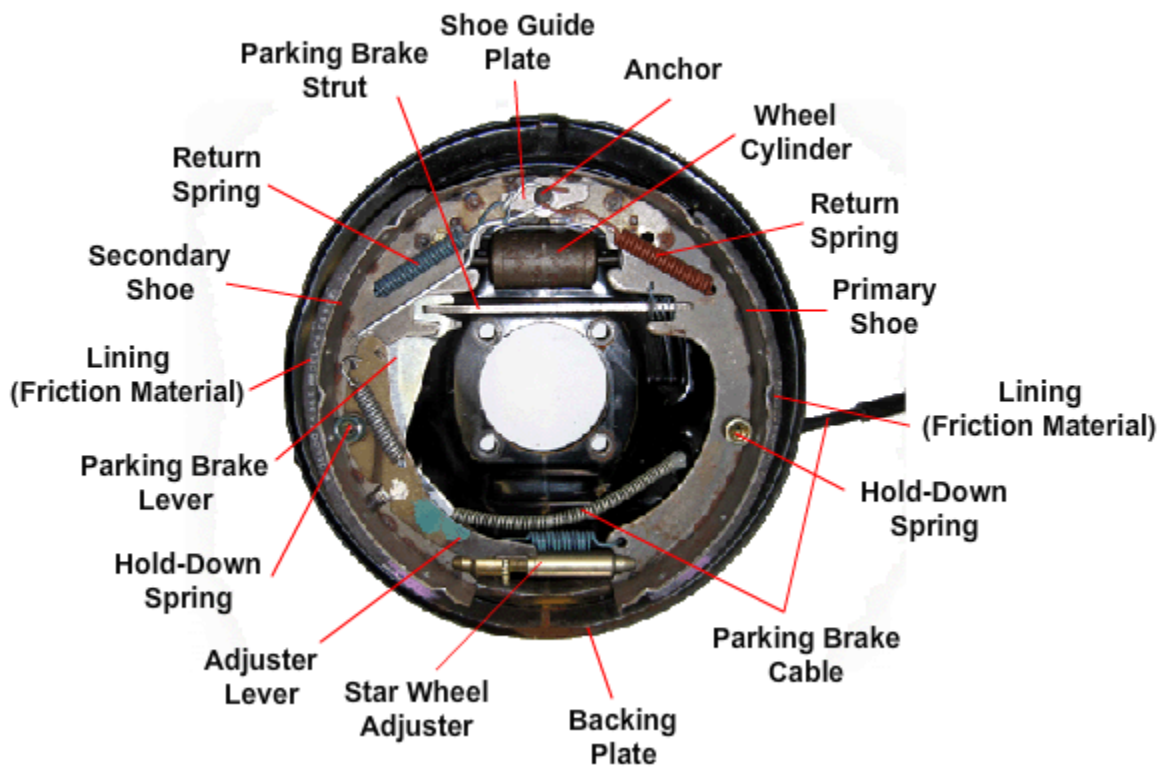

Make sure that the Adjuster Lever is not rounded at the point where it contacts the Star Wheel, that the Adjuster Wheel is not missing any teeth, and that the Adjuster threads turn freely.

Also make sure that the Adjuster Lever is positioned so as to operate properly.

Remove, disassemble, and clean the Self-Adjuster if it is dirty or hard to rotate. Simply unscrew the link and clean the threads with a wire brush. On Duo-Servo Brakes, the Adjuster can be removed and cleaned without disassembling the entire Brake. A large screwdriver, or similar tool, can be used to pry apart the Adjuster end of the Shoes enough to allow removal of the Adjuster.

Remove the socket, taking care to not lose the Thrust Washer located between the Socket and Adjusting Screw.

Lightly lubricate the threads of the Adjuster Screw and Socket with an approved lubricant making sure that the Thrust Washer is in place.

Reassemble the Adjuster and screw the Adjuster Link down to its shortest length.

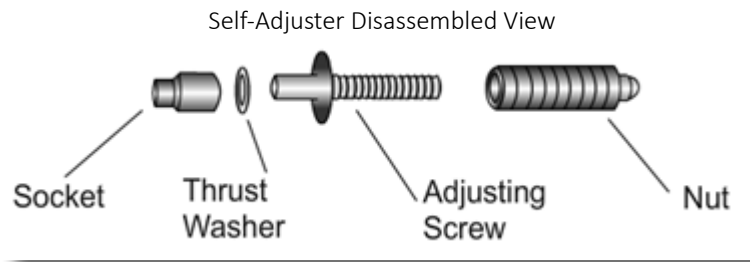

If the Adjuster was removed without disassembly of the rest of the Brakes, it can now be reinserted. Simply spread the Brake Shoes sufficiently to replace the Adjuster while ensuring that the Adjuster Lever is properly positioned to turn the Star Wheel.

7. Inspect the Anchor.

Make sure the Anchor is firmly attached and that the Return Springs hold both shoes firmly against the anchor.

If either shoe is not held against the Anchor, determine why and correct.

If the Parking Brake is applying pressure to the Rear-Wheel Brake Shoes, remove the pressure by turning the Parking Brake Cable Adjustment.

Note: When the Parking Brake is released, the Parking Brake Cable should never move either shoe off the anchor.

8. Look for wetness around the Wheel Cylinder Dust Boots or any other signs of leaks.

9. Inspect the Brake Drum.

Inspect the general condition of the Drum and note if the Drum is belled, barreled, or grooved. Also note if the Drum is warped, distorted, cracked, or has blue spots.

Find the Drum's Discard Diameter. As a Drum wears, its diameter increases and the Discard Diameter is the dimension where a Drum can no longer be reused. Discard Diameters will either be cast into the Drum itself or in the vehicle's service information.

Using a Drum Micrometer, measure the Drum's Diameter at several points around its circumference.

If all the micrometer measurements vary by less than .010 in (.25mm), and none are greater than the Discard Diameter, the Drum is concentric and can be reused.

If a Drum is not concentric (micrometer measurements vary by more than .010 in.), it can be machined (turned) and returned to 'roundness' as long as its final diameter remains below the Discard Diameter. If a Drum ever exceeds its Discard Diameter, it must not be reused.

Check the Drum for grooves and estimate their depth. Determine if machining the grooves will cause the Drum to exceed its Discard Diameter.

Note: A groove increases a Drum's Diameter by twice the depth of the groove.

Note: Minor grooving is acceptable if the Drum does not exceed its Discard Diameter.

Note: On some vehicles, the Wheel Hub is an integral part of the Drum. When inspecting the Wheel Bearings on these vehicles, make sure that the Bearing cups (races) are in good condition and are firmly pressed into the Hub.

If the Wheel Hub was not removed during Drum removal, remove and service the Wheel Bearings, if possible.

Note: Usually, the Rear Hub Bearings in Front-Wheel-Drive vehicles cannot be serviced. If the bearings are excessively worn or damaged, replace the entire Hub Assembly.

Brake Drum



WHEEL CYLINDER

↪ Disassembling and Inspecting Wheel Cylinders

WHEEL CYLINDER SERVICE

Any time Brake Shoes are replaced, the Wheel Cylinders should be inspected and replaced if necessary.

Wheel Cylinders are not typically disassembled for inspection unless there is a specific reason to do so. Usually, if a Wheel Cylinder is working, not leaking, and the exposed rubber parts are not deteriorated, it is considered to be serviceable, or reusable. However, if there is evidence of leakage or deterioration, then it will be necessary to remove the Wheel Cylinder and replace it.

When servicing Wheel Cylinders, remember that if the shoes are replaced, the Wheel Cylinder pistons will run deeper into the cylinders. New shoes also cause the Wheel Cylinder Cups to run in a different area of the cylinder.

Note: Before removing any Wheel Cylinder that is to be reused, it is a good idea to first loosen the Bleeder Valve. That will make it easier to work with later.

Removing a Wheel Cylinder:

- Disconnect the Brake Line or Hose from the Wheel Cylinder. The use of 'Crows Foot', 'Flare Nut', or 'Line' wrenches will make this task easier while preventing damage to the Flare Nut or Hydraulic Line.
- Remove the bolts, or snap rings, that hold the Wheel Cylinders to the Backing Plate.
- Remove and clean out the Bleeder Valve.

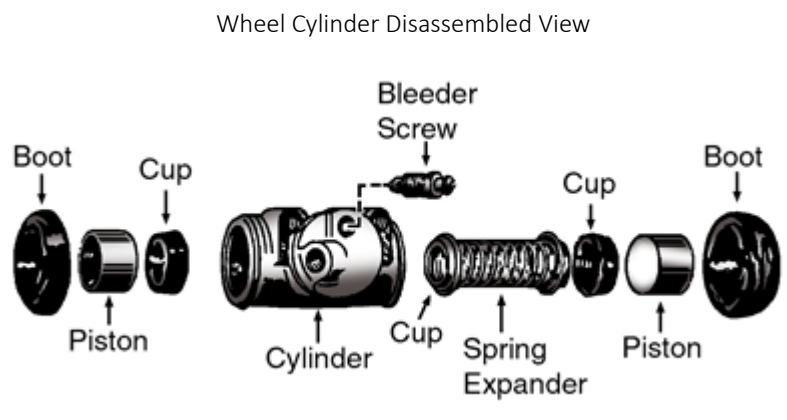

Note: Although it is possible to rebuild Wheel Cylinders, it is typically not cost effective to do so.

- Reinstalling a Wheel Cylinder:
- Install the Bleeder Valve, making sure that it is clean and clear.
- Remount the Wheel Cylinder to the Backing Plate using the previously removed bolts or snap rings
- Reinstall the Brake line or Hose according to the repair manual procedures.
- Reinstall the Wheel Cylinder pins, if equipped.

REASSEMBLY

➤ Installing and Adjusting Drum Brake Components

CAUTION: Always performance test Brake Systems after any repairs.

INSTALL THE BRAKE SHOES

Carefully inspect the Shoe Contact Pads on the Backing Plate for grooves and other signs of wear. File the Shoe Contact Pads flat or replace the Backing Plate as necessary.

Next, lightly lubricate the Backing Plate Shoe Pad Areas with a High Temperature lubricant.

Clean and lubricate all Brake hardware. Check the springs for corrosion or distortion and replace any components of questionable quality.

If not already done, clean and lubricate the Adjuster according to the procedure in the previous section.

Note: If installing new Brake Shoes, carefully compare the new ones with the old ones, including the Shoes' spring holes and arc diameter.

Examine the new Brake Shoes to determine if there is a difference between the lengths of the Shoes' Linings. This is important since most Duo-Servo Brakes use two different Shoes on each wheel. If the Shoe Linings have different lengths, the Brake with the longer lining should be installed in the secondary, or rearward, position.

Assemble the two Shoes on one side by connecting the Adjuster end of the Shoe with the spring and the Adjuster. The Star Wheel end of the Adjuster should be located toward the rear of the vehicle next to the Secondary Shoe.

Spread the tops of the Shoes and slip them over the Anchor, ensuring that they both properly engage the Wheel Cylinder.

Note: On some vehicles, it will be necessary to connect the Adjuster Linkage at this time.

Note: On Rear-Wheel Brakes, install the Parking Brake Lever next.

Preparing the Brake Shoe Pad Areas

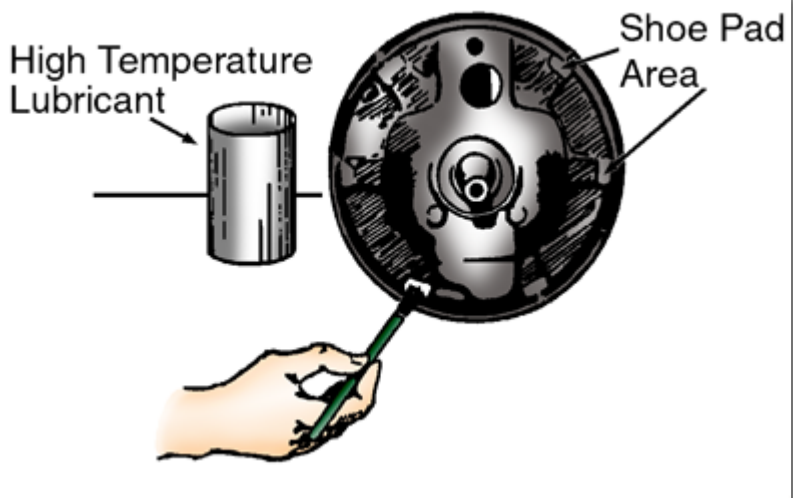

Installing the Brake Shoes

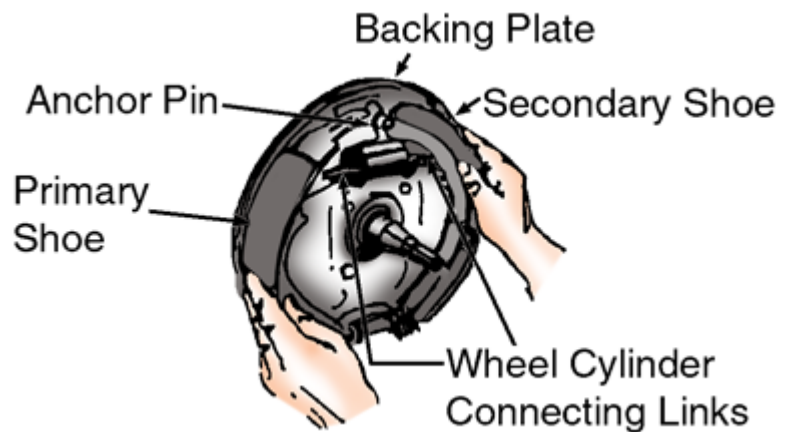

INSTALLING THE HOLD-DOWN SPRINGS

Using a Brake Spring Tool, install the Brake Shoe Return Springs. Examine the shoes to make sure they both contact the Anchor and that the Automatic Adjuster operates properly.

ADJUST THE BRAKE SHOES

Using a Brake Shoe Gauge, adjust its 'outside gauge' to fit the Drum and tighten its knob to lock the setting.

Using a Brake Shoe Gauge to Pre-Set the Brake Shoe Adjustment.

Using the 'inside gauge', adjust the Adjuster Star Wheel outward until the center of the Brake Shoes touches the gauge. This dimension setting will give a good 'starting point' for proper Brake Shoe adjustment. The Brake Shoes will still need a final adjustment, using a Brake Spoon, after the wheels are installed.

EXAMINE THE PARKING BRAKE LINKAGES

Make sure the Parking Brake is disengaged and the cables are not binding in their housings.

Ensure that the Brake Shoes are resting against the Anchor. If the Parking Brake prevents a Brake Shoe from contacting the Anchor, adjust the length of the Parking Brake Cable.

INSTALL THE DRUM

If the Hub is part of the Drum, be sure that the Wheel Bearing has been serviced.

Install and torque the wheel to the proper specification.

If installing the Drum Brakes on the Rear Wheels, adjust the Parking Brake at this time, following the manufacturer's procedure.

Installing the Brake Shoes

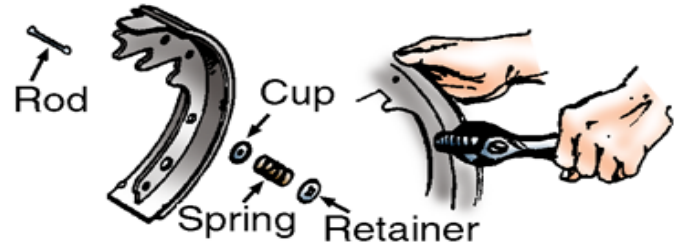

Shoe Gauge



MACHINE DRUMS

➔ Machine Brake Drums

BRAKE DRUM INSPECTION

Any time Brake service is performed, all Brake Drums should be inspected for the following:

- Excessive wear or scoring
- Hot spots or bluing
- Out-of-round
- Distortion
- Cracks

Any Brake Drum that is cracked must be replaced. Those that have hot spots, distortion, or are out-of-round can cause braking problems such as pulling, vibration, chatter, noise and pulsation. Sometimes these Drums can be refinished and reused; other times they must be replaced. Drums that exhibit minor scoring but have no other problems can sometimes be reused without refinishing, however, it is critical that the diameter of a Drum be measured to determine if it can be safely refinished and reused.

Brake Lathe



MEASURING BRAKE DRUMS

When measuring brake drums to determine if they can be reused, there are two specifications that must be understood.

- Maximum refinish diameter
- Discard diameter

Maximum refinish diameter is fairly straightforward and is the maximum diameter to which a drum can be turned and still be reinstalled on a vehicle. The Maximum Refinish Diameter specification lets the technician know that there is enough material remaining on the drum to be used safely and without an increase in the potential for failure. Maximum Refinish Diameters vary among drums. The actual specifications are available in the service manual for the vehicle being repaired.

Brake Drum Discard Diameter

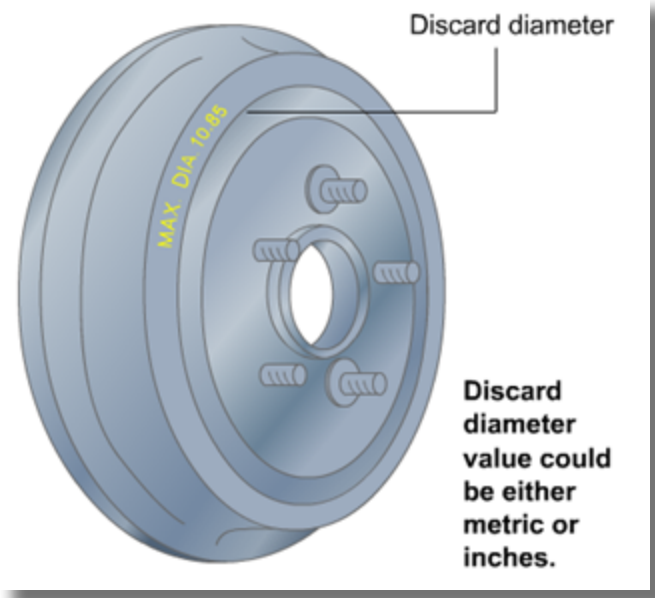

Discard diameter, as seen before, is the diameter to which a drum can be reused if not refinished. If a drum exceeds the Maximum Discard Diameter, either from refinishing or through normal wear, it must be discarded. The Maximum Discard Specification is usually stamped or cast into the drum surface. The difference between the Maximum Refinish Specification and the Maximum Discard Specification is the amount that must be allowed for the drum to wear after refinishing.

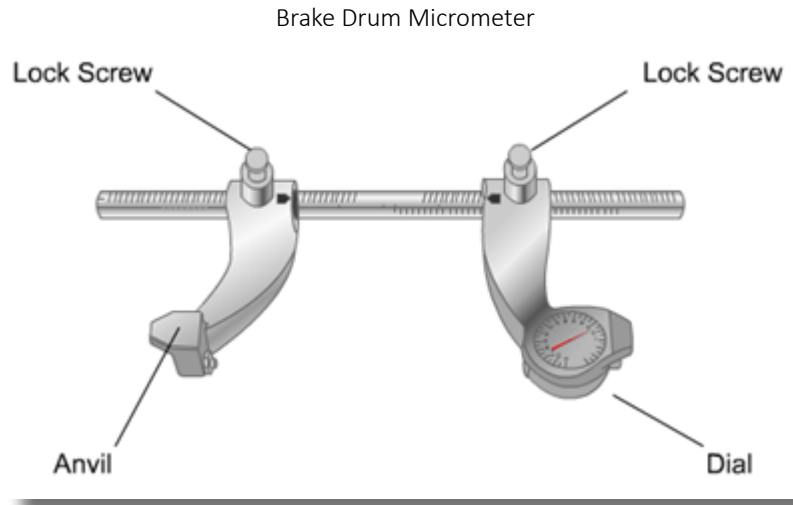

A Drum Micrometer is required to accurately measure a Brake Drum.

Using a Drum Brake Micrometer

The following is the procedure for reading an English Drum Micrometer. Refer to the image and use the measurement specifications below for this example:

Original (new) Drum Diameter:	11.375 inches
Maximum Refinish Diameter:	11.435 inches
Discard Diameter:	11.465 inches

Move the anvil leg of the Drum Micrometer along the graduated shaft until the “whole” number of the Drum Diameter (in this example, 11) is aligned on the shaft. Tighten the lock screw. Next, move the Dial Indicator leg along the graduated shaft until the “whole” number of the Drum Diameter (11) is aligned on that side. Now, move the Dial Indicator three (3) additional notches outward (you will feel a click at each notch) and tighten its lock screw.

Note: Each notch is equal to precisely 1/8 (0.125) inch and also aligns with a mark on the shaft. Therefore 3 notches are equal to 3 x 0.125 inch = 0.375 inch.

The Drum Micrometer is now set to the new Drum Diameter of 11.375 inches. In actual use, it may be necessary to move the Dial Indicator leg one notch in either direction from this point since all new drums don’t come in increments of .125 inches.

To use the micrometer, place it inside the drum and hold it flat against the rim of the drum, as shown below.

The highest reading achieved is the amount that the drum is oversized, given in thousandths of an inch.

Move the anvil leg of the Drum Micrometer along the graduated shaft until the “whole” number of the Drum Diameter (in this example, 11) is aligned on the shaft. Tighten the lock screw. Next, move the Dial Indicator leg along the graduated shaft until the “whole” number of the Drum Diameter (11) is aligned on that side. Now, move the Dial Indicator three (3) additional notches outward (you will feel a click at each notch) and tighten its lock screw.

Note: Each notch is equal to precisely 1/8 (0.125) inch and also aligns with a mark on the shaft. Therefore 3 notches are equal to $3 \times 0.125 \text{ inch} = 0.375 \text{ inch}$.

The Drum Micrometer is now set to the new Drum Diameter of 11.375 inches. In actual use, it may be necessary to move the Dial Indicator leg one notch in either direction from this point since all new drums don’t come in increments of .125 inches.

To use the micrometer, place it inside the drum and hold it flat against the rim of the drum, as shown below.

The highest reading achieved is the amount that the drum is oversized, given in thousandths of an inch.

In this case we add the dial indicator reading, 0.015 inch, to the original drum diameter setting of our micrometer, 11.375, to get our total diameter of 11.390 inches ($11.375 + 0.015 = 11.390 \text{ inches}$). To determine how much metal we can remove from this drum and still use it, we simply subtract the measured diameter from the maximum refinish diameter ($11.435 - 11.390 = 0.045$). For this example, a maximum of 0.045 inch (or 45/1000 inch) can be machined from the drum.

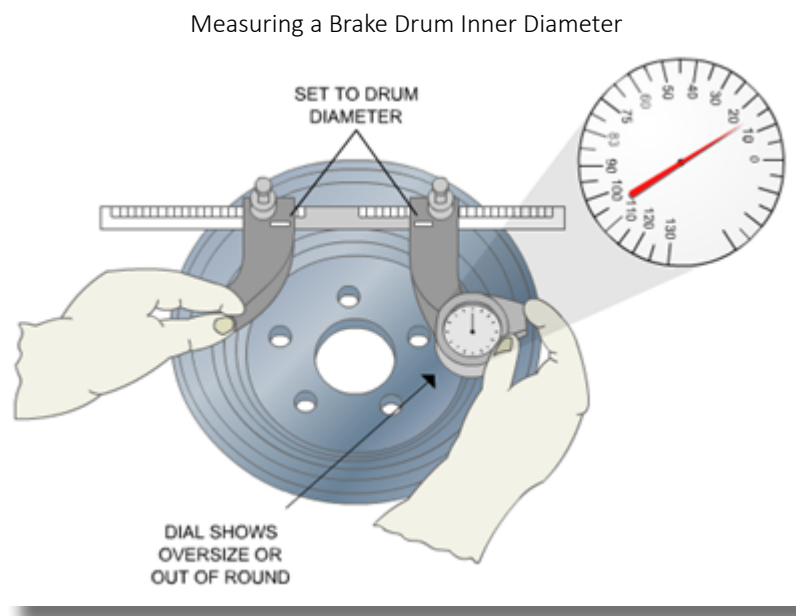

USING A BRAKE LATHE

CAUTION: The following procedure lays out the steps for properly machining (turning) a Drum on a Brake Lathe. While the Brake Lathe is a useful tool, it is still potentially dangerous if proper usage and safety rules are not followed.

Mount the Drum on the machine’s arbor (shaft) making sure to use the proper attachment hardware. Follow the manufacturer’s instructions.

Begin with all Motor Drive controls set to the neutral or ‘zero’ position.

Note: Verify that the Drum is perpendicular to the arbor and start the lathe. If the Drum wobbles, reposition it on the arbor.

Install the silencer band (usually a rubber strap wrapped around the Drum) to prevent the Drum from vibrating. Failure to use this band can result in an inferior Drum finish or 'chatter marks'.

Turn the Spindle Feed Handwheel all of the way clockwise (moving the drum to the right) until it stops; then about six turns back to the left. This will allow enough room for the drum to completely cut without running out of room.

Install the Tool Bar (or Boring Bar) making sure that the cutting tool faces, and is close to, the Drum Friction surface.

Position the Tool Bar so that the cutting tool reaches the farthest inside point of the drum. Move the cutting tool away from the Drum (as needed) with the Spindle Feed Handwheel and tighten the Boring Bar Clamp Nut.

Turn the Spindle Feed's Handwheel so that the cutting tool is positioned over the center of the Brake Friction Surface.

CAUTION: Make sure that all controls are in the neutral or zero position before turning on the lathe.

Turn the lathe ON.

Turn the Cross-Slide's Handwheel until the cutting tool barely scratches the Brake Drum surface. Set the Depth-of-Cut Collar to Zero and Turn the Cross-Slide's Handwheel clockwise two turns.

With the Drum in motion, turn the Spindle Feed's Handwheel until the cutting tool almost touches the farthest inside point of the Drum. Turn the Cross Slide's Handwheel counterclockwise two turns (back to zero), plus the desired depth of cut, and lock its Control Knob.

Set the depth of cut at no more than .010 inch for rough cuts and .004 inch for finish cuts (if desired, a .002 inch setting will give a 'polish cut').

Brake Lathe



Tool Bar (Boring Bar) Mount

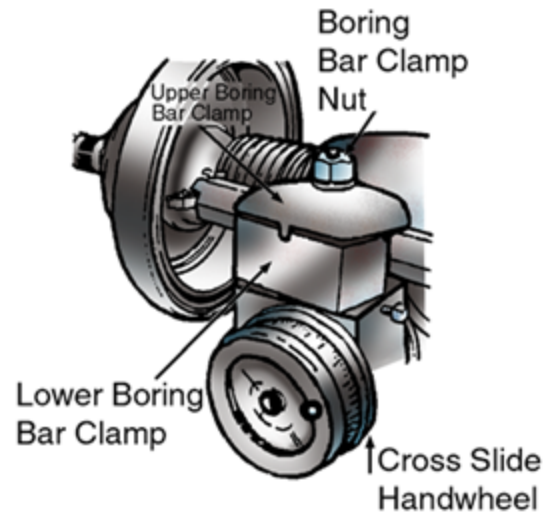

Set the Arbor Speed Control Knob at the speed desired for the cut.

Set the Arbor Travel-Limiting Collars.

Engage the arbor travel bar.

Continue taking cuts until the Friction surface is smooth and true.

- Make the last (finish) cut at the slowest speed.
- Verify that the Drum never exceeds its Discard Diameter after machining.
- Also make sure that the Drums used on the same axle are as close in diameter as possible

Lathe Controls

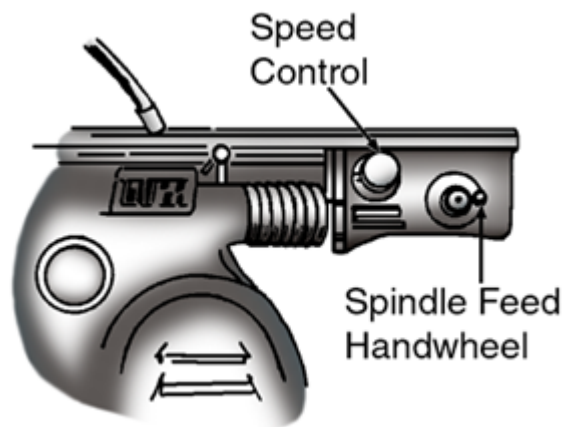

SERVICE TIPS

Always inspect and measure the Brake Drums when replacing Brake Linings, or if any of the following symptoms occur:

- Pulsation
- Brake Fade
- Chatter
- Wheel Drag
- Brakes Too Sensitive
- Spongy Pedal

Resurface Drums if:

- Taper or Out-of-Roundness exceeds 0.006 inch (0.15 mm)
- Scoring exceeds 0.060 inch (1.52 mm)

Replace Drums if:

- The maximum Diameter reading equals or exceeds the Discard Dimension.
- The Drum is under the Discard Dimension but refinishing would not leave at least 0.030 inch (0.76 mm) allowance for wear.

WHEEL ASSEMBLY

To install the Wheel and Tire Assembly:

1. Inspect the condition of Wheel Studs and Lug Nuts.
2. Replace any Studs or Nuts that are defective.
3. Check and inflate the tires to the recommended pressure.

WHEEL ASSEMBLY CONTINUED

4. Clean dirt and corrosion from the Wheel Hub mounting area and from the center pilot hole of the wheel.
5. Place the Wheel on the Hub and install the Lug Nuts finger-tight.
6. Using the proper wrench, tighten the Nuts in the correct pattern (depending on the number of lugs) to draw the Wheel evenly against the Hub.
7. Manually lower the vehicle and finish tightening the Lug Nuts, again using the correct pattern, with a torque wrench set to the manufacturer's specified torque rating.
8. If the Wheels are equipped with a Tire Pressure Monitoring System (TPMS), and they have been moved to different locations, perform the procedure to update the computer with the wheels' new locations.



Drum Should be Checked for Dirt and Corrosion Before Installation

Notice the Maximum Diameter marking on this Drum (230.0 millimeters or about 9 inches).

UNIT 4 DISC BRAKES

The following topics are addressed in this unit:

INTRODUCTION AND SERVICING CALIPERS

- Introduction
- Disc Brake Calipers
- Inspection and Diagnosis
- Removing Calipers
- Inspecting and Repairing Calipers
- Installing Calipers

ROTORS

- Reading Micrometers
- Pulsating Pedal and Brake Fade
- Rotor Refinishing
- Machining Rotors Off the Vehicle
- Machining Rotors On the Vehicle
- Break-In/Burnishing

CHAPTER 1: INTRODUCTION AND SERVICING CALIPERS

INTRODUCTION

➤ Disc Brakes

Disc Brakes are used on the front of all modern vehicles, while many have both Front and Rear Disc Brakes.

The advantages of Disc Brakes over Drum Brakes include:

- Better Fade Resistance
- Reduced Pulling and Grabbing
- Self-Adjustment Capability

Disc Brakes consist of the following components:

- Rotor
- Hub
- Caliper Assembly
- Brake Pads
- Mounting Bolts

Brake Systems must dissipate tremendous amounts of heat or the brakes will fail. Because of their exposure to the surrounding air, Disc Brakes dissipate heat more quickly than Drum Brakes. In addition, some Rotors are ventilated which allows air to circulate between the Friction Surfaces and dissipates heat even more efficiently. Since Disc Brakes can cleaner and cool themselves, they are generally considered to be more effective than Drum Brakes.

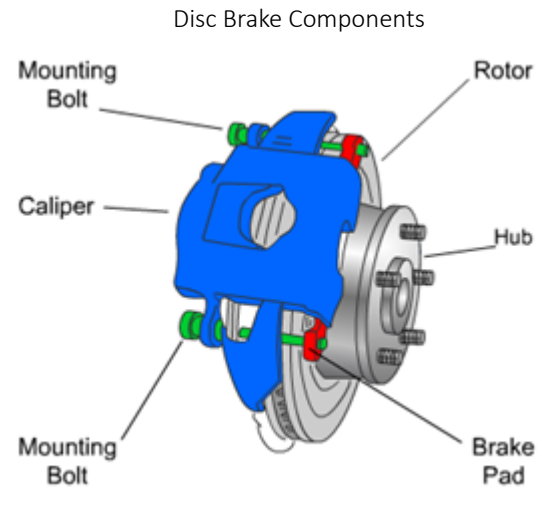

CALIPERS

➤ Disc Brake Calipers

Disc Brake Calipers convert Hydraulic Pressure from the Master Cylinder into a Mechanical Force that pushes Brake Pads against a Rotor. The Caliper body is a U-shaped casting mounted over the Rotor and is typically made of iron or aluminum.

All Calipers, regardless of design, contain these major parts:

- Caliper Body or Housing
- Internal Hydraulic Passages
- One or more Pistons
- Piston Seal(s)
- Dust Boot(s)
- Bleeder Screw
- Inboard and Outboard Brake Disc Pads
- Mounting Bolts

The most common types of Disc Brakes are the **Floating Caliper** and the **Sliding Caliper**. Both the Floating and Sliding Calipers operate similarly with the only difference being in the mounting. Specifically, Floating Calipers slide on Mounting Bolts and Bushings while Sliding Calipers operate on Machined Guides and Bushings.

Although these previous two images show 'moving' Calipers with a Single Piston, some Calipers actually have more than one Piston, mounted on the same side of the Caliper.

Disc Brakes can also have a **Fixed Caliper** design that uses at least Two Pistons. Unlike Sliding Calipers, these pistons are installed on opposite sides of the caliper, which is rigidly mounted and does not slide. Although Fixed Caliper Disc Brakes provide superior Braking Performance, they are more expensive to manufacture. As such, they are typically found only on Performance or Luxury vehicles.

Note: While Drum Brakes use Brake Return Springs, Calipers do not. Instead, Seal Deflection releases the Brake Pads on this system.

Floating Caliper Disassembled View

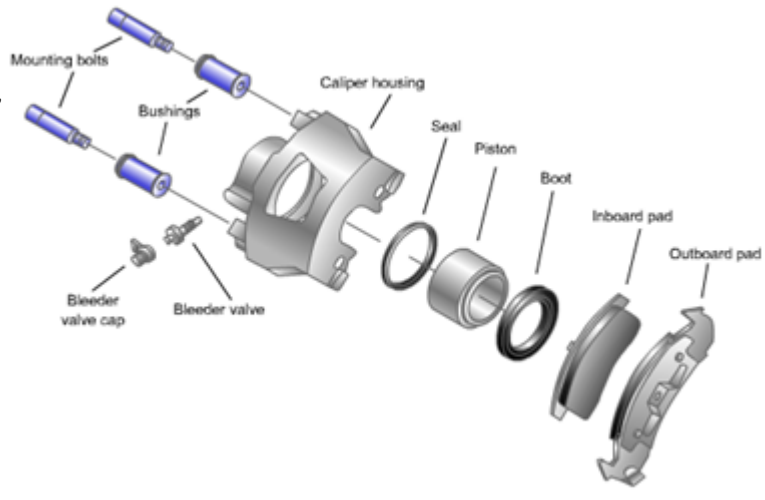

Sliding Caliper Disassembled View

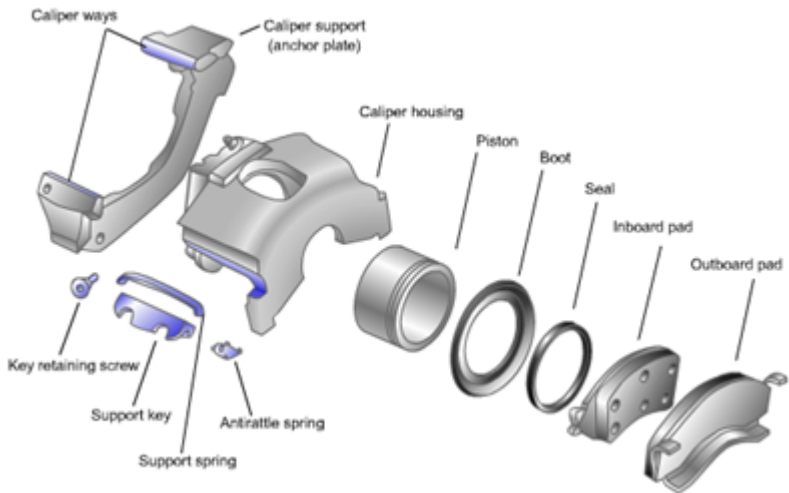

Operation of Floating Caliper Disc Brakes

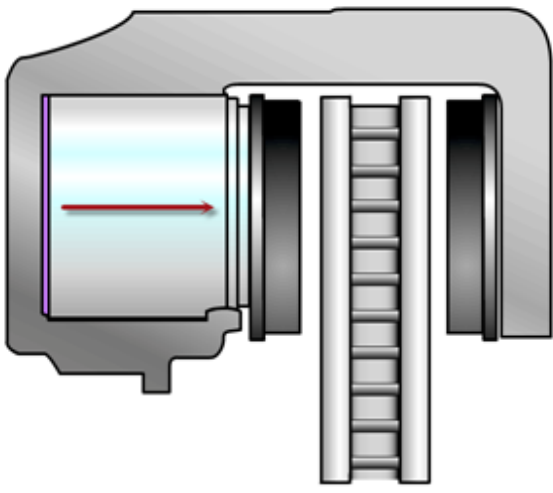

Operation of a Fixed Caliper Disc Brake

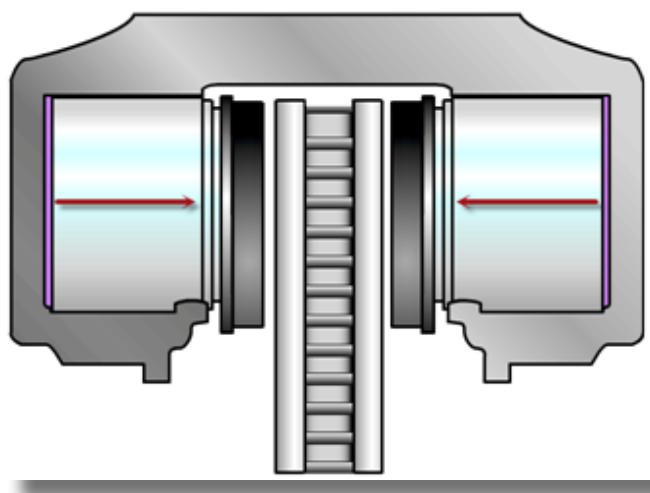

When the brake is applied the piston moves out of the cylinder and the seal flexes.

Disc Brake Seal and Piston Action

INSPECTION AND DIAGNOSIS

VISUAL INSPECTION OF A DISC BRAKE SYSTEM

Check the Fluid Level in the Master Cylinder and inspect the Hydraulic System for leaks or damage.

Use proper lifting equipment, and safe procedure, to raise the vehicle.

CAUTION: When lifting a vehicle, always use proper lifting equipment and observe all safety precautions.

Remove the wheel(s). If both Brake Pads are not visible after removing the wheel, remove the Caliper.

Use a brake cleaning device, such as a Brake Washer (air or liquid) to clean all of the Disc Brake components being serviced.

CAUTION: Do not breathe the dust that comes off of the brakes or allow it to escape into the air. If the proper equipment for working with Brake Systems is unavailable, or in poor working order, do not perform brake work.

CAUTION: Always follow the manufacturer's instructions when using the brake cleaning equipment.

Carefully inspect the Brake Assembly and note any indication of leaks. Identify the source of any leaks.

Inspect the Brake Linings.

Check the thickness of the Brake Linings on the pads.

- If a Brake Lining is riveted to the Backing Plate, the rivet heads should be more than 1/16 inch below the lining surface to be considered 'usable'. At 1/64 inch below the lining surface, the rivet can actually contact the rotor surface.
- Any Brake Lining that is bonded to the Backing Plate should be at least as thick as the Backing Plate itself.
- Replace any pads that do not clearly meet the thickness standards. Note that Brake Pads can wear unevenly, so make your reuse/replace decisions based on the thinnest part of the lining.

Disc Brake Seal and Piston Action

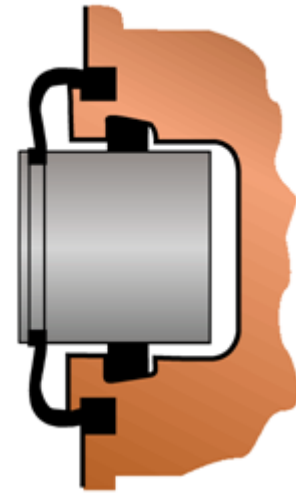

Left-New Brake Pads
Right-Used / Damaged Brake Pads



Note: All vehicles should have periodic Brake Checks, and annual checks are recommended for vehicles with more than 40,000 miles. Brakes should be checked immediately if there are any unusual sounds during braking or if the brakes fade, pull, vibrate, or lose effectiveness.

Note: If there is any doubt about the condition of the Friction Material, remove the Caliper to allow for more careful inspection.

Replace the pads if the Brake Lining is cracked, worn, glazed, distorted, or saturated with fluid. Also replace the pads if the Backing Plates are distorted or saturated with fluid.

BRAKE PAD WEAR INDICATOR SYSTEMS

There are two common types of Disc Brake Pad Wear Indicators.

The first is the mechanical or audible wear indicator, which uses a strip of metal attached to the Brake Pad and positioned to make contact with the Brake Rotor when pad wear reaches a predetermined level. The metal strip rubs against the rotor and produces a high-pitched chirping sound to alert the driver.

Break Pad Wear Indicators



The second type is an Electrical/Electronic Brake Pad Wear Indicator system. A typical Electrical/Electronic Brake Pad Wear Indicator system uses pads with electrical connectors embedded in the Brake Pad material. When the pads wear to a predetermined point, the electrical connectors in the pad come into contact with the Rotor surface, which will open (or ground, depending on design) the circuit and illuminate a Warning Light on the instrument panel. To turn the Warning Light off, it is typically necessary to replace the Brake Pads, and on some vehicles, perform a Warning Light Reset Procedure.

REMOVING CALIPERS

Remove the wheels.

- Mark the wheels for reinstallation in their original locations, unless a Tire Rotation is also being performed.
- Inspect the wheels for cracks and check the tires for unusual wear patterns. Store the wheels so that the wheel covers do not become damaged.
- Identify whether the Calipers to be serviced are of the Sliding or Floating type. Either type can have either one or two pistons in the Caliper.
- Clean all of the brakes to be serviced.

Take off the Master Cylinder cover and remove a small amount of fluid from each chamber. Doing so will prevent fluid overflow when the Caliper Pistons are compressed.

CAUTION: Brake Fluid can harm a vehicle's finish. Do not let the fluid overflow or spill.

Note: Before removing any Caliper, it is a good idea to first loosen the Bleeder Valve. That will make it easier to work with later.

If a Caliper's piston is not seized or leaking, and its seals are not distorted or cracked, then it can typically be reused without rebuilding simply by compressing the piston back into the Caliper.

Compressing pistons is sometimes most easily done before the Caliper is removed due to the leverage that comes from using the Rotor and mounting bracket.

Compressing Pistons on Sliding or Floating Calipers

- Place a large C-clamp on the Caliper with the head of the clamp on the back side of the Caliper and the screw against the outer Brake Pad.
- Turning the screw will force the Outer Pad against the Rotor and, as a result, the Caliper will slide toward the Rotor and push the piston back into the Caliper bore.

Remove the Caliper from the Caliper Support or Mounting Bracket.

Note: Be sure to disconnect the correct Caliper bolts as it is a common mistake to remove the entire Mounting Bracket when it isn't necessary.

Inspect all of the attachment hardware and note any broken or worn parts. They will need to be replaced.

If the Caliper is going to be reused without being rebuilt, hang it up using a piece of wire or welding rod. **Never allow a Caliper to hang by its Brake Hose.**

If the Caliper is going to be rebuilt or replaced, disconnect (unscrew) the Hydraulic Hose completely from the Caliper.

For Brake Hoses that are connected with a banjo bolt, disconnect the hose at the Caliper.

If the disconnect fitting is at the end of the Brake Hose away from the Caliper, leave the hose attached to the Caliper.

If the cover is still off the Master Cylinder, put it back on.

Note: If the Brake Hoses are going to be left open for a long time, tape them up to avoid contamination from dirt and moisture.

REPAIRING CALIPERS

Clean all of the brake components to be used or reused.

Note: Use only an approved brake cleaning solvent to clean brake components. Never use an engine solvent or gasoline.

Brake Caliper Tools



Remove the piston(s), from either a Sliding or Floating Caliper, using the procedures below, and disassemble the Calipers.

- Remove the Bleeder Valve.
- Turn the Caliper face down (the way it is mounted in a vehicle) on a bench, and place it over a block of wood.
- Lay a rag over the Caliper to avoid spraying Brake Fluid.
- Use compressed air in the Bleeder Valve port to blow out the Piston.

CAUTION: Caliper pistons can blow out with enough force to cause personal injury. Always keep your hands clear of the inside of the Caliper, and keep others out of the area.

CAUTION: Do not use a torch or machine tools to remove the pistons; doing so may ruin the Caliper.

Note: It may take considerable time to remove stuck Caliper pistons. If the pistons are stuck so securely that normal removal procedures cannot free them, then the bores are probably corroded and the entire Caliper needs to be replaced.

With the pistons removed, inspect the Caliper components.

After cleaning all the internal parts with an approved brake solvent, inspect the pistons for pitting, rusting, cracks, chipping, and scoring. If any of these problems are found, replace the pistons.

Note: Whether damaged or not, always replace plastic (sometimes called composite) pistons after removal.

Remove all Seals and Boots from the Caliper bores (DO NOT use a metal pick as it can scratch the bore) and check them for pitting or scoring. Clean the bores with a fine crocus cloth or Caliper hone if doing so does not increase bore Diameter by more than .002 inches. If there is any bore damage deeper than .001 in, replace the Caliper.

Note: Discard all seals, boots, and any other rubber Caliper parts.

Remove and clean the Bleeder Valve; replace it if necessary.

Reassemble the Caliper.

- During reassembly, lubricate all parts liberally with clean Brake Fluid. All parts should move freely into their proper positions; inspect any part that does not fit easily. Do not force the pistons into their bores.

Disc Brake Caliper Disassembled View

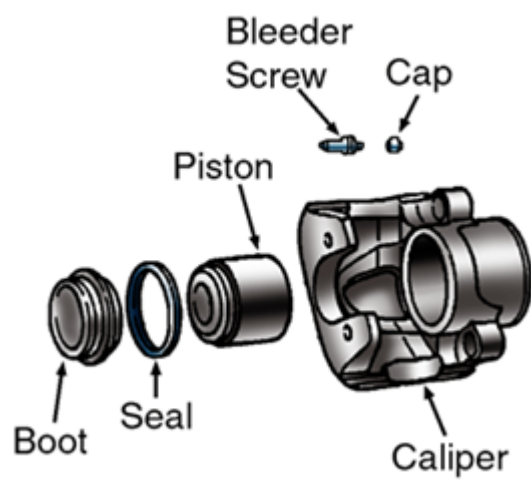

- Using only new soft parts, manually insert all seals and pistons into the Caliper bores. Do not use excessive pressure while pressing pistons to the bottoms of their respective bores.
- Install a new Dust Seal according to the manufacturer's directions.

INSTALLING A DUST SEAL

- Inspect all Hoses and replace any that show evidence of leaking or deterioration.
- Reinstall all Bleeder Valves.

INSTALLING CALIPERS

Inspect the Caliper Mounting Bracket attachment hardware. If servicing a Sliding Caliper, inspect the surface upon which the Caliper slides. Repair any worn areas and thoroughly clean the adapter and knuckle.

Clean and lightly lubricate all attachment hardware.

Inspect the Rotors for proper Parallelism, Runout, and Minimum Thickness and make sure they are not grooved in excess of allowable limits. Repair or replace Rotors as necessary.

Note: Service or replace the Rotors as needed before installing the Calipers.

Using the manufacturer's service manual procedure, install the Brake Pads securely in the Caliper.

Install the Caliper in the Mounting Bracket.

Note: Floating or Sliding Calipers used on Front Wheels will 'Self Adjust' when the pedal is pressed, and therefore require no manual adjustment.

Attach the Brake Hose to the Caliper.

CAUTION: Until the Caliper Pistons return to their operating positions next to the rotors, the brakes will be inoperative. The Brake Pedal may need to be applied several times before the pistons resume their operating positions. Make sure the brakes are operative before driving the vehicle.

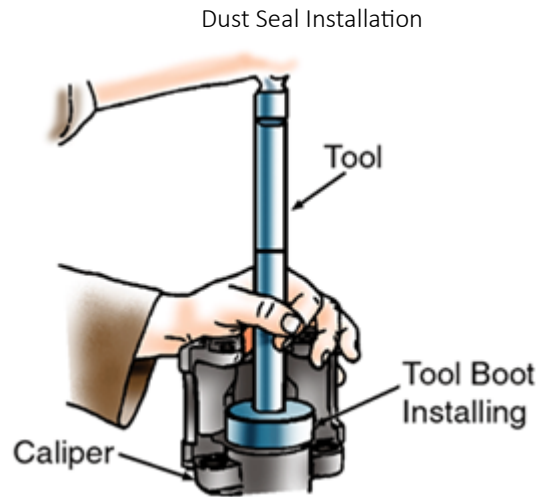

Caliper Mounting Bracket with Guides



Rear Caliper Parking Brake Cables and Linkage



Bleed the air from the Lines, Hoses, and Calipers using the proper order for either a Front/Rear-Split or Diagonally-Split System (depending on which you have). Remember to frequently check the level of Brake Fluid in the Master Cylinder.

If installing a Rear-Wheel Caliper, connect the Parking Brake Cable and adjust the Parking Brake according to the manufacturer's procedure.

Note: There are numerous designs of Parking Brake mechanisms used on Rear Disc Brake vehicles including the Shoe and Drum and the Screw-Actuated (which is an integral part of the Caliper) types. Procedures for service and adjustment of these systems differ and you should always refer to the manufacturer's recommended procedure.

Reinstall the Wheel/Tire Assembly and torque the Wheel Lug Nuts to specification.

CAUTION: Always check and refill the Master Cylinder after testing or servicing Hydraulic System components.

CAUTION: Make sure the Hydraulic System is free of air after testing or servicing.

CHAPTER 2: ROTORS

READING MICROMETERS

The next few sections in Disc Brakes involves working with Brake Rotors. An important part of this process will involve measuring Rotor dimensions using a tool known as a Micrometer.

Micrometers are available for making both English and Metric measurements, and since this is likely the students first exposure to these devices, it is important to discuss them before continuing with Disc Brakes.

The following section covers both general information about Micrometers, as well as how to use both English and Metric types.

MICROMETERS

The major components of a micrometer are:

- Frame
- Spindle and Thimble
- Sleeve
- Anvil
- Ratchet
- Locknut

The spindle and thimble are made together and are threaded into the sleeve. When the thimble is rotated, the thimble and spindle move in or out on precision threads.

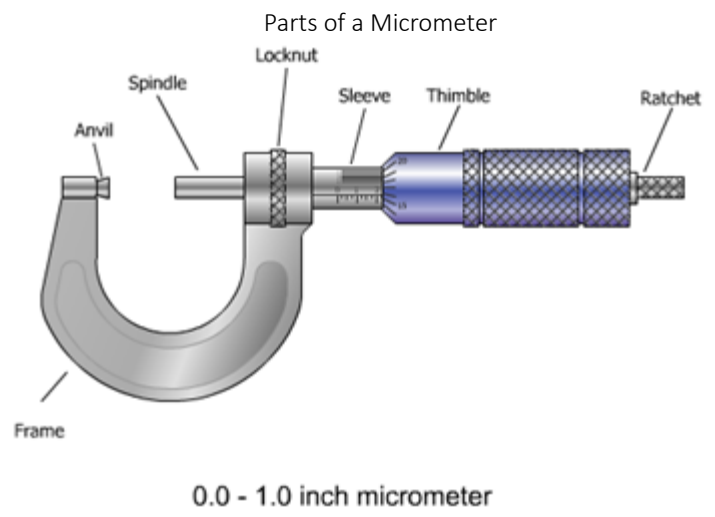

Reading an English Micrometer (0 to 1 inch)

A one-inch Micrometer always measures a fraction of one inch, and measurements are made in four easy steps.

A larger Micrometer (2 inch, 3 inch, etc.) will read the same way as the 1 inch, it will just add the difference. For instance, a 2 inch Micrometer will add 1 inch to the measured reading, a 3 inch Micrometer will add 2 inches to the measured reading, and so on.

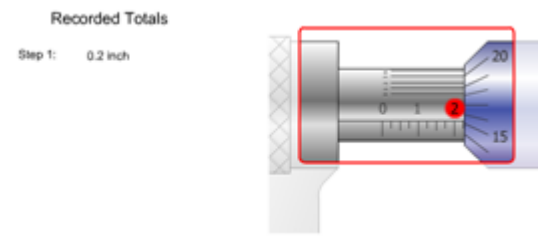

Read the largest number that is exposed on the sleeve as shown in the figure. In this case the largest number exposed is 2. Record this value in step 1 as 0.2 inch (200/1000 inch).



Count the number of marks that are exposed to the right of the number 2 in the figure. Each mark equals 0.025 inch, so in this example, one mark is exposed for a total of .025 inch (1 X 0.025 = 0.025). Record this in step 2 as 0.025 inch (25/1000 inch).

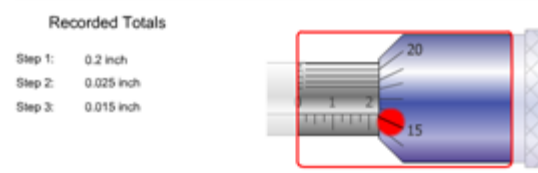

Next we find the line number on the thimble that aligns with, or is just below, the horizontal line on the sleeve. The sleeve line in this example is between 15 and 16. Record this in step 3 as 0.015 inch (15/1000 inch).

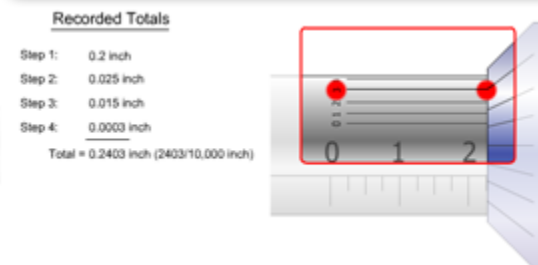

The Vernier Scale, used for the most precise measurement, is located on top of the sleeve. Look for the one Vernier line that most perfectly aligns with any line on the thimble. In this case, Vernier line number 3 aligns with the thimble most closely. Record this in step 4 as 0.0003 inch (3/10,000 inch).

Now we simply total the numbers recorded in step 1 through step 4.

Step 1 0.200

Step 2 0.025

Step 3 0.015

Step 4 0.0003

Total= 0.2403 inch (2403/10,000 inch)

That was easy enough so now let's try a couple of examples. The first one will be an English Micrometer without a Vernier Scale.

Now it's time to move on to Metric Micrometers. If you are wondering why we have to learn the Metric Mic, it's because vehicles are now designed and built, bumper-to-bumper, in metric dimensions. Also, since only three of the world's countries still use the English System, it is more applicable.

READING A METRIC MICROMETER

Reading a Metric Micrometer is similar to reading an English Micrometer except that there are typically only three readings instead of four. On a Metric Micrometer the upper scale of the sleeve measures in 1.0 mm (millimeter) increments while the lower scale measures 0.5 mm increments. The thimble is divided into fifty (50) equal parts of 0.1 mm each which means that one complete revolution of the thimble equals 0.5 mm. Note that Metric Micrometers typically do not have a Vernier scale.

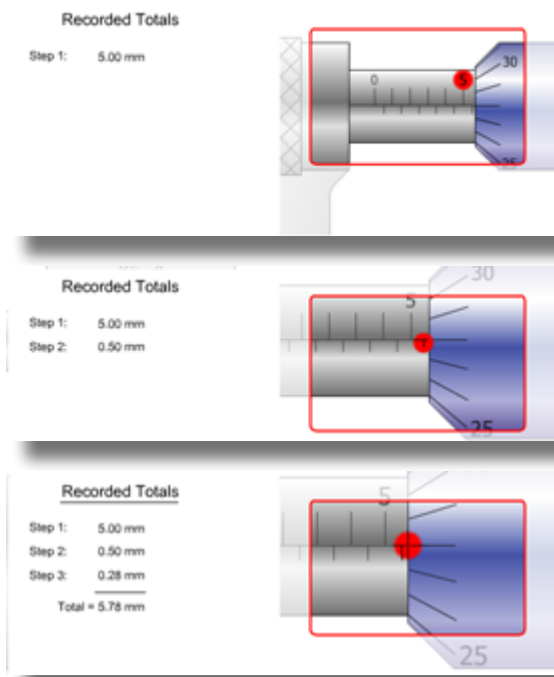

Read the largest number that is exposed on the upper scale of the sleeve as shown in the figure. In this case the largest number exposed is 5. Record this value in step 1 as 5.00 mm.

Next, is there a line exposed on the lower scale of the sleeve after the number on the upper sleeve? If so, record this value in step 2 as 0.50 mm. If not, add nothing.

Finally, we find the line number on the thimble that aligns with, or is just below, the horizontal line on the sleeve. The sleeve line in this example reads 28 so we record this value in step 3 as 0.28 mm.

Now we simply total the numbers recorded in step 1 through step 3.

Step 1 5.00
Step 2 0.50
Step 3 0.28
Total= 5.78 mm

PULSATING PEDAL AND BRAKE FADE

Braking problems caused by Disc Brake Rotors tend to fall into one of three categories: Pedal Pulsation, Brake Fade, or Squealing. Since Squealing is more an annoyance than an actual braking problem, we'll put our emphasis on the other two.

Pedal Pulsation and/or Brake Fade are typically the result of problems in one or more of the three Rotor measurement areas. They are:

- Parallelism or Thickness Variation
- Lateral Runout
- Minimum Thickness

PARALLELISM OR THICKNESS VARIATION

Although these two terms are used together here, they are not exactly the same thing.

Parallelism is when the two sides of a Rotor are flat and the same distance apart all of the way around the Rotor. **Thickness Variation** is the test we conduct to determine whether or not a Rotor is Parallel. However, since they are related, we will list them together.

A Rotor that is not Parallel will have Thicker and Thinner sections around its surface. During braking, those Thickness Variations will tend to let the Disc Pads move toward the Rotor then push them back out again. This is felt in the Brake Pedal as a 'pulsing' motion.



Thickness Variations can be caused by excessive heating and cooling of the Rotor, and even small variations can cause adverse braking conditions.

DETERMINING IF ROTORS ARE PARALLEL

Use proper lifting equipment, and safe procedure, to raise the vehicle and remove the wheel and caliper. The Rotor may or may not need to come off depending on the accessibility.

CAUTION: When lifting a vehicle, always use proper lifting equipment and observe all safety precautions.

Before making Thickness Variation checks, examine the Rotor for grooves.

- If significant grooves are not found, continue to test the Rotor for Parallelism.
- If significant grooves are found, measure the depth of the grooves.
- If grooving causes the Rotor to fall below its Minimum Thickness (Discard Thickness cast into the Rotor) at any point, discard the Rotor.
- If the Rotor is above its Minimum Thickness, it may be possible to machine the grooves out of the Rotor. However, do not machine the Rotor below its Minimum Thickness.

Note: Some Rotors have grooves machined into them from the manufacturer for dust control and cooling. Do not measure these grooves, or machine them out.

Using a Rotor Micrometer, measure the thickness of the Rotor at 4 to 12 (depending on the size of the Rotor) different equally distant points around its perimeter, and about 1 inch (25mm) in from the outer edge. Record and compare the measurements. If any one reading exceeds any of the others by .001 inch (.025mm) or more, the Rotor is not parallel.

Measuring Rotor Thickness Variation

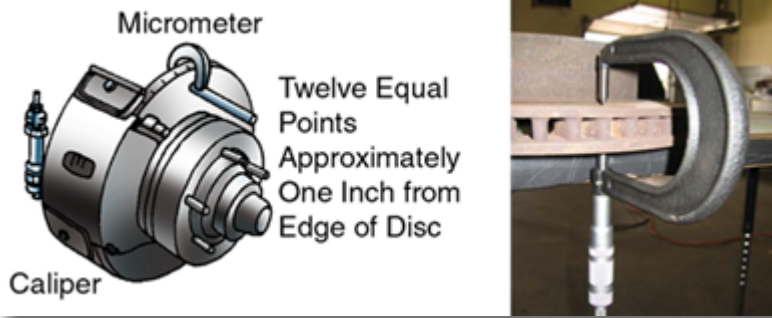

In addition to comparing these thickness measurements to each other, compare them also to the Minimum Thickness specification which is cast into the Rotor or its hub. If any of the thickness measurements are less than the specification, discard the Rotor.

Measuring a rotor for thickness variation

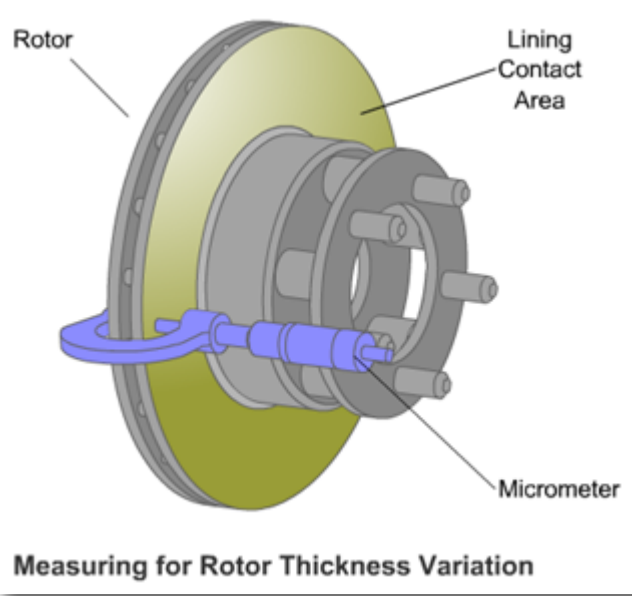

Also, if the Rotor is **not** parallel, calculate what the Rotor's thickness will be if it is machined to the smallest micrometer measurement.

- If machining will drop the Rotor below the Minimum Thickness specification, discard the Rotor
- If machining will not drop the Rotor below its Minimum Thickness, machine the Rotor until there is no more than .001 inch (.025mm) variation between any two points.

Four locations for rotor measurement

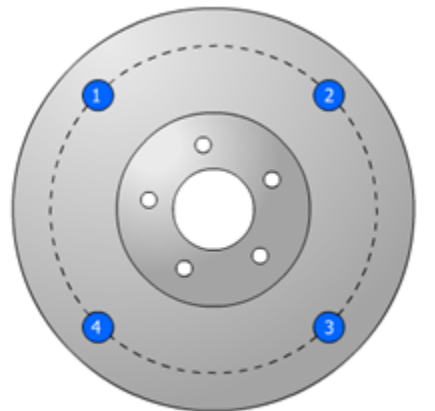

Measure rotor in four or more locations.

Precision Brake Micrometers must be used when measuring the Thickness Variation of Brake Rotors. A difference of more than 0.0006 inch (0.0152 mm) between four measurements (or as many as twelve measurements when, for instance, trying to verify a specific customer complaint) may require that the Rotor be refinished or replaced during brake service (refer to vehicle service manual for specifications).

ROTOR LATERAL RUNOUT

If the Rotor is parallel, the next step is to measure the Rotor Lateral Runout (side-to-side movement).

Measuring Rotor Runout

Rotors with too much runout may cause a pulsating pedal or brake fade. Outlined below is a procedure for measuring rotor runout.

Note: If the rotor is not integral with the hub assembly, retighten the wheel nuts onto the hub to hold the rotor in place. In some cases, it may be necessary to install a spacer before installing the wheel nuts. Follow the manufacturer's recommended procedure.

With the vehicle properly supported and the wheel off, fasten a Dial Indicator base to the spindle, knuckle, or some other solid area that allows the indicator to touch the disc.

Adjust the Dial Indicator so that it contacts the Rotor somewhere near, and perpendicular to, the center of the friction surface.

Rotate the Rotor while watching the Dial Indicator.

Stop and zero the Dial Indicator at the point of its lowest reading.

Continue turning the Rotor.

- Stop the Dial Indicator at its highest reading.
- Subtract the lowest reading from the highest reading; the difference is the Rotor Runout.
- If there is no difference between the lowest and highest reading, then the runout is zero.
- If the difference is greater than .005 in, machine the rotor.

Dial Indicator Location

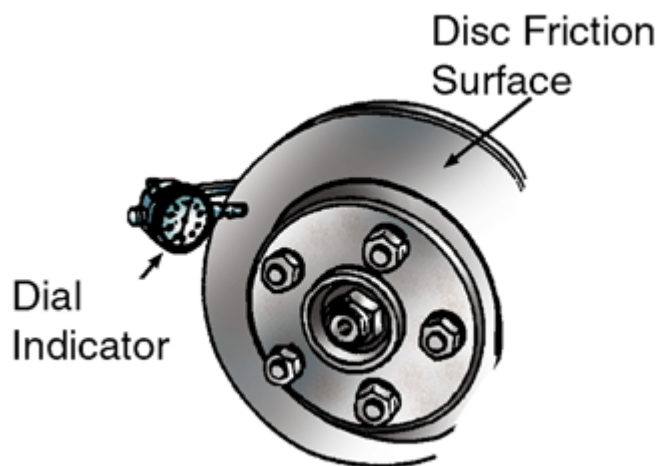

Dial Indicator Setup for Measuring Lateral Runout

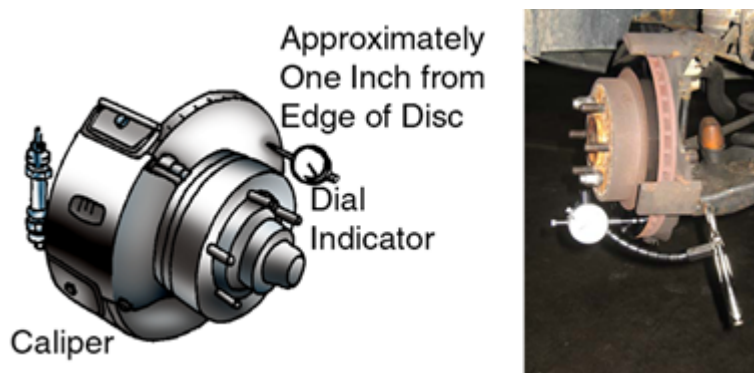

Note: A worn or poorly adjusted bearing can cause excessive Rotor Runout. Inspect the bearing for excessive wear and check the bearing adjustment before machining rotors.

To remove runout, reduce the rotor thickness by one half of the runout measurement. For example, if the runout is .006 in, then reduce the rotor thickness by .003 in.

Calculate the thickness of the rotor if it is machined. If the thickness is less than the Minimum Thickness specifications, discard the rotor. If the thickness still exceeds the Minimum Thickness specifications, machine the rotor until runout is under .001 in.

In this figure the Dial Indicator needle moved -0.002 inch (0.051 mm) and then $+0.003$ inch (0.076 mm). The total runout is therefore 0.005 inch (0.127 mm) and could indicate that the rotor needs to be refinished or replaced (refer to vehicle service manual for specifications).

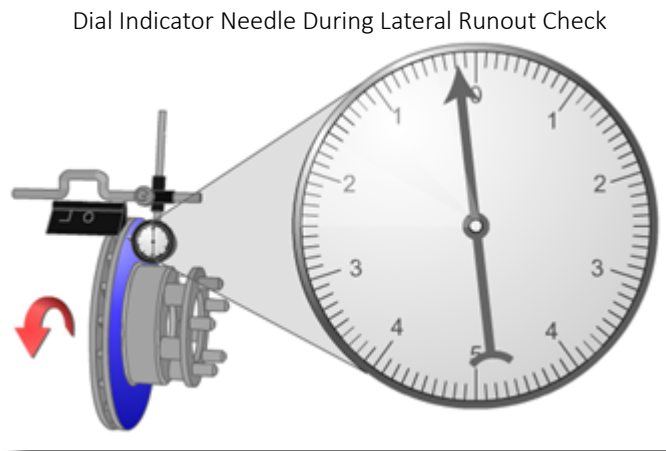

BRAKE FADE

Although we have already mentioned the Minimum Thickness specification, and how it determines whether a Rotor can be reused or discarded, students need to understand why it is important. Recall that automotive brakes (Drum or Disc) work by converting Kinetic Energy (Motion Energy) into Heat Energy, and then dissipating that heat. As a Rotor becomes thinner, it has less metal to dissipate heat, which can allow overheating of the Rotors or even cause the Brake Fluid to boil. The vehicle would then suffer from Brake Fade, which is a significant loss of braking ability, and all of the problems that would cause. Simply, a Rotor below Minimum Thickness has too little metal in it to work effectively.

Brake Fade was covered in more detail in the 'Heat' section of Brake System Fundamentals.

ROTOR REFINISHING

Rotors should be refinished only in cases of:

- Excessive Thickness Variation
- Excessive Lateral Runout
- Excessive Surface Scoring



Additionally, there are two specifications that must be observed when refinishing Rotors:

Discard Specification

- This specification is usually stamped or cast into the rotor. Rotors can be reused to this 'Minimum Thickness' specification **if the Rotor is not refinished.**

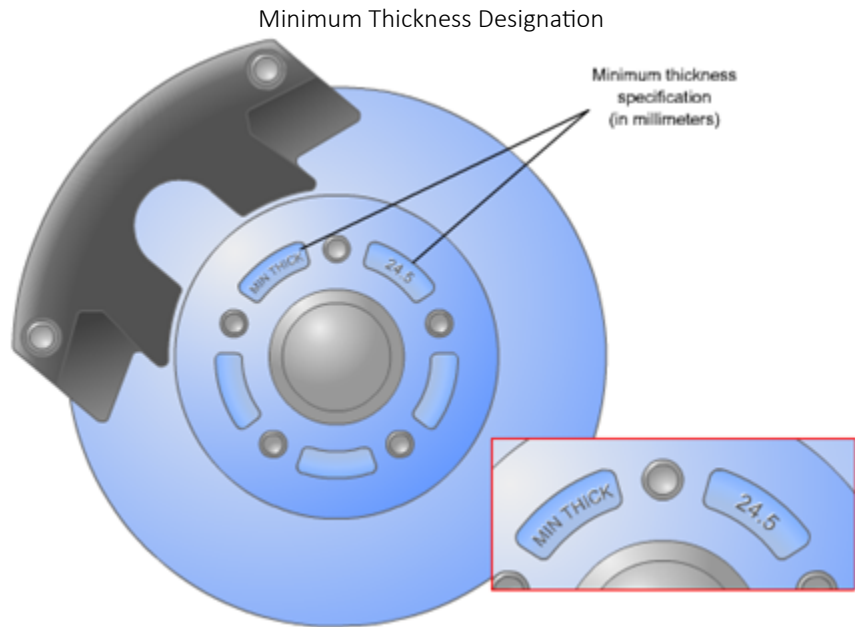

Minimum Refinish Specification

- This specification is found in the vehicle service manual and is the Minimum Thickness to which a Rotor can be refinished. The difference between the Discard and Refinish specifications is to allow for the wear that takes place as the new pads burnish, or wear into, the refinished rotor.

MACHINING OFF VEHICLE

PREPARATION TO MACHINE ROTORS

Mount the Rotor on the Brake Lathe arbor.

Note: Be sure to center the Rotor between two of the arbor's cones. If the Rotor wobbles when turned, it is not correctly connected to the arbor. Also ensure that no dirt or metal chips are caught between the Rotor and arbor.

Install the Rotor Silencer to prevent vibration chatter during machining. Typically, the silencer is a rubber band that stretches around the Rotor's edge or a pad that contacts the Rotor's face.

Installing a Silencer Band

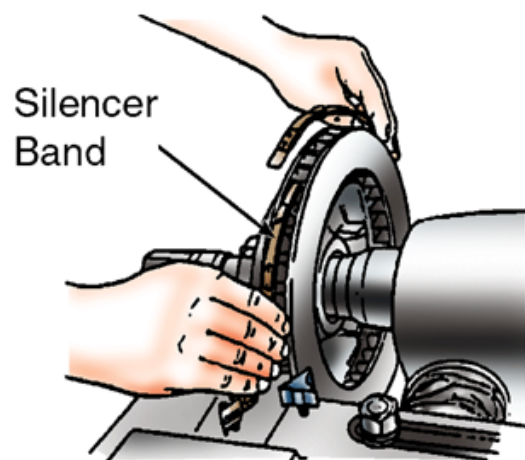

Install the cutting head, making sure to center the Rotor between the cutting tools or bits. Also make sure that the cutting tools are perpendicular to the arbor.

Turn the Cross Slide Handwheel until the cutting bits are at the midpoint of the Rotor's Friction Surface.

Using hand pressure, rotate the Rotor at least one complete revolution making sure that it turns freely and that both tool bits are clear of the Rotor's surface.

CAUTION: Make sure that all motor drive controls are in neutral, or at zero, before turning the lathe ON.

Turn the lathe ON and visually examine the rotor to insure that it is turning 'true' and isn't wobbling. If it is turning true, then continue with the machining. If not, turn the Lathe OFF, loosen the Arbor Nut, and realign the Rotor to make it straight on the machine.

Once the Rotor is turning true, turn the Lathe ON and follow these steps:

- Loosen the Tool Bit Locking Knobs
- Turn one of the Tool Bit Control Knobs clockwise until the tool bit just makes contact with the Rotor's surface.
- Turn the indexing collar on the knob to Zero.
- Back that Control Knob off one half turn.
- Repeat this procedure with the other Tool Bit Control Knob.
- After setting the collars, leave them in the same position during the entire machining process. The collars indicate how much material is being removed.

Brake Lathe Controls for Rotors

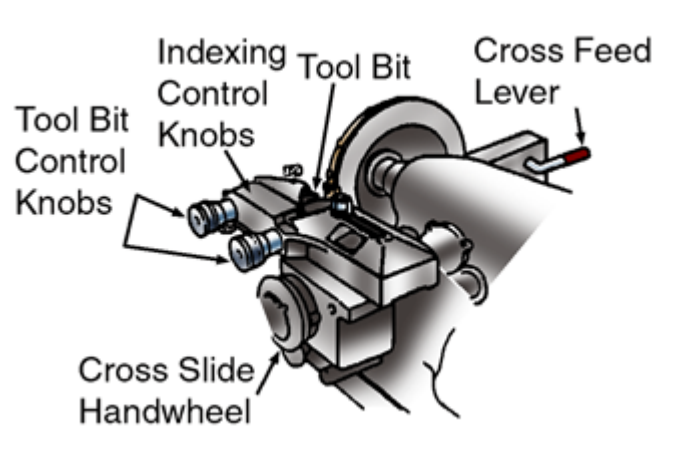

MACHINING A ROTOR

After the 'Zeroing' is done, turn the Lathe OFF, then:

- Turn the Cross-Slide Handwheel clockwise until the Tool Bits are just past the inner edge of the Rotor's surface.
- Turn the Tool Bit Control Knobs (Depth-of-Cut Knobs) past the prior 'Zero' setting to indicate the desired depth of the first cut. Then lock them in this position with the Locking Knobs.

Note: If the first cut is made at High Speed, then the depth should not exceed .010 inch. If the total cut needed is less than .010 inch, then set the depth at that dimension and run the first cut at Low Speed.

- Engage the Cross-Feed Lever. The lever has two positions: High and Low. High Speed is for a rough cut and Low Speed is for a finish cut.

Note: The cut depth for a regular pass should be no more than .010 inch, while a .004 inch depth works well for finish cuts and a .002 inch depth is for polish cuts, if desired.

- Continue taking cuts until the Rotor is smooth and true. Check the Rotor's Thickness, Parallelism, and Lateral Runout after making the final cut, but before removing the Rotor from the arbor.

Note: When measuring a Rotor to make sure it is not below Minimum Thickness, it is important to also check that the two sides of the Rotor are of equal thickness. It isn't acceptable for a Rotor to be above Minimum Thickness if one side is like new while the other is significantly worn down.

Using a sanding block or other abrasive, put a nonsymmetrical finish on the Rotor's Friction Surface in this way:

- Turn the Brake Lathe ON.
- Lightly drag the abrasive across the machined surface of the Rotor.
- Turn the Brake Lathe OFF.

Remove the Rotor and clean it with an approved solvent to remove all of the metal particles.

MACHINING ON VEHICLE

PREPARATION FOR MACHINING ROTORS

Remove the wheel from the brake to be serviced and clean the brake parts as previously outlined. Again, do not breathe the dust or allow it to escape into the air.

Remove the Disc Brake Caliper using the correct procedure.

Visually inspect and measure the Rotor for Parallelism, Lateral Runout, Scoring, and Minimum Thickness to determine if it can be resurfaced or must be replaced.

On-Vehicle Brake Lathes

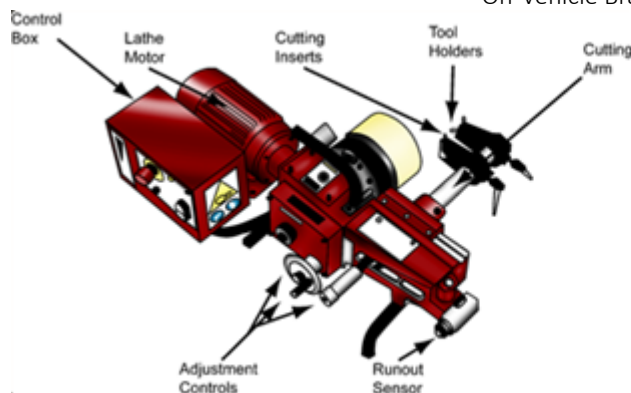

Brake Machine Setup to Turn Rotors



CONNECTING THE BRAKE LATHE

Select the correct Hub Flange Adapter to fit the vehicle's Rotor/Hub Assembly.

After verifying that all mounting areas are sufficiently clean, mount the Hub Flange Adapter to the Rotor/Hub Assembly.

Attach the Brake Lathe to the Hub Flange Adapter.

CAUTION: Be sure the Lathe is properly aligned and mounted to avoid damaging the flange.

Following the Brake Lathe manufacturer's directions, attach a Dial Indicator and compensate for hub and adapter runout.

Note: Some Brake Lathes have the ability to self-compensate.

On-Vehicle Brake Lathe in Mounted Position

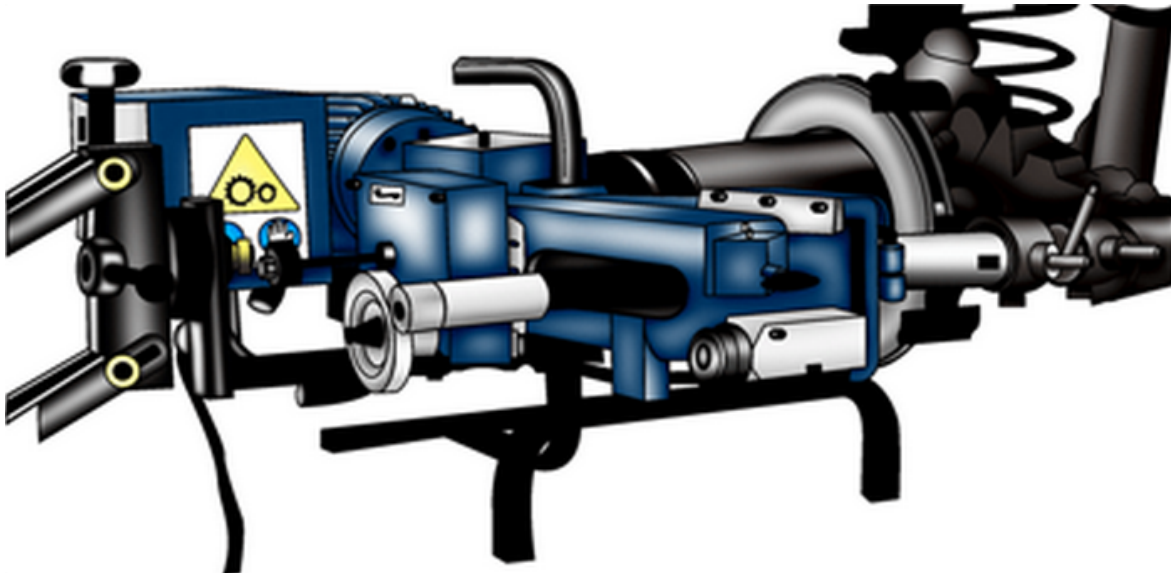

MACHINING THE ROTOR

Install the Rotor Silencer.

Check the condition of the Cutting Inserts.

Move the Cutting Arm to the center of the Rotor surface and adjust the Cutting Inserts to just contact the Rotor. This will set the 'Zero Point'.

Setting Cutting Bits to 'Zero Point'



Back the Cutting Inserts away from the Rotor surface slightly and reposition the Cutting Arm to the inner diameter of the Rotor's inboard and outboard friction surfaces.

Note: As we have seen before, .010 inch is an acceptable cut depth for a standard pass. A finish cut should be about .004 inch and .002 inch is for polish cutting.

Turn the Brake Lathe ON.

Engage the feed mechanism.

CAUTION: To avoid damaging the Rotor, do not disturb the lathe once the feed mechanism has been engaged.

Machine the Rotor's surface, adjusting the cut depth and speed as needed.

Remove the Brake Lathe from the adapter. Be careful not to hit the Rotor with the Cutting Inserts while removing the lathe.

Check the Rotor's Parallelism (Thickness Variation) and Lateral Runout before removing the adapter. Be sure that the Rotor is above the manufacturer's Minimum Thickness specification.

Note: When measuring a Rotor to make sure it is not below Minimum Thickness, it is important to also check that the two sides of the Rotor are of equal thickness. It isn't acceptable for a Rotor to be above Minimum Thickness if one side is like new while the other is significantly worn down.

Remove the Hub Flange Adapter.

Reinstall the Brake Caliper and Pads using the service material procedure.

Depress the Brake Pedal and check brake operation.

Reinstall the Wheel-and-Tire Assembly and torque the Lug Nuts to the proper specification.

Repeat the procedure on other Rotors as required.

BREAK-IN/BURNISHING

Many vehicle and brake component manufacturers recommend performing a Brake Pad Break-In/ Burnishing procedure to condition the Brake Pads and Rotors following the installation of new Brake Pads.

Lathe Just Beginning First Cut.
Notice the 'Zero Point' cut near the edge.



Commonly recommended Brake Pad Break- In/Burnishing procedures include the following steps:

- Select a straight section of highway with a speed limit of 55 MPH or more, and little traffic.
- Perform 5 to 8 moderate brake applications from 40 to 10 MPH
- Perform 5-8 rapid deceleration brake applications from 60 to 10 MPH
- Drive 1.5 to 2 miles (allow the brakes to cool)
- Perform 5-8 rapid deceleration brake applications from 60 to 10 MPH

Note: Some brake smoke and odor may result from the Break- In/Burnishing procedure; which should be considered normal.

UNIT 5 POWER ASSIST SYSTEMS

The following topics are addressed in this unit:

POWER ASSIST SYSTEMS OVERVIEW AND DIAGNOSIS

- Vacuum Assist Booster System
- Hydraulic Assist Booster System
- Diagnosing Hydraulically-Assisted Power Brakes

Most modern vehicles are equipped with a Power Assist (Boost) System to aid the driver when applying the brakes.

The two most common types of Assist Systems are **Vacuum Assist** and **Hydraulic Assist**.

VACUUM ASSIST

A **Vacuum** is a condition in which the pressure of a specific area is less than the surrounding Atmospheric Pressure. The difference between Vacuum Pressure and Atmospheric Pressure is known as a Pressure Differential, or just Differential Pressure. Vacuum Assist Booster Systems use a Differential Pressure to manipulate a flexible membrane, known as a Diaphragm, to aid in brake application.

Specifically, Automotive Vacuum Assist Power Brake Systems use the difference between engine **Manifold Vacuum** (a negative pressure within the Intake Manifold) and **Atmospheric Pressure** (approximately 14.7 pounds per square inch (psi) at sea level) to provide power assist for brake applications.

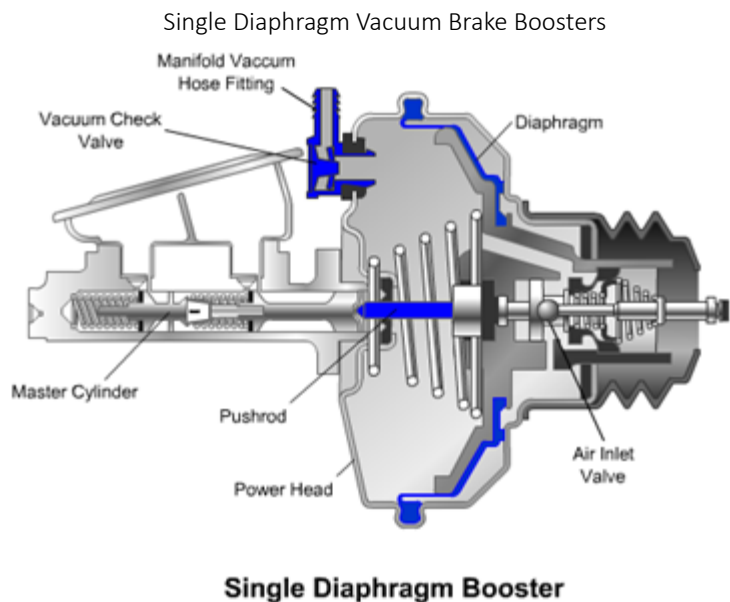

Vacuum-Operated Power Brake systems also use a Check Valve in the booster body to hold vacuum in the booster for assist during low-vacuum conditions.

Note: On engines that do not have high manifold vacuums, such as diesels or gasoline engines with high performance packages, a Vacuum Pump is usually required for the Power Brake System.

The two types of Vacuum Boosters used on modern vehicles are the Single-Diaphragm and Tandem-Diaphragm (or Dual-Diaphragm). Both booster types operate similarly, but since the Tandem-Diaphragm booster is smaller in diameter, it is more commonly used due to space limitations.

HYDRAULIC-ASSIST

Hydraulic-Assist Brake Systems are used on many vehicles which have either limited space under the hood or engines that cannot consistently produce sufficient vacuum to operate a Vacuum-Assist Power Boost System. These applications include:

- Diesel engines
- Turbocharged engines
- Engines that operate at high load (low vacuum) such as truck applications.

Tandem Diaphragm Vacuum Brake Booster

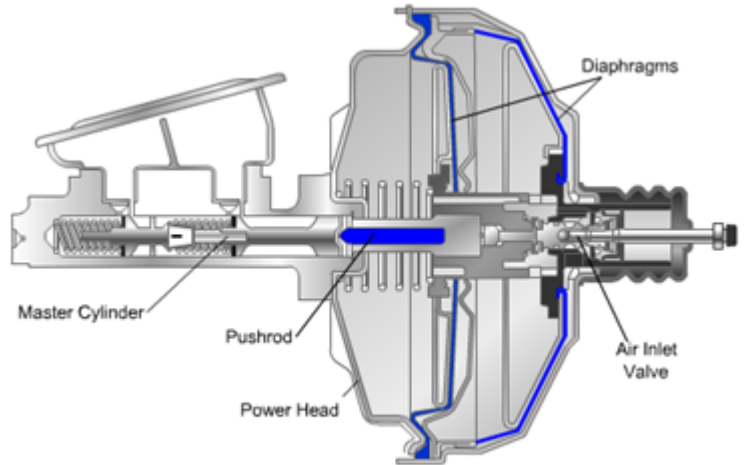

Tandem Diaphragm Booster

Vacuum Booster Operation
 Top: Pedal Normal
 Bottom: Pedal Depressed

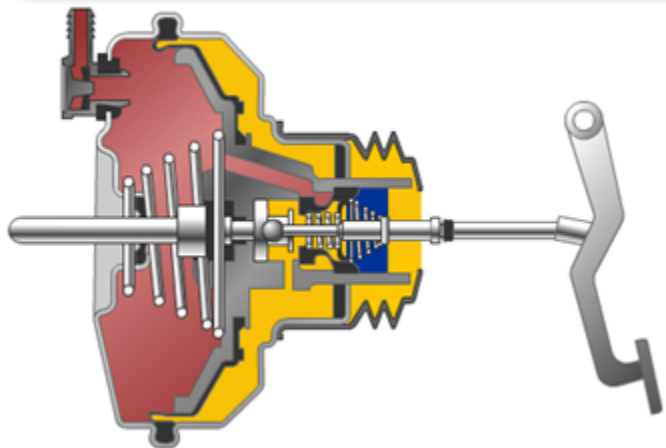
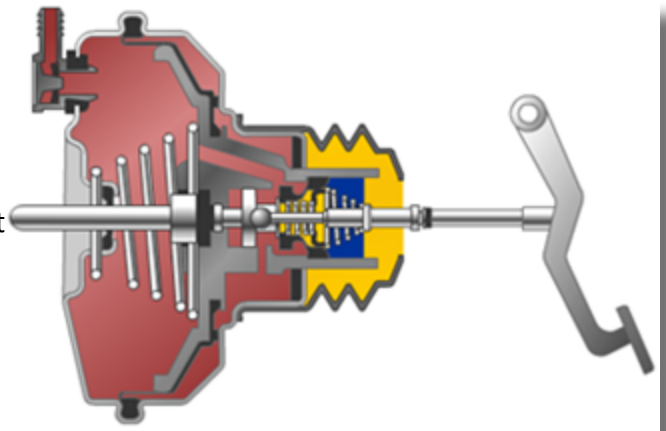

The most common type of Hydraulic-Assist System uses Fluid Pressure from the Power Steering Pump to provide Power Brake Assist. Power Steering Pump Fluid is used to both apply the Brake Assist while driving and also to charge an **Accumulator** (a Nitrogen-Charged Chamber or Spring-Loaded Piston) that holds a supply of fluid under pressure for engine-off assist.

When Hydraulic Pressure fills an Accumulator, it pushes a rubber seal against a piston and collapses the internal spring. If the Power Steering Pump stops (the engine quits) and the Brake Pedal is pressed, the spring will expand and push the fluid into the booster for braking assist. Accumulators can typically provide sufficient (emergency) Hydraulic Pressure for two or three (2 or 3) brake applications if Power Steering Pressure is lost.

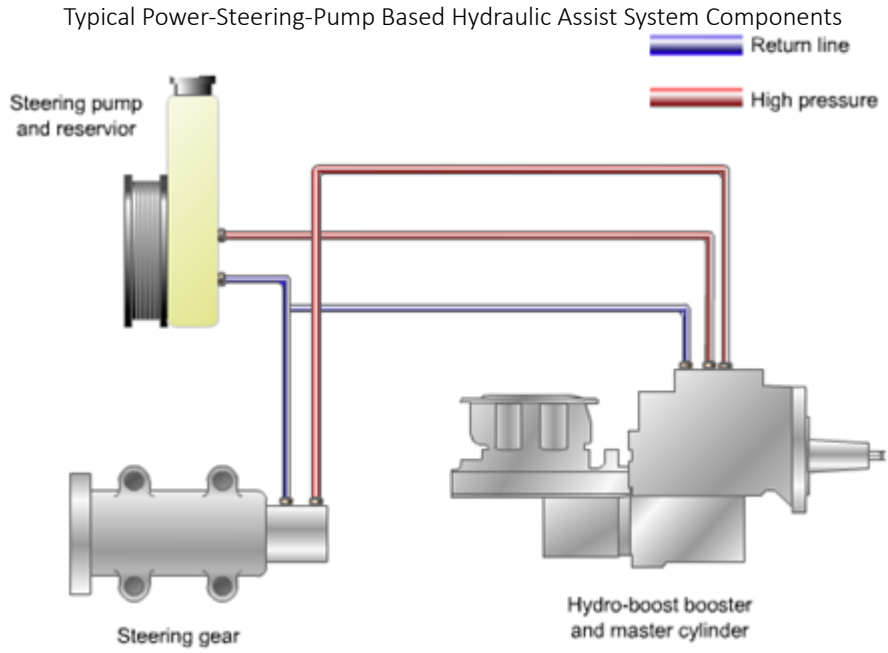

Spring-Loaded Accumulator Hydraulic Assist System

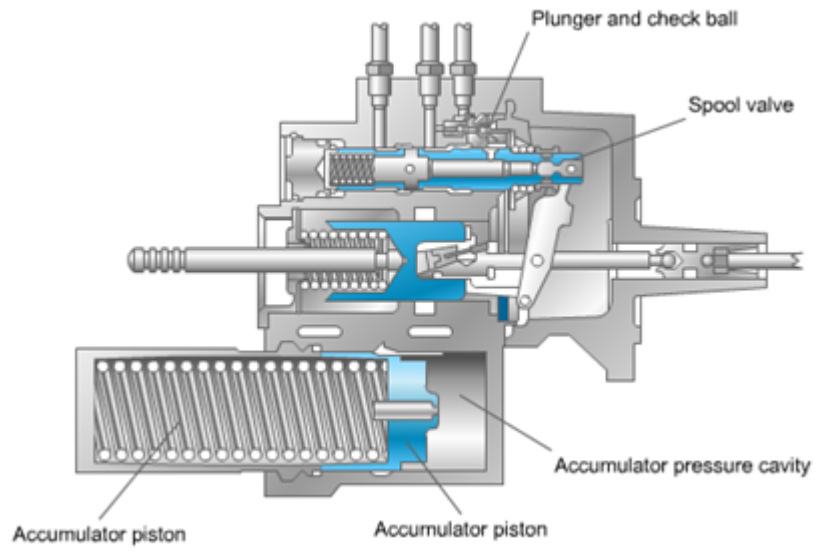

DIAGNOSIS

The procedures that follow are general ones. Always consult the applicable proper service information when diagnosing Power-Assisted Brake Systems.

Keep in mind that many problems can arise that have nothing to do with Power-Assisted Brake Systems. Always check the General Braking system first.

DIAGNOSING VACUUM-ASSIST POWER BRAKE SYSTEMS

Hard Pedal (insufficient boost)

Note: A Hard pedal in Powered-Assist Brake Systems can have the same causes as in Non-Powered Brake Systems. Always check the general Braking System first.

Use a vacuum gauge to measure Manifold Vacuum. The gauge should read at least 15 inches of vacuum when the vehicle is idling. If the reading is low, determine why the engine is losing vacuum and correct the problem.

Make sure the Vacuum Check Valve (located at the vacuum booster) is allowing air to pass from the booster to the manifold while preventing air from traveling from the engine manifold to the booster. Check the valve as follows:

- Remove it from the Booster, with the engine running, to make sure it has vacuum from the manifold.
- If not, remove the Check Valve from the Vacuum Line to see if there is a blocked line from the manifold. Vacuum at the line, but not at the Check Valve, indicates a bad Valve.
- Next, using a Hand Vacuum Pump, pull a vacuum through a hose connected to the Check Valve and Booster. It should hold a vacuum. If it does, press the Brake Pedal to see if the vacuum drops as it should. If a Booster holds a vacuum but it doesn't drop when the Brake Pedal is pressed, the Booster is bad.
- If the Check Valve/Booster test doesn't hold a vacuum, connect the vacuum pump directly to the Booster and pull a vacuum again. If it holds this time, the Booster works and the Check Valve is bad. If it still doesn't hold a vacuum, the Booster is leaking and should be replaced.

PROBLEMS IN THE GENERAL BRAKE SYSTEM

A problem in the general Brake System - not in the Power Assist System - may cause a Brake Pedal to travel completely to the floor.

- Check the Master Cylinder Fluid Level, Hydraulic System, Brake Friction Material, Adjusters, etc.
- Check for air in the Brake Hydraulic System. Bleed the brakes if necessary.

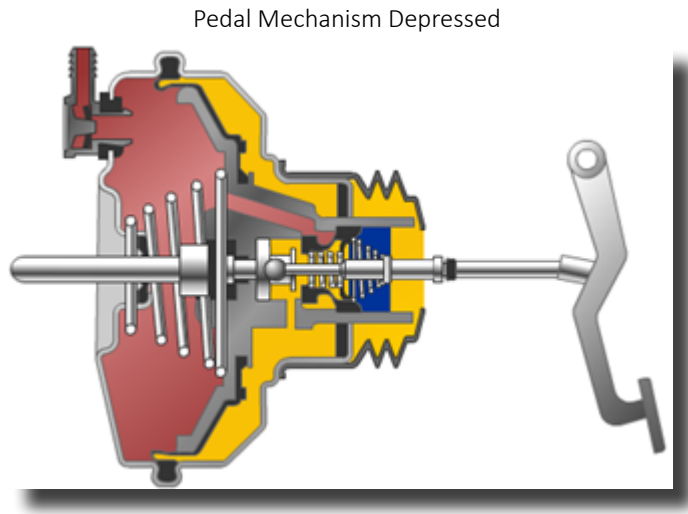

DIAGNOSING HYDRAULIC-ASSIST POWER BRAKE SYSTEMS

Hydraulic Assist Systems tend to fail in one of three ways:

- Power Steering System Problem
- Hydraulic Booster Unit Malfunction
- Accumulator Failure

Regardless of the failure type, the first symptom is most always a Hard Pedal due to the loss of assist.

HARD PEDAL

Note: Hard pedal may develop due to problems unrelated to the Power Assist System. Check the general Braking System first.

- Check for a loose or glazed Power Steering Belt.
- A problem in the Power Steering System can cause trouble in the Power Brake System. Check the Power Steering Fluid Level. Check for kinks or pinches in the Power Steering Pump Hoses. Make sure the Power Steering is functioning properly.
- Check for external leakage in and around the Brake Hydraulic System.
- Check the Power Booster for defects. Repair or replace the Booster as necessary.
- If the Hydraulic Assist System operates correctly with the engine running, but has no assist right after the engine has been turned off, the Accumulator is likely bad.

REPAIRING POWER BOOSTERS

With the exception of Check Valves on Vacuum-Assist systems and Accumulators on Hydraulic-Assist systems, Brake Booster system malfunctions are almost always repaired by replacing the unit.

Hydraulic Booster Components and Arrangement

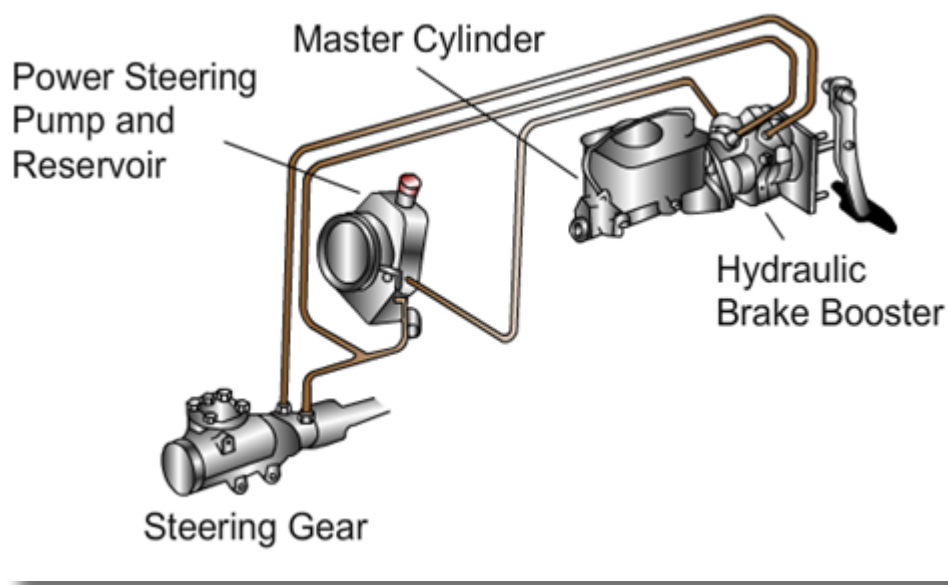

UNIT 6: WHEEL BEARINGS, PARKING BRAKES, BRAKE LIGHTS AND CIRCUITS

The following topics are addressed in this unit:

WHEEL BEARINGS

- Introduction
- Inspecting and Servicing Non-Sealed Wheel Bearings
- Inspecting and Servicing Sealed Bearings
- Inspecting and Replacing Wheel Studs

PARKING BRAKES AND BRAKE LIGHT SYSTEMS

- Introduction
- Parking Brake - Drum System
- Parking Brake - Disc System
- Parking Brake Testing
- Inspecting and Adjusting Drum Parking Brakes
- Inspecting and Adjusting Disc Parking Brakes
- Brake Light Operation and Testing

CHAPTER 1: WHEEL BEARINGS

INTRODUCTION

➔ Wheel Bearing Service

Wheel Bearings are typically serviced any time brake repair work is done, or according to the manufacturer's recommendation.

CAUTION: When lifting a vehicle, always use proper lifting equipment and observe all safety precautions.

Although special tools are available for Wheel Bearing service, such as Wheel Bearing Packers, a torque wrench and common hand tools are typically sufficient.

There are many brands of Wheel Bearing lubricants available on the market, however, inadequate lubricants can break down when exposed to heat, stiffen when exposed to cold, or simply lack the lubricating capability needed for high-speed driving. Always use a high-quality Wheel Bearing Grease, especially those identified as suitable for Disc Brake Systems, as they are usually acceptable for all applications.

Tapered Wheel Bearing with its Race



Serviceable Wheel Bearings typically have scheduled service intervals ranging from 20,000 miles to 30,000 miles under normal driving conditions.

NON-SEALED BEARINGS

Note: Before attempting to service a Wheel Bearing, determine whether the bearing is Sealed or Non-Sealed. Consult the procedures in the applicable service information for information on inspecting and replacing the specific bearing.

INSPECTING NON-SEALED WHEEL BEARINGS

With the vehicle lifted, spin the wheel. It should turn freely without binding or making any noise.

Grasp the wheel by the top and bottom (12 o'clock and 6 o'clock positions) of the tire and try to rock the ends in and out. The wheel should move slightly (.001 inch to .005 inch if measured by a Dial Caliper on the Drum or Rotor).

If spinning the wheel and rocking the tire reveals no problems, then no other inspection is required. However, if the bearings are not noisy, but are slightly loose, then tightening may be needed. If the bearings are noisy, excessively loose, or tight, then the bearings need servicing.

SERVICING NON-SEALED WHEEL BEARINGS

Remove the wheel.

Properly clean the Brake Assembly and remove all of the brake dust.

Remove the Brake Caliper or Drum. If it is not necessary to service the Caliper or Brakes at this time, leave the hydraulic hose connected. Make certain, however, to avoid letting the Caliper hang on this hose.

Find and remove the Dust Cap in the center of the Hub Assembly

Note: If a Dust Cap is not present, the Wheel Bearings are not adjustable.

Remove the Cotter Pin from the Nut Lock.

Remove the Spindle (Adjusting) Nut. Remove the Thrust Washer and the Outer Wheel Bearing from the center of the wheel.

Tapered Wheel Bearing with its Race



CAUTION: Do not drop the bearing as that can damage its 'cage'.

Slide the Hub Assembly off the Spindle.

CAUTION: Do not place your fingers on the Friction Surface of the Disc Pads to avoid getting grease or oil on them. Oil and grease can adversely affect their braking ability. Also do not allow the Hub Assembly to drag heavily across the Spindle threads and damage them.

Disc Brake Bearing Components Disassembled

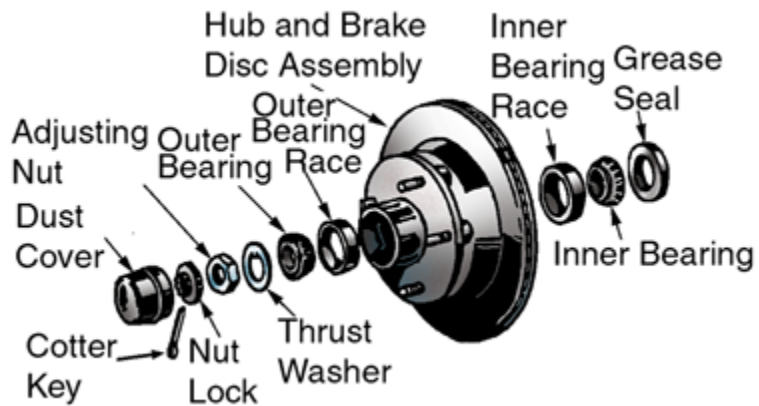

Using a brass drift punch and a small hammer, reach through the hub and tap the inner Grease Seal out of the hub.

Remove the Inner Wheel Bearing.

Using a clean shop towel, wipe the grease out of the hub. Again, avoid getting grease on the Friction Surfaces of the Disc Pads.

Note: If the Rotor is a two-piece design, work on the hubs with the friction disc (Rotor Surface) removed.

CAUTION: Keep all Wheel Bearings in sets and return them to the same spindle they were taken from. Never replace bad Wheel Bearings with used Wheel Bearings.

Thoroughly wash the Wheel Bearings, and all of the parts removed with them, in a proper solvent.

- Make sure to remove all grease from the inside of the bearings.
- Rewash and dry the bearings and accompanying parts.

CAUTION: You can use compressed air to dry the bearings, but do not allow the bearings to spin on your finger while blowing them dry; doing so can damage the bearings, or result in personal injury.

Examine each bearing carefully and note any imperfections such as chips, pits, scratches, etc. Also examine bearings for discoloration, which indicates overheating. If any of these problems are found, replace the bearings.

Note: Always replace each bearing, and its race, if there is any doubt about its condition. Never place a new bearing in an old race or put an old bearing in a new race. They should always be replaced as a pair.

Repack each bearing with fresh, High Temperature grease by manually pushing it into the larger side of the Bearing Assembly until it is forced out of the other, smaller side of the bearing.

Note: Make sure the bearings are repacked with a grease that is designed to withstand the high temperatures and extreme pressures to which the bearings are exposed.

Place the equivalent of 3 to 4 tablespoons of grease on the Bearing Race in the back side of the hub.

Install the Inner Wheel Bearing and a new Grease Seal.

Carefully slide the Hub Assembly onto the Spindle.

Place grease on the Bearing Race in the front side of the hub the same way it was done on the back side. Install the Outer Wheel Bearing, Thrust Washer, and Spindle (Adjusting) Nut.

CAUTION: If solvent or grease gets on the Drum or Disc Friction Surface, clean the surfaces with an acceptable brake cleaning solvent.

Adjust the bearing according to the service information procedure.

Note: DO NOT pack the Dust Cap full of grease. The old story that as the wheel rotates, it will somehow 'draw' grease out of the cap to lubricate the bearings is FALSE. Don't do it.

Reassemble the remaining Brake and Wheel Assembly components.

SEALED BEARINGS

INSPECTING SEALED WHEEL BEARINGS

With the vehicle properly lifted, spin the wheel. It should turn freely without binding or making any noise.

Grasp the wheel by the top and bottom (12 o'clock and 6 o'clock positions) of the tire and try to rock the ends in and out. The wheel should move slightly (.001 inch to .005 inch if measured by a Dial Caliper on the Drum or Rotor).

If spinning the wheel and rocking the tire reveals no problems, then no other inspection is required. However, if the bearings are not noisy, but are excessively loose or tight, then it is probably necessary to replace the bearing.



REMOVING AND REPLACING SEALED WHEEL BEARINGS

Procedures for removing and replacing sealed Wheel Bearings vary greatly but most of them require that the bearings be 'pressed' (using a Hydraulic Press) in and out. Refer to the applicable service information for the procedure that applies to the vehicle to be serviced.

Note: Some Front-Wheel-Drive (FWD) vehicles may have Wheel Bearings that are incorporated into the knuckles. This design requires removing the drive axles and bearings from the knuckle.

Note: Most sealed Wheel Bearings are Non-Adjustable.

TIGHTENING SEALED WHEEL BEARINGS

Note: Sealed bearings are tightened, not adjusted. Most Four-Wheel-Drive (4WD) or Front-Wheel-Drive (FWD) vehicles have sealed bearings.

If a Sealed Bearing makes noise, or does not turn smoothly, disassemble the entire unit to evaluate the bearings, and replace them as needed.

If it is necessary to replace sealed bearings, tighten the new bearings according to the manufacturer's specifications as procedures vary from vehicle to vehicle.

Note: Some Chrysler, and foreign Front-Wheel-Drive (FWD) vehicles, use bearings that cannot be adjusted even though they are not sealed. If these bearings make noise, or fail to turn smoothly, disassemble the entire unit to evaluate and pack the bearings.

WHEEL STUDS

INSPECTING AND REPLACING WHEEL STUDS

Inspect the Wheel Studs.

- Raise the vehicle and remove the Lug Nuts.
- Inspect each Wheel Stud looking for signs of wear or damage. Check for bent or loose studs.

CAUTION: For safety reasons, all damaged or worn studs should be replaced.

Damaged Wheel Studs



Damaged Wheel Studs



REPLACING DAMAGED WHEEL STUDS

Note: Because of variations in vehicle designs, there are a number of different service procedures used to replace Wheel Studs. The following is a general procedure. Be sure to locate the correct procedure for the vehicle.

- Remove the Lug Nuts and Wheel.
- Remove the Brake Rotor/Drum and Hub Assembly.

Note: On some vehicles, it is not possible to remove the hub.

- Use a Press to force the damaged studs out of the Hub Assembly.
- Inspect the stud-mounting area of the hub for damage or wear.
- Insert the new studs and use a Press to force them to set. A hammer is not an acceptable replacement for a proper Press as it may damage the Drum or Rotor.
- Reinstall the Hub Assembly, Brake Rotor/Drum, and Wheel.
- Install and torque the Lug Nuts to specifications.

Replacement Wheel Stud



CHAPTER 2: PARKING BRAKES & BRAKE LIGHT SYSTEMS

INTRODUCTION

PARKING BRAKE

Automotive Parking Brakes are designed to hold a vehicle stationary (keep it from rolling) when not in use. Most of them operate by using either a hand or foot-operated lever, and cables, to mechanically apply the Rear-Wheel Brakes.

Federal Motor Vehicle Safety Standards require that Automotive Parking Brakes be capable of holding a vehicle stationary on a 30 degree grade.

Parking Brakes also must operate independently of the Hydraulic Service Brakes.

In typical Parking Brake systems, when the Lever or Foot Pedal is activated, the cables to the Rear Brakes pull and hold those Brakes against their friction surfaces. Other systems use Electric Actuators, rather than mechanical action, to apply the Parking Brakes.

To release a Parking Brake, either the driver manually releases the Lever or Pedal, a Vacuum Motor releases it when the Transmission shifts out of Park, or an Electric Actuator rotates to release the Rear Brakes.

PARKING BRAKE SYSTEM COMPONENTS

Various Cables, Levers, Struts, and Linkages connect the Parking Brake system to either a Hand-Operated Lever or Foot-Operated Pedal.

This image shows the activating cables that go to each rear brake as well as the Latch/Release mechanism. A Latch/Release Unit has the 'catch' that holds the Parking Brakes in the applied position, as well as the lever that releases that catch.

Typical Parking Brake System

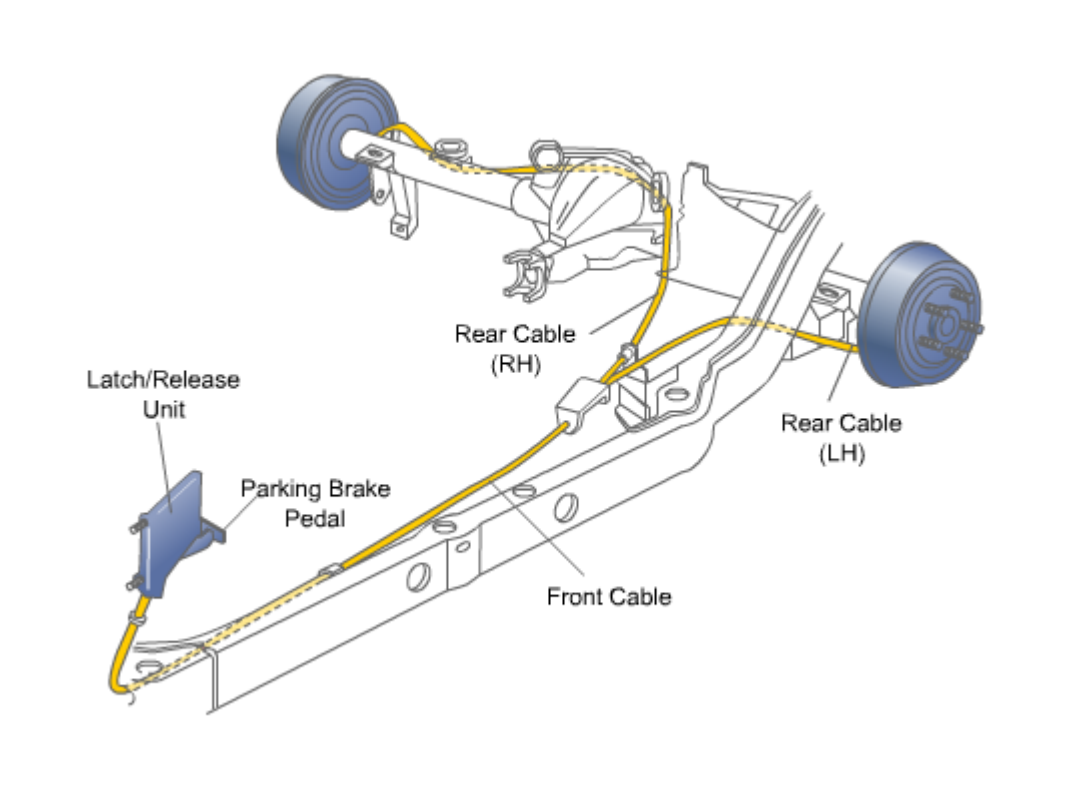

Additional Parking Brake components are connected to the Service Brakes and will be seen in the next sections.

Parking Brake Cable Routing to Rear Brake



Parking Brake Cable Connection to Rear Brake



DUM PARKING BRAKE

PARKING BRAKE - DRUM (DUO-SERVO)

When a driver applies the Parking Brake on a vehicle equipped with Rear Drum Brakes, it pulls cables that are attached to Parking Brake Levers and struts inside the Brake Assembly. These levers and struts mechanically apply the brakes by pushing both Brake Shoes outward against the Drum.

When the Parking Brake releases, a spring on the Parking Brake Strut re-centers the shoes in the Drum.

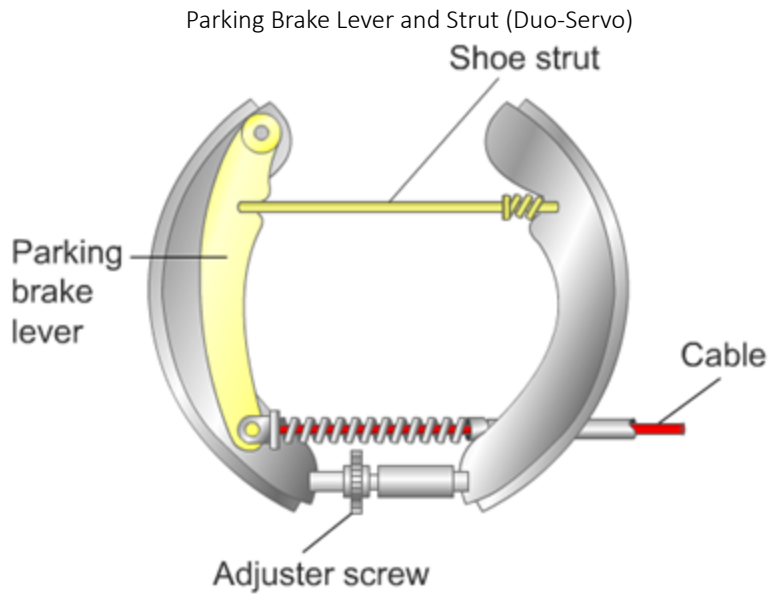

DISC PARKING BRAKE

DISC BRAKES WITH INTEGRAL PARKING BRAKE

Many vehicles that are equipped with Rear Disc Brakes require a regular application of the Parking Brake to keep the Rear Disc **Service** Brakes in proper adjustment. Unlike Front Disc Brakes, Rear Disc Brakes on these vehicles are not Self-Adjusting.

The two most common types of Caliper-Actuated Parking Brakes are the:

- Screw-and-Nut
- Ball-and-Ramp

Parking Brake Operation
Operation of Parking Brake

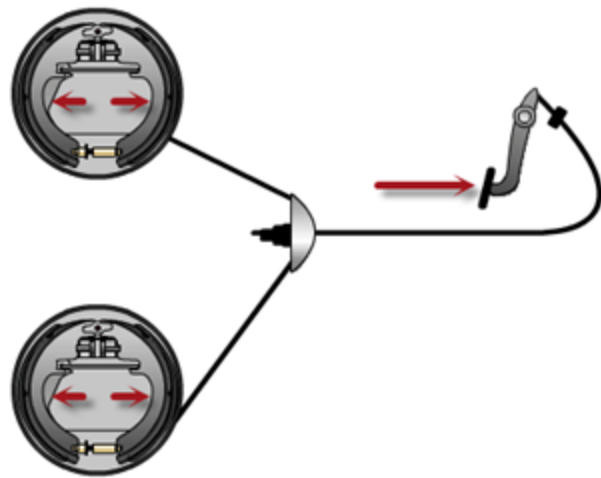

SCREW AND NUT PARKING BRAKE

When the Parking Brake is applied on a Rear-Disc-Equipped vehicle with a Screw-and-Nut system, the following occurs:

- The Cable Actuated Parking Brake Lever rotates an Actuator Screw.
- The Actuator Screw unthreads on a Nut inside the Piston.
- As the Screw turns, it moves the Nut outward by pressing against a Cone inside the Piston.
- The Piston applies the Inboard Pad against the Rotor. The movement of the Piston also causes the Caliper assembly to slide and apply the Outboard Pad.

- An Adjuster Spring inside the Nut and Cone rotates the Nut outward when the Parking Brakes are released to provide self-adjustment. Rotation of the Nut also takes up clearance as the Brake Pads wear.

A GM Screw-and-Nut Parking Brake Mechanism

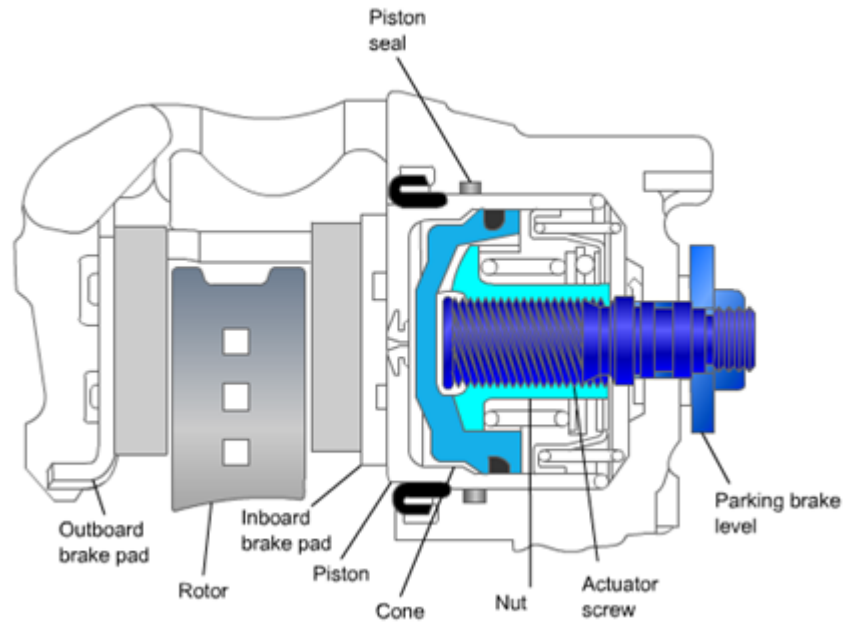

BALL-AND-RAMP PARKING BRAKE

In a Ball-and-Ramp Parking Brake system, a Caliper (or Operating) Lever is attached to a shaft inside the Caliper that has a small plate on the other end. A second plate is attached to a Thrust Screw inside the Caliper Piston. Three steel balls separate the two plates. When the Parking Brake is applied, the Caliper Lever rotates the Shaft and Plate. Ramps on the surface of the plate force the balls outward against similar ramps in the other plate. This action forces the Thrust Screw and Piston outward applying the Brake. When the Parking Brake is released, an Adjuster Nut inside the Piston rotates on the Thrust Screw to take up excessive clearance and provide Self-Adjustment.

A Ford Ball-and-Ramp Parking Brake Mechanism

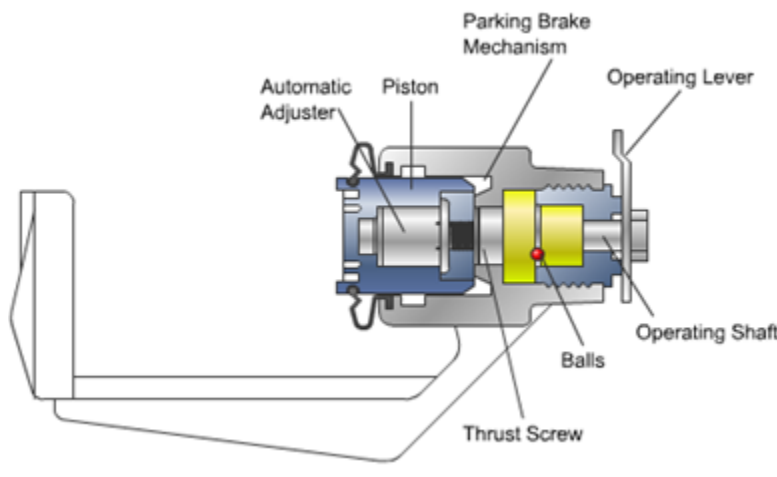

DRUM-IN-HAT PARKING BRAKE

Some later model vehicles with Four-Wheel Disc Brakes have a Parking Brake system that uses a small Drum Brake, incorporated into the Rear Rotor, called a Drum-in-Hat system. This system consists of a simple, Cable-Activated Shoe Assembly that applies against a Drum machined into the Rotor Hat section. In essence, it operates like a miniature Leading-Trailing Brake System. With a Drum-in-Hat Parking Brake system, the Rear Caliper does not have to perform both Service and Parking Brake functions. That means that the Rear Disc Brakes are Self-Adjusting just like the Front Disc Brakes. In addition, the Parking Brake Shoes for this system are manually adjusted when installed and, theoretically, should never need readjustment.

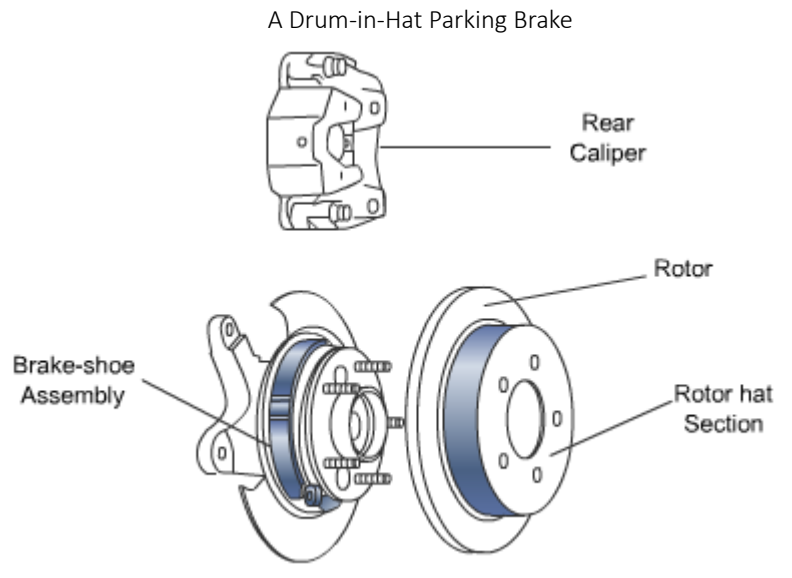

Note: Kinked or binding Parking Brake Cables or Linkages could prevent a Parking Brake from applying or releasing properly. This could also cause the Brake Warning Light to remain on even after the Parking Brake is released.

TESTING

TESTING PARKING BRAKE PERFORMANCE

- Place the vehicle on a slope with the front of the vehicle pointed downhill.
- Set the Parking Brake, place the Transmission in Neutral, and slowly release the Hydraulic Brakes. The Parking Brake should hold the vehicle. If it doesn't, servicing is required.
- Turn the vehicle around with the front pointing uphill.
- Set the Parking Brake, place the Transmission in Neutral, and slowly release the Hydraulic Brakes. The Parking Brake should again hold the vehicle. If it doesn't, servicing is required.

DRUM ADJUSTMENT

➤ Inspecting and Adjusting Drum Parking Brakes

INSPECTING DRUM PARKING BRAKES

Check under the vehicle to ensure that the Cables and Linkages work freely and are in good physical condition. Check the cables especially closely for fraying.

Remove the Brake Drum to make sure that all of the Parking Brake components are assembled correctly, that the Parking Lever and Strut operate properly, and that they exhibit no signs of excessive wear.

Parking Brake Adjusting (Equalizer) Screw and Nut



Inspect the activating components of the Parking Brake, as well as the Friction Surfaces of each Brake Shoe, for thickness and contamination. Repair any components as needed.

ADJUSTING A DRUM PARKING BRAKE SYSTEM

Make sure the Parking Brake is OFF. If necessary, adjust the Brake Shoes to make sure there is no brake drag (resting clearance or adjustment is correct).

Engage the Parking Brake Lever, or Pedal, two notches.

Use proper lifting equipment, and safe procedure, to raise the vehicle.

CAUTION: When lifting a vehicle, always use proper lifting equipment and observe all safety precautions.

Reduce or increase the slack in the Parking Brake Cables, using the Equalizer Nut, to move the Equalizer up or down the Adjustment Rod.

Turn the Equalizer Nut one turn at a time to increase or reduce cable slack. After each turn of the Nut, spin the Rear Wheels.

When the Parking Brake is adjusted correctly, there will be a slight drag on the Rear Brake. After feeling the slight Brake drag, release the Parking Brake Lever or Pedal.

The final test that the adjustment is correct is to make sure the wheels spin freely with the Parking Brake released.

DISK ADJUSTMENT

↻ Inspecting and Adjusting Disc Parking Brakes

INTEGRAL DISC PARKING BRAKES

Note: Because the activating device for an Integral system is located inside the Caliper, inspection can occur only if the Caliper is disassembled. To inspect the activators in these systems, consult the applicable service information.

Completely disengage the Parking Brake and raise the vehicle.

Visually inspect the thickness of the Friction Material on the Disc Pads by looking through the Caliper. Replace if worn out or damaged.

Make sure the Cable Levers on the Calipers are on their OFF Stops.

Manually rotate the Parking Brake Levers on the back of the Calipers (if possible), while turning the Rotor, to verify that they are working and not 'frozen'. If the Brakes do not stop the Rotor when the Lever is rotated, the internal mechanism is not working.

Adjust the cable length at the Equalizer.

When the adjustment is correct, it should take about 3 clicks of the Lever or Pedal to apply the Parking Brake.

As with the Drum Brakes, the final test that the adjustment is correct is to make sure the wheels spin freely with the Parking Brake released.

Auxiliary Drum (Drum-in-Hat) Parking Brake

- Remove the Rotor/Drum from the Rear Axle.
- Inspect the Activating Components of the Parking Brake.
- Check the Friction Surfaces of each Brake Shoe for thickness and contamination.
- Repair the components as necessary.

If necessary, adjust the Parking Brake Cable until 3 clicks of the Parking Brake Pedal will hold the vehicle on the 30 degree grade. Also verify that there is no dragging of the Parking Brake Shoes when the Pedal is released.

BRAKE LIGHTS

↻ Brake Lights and Circuits

TESTING THE PARKING BRAKE INDICATOR LIGHT

- Turn the Ignition Switch to the RUN position.
- Observe the Indicator Light while setting and releasing the Parking Brake. Note whether the Light goes ON when the Brake is applied and OFF when the Brake is released.

Brake Indicator Light

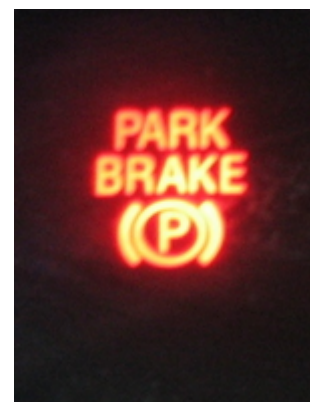

TESTING THE BRAKE LIGHT CIRCUIT

Brake Lights illuminate when the Brakes are applied, thus warning other drivers that the vehicle is slowing down or stopping.

A Switch, usually located at the Brake Pedal, controls the Brake Light circuit. Sometimes a Brake Light Switch is hydraulically activated when a Brake System is pressurized, such as in Hydro-Boost or Integral ABS systems.

Brake Lights are always at the rear of the vehicle and could be as few as two or as many as seven separate Lights. On all newer vehicles, a single 'third' Brake Light, sometimes called a Center High Mount Stop Lamp (CHMSL) is mounted high and in the center of the vehicle. The CHMSL Brake Light is often mounted inside the vehicle and shines out through the rear window.

Rear Brake Light circuits are supplied full time Battery Power (12 Volts), even when the Ignition Switch is OFF. That guarantees that they can work in case of an emergency, regardless of whether or not the key is turned to ON.

TESTING THE BRAKE LIGHTS

To test a Brake Light Switch, have an assistant depress the Brake Pedal and observe the Brake Lights at the rear of the vehicle. If all the Lights come on, the switch is operating normally.

If some of the Lights are on and some are not, check the bulbs on the Lights that are not functioning.

If all the Lights on one side are inoperative, check the Directional Signal switch on the inoperative side.

If the Brake Lights are not functioning, even though the bulbs are operational, inspect the Brake Light Switch using the following procedure.

- Locate the Brake Light Switch, near the Brake Pedal, and unplug the connector. Attach a jumper wire between the plug's terminals.
- If the Light comes on, replace the Switch.
- If the Light still does not come on, look for faults in the Brake Light wiring.

Brake Indicator Lights on Dashboard



TESTING THE BRAKE STOP LIGHT SYSTEM

If the diagnostic procedure in the previous section did not fix the Brake Light problem, continue the process using the applicable service information and wiring diagram. First, test the fuses related to the Brake Light system and replace any that are blown.

Note: if one or more fuses are blown, replacing the fuse(s) may or may not correct the concern.

Test the Brake Light switch for Battery Power (12 Volt) to the switch, and Power out of the switch, with the Brake Pedal depressed. If there is Power to the switch but no Power out, with the Pedal depressed, the switch may be defective and should be replaced.

If, when the Brake Pedal is depressed, some of the Brake Lights come ON but others do not, there is a problem with some of the bulbs, or part of the Brake Light circuit. Check next for Power and Ground to the bulbs.



UNIT 7: ABS AND TRACTION AND STABILITY CONTROL SYSTEMS

The following topics are addressed in this unit:

SYSTEMS AND COMPONENTS

- Introduction
- Antilock Brake System Components
- Antilock Brake System Designs
- Traction Control System
- Stability Control System

ANTILOCK BRAKE SYSTEM DIAGNOSIS AND SERVICE

- Normal Operation and Precautions
- System Diagnosis
- Intermittent Problems Diagnosis
- Servicing ABS Components
- Regenerative Braking

CHAPTER 1: SYSTEMS AND COMPONENTS

INTRODUCTION

➤ Introduction to Antilock Brake Systems (ABS)

Antilock Brake Systems (ABS) are designed to help a driver maintain control of a vehicle during Panic Braking. If a vehicle's wheels are allowed to lock up during braking, it can skid and cause a loss of control. The reason for this is that a tire that is skidding (locked up) cannot steer. Only a rolling tire actually has enough 'directional traction' to steer a vehicle. Therefore, ABS prevents the Brakes from being applied hard enough to lock the wheels, in order to maintain steering.

BRAKING EXAMPLES WITH AND WITHOUT ABS

In an ABS-equipped vehicle, electronic sensors detect if one or more of the individual wheels are approaching lock up. If a wheel, or wheels, gets close enough to lock up, and the Brake Pedal is applied, the ABS unit can modify brake application at the individual wheels at a rate up to 15 times per second to prevent the lock up.

Note: For an ABS system to activate, it must have both the Sensor Signals and the Brake Pedal application. If there is no Brake Pedal signal (eg. bad Brake Switch) the ABS system will not work regardless of whether the wheels lock up or not.

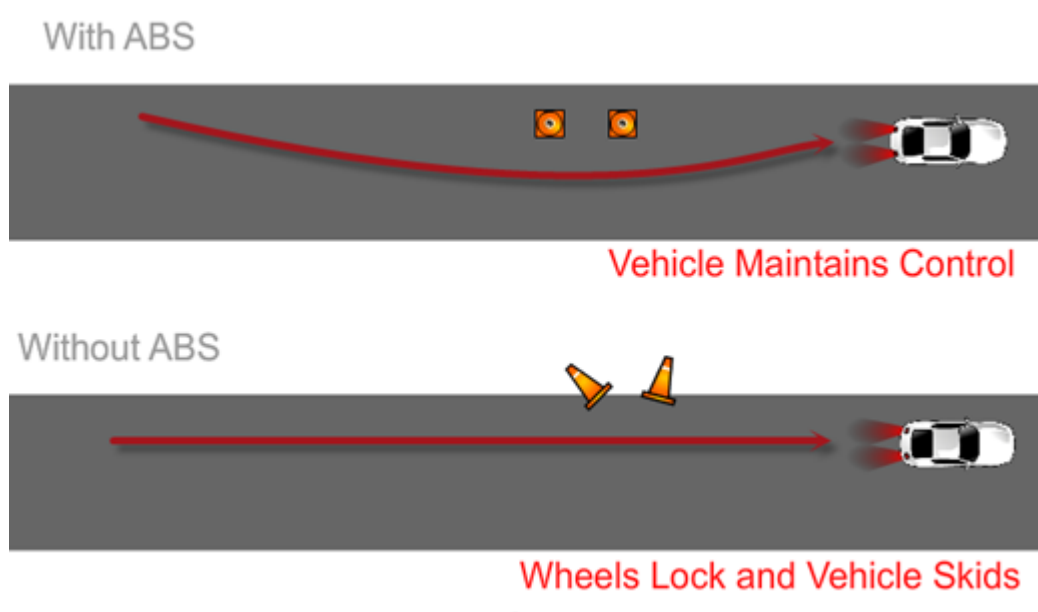

ABS is not designed to maintain vehicle control during hydroplaning or radical steering maneuvers. During **hydroplaning**, a vehicle's tires ride on a film of water that separates them from the road surface. As such, hydroplaning can cause a loss of control which Antilock Brakes cannot correct. Antilock Brakes are also not intended to prevent or correct skids that result from radical steering maneuvers or high-speed cornering.

LOSS OF ROAD CONTACT DUE TO HYDROPLANING

To call ABS a Braking System is actually a misnomer, which means that its name is not really accurate. Even though Antilock Brake Systems use Wheel Speed Sensors, and Brake Pedal Switches, and control the pressure to the individual brakes, ABS is actually a **Steering System**. This is due to the fact that its function is to maintain Steering Control and not to stop the vehicle. Also, even though ABS will typically help a vehicle to stop faster, and in less distance, in some instances it can actually increase the stopping distance.

Note: ABS is a Steering System rather than a Braking System.

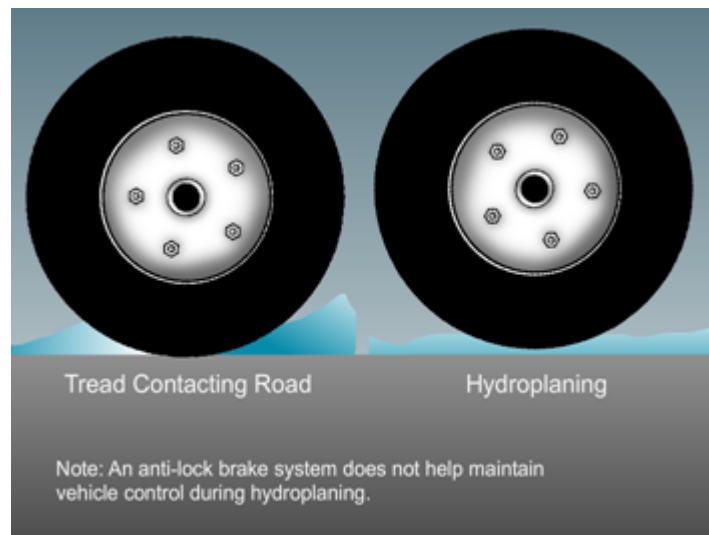

Some Antilock Systems also include Traction Control and/or Vehicle Stability Control.

- Traction Control Systems can rapidly apply and release a vehicle's Brakes to reduce wheel spin and add traction during rapid acceleration.
- Vehicle Stability Control Systems automatically and selectively apply the Brakes as needed to help keep the vehicle on its intended course and avoid skidding.

ABS COMPONENTS

➤ Antilock Brake System Components

Antilock Brake Systems use all of the components in a conventional Hydraulic Braking System such as the Brake Booster, Master Cylinder, Brake Lines/Hoses, Wheel Cylinder/Calipers, Brake Drums/Rotors, and Brake Pads/Shoes.

In addition, the other components required for ABS to function include a Brake Pedal Switch, 4 Wheel Speed Sensors (WSS), a Hydraulic Modulator, an Electronic Controller, and an ABS Light on the dash.

Note: Even though ABS systems use all of the components in the Hydraulic Brake System, a failure or shutdown in the ABS system will not cause the Hydraulic Brake System to also shut down.

WHEEL SPEED SENSORS

Wheel Speed Sensors are electromagnetic devices that determine Wheel Speed.

While some older ABS systems used either one or three Speed Sensors, since about Model Year 2000 all vehicles have been equipped with four Wheel Speed Sensors (one for each Wheel).

- A Speed Sensor includes a Toothed Ring and a Magnetic Pickup Coil.
- Toothed Rings are mounted on rotating components.
- Magnetic Pickup Coils are stationary and mounted close to the Rotating Toothed Ring.

As a Toothed Ring rotates, it induces a Voltage in a Pickup coil. As the Wheel Speed increases, so does the rotating speed of the Toothed Ring.

Left: Wheel Speed Sensor and Toothed Ring
Right: Actual Installed Wheel Speed Sensor

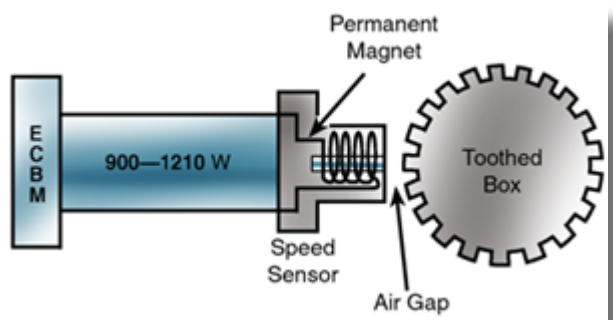
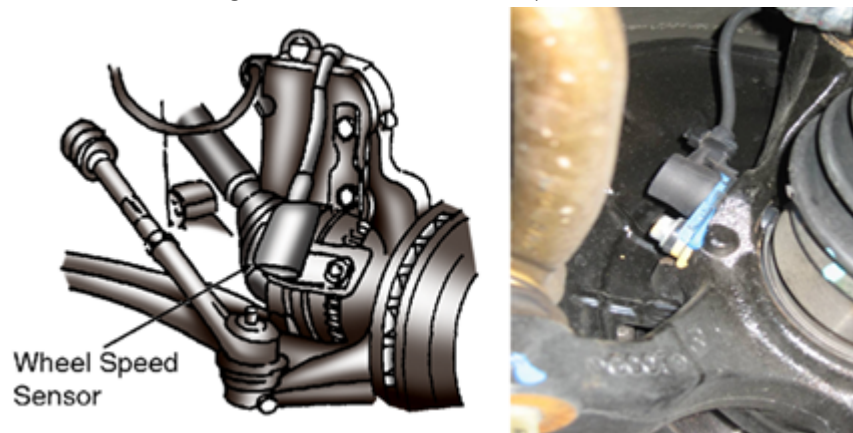

The Voltage produced in the Pickup Coil by the rotating Toothed Ring will be proportional to the speed of the wheel, which means that the faster the Wheel turns, the higher the Voltage will be. This Voltage signal will then be sent to the ABS Controller.

BRAKE MODULATOR

A Brake Modulator, which is activated by the ABS Controller, is the device that prevents Wheel Lockup and/or Skidding by adjusting the amount of Hydraulic Pressure that is supplied to, or removed from, each of the wheels.

Most Brake Modulators have two Control Valves for each Wheel; one that allows the brake to pressurize and one that depressurizes it. Those valves go by a series of different names such as Hold/Release, Inlet/Outlet, Isolation/Dump, and others. For the purposes of this course, we will use the terms Inlet and Outlet.

ABS CONTROLLER

ABS Controller Assembly



Side View



While the Brake Modulator contains the actual mechanical Inlet and Outlet valves, it is the ABS controller that operates the Electric Solenoids that make those valves Open or Close, based on the Wheel Speed Sensor and Brake Pedal inputs.

The **ABS controller** is essentially a microcomputer that receives signals from the Wheel Speed Sensors and Brake Pedal, processes those signals, and decides whether or not to activate any Valve Solenoids. Depending on the Vehicle, Model Year, and Manufacturer, an ABS Controller can have many different names such as ECU, ABS-ECM, ABCM, EBCM, EBTCM, CAB, and others. However, all of them perform essentially the same functions regardless of the name.

Assembly (On Vehicle)



DESIGN VARIATIONS

➤ Antilock Brake System Design Variations

Most Antilock Brake Systems are designed for all four wheels, however, some older systems such as GM's RWAL (Rear Wheel Antilock) and Ford's RABS (Rear Antilock Brake System), were designed only for the Rear Wheels of Trucks. Rear Antilock Systems were used to help compensate for the large difference in Braking efficiency between a loaded Truck and an unloaded Truck. This is due to the fact that an unloaded Truck will tend to 'pitch forward' more during Braking. Although these systems haven't been produced in more than two decades, a large number of them are still on the road in older Trucks.

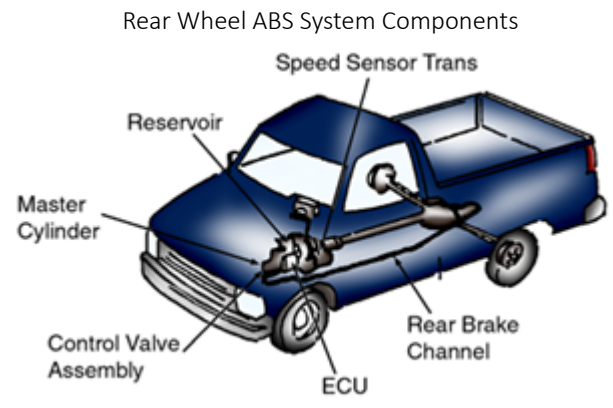

Two-Wheel (Rear Only) ABS systems require the following components:

- ABS Controller
- Wheel Speed Sensor
- Brake Pedal Switch
- Inlet and Outlet Hydraulic Valves

Although the ABS Controller and Brake Pedal Switch for Two-Wheel Systems operate essentially the same as the Four Wheel System described in the previous section; in the Two-Wheel System there is only Wheel Speed Sensor, one Inlet Valve and one Outlet Valve to control both Rear Wheels.

During Hard Brake application (Brake Pedal pressed), if the Controller senses eminent Wheel Lockup (from the Speed Sensor), it will activate the Inlet (HOLD) Valve to limit the pressure to the Rear Brakes. If the Differential Sensor still indicates Lockup, the Controller will activate the Outlet (DUMP) Valve to release Rear Brake Pressure and allow the Rear Wheels to regain 'rolling speed'. The Controller will then turn off both Valves, and recheck the Sensor speed. If it is still trying to Lock Up, the process can be repeated several times per second.

NON-INTEGRATED ABS SYSTEMS

Non-Integrated Antilock Brake Systems, where the ABS components are separate from the general brake components, are used on essentially all new vehicles. Part of the reason for this is that they use a conventional Master Cylinder and Brake Booster. With those components already in place, it is relatively easy to add ABS to a vehicle simply by installing a Controller/Modulator (or ElectroHydraulic) unit to an existing Brake Platform. Separated units also allow car engineers to put the individual components in different places depending on the design of the vehicle.

Non-Integrated ABS Systems use the same Inlet/Outlet Valve control of the Brakes described previously.

OTHER SYSTEM DESIGN CONSIDERATIONS

Some Antilock Brake Systems are tailored to meet specific needs.

Antilock Brake Systems can be either One-, Three- or Four-Channel Systems. Three-Channel Systems control the Front Wheels independently while the Rear Brakes are controlled together on a common circuit. These systems can have a Wheel Speed Sensor at each Wheel (4 total) or one for each Front Wheel and a third Sensor on the Drive Line (3 total) to monitor the Rear Wheels as a pair. Four-channel systems require speed sensors for each wheel and thus control each wheel independently. New vehicles tend to have Four-Channel Systems.

Mounting Locations of Non-Integrated ABS Components



Note: Antilock Brake Systems have built-in diagnostic capabilities in their Controllers/Computers. As such, diagnosis and repair of an ABS System is relatively simple, but does require the applicable service information and Diagnostic Equipment (Scan Tool).

TRACTION CONTROL

➤ Traction Control Systems

Traction Control Systems work with the ABS Controller and Wheel Speed Sensors to reduce wheel spin and add traction during rapid acceleration.

Some traction control systems use separate Hydraulic Valve Units and Control Modules from the ABS while others use the same components.

Common components of a Traction Control System:

- Speed Sensors at the Front and Rear Wheels
- ABS Relays
- TCC/Antilock Brake Switch (Deactivates System)
- Electronic Brake and Traction Control Module (EBTCM)
- Pressure Modulator Valve Assembly
- Light in Dash to Indicate System Operation/Failure

STABILITY CONTROL

➤ Stability Control System Function and Components

Stability Control Systems work with the ABS and Traction Control System to help improve vehicle control, particularly during maneuvering.

The system uses a microcomputer to compare the driver's Intended Path, which is determined by a Steering Wheel Sensor, with the vehicle's Actual Path, based on information from additional sensors.

When the system senses a difference between the vehicle's Intended and Actual Paths, it applies the brakes to the specific wheels needed to bring the vehicle back on course.

Common components of a Vehicle Stability Control System:

- Microcomputer to process information from the system's sensors
- Steering Angle Sensor to determine Steering Wheel Position
- Wheel Speed Sensors located at each wheel
- Yaw Sensor to determine the vehicle's movement around its vertical axis
- Lateral Acceleration Sensor to determine side-to-side movement

CHAPTER 2: ANTILOCK BRAKE SYSTEM DIAGNOSIS AND SERVICE

NORMAL OPERATION AND PRECAUTIONS

CHARACTERISTICS OF ANTILOCK BRAKING SYSTEMS

In general, the Pads, Shoes, Drums, Rotors, Mounting Hardware, and Bearings on Antilock Brake Systems (ABS) are serviced in the same manner as on conventional Brake Systems.

Many ABS problems are caused by Speed Sensor air gaps that are out of specification or electrical connections that are loose or corroded.

RECOGNIZING NORMAL ABS FUNCTIONS

Some ABS functions may seem like problems when they are actually a part of normal operation.

Noises

Many ABS-equipped vehicles will perform a Diagnostic Self-Test after the vehicle has been started and has reached a designated speed (3-5 MPH). Diagnostic Self-Tests activate only on the first acceleration after engine start, not on every acceleration. The Self-Test can produce a short series of Clicking, Popping, Groaning, Whirring, or Growling sounds. These noises are the sounds of the Antilock System cycling the Inlet/Outlet Valves and running the Hydraulic Pump. These same noises may also be produced, and heard, during Antilock Stops.

Brake Pedal Pulsation due to ABS operation is much faster (up to 15 times per second) than Pulsation due to bad Rotors or Drums. Students should familiarize themselves with the difference.

Mounting Locations of Non-Integrated ABS Components



Note: Often times when a driver makes a panicked ABS Stop, the Pulsation of the Brake Pedal scares them and they release the Pedal, possibly causing an accident. The proper way to use ABS Brakes is to hold the Pedal, even when the Pulsations start, until the vehicle stops, since releasing it will deactivate ABS. Practice with ABS Stops is good training for both technicians and non-technicians.

Pedal drop

On some systems, the Brake Pedal may drop slightly during Antilock Braking. This 'drop' occurs as the Accumulator relieves Hydraulic Pressure by temporarily taking fluid out of the Hydraulic System. As with Pedal Pulsation, the proper procedure is to hold the pedal, and don't try to 'pump it', until the vehicle has stopped.

PRECAUTIONS FOR SERVICING ANTILOCK BRAKE SYSTEMS

CAUTION: Failure to observe these precautions may result in personal injury and/or damage to the system. The following are general precautions and the applicable service information should always be used when servicing Antilock Brake Systems.

Antilock Systems operate at very high pressures. Always depressurize the system before servicing any ABS unit.

Most ABS components are not serviceable; replace them as an assembly. Do not disassemble any ABS component that is not designed to be serviced.

Follow the correct Service Information carefully. Using an incorrect sequence of steps, skipping steps, or using the wrong service information can lead to the unnecessary replacement of parts.

Before Test Driving a vehicle with an ABS problem, apply the brakes at a lower speed to be sure the car stops normally.

Use the manufacturer's specific procedure for Bleeding the Brakes on ABS-Equipped Vehicles as procedures can vary greatly from system to system.

DIAGNOSIS

➤ Diagnosing Antilock Brake Systems

Note: Procedures for diagnosing problems in Antilock Systems vary greatly depending on the specific system. Although some systems may appear identical, use only the Diagnostic and Service Procedures that the manufacturer of the system recommends.



Always begin the Diagnosis of an Antilock Brake System with a thorough Visual Inspection of the entire system.

- Check the Brake Fluid Level.
- Check the system fuse(s).
- Check all of the system's electrical connections. Make sure the Ground connections are tight and corrosion free and the hydraulic lines and connections are in good condition. Check any Diodes in the system's wiring harnesses. Refer to the applicable service information for the test procedures and location of the Diodes.

If the Visual Inspection reveals no problems, consult the service information for rest of the Diagnostic Procedure.

Service on most Antilock Systems requires the use of Special Tools, such as a High-Impedance DMM, a set of Pressure Gauges, a Scan Tool with updated software, a Digital Storage Oscilloscope (DSO) or Graphing Multimeter (GMM), and possibly a Breakout Box.

A High-Impedance DMM must be used because a conventional Multimeter can affect circuit operation or damage components.

CAUTION: Some components should not be tested directly, even with a high-impedance DMM. Use only the Diagnostic Equipment and Service Procedures that are appropriate for the make and model of vehicle being serviced.

DSOs and GMMs Graph changes in Voltage over Time using a Waveform. Since both devices provide a continuous readout over a period of time, either of them can show abrupt changes or intermittent problems in the signals that other Diagnostic Equipment might miss.

Tools for ABS/TCS Diagnostics



For most systems, it is possible to directly access the Diagnostic Trouble Codes (DTCs), stored in the ABS Computer, with a Scan Tool. For some older systems, Trouble Codes, or Flash Codes can be read in the form of Flashes from the system Warning Light. Most service information provides flowcharts to help identify the system problems precisely based on those Codes or on Symptoms.

INTERMITTENT PROBLEMS

➤ Diagnosing Intermittent Electrical Problems

Note: Standard Diagnostic Procedures may not always help to determine the cause of Intermittent Electrical Problems in an Antilock System. In most cases the fault must be present for a certain amount of time to set a DTC, or locate the problem using a Diagnostic Symptom Chart. Intermittent problems, as the result of faulty electrical connections or wiring, are not always present long enough to set a code or cause an Operating Symptom.

As a precaution, make sure all Connector Halves are properly mated, and that the terminals are fully seated in the Connector Body.

Check for improperly formed or damaged terminals.

Look for poor terminal-to-wire connections. If necessary, remove the terminal from the connector Body to inspect it.

If a Visual Check does not locate the cause of the problem, test drive the vehicle to try and duplicate the condition.

CAUTION: Always obtain permission from your Instructor before road testing a vehicle, and check for adequate braking capability before moving any vehicle.

SERVICING COMPONENTS

➤ Servicing ABS Components

SERVICING SPEED SENSORS

Visually inspect the Speed Sensors. Check the Toothed Rings (if possible, some are sealed) for missing or broken teeth. A Toothed Ring should show no evidence of contact with the Wheel Speed Sensor. If there has been contact, determine the cause and correct it.

If available, an Oscilloscope is useful for evaluating Wheel Speed Sensor Signals by connecting to the sensor, and turning the wheel by hand.

Note: If the WSS cables are not correctly installed in their retainers, they may contact moving parts and/or become overextended. This situation can create a system failure. In addition, if the sensor cables are routed incorrectly, other conductors positioned closely to the sensor cables may induce false voltage signals.

Wheel Speed Sensor



For an Antilock System to function correctly, a vehicle's Tires and Wheels must be of the proper Size and Type. Use only the Tire Size that the manufacturer recommends and insure that all four tires are the same size, unless the vehicle is designed for different Front/Rear Tire Sizes. Proper Tire Size is important because Antilock Systems operate according to Wheel Speed Signals and incorrect Tire Sizes will send incorrect Speed Signals to the Controller.

In the same way, tires must be maintained at the correct Air Pressure, not only for performance reasons, but because an underinflated tire has a smaller circumference and therefore rotates faster than a properly inflated tire. That will make the WSS send an incorrect signal to the Controller.

ABS CONTROL MODULE

Note: An ABS Control Module (EBCM) is not serviceable and must be replaced if defective. Some service procedures can also involve the Powertrain Control Module (PCM), especially with Traction Control or Stability Control.

Service Precautions Regarding the EBCM:

- When Testing for Open or Short Circuits, never Ground or apply Voltage to any circuit unless instructed to do so by the service information.
- Never pierce connectors or wires; doing so breaks the seal which can result in a poor connection.
- Never apply or cut off Power to a Control Module while the Ignition is in the ON position.
- Interchanging EBCMs from one vehicle to another may change the braking distance and make the vehicle unsafe. This applies even if the parts are physically the same and have the same Primary Part numbers. ABS Controllers are Programmed for a specific vehicle's Length, Weight, Tire Size, Engine, etc. Therefore it is crucial that a replacement part have the same Specific Part Number (or a Superseded Part Number) when performing a component swap.

Assembly (On Vehicle)



Accessing EBCM Memory:

- Antilock Systems with Self-Diagnostic Capabilities store trouble codes in their Memory.
- The EBCM cannot recognize all system problems and failures. If Diagnostic Trouble Codes do not lead to a final diagnosis, follow other procedures.
- The EBCM also cannot store a DTC if the Module is not receiving Battery Power.
- Note: When servicing some Antilock Systems, Diagnostic Trouble Codes must be erased from the EBCM memory after making repairs. On other systems, DTCs will erase automatically once the fault is repaired.

WARNING LAMPS AND BRAKE SYSTEM DIAGNOSIS

Many Antilock Systems use two Dashboard Indicator Lights: a Red one marked BRAKE to signal a problem in the Service Brake System and a second yellow one to indicate problems with the ABS. As part of the Diagnostic Procedure, perform a Warning Lamp Sequence Test while observing when the lamps light up (and go out) or count the blinks of the Warning Lamp. Vehicles equipped with Traction Control (TCS) will also likely have a separate light to indicate TCS Operation or Fault.

Brake Warning Lamp



ABS Brake Warning Lamp



SERVICING A BRAKE PEDAL TRAVEL SWITCH

A **Brake Pedal Switch** monitors the Brake Pedal Position and sends its information to the PCM & EBCM. If the Brake Pedal Switch is not adjusted properly, or is not electrically connected, the ABS system will not operate correctly.

REGENERATIVE BRAKING

Some Hybrid Vehicles use the Kinetic Energy of a vehicle in motion to generate electricity. During this 'Regeneration' process, when the vehicle is decelerating, the Electric Motor that is normally used to power the vehicle becomes an Electric Generator.

In operation, when a driver pushes the brake pedal, a signal is sent to the Onboard Computer(s). But, instead of applying the Hydraulic Brakes, the Electric Motor is used to slow the vehicle. The wheels of the vehicle drive the Electric Motors (now generators), which produces Electrical Current that is sent to the Hybrid Storage Battery, and kept for later use to power the vehicle.

In emergencies, or high-speed Stops, the vehicle's Hydraulic Brakes are used to slow the vehicle. The components of a Regenerative Braking System include the Onboard Computers (used to control the Hybrid and Brake Systems), the Hybrid Electrical Motor, the Hybrid Electrical Circuits, and the Hybrid Storage Battery.

