

Lesson 13

Objective: Explore perimeter as an attribute of plane figures and solve problems.

Suggested Lesson Structure

■ Fluency Practice	(16 minutes)
■ Application Problem	(8 minutes)
■ Concept Development	(26 minutes)
■ Student Debrief	(10 minutes)
Total Time	(60 minutes)

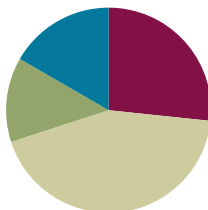

Fluency Practice (16 minutes)

- Multiply by 8 **3.OA.7** (8 minutes)
- Equivalent Counting with Units of 4 **3.OA.7** (4 minutes)
- Find the Perimeter **3.MD.8** (4 minutes)

Multiply by 8 (8 minutes)

Materials: (S) Multiply by 8 (1–5) Pattern Sheet

Note: This activity builds fluency with multiplication facts using units of 8. It works toward students knowing from memory all the products of two one-digit numbers. See Lesson 1 for the directions for administration of a Multiply-By Pattern Sheet.

T: (Write $5 \times 8 = \underline{\quad}$.) Let's skip-count up by eights to find the answer. (Raise a finger for each number to track the count. Record the skip-count answers on the board.)

S: 8, 16, 24, 32, 40.

T: (Circle 40, and write $5 \times 8 = 40$ above it. Write $3 \times 8 = \underline{\quad}$.) Let's skip-count up by eights again. (Track with fingers as students count.)

S: 8, 16, 24.

T: Let's see how we can skip-count down to find the answer, too. Start at 40 with 5 fingers, 1 for each eight. (Count down with fingers as students say the numbers.)

S: 40 (five fingers), 32 (4 fingers), 24 (3 fingers).

Repeat the process for 4×8 .

T: (Distribute the Multiply by 8 Pattern Sheet.) Let's practice multiplying by 8. Be sure to work left to right across the page.

Equivalent Counting with Units of 4 (4 minutes)

Note: This activity builds fluency with multiplication facts using units of 4.

- T: Count by fours to 40. (Write as students count.)
- S: 4, 8, 12, 16, 20, 24, 28, 32, 36, 40.
- T: (Write 1 four beneath the 4.) Count to 10 fours. (Write as students count.)

4	8	12	16	20	24	28	32	36	40
1 four	2 fours	3 fours	4 fours	5 fours	6 fours	7 fours	8 fours	9 fours	10 fours

- S: 1 four, 2 fours, 3 fours, 4 fours, 5 fours, 6 fours, 7 fours, 8 fours, 9 fours, 10 fours.
- T: Let’s count to 10 fours again. This time, stop when I raise my hand.
- S: 1 four, 2 fours, 3 fours.
- T: (Raise hand.) Say the multiplication sentence.
- S: $3 \times 4 = 12$.
- T: Continue.
- S: 4 fours, 5 fours.
- T: (Raise hand.) Say the multiplication sentence.
- S: $5 \times 4 = 20$.
- T: Continue the process up to 10 fours and down to 1 four.

Find the Perimeter (4 minutes)

Materials: (S) Personal white board

Note: This activity reviews Lesson 11.

- T: (Project 5 cm by 2 cm rectangle. Write $P = \underline{\hspace{1cm}} \text{ cm} + \underline{\hspace{1cm}} \text{ cm} + \underline{\hspace{1cm}} \text{ cm} + \underline{\hspace{1cm}} \text{ cm}$.) Copy the equation on your personal white board, and fill in the blanks.
- S: (Write $P = 5 \text{ cm} + 2 \text{ cm} + 5 \text{ cm} + 2 \text{ cm}$.)
- T: (Write $P = \underline{\hspace{1cm}} \text{ cm}$.) Solve your equation to find the perimeter.
- S: (Write $P = 14 \text{ cm}$.)

Continue the process with the other polygons.

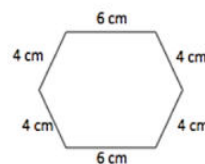
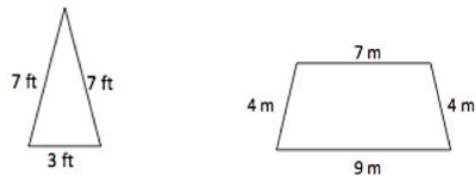
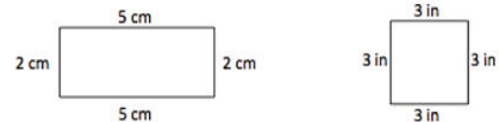

Application Problem (8 minutes)

Materials: (S) 3" × 5" index card, ruler

Use your index card to answer the questions.

- What is the perimeter of your index card in inches?
- Place the short end of your index card next to the short end of your partner's index card. Make a prediction: What do you think the perimeter is of the new shape you made?
- Find the perimeter of the new shape. Was your prediction right? Why or why not?

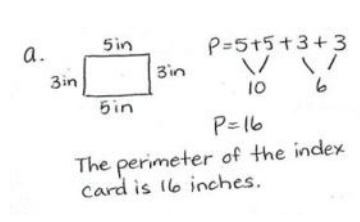
a.  $P = 5 + 5 + 3 + 3$
 $P = 16$
 The perimeter of the index card is 16 inches.

b. I think the perimeter of the new shape is double the perimeter of 1 index card.
 $P = 2 \times 16$
 $P = 16 + 16$
 $P = 32$

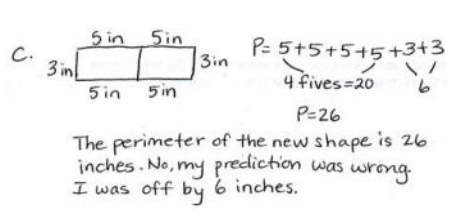
c.  $P = 5 + 5 + 5 + 5 + 3 + 3$
 $P = 26$
 The perimeter of the new shape is 26 inches. No, my prediction was wrong. I was off by 6 inches.

Note: This problem reviews Lesson 11's concept of measuring side lengths to calculate perimeter. Discuss the predictions that students made in part (b), and clear up any misconceptions about the perimeter of the new shape being double the perimeter of one index card.

Concept Development (26 minutes)

Materials: (S) Personal white board

Part 1: Calculate perimeter with given side lengths.

T: (Project the shape to the right.) How can you use the information in this picture to find the perimeter of the shape? Talk to a partner.

S: I can just add the side lengths! → Side lengths are given, so I can add them to find the perimeter.

T: Write and solve an equation that shows the perimeter as the sum of the given side lengths.

S: (Write $3 \text{ in} + 3 \text{ in} + 4 \text{ in} + 4 \text{ in} + 2 \text{ in} = 16 \text{ inches}$.)

T: Talk to a partner. What strategy did you use to solve?

S: I added the fours to get 8. $8 + 2 = 10$. Then, I added 2 threes to 10 to get 16. → I doubled 3 to get 6 and then added a 4 to make 10. Then, I added 4 plus 2 plus 10 to get 16. → I added 3 plus 4 to get 7. Then, I doubled 7 to get 14 and added 2 to 14 to get 16. → I did 4 times 4 by just using the two to change the threes to fours.

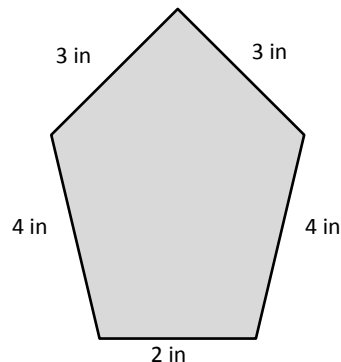

Repeat the process with the following possible suggestions.

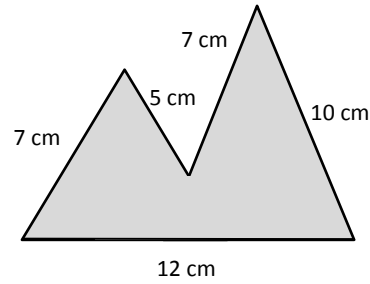
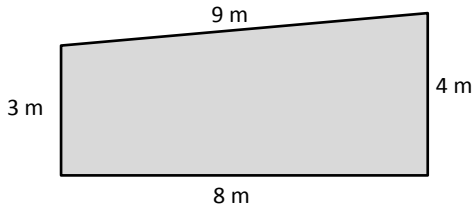

Part 2: Practice calculating the perimeter of various shapes with given side lengths.

Materials: (T) Timer (S) Quiz-Quiz-Trade cards (Template) (pictured to the right), personal white board

Students play Quiz-Quiz-Trade, applying what they learned in Part 1 to calculate the perimeters of various shapes using either mental math or their personal white boards.

Directions for Quiz-Quiz-Trade:

1. Each person gets 1 Quiz-Quiz-Trade card.
2. Calculate the perimeter of the shape on the card.
3. Quiz-Quiz: Ask a partner to calculate the perimeter of the shape on your card while you calculate the perimeter of the shape on your partner’s card. Try again if your answers for the same shape differ.
4. Trade: When both partners agree on the perimeters, trade cards, and repeat Step 3 with a new partner.

Prepare students by doing the following:

- Review strategies students can use to graciously verify the correctness of a calculation.
- Increase accountability and pace by setting a minimum number of trades to be made within a given time.
- Add a competitive element by giving students a point each time they correctly compute a perimeter.

Quiz-Quiz-Trade Cards Template

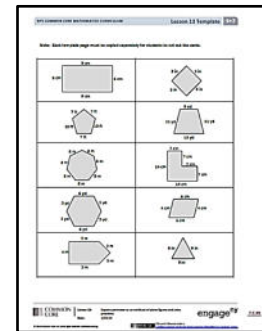
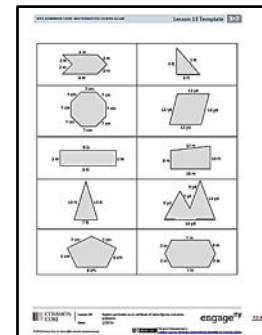

NOTES ON MULTIPLE MEANS OF ENGAGEMENT:

Consider adjusting the numbers to better suit students working below grade level in order for them to experience success. It may, however, be more effective to limit the number of cards students below grade level play, so they may develop speed through repetition.

Problem Set (10 minutes)

Students should do their personal best to complete the Problem Set within the allotted 10 minutes. For some classes, it may be appropriate to modify the assignment by specifying which problems they work on first. Some problems do not specify a method for solving. Students should solve these problems using the RDW approach used for Application Problems.

Student Debrief (10 minutes)

Lesson Objective: Explore perimeter as an attribute of plane figures and solve problems.

The Student Debrief is intended to invite reflection and active processing of the total lesson experience. Invite students to review their solutions for the Problem Set. They should check work by comparing answers with a partner before going over answers as a class. Look for misconceptions or misunderstandings that can be addressed in the Debrief. Guide students in a conversation to debrief the Problem Set and process the lesson.

Any combination of the questions below may be used to lead the discussion.

- Tell a partner the names of the shapes in Problem 1. Be as specific as possible. What information helped you name each shape?
- What multiplication sentence can you use to find the perimeter of the shape in Problem 1(b)? (This anticipates the work done in Lesson 15 of finding the perimeter of a regular polygon given one side length.)
- Can you think of the perimeter in Problem 2 as 4 tens plus 2 sixes? Why or why not?
- Compare the strategy you used to find the perimeter in Problem 3(a) to a partner's. How are your strategies similar? How are they different?
- Share your answer to Problem 3(b) with a partner.

NYS COMMON CORE MATHEMATICS CURRICULUM Lesson 13 Problem Set 3•7

Name Gina Date _____

1. Find the perimeter of the following shapes.

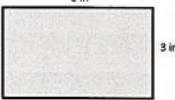
a.  $P = 3 \text{ in} + 8 \text{ in} + 3 \text{ in} + 8 \text{ in} = 22 \text{ in}$

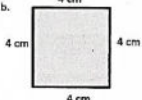
b.  $P = 4 \text{ cm} + 4 \text{ cm} + 4 \text{ cm} + 4 \text{ cm} = 16 \text{ cm}$

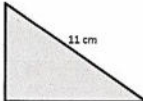
c.  $P = 11 \text{ cm} + 9 \text{ cm} + 6 \text{ cm} = 26 \text{ cm}$

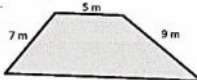
d.  $P = 15 \text{ m} + 5 \text{ m} + 9 \text{ m} + 9 \text{ m} = 36 \text{ m}$

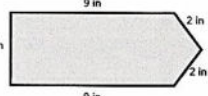
e.  $P = 9 \text{ in} + 9 \text{ in} + 2 \text{ in} + 2 \text{ in} + 3 \text{ in} = 25 \text{ in}$

COMMON CORE Lesson 13: Explore perimeter as an attribute of plane figures and solve problems. Date: 11/09/13 engage^{ny} 7.C.7

NYS COMMON CORE MATHEMATICS CURRICULUM Lesson 13 Problem Set 3•7

2. Alan's rectangular swimming pool is 10 meters long and 16 meters wide. What is the perimeter?

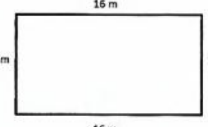
 $P = 16 \text{ m} + 16 \text{ m} + 10 \text{ m} + 10 \text{ m} = 32 \text{ m} + 20 \text{ m} = 52 \text{ m}$
The perimeter of the pool is 52 m.

3. Lila measures each side of the shape below.

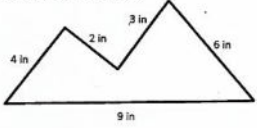

a. What is the perimeter of the shape?
 $P = 4 \text{ in} + 6 \text{ in} + 2 \text{ in} + 3 \text{ in} + 9 \text{ in} = 10 \text{ in} + 5 \text{ in} + 9 \text{ in} = 15 \text{ in} + 9 \text{ in} = 24 \text{ in}$
The perimeter of the shape is 24 inches.

b. Lila says the shape is a pentagon. Is she correct? Explain why or why not.
Yes, Lila is correct. The shape is a pentagon because it has 5 sides.

COMMON CORE Lesson 13: Explore perimeter as an attribute of plane figures and solve problems. Date: 11/09/13 engage^{ny} 7.C.8

Exit Ticket (3 minutes)

After the Student Debrief, instruct students to complete the Exit Ticket. A review of their work will help with assessing students' understanding of the concepts that were presented in today's lesson and planning more effectively for future lessons. The questions may be read aloud to the students.

Multiply.

$8 \times 1 = \underline{\quad\quad}$ $8 \times 2 = \underline{\quad\quad}$ $8 \times 3 = \underline{\quad\quad}$ $8 \times 4 = \underline{\quad\quad}$

$8 \times 5 = \underline{\quad\quad}$ $8 \times 1 = \underline{\quad\quad}$ $8 \times 2 = \underline{\quad\quad}$ $8 \times 1 = \underline{\quad\quad}$

$8 \times 3 = \underline{\quad\quad}$ $8 \times 1 = \underline{\quad\quad}$ $8 \times 4 = \underline{\quad\quad}$ $8 \times 1 = \underline{\quad\quad}$

$8 \times 5 = \underline{\quad\quad}$ $8 \times 1 = \underline{\quad\quad}$ $8 \times 2 = \underline{\quad\quad}$ $8 \times 3 = \underline{\quad\quad}$

$8 \times 2 = \underline{\quad\quad}$ $8 \times 4 = \underline{\quad\quad}$ $8 \times 2 = \underline{\quad\quad}$ $8 \times 5 = \underline{\quad\quad}$

$8 \times 2 = \underline{\quad\quad}$ $8 \times 1 = \underline{\quad\quad}$ $8 \times 2 = \underline{\quad\quad}$ $8 \times 3 = \underline{\quad\quad}$

$8 \times 1 = \underline{\quad\quad}$ $8 \times 3 = \underline{\quad\quad}$ $8 \times 2 = \underline{\quad\quad}$ $8 \times 3 = \underline{\quad\quad}$

$8 \times 4 = \underline{\quad\quad}$ $8 \times 3 = \underline{\quad\quad}$ $8 \times 5 = \underline{\quad\quad}$ $8 \times 3 = \underline{\quad\quad}$

$8 \times 4 = \underline{\quad\quad}$ $8 \times 1 = \underline{\quad\quad}$ $8 \times 4 = \underline{\quad\quad}$ $8 \times 2 = \underline{\quad\quad}$

$8 \times 4 = \underline{\quad\quad}$ $8 \times 3 = \underline{\quad\quad}$ $8 \times 4 = \underline{\quad\quad}$ $8 \times 5 = \underline{\quad\quad}$

$8 \times 4 = \underline{\quad\quad}$ $8 \times 5 = \underline{\quad\quad}$ $8 \times 1 = \underline{\quad\quad}$ $8 \times 5 = \underline{\quad\quad}$

$8 \times 2 = \underline{\quad\quad}$ $8 \times 5 = \underline{\quad\quad}$ $8 \times 3 = \underline{\quad\quad}$ $8 \times 5 = \underline{\quad\quad}$

$8 \times 4 = \underline{\quad\quad}$ $8 \times 2 = \underline{\quad\quad}$ $8 \times 4 = \underline{\quad\quad}$ $8 \times 3 = \underline{\quad\quad}$

$8 \times 5 = \underline{\quad\quad}$ $8 \times 3 = \underline{\quad\quad}$ $8 \times 2 = \underline{\quad\quad}$ $8 \times 4 = \underline{\quad\quad}$

$8 \times 3 = \underline{\quad\quad}$ $8 \times 5 = \underline{\quad\quad}$ $8 \times 2 = \underline{\quad\quad}$ $8 \times 4 = \underline{\quad\quad}$

multiply by 8 (1–5)

Name _____

Date _____

1. Find the perimeter of the following shapes.

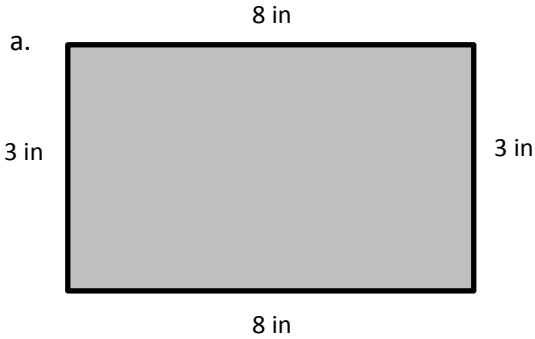

$$P = 3 \text{ in} + 8 \text{ in} + 3 \text{ in} + 8 \text{ in}$$

$$= \underline{\hspace{2cm}} \text{ in}$$

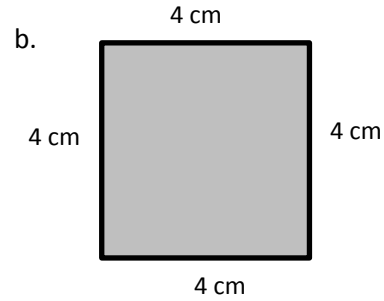

$$P = \underline{\hspace{1cm}} \text{ cm} + \underline{\hspace{1cm}} \text{ cm} + \underline{\hspace{1cm}} \text{ cm} + \underline{\hspace{1cm}} \text{ cm}$$

$$= \underline{\hspace{2cm}} \text{ cm}$$

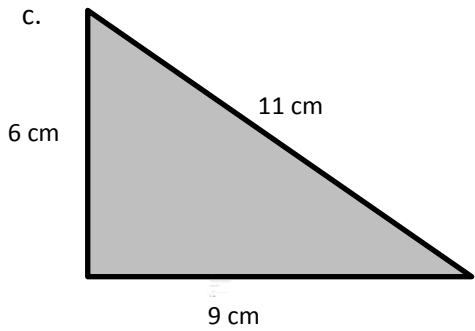

$$P = \underline{\hspace{1cm}} \text{ cm} + \underline{\hspace{1cm}} \text{ cm} + \underline{\hspace{1cm}} \text{ cm}$$

$$= \underline{\hspace{2cm}} \text{ cm}$$

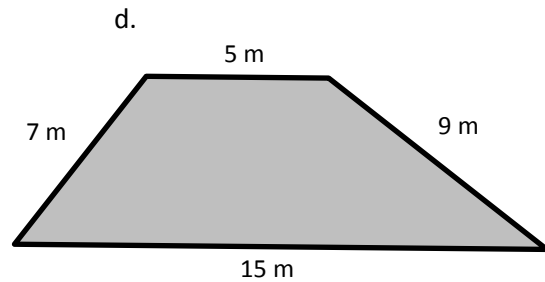

$$P = \underline{\hspace{1cm}} \text{ m} + \underline{\hspace{1cm}} \text{ m} + \underline{\hspace{1cm}} \text{ m} + \underline{\hspace{1cm}} \text{ m}$$

$$= \underline{\hspace{2cm}} \text{ m}$$

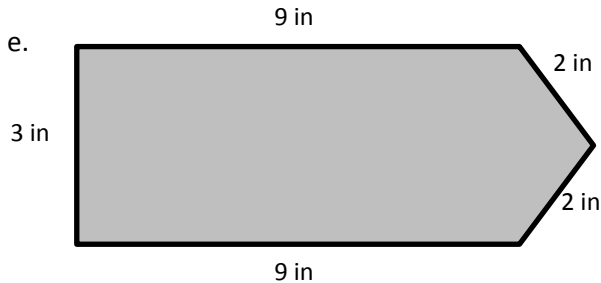

$$P = \underline{\hspace{1cm}} \text{ in} + \underline{\hspace{1cm}} \text{ in} + \underline{\hspace{1cm}} \text{ in} + \underline{\hspace{1cm}} \text{ in} + \underline{\hspace{1cm}} \text{ in}$$

$$= \underline{\hspace{2cm}} \text{ in}$$

2. Alan's rectangular swimming pool is 10 meters long and 16 meters wide. What is the perimeter?

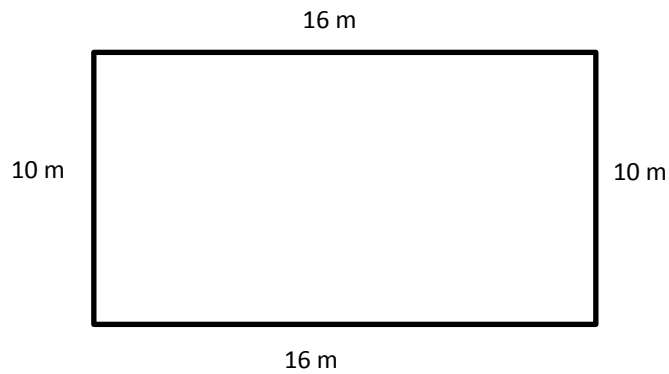

3. Lila measures each side of the shape below.

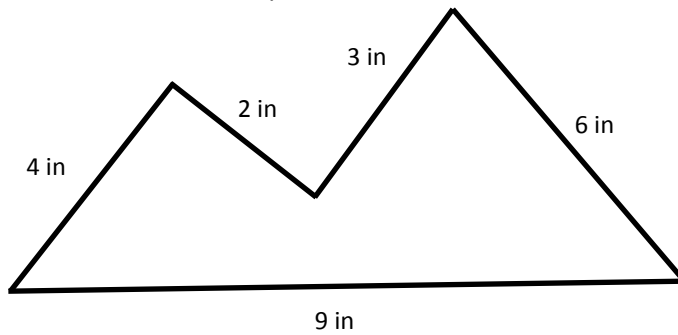

- a. What is the perimeter of the shape?
- b. Lila says the shape is a pentagon. Is she correct? Explain why or why not.

Name _____

Date _____

Which shape below has the greater perimeter? Explain your answer.

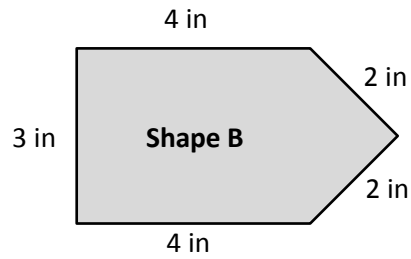
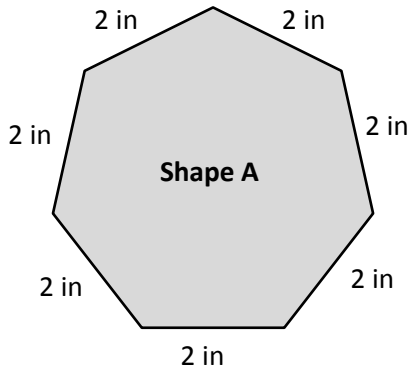

Name _____

Date _____

1. Find the perimeters of the shapes below. Include the units in your equations. Match the letter inside each shape to its perimeter to solve the riddle. The first one has been done for you.

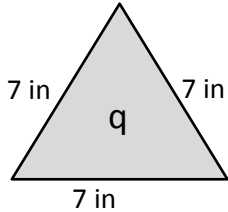

$$P = 7 \text{ in} + 7 \text{ in} + 7 \text{ in}$$

$$P = 21 \text{ in}$$

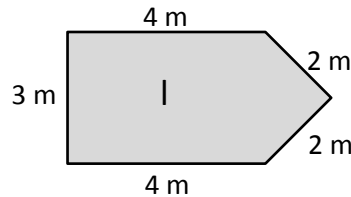
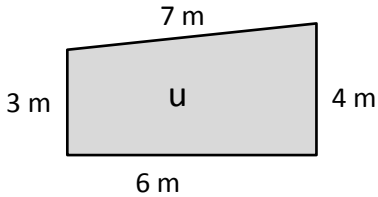
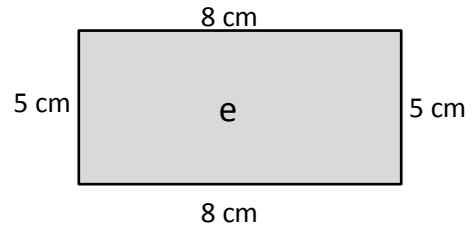
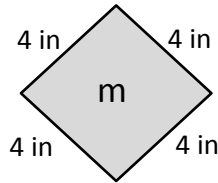
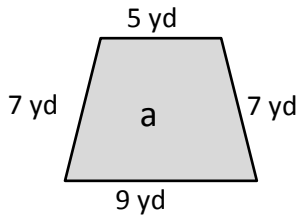
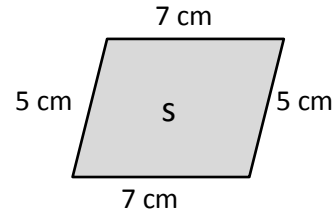
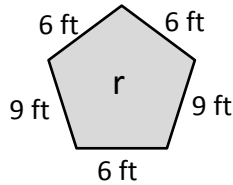

What kind of meals do math teachers eat?

_____ !
 24 21 20 28 36 26 16 26 28 15 24



2. Alicia’s rectangular garden is 33 feet long and 47 feet wide. What is the perimeter of Alicia’s garden?

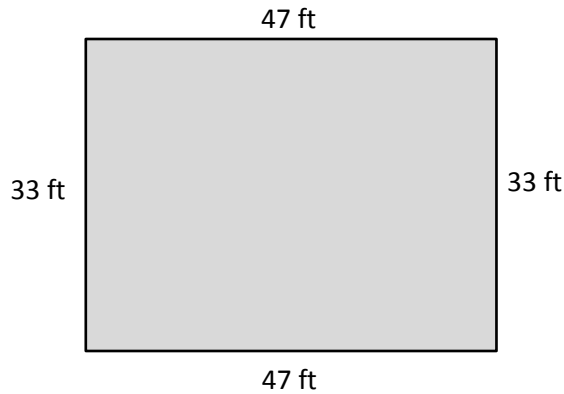

3. Jaques measured the side lengths of the shape below.

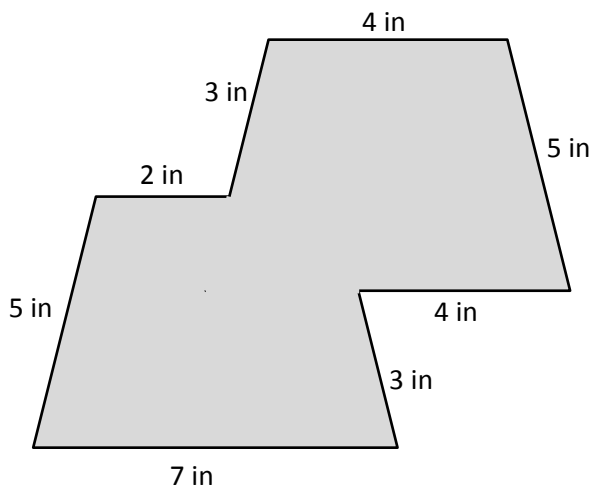

- a. Find the perimeter of Jaques’s shape.
- b. Jaques says his shape is an octagon. Is he right? Why or why not?

Note: Each Template page must be copied separately for students to cut out the cards.

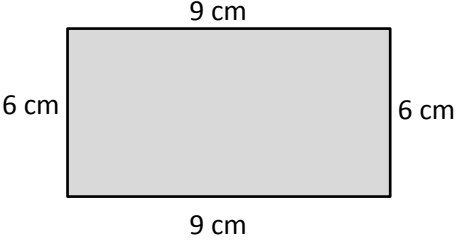
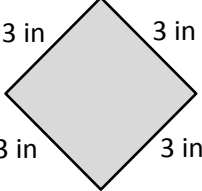
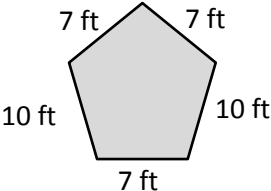
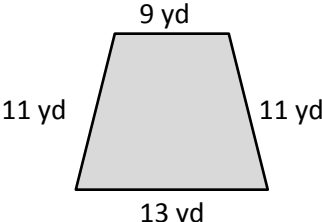
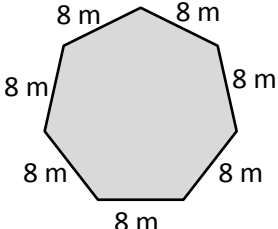
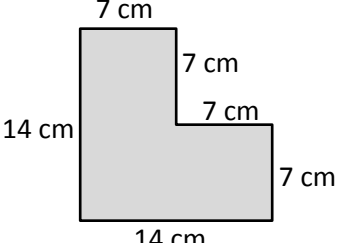
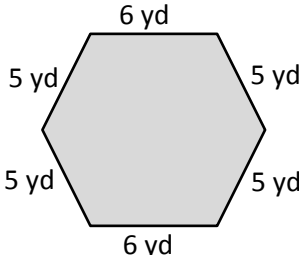
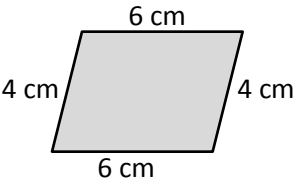
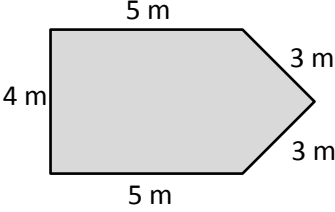
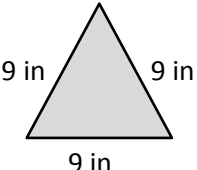
 <p>A rectangle with a top side of 9 cm, a bottom side of 9 cm, a left side of 6 cm, and a right side of 6 cm.</p>	 <p>A square rotated 45 degrees with all four sides labeled 3 in.</p>
 <p>A regular pentagon with all five sides labeled 7 ft.</p>	 <p>A trapezoid with a top base of 9 yd, a bottom base of 13 yd, and two slanted sides of 11 yd.</p>
 <p>A regular heptagon with all seven sides labeled 8 m.</p>	 <p>An L-shaped polygon with a left vertical side of 14 cm, a top horizontal side of 7 cm, a right vertical side of 7 cm, a bottom horizontal side of 14 cm, and an inner vertical side of 7 cm.</p>
 <p>A regular hexagon with all six sides labeled 5 yd.</p>	 <p>A parallelogram with top and bottom sides of 6 cm, and slanted sides of 4 cm.</p>
 <p>An irregular pentagon with a top horizontal side of 5 m, a left vertical side of 4 m, a bottom horizontal side of 5 m, and two slanted sides on the right of 3 m each.</p>	 <p>An equilateral triangle with all three sides labeled 9 in.</p>

quiz-quiz-trade cards

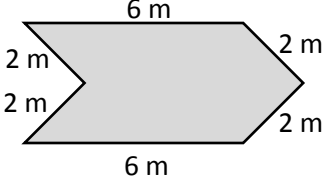
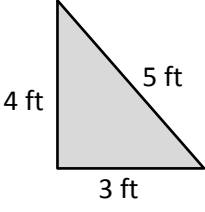
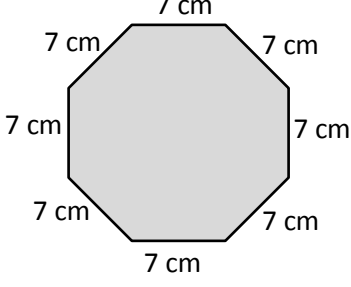
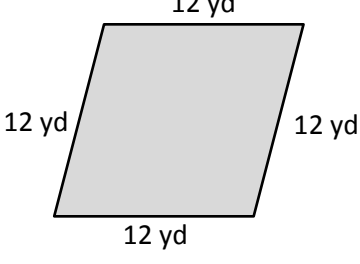
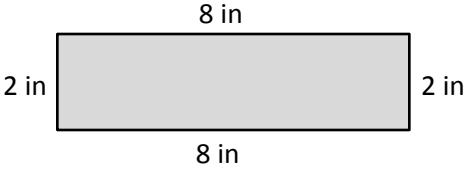
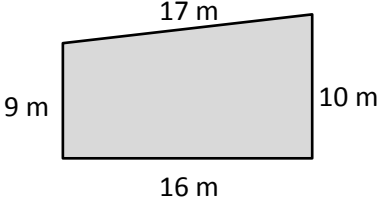
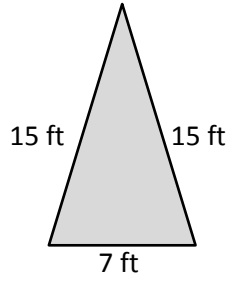
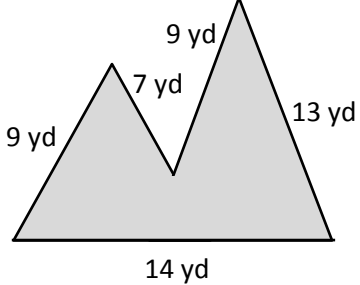
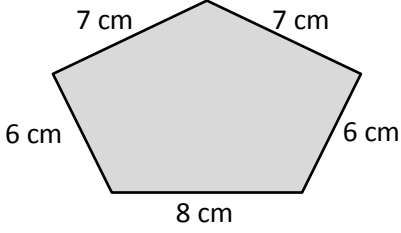
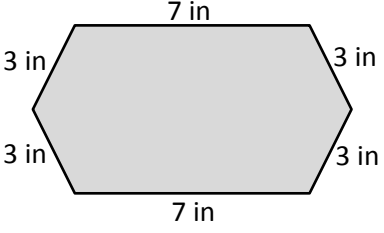
quiz-quiz-trade cards