

Lesson 14

Objective: Find areas by decomposing into rectangles or completing composite figures to form rectangles.

Suggested Lesson Structure

■ Fluency Practice	(15 minutes)
■ Application Problem	(5 minutes)
■ Concept Development	(30 minutes)
■ Student Debrief	(10 minutes)
Total Time	(60 minutes)

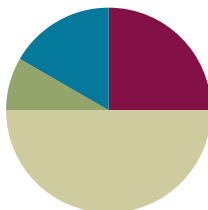

Fluency Practice (15 minutes)

- Group Counting **3.OA.1** (3 minutes)
- Multiply by 8 **3.OA.7** (7 minutes)
- Find the Area **3.MD.7** (5 minutes)

Group Counting (3 minutes)

Note: Group counting reviews interpreting multiplication as repeated addition.

Direct students to count forward and backward, occasionally changing the direction of the count.

- Fours to 40
- Sixes to 60
- Sevens to 70
- Nines to 90

Multiply by 8 (7 minutes)

Materials: (S) Multiply by 8 (6–10) Pattern Sheet

Note: This activity builds fluency with multiplication facts using units of 8. It works toward students knowing from memory all products of two one-digit numbers. See Lesson 2 for the directions for administration of a Multiply-By Pattern Sheet.

T: (Write $6 \times 8 = \underline{\quad}$.) Let's skip-count up by eights to solve. (Count with fingers to 6 as students count.)

S: 8, 16, 24, 32, 40, 48.

- T: Let's skip-count down to find the answer, too. Start at 80. (Count down with fingers as students count.)
- S: 80, 72, 64, 56, 48.
- T: Let's skip-count up again to find the answer, but this time, start at 40. (Count up with fingers as students count.)
- S: 40, 48.

Continue with the following possible sequence: 8×8 , 7×8 , and 9×8 .

- T: (Distribute Multiply by 8 (6–10) Pattern Sheet.) Let's practice multiplying by 8. Be sure to work left to right across the page.

Find the Area (5 minutes)

Materials: (S) Personal white board

Note: This fluency activity reviews the relationship between side lengths and area and supports the perception of the composite shapes by moving from part to whole using a grid.

- T: (Project the first figure on the right.) On your personal white board, write a number sentence to show the area of the shaded rectangle.
- S: (Write $5 \times 2 = 10$ or $2 \times 5 = 10$.)
- T: Write a number sentence to show the area of the unshaded rectangle.
- S: (Write $3 \times 2 = 6$ or $2 \times 3 = 6$.)
- T: (Write $__ \text{ sq units} + __ \text{ sq units} = __ \text{ sq units}$.) Using the areas of the shaded and unshaded rectangle, write an addition sentence to show the area of the entire figure.
- S: (Write $10 \text{ sq units} + 6 \text{ sq units} = 16 \text{ sq units}$ or $6 \text{ sq units} + 10 \text{ sq units} = 16 \text{ sq units}$.)

Continue with the other figures.

Figures for *Find the Area*

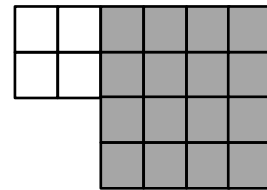
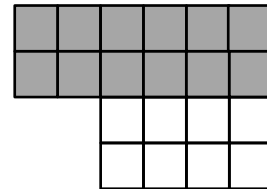
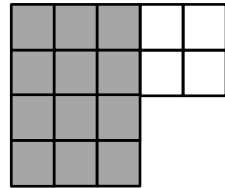
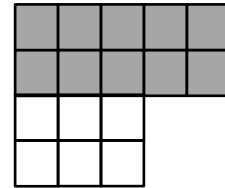

Application Problem (5 minutes)

- a. Break apart the shaded figure into 2 rectangles. Then, add to find the area of the shaded figure below.
- b. Subtract the area of the unshaded rectangle from the area of the large rectangle to check your answer in Part (a).

MP.7

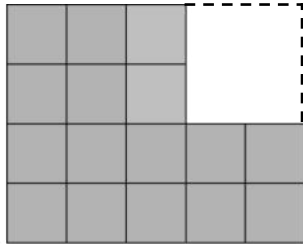

a. Area = 12 sq units + 4 sq units = 16 sq units

b. Area of large rectangle: 4 x 5 = 20
Area of shaded figure: 20 sq units - 4 sq units = 16 sq units

My answer for part (a) is correct because I got an area of 16 square units for both (a) and (b).

Note: This problem reviews the Lesson 13 concept of finding the area of composite shapes. Students may choose to break apart their rectangles in different ways for Part (a).

Concept Development (30 minutes)

Materials: (S) Personal white board, Problem Set

Problem 1: Choose an appropriate method for finding the area of a composite shape.

Distribute one Problem Set to each student. Project the shape on the right.

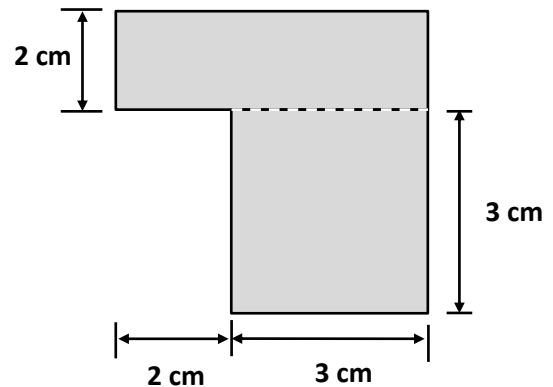

- T: What two strategies did we learn yesterday to find the area of a non-rectangular shape?
- S: We can break the shape apart into smaller rectangles, and then add the areas of the smaller rectangles together. → Or, we can find the area of the larger rectangle and subtract the area of the unknown part.
- T: Look at the figure in Problem 1(a).
- T: What is the unknown width?
- S: 5 centimeters! → 2 centimeters plus 3 centimeters is 5 centimeters.
- T: Label that on your figure. Then, write the equation used to find the area of each of the smaller rectangles.
- S: (Record on Problem Set.)



NOTES ON MULTIPLE MEANS OF ENGAGEMENT:

Students working below grade level may benefit from sentence frames to write equations to find the area in Problem 1. Provide the following written support, if necessary:

- ___ cm × ___ cm = ___ sq cm
- ___ cm × ___ cm = ___ sq cm
- ___ sq cm + ___ sq cm = ___ sq cm
- The area is ___ square centimeters.

- T: What is the area of the top rectangle?
 S: 10 square centimeters!
 T: What is the area of the bottom rectangle?
 S: 9 square centimeters!
 T: On your Problem Set, write the equation used to find the area of the whole figure. Be sure to answer in a complete sentence!
 T: What is the total area of the figure?
 S: 19 square centimeters!



**NOTES ON
 MULTIPLE MEANS
 OF ENGAGEMENT:**

Adjust the numbers in Problem 2 of the Concept Development to challenge students working above grade level. Or, offer an alternative challenge, such as scripting and recording the steps to find the area of a non-rectangular shape that they can refer to when needed.

Continue with Problem 1(b) from the Problem Set.

Problem 2: Solve a word problem involving the area of non-rectangular shapes.

Write or project the following problem: Fanny has a piece of fabric 8 feet long and 5 feet wide. She cuts out a rectangular piece that measures 3 feet by 2 feet. How many square feet of fabric does Fanny have left?

- T: Draw and label Fanny’s fabric.
 T: How big is the piece that Fanny cuts out?
 S: 3 ft by 2 ft.
 T: Work with your partner to draw the piece of fabric that Fanny cuts out. Label the measurements of the piece being cut out. (Note: The 3-ft by 2-ft piece can be taken out of any part of the original rectangle, including at an angle.)
 S: (Draw as shown to the right.)
 T: What’s the best way for us to find the area of the remaining fabric?
 S: Find the area of the original piece, then subtract the area of what was cut out.
 T: Write an equation to find the area of the original piece of fabric.
 S: (Write $8 \times 5 = 40$.)
 T: Beneath what you just wrote, write an equation to find the area of the piece of fabric Fanny cuts out.
 T: What is the area of the piece that is cut out?
 S: 6 square feet!
 T: What expression tells us the area of the remaining fabric?
 S: $40 - 6$.
 T: $40 - 6$ equals...?
 S: 34.
 T: How much fabric does Fanny have left?
 S: 34 square feet!

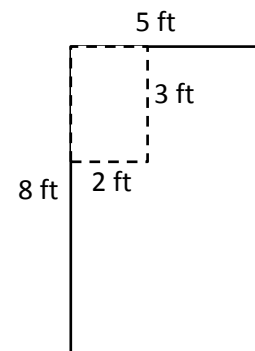
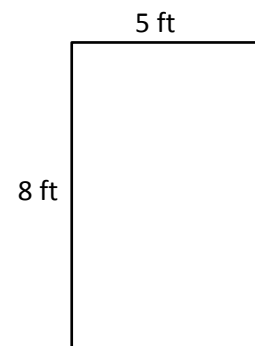

Problem Set (10 minutes)

Students should do their personal best to complete the Problem Set within the allotted 10 minutes. For some classes, it may be appropriate to modify the assignment by specifying which problems they work on first. Some problems do not specify a method for solving. Students should solve these problems using the RDW approach used for Application Problems.

Student Debrief (10 minutes)

Lesson Objective: Find areas by decomposing into rectangles or completing composite figures to form rectangles.

The Student Debrief is intended to invite reflection and active processing of the total lesson experience.

Invite students to review their solutions for the Problem Set. They should check work by comparing answers with a partner before going over answers as a class. Look for misconceptions or misunderstandings that can be addressed in the Debrief. Guide students in a conversation to debrief the Problem Set and process the lesson.

Any combination of the questions below may be used to lead the discussion.

- Lead a discussion about the strategy choice for Problems 1(a) and 1(b). Could the strategies have been reversed for these two problems?
- What steps did you need to follow to solve Problem 2? How were you able to find the area of the smaller rectangle?
- Invite students to share their drawings for Problem 3. In what ways are they similar? In what ways are they different?
- Why did Tila and Evan wind up with the same amount of paper in Problem 4? If they both cut their rectangles from the corners of their papers, would they both be able to cut out a 4-cm by 8-cm rectangle with their remaining paper? (Guide students to reason that, although they both have 42 sq cm left and the 4 × 8 rectangle only measures 32 sq cm, only Evan can cut out such a rectangle from his remaining paper.)

NYS COMMON CORE MATHEMATICS CURRICULUM Lesson 14 Problem Set 3•4

Name: Gina Date: _____

1. Find the area of each of the following figures. All figures are made up of rectangles.

a. $2\text{ cm} \times 5\text{ cm} = 10\text{ sq cm}$
 $3\text{ cm} \times 3\text{ cm} = 9\text{ sq cm}$
 $10\text{ sq cm} + 9\text{ sq cm} = 19\text{ sq cm}$
 The area is 19 sq cm.

b. $4\text{ m} \times 3\text{ m} = 12\text{ sq m}$
 $2\text{ m} \times 1\text{ m} = 2\text{ sq m}$
 $12\text{ sq m} - 2\text{ sq m} = 10\text{ sq m}$
 The area is 10 sq m.

2. The figure below shows a small rectangle in a big rectangle. Find the area of the shaded part of the figure.

$5\text{ m} \times 6\text{ m} = 30\text{ sq m}$
 $2\text{ m} \times 3\text{ m} = 6\text{ sq m}$
 $30\text{ sq m} - 6\text{ sq m} = 24\text{ sq m}$
 The area is 24 sq m.

EUREKA MATH Lesson 14: Find areas by decomposing into rectangles or completing composite figures to form rectangles. engage^{ny} 8

NYS COMMON CORE MATHEMATICS CURRICULUM Lesson 14 Problem Set 3•4

3. A paper rectangle has a length of 6 inches and a width of 8 inches. A square with a side length of 3 inches was cut out of it. What is the area of the remaining paper?

$6\text{ in} \times 8\text{ in} = 48\text{ sq in}$
 $3\text{ in} \times 3\text{ in} = 9\text{ sq in}$
 $48\text{ sq in} - 9\text{ sq in} = 39\text{ sq in}$
 The area of the remaining paper is 39 sq in.

4. Tila and Evan both have paper rectangles measuring 6 cm by 9 cm. Tila cuts a 3 cm by 4 cm rectangle out of hers, and Evan cuts a 2 cm by 6 cm rectangle out of his. Tila says she has more paper left over. Evan says they have the same amount. Who is correct? Show your work below.

Tila $6\text{ cm} \times 9\text{ cm} = 54\text{ sq cm}$
 $3\text{ cm} \times 4\text{ cm} = 12\text{ sq cm}$
 $54\text{ sq cm} - 12\text{ sq cm} = 42\text{ sq cm}$

Evan $6\text{ cm} \times 9\text{ cm} = 54\text{ sq cm}$
 $2\text{ cm} \times 6\text{ cm} = 12\text{ sq cm}$
 $54\text{ sq cm} - 12\text{ sq cm} = 42\text{ sq cm}$

Evan is correct, they both have 42 sq cm of paper left.

EUREKA MATH Lesson 14: Find areas by decomposing into rectangles or completing composite figures to form rectangles. engage^{ny} 9

Exit Ticket (3 minutes)

After the Student Debrief, instruct students to complete the Exit Ticket. A review of their work will help with assessing students' understanding of the concepts that were presented in today's lesson and planning more effectively for future lessons. The questions may be read aloud to the students.

Multiply.

$8 \times 1 = \underline{\quad}$ $8 \times 2 = \underline{\quad}$ $8 \times 3 = \underline{\quad}$ $8 \times 4 = \underline{\quad}$

$8 \times 5 = \underline{\quad}$ $8 \times 6 = \underline{\quad}$ $8 \times 7 = \underline{\quad}$ $8 \times 8 = \underline{\quad}$

$8 \times 9 = \underline{\quad}$ $8 \times 10 = \underline{\quad}$ $8 \times 5 = \underline{\quad}$ $8 \times 6 = \underline{\quad}$

$8 \times 5 = \underline{\quad}$ $8 \times 7 = \underline{\quad}$ $8 \times 5 = \underline{\quad}$ $8 \times 8 = \underline{\quad}$

$8 \times 5 = \underline{\quad}$ $8 \times 9 = \underline{\quad}$ $8 \times 5 = \underline{\quad}$ $8 \times 10 = \underline{\quad}$

$8 \times 6 = \underline{\quad}$ $8 \times 5 = \underline{\quad}$ $8 \times 6 = \underline{\quad}$ $8 \times 7 = \underline{\quad}$

$8 \times 6 = \underline{\quad}$ $8 \times 8 = \underline{\quad}$ $8 \times 6 = \underline{\quad}$ $8 \times 9 = \underline{\quad}$

$8 \times 6 = \underline{\quad}$ $8 \times 7 = \underline{\quad}$ $8 \times 6 = \underline{\quad}$ $8 \times 7 = \underline{\quad}$

$8 \times 8 = \underline{\quad}$ $8 \times 7 = \underline{\quad}$ $8 \times 9 = \underline{\quad}$ $8 \times 7 = \underline{\quad}$

$8 \times 8 = \underline{\quad}$ $8 \times 6 = \underline{\quad}$ $8 \times 8 = \underline{\quad}$ $8 \times 7 = \underline{\quad}$

$8 \times 8 = \underline{\quad}$ $8 \times 9 = \underline{\quad}$ $8 \times 9 = \underline{\quad}$ $8 \times 6 = \underline{\quad}$

$8 \times 9 = \underline{\quad}$ $8 \times 7 = \underline{\quad}$ $8 \times 9 = \underline{\quad}$ $8 \times 8 = \underline{\quad}$

$8 \times 9 = \underline{\quad}$ $8 \times 8 = \underline{\quad}$ $8 \times 6 = \underline{\quad}$ $8 \times 9 = \underline{\quad}$

$8 \times 7 = \underline{\quad}$ $8 \times 9 = \underline{\quad}$ $8 \times 6 = \underline{\quad}$ $8 \times 8 = \underline{\quad}$

$8 \times 9 = \underline{\quad}$ $8 \times 7 = \underline{\quad}$ $8 \times 6 = \underline{\quad}$ $8 \times 8 = \underline{\quad}$

multiply by 8 (6–10)

Name _____

Date _____

1. Find the area of each of the following figures. All figures are made up of rectangles.

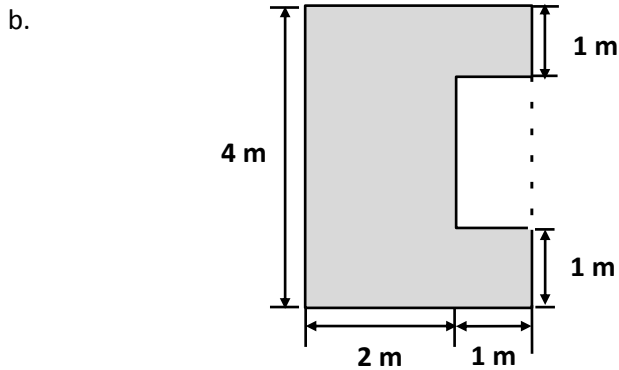
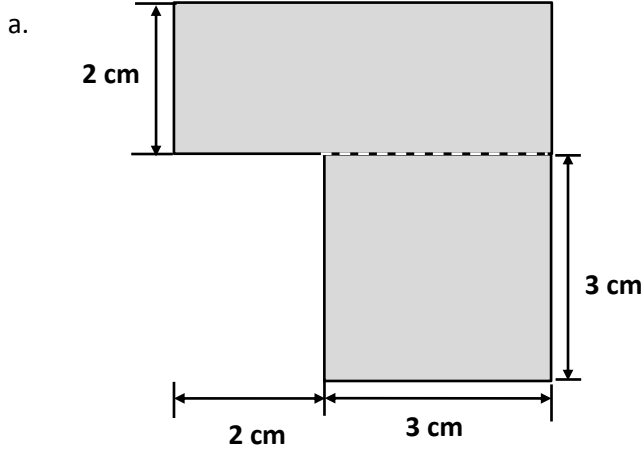

2. The figure below shows a small rectangle in a big rectangle. Find the area of the shaded part of the figure.

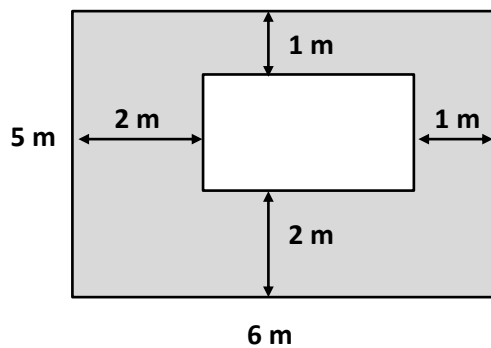

3. A paper rectangle has a length of 6 inches and a width of 8 inches. A square with a side length of 3 inches was cut out of it. What is the area of the remaining paper?
4. Tila and Evan both have paper rectangles measuring 6 cm by 9 cm. Tila cuts a 3 cm by 4 cm rectangle out of hers, and Evan cuts a 2 cm by 6 cm rectangle out of his. Tila says she has more paper left over. Evan says they have the same amount. Who is correct? Show your work below.

Name _____

Date _____

Mary draws an 8 cm by 6 cm rectangle on her grid paper. She shades a square with a side length of 4 cm inside her rectangle. What area of the rectangle is left unshaded?

Name _____

Date _____

1. Find the area of each of the following figures. All figures are made up of rectangles.

a.

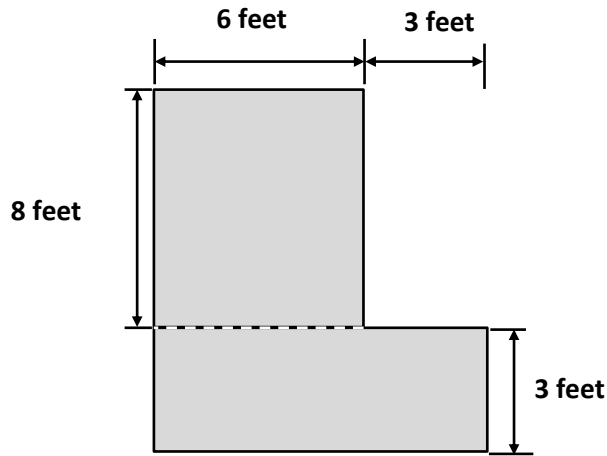

b.

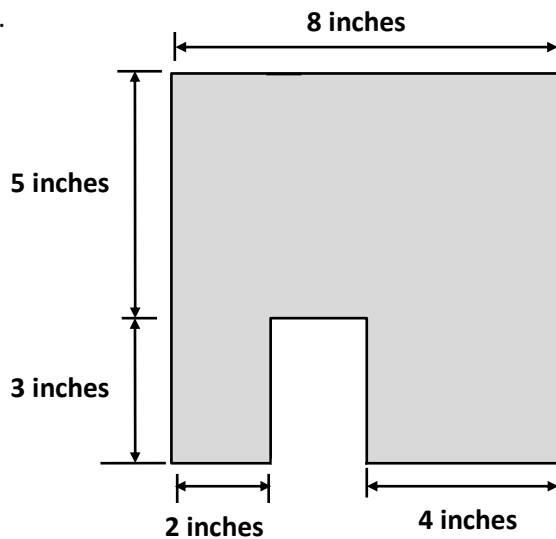

2. The figure below shows a small rectangle cut out of a big rectangle.

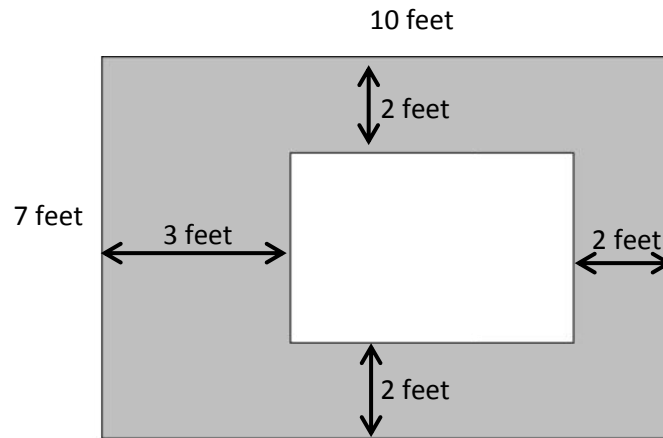

a. Label the side lengths of the unshaded region.

b. Find the area of the shaded region.