

Lesson 15

Objective: Relate arrays to tape diagrams to model the commutative property of multiplication.

Suggested Lesson Structure

■ Fluency Practice	(11 minutes)
■ Application Problem	(5 minutes)
■ Concept Development	(34 minutes)
■ Student Debrief	(10 minutes)
Total Time	(60 minutes)

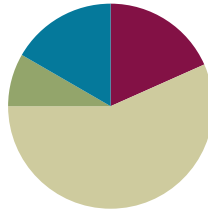

Fluency Practice (11 minutes)

- Multiply by 4 Pattern Sheet **3.OA.7** (8 minutes)
- Group Counting **3.OA.1** (3 minutes)

Multiply by 4 (8 minutes)

Materials: (S) Multiply by 4 (1–5) (Pattern Sheet)

Note: This activity builds fluency with multiplication facts using units of 4. It works toward the goal of students knowing from memory all products of two one-digit numbers. See Lesson 9 for the directions for administering a Multiply-By Pattern Sheet.

T: (Write $5 \times 4 = \underline{\quad}$.) Let's skip-count up by fours to find the answer. (Count with fingers to 5 as students count. Record the skip-count answers on the board.)

S: 4, 8, 12, 16, 20.

T: (Circle 20 and write $5 \times 4 = 20$ above it. Write $4 \times 4 = \underline{\quad}$.) Let's skip-count up by fours again. (Count with fingers to 4 as students count.)

S: 4, 8, 12, 16.

T: Let's see how we can skip-count down to find the answer to 4×4 . Start at 20. (Count down with fingers as students say numbers.)

S: 20, 16.

Repeat the process for 3×4 .

T: Let's practice multiplying by 4. Be sure to work left to right across the page. (Distribute Multiply by 4 Pattern Sheet.)

Group Counting (3 minutes)

Note: Group counting reviews interpreting multiplication as repeated addition. Counting by twos and threes in this activity reviews multiplication with units of 2 and 3 from Topics C and D.

- T: Let’s count by twos. (Direct students to count forward and backward to 20.)
- T: Let’s count by threes. (Direct students to count forward and backward to 30.)

Application Problem (5 minutes)

A cell phone is about 4 inches long. About how long are 9 cell phones laid end to end?

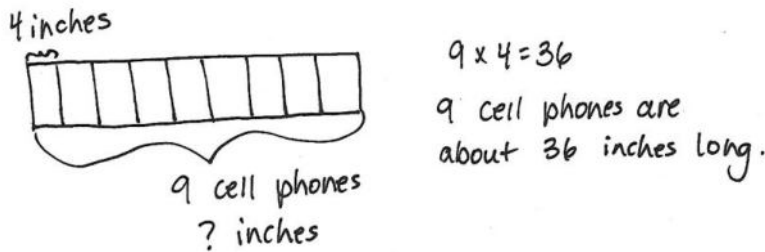

Note: This problem reviews multiplication using units of 4 from Lesson 14. It provides an opportunity to review using tape diagrams as tools for solving multiplication problems, which students further explore in today’s lesson.

Concept Development (34 minutes)

Materials: (S) Personal white board, blank paper with $\frac{1}{3}$ folded (shown to the right)

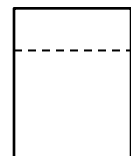

Pictorial: Relate arrays to tape diagrams.

Each student starts with one piece of blank, folded paper (shown to the right).

- T: Draw an array with 2 rows and 4 columns above the fold on your paper. Use the array to remind your partner about what the commutative property is. Turn your paper if you need to.
- S: (May rotate array 90 degrees.) The factors can switch places or trade meanings, but the total stays the same.
- T: Use the commutative property to write two multiplication equations for the array. Write them on the left side of the paper below the fold, one above the other.
- S: (Write $2 \times 4 = 8$ and $4 \times 2 = 8$.)
- T: Next to each equation, draw and label a tape diagram to match. Make sure the diagrams are the same size because they both represent the same total.

MP.7

- S: (Draw two diagrams, shown to the right.)
- T: Explain to a partner how your tape diagrams relate to the array.
- S: (Discuss.)
- T: The array shows commutativity, and so do the tape diagrams as we compare them. Why is that true?
- S: What the factors represent in the tape diagrams changes to number of units or size of units. It depends on what the factors represent in the equations or in the array. → The tape diagrams are just a different way to represent the multiplication.

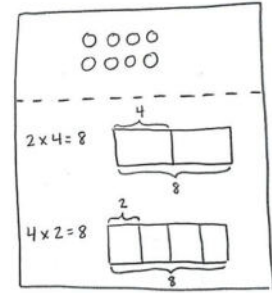

Repeat the process with 9×4 . To facilitate comparing tape diagrams, remind students to draw diagrams of the same size.

Pictorial–Abstract: Model commutativity using arrays and tape diagrams.

Provide students with two examples: 5×4 and 4×7 .

Make further practice less guided. Ask students to do the following:

- Draw arrays to match the expressions.
- Write two equations for each array.
- Draw and label tape diagrams to represent the commutativity for each set of facts.

After they have completed both examples, invite students to share and discuss their work.

- T: Why is it that an array can show two multiplication sentences, but a tape diagram can only show one multiplication sentence?
- S: Because if you turn the tape diagram, the number of units and their size doesn't change. They just look different. → That's why we need two tape diagrams to model the commutativity of one array.

Problem Set (10 minutes)

Students should do their personal best to complete the Problem Set within the allotted 10 minutes. For some classes, it may be appropriate to modify the assignment by specifying which problems they work on first. Some problems do not specify a method for solving. Students should solve these problems using the RDW approach used for Application Problems.



NOTES ON MULTIPLE MEANS OF ENGAGEMENT:

Place students in groups or partners according to ability, or allow students to work on their own. Consider giving them the option of self-selecting their levels of independence.

NYS COMMON CORE MATHEMATICS CURRICULUM Lesson 15 Problem Set 3•1

Name: Gina Date: _____

1. Label the tape diagrams and complete the equations. Then draw an array to represent the problems.

a. $2 \times 4 = 8$
 $4 \times 2 = 8$

b. $3 \times 4 = 12$
 $4 \times 3 = 12$

c. $7 \times 4 = 28$
 $4 \times 7 = 28$

COMMON CORE Lesson 15: Relate arrays to tape diagrams to model the commutative property of multiplication. Date: 5/2/14 engage^{ny} 1.E.20

Student Debrief (10 minutes)

Lesson Objective: Relate arrays to tape diagrams to model the commutative property of multiplication.

The Student Debrief is intended to invite reflection and active processing of the total lesson experience.

Invite students to review their solutions for the Problem Set. They should check work by comparing answers with a partner before going over answers as a class. Look for misconceptions or misunderstandings that can be addressed in the Debrief. Guide students in a conversation to debrief the Problem Set and process the lesson.

Any combination of the questions below may be used to lead the discussion.

- Students may have drawn different arrays for Problems 1(a), 1(b), and 1(c). Compare differences and discuss why both arrays reflect both diagrams.
- Compare Problems 3 and 4. Notice the model of commutativity even with different contexts.
- How do the array and the two tape diagrams show commutativity?
- How does the commutative property help us learn new multiplication facts?

Exit Ticket (3 minutes)

After the Student Debrief, instruct students to complete the Exit Ticket. A review of their work will help with assessing students' understanding of the concepts that were presented in today's lesson and planning more effectively for future lessons. The questions may be read aloud to the students.

2. Draw and label 2 tape diagrams to model why the statement in the box is true. $4 \times 6 = 6 \times 4$

3. Grace picks 4 flowers from her garden. Each flower has 8 petals. Draw and label a tape diagram to show how many petals there are in total.

4. Michael counts 8 chairs in his dining room. Each chair has 4 legs. How many chair legs are there all together?

NOTES ON MULTIPLE MEANS OF ENGAGEMENT:

The last bullet anticipates **3.OA.9**, not formally taught until Module 3. Students who need a challenge may use the commutative property to write known facts using units of 2, 3, 4, 5, and 10. They will realize they already know more than half of their facts!

Multiply.

$4 \times 1 = \underline{\quad\quad\quad}$ $4 \times 2 = \underline{\quad\quad\quad}$ $4 \times 3 = \underline{\quad\quad\quad}$ $4 \times 4 = \underline{\quad\quad\quad}$

$4 \times 5 = \underline{\quad\quad\quad}$ $4 \times 1 = \underline{\quad\quad\quad}$ $4 \times 2 = \underline{\quad\quad\quad}$ $4 \times 1 = \underline{\quad\quad\quad}$

$4 \times 3 = \underline{\quad\quad\quad}$ $4 \times 1 = \underline{\quad\quad\quad}$ $4 \times 4 = \underline{\quad\quad\quad}$ $4 \times 1 = \underline{\quad\quad\quad}$

$4 \times 5 = \underline{\quad\quad\quad}$ $4 \times 1 = \underline{\quad\quad\quad}$ $4 \times 2 = \underline{\quad\quad\quad}$ $4 \times 3 = \underline{\quad\quad\quad}$

$4 \times 2 = \underline{\quad\quad\quad}$ $4 \times 4 = \underline{\quad\quad\quad}$ $4 \times 2 = \underline{\quad\quad\quad}$ $4 \times 5 = \underline{\quad\quad\quad}$

$4 \times 2 = \underline{\quad\quad\quad}$ $4 \times 1 = \underline{\quad\quad\quad}$ $4 \times 2 = \underline{\quad\quad\quad}$ $4 \times 3 = \underline{\quad\quad\quad}$

$4 \times 1 = \underline{\quad\quad\quad}$ $4 \times 3 = \underline{\quad\quad\quad}$ $4 \times 2 = \underline{\quad\quad\quad}$ $4 \times 3 = \underline{\quad\quad\quad}$

$4 \times 4 = \underline{\quad\quad\quad}$ $4 \times 3 = \underline{\quad\quad\quad}$ $4 \times 5 = \underline{\quad\quad\quad}$ $4 \times 3 = \underline{\quad\quad\quad}$

$4 \times 4 = \underline{\quad\quad\quad}$ $4 \times 1 = \underline{\quad\quad\quad}$ $4 \times 4 = \underline{\quad\quad\quad}$ $4 \times 2 = \underline{\quad\quad\quad}$

$4 \times 4 = \underline{\quad\quad\quad}$ $4 \times 3 = \underline{\quad\quad\quad}$ $4 \times 4 = \underline{\quad\quad\quad}$ $4 \times 5 = \underline{\quad\quad\quad}$

$4 \times 4 = \underline{\quad\quad\quad}$ $4 \times 5 = \underline{\quad\quad\quad}$ $4 \times 1 = \underline{\quad\quad\quad}$ $4 \times 5 = \underline{\quad\quad\quad}$

$4 \times 2 = \underline{\quad\quad\quad}$ $4 \times 5 = \underline{\quad\quad\quad}$ $4 \times 3 = \underline{\quad\quad\quad}$ $4 \times 5 = \underline{\quad\quad\quad}$

$4 \times 4 = \underline{\quad\quad\quad}$ $4 \times 2 = \underline{\quad\quad\quad}$ $4 \times 4 = \underline{\quad\quad\quad}$ $4 \times 3 = \underline{\quad\quad\quad}$

$4 \times 5 = \underline{\quad\quad\quad}$ $4 \times 3 = \underline{\quad\quad\quad}$ $4 \times 2 = \underline{\quad\quad\quad}$ $4 \times 4 = \underline{\quad\quad\quad}$

$4 \times 3 = \underline{\quad\quad\quad}$ $4 \times 5 = \underline{\quad\quad\quad}$ $4 \times 2 = \underline{\quad\quad\quad}$ $4 \times 4 = \underline{\quad\quad\quad}$

multiply by 4 (1–5)

Name _____

Date _____

1. Label the tape diagrams and complete the equations. Then, draw an array to represent the problems.

a.

$2 \times 4 = \underline{\hspace{2cm}}$

$4 \times 2 = \underline{\hspace{2cm}}$

b.

$\underline{\hspace{2cm}} \times 4 = \underline{\hspace{2cm}}$

$4 \times \underline{\hspace{2cm}} = \underline{\hspace{2cm}}$

c.

$\underline{\hspace{2cm}} \times \underline{\hspace{2cm}} = 28$

$\underline{\hspace{2cm}} \times \underline{\hspace{2cm}} = 28$

2. Draw and label 2 tape diagrams to model why the statement in the box is true.

$$4 \times 6 = 6 \times 4$$

3. Grace picks 4 flowers from her garden. Each flower has 8 petals. Draw and label a tape diagram to show how many petals there are in total.

4. Michael counts 8 chairs in his dining room. Each chair has 4 legs. How many chair legs are there altogether?

Name _____

Date _____

Draw and label 2 tape diagrams to show that $4 \times 3 = 3 \times 4$. Use your diagrams to explain how you know the statement is true.

Name _____

Date _____

1. Label the tape diagrams and complete the equations. Then, draw an array to represent the problems.

a.

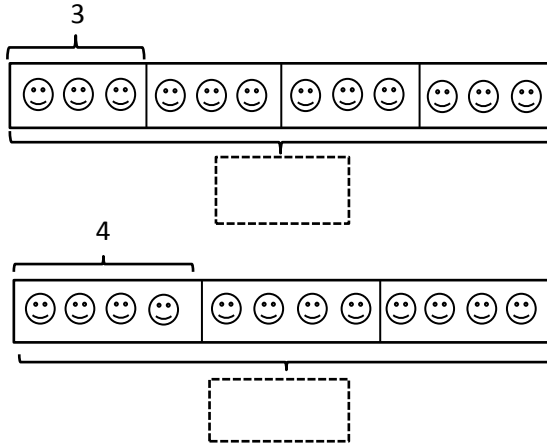

$4 \times 3 = \underline{\quad}$

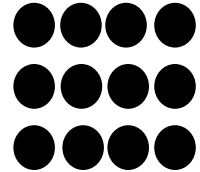

$3 \times 4 = \underline{\quad}$

b.

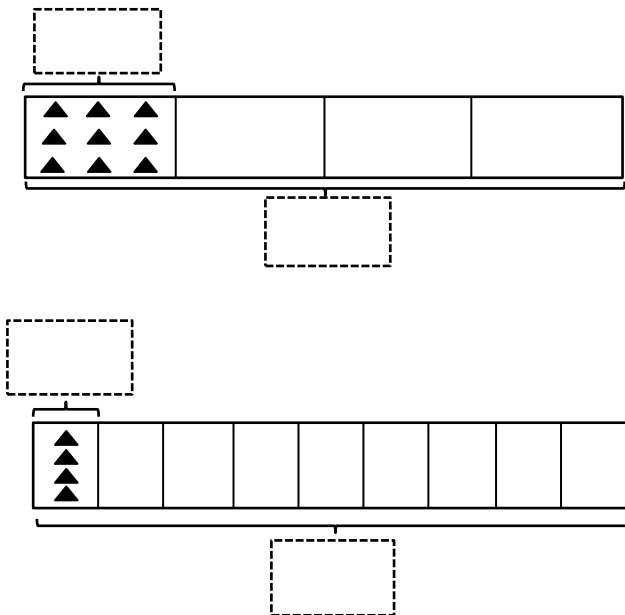

$4 \times \underline{\quad} = \underline{\quad}$

$\underline{\quad} \times 4 = \underline{\quad}$

C.

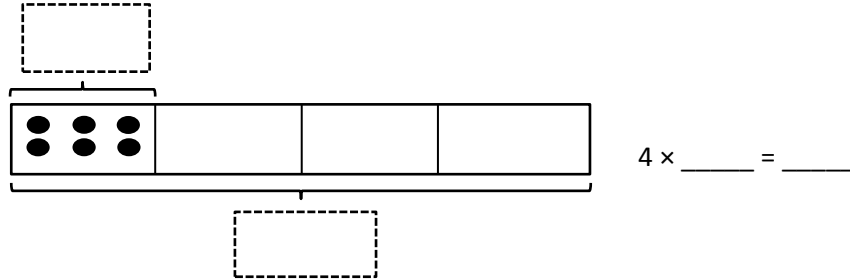
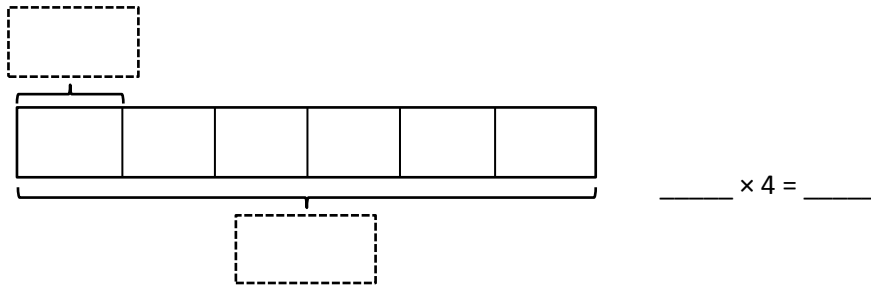

2. Seven clowns hold 4 balloons each at the fair. Draw and label a tape diagram to show the total number of balloons the clowns hold.

3. George swims 7 laps in the pool each day. How many laps does George swim after 4 days?