

Linear Modeling/Regression

FUNCTION NOTATION

Given the function notation of a coordinate:

a) Rewrite the coordinate as (x, y) b) Plot the point on the graph and give the quadrant it lies in

- 1) $f(3) = 4$ 2) $f(-2) = 3$ 3) $f(-4) = -2$ 4) $f(5) = -1$

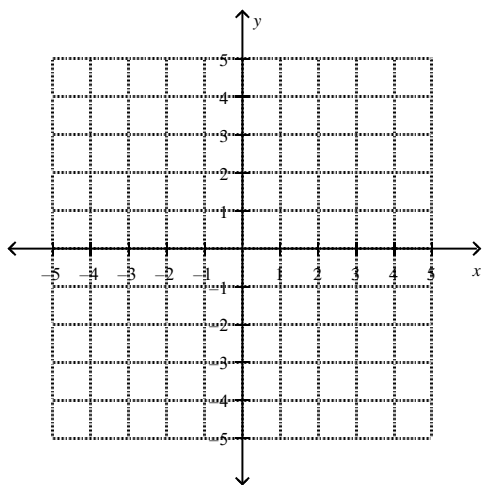

Given the function find the following coordinates and then graph the function

1. $f(x) = -2x + 4$

- a) $f(3) = 4$ b) $f(-2) =$ c) $f(-4) =$ d) $f(5) =$

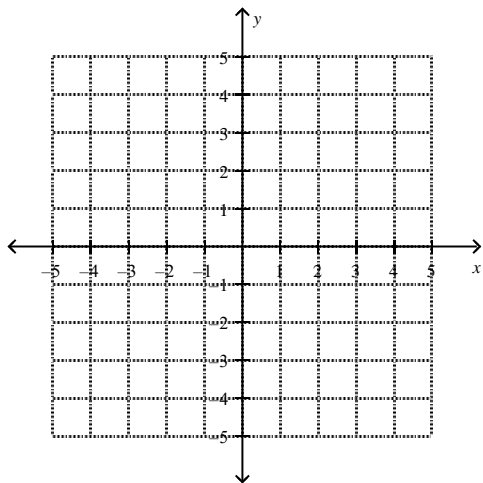

Given the function and the functions value find the following coordinates and then graph the function

1. $f(x) = -2x + 4$

a) $f(x) = 4$

b) $f(x) = -10$

c) $f(x) = -6$

d) $f(x) = 5$

Arithmetic Sequences: Function and Recursive Rules

Find the function/explicit rule from the table given below.

x	0	1	2	3	4
f(x)	9	12	15	18	21

Find the recursive rule from the table given below.

n	0	1	2	3	4
a_n	9	12	15	18	21

Find the function/explicit rule from the table given below.

x	0	1	2	3	4
f(x)	5	3	1	-1	-3

Find the recursive rule from the table given below.

n	0	1	2	3	4
a_n	5	3	1	-1	-3

Find the function/explicit rule from the table given below.

x	1	2	3	4	5
f(x)	20	15	10	5	0

Find the recursive rule from the table given below.

n	1	2	3	4	5
a _n	20	15	10	5	0

Find the function/explicit rule from the table given below.

x	1	2	3	4	5
f(x)	10	12	14	16	18

Find the function/explicit rule from the table given below.

n	1	2	3	4	5
a _n	10	12	14	16	18

Given the function rule, make a table for the values of $x = 0, 1, 2, 3, 4$

A) $f(x) = -4x + 10$

B) $f(x) = 5x - 50$

Given the recursive rule, find the first 5 terms of the sequence

A) $a_n = a_{n-1} + 3$ $a_0 = 5$

B) $a_{n+1} = a_n - 2$ $a_1 = 10$

C) $a_n = a_{n-1} + 10$ $a_0 = 10$

D) $a_{n+1} = a_n - 5$ $a_1 = 10$

Complete the table and then write the function/explicit rule and the recursive rule

Term	1st	2nd	3rd	4th	5th	6th	7th	8th
Value	66	50	34	18				

Term	1st	2nd	3rd	4th	5th	6th	7th	8th
Value	-9	-2	5	12				

Fill in the table. Then write the function/explicit rule and the recursive rule

13. You run a business making birdhouses. You spend \$600 to start your business, and it costs you \$5.00 to make each birdhouse.

# of birdhouses	1	2	3	4	5	6	7
Total cost to build							

14. You borrow \$500 from a relative, and you agree to pay back the debt at a rate of \$15 per month.

# of months	1	2	3	4	5	6	7
Amount of money owed							

16. You are saving for a bike and can save \$10 per week. You have \$25 already saved.

# of weeks	1	2	3	4	5	6	7
Amount of money saved							

Scott has decided to add push-ups to his daily exercise routine. He is keeping track of the number of push-ups he completes each day in the bar graph below, with day one showing he completed three push-ups. After four days, Scott is certain he can continue this pattern of increasing the number of push-ups he completes each day.

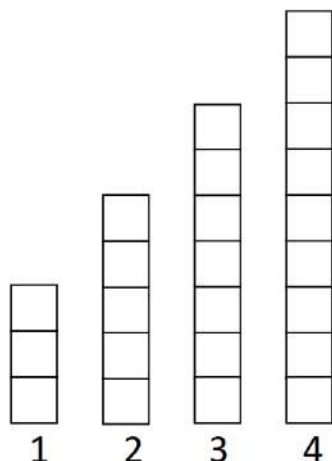

1. How many push-ups will Scott do on day 10?
2. Model the number of push-ups Scott will complete on any given day as a function/explicit rule.
3. Model the number of push-ups Scott will complete on any given day as a recursive rule.

Find the next 3 terms in each sequence. Identify the constant difference. Write a recursive function and an explicit function for each sequence. (The first number is the 1st term, not the 0th). Circle the constant difference in both functions.

4. 3, 8, 13, 18, 23, _____, _____, _____, ... Constant Difference: _____
Recursive Function: _____ Explicit Function: _____
5. 11, 9, 7, 5, 3, _____, _____, _____, ... Constant Difference: _____
Recursive Function: _____ Explicit Function: _____
6. 3, 1.5, 0, -1.5, -3, _____, _____, _____, ... Constant Difference: _____
Recursive Function: _____ Explicit Function: _____

Find the missing terms for each arithmetic sequence and state the constant difference.

1. 5, 11, ____, 23, 29, ____...

Constant Difference = _____

2. 7, 3, -1, ____, ____, -13...

Constant Difference = _____

3. 8, ____, ____, 47, 60...

Constant Difference = _____

4. 0, ____, ____, 2, $\frac{8}{3}$...

Constant Difference = _____

5. 5, ____, ____, ____, 25...

Constant Difference = _____

6. 3, ____, ____, ____, -13 ...

Constant Difference = _____

Two consecutive terms in an arithmetic sequence are given. Find the constant difference and the recursive equation.

7. If $f(3) = 5$ and $f(4) = 8$

$f(5) = \underline{\hspace{1cm}}$. $f(6) = \underline{\hspace{1cm}}$. Recursive Function: _____

8. If $f(2) = 20$ and $f(3) = 12$.

$f(4) = \underline{\hspace{1cm}}$. $f(5) = \underline{\hspace{1cm}}$. Recursive Function: _____

9. If $f(5) = 3.7$ and $f(6) = 8.7$.

$f(7) = \underline{\hspace{1cm}}$. $f(8) = \underline{\hspace{1cm}}$. Recursive Function: _____

Selling Credit Cards: Companies that offer credit cards pay the people who collect applications for those cards and the people who contact current cardholders to sell them additional financial services

How are patterns in tables of values, graphs, symbolic rules, and problem conditions for linear functions related to each other?

1. For collecting credit card applications, Barry's daily pay B is related to the number of applications he collects n by the rule $B = 5 + 10n$.

a. Use the function rule to complete this table of sample (n, B) values:

Number of Applications	0	1	2	3	4	5	10	20	50
Daily Pay (in dollars)									

b. Graph the data on a piece of graph paper.

c. i) How much will Barry earn on a day when he does not collect any credit card applications?

ii) How can this information be seen in the rule $B = 5 + 10n$?

iii) How can this information be seen In the table of sample (n, B) values?

iv) How can this information be seen In the graph?

d. i) How much additional money does Barry earn for each application he collects?

ii) How can this information be seen in the rule $B = 5 + 10n$?

iii) How can this information be seen in the table?

iv) How can this information be seen in the In the graph?

e. Write a recursive rule for the situation described above.

Cheri also works for the credit card company. She calls existing customers to sell them additional services for their account. The next table shows how much Cheri earns for selling selected numbers of additional services

Number of Services sold	10	20	30	40	50
Daily Pay (In dollars)	50	80	110	140	170

a. Does Cheri's daily pay appear to be a linear function of the number of services sold? Explain.

b. Assume that Cheri's daily pay is a linear function of the number of services she sells, and calculate the missing entries in the next table.

Number of services sold	0	10	15	20	25	30	40	50	100	101
Daily Pay (In dollars)		50		80		110	140	170		

A key feature of any function is the way the value of the dependent variable changes as the value of the independent variable changes. Notice that as the number of services Cheri sells increases from 30 to 40, her pay increases from \$110 to \$140. This is an increase of \$30 in pay for an increase of 10 in the number of services sold, or an average of \$3 per sale. Her pay increases at a *rate* of \$3 per service sold.

c. i) Using your table from Part b, study the *rate of change* in Cheri's daily pay as the number of services she sells increases by completing entries in a table like the one below.

Change in Sales	Change in Pay	Rate of change = $\frac{\Delta y}{\Delta x} = \frac{\text{Change in Pay}}{\text{Change in Sales}}$
10 to 20		
20 to 25		
25 to 40		
50 to 100		

d. Write a recursive rule for the situation

e. Write a function rule for the situation

ii. What do the numbers in the rule(s) you wrote tell you about Cheri's daily pay?

3. The diagram below shows graphs of pay plans offered by three different banks to employees who collect credit card applications.

Atlantic Bank: $A = 30 + 3n$

Boston Bank: $B = 20 + 5n$

Consumers Bank: $C = 30 + 2n$

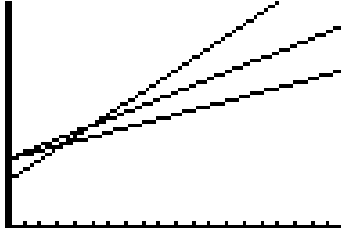

- a.** Match each function rule with its graph. Explain how you can make the matches without calculations or graphing tool help.
- b.** What do the numbers in the rule for the pay plan at Atlantic Bank tell you about the relationship between daily pay and number of credit card applications collected?
- c.** What do the numbers in the rule for the pay plan at Consumers Bank tell you about the relationship between daily pay and number of credit card applications collected?
- d.** What do the numbers in the rule for the pay plan at Boston Bank tell you about the relationship between daily pay and number of credit card applications collected?

4. Buying on Credit Electric Avenue sells audio/video, computer, and entertainment products. The store offers 0% interest for 12 months on purchases made using an Electric Avenue store credit card. Emily purchased a television for \$520 using an Electric Avenue store credit card. Suppose she pays the minimum monthly payment of \$30 each month for the first 12 months.

a. Complete a table of (*number of monthly payments, account balance*) values for the first 6 months after the purchase.

Number of Monthly Payments	0	1	2	3	4	5	6
Account Balance (in dollars)							

b. Graph the data on a piece of graph paper. **c.** Will Emily pay off the balance within 12 months?

d. Write a recursive rule for the situation above. **e.** Write a function rule for the situation above.

f. Determine the rate of change, including units, in the account balance as the number of monthly payments increases from:

Change in Sales	Change in Account Balance	Rate of change = $\frac{\Delta y}{\Delta x} = \frac{\text{Change in Pay}}{\text{Change in Sales}}$
0 to 2		
2 to 3		
3 to 6		

g. How does the rate of change reflect the fact that the account balance *decreases* as the number of monthly payments increases?

i. How can the rate of change be seen in the graph? **ii)** How can the rate of change be seen in the function rule.

iii) How can the rate of change be seen in the table.

h. What was the starting account balance for the situation?

i. How can the starting balance be seen in the graph? **ii)** How can the starting balance be seen in the table.

iii) How can the starting account balance be seen in the function rule.

5. The diagram below shows graphs of account balance functions for three Electric Avenue customers.

Emily: $E = 580 - 30m$

Darryl: $D = 460 - 50m$

Felicia: $F = 460 - 40m$

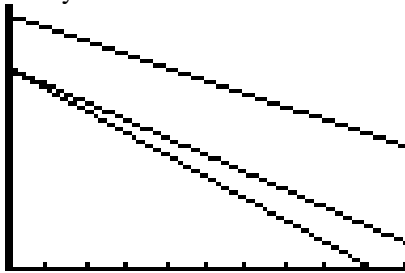

- a.** Match each function rule with its graph. Explain how you could make the matches without calculations or graphing tool help.
- b.** What do the numbers in the rules for Darryl's account balances tell you about the values of their purchases and their monthly payments?
- c.** What do the numbers in the rules for Felicia's account balances tell you about the values of their purchases and their monthly payments?
- d.** What do the numbers in the rules for Emily's account balances tell you about the values of their purchases and their monthly payments?

$$\text{slope} = \frac{\text{vertical change}}{\text{horizontal change}} \text{ or } \frac{\text{rise}}{\text{run}}$$

The steepness of the line is the ratio of rise to run, or vertical change to horizontal change, for this step. We call this ratio the **slope** of the line. Slope is also known as the rate of change.

Line With Positive Slope

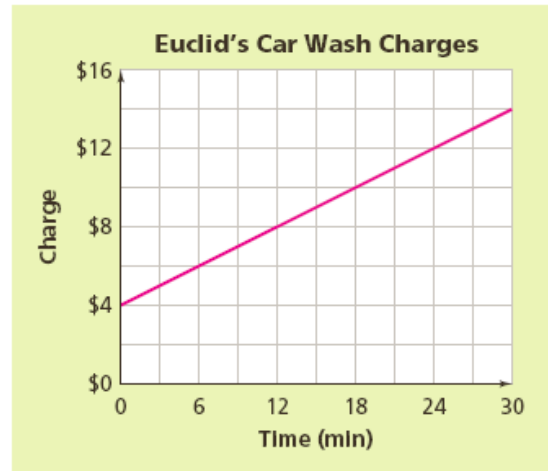
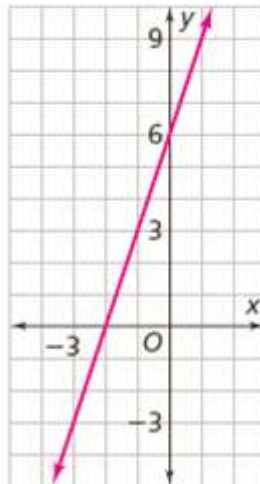
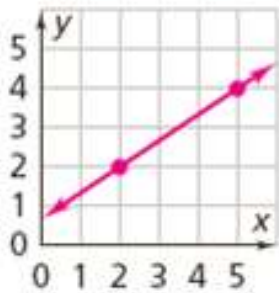

Line With Negative Slope

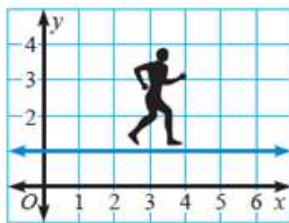
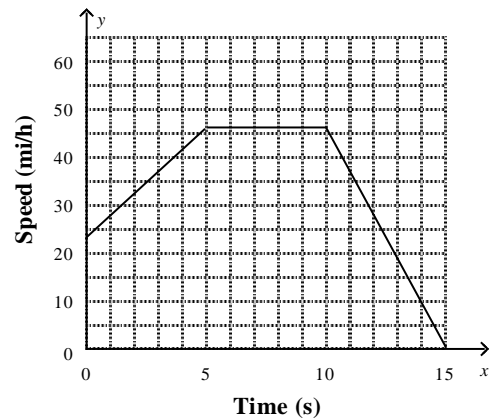
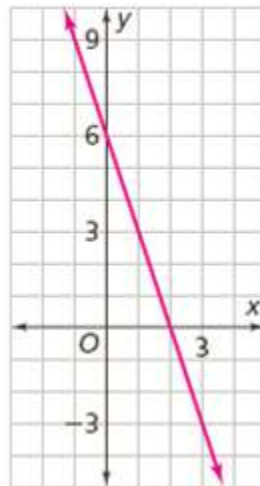
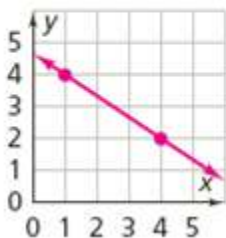

Zero slope

If the line is horizontal, the slope is *zero*.

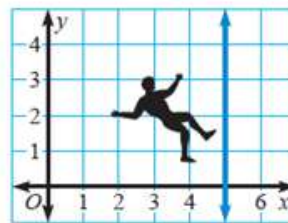

Undefined slope

If the line is vertical, the slope is *undefined*.

Positive Slope from a Table

x	2	5
y	2	4

x	-6	-4	-2	0	2	4
y	-10	-7	-4	-1	2	5

Squeaky Clean Car Wash Charges

Time (min)	5	10	15	20	25
Charge	\$8	\$13	\$18	\$23	\$28

x	y
-4	-4
-2	0
0	4
2	8

Negative Slope from a Table

x	1	4
y	4	2

x	1	2	3	4	5	6
y	4.5	4.0	3.5	3.0	2.5	2.0

x	y
5	50
10	40
15	30
20	20

X	Y
4	-10
5	-13
6	-16
7	-19
8	-22

Linear or Non-Linear Given a Table

x	5	10	15	20
y	13	28	43	58

x	3	6	9	12
y	12	10	8	6

Building	Stories	Height (ft)
Harris Bank III	35	510
One Financial Place	40	515
Kluczynski Federal Building	45	545
Mid Continental Plaza	50	582
North Harbor Tower	55	556

Source: *The World Almanac*

x	y
13	7
15	10
17	13
19	16

x	y
10	3
15	6
25	9
30	12

Time (h)	1	2	3	4
Distance (mi)	65	130	195	260

Linear or Non-Linear Given a Graph or Equation

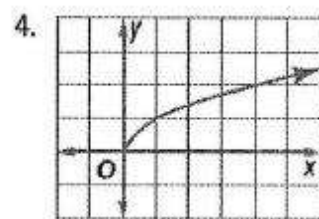
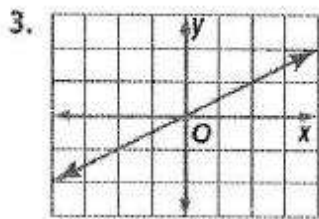
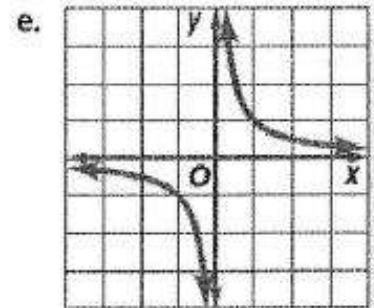
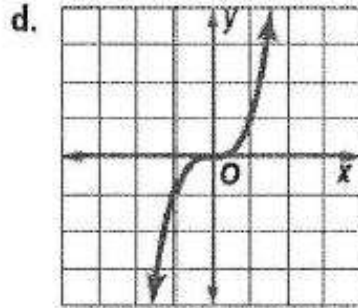
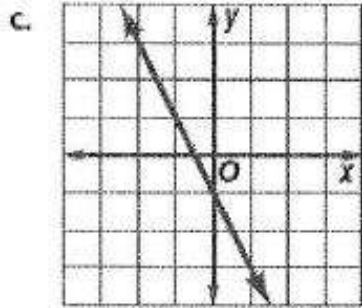

f. $y = 2x^3 + 1$

g. $y = 3x$

h. $y = \frac{x}{5}$

5. $y = \frac{x}{3}$

6. $y = 2x^2$

Find the slope of each line that passes through each pair of points

1. $A(3, 5)$ and $B(-2, 10)$

2. $A(2, -1)$ and $B(3, 2)$

3. $C(-1, 2)$ and $D(1, 1)$

4. $J(-4, 8)$, $K(-4, 4)$

5. $P(5, -7)$, $Q(-2, -7)$

A scout ant discovers that sugar has been spilled on Karen's kitchen countertop. The ant marks a straight line trail from the sugar back to the hole in the wall where ants can crawl directly onto the countertop. The sugar is 8 feet from the hole in the wall. The graph and table below describe the movement of the Ant along a path that is a straight line.

a.

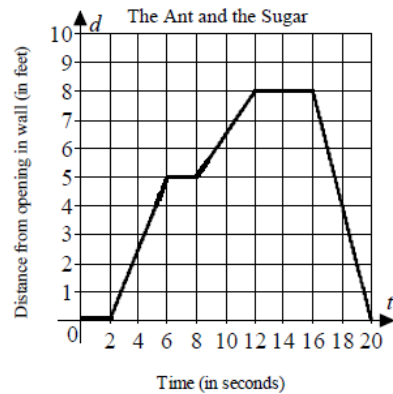

t	d(t)
0	0
2	0
6	5
8	5
12	8
16	8
18	4
20	0

2. Find the average rate of change of the Ant during the interval(s) it is heading back toward the wall.
3. At what intervals is the slope negative. What is the slope on those intervals.
4. At what intervals is the slope positive. What is the slope on those intervals.
5. At what intervals is the slope constant. What is the slope on those intervals.
6. What is the average speed of the ant on the interval $0 \leq t \leq 6$
7. What is the average speed of the ant on the interval $8 \leq t \leq 16$
8. What is the average speed of the ant on the interval $14 \leq t \leq 20$

A second ant slips through the wall onto the kitchen counter at time $t = 2$ seconds and for 8 seconds follows the trail directly to the sugar (which is 8 feet away). The ant collects sugar for 3 seconds and crawls directly back to the wall entrance. The return from the sugar to the wall takes 5 seconds.

1. Draw a graph to illustrate the story and then complete the table.

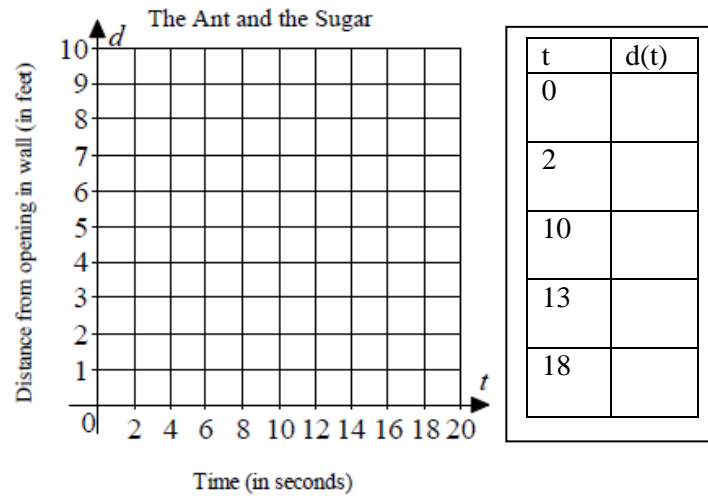

2. Find the average rate of change of the Ant during the interval(s) it is heading toward the sugar.

3. At what intervals is the slope negative. What is the slope on those intervals.

4. At what intervals is the slope positive. What is the slope on those intervals.

5. At what intervals is the slope constant. What is the slope on those intervals.

Graph the following situation:

A swimmer climbs a ladder for 3 seconds to a waterslide that is 6 feet high. She sits for 3 seconds at the top of the slide, and then slides 9 feet down the slide into the water in 3 seconds. She stayed steady at the same position underwater for 3 seconds before rising to the surface of the water in 1 second. She remained in the pool for 2 more seconds.

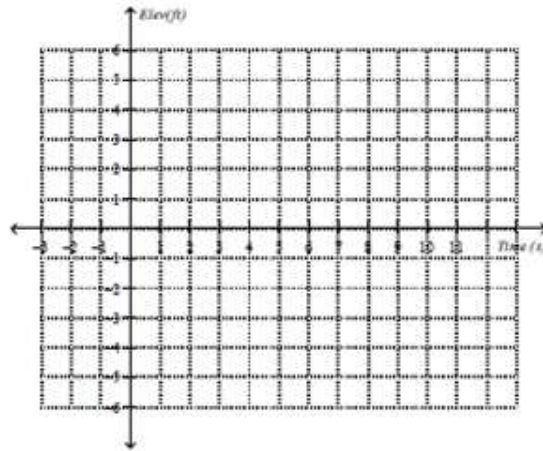

- Determine the average rate of change for the swimmer going up the ladder.
- During what time interval is the slope negative?
- At what time is the slope zero?
- Determine when the slope is positive.

The Ant and the Sugar

A scout ant discovers that sugar has been spilled on Karen's kitchen countertop. The ant marks a straight line trail from the sugar back to the hole in the wall where ants can crawl directly onto the countertop. The sugar is 8 feet from the hole in the wall. The graph and table below describe the movement of the Ant along a path that is a straight line.

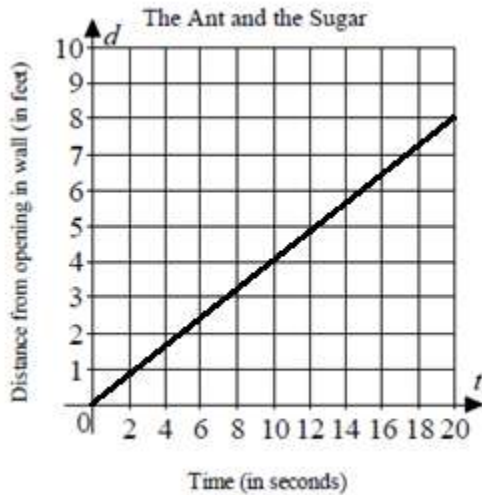

1. How far did the ant travel in 20 seconds?
2. Does the graph represent the path that the ant took during the first 20 seconds?
3. What is the Ant's average speed for the time interval $0 \leq t \leq 10$. Include units.
4. What is the Ant's average speed for the time interval $10 \leq t \leq 20$. Include units.
5. Is the Ant's average speed increasing, decreasing, or constant.

A scout ant discovers that sugar has been spilled on Karen's kitchen countertop. The ant marks a straight line trail from the sugar back to the hole in the wall where ants can crawl directly onto the countertop. The sugar is 8 feet from the hole in the wall. The graph and table below describe the movement of the Ant along a path that is a straight line.

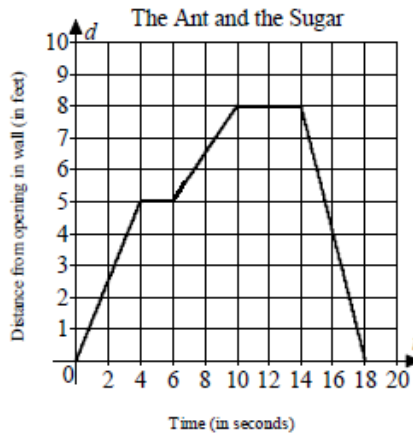

t	d(t)
0	0
4	5
6	5
10	8
14	8
16	4
18	0

1. What is the Ant's average speed for the time interval $0 \leq t \leq 18$. Include units.
2. What is the Ant's average speed for the time interval $0 \leq t \leq 5$. Include units.
3. What is the Ant's average speed for the time interval $0 \leq t \leq 10$. Include units.
4. What is the Ant's average speed for the time interval $6 \leq t \leq 8$. Include units.
5. What is the Ant's average speed for the time interval $6 \leq t \leq 14$. Include units.
6. What is the Ant's average speed for the time interval $14 \leq t \leq 18$. Include units.
7. According to the graph when was the Ant moving the fastest?
8. According to the graph when was the Ant moving the slowest?

Using the table, find the average rate of change over the following intervals.

x	$f(x)$
0	5
1	1
2	-3
3	-7
4	-11

a) from $x = 0$ to $x = 2$

b) from $x = 1$ to $x = 4$

c) from $x = 3$ to $x = 4$

Use the equations below to find the average rate of change on the given intervals

1. $y = 4x + 3$

a) $x = 0$ to $x = 2$

b) $x = 1$ to $x = 4$

c) $x = -5$ to $x = -1$

2. $y = \frac{-2}{3}x + 1$

a) $x = 0$ to $x = 2$

b) $x = 1$ to $x = 4$

c) $x = -5$ to $x = -1$

Finding the y -intercept of a line

The y -intercept is the y -coordinate of the point where a line crosses the y -axis, it's also the initial value when $x = 0$.

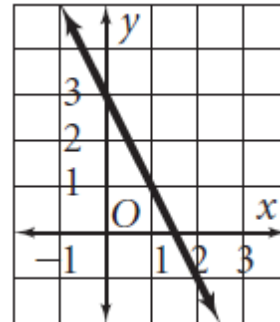
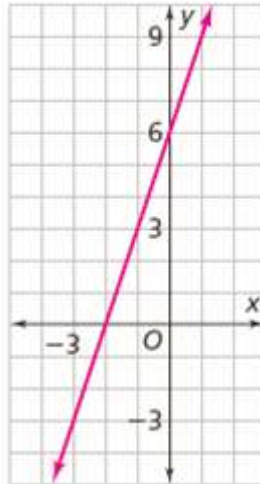
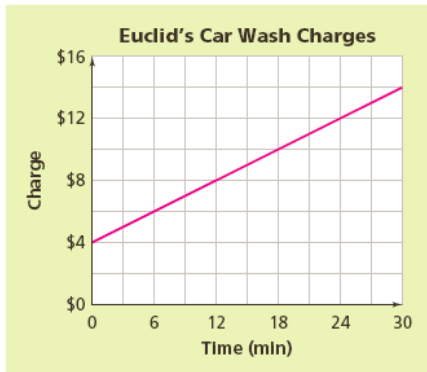

Determining the y -intercept of a table

a.

x	-6	-4	-2	0	2	4
y	-10	-7	-4	-1	2	5

b.

x	1	2	3	4	5	6
y	4.5	4.0	3.5	3.0	2.5	2.0

c.

x	y
-4	-4
-2	0
0	4
2	8

Squeaky Clean Car Wash Charges

Time (min)	5	10	15	20	25
Charge	\$8	\$13	\$18	\$23	\$28

x	y
5	50
10	40
15	30
20	20

Example 3: Slope-Intercept Form of Linear Equations:

$y = mx + b$ (m stands for slope and b stands for y-intercept)

1. $y = 4x + 7$ slope _____ y-intercept _____

2. $y = 3x - 8$ slope _____ y-intercept _____

3. $y = 6 - 7x$ slope _____ y-intercept _____

4. $y = 10x$ slope _____ y-intercept _____

5. $y = 12$ slope _____ y-intercept _____

6. Given slope of $\frac{2}{9}$ and the y-intercept is 3. _____

7. Given slope of 0 and the y-intercept is 1. _____

8. Given $m = -1$ and $b = -6$. _____

9. Given $m = -\frac{2}{3}$ and $b = 5$. _____

10. Given $m = -4$ and the y-intercept is (0, 2). _____

11. Given slope of 0.4 and $b = 0.6$ _____

Graph the linear equations: (Hint: identify the slope and y-intercept)

1. Graph: $y = \frac{1}{3}x - 2$.

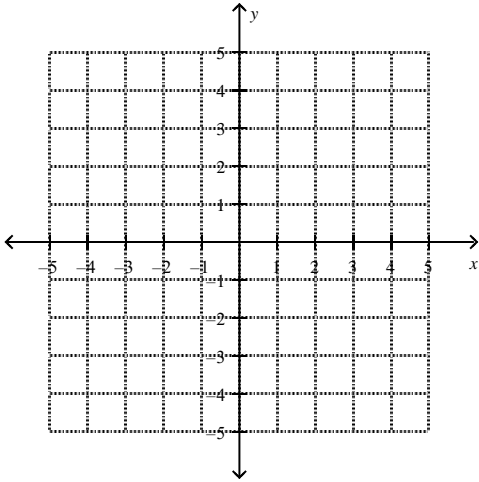

2. Graph: $y = -x + 5$.

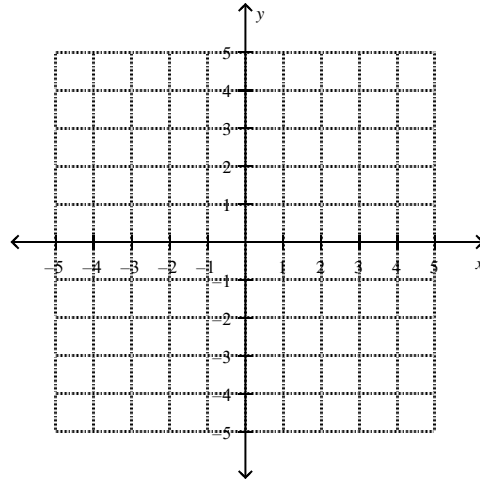

3. Graph: $y = -\frac{3}{2}x + 3$

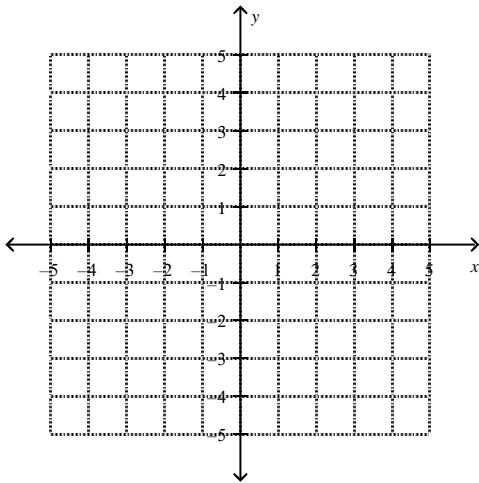

4. $y = 3x - 1$

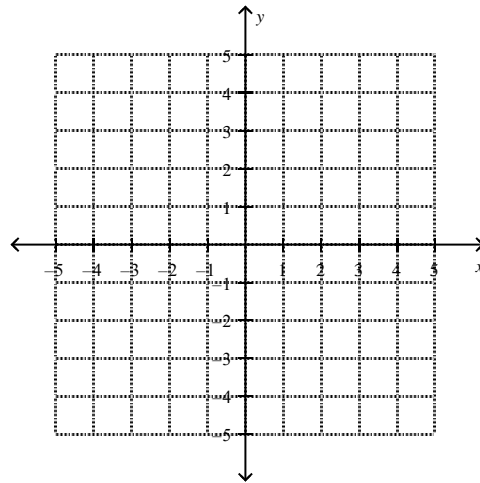

Graphing Equations by Making Tables:

1. Erika is assigned to graph the line of the equation $y = 2x - 3$.
Use Erika's equation to complete the table below for the given values of x .

x	y
-1	
1	
3	

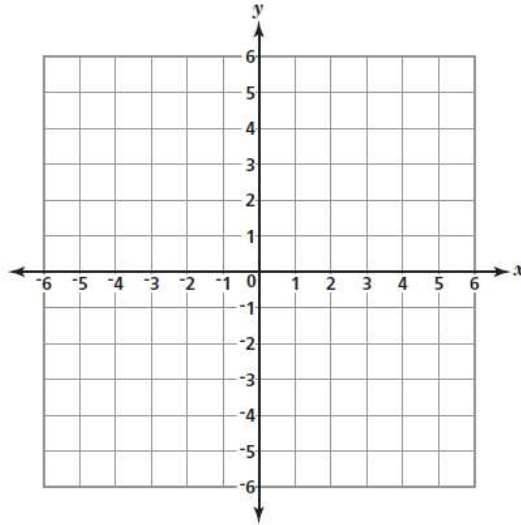

2. Ken used the function rule below to create a number pattern.

$$y = 2x + 2$$

Complete the table below using Ken's function rule.

x	y
-4	
-2	
0	
1	
3	

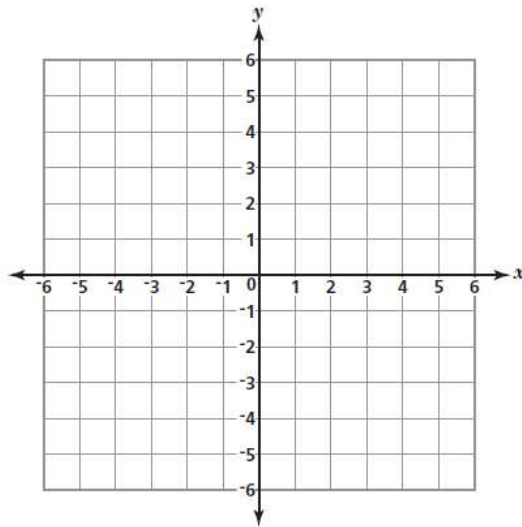

Writing Linear Equations

Use the graph to determine the linear equation.

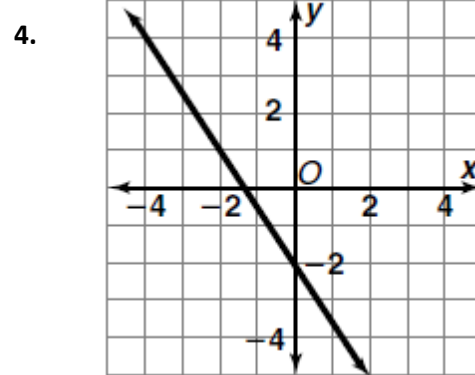
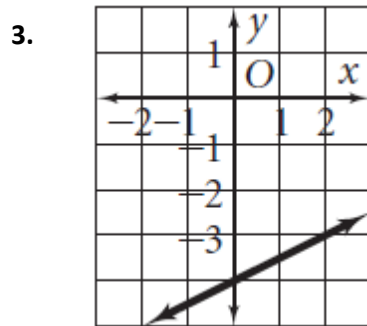
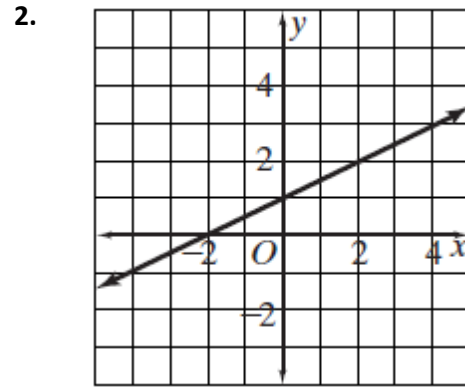
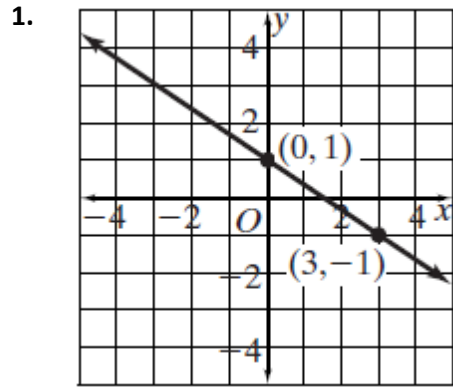

Use the table to determine the linear equation in slope-intercept form.

1.

x	y
-6	-8
-2	0
2	8

x	y
-2	-7
-1	-3
0	1
1	5

Writing Equations based on a point and slope:

Use the information provided to determine the linear equation in slope-intercept form.

1. Given $m = -\frac{1}{4}$ and the point $(-4, 2)$.

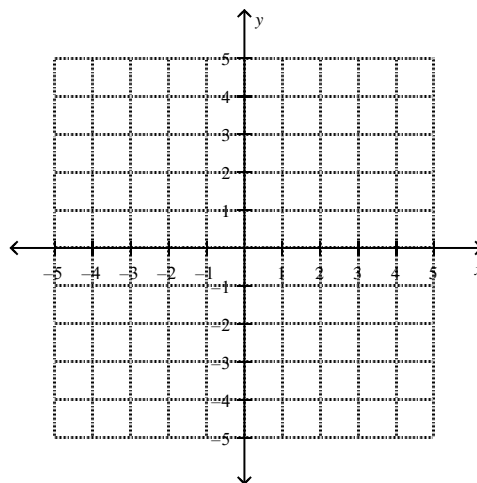

2. Given $m = \frac{3}{2}$ and the point $(-2, 0)$.

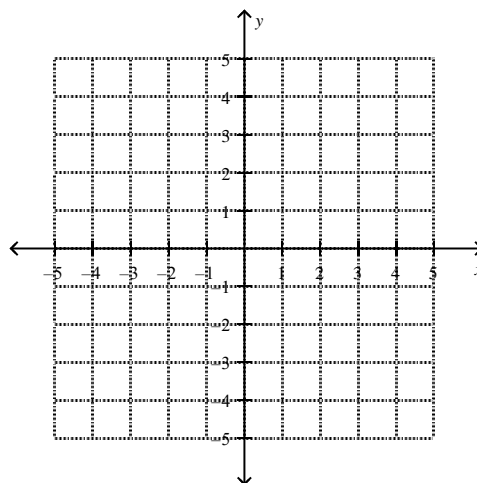

3. Given $m = 2$ and the point $(-4, -5)$.

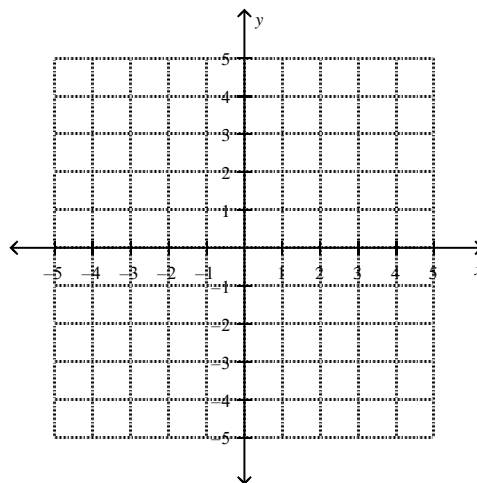

Writing Equations based on 2 points:

1. Graph a line that goes through the following 2 points, $(-3, 2)$, $(3, -2)$ and write the equation.

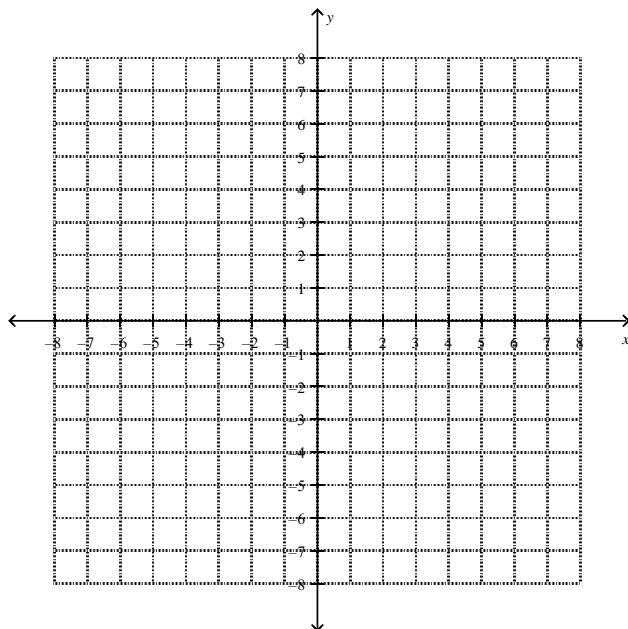

2. Graph a line that goes through the following 2 points, $(-4, -5)$, $(-3, -3)$ and write the equation.

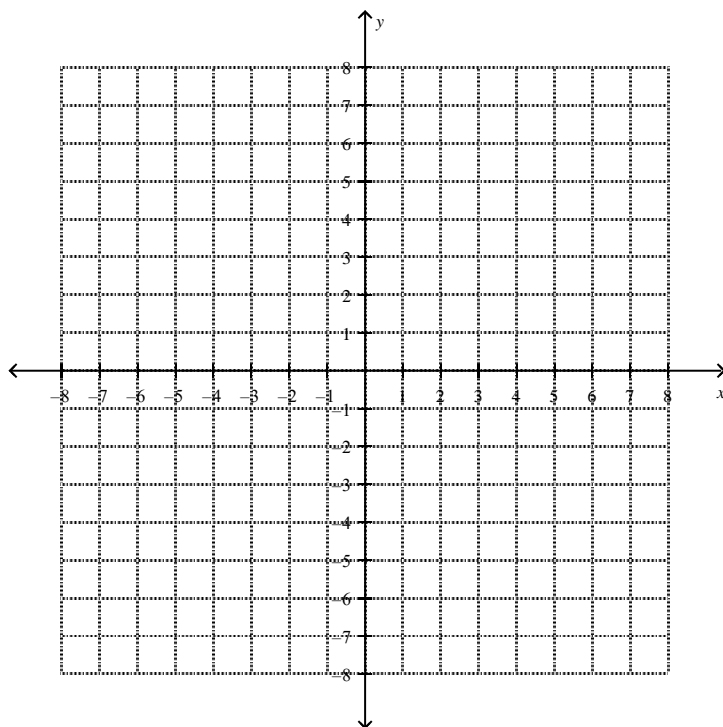

Finding Equations in point slope and slope intercept form Given 2 Points:

Use the information below to write a linear equation.

A. $(5, 3) \text{ \& } (4, 5)$

B. $(6, -4) \text{ \& } (-3, 5)$

Use the information below to write a linear equation.

A. $(2, 7) \text{ \& } (1, -4)$

B. $(6, -3) \text{ \& } (-2, -3)$

Graph each pair of lines on the same coordinate plane. Make sure you list the slope of each line.

1. $y = \frac{-1}{3}x - 2$ and $y = \frac{-1}{3}x - 4$ 2. $y = \frac{1}{4}x - 2$ and $y = \frac{1}{4}x + 1$ 3. $y = x + 2$ and $y = x - 5$

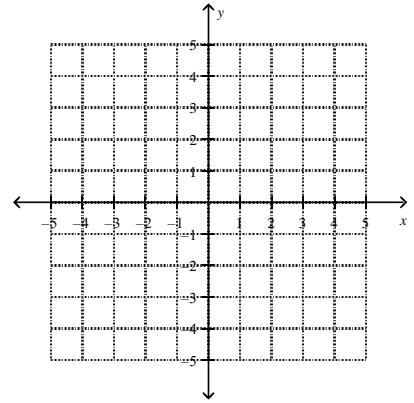
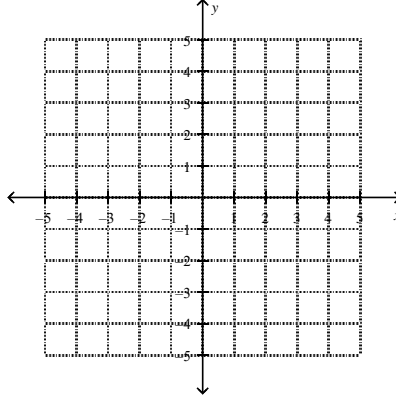
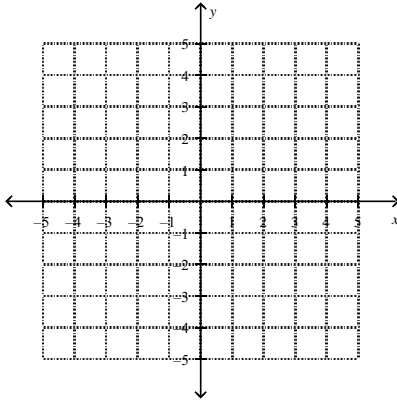

1. $y = \frac{-1}{3}x - 2$ and $y = 3x - 4$ 2. Graph $y = \frac{1}{4}x - 2$ and $y = 4x + 1$ 3. $y = -x + 2$ and $y = x - 5$

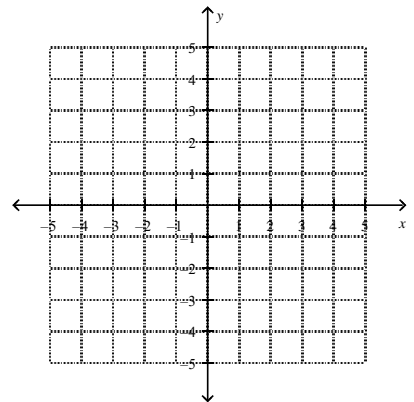
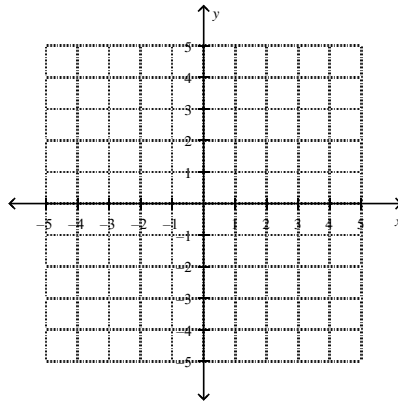
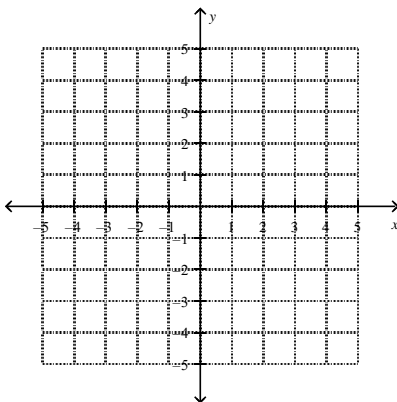

Write in point-slope form the equation of the line that is parallel to the given line and passes through the given point. Your final answer should be in slope-intercept form.

1. $y = x + 5, (-1, -1)$

2. $y = -3x + 1, (2, 4)$

3. $y = \frac{1}{4}x - 6, (3, 3)$

m = _____

m = _____

m = _____

point _____

point _____

point _____

point-slope: _____

point-slope: _____

point-slope: _____

Write in point-slope form the equation of the line that is perpendicular to the given line and passes through the given point. Your final answer should be in slope-intercept form.

1. $y = 2x + 5, (-1, -1)$

2. $y = -3x + 1, (2, 4)$

3. $y = \frac{1}{4}x - 6, (3, 3)$

m = _____

m = _____

m = _____

point _____

point _____

point _____

point-slope: _____

point-slope: _____

point-slope: _____

Write in point-slope form the equation of the line that is parallel to the given line and passes through the given point. Your final answer should be in slope-intercept form.

1. $2x + y = 4, (-1, -1)$

2. $-3x + 2y = 6, (2, 4)$

3. $5x - 2y = 10, (3, 3)$

m = _____

m = _____

m = _____

point _____

point _____

point _____

point-slope: _____

point-slope: _____

point-slope: _____

Write in point-slope form the equation of the line that is perpendicular to the given line and passes through the given point. Your final answer should be in slope-intercept form.

1. $2x + y = 4, (-1, -1)$

2. $-3x + 2y = 6, (2, 4)$

3. $5x - 2y = 10, (3, 3)$

m = _____

m = _____

m = _____

point _____

point _____

point _____

point-slope: _____

point-slope: _____

point-slope: _____

How do you use information in a table, a graph, or the conditions of a problem to write a symbolic rule for a linear function?

1. Dunking Booth Profits The student council at Eastern High School decided to rent a dunking booth for a fund-raiser. They were quite sure that students would pay for chances to hit a target with a ball to dunk a teacher or administrator in a tub of cold water. The dunking booth costs \$200 to rent for the event, and the student council decided to charge students \$0.25 per throw.

a. How do you know from the problem description that *profit* is a linear function of the *number of throws*?

b. Write a recursive rule for the dunking booth profits.

c. Write a function rule that shows how to calculate the profit P in dollars if t throws are purchased.

d. i. What do the coefficient of t and the constant term in your rule from Part c tell about: the graph of profit as a function of number of throws?

ii. What do the coefficient of t and the constant term in your rule from Part c tell about: a table of sample (*number of throws*, *profit*) values?

e. Graph the function on the graph below

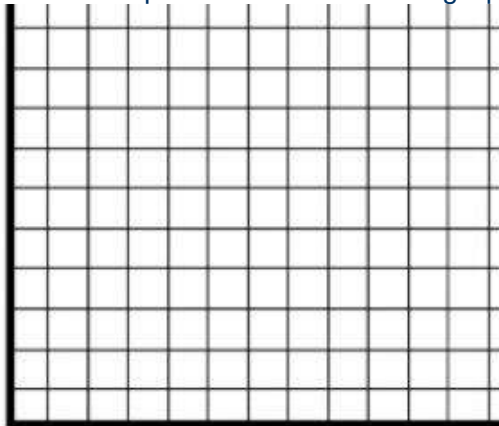

Arcade Prices : The owners of Game Time, Inc. operate a chain of video game arcades. They keep a close eye on prices for new arcade games and the resale value of their existing games. One set of predictions is the resale value of their existing games. One set of predictions is shown in the graph below.

a. Which of the linear functions in the graph predicts the future price of **classic arcade games**?



b. Which predicts the future resale value of arcade games that are **purchased now**? **i.** Find the slope and y-intercept for the classic arcade games.

Classic Arcade Games: slope = y-intercept = equation =

Games purchased now: slope = y-intercept = equation =

ii. Explain what these values tell about classic arcade game prices.

3. Turtles The Terrapin Candy Company sells its specialty—turtles made from pecans, caramel, and chocolate—through orders placed online. The company web page shows a table of prices for sample orders. Each price includes a fixed shipping-and-handling cost plus a cost per box of candy.

Number of Boxes	1	2	3	4	5	10
Price(in Dollars)	20	40	60	80	100	200

a. Explain why that price seems to be a linear function of the number of boxes ordered.

b. What is the rate of change in order price as the number of boxes increases?

c. Write a rule for calculating the price P in dollars for n boxes of turtle candies.

d. Use your rule to find the price for 6 boxes and the price for 9 boxes of turtle candies.

Mult. Representations – Car Mileage Toolkit

Name: _____

1. Your new Honda Civic car uses 1 gallon of gasoline every 25 miles. Right after filling the tank you start keeping track of how far you have driven.

- a.) Fill in the data table below and then make a graph to show the distance the truck travels on various amounts of fuel.

Start	1 gal	2 gal	3 gal	4 gal	5 gal

- b.) What is the rate of change?

- c.) Draw a graph of this relationship. Be sure to label your axes.

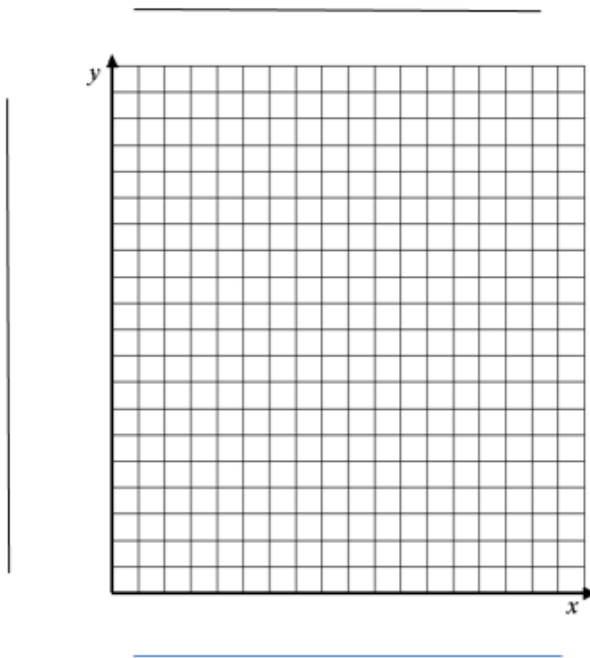

- c.) Write a " $f(x) =$ " rule for this relationship.

- d.) Check your rule against the table. Use the " $f(x) =$ " rule to find how many miles you have driven after using 4 gallons of gas.

- e.) How far have you traveled after you have used 10.5 gallons?

- f.) How many gallons does it take to drive 245 miles in your car?

- g. If your car holds 15 gallons of gasoline. Can you drive 360 miles on one tank of gas? _____ Explain Your answer.

2. Charlie purchased a new iPad mini. He borrowed the money from his parents who generously will not charge him interest. Suppose he pays his parents the same amount each month. The table below shows the account balance after each monthly payment up to 6 months.

Number of Monthly Payments	1	2	3	4	5	6
Account Balance (in dollars)	400	360	320	280	240	200

a) Make a graph of the data provided in the table. Be sure to clearly label the axes and use appropriate scales.

b) Does Charlie's account balance appear to be a linear function of the number of monthly payments Explain.

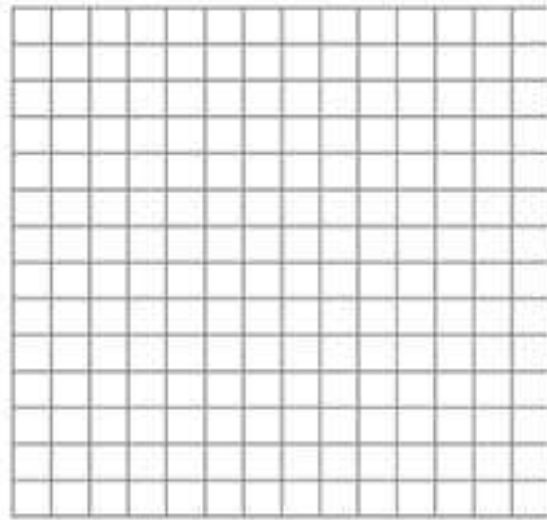

c) How much is Charlie paying each month? (this is the rate of change) _____

d) What did the iPad Mini cost? _____ How can you see this on the graph? _____

e) Write a rule that gives Charlie's balance, B , after m monthly payments have been made. _____

f) How much will Charlie's balance be after 1 **year**? _____ After 18 **months**? _____

g) When will Charlie owe only \$40? (Show your work)

Shadows On sunny days, every vertical object casts a shadow that is related to its height. The following graph shows data from measurements of flag height and shadow location, taken as a flag was raised up its pole. As the flag was raised higher, the location of its shadow moved farther from the base of the pole. Although the points do not all lie on a straight line, the data pattern can be closely approximated by a line.

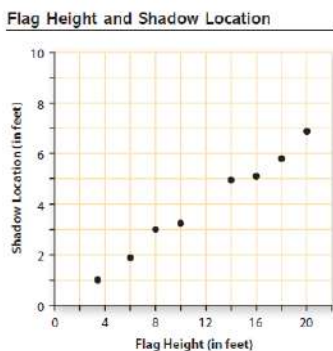

1. Consider the (*flag height, shadow location*) data plotted above.
 - a. Use a straight edge to find a line that fits the data pattern closely.
 - b. Write the rule for a function that has your line as its graph.

The line and the rule that match the (*flag height, shadow location*) data pattern are **mathematical models** of the relationship between the two variables. Both the graph and the rule can be used to explore the data pattern and to answer questions about the relationship between flag height and shadow location.

2. Use your mathematical models of the relationship between shadow
 - a. What shadow location would you predict when the flag height is 12 feet?
 - b. What shadow location would you predict when the flag height is 25 feet?
 - c. What flag height would locate the flag shadow 6.5 feet from the base of the pole?
 - d. What flag height would locate the flag shadow 10 feet from the base of the pole?

Time Flies Airline passengers are always interested in the time a trip will take. Airline companies need to know how flight time is related to flight distance. The following table shows published distance and time data for a sample of United Airlines nonstop flights to and from Chicago, Illinois. To analyze the relationship between **eastbound** flight time and flight distance, study the following scatterplot of the data on westbound flight distance and flight time.

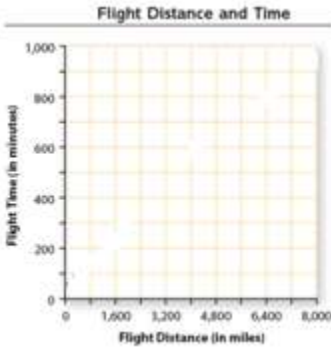

Travel Between Chicago and:	Distance (in miles)	Flight Time (in minutes)	
		Westbound	Eastbound
Boise, ID	1,435	220	190
Boston, MA	865	160	140
Cedar Rapids, IA	195	55	55
Frankfurt, Germany	4,335	550	490
Hong Kong, China	7,790	950	850
Las Vegas, NV	1,510	230	210
Paris, France	4,145	570	500
Pittsburgh, PA	410	95	85
San Francisco, CA	1,845	275	245
Tokyo, Japan	6,265	790	685

- ai. Plot the **eastbound** data and locate a line that you believe is a good model for the trend in the data.
 - a.ii. When you've located a good modeling line, write a rule for the function that has that line as its graph, using d for distance and t for time.
- b.** Explain what the coefficient of d and the constant term in the rule tell about the relationship between flight time and flight distance for **eastbound** United Airlines flights.
4. Linear models are often used to summarize patterns in data. They are also useful in making predictions. In the analysis of connections between flight time and distance, this means predicting t from d when no (d, t) pair in the data set gives the answer.
- a. United Airlines has several daily nonstop flights between Chicago and Salt Lake City, Utah—a distance of 1,247 miles. Use your linear model to predict the flight time for such **eastbound** flights.
 - b. United Airlines has several daily nonstop flights between Chicago and Denver, CO—a distance of 895 miles. Use your linear model to predict the flight time for such **eastbound** flights.

Description:

Marley spent much of his summer doing lawn care and saving his earnings in a bank account. When school started back he started withdrawing money to spend. In the table are some data from Marley's bank account.

Table: $x =$ _____

$y =$ _____

x	y
1	540
2	532
3	520
4	510
5	502
6	490
7	482
8	471
9	460
10	450

Be sure to title the graph, label each axis and use appropriate scales.

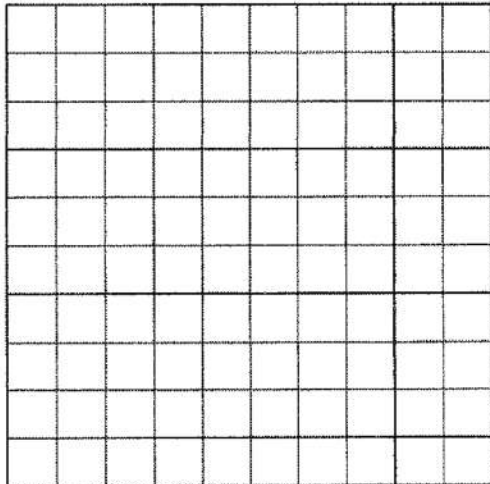

Determine a best-fit equation:

What is the y-intercept and what does it mean in context?

What is the rate of change (slope), and what does it mean in context?

Use your rule to predict how long it took Marley to reach \$25.00 in his account.