

# Progress Update

February 2018



## Guiding Principles:

1. **S:** (safety/security): single entry point, access control, fencing
2. **T:** (technology): 21<sup>st</sup> century upgrades and furnishings
3. **E:** (evolution): modernization, preppy K, 'maker' labs
4. **M:** (maintenance): roofing, HVAC, phones, playgrounds
5. **P:** (parity): portable replacement, child care
6. **S:** (sustainability): solar panels, EMS, irrigation systems

## Proposed Actions:

1. **New construction:** "Build something we don't have."
2. **Modernization/Renovation:** "Repurpose something we do have."
3. **Site and grounds:** "Play fields, parking lots, playgrounds, fencing."
4. **Furniture, technology and systems:** "Update the instructional program to align with 21<sup>st</sup> century learning styles and practices."

## Progress Update

February 2018



# Measure H Time Line:

- July 2016 Master Plan Adoption
- November 2016 Measure H Ballot Measure
- December 2017 County Certification
- January 2017 Implementation Plan Adoption

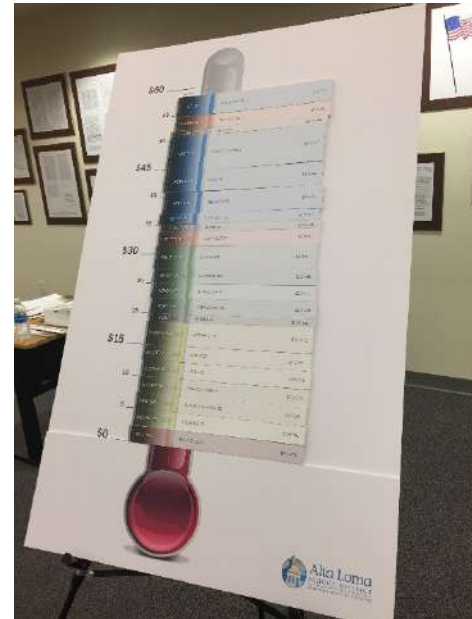

# Progress Update

February 2018



# Progress Update

February 2018

## West Side Schools:

## East Side Schools:



# Measure H Time Line:

## Progress Update

February 2018

Spring 2017

### Modernization Kick-Off

Site Tours / Faculty Input  
Site Surveys and Utility Investigations  
Technology Network Bids



Summer 2017

### Modernization Design Development Documents

Technology Network Installation  
Security Package Planning  
*Deer Canyon Addition Construction Documents*

Fall 2017

### Modernization Construction Documents

Security Package Bids  
*Deer Canyon Addition DSA Submission*



# Measure H Time Line:

## Progress Update

February 2018

'Winter' 2018

**Modernization DSA Submission**  
Security Package Award and Installation  
*Deer Canyon Addition DSA approval*

Spring 2018

**Modernization DSA Plan Check**  
Security Package Installation

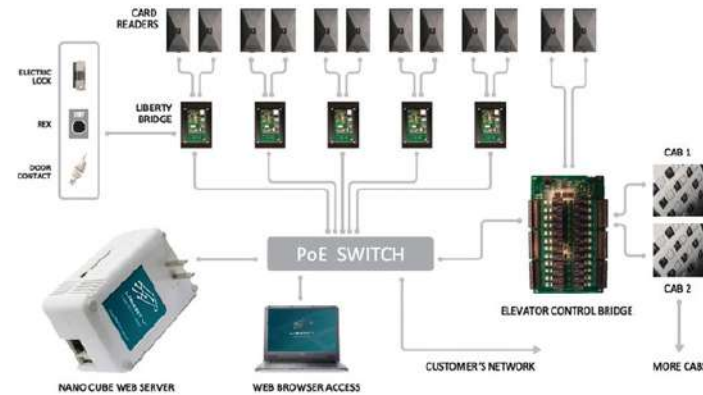

Summer 2018

**Modernization DSA Approval**  
Modernization Bid Process  
State Funding Applications  
*Deer Canyon Addition Construction Begins*

Fall 2018

**Modernization Construction Begins**



# East Side Master Site Diagrams:

Progress Update  
February 2018



Deer Canyon  
Hermosa  
Victoria Groves  
Elementary Schools



# Deer Canyon Classroom Wing Addition:

Progress Update  
February 2018

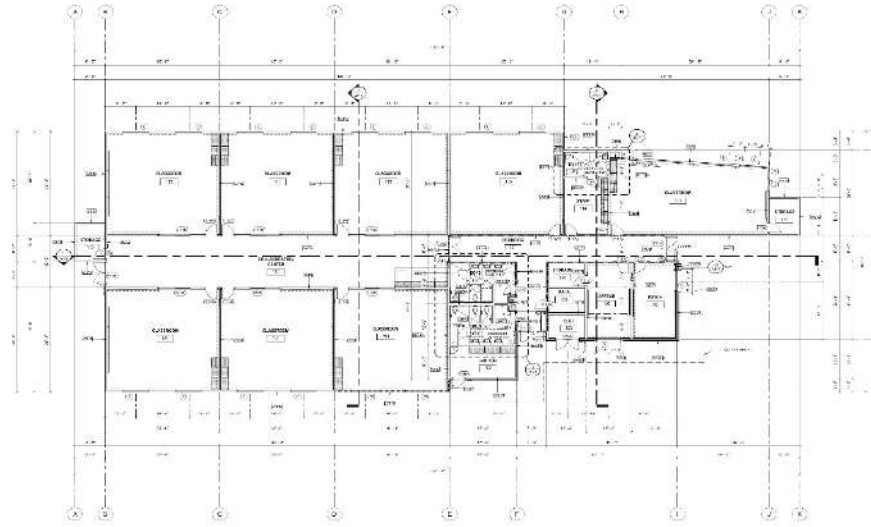



# East Side Modernization Scope of Work:

## All Classrooms (including Kindergarten):

- Provision for wall mounted short throw projector
- New tack-able wall board on all 4 walls
- Paint ceiling grid, all new tiles or paint glue-up tile
- New flooring with walk-off mat at exterior doors
- New plastic laminate cabinetry & countertops
- Replace bubbler sink
- New tubular skylights in each classroom
- New recessed fire extinguisher cabinet and fire extinguisher

## All Restrooms (student and staff):

- Update to comply with current code
- New full height wall tile
- New floor tile
- Paint ceiling
- New plumbing fixtures & toilet accessories

## Roof:

- Re-seal at all sites, replace gutters & flashing
- Replace all sheet metal roofing (Victoria Groves)

## Electrical:

- Update all lighting fixtures to LED
- Update Fire Alarm system

## Plumbing:

- New hi-lo ADA drinking fountains & all new restroom and classroom plumbing fixtures

## Mechanical (HVAC) (Victoria Groves):

- Replace all roof-top units & exhaust fans

## Reception/ Lobby (Only at Hermosa and Deer Canyon)

- Update with new layout and cabinetry
- Update flooring & wall finishes

# Progress Update

February 2018



# East Side Master Site Diagram:

# Progress Update

February 2018

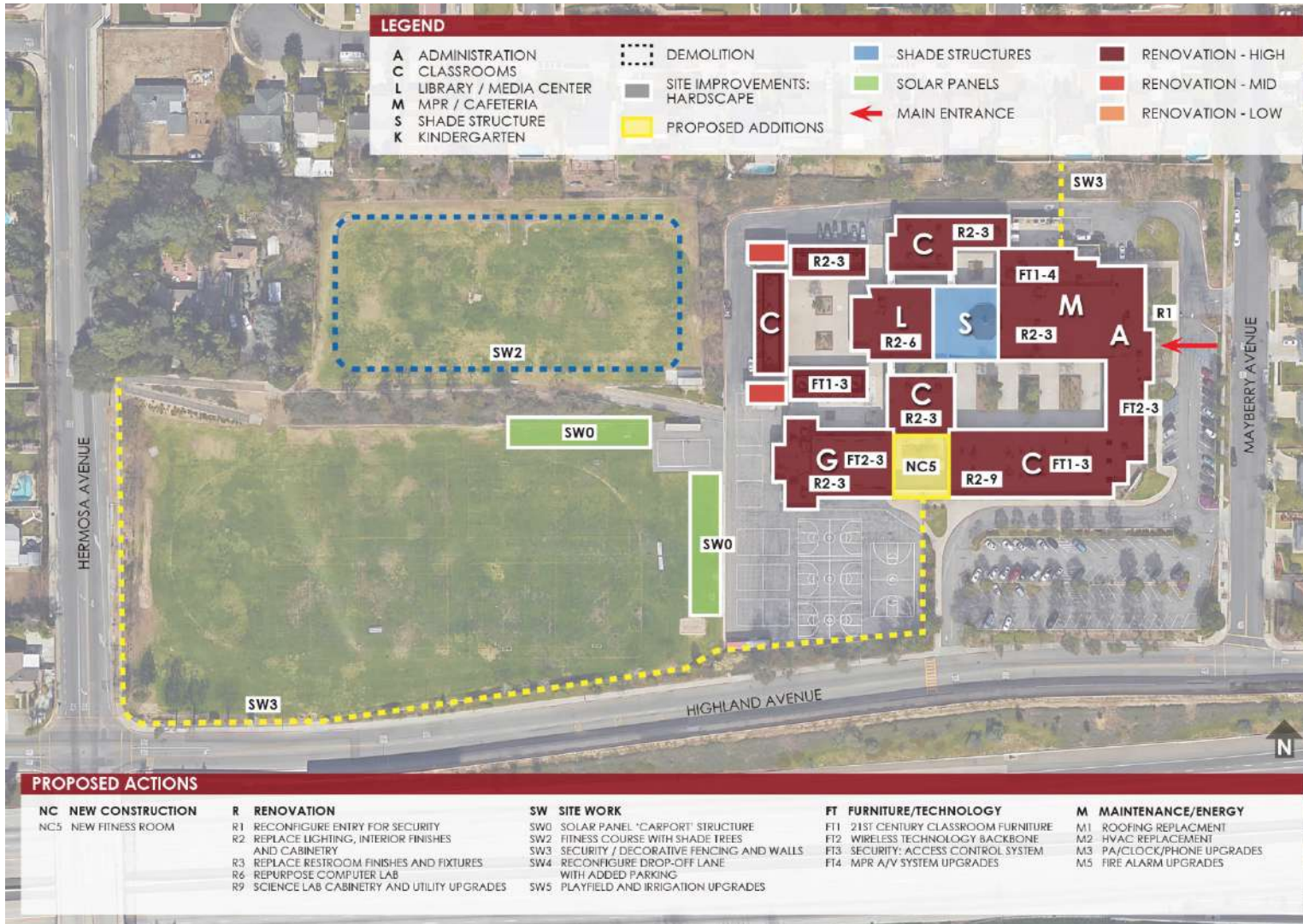

Vineyard Junior High School



# East Side Modernization Scope of Work:

## VINEYARD JHS (unique scope):

### **Science Labs:**

- New cabinets with epoxy resin sink and countertops
- Update layout with sink & utilities along wall for flexible lab concept
- Floor, wall, ceiling & tubular skylight update same as typical classroom

### **Band /Choir:**

- Floor, wall ceiling & tubular skylight update same as typical classrooms

### **Roofing:**

Cover wood shake roofing with sheet metal roofing.

### **Mechanical (HVAC)**

- Replace all roof-top units & exhaust fans

### **Reception/ Lobby:**

- Update with new layout and cabinetry
- Update flooring & wall finish

# Progress Update

February 2018

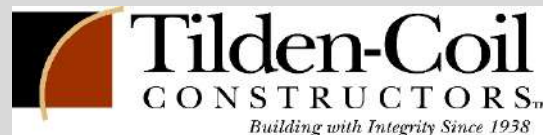

# East Side Master Site Diagram:

# Progress Update

February 2018

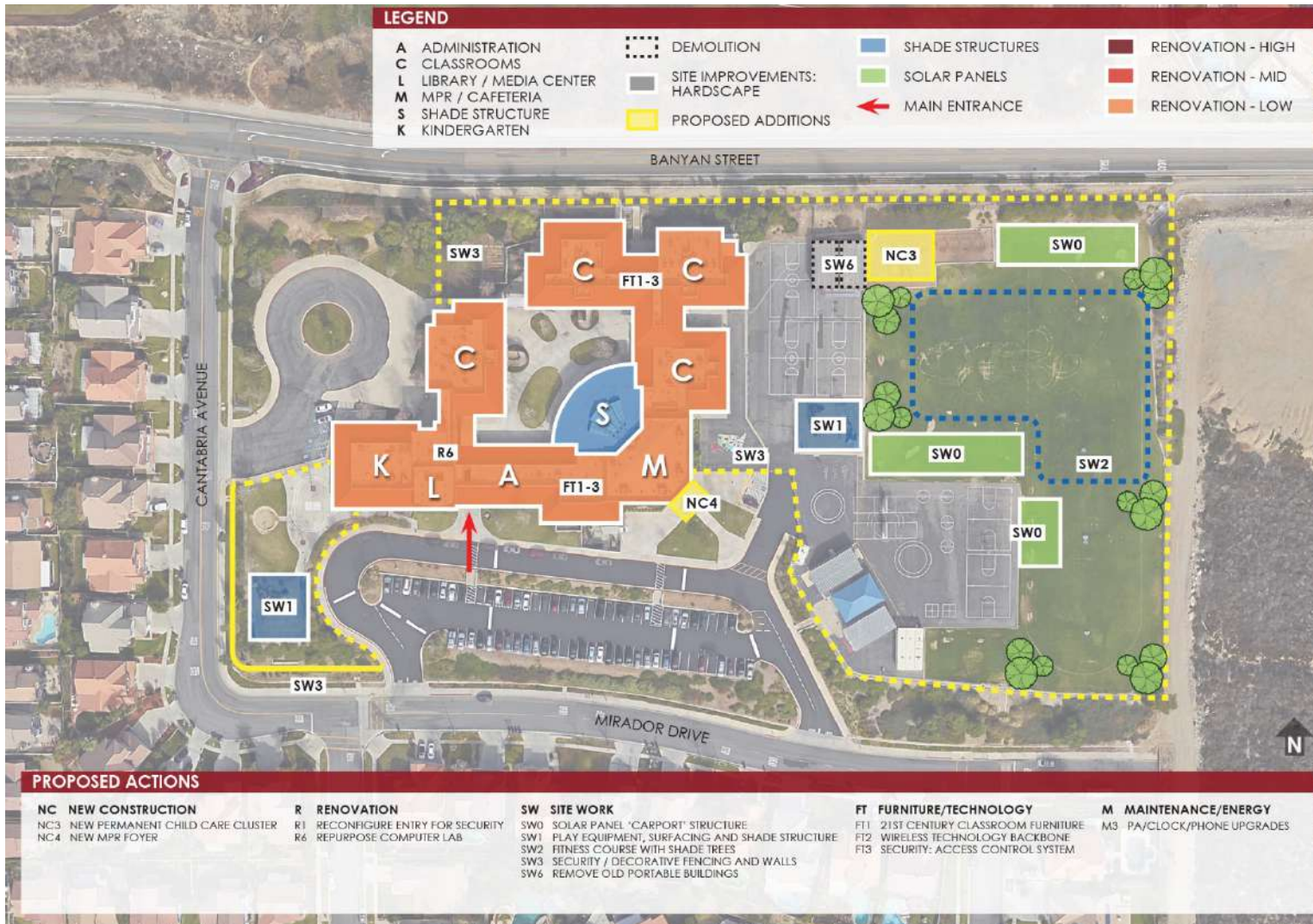

Banyan Elementary School



# East Side Modernization Scope of Work:

### **BANYAN ES (unique scope):**

#### **All Classrooms:**

- Provision for wall mounted short throw projector
- New Tack-able wall board on all 4 walls
- Paint ceiling grid and replace some ceiling tiles
- New walk-off mats at exterior doors
- New, recessed fire extinguisher cabinets and fire extinguisher
- NO tubular skylights

#### **All Restrooms: (student and staff):**

- Minor updates to comply with current code
- New full height wall tile where work occurs
- New floor tile where work occurs
- Paint ceiling
- New plumbing fixtures & toilet accessories

#### **Kindergarten Classrooms:**

- New water closet only and modify existing area for ADA compliance and new wall and/or wall tiles as required

#### **Roof:**

- Re-seal, replace gutter & flashing

#### **Electrical:**

- Update all lighting fixtures to LED
- Update FA system

#### **Plumbing:**

- New plumbing fixtures in classroom and restrooms where other work occurs



# West Side Master Site Diagrams

Progress Update  
February 2018



Alta Loma Elementary School



Carnelian Elementary School



Jasper Elementary School



Stork Elementary School

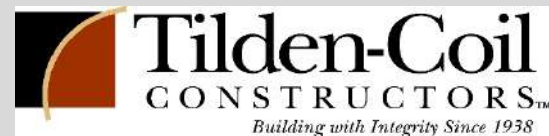

# West Side Modernization Scope of Work:

## **ALTA LOMA ELEMENTARY SCHOOL**

All Classrooms in Buildings "D", "E", "F", "G" and "H":

- New flooring with walk-off mat at exterior doors
- Provision for wall mounted short throw projector (backbox and infrastructure only)
- Patching, repairing and painting walls and ceilings
- Replacement of tack board and marker board panels
- Replacement of some glazing with insulated metal panels

Staff and Student Restrooms in Buildings "D", "E", "F" and "H":

- Update to comply with current Code
- Patching, repairing and painting ceilings
- Patching and repairing walls and floor finishes (Building "D" only)

Electrical:

- New pendant mount LED light fixtures in the Classrooms (Buildings "D", "E", "F", "G" and "H")
- Fire Alarm upgrades (campus wide)

Plumbing:

- New hands-free faucets and flush valves (Building "H" only)
- Replace restroom fixtures (Building "D" only)

Mechanical:

- Modification of HVAC ducting in the Classrooms (Buildings "D", "E", "F", and "G")
- HVAC units' replacement in Buildings "D", "E", "F", "G" and "H"

Roofing:

- Complete re-roof (Buildings "D", "E", "F", "G" and "H")
- Replace gutters and flashing (Buildings "D", "E", "F", "G" and "H")

Site Improvements:

- Path of Travel upgrades for Code compliance
- Replacement of domestic water supply lines to Buildings

## Progress Update

February 2018



# West Side Modernization Scope of Work:

## Progress Update

February 2018

### CARNELIAN ELEMENTARY SCHOOL

All Classrooms in Buildings "C", "G" and "H":

- New flooring with walk-off mat at exterior doors
- Provision for wall mounted short throw projector (backbox and infrastructure only)
- New Solar Tube skylights
- Patching, repairing and painting walls and ceilings
- Replacement of some of the existing wall finish with tack-able wall board over furring

Staff and Student Restrooms in Buildings "C", "G" and "H":

- Update to comply with current Code
- Patching, repairing and painting ceilings
- Patching and repairing walls and floor finishes (Buildings "C" and "G")

Electrical:

- New pendant mount LED light fixtures in the Classrooms (Buildings "C", "G" and "H")
- Fire Alarm Upgrades (campus wide)

Plumbing:

- New hands-free faucets and flush valves (Building "H" only)
- Replace plumbing fixtures at Staff Restrooms (Buildings "C" and "G")

Mechanical:

- HVAC units' replacement in Buildings "C", "G" and "H"

Roofing:

- Re-seal and re-coat roof membrane (Buildings "C" and "G")
- Repair roof membrane (Building "H")
- Replace leaking gutters (Buildings "C", "G" and "H")

Site Improvements:

- Path of Travel upgrades for Code compliance
- Replacement of campus sewer and water lines





# West Side Modernization Scope of Work:

## **STORK ELEMENTARY SCHOOL**

### All Classrooms:

- Replacement of some operable partitions with permanent walls (Pods "200", "300", "400" and "500")
- New flooring with walk-off mat at exterior doors
- Provision for wall mounted short throw projector (backbox and infrastructure only)
- New Solar Tube skylights
- New plastic laminate cabinetry and countertops
- Replace bubbler sink
- Patching, repairing and painting walls and ceilings
- New Tack Board and Marker Boards

### Student Restrooms in Pod "100":

- New floor drains
- New floor finish
- Patching, repairing and painting walls and ceilings

### Staff and Student Restrooms in Pods "300" and "500":

- Update to comply with current Code
- New wall and floor finishes
- Patching, repairing and painting ceilings
- New plumbing fixtures and toilet accessories

### Staff and Student Restrooms in Pod "400":

- Patching, repairing and painting walls and ceilings

### MPR:

- Patching, repairing and painting walls and ceilings
- New Solar Tube skylights

### LIBRARY:

- Interior renovation
- New flooring
- Patching, repairing and painting walls and ceilings
- New Solar Tube skylights

### Electrical:

- Update all Classroom light fixtures to LED
- Lighting upgrades in the Library, and Staff and Student Restrooms in Pods "300" and "500"
- Fire Alarm upgrades (campus wide)

### Plumbing:

- New hi-lo ADA drinking fountain
- New Restroom and Classroom plumbing fixtures

### Mechanical:

- HVAC ducting renovation in Classrooms
- New HVAC System for existing MPR space behind Library

### Roofing:

- Re-seal and re-coat roof membrane

### Site Improvements:

- Path of Travel upgrades for Code compliance

## Progress Update

February 2018



# West Side Modernization Scope of Work:

## **JASPER ELEMENTARY SCHOOL**

### All Classrooms:

- Replacement of some operable partitions with permanent walls (Pods "200", "300", "400" and "500")
- New flooring with walk-off mat at exterior doors
- Provision for wall mounted short throw projector (backbox and infrastructure only)
- New Solar Tube skylights
- New plastic laminate cabinetry and countertops
- Replace bubbler sink
- Patching, repairing and painting walls and ceilings
- New Tack Board and Marker Boards

### Student Restrooms in Pod "100":

- New floor drains
- New floor finish
- Patching, repairing and painting walls and ceilings

### Staff and Student Restrooms in Pod "300":

- Patching, repairing and painting walls and ceilings

### Staff and Student Restrooms in Pod "400":

- Update to comply with current Code
- New wall and floor finishes
- Patching, repairing and painting ceilings
- New plumbing fixtures and toilet accessories

### MPR:

- Patching, repairing and painting walls and ceilings
- New Solar Tube skylights

### LIBRARY:

- Interior renovation
- New flooring
- Patching, repairing and painting walls and ceilings
- New Solar Tube skylights

### Electrical:

- Update all classroom light fixtures to LED
- Lighting upgrades in the Library, and Staff and Student Restrooms in Pod "400"
- Fire Alarm Upgrades (campus wide)

### Plumbing:

- New hi-lo ADA drinking fountain
- New Restroom and Classroom plumbing fixtures

### Mechanical:

- HVAC ducting upgrade in Classrooms
- New HVAC System for existing MPR space behind Library

### Roof:

- Re-seal and re-coat roof membrane

### Site Improvements:

Path of Travel upgrades for Code compliance

## Progress Update

February 2018



# West Side Master Site Diagram:

# Progress Update

February 2018

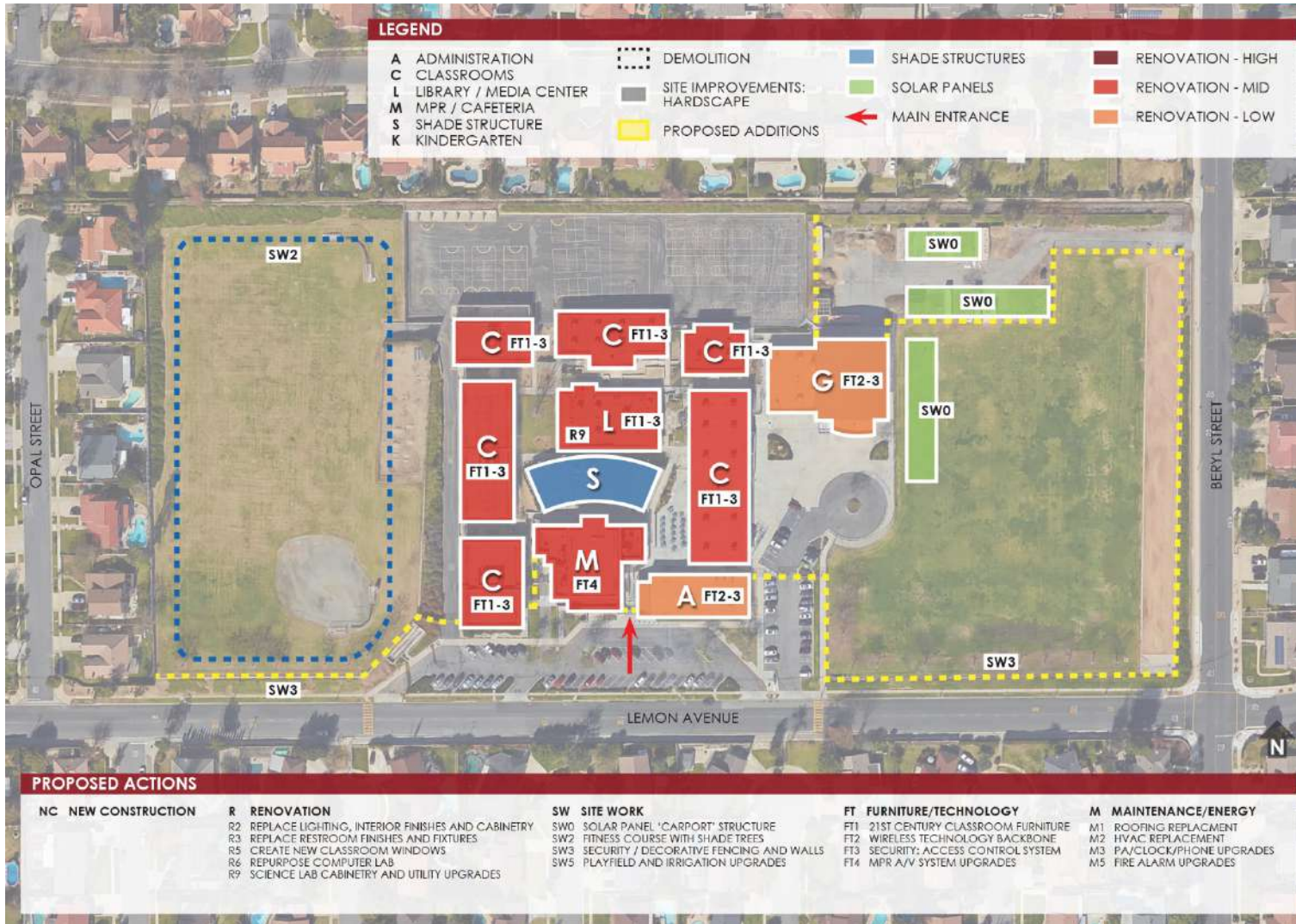

Alta Loma Junior High School



# West Side Modernization Scope of Work:

## **ALTA LOMA JUNIOR HIGH SCHOOL**

All Classrooms in Buildings "C", "D", "E", "G" and "H":

- New plastic laminate cabinetry and countertops
- Interior renovations
- Replacement of some of the existing wall finish with tack-able wall board over furring
- New windows (Building "C" only)
- Structural upgrades at Choral Room (Building "C" only)
- New sinks (Buildings "C" and "E")
- New epoxy countertops and sinks (Buildings "G" and "H")

All Classrooms in Buildings "C", "D", "E", "F", "G", "H" and "J/K":

- New flooring with walk-off mat at exterior doors
- Patching, repairing and painting walls and ceilings
- Provision for wall mounted short throw projector (backbox and infrastructure only)
- New Solar Tube skylights
- Replacement of tack board and marker board panels

Staff and Student Restrooms in Building "D":

- Update to comply with current Code
- New wall and floor finishes
- Patching, repairing and painting ceilings
- New plumbing fixtures and toilet accessories

Staff and Student Restrooms in Building "J/K":

- Update to comply with current Code
- New toilet partitions
- Patching, repairing and painting walls and ceilings

Electrical:

- Update all classroom light fixtures to LED
- Lighting upgrades (Buildings "C", "E" and "H")
- Fire Alarm upgrades (campus wide)

Plumbing:

- New Restroom and Classroom plumbing fixtures
- New water, air and gas lines to new and renovated Science Classrooms (Buildings "G" and "H")

Mechanical:

- Modification of HVAC ducting in the Classrooms (Buildings "C", "D", "E", "G", "H" and "J/K")
- New HVAC roof top units (Buildings "B", "J/K")

Roof:

- Re-seal and re-coat roof membrane (Buildings "B", "C", "D", "E", "G", "H" and "J/K")
- Replace leaking gutters (Buildings "B", "C", "D", "E", "G", "H" and "J/K")

Site Improvements:

- Path of Travel upgrades for Code compliance
- Exterior painting (campus wide)

## Progress Update

February 2018



# Progress Update

February 2018

