

Geometry

Administered May 2013

RELEASED

STAAR GEOMETRY REFERENCE MATERIALS

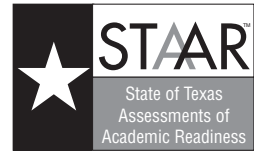

CIRCUMFERENCE

Circle $C = 2\pi r$ or $C = \pi d$

AREA

Triangle $A = \frac{1}{2}bh$

Rectangle or parallelogram $A = bh$

Rhombus $A = \frac{1}{2}d_1d_2$

Trapezoid $A = \frac{1}{2}(b_1 + b_2)h$

Regular polygon $A = \frac{1}{2}aP$

Circle $A = \pi r^2$

SURFACE AREA

	Lateral	Total
Prism	$S = Ph$	$S = Ph + 2B$
Pyramid	$S = \frac{1}{2}Pl$	$S = \frac{1}{2}Pl + B$
Cylinder	$S = 2\pi rh$	$S = 2\pi rh + 2\pi r^2$
Cone	$S = \pi rl$	$S = \pi rl + \pi r^2$
Sphere		$S = 4\pi r^2$

VOLUME

Prism or cylinder $V = Bh$

Pyramid or cone $V = \frac{1}{3}Bh$

Sphere $V = \frac{4}{3}\pi r^3$

STAAR GEOMETRY REFERENCE MATERIALS

COORDINATE GEOMETRY

Midpoint

$$\left(\frac{x_1 + x_2}{2}, \frac{y_1 + y_2}{2} \right)$$

Distance formula

$$d = \sqrt{(x_2 - x_1)^2 + (y_2 - y_1)^2}$$

Slope of a line

$$m = \frac{y_2 - y_1}{x_2 - x_1}$$

Slope-intercept form of a linear equation

$$y = mx + b$$

Point-slope form of a linear equation

$$y - y_1 = m(x - x_1)$$

Standard form of a linear equation

$$Ax + By = C$$

RIGHT TRIANGLES

Pythagorean theorem

$$a^2 + b^2 = c^2$$

Trigonometric ratios

$$\sin A = \frac{\text{opposite leg}}{\text{hypotenuse}}$$

$$\cos A = \frac{\text{adjacent leg}}{\text{hypotenuse}}$$

$$\tan A = \frac{\text{opposite leg}}{\text{adjacent leg}}$$

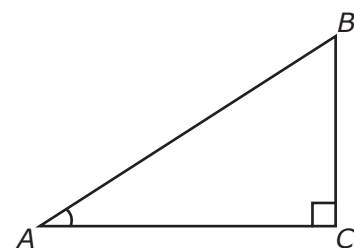

30° - 60° - 90° triangle

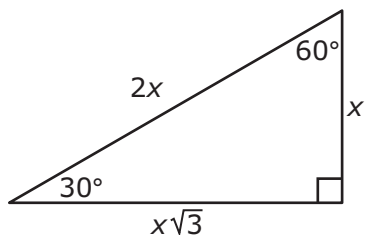

45° - 45° - 90° triangle

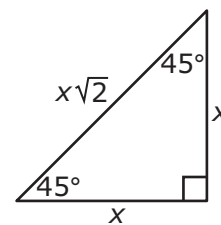

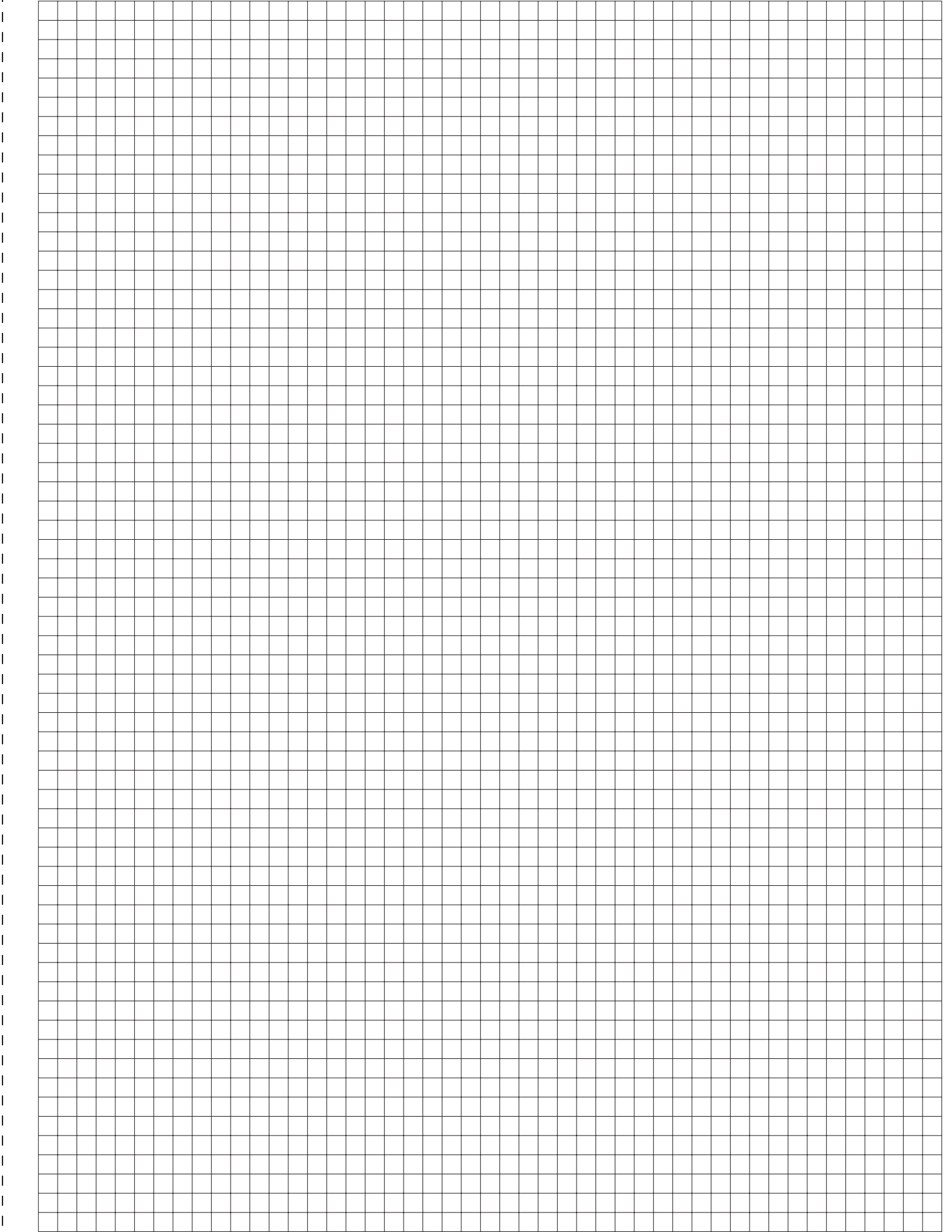

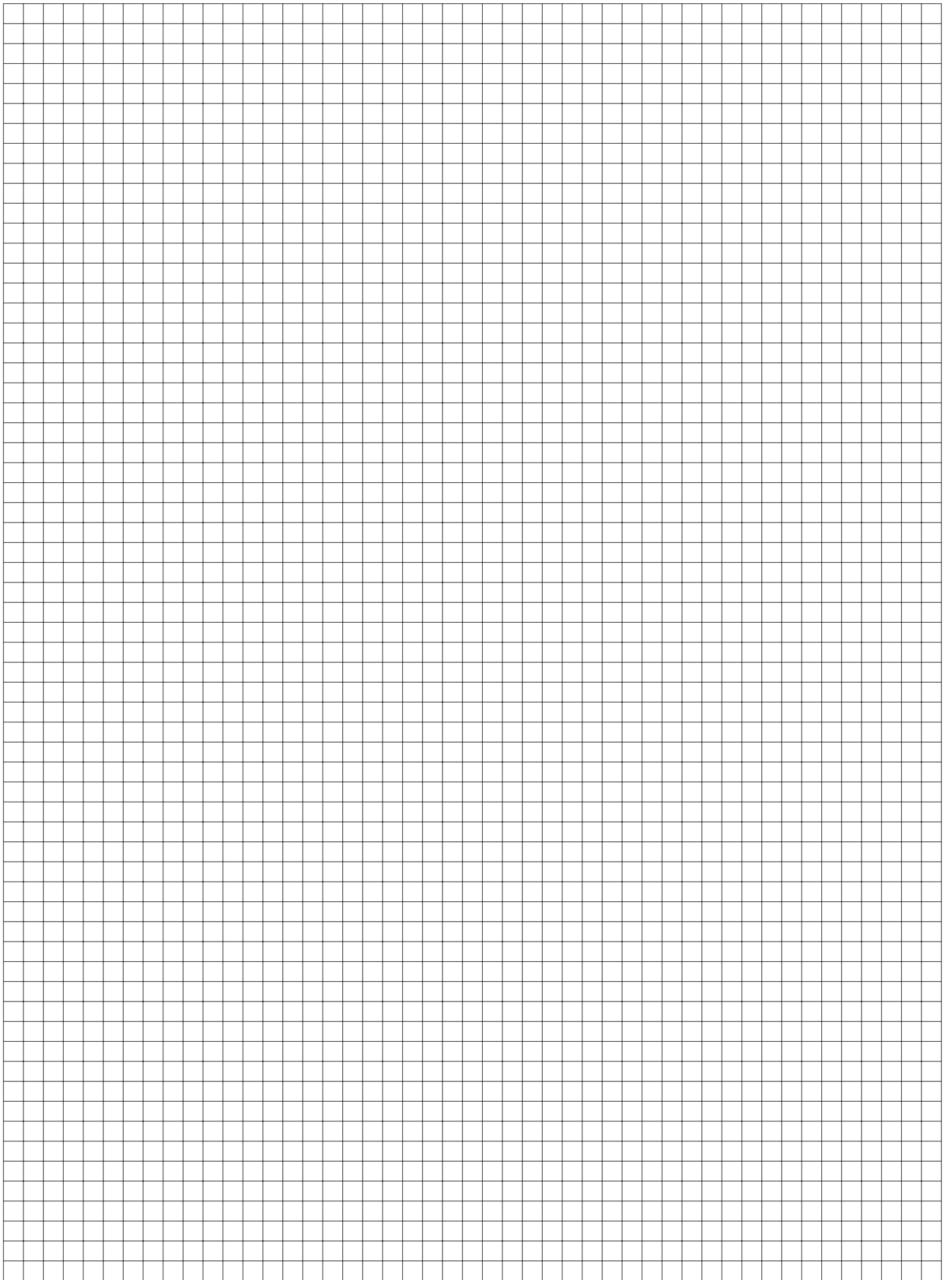

Geometry

DIRECTIONS

Read each question carefully. For a multiple-choice question, determine the best answer to the question from the four answer choices provided. For a griddable question, determine the best answer to the question. Then fill in the answer on your answer document.

- 1 \overline{CD} has an endpoint at $(2, -1)$ and a midpoint at $(8, 3)$. Which measure is closest to the length of \overline{CD} ?
- A** 20.4 units
B 8.9 units
C 14.4 units
D 11.7 units
-

- 2 Isosceles trapezoid $JKLM$ is shown below.

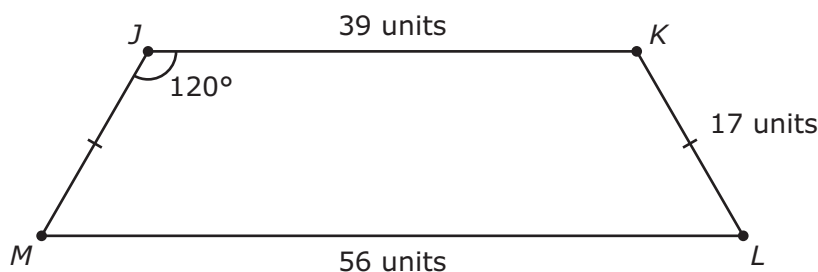

If the dimensions of trapezoid $JKLM$ are multiplied by a scale factor of f to create trapezoid $J'K'L'M'$, which statement is true?

- F** Trapezoid $J'K'L'M'$ contains two base angles measuring 30° each.
G The longer base of trapezoid $J'K'L'M'$ is $56f$ units.
H The bases of trapezoid $J'K'L'M'$ have lengths of 22 units and 39 units.
J Trapezoid $J'K'L'M'$ contains two base angles measuring $(120f)^\circ$ each.

- 3 Which pair of triangles has enough given information to prove that the triangles are congruent?

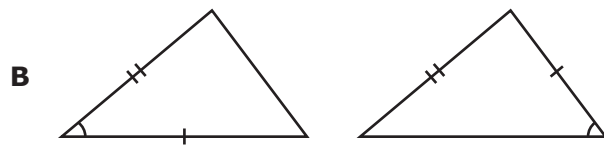
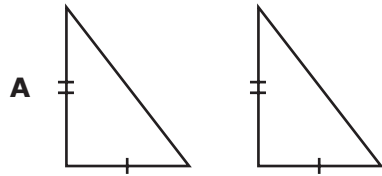

- D None of these

-
- 4 In the diagram below, the angle of depression from P to Q is 45° .

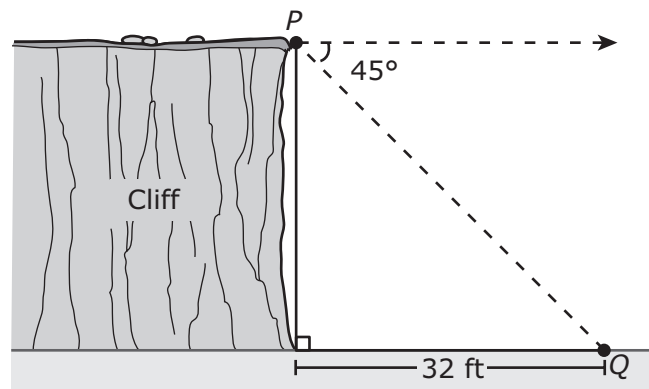

Not drawn to scale

Which of the following is closest to the distance between P and Q ?

- F 45.3 ft
G 22.6 ft
H 55.4 ft
J 18.5 ft

- 5 The rectangular pyramid shown below was intersected by a plane parallel to base $ABCD$ to form quadrilateral $A'B'C'D'$.

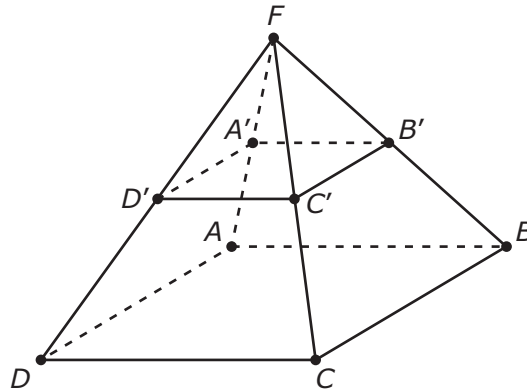

Based on this information, which statement cannot be proved true?

- | | |
|--|--|
| A $ABCD \sim A'B'C'D'$ | C $\angle AA'D' \cong \angle BB'A'$ |
| B $\frac{AF}{A'F} = \frac{BF}{B'F}$ | D $\angle BCD \cong \angle B'C'D'$ |

- 6 Five spheres are being painted for a display at a store. If the diameter of each sphere is 7 centimeters, which value is closest to the total surface area that will be painted?
- F** 770 cm^2
- G** 154 cm^2
- H** 192 cm^2
- J** 440 cm^2

- 7 On the map below, Main Street, 10th Street, and Highway 1 intersect to form a right triangle.

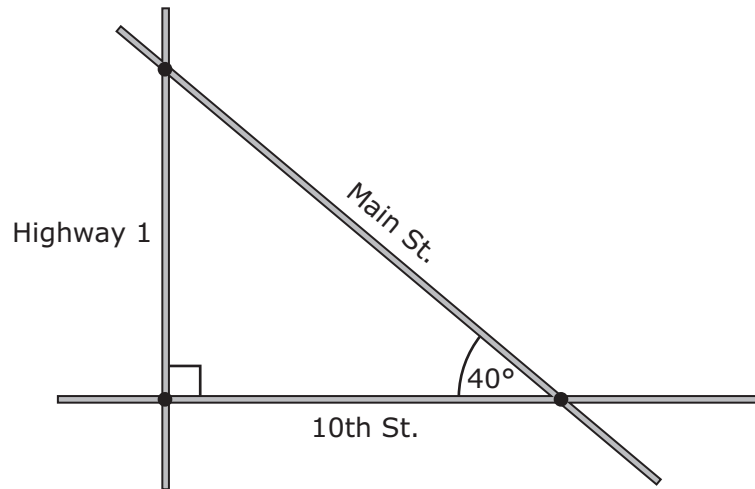

The distance between 10th Street and Main Street along Highway 1 is 5.6 mi. Which measure is closest to the length of Main Street from Highway 1 to 10th Street?

- A** 8.7 mi **C** 4.7 mi
B 3.6 mi **D** 7.3 mi

-
- 8 For triangles ABC and DEF , $\angle A \cong \angle D$ and $\angle B \cong \angle E$. Based on this information, which statement is a reasonable conclusion?

- F** $\angle C \cong \angle D$ because they are corresponding angles of congruent triangles.
G $\overline{CA} \cong \overline{FD}$ because they are corresponding parts of congruent triangles.
H $\angle C \cong \angle F$ because they are corresponding angles of similar triangles.
J $\overline{AB} \cong \overline{DE}$ because they are corresponding parts of similar triangles.

- 9 \overleftrightarrow{ZX} and \overleftrightarrow{WY} are secants of circle V , as shown below.

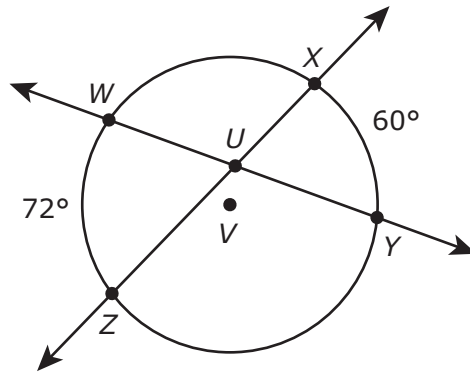

Based on this information, which of the following can be proved true?

- A** $m\angle ZUY = m\angle ZVY$
- B** $m\angle XUY = \frac{1}{2}(m\widehat{WZ} + m\widehat{XY})$
- C** $m\widehat{WX} = 180^\circ - m\widehat{WZ}$
- D** $m\angle WUX = \frac{1}{2}(m\widehat{ZY} - m\widehat{WX})$

- 10 \overline{PQ} is shown on the coordinate grid below. The coordinates of P and Q are integers.

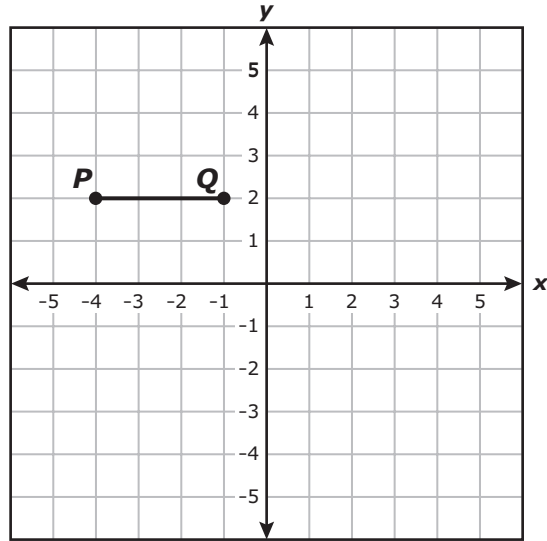

Point (x, y) lies on the perpendicular bisector of \overline{PQ} . What is the value of x ?

Record your answer and fill in the bubbles on your answer document.

-
- 11 A conditional statement is given below.

If two interior angles of a triangle are acute,
then the third interior angle must be obtuse.

Which of the following best describes this statement?

- A This statement is true because all obtuse triangles have two acute interior angles.
- B This statement is false because the third interior angle must also be acute.
- C This statement is true because a triangle can have at most one interior obtuse angle.
- D This statement is false because the third interior angle can be acute, right, or obtuse.

12 The side length of a smaller square is one-third the side length of a larger square. Which of the following statements describes the area of the smaller square?

F The area of the smaller square is $\frac{1}{27}$ the area of the larger square.

G The area of the smaller square is $\frac{1}{6}$ the area of the larger square.

H The area of the smaller square is $\frac{1}{9}$ the area of the larger square.

J The area of the smaller square is $\frac{1}{3}$ the area of the larger square.

13 A pattern of dots is shown in the four figures below.



Figure 1



Figure 2



Figure 3



Figure 4

If the pattern continues, which expression can be used to find the total number of dots in Figure n ?

A $3n - 5$

B $2n + 2$

C $2n + 3$

D $3n - 1$

- 14 The equation of a line containing one leg of a right triangle is $y = -4x$. Which of the following equations could represent the line containing the other leg of this triangle?

F $y = -\frac{1}{4}x$

H $y = 4x$

G $y = \frac{1}{4}x + 2$

J $y = -4x + 2$

-
- 15 Two regular hexagons with center C and apothems a and b are shown in the figure below. Each vertex of the smaller hexagon is a midpoint on a side of the larger hexagon.

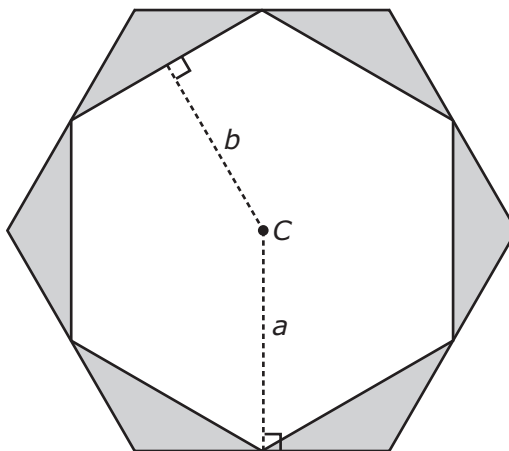

If $a = 12\sqrt{3}$ cm and $b = 18$ cm, what is the total area of the shaded regions?

- A $648\sqrt{3}$ cm²
- B $36\sqrt{3}$ cm²
- C $216\sqrt{3}$ cm²
- D $1,512\sqrt{3}$ cm²

- 16 The two conditional statements below are true.

If $\angle 3$ and $\angle 4$ form a linear pair, then they are supplementary.
If $\angle 3$ and $\angle 4$ are supplementary, then $m\angle 3 + m\angle 4 = 180^\circ$.

Based on these conditional statements, which statement must also be true?

- F** If $\angle 3$ and $\angle 4$ form a linear pair, then $m\angle 3 + m\angle 4 = 180^\circ$.
- G** If $\angle 3$ and $\angle 4$ form a linear pair, then $m\angle 3 = 90^\circ$, and $m\angle 4 = 90^\circ$.
- H** If $m\angle 3 + m\angle 4 = 180^\circ$, then $\angle 3$ and $\angle 4$ form a linear pair.
- J** If $\angle 3$ and $\angle 4$ are supplementary, then $\angle 3$ and $\angle 4$ form a linear pair.

-
- 17 Rectangle $STUW$ is shown below.

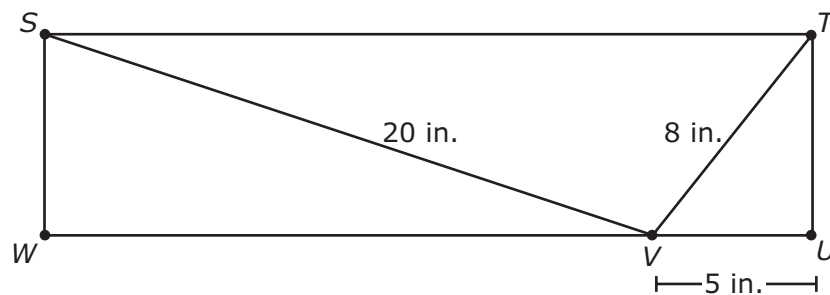

What is ST ?

- A** 33 in.
- B** 24 in.
- C** $\sqrt{464}$ in.
- D** $\sqrt{361}$ in.

18 A statement is given below.

The number of square units in the area of a square is greater than or equal to the number of units in the perimeter of the square.

Which side length of a square provides a counterexample to the given statement?

- F 6 units
- G 4 units
- H 10 units
- J 2 units

19 The table below contains a pattern formed by the number of sides and the measure in degrees of each exterior angle of several regular convex polygons.

Exterior Angle Measures of Regular Polygons

Number of Sides	3	4	5	6	10	15	20	45	90
Exterior Angle Measure (degrees)	120	90	72	60	36	24	18	8	4

If the pattern in the table continues, which statement is true?

- A As the number of sides in the polygon increases by 1, the measure of each exterior angle decreases by 25%.
- B The product of the number of sides in the polygon and the measure of each exterior angle is a constant.
- C The measure of each exterior angle is a multiple of 6 degrees.
- D If the number of sides in the polygon is even, the measure of each exterior angle is a multiple of 3 degrees.

- 20** The volume of a rectangular prism is 960 cubic inches. If the dimensions of the base are doubled and the height remains the same to create a new prism, what will be the volume of the new rectangular prism in cubic inches?

Record your answer and fill in the bubbles on your answer document.

-
- 21** The hand on the circular clock in the figure below measures 10 cm.

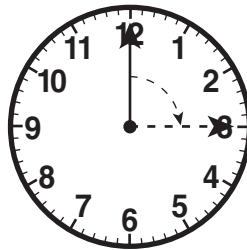

Which of the following is closest to the distance that the tip of the hand travels as it moves from the 12 to the 3?

- A** 79 cm
 - B** 21 cm
 - C** 63 cm
 - D** 16 cm
-
- 22** A plane intersects a cylinder. Which of the following cannot be formed by this intersection?
- F** Triangle
 - G** Line
 - H** Rectangle
 - J** Circle

23 Which expression can be used to find the length of \overline{QR} in centimeters?

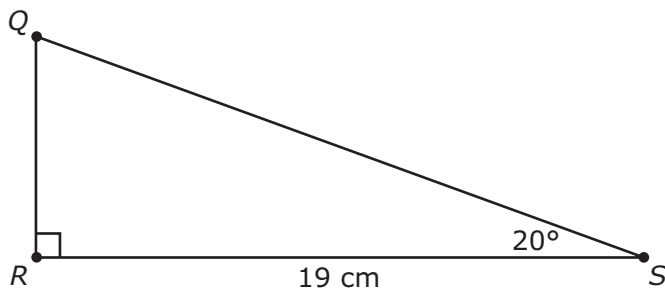

- A $19(\cos 20^\circ)$
- B $19(\tan 20^\circ)$
- C $19(\sin 70^\circ)$
- D $19(\tan 70^\circ)$

24 In circle E below, $\angle AEB \cong \angle CED$.

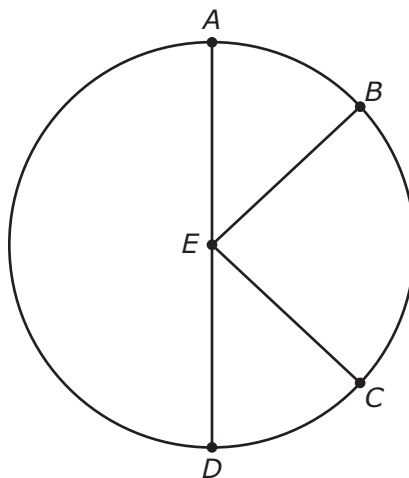

Based on this information, which statement must be true?

- F $\overline{AB} \cong \overline{CD}$
- G $\overline{EB} \perp \overline{EC}$
- H $m\angle AED = 4(m\angle DEC)$
- J $m\angle AEB + m\angle DEC = m\angle BEC$

25 The graph of line g is shown below.

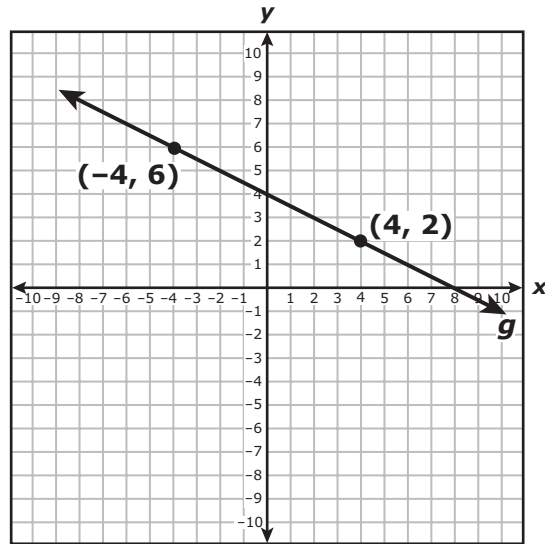

Which equation describes a line parallel to line g that has a y -intercept at $(0, -1)$?

A $y = 2x - 1$

C $y = -\frac{1}{2}x - 1$

B $y = \frac{1}{2}x - 1$

D $y = -2x - 1$

- 26** Three gears in a machine are positioned relative to each other to form an isosceles right triangle, as shown below.

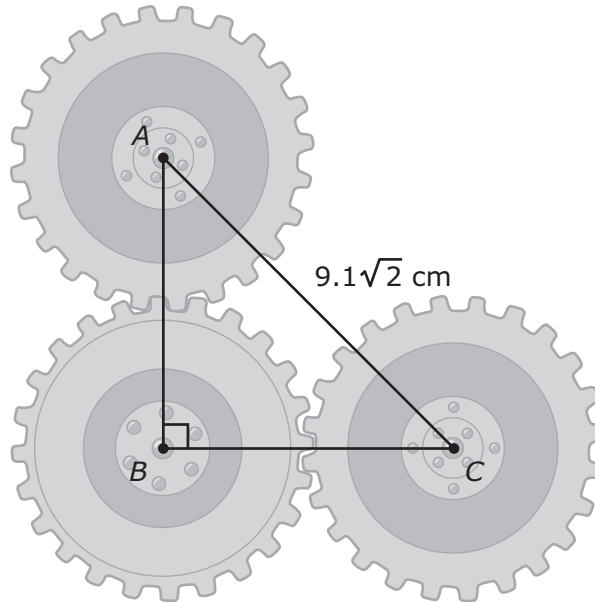

What is the distance in centimeters between the centers of the gears located at B and C ?

Record your answer and fill in the bubbles on your answer document.

-
- 27** The following conditional statement is true.

If a quadrilateral is a square, then it has four congruent sides.

Which statement must also be true?

- A** If a quadrilateral has four congruent sides, then it is a square.
- B** If a quadrilateral does not have four congruent sides, then it is not a square.
- C** If a quadrilateral is not a square, then it does not have four congruent sides.
- D** If a quadrilateral does not have four congruent sides, then it is a square.

28 A conical paper cup is shown in the diagram below.

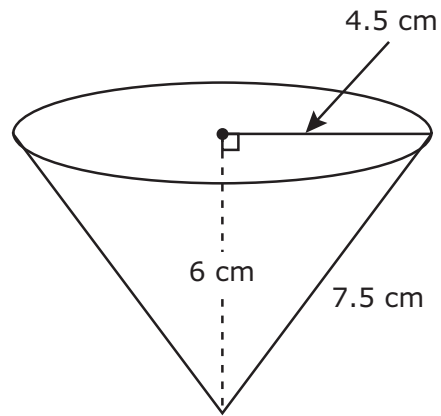

Which value is closest to the maximum volume of water this cup can hold?

- F** 159 cm^3
- G** 32 cm^3
- H** 127 cm^3
- J** 40 cm^3

29 The slope of a line passing through $H(-2, 5)$ is $-\frac{3}{4}$. Which ordered pair represents a point on this line?

- A** $(6, -1)$
- B** $(2, 8)$
- C** $(-5, 1)$
- D** $(1, 1)$

30 Which statement about a triangular prism is true?

- F** A triangular prism has 4 faces, 6 edges, and 4 vertices.
- G** A triangular prism has 3 faces, 6 edges, and 3 vertices.
- H** A triangular prism has 5 faces, 9 edges, and 6 vertices.
- J** A triangular prism has 6 faces, 11 edges, and 8 vertices.

31 In $\triangle QRS$, \overline{RT} is an altitude.

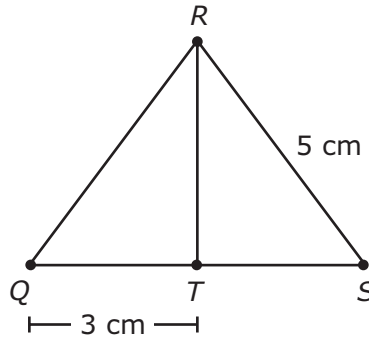

Which additional condition would not be sufficient to prove that $QR = SR$?

- A T is the midpoint of \overline{QS} .
- B \overline{RT} bisects $\angle QRS$.
- C $TS = 2$ cm
- D $RT = 4$ cm

32 Lines r , t , n , and v intersect as shown to form isosceles trapezoid $ABCD$.

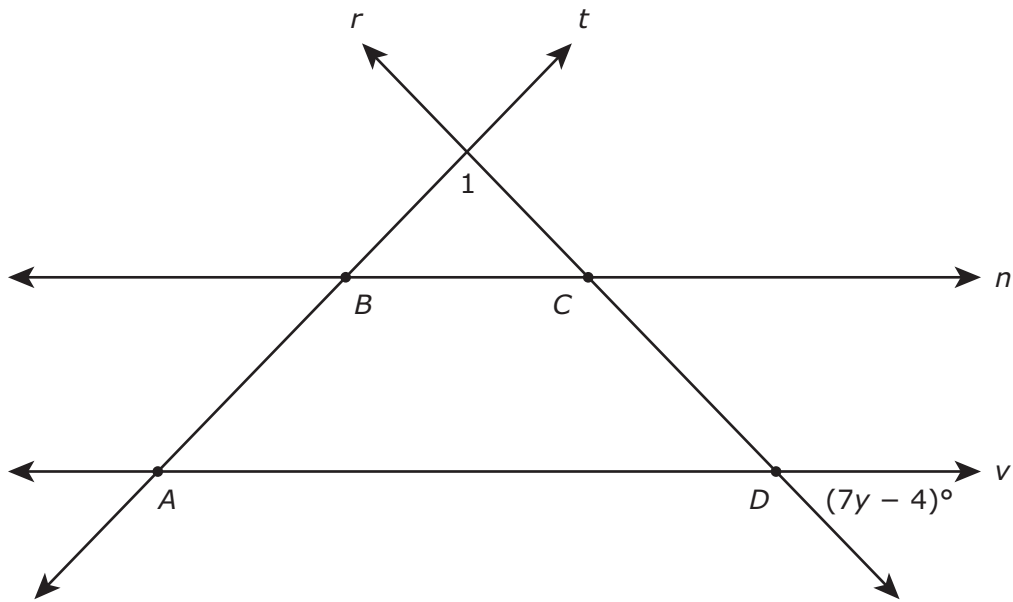

Which expression represents the measure of $\angle 1$ in degrees?

F $180 \div (7y - 4)$

H $(7y - 4)$

G $180 - 2(7y - 4)$

J $180 - (7y - 4)$

33 A banner is composed of two congruent triangles and a rectangle, as shown below.

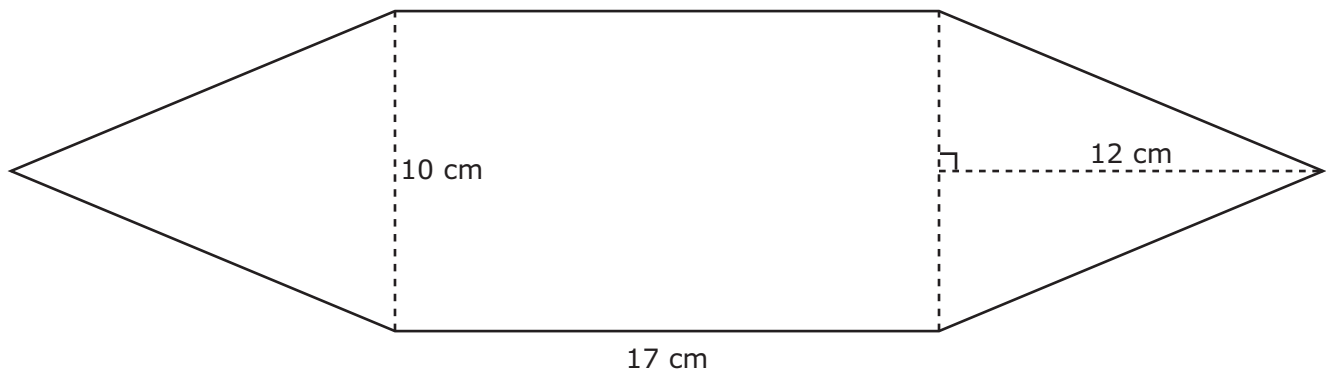

What is the total area of the banner in square centimeters?

Record your answer and fill in the bubbles on your answer document.

- 34** The front, side, and top views of a three-dimensional figure made of identical cubes are shown below.

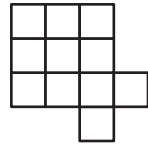

Top view

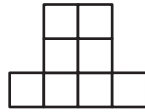

Front view

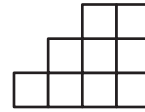

Side view

Which diagram best represents this three-dimensional figure?

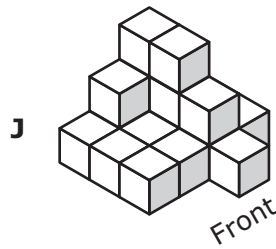
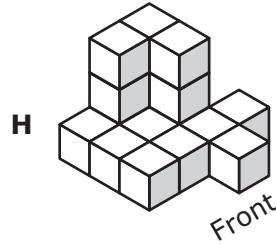
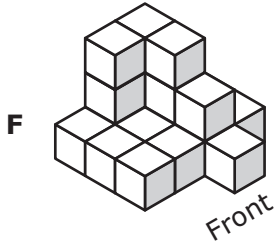

35 The first four stages of a pattern of arcs from congruent circles are shown below.

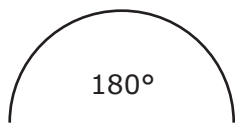

Stage 1

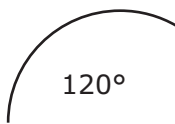

Stage 2

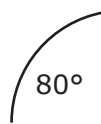

Stage 3

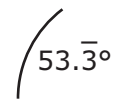

Stage 4

If this pattern continues, which expression can be used to find the degree measure of the arc in Stage n ?

A $20(10 - n^2)$

B $180\left(\frac{1}{3}\right)^{(n-1)}$

C $60(4 - n)$

D $270\left(\frac{2}{3}\right)^n$

36 In the figure below, $k \parallel t$ and $k \perp q$.

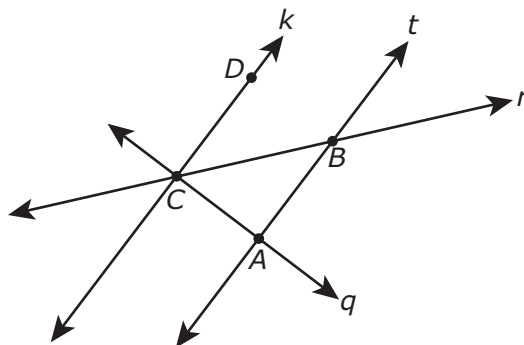

Based on this information, which statement can be proved true?

F $\angle ACB \cong \angle ABC$

G $\triangle CAB$ is an acute triangle.

H $\angle DCB \cong \angle BCA$

J $\triangle CAB$ is a right triangle.

- 37** The main entrance to the Louvre art museum is shaped like a pyramid. The pyramid is 71 feet tall and has a slant height of approximately 91 feet. Each side of the square base measures 115 feet.

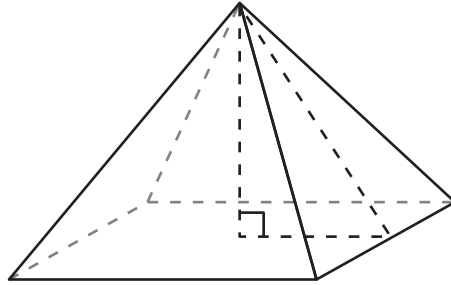

Which of the following is closest to the lateral surface area of the pyramid?

- A** 20,930 ft²
- B** 16,330 ft²
- C** 10,465 ft²
- D** 34,155 ft²

- 38** A company is designing a flotation device made of foam. The shape of the design is modeled below.

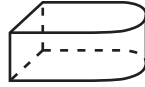

Which net can be folded to form the shape of the flotation device?

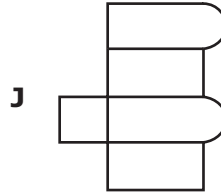
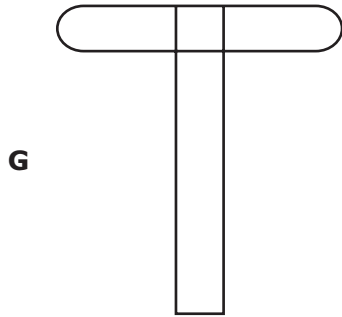
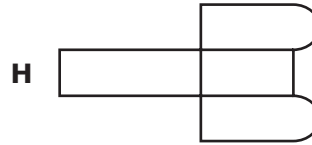
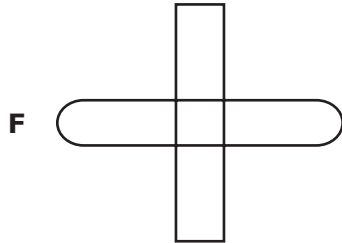

39 The diagram below shows the arcs and segments used to construct $\triangle ABC$, given line k .

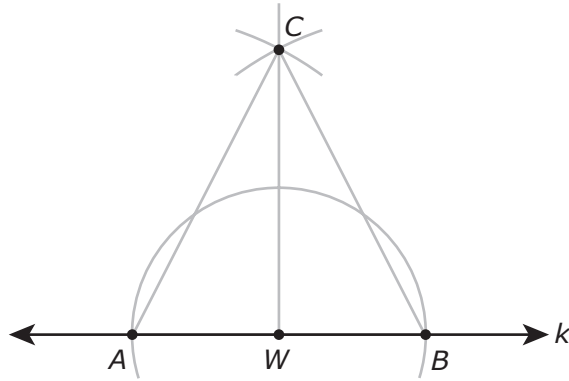

Based on this construction, which statement is not true?

- A $\angle AWC$ is complementary to $\angle CWB$.
- B $\triangle CWB$ is a right triangle.
- C $\triangle ACB$ is isosceles.
- D $m\angle CAB = m\angle CBA$

40 Parallelogram $ABCD$ was transformed to form parallelogram $A'B'C'D'$.

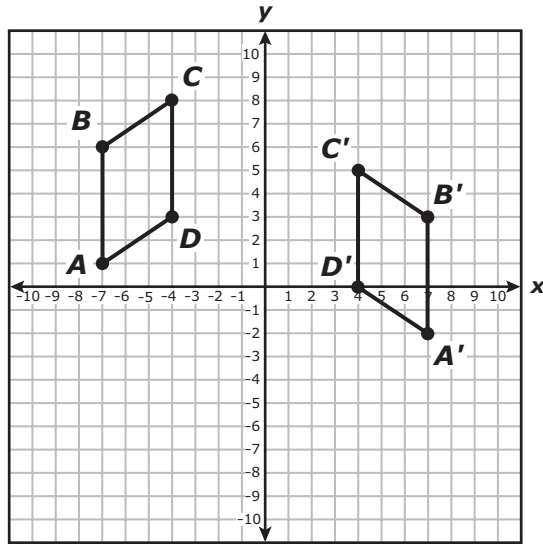

Which rule describes the transformation that was used to form parallelogram $A'B'C'D'$?

- F $(x, -y)$
- G $(-x, y)$
- H $(x + 6, -y)$
- J $(-x, y - 3)$

- 41** Within a square section of land, a landscaper will build a path, as represented by the shaded section in the diagram below.

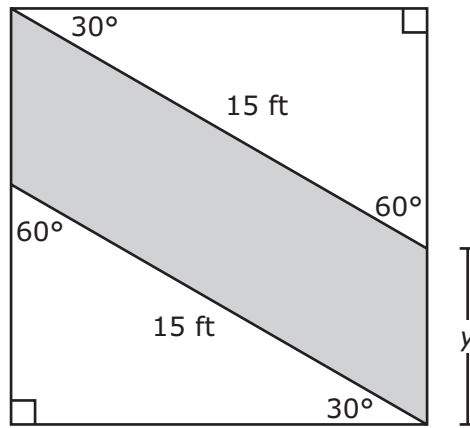

Which measure is closest to the value of y ?

- A** 5.5 ft
 - B** 3.1 ft
 - C** 4.3 ft
 - D** 7.5 ft
-
- 42** The top of a bench has a length of 5 ft and a width of 2 ft. A second bench is similar to the first bench. The top of the second bench is 3 ft wide. What is the length of the top of the second bench?
- F** 6 ft
 - G** 7 ft
 - H** 4.5 ft
 - J** 7.5 ft

- 43 $\triangle ABC$ and $\triangle PQR$ are shown in the diagram below.

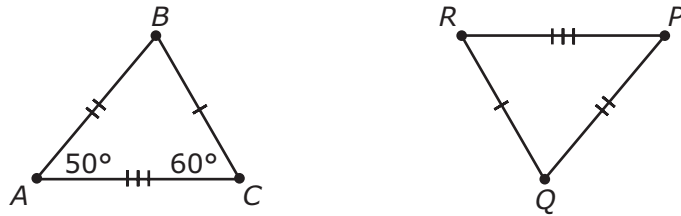

Based on the information provided in the diagram, what is $m\angle P$ in degrees?

Record your answer and fill in the bubbles on your answer document.

-
- 44 A civil engineer is drawing a plan for the location and length of a new underground sewer pipe on a coordinate grid. The pipe on the plan will run from point $N(a, -2)$ to point $P(1, b)$ on the coordinate grid. Which expression represents the shortest distance between N and P in units?

- F** $(a + 2)^2 + (1 - b)^2$
- G** $(1 - a)^2 + (b + 2)^2$
- H** $\sqrt{(a + 2)^2 + (1 - b)^2}$
- J** $\sqrt{(1 - a)^2 + (b + 2)^2}$

- 45 In the spinner modeled below, Sector 1 has twice the area of Sector 3.

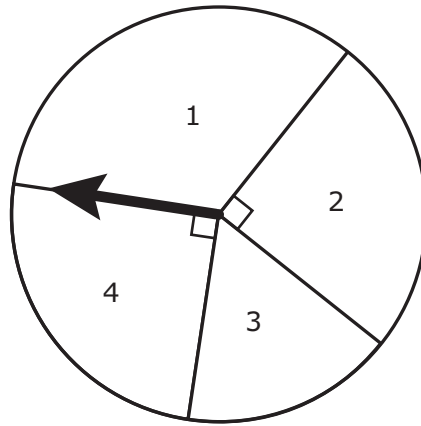

If the arrow is spun once, what is the probability that the arrow will land in Sector 1?

- A $\frac{1}{3}$ C $\frac{1}{6}$
B $\frac{1}{4}$ D $\frac{2}{3}$

-
- 46 A triangle is enlarged by multiplying each of its dimensions by 4. Based on this information, which of the following statements is true?
- F The perimeter of the new triangle is 12 times the perimeter of the original triangle.
G The perimeter of the new triangle is 16 times the perimeter of the original triangle.
H The perimeter of the new triangle is 18 times the perimeter of the original triangle.
J The perimeter of the new triangle is 4 times the perimeter of the original triangle.

- 47 The slopes of the sides of quadrilateral $ABCD$ are shown in the table below.

Side	Slope
\overline{AB}	$\frac{2}{5}$
\overline{BC}	$-\frac{2}{5}$
\overline{CD}	$\frac{2}{5}$
\overline{AD}	$-\frac{5}{2}$

Which statement describes the relationships between the sides of the quadrilateral?

- A \overline{AD} is parallel to \overline{BC} , but \overline{AB} is not parallel to \overline{CD} .
- B \overline{AB} is parallel to \overline{CD} , but \overline{AD} is not parallel to \overline{BC} .
- C \overline{AB} is parallel to \overline{CD} , and \overline{AD} is parallel to \overline{BC} .
- D \overline{AD} is not parallel to \overline{BC} , and \overline{AB} is not parallel to \overline{CD} .
-
- 48 Two motorcycles start at the same point. One motorcycle travels 15 km due north and stops. The second motorcycle travels 32 km due west and stops. Which value is closest to the distance between the motorcycles when they stop?
- F 28.3 km
- G 47.0 km
- H 35.3 km
- J 21.9 km

- 49** A town wants to fence in a rectangular section of a park. The table shows five possible plans for the dimensions of this fenced section. The changes in the width and the length of these plans follow a pattern.

Plan	Width (feet)	Length (feet)	Area (square feet)
1	16	34	544
2	18	32	576
3	20	30	600
4	22	28	616
5	24	26	624

If six additional plans are added to the table and follow the same pattern, which conclusion is not correct?

- A** The area of one of the additional plans exceeds 624 square feet.
- B** The area of one of the additional plans is less than 544 square feet.
- C** The area in Plan 6 is the same as the area in Plan 5.
- D** The area in Plan 7 is less than the area in Plan 6.

- 50 Points A , B , C , and D are the vertices of a square. Points E and F are the centers of two congruent semicircles that are tangent to each other at point G .

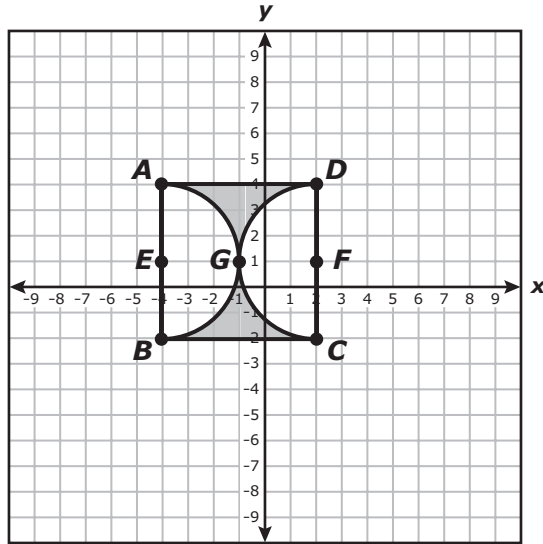

Which value is closest to the area of the shaded regions?

- F 7.7 units²
- G 4.3 units²
- H 17.2 units²
- J 64.3 units²

- 51** The diagram below represents one layout of a hexagonal swimming pool that contains a drain at point D in the center of a rectangular yard.

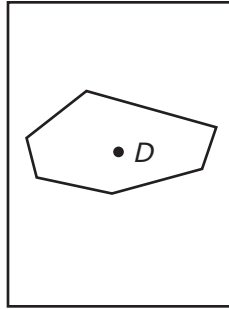

Other layouts are also being considered. Which layout is the result of a 90° counterclockwise rotation of the original layout using D as the center of rotation?

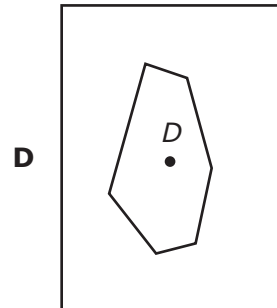
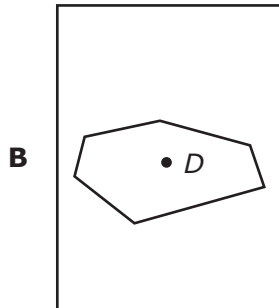
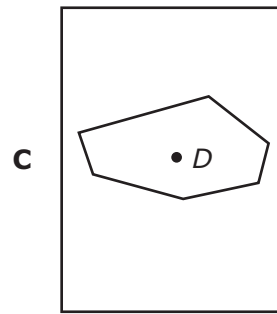
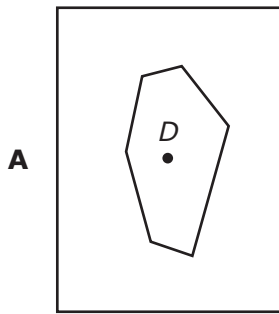

52 In $\triangle DAC$ shown below, $\overline{EB} \parallel \overline{DC}$.

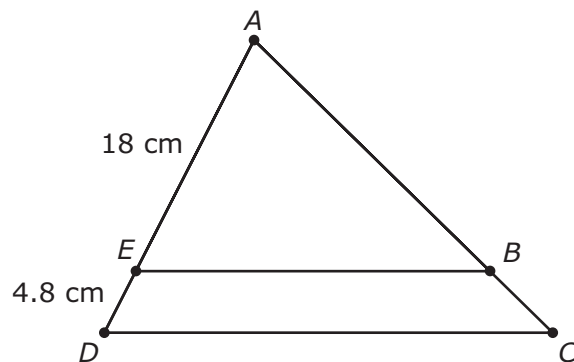

If $AC = 28.5$ cm, what is the length of \overline{AB} ?

- F** 22.5 cm
- G** 14.4 cm
- H** 36.1 cm
- J** 23.7 cm



**STAAR
Geometry
May 2013**

