

Geometry

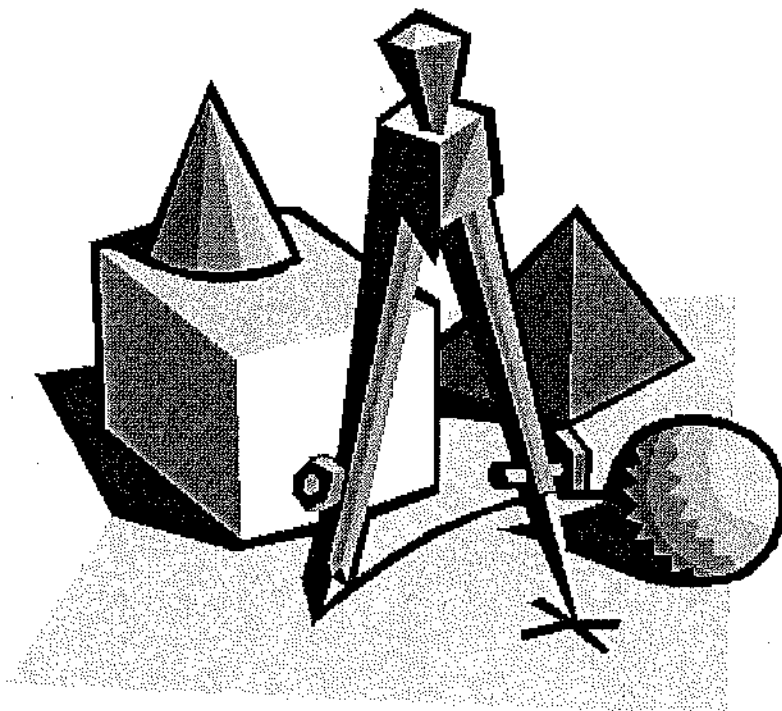

MCAS Practice Problems

Name _____ PD _____

1 Exactly three diagonals can be drawn from **each** vertex of a given polygon. What is the total number of sides of the polygon?

Mark your answer here: 1. (A)(B)(C)(D)

- A. 3
- B. 4
- C. 5
- D. 6

2 The shapes of some common traffic signs are shown below. Which of the following shapes does **not** have rotational symmetry?

Mark your answer here: 2. (A)(B)(C)(D)

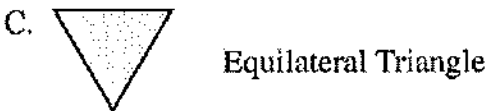
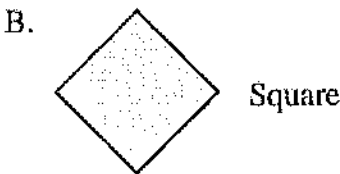
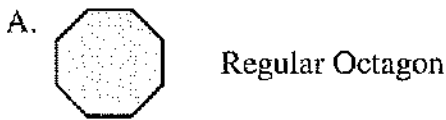

- 3** A quadrilateral with sides measuring 5 inches, 7 inches, 12 inches, and 9 inches is drawn on a chalkboard. Which of the following could be the quadrilateral?
- A. a trapezoid
 - B. a rectangle
 - C. a rhombus
 - D. a kite

Mark your answer here: 3. (A)(B)(C)(D)

- 4** Which of the following **always** has line symmetry?
- A. a triangle
 - B. a rectangle
 - C. a trapezoid
 - D. a parallelogram

Mark your answer here: 4. (A)(B)(C)(D)



- 1 In the diagram below, line l is parallel to line m , and line k intersects both lines.

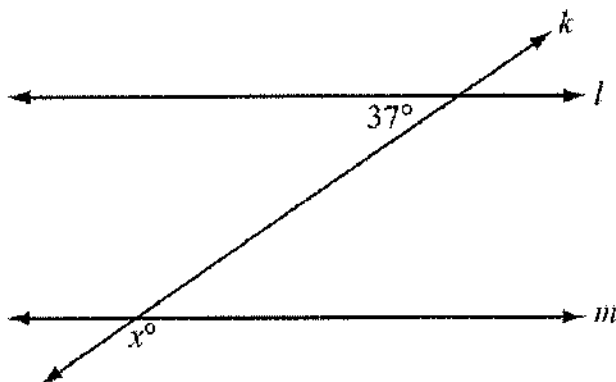

Based on the angle measure in the diagram, what is the value of x ?

- A. 37
- B. 53
- C. 127
- D. 143

Mark your answer here: 1. (A)(B)(C)(D)

- 2 In the diagram below, $\overleftrightarrow{JL} \parallel \overleftrightarrow{KM}$.

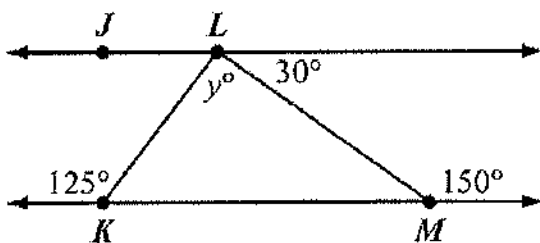

Based on the angle measures in the diagram, what is the value of y ?

- A. 75
- B. 90
- C. 95
- D. 120

Mark your answer here: 2. (A)(B)(C)(D)



- 3 In circle D , \overline{BC} is a diameter, \overline{DA} is a radius, and $m\widehat{AB} = 60^\circ$.

Mark your answer here: 3. (A)(B)(C)(D)

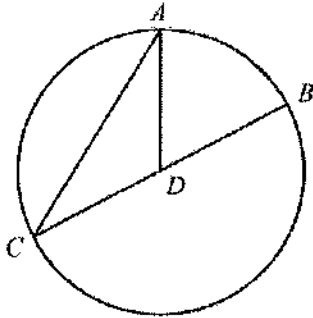

What is $m\angle CAD$?

- A. 30°
- B. 50°
- C. 60°
- D. 70°



- 4 Parallel lines r and s are cut by transversal t , as shown in the diagram below.

Mark your answer here: 4. (A)(B)(C)(D)

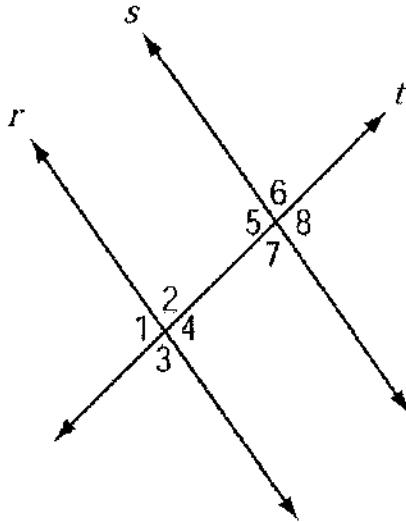

Which of the following **must** be true?

- A. $m\angle 1 + m\angle 5 = 180^\circ$
- B. $m\angle 2 + m\angle 8 = 180^\circ$
- C. $m\angle 1 = m\angle 7$
- D. $m\angle 3 = m\angle 8$



- 5 In the circle shown below, \overline{AD} , \overline{BE} , and \overline{CF} are diameters.

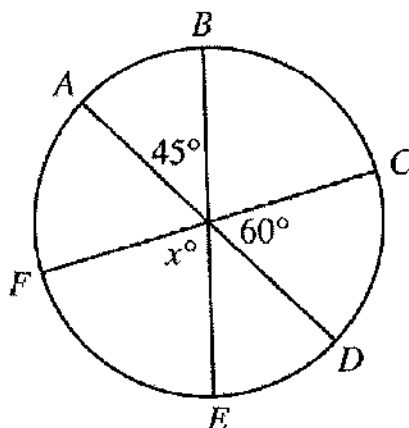

What is the value, in degrees, of x ?

Write your answer here:



1 In the diagram below, $\triangle MNP \sim \triangle RST$.

Mark your answer here: 1. (A)(B)(C)(D)

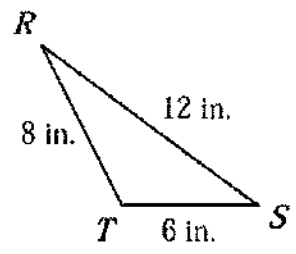
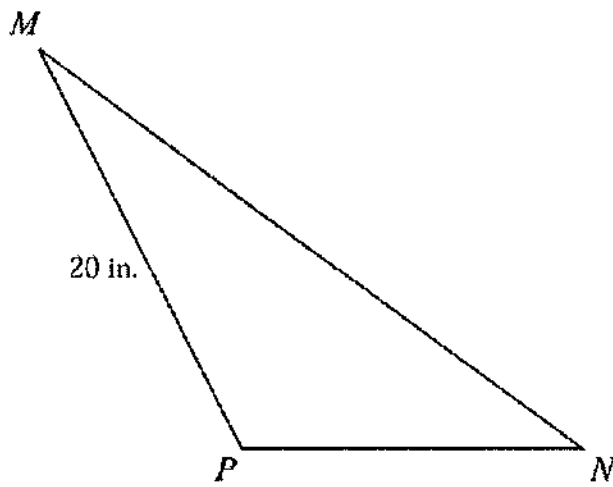

Based on the dimensions in the diagram, what is the length of \overline{MN} ?

- A. 15 in.
- B. 24 in.
- C. 30 in.
- D. 40 in.



Directions: For the problem below, use a separate piece of paper to write your answers. Your teacher will not count anything you write on this page.

2 The diagram below shows $\triangle RST$.

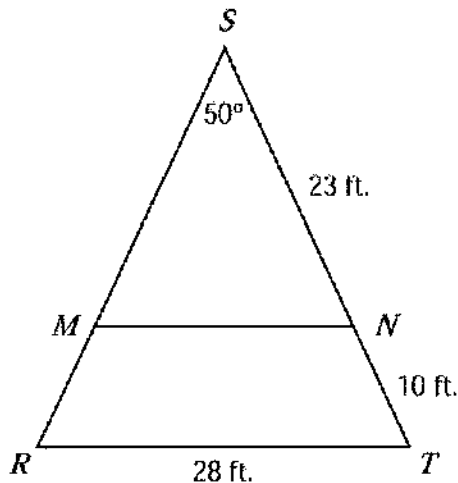

- $\triangle RST$ is an isosceles triangle with congruent sides \overline{RS} and \overline{ST} .
 - Point M lies on \overline{RS} , and point N lies on \overline{ST} .
 - \overline{MN} is parallel to \overline{RT} .
 - The length of \overline{SN} is 23 feet, and the length of \overline{NT} is 10 feet.
- a. What is the length of \overline{RS} ? Show or explain how you got your answer.
 - b. What is $m\angle T$? Show or explain how you got your answer.
 - c. What is $m\angle MNS$? Show or explain how you got your answer.
 - d. Explain why $\triangle MNS$ is similar to $\triangle RTS$.
 - e. What is the length of \overline{MN} ? Show or explain how you got your answer.



- 1 Triangle PQR in the diagram below represents Pam's trip across a river.

Mark your answer here: 1. (A)(B)(C)(D)

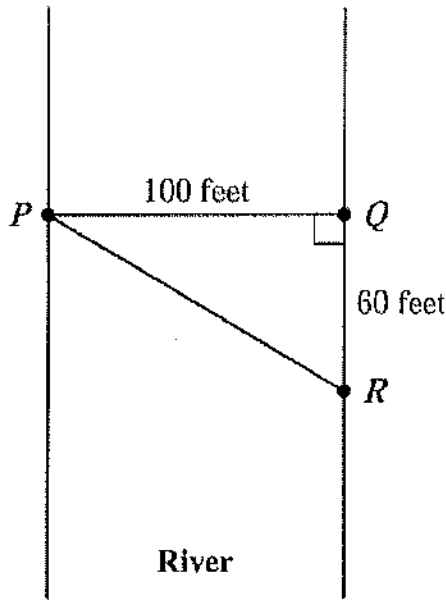

In the diagram, \overline{PQ} represents her planned trip across the river, and \overline{PR} represents her actual trip across the river.

Based on the dimensions in the diagram, which of the following is closest to the length of \overline{PR} ?

- A. 104 feet
- B. 117 feet
- C. 120 feet
- D. 160 feet



- 2 The diagram below shows a triangle and some of its dimensions.

Mark your answer here: 2. (A)(B)(C)(D)

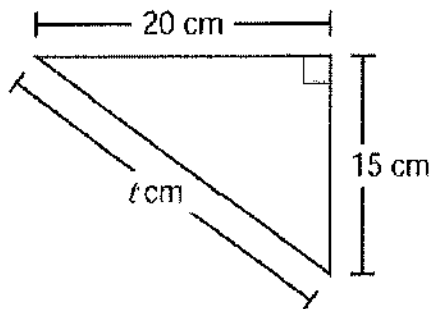

What is the value of l ?

- A. 25
- B. 30
- C. 35
- D. 40

- 3 A right triangle is shown below.

Mark your answer here: 3. (A)(B)(C)(D)

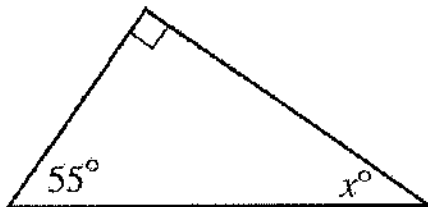

What is the value, in degrees, of x ?

- A. 25
- B. 35
- C. 45
- D. 55



- 4 In the diagram below, \overline{EH} intersects \overline{FJ} at point G .

Mark your answer here: 4. (A)(B)(C)(D)

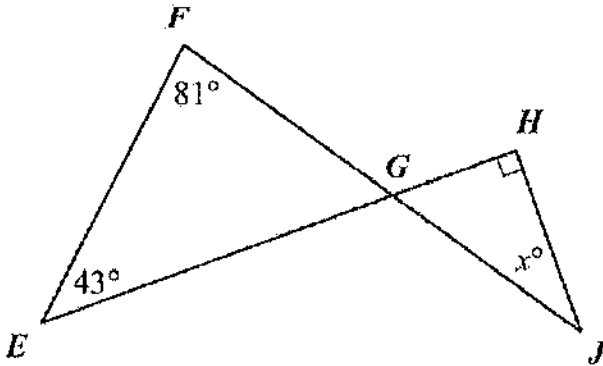

Based on the angle measures in the diagram, what is the value of x ?

- A. 34
- B. 38
- C. 43
- D. 56



- 1 In the diagram below, $\triangle RST$ is equilateral, and U is the midpoint of \overline{RT} .

Mark your answer here: 1. (A)(B)(C)(D)

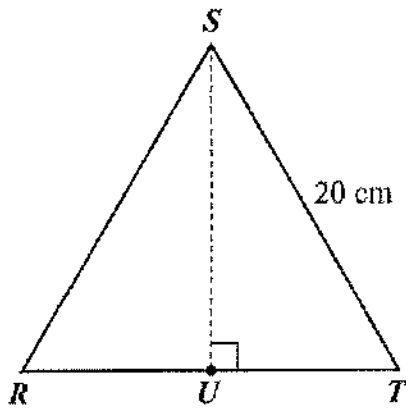

If the length of \overline{ST} is 20 centimeters, what is the length of \overline{SU} ?

- A. 10 cm
- B. $10\sqrt{3}$ cm
- C. 20 cm
- D. $20\sqrt{3}$ cm



- 2 Gail drew square $PQRS$ shown below.

Mark your answer here: 2. (A)(B)(C)(D)

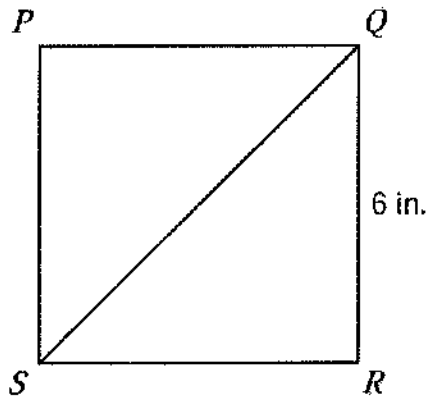

What is the length, in inches, of \overline{SQ} ?

- A. $6\sqrt{2}$
- B. 9
- C. $6\sqrt{3}$
- D. 12



- 3 For a movie scene, a stuntman will slide down a wire that is connected from the top of a building to the ground. The wire, the side of the building, and the ground can be represented as the sides of a right triangle, as shown in the figure below.

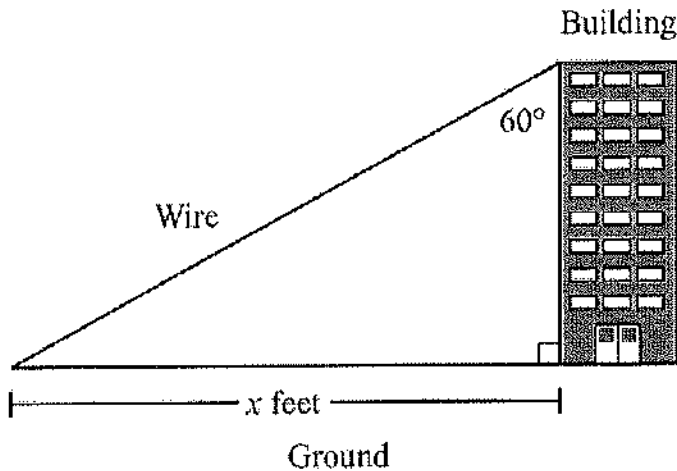

Mark your answer here: 3. (A)(B)(C)(D)

The height of the building where the wire is attached is 70 feet. Based on the angle measure in the figure, which of the following is closest to the value of x ?

- A. 40.4
- B. 70.0
- C. 121.2
- D. 140.0



Directions: For the problem below, use a separate piece of paper to write your answers. Your teacher will not count anything you write on this page.

- 4 Isosceles triangle ABC , with height BD , is shown in the diagram below.

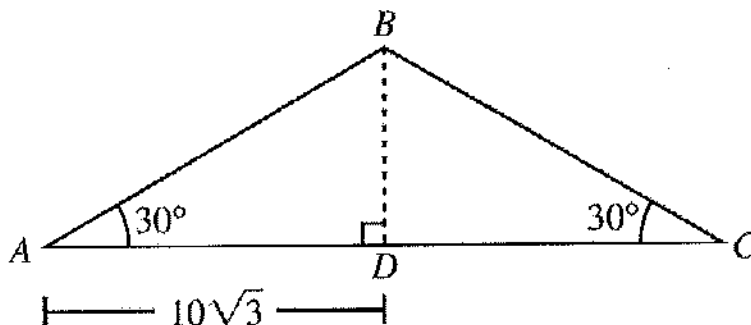

In the diagram, AD equals $10\sqrt{3}$ units.

- What is DC , in units? Show or explain how you got your answer.
- What is $m\angle ABD$, in degrees? Show or explain how you got your answer.
- What is BD , in units? Show or explain how you got your answer.
- What is AB , in units? Show or explain how you got your answer.



- 1 Line segment AB is plotted on the coordinate grid below.

Mark your answer here: 1. A B C D

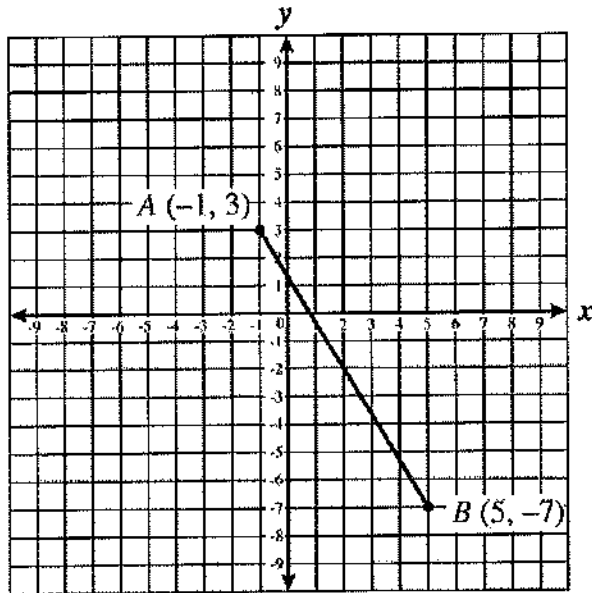

What is the midpoint of line segment AB ?

- A. $(3, -5)$
- B. $(2, -2)$
- C. $(-2, 2)$
- D. $(-5, 3)$



- 2 The coordinate grid below shows point $H(5, 2)$, point $K(7, 10)$, and \overline{HK} .

Mark your answer here: 2. (A)(B)(C)(D)

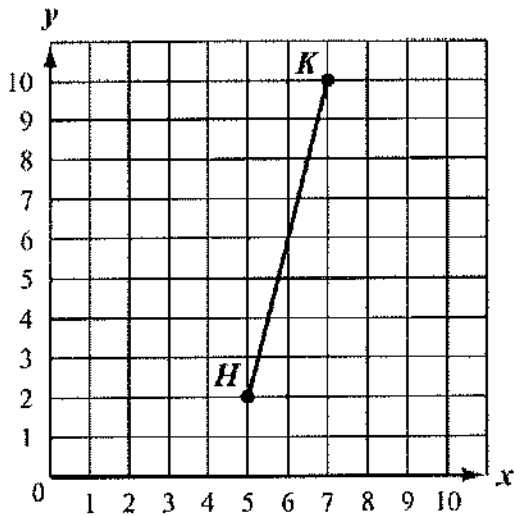

What is the slope of \overline{HK} ?

- A. -4
- B. $-\frac{1}{4}$
- C. $\frac{1}{4}$
- D. 4



- 3 On the coordinate grid below, \overline{ST} is shown.

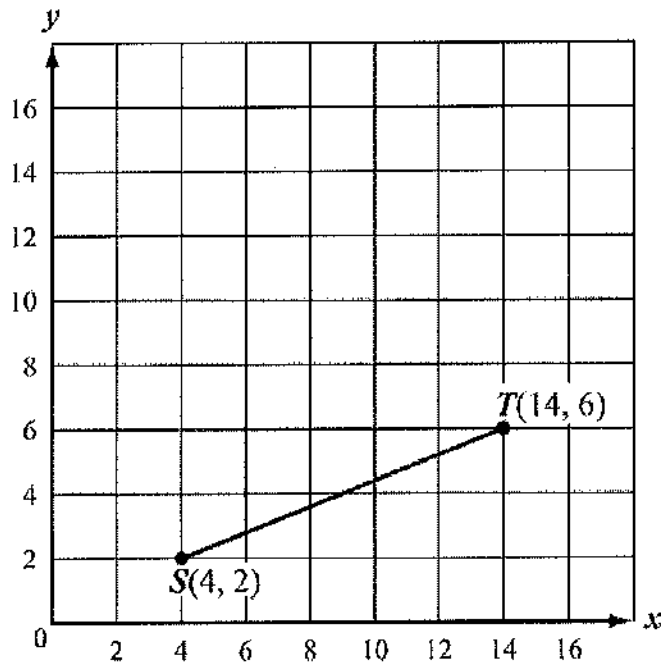

Write the ordered pair that represents the midpoint of \overline{ST} .

Write your answer here:



Directions: For the problem below, use a separate piece of paper to write your answers. Your teacher will not count anything you write on this page.

- 7** Gary makes signal flags for use in sailing. He drew rectangle $PQRS$ on a coordinate grid to represent a flag, with vertices $P(10,10)$, $Q(70,10)$, $R(70,40)$, and $S(10,40)$, as shown below.

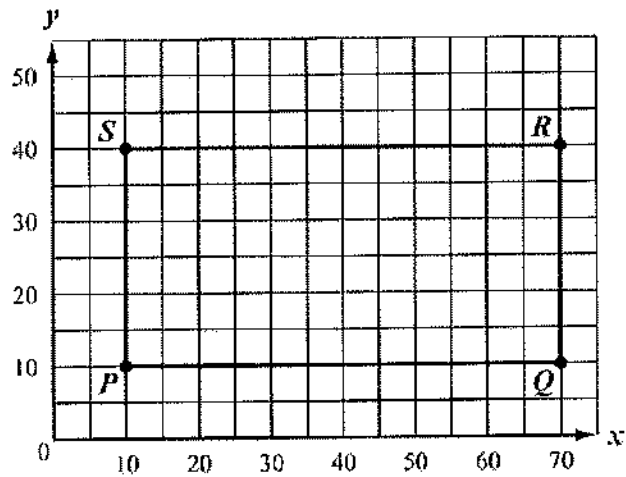

- a. What is the length, in units, of \overline{PQ} ? Show or explain how you got your answer.
- b. What is the length, in units, of \overline{SP} ? Show or explain how you got your answer.

Copy the x -axis, the y -axis, and rectangle $PQRS$ onto the grid in your Student Answer Booklet. Define the midpoint of each side of rectangle $PQRS$ as follows:

- W is the midpoint of \overline{PQ} .
 - X is the midpoint of \overline{QR} .
 - Y is the midpoint of \overline{RS} .
 - Z is the midpoint of \overline{SP} .
- c. On your coordinate grid, plot the midpoints W , X , Y , and Z .
 - Label each midpoint with its letter and coordinates.
 - Show or explain how you determined the coordinates of each midpoint.
 - Draw quadrilateral $WXYZ$.
 - d. On the flag, quadrilateral $WXYZ$ represents the boundary of a region that will be colored red. What is the perimeter, in units, of quadrilateral $WXYZ$? Show or explain how you got your answer.



- 1 The coordinates of the endpoints of \overline{ST} and its image $\overline{S'T'}$ are given below.

$$\begin{array}{ll} S(2, -4) & S'(-2, -4) \\ T(-1, 1) & T'(1, 1) \end{array}$$

Which of the following single transformations maps \overline{ST} to $\overline{S'T'}$?

- A. translation 4 units to the left
- B. rotation 180° clockwise about the origin
- C. reflection over the x -axis
- D. reflection over the y -axis

- 2 Point H is located at $(-3, 5)$ on a coordinate grid. Point H is then reflected over the y -axis.

What are the coordinates of the image of point H ?

- A. $(3, 5)$
- B. $(5, -3)$
- C. $(-3, -5)$
- D. $(-5, 3)$

Mark your answer here: 1. (A)(B)(C)(D)

Mark your answer here: 2. (A)(B)(C)(D)

- 3 Point $P(6, 7)$ and point $Q(6, 4)$ are plotted on the coordinate grid below.

Mark your answer here: 3. (A)(B)(C)(D)

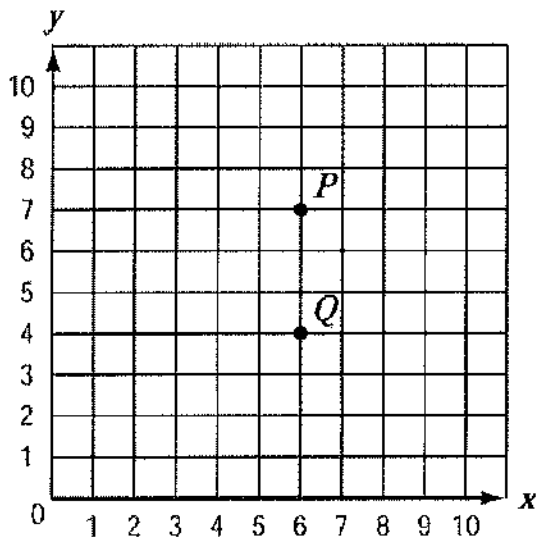

Point P is rotated 180° clockwise about point Q . What are the coordinates of the image of point P after this rotation?

- A. (3, 4)
- B. (6, 1)
- C. (6, 10)
- D. (9, 4)



Directions: For the problem below, use a separate piece of paper to write your answers. Your teacher will not count anything you write on this page.

- 4** Rectangle $QRST$ is shown on the coordinate grid below.

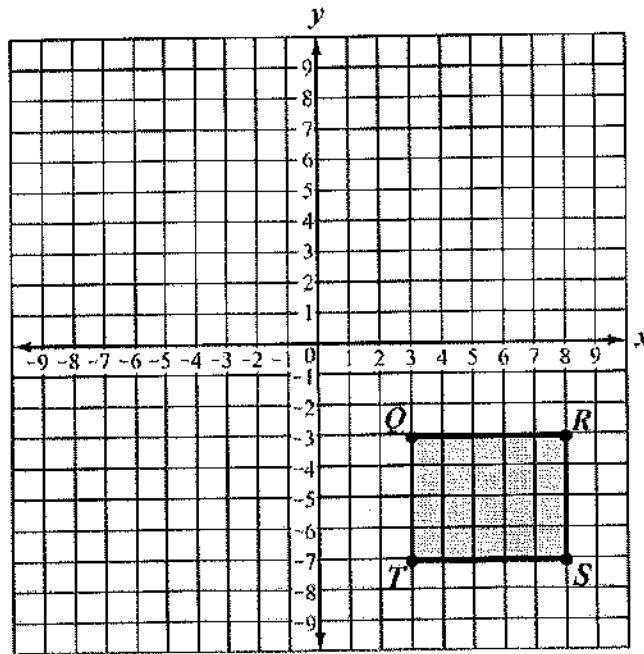

- a. If rectangle $QRST$ is translated so that the image of point S is the point located at $(-3, -6)$, what are the coordinates of the image of point Q ? Show or explain how you got your answer.

On the grid in your Student Answer Booklet, copy the x -axis, the y -axis, and rectangle $QRST$ shown above. Be sure to label points Q , R , S , and T .

- b. Rectangle $Q'R'S'T'$ is the reflection of rectangle $QRST$ over the x -axis. On your grid, draw rectangle $Q'R'S'T'$. Be sure to label points Q' , R' , S' , and T' .
- c. Rectangle $Q''R''S''T''$ is the reflection of rectangle $Q'R'S'T'$ over the y -axis. On your grid, draw rectangle $Q''R''S''T''$. Be sure to label points Q'' , R'' , S'' , and T'' .
- d. As shown from parts (b) and (c), rectangle $Q''R''S''T''$ is the result of two reflections of rectangle $QRST$. It is also the result of one rotation of rectangle $QRST$ about the origin. What is the angle of rotation? Show or explain how you got your answer.



- 1 The rectangle below is a cross section of a three-dimensional object.

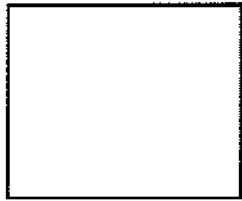

Mark your answer here: 1. (A)(B)(C)(D)

The rectangle could **not** be a cross section of which of the following objects?

- A. a cylinder
- B. a prism
- C. a cube
- D. a cone

- 2 A three-dimensional solid is projected onto a plane. The projection is shown below.

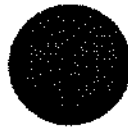

Mark your answer here: 2. (A)(B)(C)(D)

Which of the following could **not** be the three-dimensional solid?

- A. a cone
- B. a prism
- C. a sphere
- D. a cylinder



- 3** The diagrams below show the top view and the front view of a solid object.

Mark your answer here: 3. A B C D

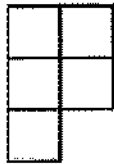

Top view

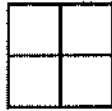

Front view

Which of the following could be a diagram of the solid object?

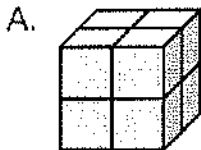

Front

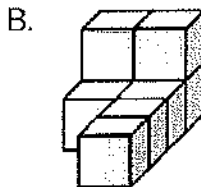

Front

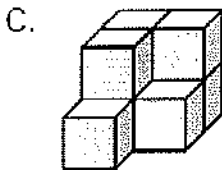

Front

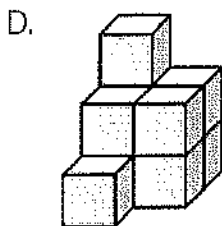

Front



- 1 The vertex-edge graph below represents all the paths in a park.

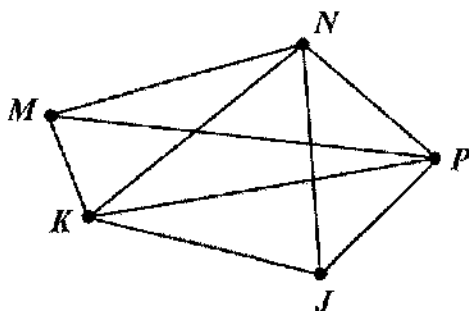

Mark your answer here: 1. (A)(B)(C)(D)

Mike is at point *J* and wants to walk along each path **exactly** one time. At which point will Mike finish his walk?

- A. point *K*
- B. point *M*
- C. point *N*
- D. point *P*



- 2** The vertex-edge graph below shows the highway distances, in miles, between several different cities.

Mark your answer here: 2. (A)(B)(C)(D)

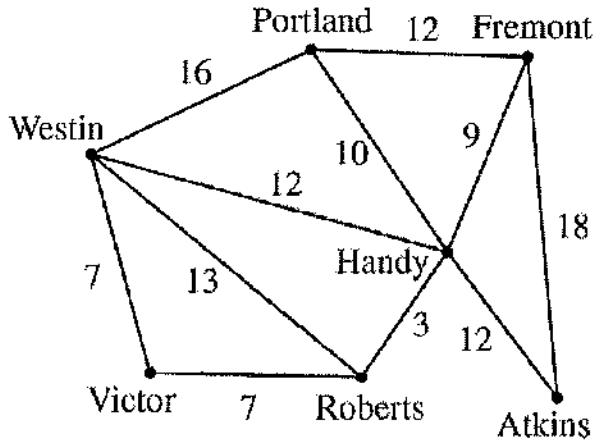

If Susan is traveling by car from Westin to Fremont, which of the following routes would be the shortest?

- A. Westin to Roberts to Handy to Fremont
- B. Westin to Portland to Fremont
- C. Westin to Victor to Roberts to Handy to Fremont
- D. Westin to Handy to Fremont



AREA FORMULAS

square $A = s^2$

rectangle $A = bh$

parallelogram $A = bh$

triangle $A = \frac{1}{2}bh$

trapezoid $A = \frac{1}{2}h(b_1 + b_2)$

circle $A = \pi r^2$

LATERAL SURFACE AREA FORMULAS

right rectangular prism $LA = 2(hw) + 2(lh)$

right circular cylinder $LA = 2\pi rh$

right circular cone $LA = \pi r\ell$
(ℓ = slant height)

right square pyramid $LA = 2s\ell$
(ℓ = slant height)

TOTAL SURFACE AREA FORMULAS

cube $SA = 6s^2$

right rectangular prism $SA = 2(hw) + 2(lw) + 2(lh)$

sphere $SA = 4\pi r^2$

right circular cylinder $SA = 2\pi r^2 + 2\pi rh$

right circular cone $SA = \pi r^2 + \pi r\ell$
(ℓ = slant height)

right square pyramid $SA = s^2 + 2s\ell$
(ℓ = slant height)

VOLUME FORMULAS

cube $V = s^3$
(s = length of an edge)

right rectangular prism $V = lwh$

OR

$V = Bh$
(B = area of a base)

sphere $V = \frac{4}{3}\pi r^3$

right circular cylinder $V = \pi r^2 h$

right circular cone $V = \frac{1}{3}\pi r^2 h$

right square pyramid $V = \frac{1}{3}s^2 h$

CIRCLE FORMULAS

$C = 2\pi r$

$A = \pi r^2$

SPECIAL RIGHT TRIANGLES

