

A Story of Units

Pleasanton
UNIFIED SCHOOL DISTRICT

Mathematics Curriculum



Grade 4 • MODULE 4

Angle Measure and Plane Figures

homework

Video tutorials: <http://embarc.online>

Info for parents: <http://bit.ly/pusdmath>

Version 3



Table of Contents

GRADE 4 • MODULE 4

Angle Measure and Plane Figures

Module Overview	2
Topic A: Lines and Angles	11
Topic B: Angle Measurement	71
Mid-Module Assessment and Rubric	131
Topic C: Problem Solving with the Addition of Angle Measures	145
Topic D: Two-Dimensional Figures and Symmetry	184
End-of-Module Assessment and Rubric	255
Answer Key	269

Name _____

Date _____

1. Use the following directions to draw a figure in the box to the right.
 - a. Draw two points: W and X .
 - b. Use a straightedge to draw \overline{WX} .
 - c. Draw a new point that is not on \overline{WX} . Label it Y .
 - d. Draw \overline{WY} .
 - e. Draw a point not on \overline{WX} or \overline{WY} . Call it Z .
 - f. Construct \overleftrightarrow{YZ} .
 - g. Use the points you've already labeled to name one angle. _____

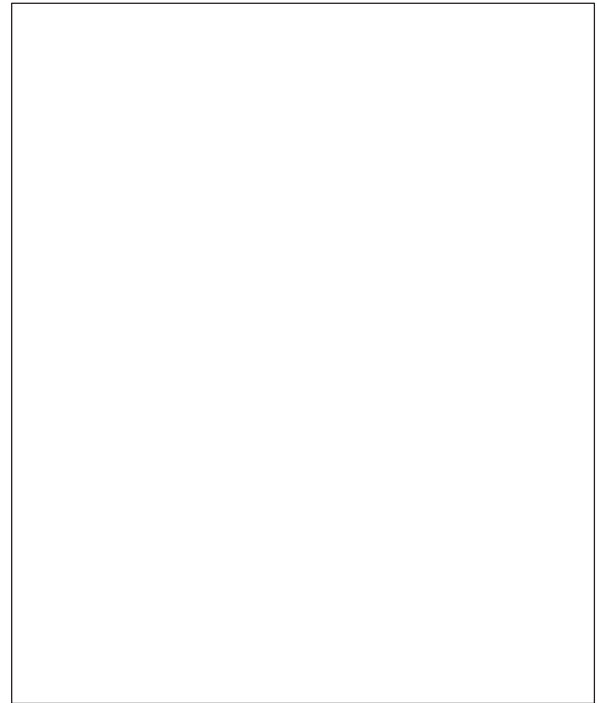

2. Use the following directions to draw a figure in the box to the right.
 - a. Draw two points: W and X .
 - b. Use a straightedge to draw \overline{WX} .
 - c. Draw a new point that is not on \overline{WX} . Label it Y .
 - d. Draw \overline{WY} .
 - e. Draw a new point that is not on \overline{WY} or on the line containing \overline{WX} . Label it Z .
 - f. Construct \overleftrightarrow{WZ} .
 - g. Identify $\angle ZWX$ by drawing an arc to indicate the position of the angle.
 - h. Identify another angle by referencing points that you have already drawn. _____

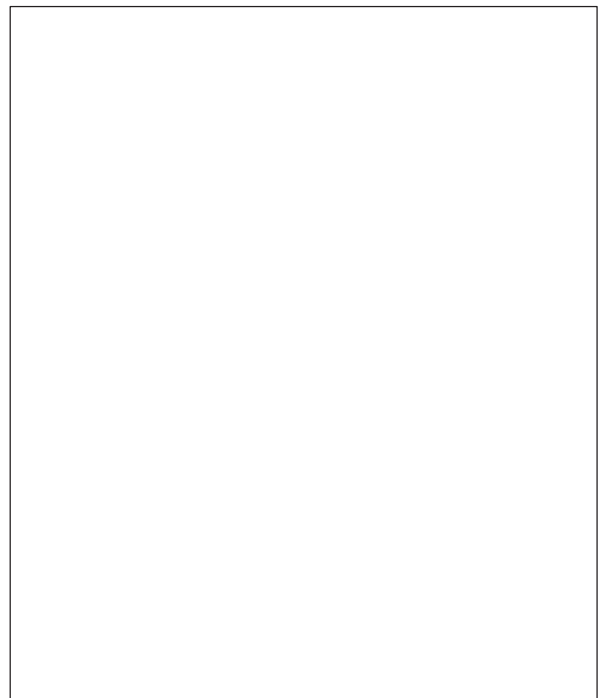

3. a. Observe the familiar figures below. Label some points on each figure.
- b. Use those points to label and name representations of each of the following in the table below: ray, line, line segment, and angle. Extend segments to show lines and rays.



	Clock	Die	Number line
Ray			
Line			
Line segment			
Angle			

Extension: Draw a familiar figure. Label it with points, and then identify rays, lines, line segments, and angles as applicable.

Name _____

Date _____

1. Use the right angle template that you made in class to determine if each of the following angles is greater than, less than, or equal to a right angle. Label each as *greater than*, *less than*, or *equal to*, and then connect each angle to the correct label of acute, right, or obtuse. The first one has been completed for you.

a.

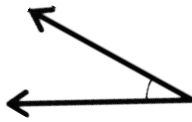

Less than

c.

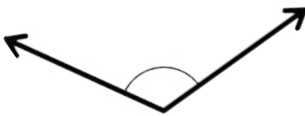

● Acute ●

e.

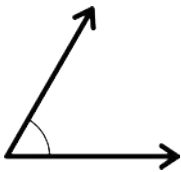

● Right ●

g.

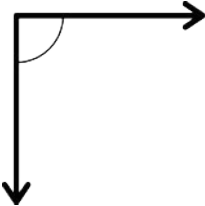

● Obtuse ●

i.

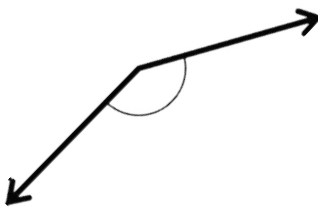

b.

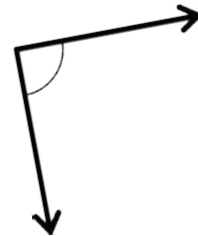

d.



f.

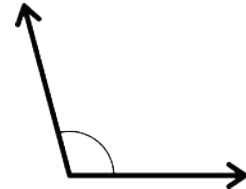

h.



j.



2. Use your right angle template to identify acute, obtuse, and right angles within this painting. Trace at least two of each, label with points, and then name them in the table below the painting.

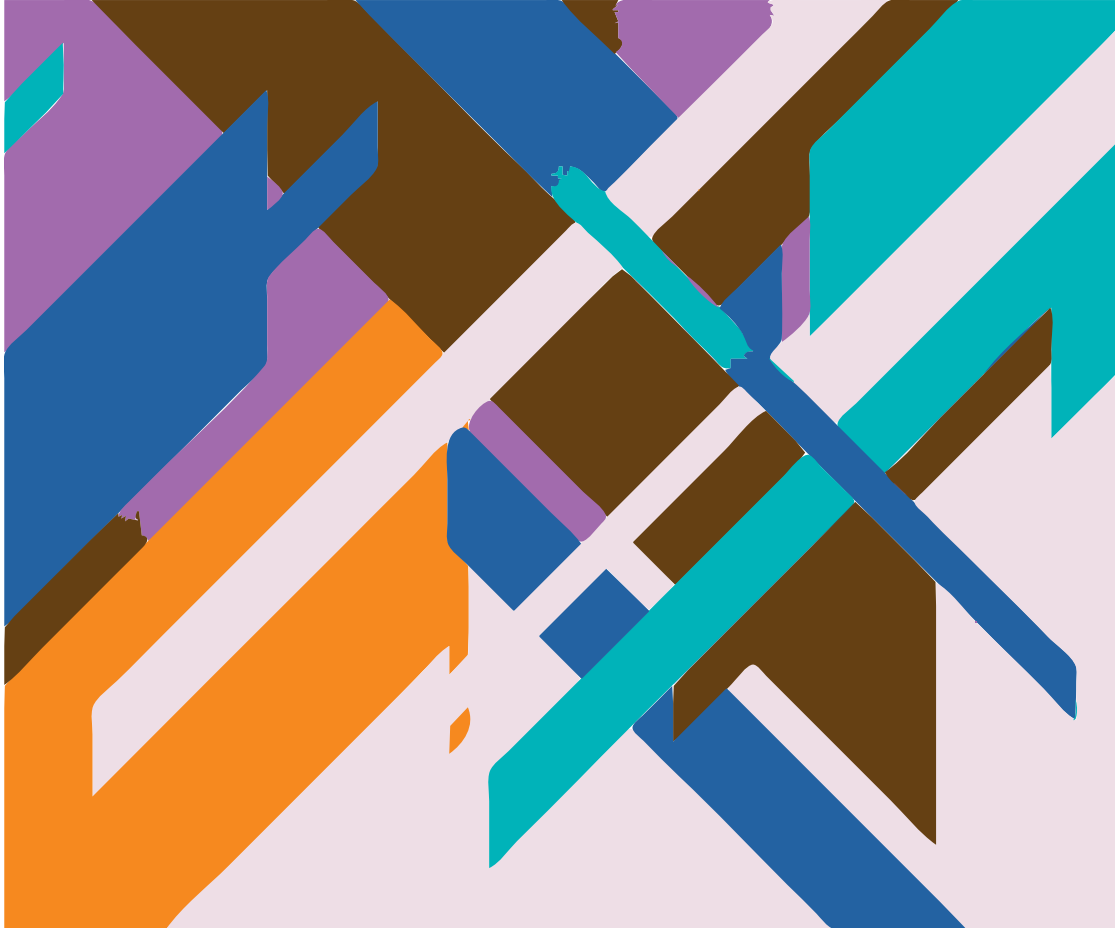

Acute angle		
Obtuse angle		
Right angle		

3. Construct each of the following using a straightedge and the right angle template that you created. Explain the characteristics of each by comparing the angle to a right angle. Use the words *greater than*, *less than*, or *equal to* in your explanations.

a. Acute angle

b. Right angle

c. Obtuse angle

Name _____

Date _____

1. On each object, trace at least one pair of lines that appear to be perpendicular.

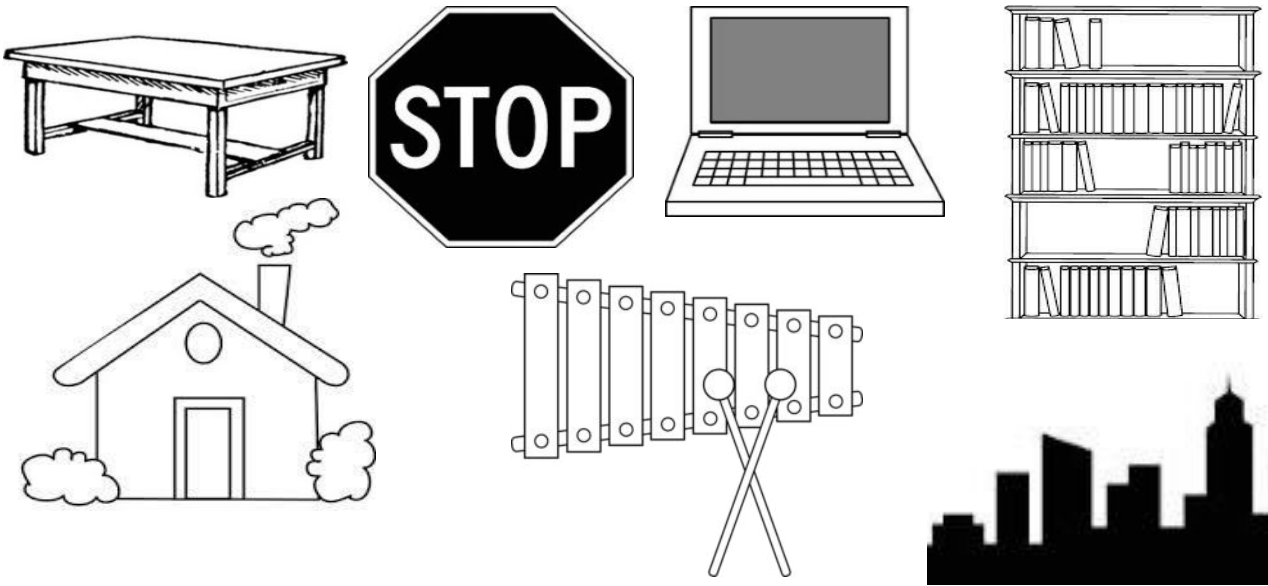

2. How do you know if two lines are perpendicular?

3. In the square and triangular grids below, use the given segments in each grid to draw a segment that is perpendicular. Use a straightedge.

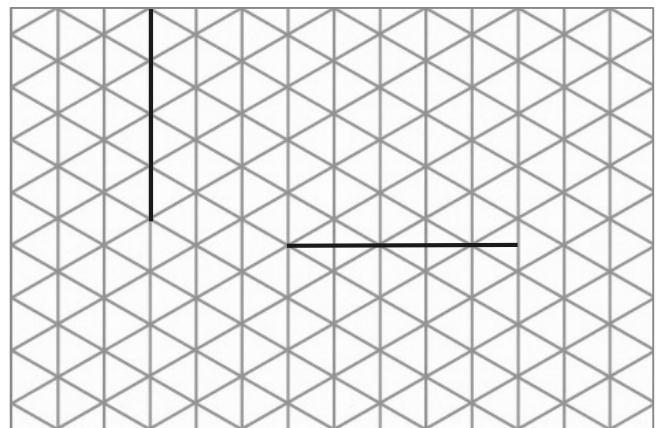
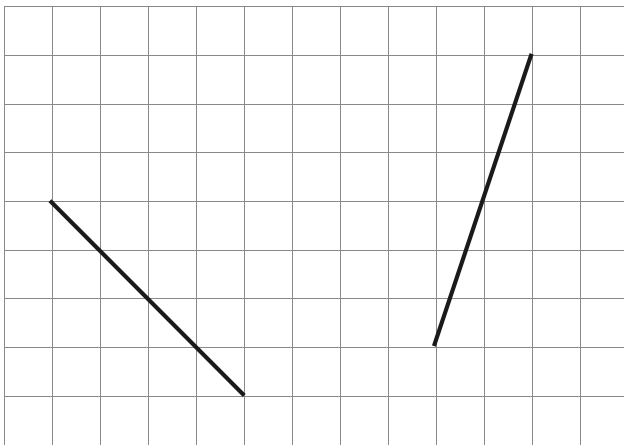

4. Use the right angle template that you created in class to determine which of the following figures have a right angle. Mark each right angle with a small square. For each right angle you find, name the corresponding pair of perpendicular sides. (Problem 4(a) has been started for you.)

a.

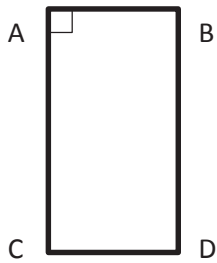

$$\overline{CA} \perp \overline{AB}$$

b.

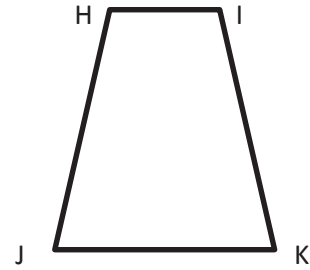

c.

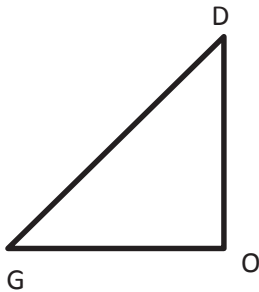

d.

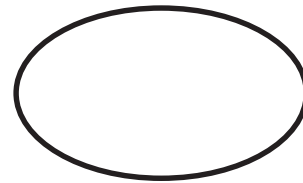

e.

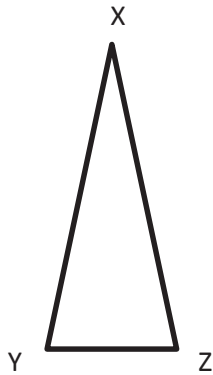

f.

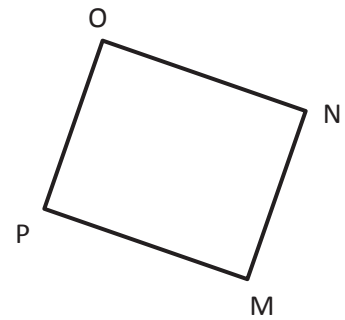

g.



h.

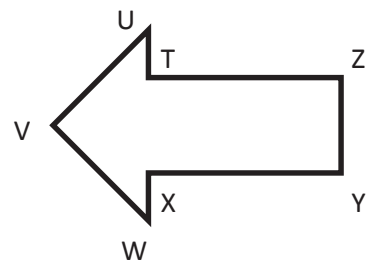

5. Use your right angle template as a guide, and mark each right angle in the following figure with a small square. (Note: A right angle does not have to be inside the figure.) How many pairs of perpendicular sides does this figure have?

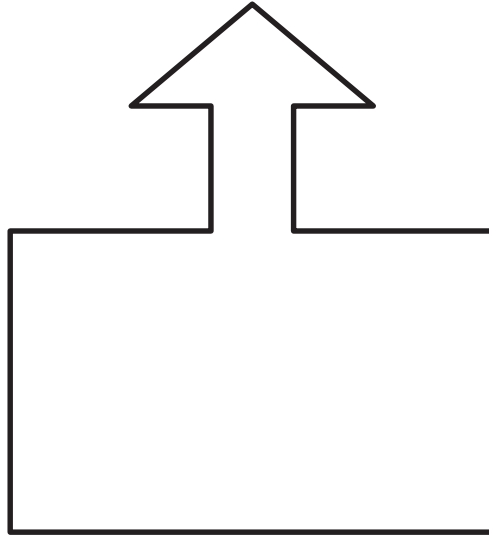

6. True or false? Shapes that have no right angles also have no perpendicular segments. Draw some figures to help explain your thinking.

Name _____

Date _____

1. On each object, trace at least one pair of lines that appear to be parallel.

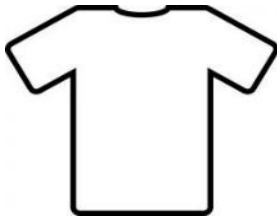

2. How do you know if two lines are parallel?

3. In the square and triangular grids below, use the given segments in each grid to draw a segment that is parallel using a straightedge.

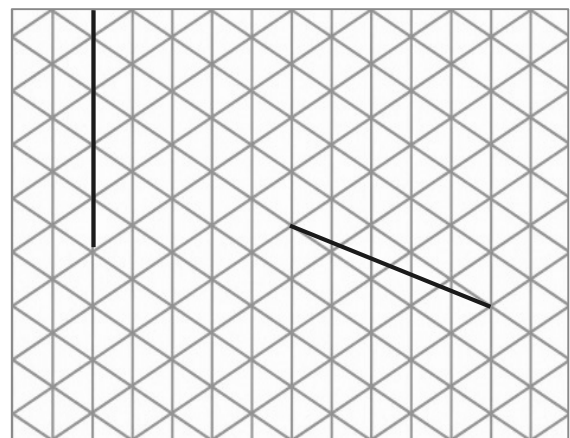

4. Determine which of the following figures have sides that are parallel by using a straightedge and the right angle template that you created. Circle the letter of the shapes that have at least one pair of parallel sides. Mark each pair of parallel sides with arrows, and then identify the parallel sides with a statement modeled after the one in 4(a).

a.

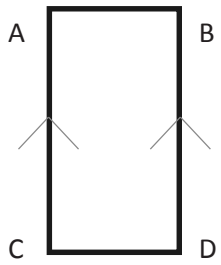

$$\overline{AC} \parallel \overline{BD}$$

b.

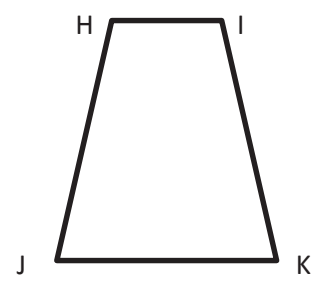

c.

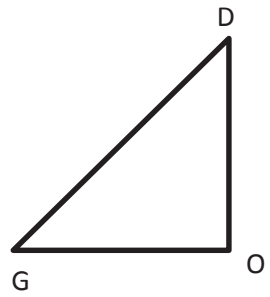

d.

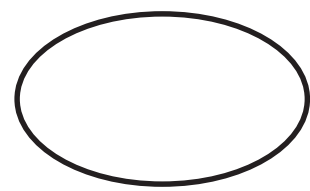

e.

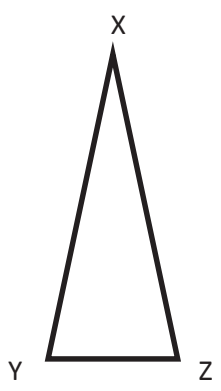

f.

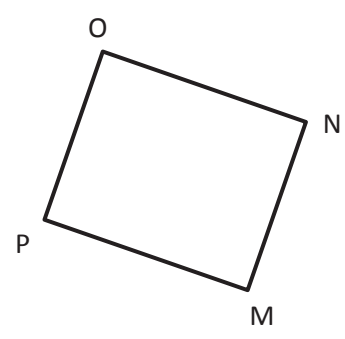

g.



h.

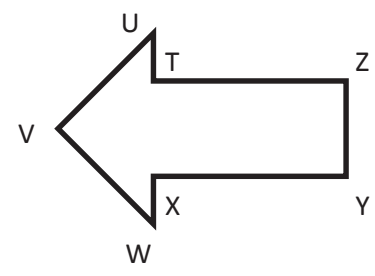

5. True or false? All shapes with a right angle have sides that are parallel. Explain your thinking.

6. Explain why \overline{AB} and \overline{CD} are parallel, but \overline{EF} and \overline{GH} are not.

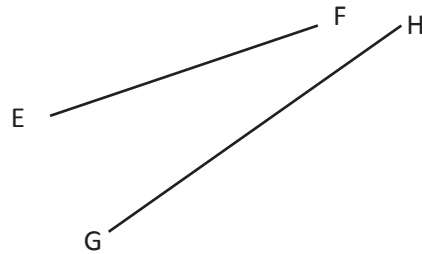

7. Draw a line using your straightedge. Now, use your right angle template and straightedge to construct a line parallel to the first line you drew.

Name _____

Date _____

1. Identify the measures of the following angles.

a.

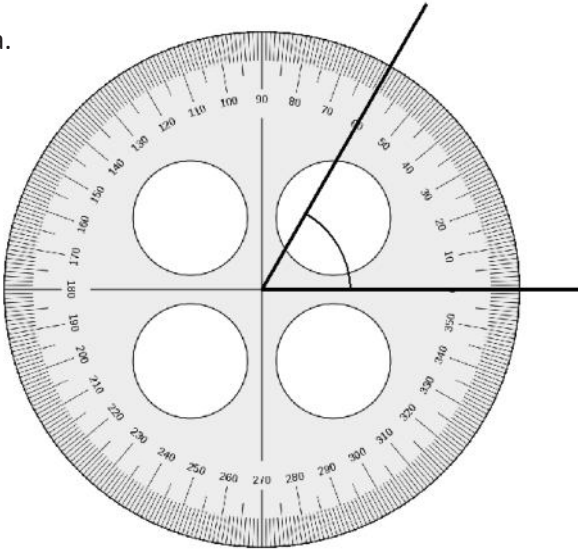

b.

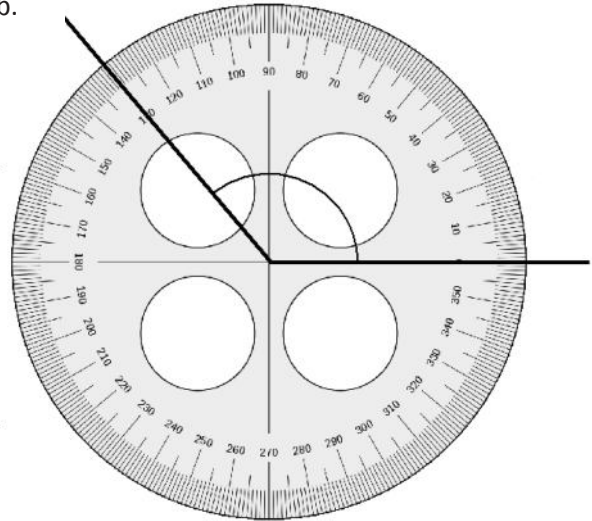

c.

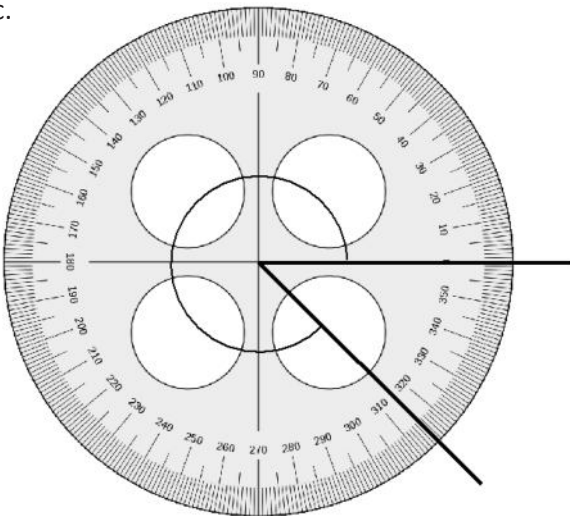

d.

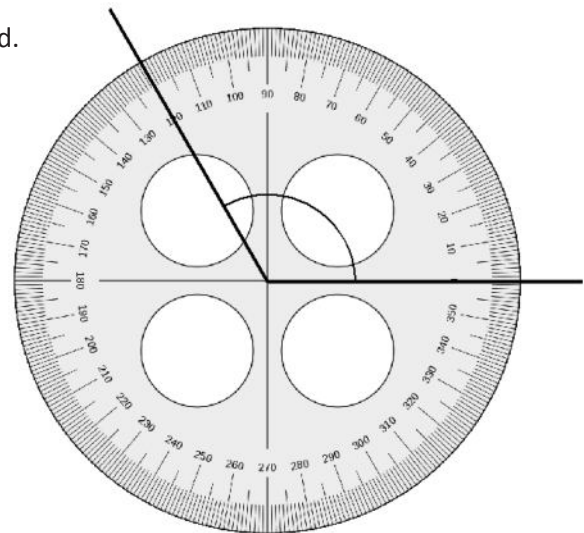

2. If you didn't have a protractor, how could you construct one? Use words, pictures, or numbers to explain in the space below.

Name _____

Date _____

1. Use a protractor to measure the angles, and then record the measurements in degrees.

a.



b.

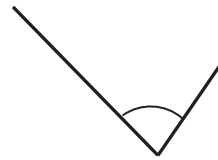

c.

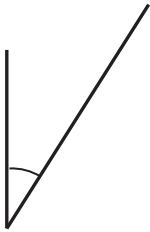

d.

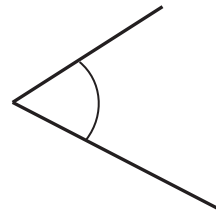

e.



f.



g.

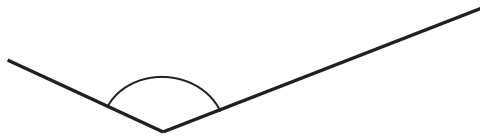

h.

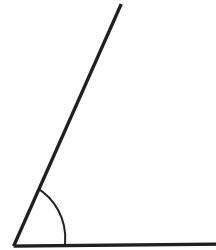

i.

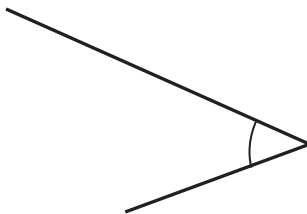

j.

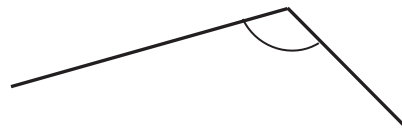

2. Using the green and red circle cutouts from today's lesson, explain to someone at home how the cutouts can be used to show that the angle measures are the same even though the circles are different sizes. Write words to explain what you told him or her.

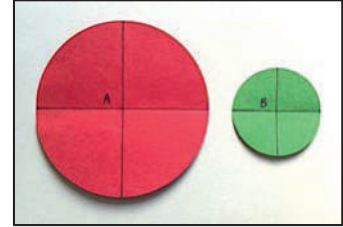

3. Use a protractor to measure each angle. Extend the length of the segments as needed. When you extend the segments, does the angle measure stay the same? Explain how you know.

a.



b.

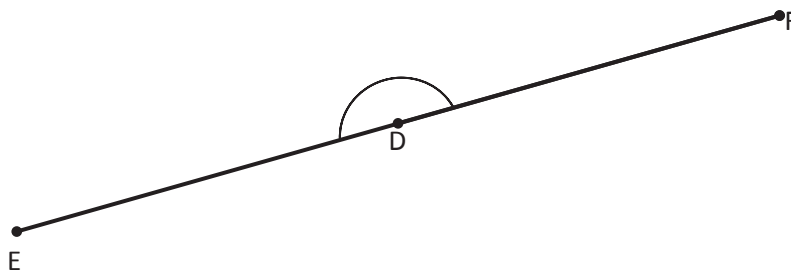

Name _____

Date _____

Construct angles that measure the given number of degrees. For Problems 1–4, use the ray shown as one of the rays of the angle with its endpoint as the vertex of the angle. Draw an arc to indicate the angle that was measured.

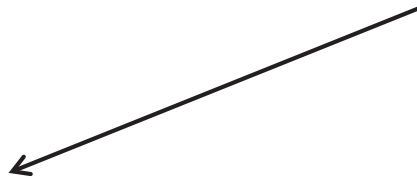
1. 25° 2. 85° 3. 140° 4. 83° 

5. 108° 6. 72° 7. 25° 8. 155° 9. 45° 10. 135°

Name _____

Date _____

1. Jill, Shyan, and Barb stood in the middle of the yard and faced the barn. Jill turned 90° to the right. Shyan turned 180° to the left. Barb turned 270° to the left. Name the object that each girl is now facing.

Jill _____

Shyan _____

Barb _____

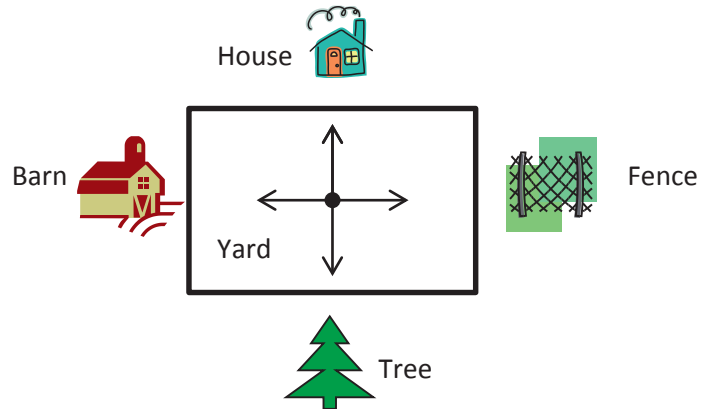

2. Allison looked at the clock at the beginning of class and at the end of class. How many degrees did the minute hand turn from the beginning of class until the end?



Beginning



End

3. The snowboarder went off a jump and did a 180° . In which direction was the snowboarder facing when he landed? How do you know?
4. As she drove down the icy road, Mrs. Campbell slammed on her brakes. Her car did a 360° . Explain what happened to Mrs. Campbell's car.

5. Jonah turned the knob of the stove two quarter-turns. Draw a picture showing the position of the knob after he turned it.

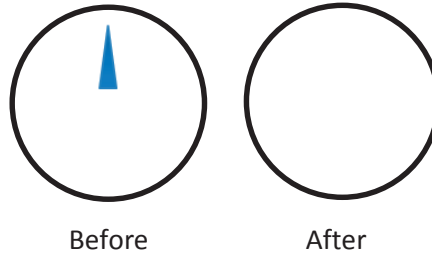

6. Betsy used her scissors to cut out a coupon from the newspaper. How many total quarter-turns will she need to rotate the paper in order to cut out the entire coupon?



7. How many quarter-turns does the picture need to be rotated in order for it to be upright?

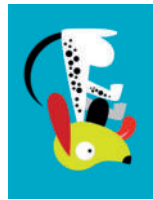

8. David faced north. He turned 180° to the right, and then 270° to the left. In which direction is he now facing?

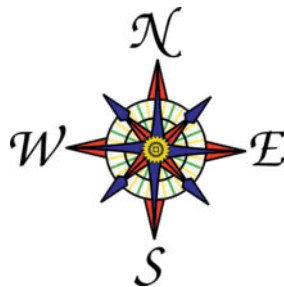

Name _____

Date _____

Sketch two different ways to compose the given angles using two or more pattern blocks. Write an addition sentence to show how you composed the given angle.

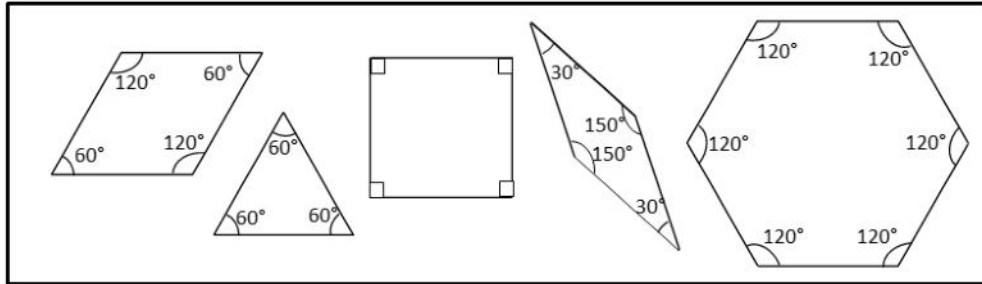

1. Points A , B , and C form a straight line.

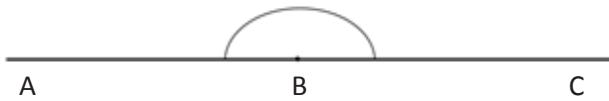

$180^\circ =$ _____

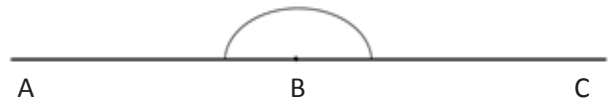

$180^\circ =$ _____

2. $\angle DEF = 90^\circ$

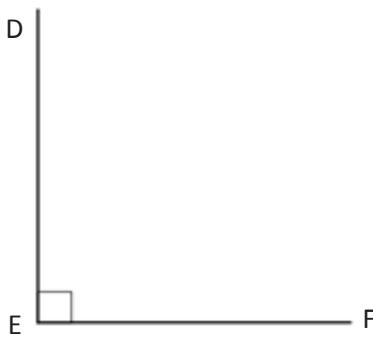

$90^\circ =$ _____

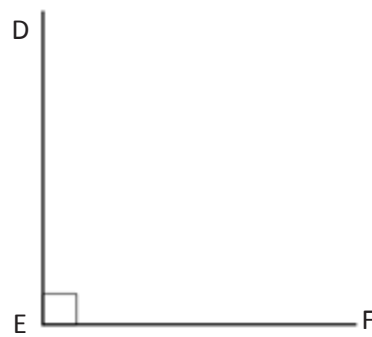

$90^\circ =$ _____

3. $\angle GHI = 120^\circ$

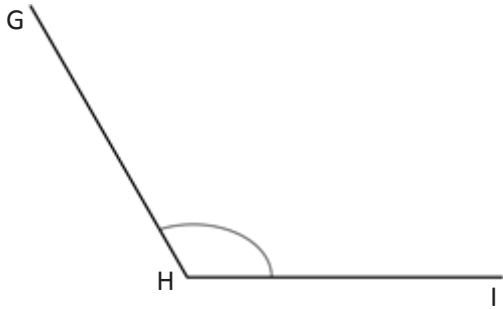

$120^\circ =$ _____

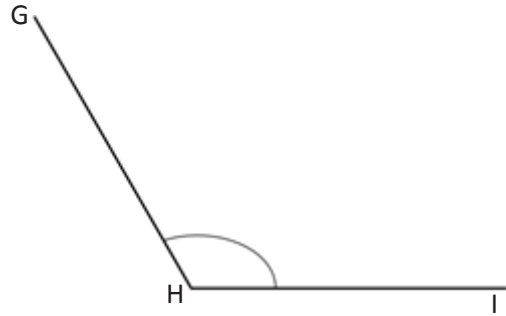

$120^\circ =$ _____

4. $x^\circ = 270^\circ$

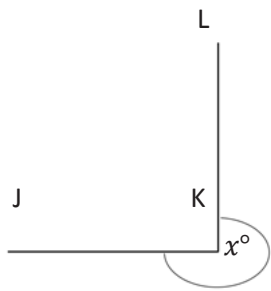

$270^\circ =$ _____

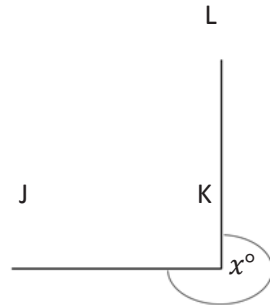

$270^\circ =$ _____

5. Micah built the following shape with his pattern blocks. Write an addition sentence for each angle indicated by an arc and solve. The first one is done for you.

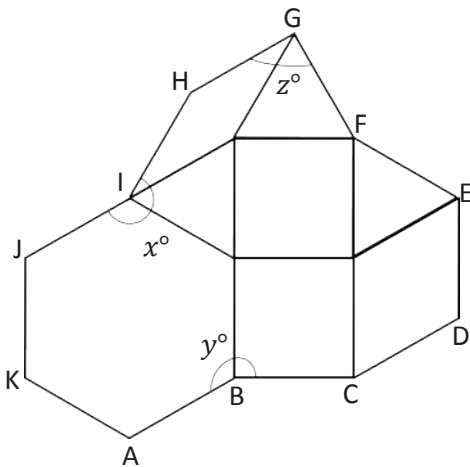

a. $y^\circ = 120^\circ + 90^\circ$

$y^\circ = 210^\circ$

b. $z^\circ =$ _____

$z^\circ =$ _____

c. $x^\circ =$ _____

$x^\circ =$ _____

Name _____

Date _____

Write an equation, and solve for the measurement of $\angle x$. Verify the measurement using a protractor.

1. $\angle DCB$ is a right angle.

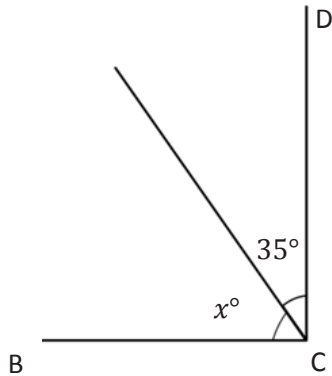

$$\underline{\hspace{2cm}} + 35^\circ = 90^\circ$$

$$x^\circ = \underline{\hspace{2cm}}$$

2. $\angle HGF$ is a right angle.

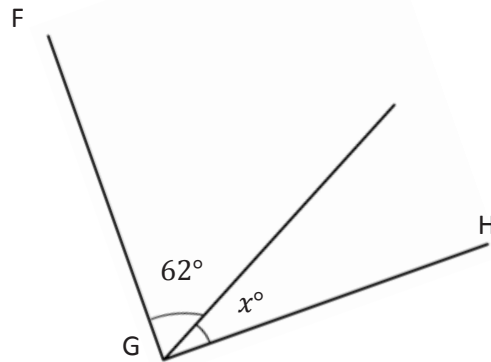

$$\underline{\hspace{2cm}} + \underline{\hspace{2cm}} = \underline{\hspace{2cm}}$$

$$x^\circ = \underline{\hspace{2cm}}$$

3. $\angle JKL$ is a straight angle.

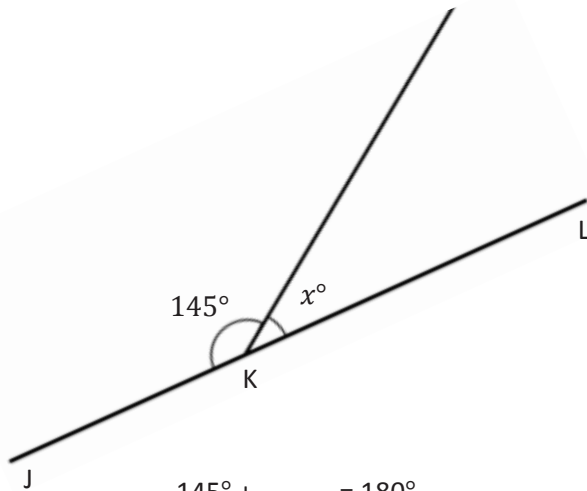

$$145^\circ + \underline{\hspace{2cm}} = 180^\circ$$

$$x^\circ = \underline{\hspace{2cm}}$$

4. $\angle PQR$ is a straight angle.

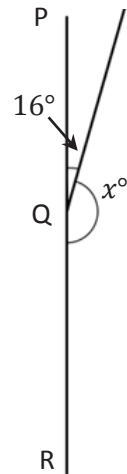

$$\underline{\hspace{2cm}} + \underline{\hspace{2cm}} = \underline{\hspace{2cm}}$$

$$x^\circ = \underline{\hspace{2cm}}$$

Write an equation, and solve for the unknown angle measurements.

5. Solve for the measurement of $\angle USW$.
 $\angle RST$ is a straight angle.

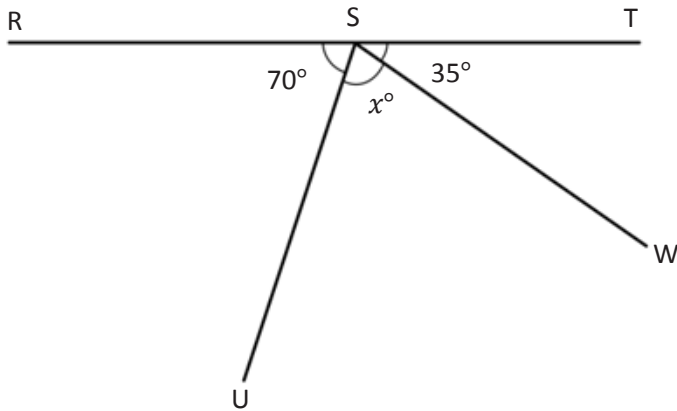

6. Solve for the measurement of $\angle OML$.
 $\angle LMN$ is a straight angle.

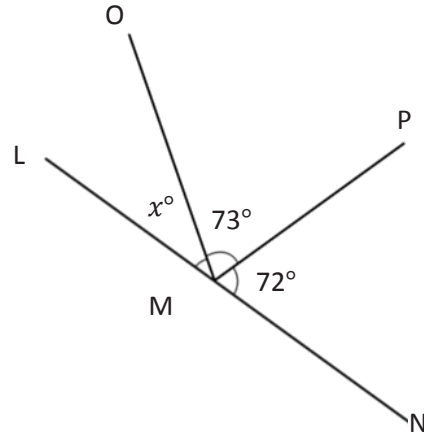

7. In the following figure, $DEFH$ is a rectangle. Without using a protractor, determine the measurement of $\angle GEF$. Write an equation that could be used to solve the problem.



8. Complete the following directions in the space to the right.
- Draw 2 points: Q and R . Using a straightedge, draw \overleftrightarrow{QR} .
 - Plot a point S somewhere between points Q and R .
 - Plot a point T , which is not on \overleftrightarrow{QR} .
 - Draw \overline{TS} .
 - Find the measure of $\angle QST$ and $\angle RST$.
 - Write an equation to show that the angles add to the measure of a straight angle.

Name _____

Date _____

Write an equation, and solve for the unknown angle measurements numerically.

1.

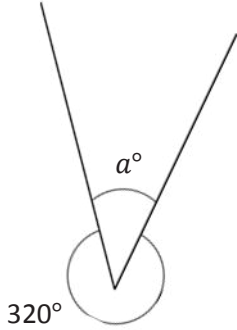

$$\underline{\quad}^{\circ} + 320^{\circ} = 360^{\circ}$$

$$a^{\circ} = \underline{\quad}^{\circ}$$

2.

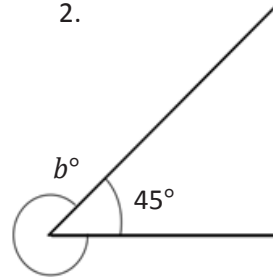

$$\underline{\quad}^{\circ} + \underline{\quad}^{\circ} = 360^{\circ}$$

$$b^{\circ} = \underline{\quad}^{\circ}$$

3.

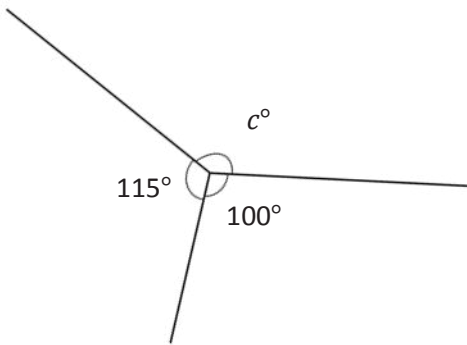

$$\underline{\quad}^{\circ} + \underline{\quad}^{\circ} + \underline{\quad}^{\circ} = \underline{\quad}^{\circ}$$

$$c^{\circ} = \underline{\quad}^{\circ}$$

4.

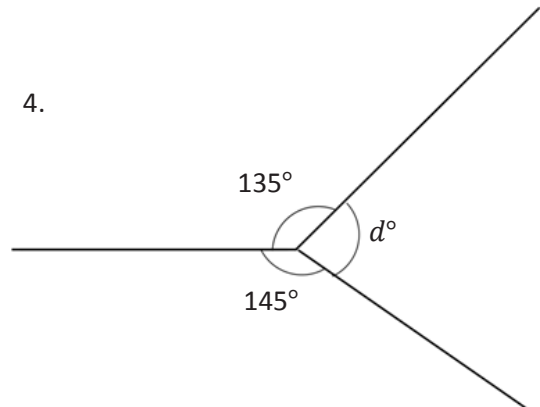

$$\underline{\quad}^{\circ} + \underline{\quad}^{\circ} + \underline{\quad}^{\circ} = \underline{\quad}^{\circ}$$

$$d^{\circ} = \underline{\quad}^{\circ}$$

Write an equation, and solve for the unknown angles numerically.

5. O is the intersection of \overline{AB} and \overline{CD} . $e^\circ = \underline{\hspace{2cm}}$ $f^\circ = \underline{\hspace{2cm}}$
 $\angle COB$ is 145° , and $\angle AOC$ is 35° .

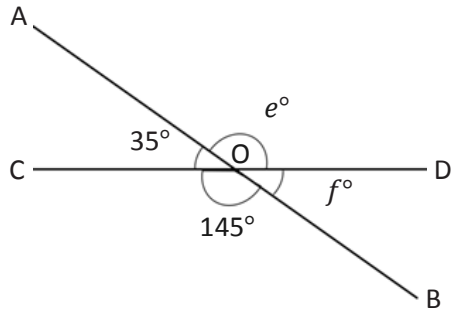

6. O is the intersection of \overline{QR} and \overline{ST} . $g^\circ = \underline{\hspace{2cm}}$ $h^\circ = \underline{\hspace{2cm}}$ $i^\circ = \underline{\hspace{2cm}}$
 $\angle QOS$ is 55° .

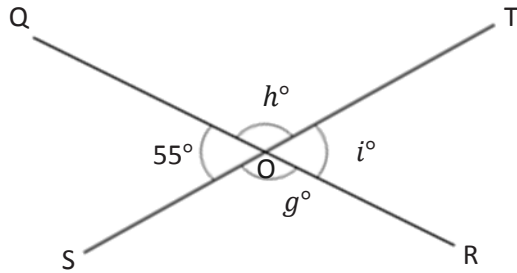

7. O is the intersection of \overline{UV} , \overline{WX} , and \overline{YO} . $j^\circ = \underline{\hspace{2cm}}$ $k^\circ = \underline{\hspace{2cm}}$ $m^\circ = \underline{\hspace{2cm}}$
 $\angle VOX$ is 46° .

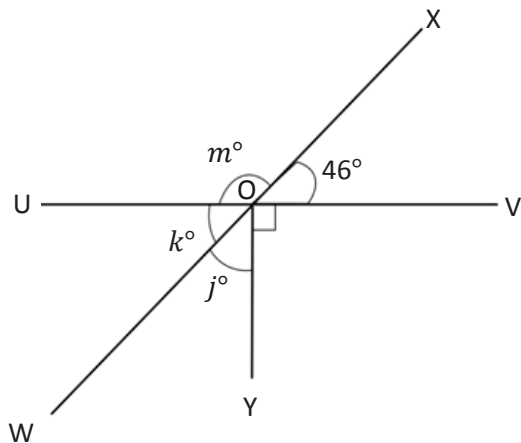

Name _____

Date _____

1. Circle the figures that have a correct line of symmetry drawn.

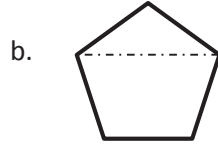
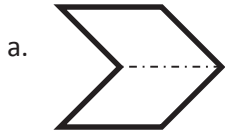

2. Find and draw all lines of symmetry for the following figures. Write the number of lines of symmetry that you found in the blank underneath the shape.

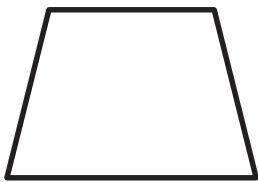

a. _____

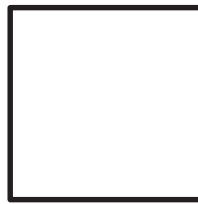

b. _____

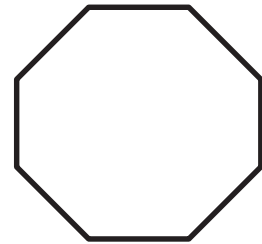

c. _____

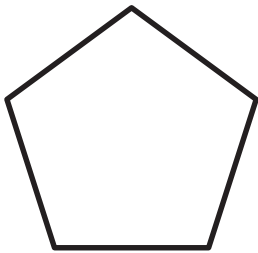

d. _____

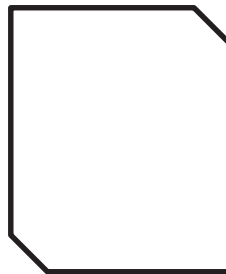

e. _____

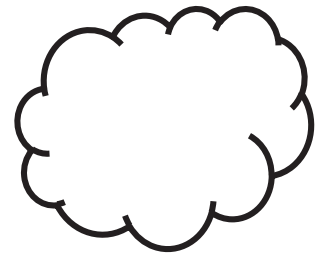

f. _____

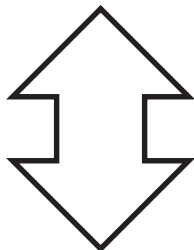

g. _____



h. _____

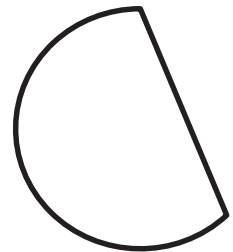

i. _____

3. Half of each figure below has been drawn. Use the line of symmetry, represented by the dashed line, to complete each figure.

a.

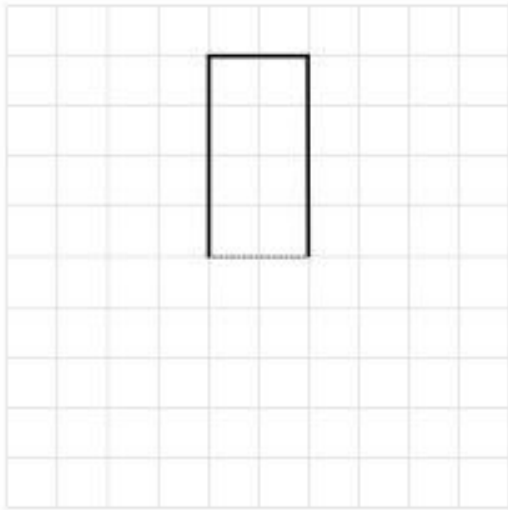

b.

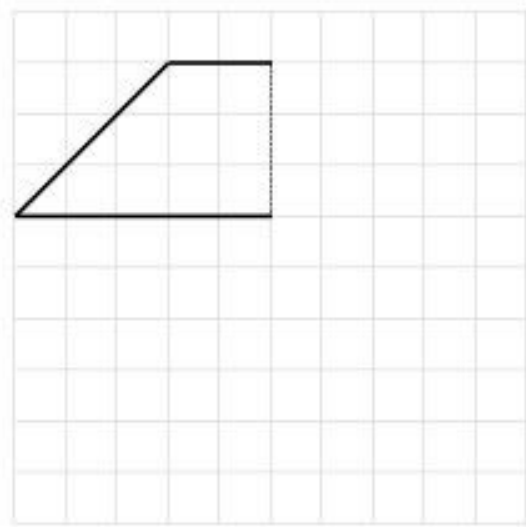

c.

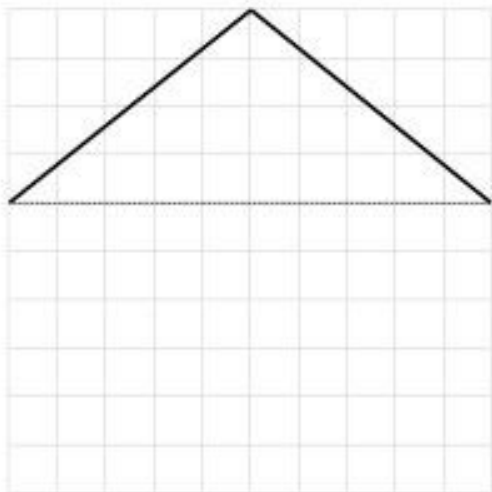

d.

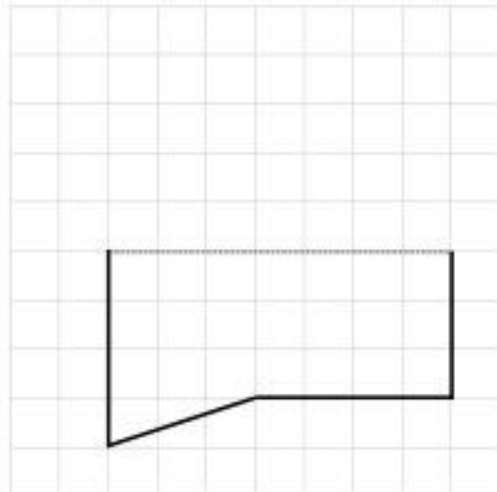

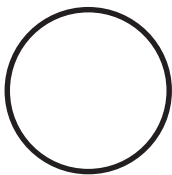

4. Is there another shape that has the same number of lines of symmetry as a circle? Explain.



Name _____

Date _____

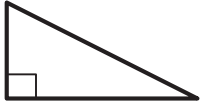
1. Classify each triangle by its side lengths and angle measurements. Circle the correct names.

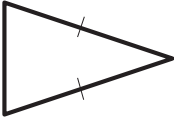
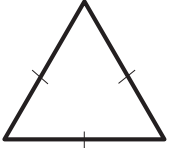
	Classify Using Side Lengths	Classify Using Angle Measurements
a. 	Equilateral Isosceles Scalene	Acute Right Obtuse
b. 	Equilateral Isosceles Scalene	Acute Right Obtuse
c. 	Equilateral Isosceles Scalene	Acute Right Obtuse
d. 	Equilateral Isosceles Scalene	Acute Right Obtuse

2. a. $\triangle ABC$ has one line of symmetry as shown. Is the measure of $\angle A$ greater than, less than, or equal to $\angle C$?

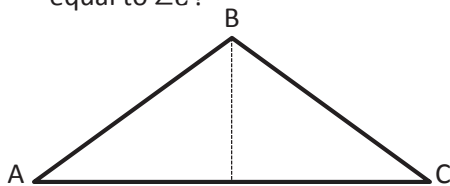

- b. $\triangle DEF$ is scalene. What do you observe about its angles? Explain.

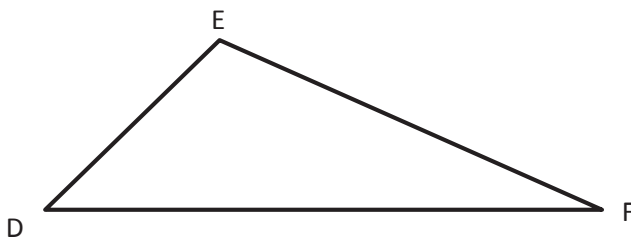

3. Use a ruler to connect points to form two other triangles. Use each point only once. None of the triangles may overlap. Two points will be unused. Name and classify the three triangles below.

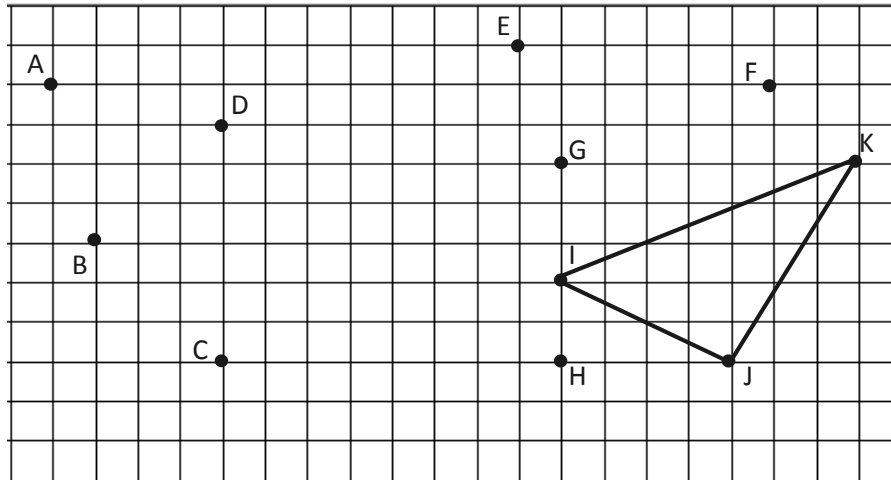

Name the Triangles Using Vertices	Classify by Side Length	Classify by Angle Measurement
$\triangle IJK$		

4. If the perimeter of an equilateral triangle is 15 cm, what is the length of each side?
5. Can a triangle have more than one obtuse angle? Explain.
6. Can a triangle have one obtuse angle and one right angle? Explain.

Name _____

Date _____

1. Draw triangles that fit the following classifications. Use a ruler and protractor. Label the side lengths and angles.
 - a. Right and isosceles
 - b. Right and scalene
 - c. Obtuse and isosceles
 - d. Acute and scalene

2. Draw all possible lines of symmetry in the triangles above. Explain why some of the triangles do not have lines of symmetry.

Are the following statements true or false? Explain.

3. $\triangle ABC$ is an isosceles triangle. \overline{AB} must be 2 cm. True or False?

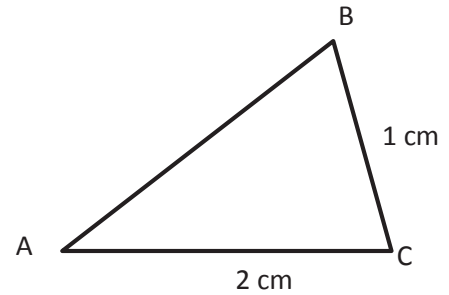

4. A triangle cannot have both an acute angle and a right angle. True or False?

5. $\triangle XYZ$ can be described as both equilateral and acute. True or False?

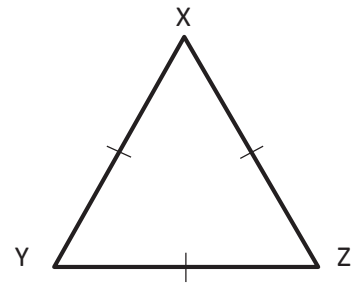

6. A right triangle is always scalene. True or False?

Extension: In $\triangle ABC$, $x = y$. True or False?

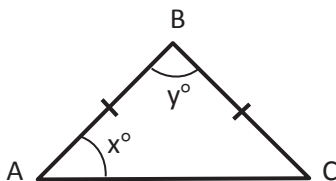

Name _____

Date _____

1. Use the word bank to name each shape, being as specific as possible.

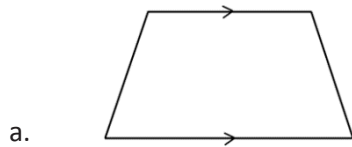
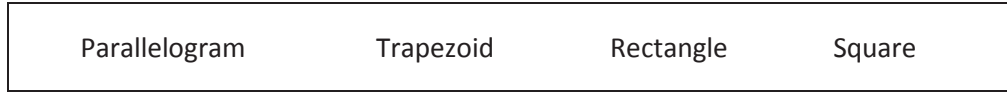

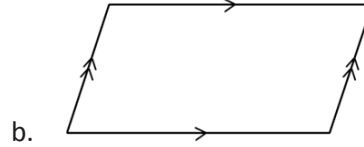

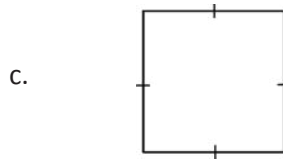

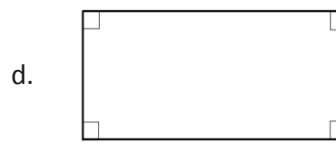

2. Explain the attribute that makes a square a special rectangle.
3. Explain the attribute that makes a rectangle a special parallelogram.
4. Explain the attribute that makes a parallelogram a special trapezoid.

5. Construct the following figures based on the given attributes. Give a name to each figure you construct. Be as specific as possible.
- a. A quadrilateral with four sides the same length and four right angles.
 - b. A quadrilateral with two sets of parallel sides.
 - c. A quadrilateral with only one set of parallel sides.
 - d. A parallelogram with four right angles.

Name _____

Date _____

Use the grid to construct the following. Name the figure you drew using one of the terms in the word box.

1. Construct a quadrilateral with only one set of parallel sides.

Which shape did you create?

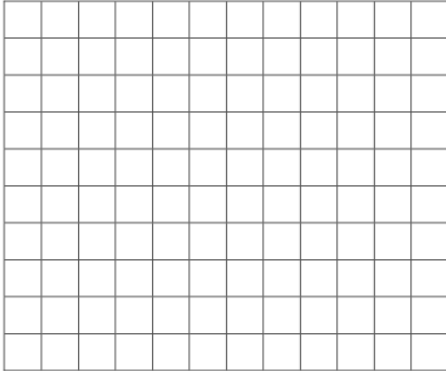
**WORD BOX**

Parallelogram

Trapezoid

Rectangle

Square

Rhombus

2. Construct a quadrilateral with one set of parallel sides and two right angles.

Which shape did you create?

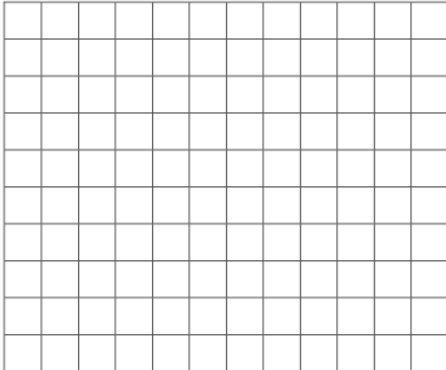

3. Construct a quadrilateral with two sets of parallel sides.

Which shape did you create?

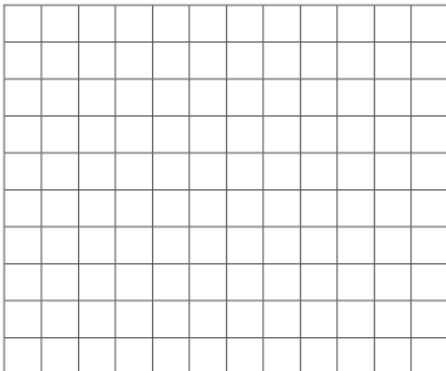

4. Construct a quadrilateral with all sides of equal length.
Which shape did you create?

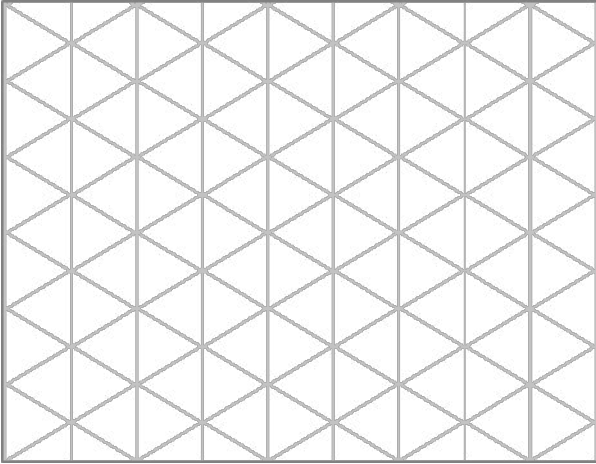

5. Construct a rectangle with all sides of equal length.
Which shape did you create?

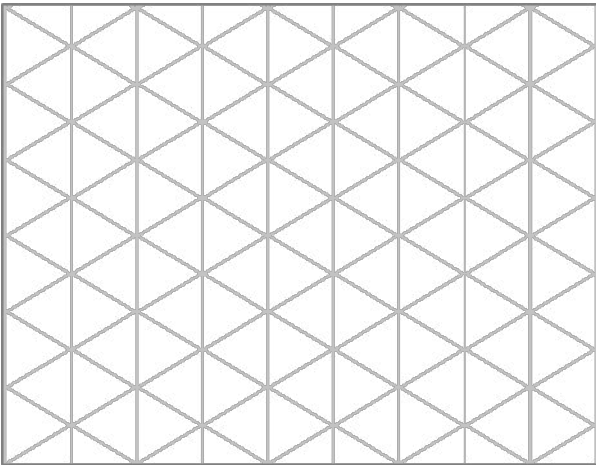





Video tutorials: <http://embarc.online>
Info for parents: <http://bit.ly/pusdmath>