

Water Chemistry of Lakes in the Southwest Florida Water Management District



Kenneth Romie
Environmental Section
Resource Management Department

Southwest Florida
Water Management District
February 2000



Acknowledgments

This report was made possible by the invaluable contribution of all those that helped with every aspect of study. They included:

Data Collection

Quincy Wylupek
Keith Kolasa
Philip Rhinesmith
David Carr
Lisa Henningsen
Richard Gant
Marcella Robinson
Matthew Dooris
Sid Flannery
Craig Dye
Mark Kehoe
Mark Hurst

GIS Data and Analysis

Phil Jackson

Cover Art and Photography

Richard Gant

Water Chemistry Analysis

Mark Rials
Jackie Hohman
Bonnie Gering
Gerry Hall
John Boutin
Matt Jablonski
Addys Cortes
Ying Wu
Lynn Olsen
Scott McDermott
Jason Hood
Michael Carta
Forrest Sackey
Lonnie Lewis

Table of Contents

Acknowledgments	i
Table of Contents	ii
List of Tables	iii
List of Figures	iv
Introduction	1
Site Selection	2
Sampling Methods	3
Data Analysis	3
Data Summary	4
Percentile Distributions of Water Chemistry for the Sampled Lakes	5
Ionic Compositions of the Sampled Lakes	7
Water Chemistry and Soils	8
Water Chemistry and Land Use	10
Water Chemistry and Florida Lake Region	11
Literature Cited	59
<u>Appendix A.</u> List of Lakes Sampled in the Southwest Florida Water Management District	62
<u>Appendix B.</u> Plots Depicting the Water Chemistry Sample Distributions for Lakes Sampled in the Southwest Florida Water Management District	70
<u>Appendix C.</u> Lake Water Chemistry vs. Soil Series, for 323 Sampled Lakes in the Southwest Florida Water Management District	83

Appendix D. Lake Water Chemistry vs. Land Use, for 323 Sampled Lakes in the Southwest Florida Water Management District 104

Appendix E. Data Summary Sheets for Lakes Sampled in the Southwest Florida Water Management District. 125

- a. Interpretation of Water Chemistry Measures* 126
- b. Interpretation of Lake Data Sheets* 128
- b. Interpretation of Water Chemistry and Lake Surface Elevation Plots* 129
- c. Data summary sheets* 129

List of Tables

Table 1. Locations of the original (1992-1995) Ambient Monitoring Program water bodies and stations	14
Table 2(a). Distribution of sampled lakes by county, for all lakes in the SWFWMD; 2(b), distribution of sampled lakes by county, for all named lakes in the SWFWMD	15
Table 3. Water Chemistry Parameters, Units, Detection Limits, and Analytical Methods Used	16
Table 4. Summary of Water Chemistry for all Sample Lakes	17
Table 5. Summary of Nuisance Vegetation in the Sampled Lakes.	18
Table 6. Dominant Ions in the sampled lakes, determined from concentrations, percent meq/L	19
Table 7. Dominant ions in the sampled lakes, by Florida lake region	20
Table 8. A description of the soil orders	21
Table 9. Summary of soil orders present in the 500 meter buffer areas around the sample lakes (n=323)	22
Table 10. Summary of soil chemistry data, from soil data for soils within the SWFWMD bounds	23
Table 11. Spearman rank correlation coefficients for soil order with median lake water chemistry variables	24
Table 12. Spearman rank correlation coefficients for major land use classifications with median lake water chemistry variables	25
Table 13. Summary of relative lake water chemistry by Florida Lake Region	26

List of Figures

Figure 1. Distribution of Florida trophic state index (FTSI) in the sample lakes	27
Figure 2. Distribution of chlorophyll <i>a</i> in the sample lakes	28
Figure 3. Distribution of color in the sample lakes	29
Figure 4. Distribution of specific conductance in the sample lakes	30
Figure 5. Distribution of total hardness in the sample lakes	31
Figure 6. Distribution of pH in the sample lakes	32
Figure 7. Distribution of transparency (Secchi depth) in the sample lakes	33
Figure 8. Distribution of total nitrogen in the sample lakes	34
Figure 9. Distribution of total alkalinity in the sample lakes	35
Figure 10. Distribution of total phosphorus in the sample lakes	36
Figure 11. Distribution of total suspended solids in the sample lakes	37
Figure 12. Distribution of turbidity in the sample lakes	38
Figure 13. Prevalent chemical type of water in the 323 sample lakes	39
Figure 14. Bar plot of sum of the major ions by lake water chemical type	40
Figure 15. Bar plot of pH by lake water chemical type	41
Figure 16. <i>top</i> - Bar plot of soil total bases by soil order; <i>bottom</i> - Bar plot of soil cation exchange capacity by soil order	42
Figure 17. <i>top</i> - Soil pH by soil order; <i>bottom</i> - Soil organic carbon content by soil order	43
Figure 18. <i>top</i> - Soil total phosphorus by soil order; <i>bottom</i> - Soil hydraulic conductivity by soil order	44
Figure 19. Plots of potassium by Alfisol soil order. The top plot is of raw values, the lower plot is of the ranked values of both potassium and Alfisol area	45

Figure 20. Plots of sodium by Entisol soil order. The top plot is of raw values, the lower plot is of the ranked values of both sodium and Entisol area	46
Figure 21. Plots of color by Histosol soil order. The top plot is of raw values, the lower plot is of the ranked values of both color and Histosol area	47
Figure 22. Plots of potassium and magnesium by grove type land use	48
Figure 23. Plots of sulfate and total hardness by grove type land use	49
Figure 24. Plots of specific conductance and nitrate by grove type land use	50
Figure 25. Bubble plot depicting the interaction between grove land use and Entisol soil order and sample lake nitrate concentrations	51
Figure 26. Map of Florida Lake Regions in the Southwest Florida Water Management District	52
Figure 27. Box plots of turbidity and total suspended solids, vs. Florida Lake Region	53
Figure 28. Box plots of total nitrogen and total phosphorus, vs. Florida Lake Region	54
Figure 29. Box plots of pH and total alkalinity, vs. Florida Lake Region	55
Figure 30. Box plots of chlorophyll <i>a</i> and Florida trophic state index, vs. Florida Lake Region	56
Figure 31. Box plots of nitrate and sulfate, vs. Florida Lake Region	57
Figure 32. Box plots of conductivity and Secchi depth, vs. Florida Lake Region	58

WATER CHEMISTRY OF LAKES IN THE SOUTHWEST FLORIDA WATER MANAGEMENT DISTRICT

Introduction

The Southwest Florida Water Management District (SWFWMD) began an ambient monitoring program for lakes in the District in January 1992. The objectives of the monitoring program were: 1) for early detection of water bodies with declining water quality trends, which might benefit from District or local government intervention; 2) to document changes in water chemistry that could be associated with the implementation of management strategies by the District or local governments; 3) to provide preliminary data for water bodies that may ultimately be included in the Surface Water Improvement and Management Program (SWIM) Priority Waterbody List; and 4), to establish a long-term database for water bodies representative of identifiable geographical and ecological regions that can be used for comparative purposes in other waterbody studies. During the first two years of the program, samples were collected quarterly from 20 stations in 16 lakes, mostly in Citrus and Highlands counties, and from 6 springs in the northern part of the District (Table 1).

The first report for the Ambient Monitoring Program was published in July 1994, and presented the data for the first two years of sample collection (SWFWMD 1994). Based upon the first two years of data collection, it was concluded that the program should be expanded. Focusing upon only 16 lakes neglected the over 1500 lakes identified in the District's Directory of Lakes report (Gant 1995). Therefore, beginning in 1994, an expanded monitoring program was initiated, incorporating 323 lakes throughout the water management district. The objectives of the program are the same as those previously stated, however, program lakes were sampled twice in a year on a rotating three year schedule; much less frequently than the quarterly schedule used during the first two years of the program. Consequently, detecting trends under the new sampling scheme is unlikely, though identifying lakes that vary from a regional expectation of 'typical' water quality is a valuable trade-off.

Another recent development is also better served by the revised sampling scheme. The Florida Department of Environmental Protection has been directed by the U.S. Environmental Protection Agency, under the authority of Section 303(d) of the Clean Water Act, to develop total maximum daily loads (TMDLs) for various pollutants in water bodies that do not meet the State of Florida water quality standards. Initially states must submit to the USEPA a list, known generally as the "303(d) List", of water bodies that fail to meet state water quality standards, and provide a schedule for the development and implementation of TMDLs for each listed water body. The TMDL process identifies the sources and causes of pollution or stress, including point and non-point sources, and establishes allocations for each source of pollution as needed to attain water quality standards. A closely related effort is the statutory provision for the development of pollutant load reduction goals (PLRGs) for impaired water bodies (Section 60-40.210(18)).

PLRGs are specific numeric targets for load reduction of pollutants, typically nutrients, that are often linked to ambient water quality goals necessary for sustaining aquatic life. However, unlike TMDLs, there is no formal regulatory process to ensure that water quality targets and PLRGs will be achieved. For both the TMDL and PLRG development efforts, water chemistry data are needed to identify impaired water bodies and to provide baseline water chemistry information about water bodies. The data collected for the ambient monitoring program may be helpful for identifying impaired lakes, and to provide baseline data for many lakes that have no historical, or no recent water chemistry data.

Site Selection

Three groups of approximately 110 lakes each were selected, for a total of 323 lakes. The sampled lakes were selected without regard for their 'expected' water chemistry. A major selection consideration was whether lakes could be accessed. Often access was gained simply by asking lake residents for permission to launch a canoe from their property. Except for some lakes entirely owned by an individual, most lakes could be accessed in this way. Lakes were also selected that had not been recently sampled, although many lakes, particularly in Polk County (Medani and King 1998), were part of a regular monitoring effort by the county. Polk County lakes, however, are sampled at mid-depth, and the County's laboratory analyzes for fewer parameters. Similarly, Hillsborough County's Lake Monitoring Program (LaMP) monitors many lakes in Hillsborough County, but generally analyze samples only for nutrients and chlorophyll *a* (Hillsborough County 1999). Lakewatch, a state-funded volunteer lake monitoring program coordinated and administered by the University of Florida, has become active in many areas of the SWFWMD, including the Highlands County lakes region and the Lake Tsala Apopka region in Citrus County. Lakes in the Lakewatch program are sampled monthly for nutrients, chlorophyll *a*, and Secchi disk transparency, and infrequently for ions, pH, alkalinity, and other common water chemistry constituents (University of Florida 1998).

The 323 sampled lakes and their locations are listed in tabular form in Appendix A. Overall, the sampled lakes represent 21 percent of the total number of lakes, and 55 percent of the total lake surface area of lakes in the District (Table 2(a)) (SWFWMD 1995). Many of the lakes in the directory of District lakes are quite small, including wet weather ponds and prairie lakes that may have open water only in wet years or only seasonally; many of these lakes are unnamed. If only the named lakes are considered, then the sampled lakes represent 39 percent of the total number of lakes, and 62 percent of the total lake surface area of lakes in the District (Table 2(b)) (SWFWMD 1995). As is evident from tables 2(a) and 2(b), some counties in the District are better represented among the lakes sampled. For example, nearly all of the lakes in Highlands County were sampled (77 lakes sampled of 78 total), because many had never been sampled, or had not been recently sampled. On the other hand, only 1 of a total of 21 lakes in Levy county was sampled. Within the District bounds of Levy County, most lakes are small, and many of the named lakes are wet-weather ponds and shallow wet prairies.

Sampling Methods

For each lake in a sample group, water samples were collected twice in a one-year period. Samples were collected during the cool dry season months of January and February, and during the wet season months of July and August, at one open-water (>50 m from the shoreline or littoral vegetation) station on each lake. Grab samples were collected at the surface (<0.5 m) at each station. Samples for the analysis of total nitrogen, total Kjeldahl nitrogen, ammonia, nitrate-nitrite, orthophosphorus, and total phosphorus were collected in 500 ml polyethylene bottles and preserved with the addition of sufficient concentrated sulfuric acid to lower the sample pH below 2.0. Samples for the analysis of metals were collected in 250 ml bottles and preserved with the addition of sufficient nitric acid to lower the sample pH below 2.0. Samples for the analysis of chlorophyll *a* were collected in opaque, brown polyethylene 1 liter bottles. Samples for the analysis of total suspended solids, turbidity, chloride, alkalinity, and hardness were collected in 1 liter polyethylene bottles. All samples were placed on ice in coolers for transport to the SWFWMD Environmental Laboratory for analysis. Water samples were analyzed using accepted methods of analysis (Table 3) (SWFWMD 1998). Field parameters including temperature, pH, dissolved oxygen, specific conductance, and transparency (Secchi depth) were measured at each station using a Hydrolab Corporation multi-meter and a Secchi disc. Measurements were made at the surface (0.5 meter depth), at mid-depth, and at the bottom at the sample site.

Data Analysis

For data analyses, values below the detectable limits of the analytical method were used as reported by the laboratory. Detection limits are listed in Table 3, and on the data summary sheets for each lake. For the historical water chemistry comparisons, data were obtained from the U.S. Environmental Protection Agency STORET database. In most cases, the data available were insufficient to demonstrate any conclusive trends in water chemistry for the sample lakes, but were useful for demonstrating the degree of variability in the measured constituents over the period of record. Care should be used in evaluating the STORET data, because the reported values are often from multiple agencies, using different methods of sample collection, preparation and analysis. Furthermore, the purpose for sampling is not usually evident in the STORET data; whether the sample was collected to help determine the cause of a fish kill, or to sample an algal bloom, for example, would affect the representativeness of the sample result. The data could therefore be misleading.

Florida Trophic State Index (FTSI) was calculated for each lake, using the equations of Huber *et al.* (1982). The FTSI was devised to integrate different but related measures of lake productivity or potential productivity, into a single number that ranges from 0 to 100. The measures included in the calculation are transparency (Secchi depth), chlorophyll *a*, total nitrogen and total phosphorus. There are factors which can cause an over- or underestimation of trophic state, such as lakes that are highly colored, and lakes with large volumes of aquatic plants. However, the FTSI is generally useful for comparing the productivity or the potential

productivity of lakes. Trophic state determinations used in the individual lake data summaries were based upon FTSI, and from the criteria of Forsberg and Ryding (1980). Some interpretation of the data was necessary, and when the criteria applied to the data were conflicting, greatest weight was placed upon chlorophyll *a* concentrations, and then on limiting nutrient concentrations, and then on Florida TSI.

Data Summary

Median lake concentrations and measures for most parameters spanned a considerable range (Table 4). Lake surface area ranged from 3 acres (Unnamed Lake, Pasco County) to 4693 acres (Crooked Lake, Polk County). Lake pH ranged from a low of 4.44 in Lake Ruth, Highlands County to 10.04 in Lake Hancock in Polk County. Specific conductance was very low (25 uS/cm) in Lake Marion, Levy County, and ranged to over 7300 uS/cm in Lake Maggiore in Pinellas County. Transparency ranged from 8.1 m in Lake Isis, Highlands Co., to 0.2 m in Lake Effie in Polk Co. Chlorophyll *a* ranged from a median of 1.0 ug/l in several lakes (Table 4) to 147 ug/l in Lake Effie, Polk County. Median Florida trophic state index (FTSI) was least in Buck Lake, Highlands County (10 FTSI units) and greatest in Lake Effie (89 FTSI units).

Other measures and concentrations typically spanned one or more orders of magnitude, including total nitrogen (range 0.31 to 10.5 mg/l), total phosphorus (range <0.01 to 0.23 mg/l), and alkalinity (range <1 to 217 mg/l as CaCO₃) (Table 4). Ion concentrations also varied greatly, for example, calcium (range 1 to 116 mg/l), sodium (range 1.1 to 872 mg/l), and sulfate (range <0.05 to 98 mg/l) (Table 4). Distributions of the median lake concentrations for the sample lake data set were not normally distributed (Shapiro-Wilks statistic (W), $p < 0.05$, Table 4). With the exception of pH (Appendix B, plot p), plots of the variable distributions demonstrated positive skewness, *i.e.*, a greater proportion of the sampled lakes had concentrations or measures in the lower end of their respective ranges (Appendix B, plots a-y). Because of their departure from normality, nonparametric statistical methods of analysis were used for describing the data and relationships in this report.

Table 5 shows the distribution of nuisance vegetation within the sampled lakes. The nuisance species considered were the non-native species waterhyacinth (*Eichornia crassipes*), Hydrilla (*Hydrilla verticillata*), and Melaleuca (*Melaleuca quinquenervia*). Field personnel noted the presence of these non-native nuisance species whenever a sample lake was visited. A native specie, Cattails (*Typha spp.*) may spread to nuisance proportions, interfering with lake access, or dominating the shoreline to such an extent that it excludes a diversity of littoral vegetation. For this report, the threshold for 'nuisance' status for cattails was 30 percent shoreline coverage; that is, if 30 percent or more of the shoreline length was estimated to be dominated by cattails.

Percentile Distributions of Water Chemistry for the Sampled Lakes

To aid the characterization of water chemistry for individual lakes, and to describe the water chemistry of lakes District-wide, cumulative percentile distributions were calculated and plotted for the sampled lakes (Figures 1 through 12). The lake distribution plots show both the calculated sample lake distribution, as well as the distributions for Florida lakes as presented by Friedemann and Hand (1989). The distributions for Florida lakes were calculated from observations for Florida lakes reported in the U.S. Environmental Protection Agency STORET data base, for lakes sampled from the early 1970s through 1986 (Friedemann and Hand 1989). In most of the distribution plots (Figures 1 through 12), it is clear that lakes in the SWFWMD diverge considerably from the state distributions for many water chemistry measures. This could be due to several factors:

- 1) Water chemistry of lakes in the District may be different from the state in general, due to regional differences in land use, soils, hydrology, and underlying geology.
- 2) The state distribution may be biased toward lakes that have higher concentrations of nutrients and other water chemistry constituents. As mentioned previously, for observations in STORET it is difficult to know why water chemistry samples were collected. Were a greater proportion of lakes the object of study because they were impaired in some way, or because they received effluent from an industrial or municipal discharge? Were a disproportionate number of samples collected to investigate the potential causes of fish kills, or for some other observed change in lake biology? Are lakes more frequently sampled because they have good water quality, or poor water quality? Without a randomized sampling design, it is difficult to determine how representative the sample is of the total population of lakes.
- 3) A greater number of lakes in the 1970s and through the 1980s received direct discharges from industrial and municipal wastewater sources, or were downstream from lakes or streams that received discharges. These point sources have since been cleaned up and the discharges have been redirected to spray fields, or reuse systems. These sources would be reflected in the Friedemann and Hand (1989) state distributions, but not in the District's more recent data set. This difference between the two data sets would likely account for some of the divergence of the two distributions, particularly in the upper percentile ranges.
- 4) As alluded to previously, the 323 lakes in the District's Ambient Monitoring Program are not evenly distributed across the District. For example, nearly all of the Highlands County lakes were sampled, but only 35 percent of Hillsborough County lakes were sampled. To test if this influenced the overall distribution, lakes in the 323-lake data set were randomly selected in those counties that were over-represented, to create a smaller data set that better approximated the actual distribution of lakes in the District. Multiple distribution functions created by this method did not vary greatly from the distribution for

all 323 lakes in the larger data set. All 323 lakes were used to calculate the distributions shown in Figures 1 to 12.

The Florida DEP is implementing a randomized sampling scheme across the state, known as the Integrated Water Resource Monitoring plan (IWRM), for water bodies of the state. Distributions of water chemistry variables from the results of this monitoring plan should more accurately represent the population of Florida lakes. A randomized sampling scheme is also being considered for the District's ambient monitoring program, so that the distributions of water chemistry variables can be used with greater confidence that they are representative of the population of lakes. However, the greatest problem with such a plan is gaining access to many lakes, particularly smaller lakes, that are situated on private lands, or that have no roads to them. The additional time and effort needed to gain permission and to otherwise seek access to these lakes may make such a plan unfeasible.

Even with these limitations and caveats, it is interesting to compare the two distributions. Concentrations of chlorophyll *a* in the SWFWMD are generally lower than for the state as a whole (Figure 2). The median, or 50th percentile, at 6.2 ug/l is about one-third the state median of 19 ug/l. This relationship remains true for most of the rest of the distribution, though they begin to converge after the 80th percentile. The distributions for specific conductance are similar to the 50th percentile, but diverge thereafter (Figure 4). At the 95th percentile, specific conductance in Florida lakes is more than two times greater than for District lakes. To some extent, it seems probable that if lakes are selected from a broader range of physiography, geology and soils, that they would display greater divergence at the extremes of their distributions (*i.e.*, Florida lakes are representative of all of the diversity of soils, physiography, and geology that exist in Florida; lakes in the Southwest Florida Water Management District represent only a subset of this diversity).

The District distributions for total nitrogen (Figure 8) and pH (Figure 6) are very similar to those for all Florida lakes. The distribution of total phosphorus concentrations in District lakes diverged greatly from the state distribution (Figure 10). The District lake distribution for total P concentration was less than half the concentration of the state distribution at the 50th percentile. Note that for District lakes, 31 percent of the lakes had concentrations of total phosphorus below the laboratory detection limit of 0.01 mg/l (Figure 10). At the 90th percentile, total phosphorus concentrations for lakes in the state are more than 3 times greater than for District lakes, and at the 95th percentile the difference in concentrations is 7 fold. Other water chemistry distributions demonstrated similar divergences from the state distributions, including total hardness (Figure 5), Secchi transparency (Figure 7), total alkalinity (Figure 9), total suspended solids (Figure 11), and turbidity (Figure 12).

Ionic Compositions of the Sample Lakes

The ions, primarily chloride, sulfate, bicarbonate, sodium, potassium, calcium, and magnesium in fresh waters, are dissolved from the rock and soil minerals in contact with the lake or inflowing waters. Some ions may also be carried in the air and be deposited by rainfall as, for example, in coastal areas where sodium and chloride and other salts in salt sprays can be carried inland and affect the chemical composition of lakes (Hutchinson 1957). In agricultural regions where the source irrigation water differs from surface waters in their ionic compositions, lake ionic composition may change over time to reflect the relative amount of irrigation water entering the lake through groundwater or surface water runoff. Where ground water differs significantly in chemistry from surface waters, lake water chemistry can change markedly depending upon the relative ratios of ground water to surface water runoff, as has been noted for the Lake Tsala Apopka region (Wolfe 1990). A more extreme example of a lake strongly influenced by aquifer well water is Round Lake in Hillsborough County. Round Lake is augmented with water from the Floridan aquifer to maintain lake levels. It is among the sampled lakes with the greatest total alkalinities (110 mg/L as CaCO₃, Figure 9), and its ionic composition is dominated by calcium bicarbonate. This is in contrast to all of the surrounding lakes, which are predominantly calcium sulfate, calcium chloride, and sodium chloride lakes.

In the Southwest Florida Water Management District, lakes are predominantly of four ionic types: calcium chloride, sodium chloride, calcium sulfate, and calcium bicarbonate (Table 6, Figure 13). As is common in natural waters originating from sedimentary source material and igneous rock (quartzite beach sand) (Hutchinson 1957), the most prevalent cation in the sampled lakes was calcium (215 lakes), followed by sodium (101 lakes). In only four lakes was magnesium the dominant cation, and potassium was not the dominant cation in any of the lakes. The dominant anion was typically chloride (166 lakes), followed by sulfate (92 lakes), and bicarbonate (62 lakes). Carbonate, present in measurable amounts only at pHs greater than 8.3 (Wetzel 1983), was present in 27 of the 323 lakes sampled; it was present in 49 of 1,237 (4 percent) of the total samples collected. Carbonate was not a dominant anion in any of the lakes.

The prevalent chemical type of water in the 323 sample lakes is visually depicted in Figure 13. The lone point in the sodium bicarbonate quadrant is Lake Effie in Polk County, a lake that has historically received effluent from a citrus processing plant, possibly changing the ionic balance of that lake. Calcium bicarbonate lakes, depicted in the left quadrant of the plot, are almost all in the northern regions of the District, including Citrus, Hernando, Sumter and Marion counties. All of the lakes in the Lake Tsala Apopka region are of the calcium carbonate type (Table 7 (a) and (d)). The Floridan aquifer is very close to the surface in this region, and the Withlacoochee River is in direct contact with limestone in some of its reaches; this may explain the predominance of calcium bicarbonate in the Tsala Apopka lakes as well as other lakes in the region. Lake Tsala Apopka lies in the Tsala Apopka Lake Region, described as an erosional valley with thin surficial sands over (Eocene-age) Ocala Limestone. Limestone is at the surface in the eastern portion of the region, and the Withlacoochee River is in contact with the limestone in areas of the Tsala Apopka Lake region (Griffith et al. 1997). The Lake Tsala Apopka region,

however, is a recharge area for the Floridan Aquifer (Wolfe 1990). Too few lakes were sampled in some regions to conclude any regional trends; 3 of five lakes sampled in the Lakeland/Bone Valley Upland were also of the calcium bicarbonate type (Table 7 (a) and (d)).

Chloride was the dominant anion in the greatest number of Florida lake regions (Griffith *et al.* 1997). Chloride was the dominant anion in over 60 percent of the lakes in the lake regions surrounding Tampa Bay (Table 7 (b)), including the Pinellas Peninsula (62% of sampled lakes), Hillsborough Valley (88%) Southwestern Flatlands (81%), Land o' Lakes (75%), Tampa Plain (75%), and Keystone Lakes (74% of sampled lakes). By contrast sulfate was dominant only in the Northern and the Southern Lake Wales Ridges (54 and 77 percent of sampled lakes, Table 7 (c)). Of the cations, calcium was dominant in nearly all regions (Table 7 (d)). Exceptions were the sodium dominated lakes of the Keystone Lakes region (58 percent), the Lake Wales Ridge Transition region (61 percent), and the Southwestern Flatlands (63 percent) (Table 7 (e)).

The concentration of major ions was closely correlated to specific conductance in the sample lakes (Spearman's rank correlation coefficient = 0.96, $P < 0.05$). There were significant differences in ion concentrations in the sampled lakes, between lakes of different ionic types (Mann-Whitney test, $P < 0.05$; Figure 14). Of the five major ionic groups tested, the calcium sulfate lakes had significantly greater specific conductances (Tukey's studentized range test performed on the ranked median conductances for sampled lakes, $P < 0.05$, $n = 309$; Figure 14). There were also significant differences in lake pH between lakes of different ionic types (Mann-Whitney test, $P < 0.05$; Figure 15). The group of lakes characterized as sodium chloride and sodium sulfate lakes tended to have lower pHs than calcium chloride, calcium bicarbonate, and calcium sulfate lakes (Tukey's studentized range test performed on the ranked median specific conductances of sampled lakes, $P < 0.05$, $n = 309$; Figure 15).

Water Chemistry and Soils

Data to describe individual lake watersheds and to compare lake water chemistry with watershed characteristics were generated using GIS (Arc/Info). Lacking lake-specific drainage basin maps or coverages for each lake, it was assumed that the area immediately surrounding a lake was likely representative of land use and soils within the drainage basin. Using the GIS, a 500 meter buffer was constructed around each lake. Within the buffer area, data were extracted from the GIS data base for soil types and 1990 land use. These data were summarized in the working data base as both total surface area and as percentages of each land use and soil type combination of the total 500-meter buffer area.

Data for the chemical characterization of regional soils were compiled from soils chemistry characterization data reports (Carlisle *et al.* 1988, Carlisle *et al.* 1985, Carlisle *et al.* 1981, Carlisle *et al.* 1978, Calhoun *et al.* 1974). Data were plotted for individual soil types, however, few of the samples were tested for total nitrogen content, or for total phosphorus content - the soil components that would be of greatest interest from the standpoint of lake water chemistry. Furthermore, the laboratory methods for determination of phosphorus and nitrogen

varied among samples, making comparison difficult. It was also clear in working with the data that there was a large range in chemical values for a single soil series. Based upon these observations, soil order was chosen as the level of soil taxonomy to use for an investigation of the affect soils might have on water chemistry (see Appendix C for soil series vs. lake water chemistry correlations and plots).

There are ten soil orders (Table 8), however, only seven of the orders were observed within the vicinity of the 323 lakes in this study. The most common soil orders observed (Table 9) were Entisols (58 percent of total buffer area) and Spodosols (23 percent of total buffer area), followed distantly by Ultisols (8 percent) and Histosols (6 percent). Soil fertility is not listed as a principal diagnostic property of soil orders (Table 8); fertility is more typically a reflection of the soil parent material, as well as land cover and land use. However, bar plots are shown in figures 16 through 18, depicting the range of values for selected variables of Florida soils by soil order.

It was hypothesized that lakes with higher concentrations of major ions would be associated with soils of greater sums of total bases, and with greater cation exchange capacity. Briefly, the sum of total bases is the sum of the major cations (Ca, Mg, Na, and K) in a soil extract; cation exchange capacity is a measure of the ability of the soil to attract and retain ions, and is dependent upon soil clay content, type of clay, and amount of soil organic material. Another hypothesis was that lake total phosphorus concentrations would be greater for lakes situated in soil groups with higher soil concentrations of total phosphorus. Another potential soil/water chemistry relationship is that between lake water chemistry and soil hydraulic conductivity. Hydraulic conductivity is a measure of the ability of a soil to transmit water (Carlisle and Brown 1982). High hydraulic conductivity could affect water chemistry in at least two ways: by more rapidly transporting substances through the soil to the surface water body, and by more effectively and rapidly leaching dissolved mineral substances from the soil, leaving the soil relatively deplete of minerals. Finally, it was hypothesized that lake pH would demonstrate a positive relationship to soil pH.

Spearman rank correlation coefficients for water chemistry parameters with soil order were calculated, and are shown in Table 10; those relationships with the strongest correlation were plotted (Figures 19 through 21) to depict the suggested relationships. For the working data set, if a soil order percent of total buffer area was equal to zero, then the observation was set to 'missing', so that only lakes that had some area of soils of a given soil order were used for calculations and plotting. Raw data were plotted to see the true relationship, but the Spearman rank coefficient is calculated from the rank transformed variables, so ranks were also plotted.

In general, the relationships between water chemistry with soils were weak (Table 10). As revealed in the plots of both raw and rank-transformed data, most of the relationships are visually tenuous. Potassium concentrations appeared to be lower in lakes in basins with greater areas of soils in the Alfisol soil order (Figure 19). However, as for all of these correlations and plots in which soil coverage is expressed as a percentage, the remaining percentage is composed of another or perhaps several different soil order types. These other soils may have greater

influence on water chemistry than the soil for which the correlation is significant. As an example of this effect, as the percent area of Alfisols increase, the percent area of other soils decrease, including soils most commonly used for citrus groves, Entisols. Lake concentrations of potassium and other ions tend to increase in citrus growing regions of the District (see the section on land use/cover and water chemistry). Therefore, the negative relationship of potassium with Alfisols may be due to the inverse, positive relationship of potassium with Entisols. The plots demonstrate the considerable variation in values for potassium across the range of Alfisols percent area coverage.

Lake sodium concentrations tend to be lower with increased dominance of Entisols in the watershed, which is visually more apparent in the plot of the raw data (Figure 20). Entisols are frequently composed of bare sands, with little organic matter or clays, and with little or no retentive capabilities for ions. They also rapidly transmit water through their depth. These two factors may have the effect of depleting the soil of ions, particularly those ions that are not replaced by fertilizers or other sources.

Lake color was found to increase as Histosols were more represented in the watershed (Figure 21). Histosols are organic soils, consisting mostly of decomposed and partially decomposed plant materials. They are associated with wetlands and other aquatic resources. Tannins and other color-producing chemicals are released from the decomposing organic material, causing the brown to yellow tint common in many Florida waters associated with marshes and swamps.

Water Chemistry and Land Use

The basis for many, if not all, watershed nutrient loading models is the assumption that the non-point source loading of nutrients from storm water runoff is most influenced by land use. The two factors of land use having the greatest effect upon runoff water quality are the volume of runoff, as affected by proportion of watershed impervious to pervious area, and the concentrations of nutrients and other pollutants dissolved or entrained in the runoff water. Runoff coefficients are assigned in the model by assuming “typical” impervious area and runoff pollutant concentration for each land use considered in the model. Some loading models use hydrologic soil groups as the basis for calculations of runoff from land use on specific soils. Hydrologic soil groups (A, B, C, D, and B/D) are assigned by the United States Natural Resource Conservation Service based upon the physical properties of the soils and their geographical settings. Soil group 'A' has the least potential for runoff, whereas soil group 'D' has the greatest.

As discussed previously, a 500 meter buffer was constructed around each lake using the GIS (Arc/Info). Land use data (1990) were extracted from the GIS data base for lands within a 500 meter buffer around each lake. These data were summarized in the working data base as both total surface area and as percentages of each land use within the total 500-meter buffer area. For a general overview of the effect land use might have on lake water chemistry in the study

lakes, the land use was further summarized to level 1 DOT land use categories (*i.e.*, urban, agriculture, range, upland forest, and water/wetlands).

Table 12 displays the Spearman rank correlation coefficients for the 10 measures of water chemistry with the greatest correlations with each of the major land use categories. As for soils, most relationships were weak; the greatest Spearman correlations are generally less than 0.30 for most of the land uses. The exception is citrus groves, which were considered separately from agriculture because of the strength of the relationship between grove land use and many of the water chemistry variables. Plots are shown of land uses displaying the greatest influence on water chemistry. Grove land use, which consists exclusively of citrus groves, has significant ($p < 0.05$) and relatively strong Spearman rank correlations with magnesium ($S = 0.68$, Figure 22), potassium ($S = 0.62$, Figure 22), sulfate ($S = 0.61$, Figure 23), hardness ($S = 0.53$, Figure 23), conductance ($S = 0.52$, Figure 24), and nitrate ($S = 0.52$, Figure 24). The causes of the effect of groves on these measures of water chemistry may be from the irrigation of groves with well water, which would potentially affect sulfate, hardness, conductance, and perhaps magnesium; and from the application of fertilizers to the groves, which would increase concentrations of nitrate and potassium. Both irrigation and fertilization in citrus groves may increase surficial groundwater concentrations of ions, which would be reflected in lake water chemistry of those lakes in which groundwater exchange is significant. Figure 25 is a bubble plot depicting the relationship between grove land use and Entisol soil order on lake nitrate concentrations. Lake nitrate concentrations are greatest when grove land use exceeds 30 percent of the total land area; particularly when the groves occur on Entisols. Entisols may play some role in the higher concentrations observed because, primarily, they are well-drained and so are the preferred soils for citrus production. However, Entisols are well-drained because they are sandy and have high hydraulic conductivities (Figure 18). High hydraulic conductivities promote the rapid movement of water through the soil, which carries with it the highly soluble nitrate into the surficial groundwater, and hence to the lake.

Water Chemistry and Florida Lake Region

A classification scheme was recently developed for Florida lakes by Griffith *et al.* (1997). Briefly, the state was divided into 47 lake regions based on features that influence lake characteristics, including physiography, soils, geology, natural vegetation, and land cover, as well as lake chemistry and lake physical data (Griffith *et al.* 1997). Within the SWFWMD, there are 25 lake regions represented, however, the greatest number of named lakes fall within 14 lake regions (Figure 26). To find how water chemistry in District lakes vary by lake regions, lake region was determined for each sampled lake from a GIS coverage for the state (Griffith *et al.* 1997). Only regions represented by five or more lakes were included in the investigation. For each variable, the median value of all samples collected from a lake was used to characterize the lake.

There were significant differences at $\alpha = 0.05$ between lake regions for all variables tested, with the exception of total nitrogen (Kruskal-Wallis test statistic). Tukey's studentized range test

was used on the rank value of the variables, using $\alpha=0.05$. Results of the Tukey's SRT are displayed on the plots of lake water chemistry by Florida lake region (Figures 27 to 32), and in Table 13. Lake regions in Table 13 were sorted from regions having more distinguishing characteristics, to those with fewer distinguishing characteristics. Lakes in those regions with fewer distinguishing characteristics generally demonstrate greater variability in their water chemistries, and so are more difficult to characterize based solely on water chemistry.

Based on the data collected for the District's lake monitoring program, lakes in the **Lakeland/Bone Valley Upland** and the **Southwestern Flatlands** lake regions are among the most productive, with high concentrations of total phosphorus (Figure 28) and chlorophyll *a* (Figure 30), low transparency (Secchi Depth, Figure 32), and correspondingly high Florida trophic state index (FTSI, Figure 30). Lakes in these regions also can be characterized as having high turbidity and total suspended solids (Figure 27), and high pH (Figure 29, Table 13); the latter are also probably a reflection of the high level of productivity. By contrast, lakes in the **Southern Lake Wales Ridge** and **Keystone Lakes** regions can be characterized as having low concentrations of total phosphorus (Figure 28), chlorophyll *a* (Figure 30), and Florida TSI (Figure 30), and relatively high transparency (Figure 32). Lakes of the Southern Lake Wales Ridge also have among the highest concentrations of nitrate and sulfate (Figure 31). Lakes of the **Tsala Apopka** lake region as a group have low turbidity and total suspended solids (Figure 27), low conductivity (Figure 32), and high total alkalinity (Figure 29). They also have low concentrations of sulfate and nitrate-nitrite (Figure 31).

Lakes of the **Winter Haven/Lake Henry Ridges** region can be characterized by these data as having high turbidity (Figure 27), high conductivity (Figure 32), and high total alkalinity and high pH (Figure 29). **Pinellas Peninsula** lakes generally have high concentrations of total phosphorus (Figure 28), high conductivity (Figure 32), as well as high total alkalinity and pH (Figure 29). Lakes of the **Northern Lake Wales Ridge** can be characterized as high transparency lakes, with correspondingly low turbidity. Similar to lakes of the Southern Lake Wales Ridge, **Northern Lake Wales Ridge** lakes as a group have high concentrations of nitrate and sulfate. Lakes in the **Southern Brooksville Ridge**, **Weeki Wachee Hills**, and **Hillsborough Valley** are notable for their low conductivities. In addition, lakes in the **Southern Brooksville Ridge** region have low nitrate and sulfate, lakes in the **Weeki Wachee Hills** region have low chlorophyll *a* concentrations and correspondingly low Florida TSI, and lakes in the **Hillsborough Valley** have high total phosphorus and low transparency. **Tampa Plain** lakes can generally be characterized as having low pH. Lakes in the Land o' Lakes region displayed generally moderate concentrations and measures, and were most notable for their lack of strong differences that might distinguish them from lakes in the other regions, at least for the water chemistry variables considered for this investigation.

As is evident from the bar plots of water chemistry in the different lake regions, water chemistry can vary greatly within lakes of any given region. In fact, the variation is greater because the bars depict only the interquartile range (25th to the 75th percentile), or a total of 50 percent of lakes. The remaining 50 percent of the lakes not shown have concentrations that are

greater or less than the range shown. In conclusion, the Florida Lake Regions classification scheme is a useful tool for describing groups of lakes in context with their physiographic, geologic, and hydrologic setting. However, as shown in the plots the chemistry of lakes in a given lake region typically display a wide range of values for most constituents, and drawing conclusions or generalities about water chemistry in any one lake, based on its inclusion in a particular lake region is not practical. There appear to be other, more localized factors that determine a particular lake's water chemistry. On the other hand, it is why lakes vary within lake regions that may be of interest to lake managers.

Table 1. Locations of the original (1992-1995) Ambient Monitoring Program water bodies and stations.

Waterbody	County	Latitude	Longitude
Lake Tsala Apopka - Floral City Pool	Citrus	284520	821702
Lake Tsala Apopka - Hernando Pool	Citrus	285225	822203
Lake Tsala Apopka - Inverness Pool	Citrus	285021	821901
Lake Maggiore	Pinellas	274414	823914
Lake Francis	Highlands	272023	812422
Lake Josephine	Highlands	272349	812541
Lake Tulane	Highlands	273509	813015
Lake Persimmon	Highlands	272117	812422
Lake Wolf	Highlands	272519	812825
Lake Verona	Highlands	273551	812950
Lake Lotela	Highlands	273438	812855
Lake Viola	Highlands	273646	812941
Little Lake Jackson	Highlands	272808	812750
Lake Jackson - North Station	Highlands	273027	812839
Lake Jackson - Central Station	Highlands	272954	812738
Lake Jackson - South Station	Highlands	272848	812754
Lake June in Winter - North Station	Highlands	271846	812206
Lake June in Winter - South Station	Highlands	271757	812412
Lake Placid - North Station	Highlands	271555	812125
Lake Placid - South Station	Highlands	271345	812145
Rainbow Springs	Marion	290609	822616
Crystal River Spring - Tarpon Hole Spring	Citrus	285254	823540
Crystal River Spring - Idiots Delight Spring	Citrus	285316	823527
Crystal River Spring - Catfish Corner Spring	Citrus	285353	823556
Homosassa Springs	Citrus	284757	823519
Chassahowitzka Springs	Citrus	284255	823436

Table 2(a). Distribution of sampled lakes by county, for all lakes in the SWFWMD (source: R. D. Gant, January 1994, "Directory of Lakes within the Southwest Florida Water Management District", SWFWMD, Brooksville).

<u>County</u>	<u>Total Surface Area</u>	<u>Number of Lakes</u>	<u>Total Surface Area Sampled</u>	<u>Number of Lakes Sampled</u>	<u>Pct of Total Lake Number Sampled</u>	<u>Pct of Total Lake Surface Area Sampled</u>
Polk	56,969	390	39,660	73	19	70
Highlands	20,849	78	20,248	77	99	97
Sumter	13,684	195	1959	4	2	14
Pasco	11,303	273	4271	40	15	38
Hillsborough	8290	201	3426	70	35	41
Hernando	5427	122	1512	17	14	28
Citrus	4727	45	3144	22	49	67
Pinellas	4477	30	814	14	47	18
Levy	4272	21	74	1	5	2
Marion	2160	48	468	5	10	22
Charlotte	1784	87	-	-	-	-
Sarasota	1586	15	-	-	-	-
Manatee	1133	17	-	-	-	-
Desoto	807	39	-	-	-	-
Lake	196	7	-	-	-	-
Hardee	174	2	-	-	-	-
Total	137,838	1570	75,576	323	21	55

Table 2(b). Distribution of sampled lakes by county, for all named lakes in the SWFWMD (Gant 1994). Many lakes in the District, particularly smaller lakes and lakes that are marsh areas with seasonal open water, are unnamed and were not included in the calculations for this table.

<u>County</u>	<u>Total Surface Area</u>	<u>Number of Lakes</u>	<u>Total Surface Area Sampled</u>	<u>Number of Lakes Sampled</u>	<u>Pct of Total Lake Number Sampled</u>	<u>Pct of Total Lake Surface Area Sampled</u>
Polk	54,648	253	39,660	73	29	73
Highlands	20,777	75	20,219	74	99	97
Sumter	9489	49	1959	4	8	21
Pasco	7953	132	4222	38	29	53
Hillsborough	7319	136	3426	70	51	47
Hernando	4472	77	1508	16	21	34
Citrus	4302	32	3144	22	69	73
Pinellas	4270	19	814	14	74	19
Levy	4069	11	74	1	9	2
Marion	1335	18	468	5	28	35
Sarasota	1406	3	-	-	-	-
Manatee	968	3	-	-	-	-
Desoto	244	6	-	-	-	-
Charlotte	207	4	-	-	-	-
Hardee	162	1	-	-	-	-
Lake	56	3	-	-	-	-
Total	121,677	822	75,494	317	39	62

Table 3. Water chemistry parameters, units, detection limits, and all analytical methods used. If more than one method is indicated for a parameter, the methods are listed in the order that they were most frequently used. When not directly determined by one analytical procedure, total nitrogen was calculated from the sum of total Kjeldahl nitrogen and nitrate+nitrite; total alkalinity was determined from the sum of bicarbonate alkalinity, carbonate alkalinity and hydroxide alkalinity; and nitrate+nitrite was determined from the sum of nitrate and nitrite.

<u>Parameter</u>	<u>Units</u>	<u>Detection Limit</u>	<u>Methods Used</u>
Ammonia	mg/l as N	0.03	Std. Meth. 417G, EPA 350.1, Std. Meth. 4500-NH3
Bicarbonate Alkalinity	mg/l as CaCO ₃	1	EPA 310.1, Std. Meth. 2320 B
Calcium	mg/l	0.04	EPA 300.7, Std. Meth. 3113-B
Carbonate Alkalinity	mg/l as CaCO ₃	1	EPA 310.1, Std. Meth. 2320 B
Chloride	mg/l	0.05	USGS I-2057-85, Std. Meth. 429, EPA 300.0
Chlorophyll <i>a</i> (monochromatic.)	ug/l	1	Std. Meth. 10200 H, 1002G
Chlorophyll (trichromatic)	ug/l	1	Std. Meth. 1002G
Color	PtCo units	5	Std. Meth. 2120 B, 204A
Conductivity	uS/cm at 25C	1	Std. Meth. 2510B
Hardness	mg/l as CaCO ₃	0.02	Std. Meth. 2340 B
Hydrogen Ion	standard units	0.1	EPA 150.1
Hydroxide Alkalinity	mg/l as CaCO ₃	1	EPA 310.1, Std. Meth. 2320 B
Iron	ug/l	0.03	Std. Meth. 303A, EPA 236.1, Std. Meth. 3111-B, 3113-B
Magnesium	mg/l	0.006	EPA 300.7, Std. Meth. 3113-B
Nitrate	mg/l as N	0.01	EPA 353.2, EPA 300.0
Nitrate+Nitrite	mg/l as N	0.01	Std. Meth. 419, EPA 353.2
Nitrite	mg/l as N	0.01	EPA 353.2
Orthophosphorus	mg/l as P	0.01	Std. Meth. 4500-P, 424G
pH (field)	standard units	0.1	Std. Meth. 4500, EPA 150.1
Potassium	mg/l	0.07	EPA 300.7, Std. Meth. 3113-B
Sodium	mg/l	0.06	EPA 300.7, Std. Meth. 3113-B
Sulfate	mg/l	0.05	EPA 300.0
Total Alkalinity	mg/l as CaCO ₃	1	EPA 310.1, Std. Meth. 403
Total Kjeldahl Nitrogen	mg/l as N	0.06	Std. Meth. 420A, EPA 351.1, 351.2
Total Nitrogen	mg/l as N	0.06	ASTM D5176
Total Phosphorus	mg/l as P	0.01	Std. Meth. 424F, EPA 365.1
Total Suspended Solids	mg/l	0.05	Std. Meth. 2540, 209C
Transparency	meters		Secchi disc
Turbidity	NTU	1	Std. Meth. 2130 B

Table 4. Summary of water chemistry for all sample lakes. Individual lake median values were determined for each lake. Units are mg/l, except as noted. Normal is the value of the Shapiro-Wilk Statistic which tests the null hypothesis that the data are from a normally distributed population. Values of W approaching 1 are evidence that the sampled population is normally distributed. Prob(W) is the probability (p) of obtaining the calculated value of W if the sample were from a normally distributed population. In general, the null hypothesis should be rejected (that the sample data were drawn from a normally distributed population) when the p value is less than 0.05 (Hatcher and Stepanski 1994). Plots of the variable distributions are presented in Appendix B.

<i>Parameter</i>	<i>N</i>	<i>Minimum</i>	<i>10th Percentile</i>	<i>Median</i>	<i>90th percentile</i>	<i>Maximum</i>	<i>Normal</i>	<i>Prob(W)</i>
Orthophosphorus	323	<0.01	<0.01	<0.01	0.026	0.2	0.464	<0.001
Ammonia	323	<0.03	<0.03	<0.03	0.11	1.08	0.469	<0.001
Nitrate-nitrite	323	<0.01	<0.01	0.016	0.29	9.6	0.286	<0.001
Total Phosphorus	323	<0.01	<0.01	0.014	0.062	0.23	0.580	<0.001
Total Suspended Solids	323	<0.05	0.40	1.90	9.50	47.2	0.639	<0.001
Potassium	323	<0.07	0.40	3.60	10.0	36.0	0.822	<0.001
Transparency (meters)	298	0.200	0.50	1.50	3.44	8.1	0.854	<0.001
Pheophytin (Fg/l)	323	<1	0.50	2.40	11.6	88.2	0.512	<0.001
Total Kjeldahl Nitrogen	323	0.12	0.52	1.05	2.01	3.41	0.929	<0.001
Turbidity (NTU)	323	<1	<1	1.90	10.6	33.0	0.685	<0.001
Total Nitrogen	323	0.31	0.60	1.19	2.32	10.5	0.692	<0.001
Magnesium	323	0.50	1.30	3.40	11.0	102	0.503	<0.001
Chlorophyll <i>a</i> (Fg/l)	323	1.0	2.0	5.9	37.6	147	0.624	<0.001
Sulfate	321	<0.05	3.00	16.0	43.0	98.0	0.838	<0.001
Total Alkalinity (mg/l as CaCO ₃)	323	<1	4.0	24.0	64.0	217	0.831	<0.001
Calcium	323	1.0	4.4	12.5	28.0	116	0.821	<0.001
Sodium	323	1.1	4.7	8.9	17.5	872	0.120	<0.001
Color (Pt-Co units)	323	<5	<5	18	98	275	0.653	<0.001
pH (SU)	323	4.44	6.28	7.29	8.40	10.04	0.977	0.061
Chloride	323	2.0	8.0	19.0	33.0	1434	0.127	<0.001
Surface Area (a)	323	3	12	71	517	4693	0.401	<0.001
Iron (Fg/l)	323	<0.03	16.0	37.0	160	774	0.584	<0.001
Hardness (mg/l as CaCO ₃)	323	5.0	21.0	48.0	99.0	840	0.549	<0.001
FTSI (TSI units)	323	10.0	23.0	39.0	64.0	89.0	0.947	<0.001
Conductivity (FS/cm at 25C)	323	25.0	86.0	180	309	7320	0.220	<0.001

Table 5. Summary of nuisance aquatic vegetation in 323 lakes in the Southwest Florida Water Management District. For waterhyacinth (*Eichornia crassipes*), Hydrilla (*Hydrilla verticillata*), and Melaleuca (*Melaleuca quinquenervia*), field personnel noted whether the plant was observed in the lake. Field personnel also visually estimated the percentage of shoreline dominated by cattails (*Typha spp.*); represented in this table are lakes with shoreline dominance by cattails estimated to be equal to or greater than 30 percent of the total shoreline length. Frequency and percent are of the 323 lakes sampled.

<i>Nuisance Vegetation</i>	<i>Frequency</i>	<i>Percent</i>
Waterhyacinth (presence)	6	2
Hydrilla (presence)	19	6
Melaleuca (presence)	24	7
Cattails (greater than 30 percent of shoreline dominated)	49	15

Table 6. Dominant Ions in the sampled lakes, determined from concentrations, percent meq/L.

<i>Dominant Ions</i>	<i>Number of Sample Lakes</i>
Calcium Chloride (CaCl ₂)	83
Sodium Chloride (NaCl)	81
Calcium Sulfate (CaSO ₄)	72
Calcium Bicarbonate (Ca(HCO ₃) ₂)	60
Sodium Sulfate (Na ₂ SO ₄)	18
Magnesium Chloride (MgCl)	2
Magnesium Sulfate (MgSO ₄)	2
Sodium Bicarbonate (NaHCO ₃)	2

Table 7. Dominant ions in the sampled lakes, by Florida lake region (Griffith *et al.* 1997), anions: (a) bicarbonate, (b) chloride, (c) sulfate; cations: (d) calcium, and (e) sodium. Percent is percentage of total lakes sampled in the subject lake region, n is the total number of lakes sampled in the subject lake region.

(a) bicarbonate

Florida Lake Region	Percent	N
Gulf Coast Lowlands	100	1
Tsala Apopka	100	20
Webster Dry Plain	100	1
Lakeland/Bone Valley Upland	60.0	3

(c) sulfate

Florida Lake Region	Percent	N
Wimauma Lakes	100	1
Southern Lake Wales Ridge	77.4	41
Northern Lake Wales Ridge	53.8	7

(d) calcium

Florida Lake Region	Percent	N
Gulf Coast Lowlands	100	1
Lakeland Bone Valley Upland	100	5
Northern Brooksville Ridge	100	4
Pinellas Peninsula	100	13
Tsala Apopka	100	20
Webster Dry Plain	100	1
Northern Lake Wales Ridge	84.6	11
Winter Haven/Henry Ridges	81.3	26
Southern Brooksville Ridge	80.8	21
Land o' Lakes	77.3	34
Hillsborough Valley	75.0	6
Weeki Wachee Hills	72.7	8
Southern Lake Wales Ridge	67.9	36
Central Valley	66.7	2
Tampa Plain	62.5	5

(b) chloride

Florida Lake Region	Percent	N
Central Valley	100	3
Northern Brooksville Ridge	100	4
Hillsborough Valley	87.5	7
Southwestern Flatlands	81.3	3
Land o' Lakes	75.0	33
Tampa Plain	75.0	6
Keystone Lakes	74.2	23
Lake Wales Ridge Transition	66.7	24
Pinellas Peninsula	61.5	8
Southern Brooksville Ridge	61.5	16
Weeki Wachee Hills	54.5	6

(e) sodium

Florida Lake Region	Percent	N
Wimauma Lakes	100	1
Southwestern Flatlands	62.5	10
Lake Wales Ridge Transition	61.1	22
Keystone Lakes	58.1	18

Table 8. A description of the soil orders, from Mary E. Collins and Robert E. Caldwell, “Soil Taxonomy – The System of Soil Classification”, in: Carlisle, V.W. and R.B. Brown, 1982, Florida Soil Identification Handbook, University of Florida Soil Science Department, 186 pp. Those orders shown in bold type were found in the vicinity of one or more sample lakes (n=323).

<i>Order Name</i>	<i>Principal Diagnostic Properties</i>
Alfisols	Mineral soils; relatively low in organic matter; relatively high base saturation; an illuvial horizon of silicate clays; moisture available to mature a crop.
Aridosols	Mineral soils; relatively low in organic matter; inadequate moisture to mature a crop without irrigation in most years; some pedogenic horizons
Entisols	Mineral soils; weak or no pedogenic horizons; no deep wide cracks in most years.
Histosols	Organic soils; organic in more than half of upper 80 cm.
Inceptisols	Mineral soils; some pedogenic horizons and some weatherable minerals; moisture available to mature a crop in most years; no horizon of illuvial clays; relatively low in either organic matter or base saturation, or in both.
Mollisols	Mineral soils; thick dark surface horizon; relatively rich in organic matter; high base saturation throughout; no deep wide cracks in most years.
Oxisols	Mineral soils; no weatherable minerals; inactive clays; no illuvial horizon of silicate clays.
Spodosols	Mineral soils; an illuvial horizon of amorphous aluminum and organic matter; with or without amorphous iron.
Ultisols	Mineral soils; an illuvial horizon of silicate clays; low base saturation; moisture available to mature a crop in most years.
Vertisols	Clayey soils; deep wide cracks at some time in most years.

Table 9. Summary of soil orders present in the 500 meter buffer areas around the sample lakes (n=323).

<i>Soil Order</i>	<i>Area (m²)</i>	<i>Area (acres)</i>	<i>Percent of Total Area</i>
Entisols	422,915,837	104,501	57.7
Spodosols	169,075,726	41,778	23.1
Ultisols	58,520,145	14,460	8.0
Histosols	43,984,985	10,869	6.0
Inceptisols	22,509,825	5,562	3.1
Alfisols	10,171,652	2,513	1.4
Mollisols	5,868,686	1,450	0.8
Total	733,046,856	181,133	100.0

Table 10. Summary of soil chemistry data, from soil data for soils within the SWFWMD bounds. (Data source: Carlisle *et al.* 1988, Carlisle *et al.* 1985, Carlisle *et al.* 1981, Carlisle *et al.* 1978, Calhoun *et al.* 1974).

Soil Cation Exchange Capacity

<i>Soil Order</i>	<i>N</i>	<i>Minimum</i>	<i>25th Percentile</i>	<i>Median</i>	<i>75th Percentile</i>	<i>Maximum</i>
Entisols	617	0.30	0.63	1.5	3.2	7.1
Inceptisols	49	0.80	2.52	4.6	10.0	19.4
Ultisols	503	1.12	2.40	4.7	8.0	12.1
Spodosols	1021	0.72	1.98	6.1	12.0	19.7
Alfisols	508	0.81	2.03	7.2	16.6	33.1
Mollisols	121	4.60	14.20	23.0	37.9	53.4
Histosols	150	4.30	16.52	64.7	126.9	178.8

Soil pH

<i>Soil Order</i>	<i>N</i>	<i>Minimum</i>	<i>25th Percentile</i>	<i>Median</i>	<i>75th Percentile</i>	<i>Maximum</i>
Histosols	137	3.50	4.00	4.8	5.9	7.1
Spodosols	1021	4.20	4.60	4.9	5.4	6.2
Ultisols	494	4.50	4.80	5.1	5.5	6.0
Inceptisols	49	4.40	4.90	5.2	5.7	6.2
Entisols	612	4.60	5.00	5.4	5.8	6.4
Alfisols	507	4.60	5.10	5.9	6.8	7.8
Mollisols	120	5.15	5.70	6.6	7.7	8.2

Soil Sum of Bases

<i>Soil Order</i>	<i>N</i>	<i>Minimum</i>	<i>25th Percentile</i>	<i>Median</i>	<i>75th Percentile</i>	<i>Maximum</i>
Entisols	621	0.03	0.07	0.2	0.8	2.4
Spodosols	1020	0.05	0.12	0.4	1.4	4.6
Inceptisols	49	0.09	0.20	0.4	1.3	3.4
Ultisols	503	0.10	0.20	0.7	1.6	3.0
Alfisols	506	0.24	0.75	3.6	10.6	18.6
Histosols	150	0.70	3.90	14.0	36.0	79.0
Mollisols	121	3.20	8.26	18.5	30.4	45.2

Soil Total Phosphorus

<i>Soil Order</i>	<i>N</i>	<i>Minimum</i>	<i>25th Percentile</i>	<i>Median</i>	<i>75th Percentile</i>	<i>Maximum</i>
Spodosols	245	8.00	30.00	60.0	160.0	507.0
Entisols	176	8.00	22.50	60.0	146.5	345.0
Histosols	52	15.00	41.00	67.5	172.0	327.0
Alfisols	164	22.00	40.00	82.0	254.0	1055.0
Inceptisols	8	22.00	52.50	109.0	427.0	913.0
Ultisols	116	52.00	75.00	168.5	528.5	1282.0
Mollisols	44	45.00	56.50	217.0	552.5	1595.0

Soil Organic Carbon

<i>Soil Order</i>	<i>N</i>	<i>Minimum</i>	<i>25th Percentile</i>	<i>Median</i>	<i>75th Percentile</i>	<i>Maximum</i>
Entisols	600	0.00	0.06	0.1	0.4	30.1
Ultisols	494	0.00	0.08	0.1	0.3	2.1
Alfisols	505	0.01	0.09	0.2	0.5	39.6
Inceptisols	49	0.06	0.15	0.4	1.4	7.0
Spodosols	1018	0.01	0.17	0.5	1.3	38.4
Mollisols	121	0.02	0.19	0.6	2.6	40.2
Histosols	150	0.02	0.41	23.2	46.1	59.2

Soil Hydraulic Conductivity

<i>Soil Order</i>	<i>N</i>	<i>Minimum</i>	<i>25th Percentile</i>	<i>Median</i>	<i>75th Percentile</i>	<i>Maximum</i>
Mollisols	95	0.00	0.20	1.1	7.7	407.5
Alfisols	409	0.00	0.60	6.9	20.3	405.0
Ultisols	416	0.00	1.00	9.9	20.6	86.8
Histosols	116	0.00	1.14	13.9	32.2	636.0
Spodosols	932	0.00	5.10	16.4	29.6	139.0
Inceptisols	48	0.30	7.85	18.7	39.6	64.4
Entisols	544	0.00	27.65	44.1	70.2	256.0

Table 11. Spearman rank correlation coefficients (S, Prob>|R| under Ho: Rho=0, number of observations) for soil order with median lake water chemistry variables. Values of soil order percent areal coverage equal to zero were set to missing (i.e., if a soil order percent total buffer area was equal to zero for an individual lake, then the percent coverage of that soil order was set to missing for that lake). K=potassium, SO4=sulfate, MG=magnesium, HARD=total hardness, COND=conductance, TP=total phosphorus, NH4=ammonia, FE=iron, PH=pH, NA=sodium, CL=chloride, NOX=nitrite+nitrate, NO2=nitrite, FTSI=Florida trophic state index, TKN=total Kjeldahl nitrogen, CHLA=chlorophyll a, TURB=turbidity, ORTP=orthophosphorus, PHEO=pheophytin, DO=dissolved oxygen, TSS=total suspended solids, TALK=total alkalinity, CA=calcium, NO3=nitrate.

Alfisols	K	SO4	MG	HARD	COND
	-0.41859	-0.35189	-0.32037	-0.30958	-0.23408
	0.0003	0.0024	0.0061	0.0081	0.0478
	72	72	72	72	72
	TP	NH4	COLOR	FE	PH
	0.22906	0.21371	0.20443	0.20314	-0.19163
0.0529	0.0715	0.0850	0.0870	0.1068	
72	72	72	72	72	
Entisols	NA	CL	NOX	COLOR	NO2
	-0.44283	-0.35153	0.24928	-0.24545	0.18902
	0.0001	0.0001	0.0001	0.0001	0.0065
	317	317	317	317	206
	FE	SECCHI	FTSI	TKN	CHLA
	-0.18630	0.18453	-0.16032	-0.15741	-0.14750
0.0009	0.0015	0.0042	0.0050	0.0085	
317	292	317	317	317	
Histosols	COLOR	FE	SECCHI	FTSI	TURB
	0.50197	0.39853	-0.36092	0.28059	0.26416
	0.0001	0.0001	0.0001	0.0019	0.0036
	120	120	116	120	120
	ORTP	SO4	TP	NH4	CHLA
	0.26235	-0.24281	0.24250	0.22374	0.21480
0.0038	0.0078	0.0076	0.0140	0.0185	
120	119	120	120	120	
Inceptisols	SO4	NH4	K	MG	ORTP
	-0.26687	0.25251	-0.25176	-0.23162	0.22295
	0.0016	0.0029	0.0030	0.0065	0.0088
	137	137	137	137	137
	COND	PHEO	TKN	COLOR	HARD
	-0.18930	0.18500	0.17249	0.16631	-0.15302
0.0267	0.0304	0.0439	0.0521	0.0742	
137	137	137	137	137	
Mollisols	COND	NO2	HARD	CA	COLOR
	-0.47709	-0.38302	-0.37676	-0.32893	0.32568
	0.0077	0.0486	0.0401	0.0759	0.0790
	30	27	30	30	30
	TALK	SO4	NOX	NA	PHEO
	-0.28282	-0.27840	-0.27607	-0.27458	0.26971
0.1299	0.1436	0.1398	0.1420	0.1495	
30	29	30	30	30	
Spodosols	NA	CL	MG	NO2	ORTP
	0.29471	0.25199	-0.21861	-0.20949	-0.17833
	0.0001	0.0001	0.0003	0.0042	0.0032
	271	271	271	185	271
	K	NH4	DO	TSS	PH
	-0.14855	0.14816	-0.13147	-0.12784	-0.12733
0.0144	0.0146	0.0308	0.0354	0.0362	
271	271	270	271	271	
Ultisols	TALK	CA	NA	PHEO	CHLA
	-0.19990	-0.17469	-0.17206	0.15834	0.14103
	0.0399	0.0733	0.0778	0.1050	0.1493
	106	106	106	106	106
	SECCHI	MG	DO	FTSI	NO3
	-0.13889	0.13627	0.13500	0.13311	0.13006
0.1771	0.1637	0.1677	0.1738	0.2090	
96	106	106	106	95	

Table 12. Spearman rank correlation coefficients (S, Prob>|R| under Ho: Rho=0, number of observations) for major land use classifications (DOT Level 1) with median lake water chemistry variables. CA=calcium K=potassium, TN=total nitrogen, SO4=sulfate, TALK=total alkalinity, MG=magnesium, NOX=nitrite+nitrate, TP=total phosphorus, TKN=total Kjeldahl nitrogen, FTSI=Florida trophic state index, NO2=nitrite, FE=iron, HARD=total hardness, PH=pH, COND=conductance, NA=sodium, TSS=total suspended solids, CHLA=chlorophyll a.

Urban and Built-up (100)	CA	K	TN	SO4	TALK
	0.24670	-0.23571	-0.19572	-0.18771	0.18637
	0.0001	0.0001	0.0006	0.0010	0.0010
	308	308	308	306	308
	MG	NOX	TP	TKN	FTSI
	-0.18513	-0.15196	0.12858	-0.10496	0.08707
	0.0011	0.0075	0.0240	0.0658	0.1273
	308	308	308	308	308
Agriculture (200)	TKN	SO4	SECCHI	NO2	K
	0.17699	-0.15620	-0.12956	-0.12607	-0.12220
	0.0038	0.0112	0.0423	0.0974	0.0469
	265	263	246	174	265
	FE	CA	HARD	MG	PH
	0.11819	-0.11239	-0.11183	-0.09689	-0.08994
	0.0547	0.0677	0.0691	0.1156	0.1443
	265	265	265	265	265
Citrus Groves (2200)	MG	K	SO4	HARD	COND
	0.67719	0.62341	0.60992	0.53284	0.52472
	0.0001	0.0001	0.0001	0.0001	0.0001
	222	222	221	222	217
	NOX	TN	NO2	SECCHI	NA
	0.51566	0.46057	0.37552	0.29887	-0.24172
	0.0001	0.0001	0.0001	0.0001	0.0003
	222	222	140	211	222
Range (300)	PH	TALK	CA	TKN	HARD
	-0.29162	-0.14642	-0.14395	0.14294	-0.11688
	0.0005	0.0832	0.0886	0.0909	0.1675
	141	141	141	141	141
	K	FTSI	NOX	MG	TSS
	-0.11471	-0.11108	-0.10841	-0.10308	-0.08350
	0.1756	0.1898	0.2007	0.2239	0.3249
	141	141	141	141	141
Upland Forest (400)	K	SO4	PH	MG	FE
	-0.29514	-0.26313	-0.13934	-0.12870	0.11325
	0.0001	0.0001	0.0276	0.0420	0.0739
	250	248	250	250	250
	NOX	TSS	COLOR	FTSI	CHLA
	-0.09617	-0.08999	0.08352	-0.08087	-0.07761
	0.1294	0.1560	0.1881	0.2025	0.2214
	250	250	250	250	250
Wetlands (500+600)	SECCHI	NOX	COLOR	TN	FTSI
	-0.23722	-0.20355	0.20095	-0.18292	0.14420
	0.0001	0.0002	0.0003	0.0010	0.0095
	298	323	323	323	323
	CA	NO2	FE	TSS	PH
	-0.13641	-0.13514	0.13140	0.10790	0.09955
	0.0141	0.0478	0.0181	0.0527	0.0740
	323	215	323	323	323

Table 13. Summary of relative lake water chemistry by Florida Lake Region (Griffith et al. 1997). "H" represents high, "L" is low. Where there is no letter shown, the values are intermediate and means of the ranked values may not be significantly different from those marked with "H" or "L". Refer to Figures 27 to 32 for plots of data interquartile ranges and results of Tukey's Studentized Range Test.

<u>Florida Lake Region</u>	<u>Total Phosphorus</u>	<u>Chlorophyll a</u>	<u>Florida TSI</u>	<u>Transparency</u>	<u>Total Suspended Solids</u>	<u>Turbidity</u>	<u>Conductivity</u>	<u>Nitrate-nitrite</u>	<u>Sulfate</u>	<u>Total Alkalinity</u>	<u>pH</u>
Lakeland/Bone Valley	H	H	H	L	H	H	L	L			H
Southern Lake Wales Ridge	L	L	L	H		L		H	H	L	
Keystone Lakes	L	L	L	H	L	L				L	L
Southwestern Flatlands	H	H	H	L	H	H		L			
Tsala Apopka					L	L	L	L	L	H	
Winter Haven /Lake Henry						H	H	L		H	H
Pinnelas Penninsula	H						H	L		H	H
Northern Lake Wales Ridge				H		L		H	H		
Southern Brooksville Ridge							L	L	L		
Weeki Wachee Hills		L	L				L				
Lake Wales Ridge										L	L
Hillsborough Valley	H			L			L				
Tampa Plain											L
Land o' Lakes											

Figure 1. Distribution of Florida Trophic State Index (FTSI) in the sample lakes (n=323). Values are medians of all samples collected for each lake.

Percentile Distribution of Florida Trophic State Index for Sampled Lakes, and for Florida Lakes:

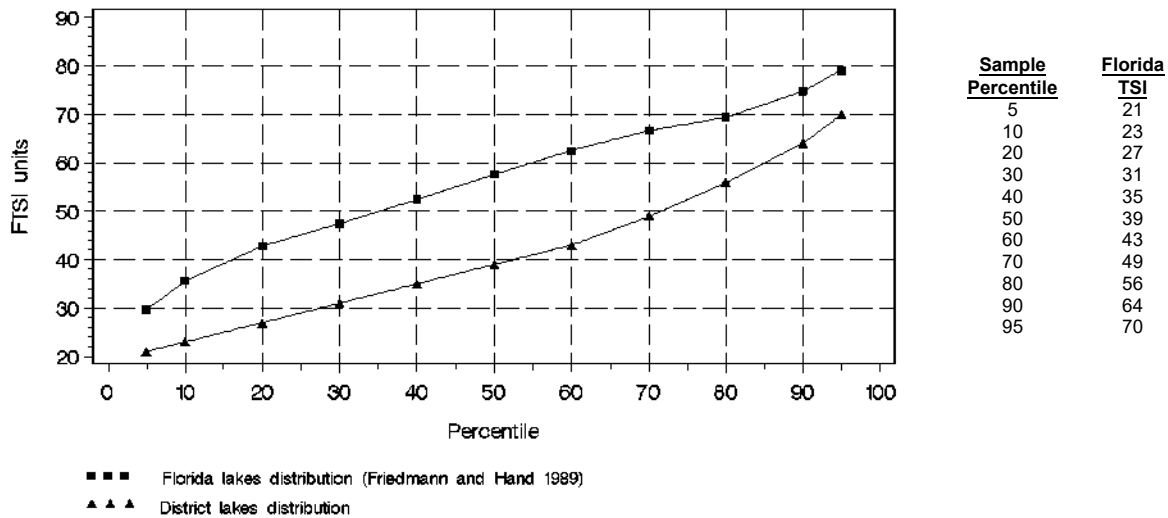

Sampled Lakes with the Greatest Median Florida TSI:

Lake Name	County	Florida TSI
Lake Effie	Polk	89
Pasadena Lake	Pinellas	87
Sparkman Lake	Hernando	81
Persimmon Lake	Highlands	80
Lake Garfield	Polk	77
Lester Lake	Polk	76
McClendon Lake	Hernando	75
Lake Galloway	Polk	74
Irvin Lake	Hernando	73
Lake Conine	Polk	73
Lake Maggiore	Pinellas	73
Lake Haines	Polk	72
Lake Shipp	Polk	72
Lake Hancock	Polk	72
Bellows (East) Lake	Hillsborough	71

Sampled Lakes with the Lowest Median Florida TSI:

Lake Name	County	Florida TSI
Buck Lake	Highlands	12
Lake Rogers	Hillsborough	13
Lake Simmons	Highlands	13
Lake Lynn	Highlands	15
Mirror Lake	Highlands	17
Lake Isis	Highlands	17
Lake Sirena	Highlands	18
Treasure Lake	Pasco	18
Silver Lake	Highlands	19
Turtle Lake	Pasco	19
Lake Viola	Highlands	19
Lake Denton	Highlands	19
Gooseneck Lake	Pasco	20
Trout Lake	Polk	20
Lake Tulane	Highlands	20
Lake Schumacher	Highlands	20

Figure 2. Distribution of Chlorophyll *a* (ug/l) in the sample lakes (n=323). Values are medians of all samples collected for each lake.

Percentile Distribution of Chlorophyll *a* for Sampled Lakes, and for Florida Lakes:

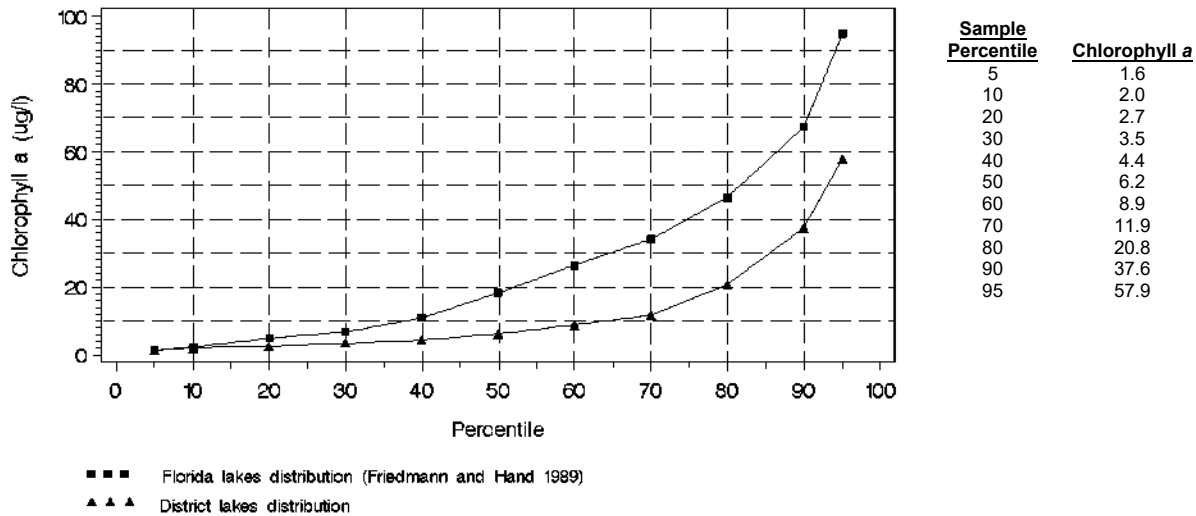

Sampled Lakes with the Greatest Median Concentrations of Chlorophyll *a*:

Lake Name	County	Chlorophyll <i>a</i>
Lake Effie	Polk	146.8
McClendon Lake	Hernando	122.4
Pasadena Lake	Pinellas	121.6
Lake Maggiore	Pinellas	104.7
Lake Haines	Polk	98.1
Persimmon Lake	Highlands	96.7
Sparkman Lake	Hernando	91.4
Lester Lake	Polk	84.5
Lake Conine	Polk	82.0
Lake Hancock	Polk	80.5
Lake Shipp	Polk	75.2
Lake Gibson	Polk	74.5
Lake Galloway	Polk	67.2
Scott Lake	Polk	65.9
Holden Lake	Citrus	64.2
Bellows (East) Lake	Hillsborough	58.7

Sampled Lakes with the Lowest Median Concentrations of Chlorophyll *a*:

Lake Name	County	Chlorophyll <i>a</i>
Lake Schumacher	Highlands	1.0
Buck Lake	Highlands	1.0
Lake Rogers	Hillsborough	1.0
Lake Lynn	Highlands	1.0
Blue Lake (Little)	Polk	1.0
Magnolia Lake	Citrus	1.0
Treasure Lake	Pasco	1.1
Moody Lake (East)	Pasco	1.1
Turkey Ford Lake	Hillsborough	1.1
Lake Simmons	Highlands	1.2
Little Halfmoon Lake	Hillsborough	1.2
Lake Pearl	Highlands	1.2
Lake Isis	Highlands	1.2
Lake McCoy	Highlands	1.4
Lake Byrd	Highlands	1.5
Unnamed Lake	Hernando	1.5

Figure 3. Distribution of color (PtCo units) in the sample lakes (n=323). Values are medians of all samples collected for each lake.

Percentile Distribution of Color for Sampled Lakes, and for Florida Lakes:

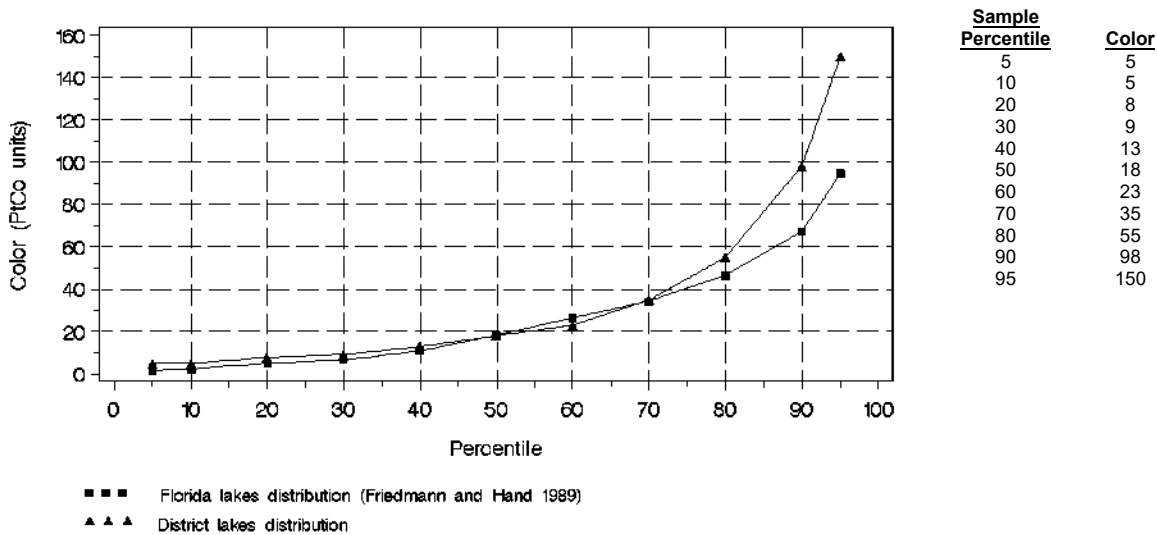

Sampled Lakes with the Greatest Median Color:

Lake Name	County	Color
Wolf Lake	Highlands	289
Lake Henry	Polk	275
Lake Galloway	Polk	250
Sparkman Lake	Hernando	250
Grassy Pond	Highlands	238
Lake Gordon	Polk	213
Lake Streety	Polk	213
Lake Worrell	Pasco	188
Lake Garfield	Polk	188
August Lake	Highlands	175
Lake Carrie	Highlands	175
Lake Geneva	Hernando	172
Lake Josephine West	Highlands	168
Floral City Lake	Citrus	163
Stormwater Pond	Highlands	163
Lake Sebring	Highlands	163

Sampled Lakes with the Lowest Median Color (Color <=5 PtCo units):

Highlands	Lake June in Winter	Lake Simmons	Pasco
Lake Anoka	Lake Lachard	Lake Sirena	Bell Lake
Basket Lake	Lake Letta	Lake Tulane	East (Cow) Lake
Blue Lake	Lake Lillian	Unnamed "B" Lake	Lake Iola
Brentwood Lake	Lost Lake	Unnamed "E" Lake	
Buck Lake	Lake Lotela	Lake Verona	Pinellas
Lake Byrd	Lake Lynn	Lake Viola	Crest Lake
Lake Clay	Lake McCoy		
Deer Lake	Mirror Lake	Hillsborough	Polk
Lake Denton	Lake Nellie Center	Lake Alice	Lake Arietta
Dinner Lake	Lake Nellie NW	Calm Lake	Blue Lake (Big)
Lake Francis	Lake Nellie SE	Lake Eva	Blue Lake (Little)
Lake Harry	Lake Pearl	Lake Juanita	Cypress Lake
Lake Henry	Lake Placid	Lake Rogers	Eagle Lake
Lake Huntley	Saddlebags Lake	White Trout Lake	Trout Lake
Lake Isis	Silver Lake		

Figure 4. Distribution of specific conductance (uS/cm @ 25 C) in the sample lakes (n=323). Values are medians of all samples collected for each lake.

Percentile Distribution of Specific Conductance for Sampled Lakes, and for Florida Lakes:

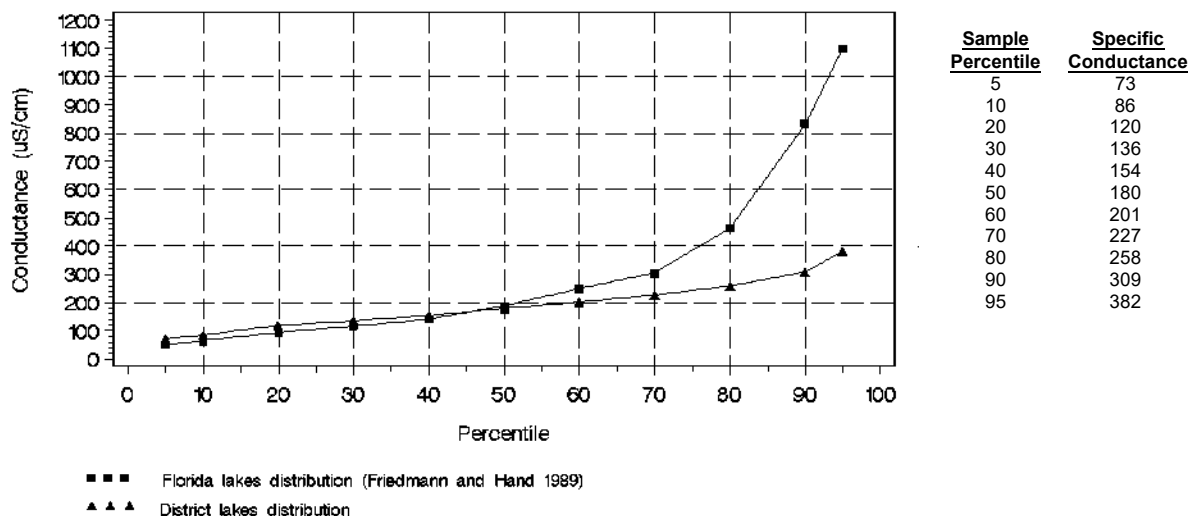

Sampled Lakes with the Greatest Median Specific Conductance:

Lake Name	County	Conductance
Lake Maggiore	Pinellas	6645
Lake Anoka	Highlands	1284
Duck Lake	Highlands	1071
Lake Eva	Hillsborough	962
Gant Lake	Hillsborough	724
Lake Lucas	Highlands	616
Taylor Lake	Pinellas	478
Lake Schumacher	Highlands	459
Lake Hickory	Polk	442
Lake Simmons	Highlands	431
Lake Moody	Polk	428
Sawgrass Lake	Pinellas	416
Basket Lake	Highlands	405
Grassy Pond	Highlands	401
Lake Nellie SE	Highlands	391
Lake Ruby	Polk	386

Sampled Lakes with the Lowest Median Specific Conductance:

Lake Name	County	Conductance
Lake Marion	Levy	25
McKethan Lake	Hernando	33
Little Bream Lake	Marion	40
Rush Lake	Citrus	41
Lake Lindsey	Hernando	42
Tiger Lake	Marion	49
Lake Hill	Highlands	50
Bonable Lake	Marion	51
Lake Ruth	Highlands	53
Little Bonable Lake	Marion	55
Chilton Lake	Highlands	57
Tank Lake	Hernando	58
Pierce Lake	Pasco	59
Rock Pond	Hernando	66
Lake Davenport	Polk	68

Figure 5. Distribution of total hardness (mg/l as CaCO₃) in the sample lakes (n=323). Values are medians of all samples collected for each lake.

Percentile Distribution of Total Hardness for Sampled Lakes:

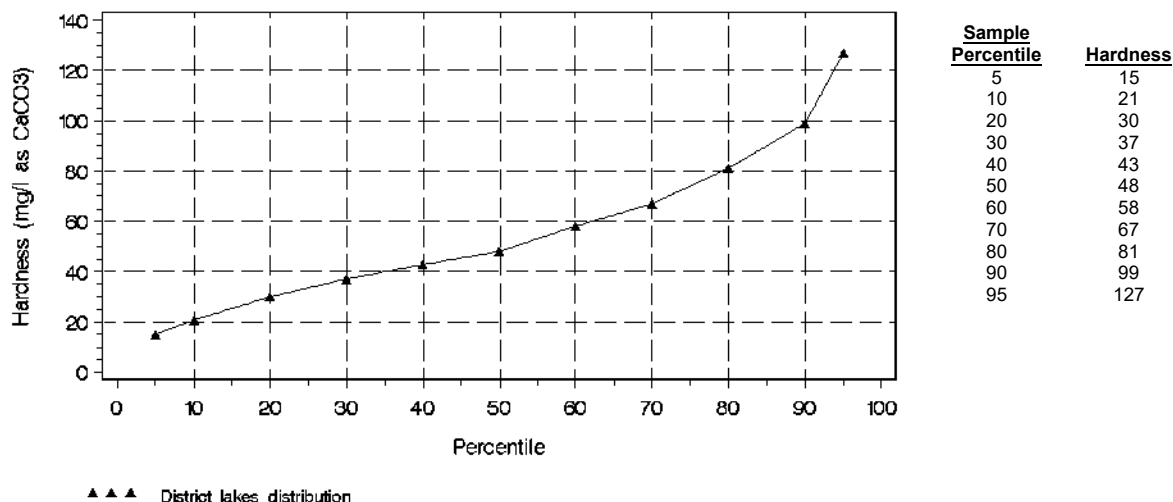

Sampled Lakes with the Greatest Median Total Hardness:

<u>Lake Name</u>	<u>County</u>	<u>Total Hardness</u>
Lake Maggiore	Pinellas	865
Lake Hickory	Polk	178
Taylor Lake	Pinellas	171
Lake Moody	Polk	170
Lake Simmons	Highlands	163
Sawgrass Lake	Pinellas	155
Reedy Lake	Polk	150
Basket Lake	Highlands	149
Magnolia Lake	Citrus	148
Big Gant Lake	Sumter	135
Lake Ruby	Polk	134
Cato Lake	Citrus	132
Lake Nellie SE	Highlands	131
Persimmon Lake	Highlands	129
Lake Leonore	Polk	129

Sampled Lakes with the Lowest Median Total Hardness:

<u>Lake Name</u>	<u>County</u>	<u>Total Hardness</u>
Grassy Pond	Highlands	5.0
Lake Schumacher	Highlands	5.0
Lake Marion	Levy	7.0
Rush Lake	Citrus	7.0
Lake Hill	Highlands	8.0
Lake Ruth	Highlands	10.0
Chilton Lake	Highlands	10.0
Lake Crews	Highlands	11.0
Tiger Lake	Marion	11.0
Lake Charlotte	Highlands	12.0
Bonable Lake	Marion	12.0
Pierce Lake	Pasco	12.0
Silver Lake	Highlands	13.0
Little Bonable Lake	Marion	13.0
Little Red Water Lake	Highlands	13.0

Figure 6. Distribution of pH in the sample lakes (n=323). Values are medians of all samples collected for each lake.

Percentile Distribution of pH for Sampled Lakes, and for Florida Lakes:

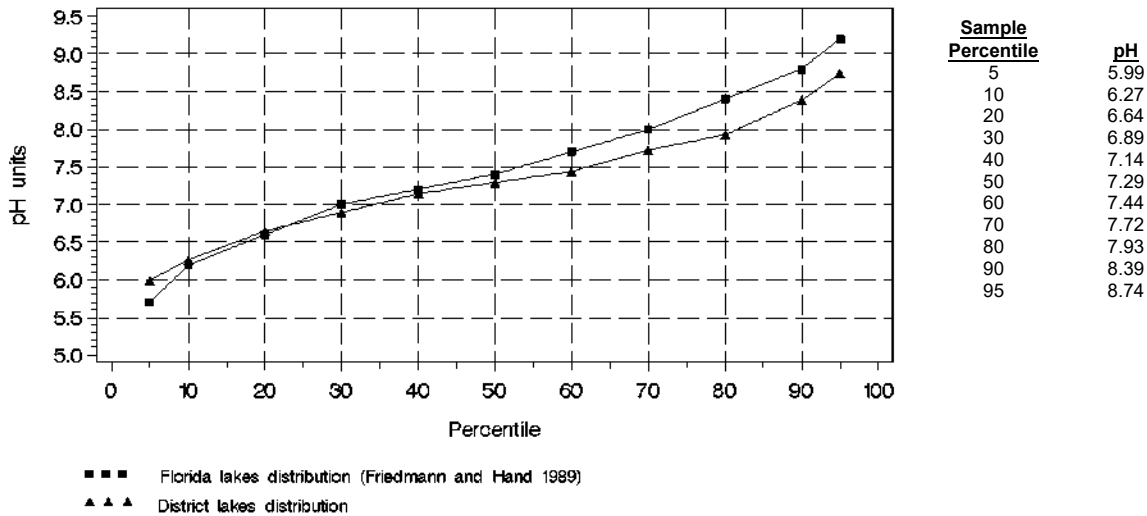

Sampled Lakes with the Greatest Median pH:

Lake Name	County	pH
Lake Hancock	Polk	10.0
Bellows (East) Lake	Hillsborough	9.55
Pasadena Lake	Pinellas	9.27
Lake Effie	Polk	9.25
Lake Conine	Polk	9.14
Lake Rochelle	Polk	9.11
Lake Haines	Polk	9.08
Scott Lake	Polk	8.96
Lake Howard	Polk	8.93
Lake Ariana	Polk	8.88
Lake Lena	Polk	8.86
Lake Hancock	Pasco	8.80
Lake Pasadena	Pasco	8.80
Lake Jessie	Polk	8.78
Lake Bonny	Polk	8.77
Mud Lake	Polk	8.75

Sampled Lakes with the Lowest Median pH:

Lake Name	County	pH
Lake Ruth	Highlands	4.44
Silver Lake	Highlands	4.45
Lake Charlotte	Highlands	4.52
Lake Alice	Hillsborough	4.54
Grassy Pond	Highlands	4.55
Lake Schumacher	Highlands	4.78
Thorpe Lake	Hillsborough	5.20
Lake Hill	Highlands	5.28
Lake Marion	Levy	5.59
Wolf Lake	Highlands	5.59
Lake Raleigh	Hillsborough	5.60
Huckleberry Lake	Highlands	5.78
Crescent Lake	Hillsborough	5.81
Lake Reinheimer	Hillsborough	5.89
Little Deer Lake	Hillsborough	5.92
Lake Adelaide	Highlands	5.94
Lake Wimauma	Hillsborough	5.99

Figure 7. Distribution of transparency (Secchi depth, meters) in the sample lakes (n=323). Values are medians of all samples collected for each lake.

Percentile Distribution of Secchi Depth for Sampled Lakes, and for Florida Lakes:

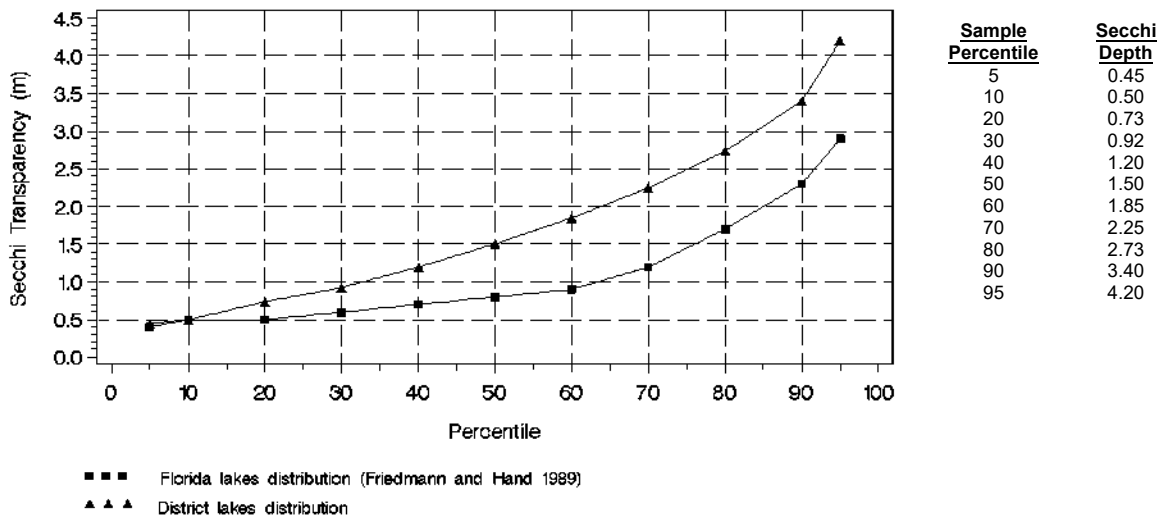

Sampled Lakes with the Greatest Median Secchi Depth:

Lake Name	County	Secchi Depth
Lake Isis	Highlands	8.05
Buck Lake	Highlands	7.65
Blue Lake (Little)	Polk	7.30
Lake Denton	Highlands	6.55
Lake Simmons	Highlands	6.25
Lost Lake	Highlands	6.00
Lake Tulane	Highlands	5.57
Lake Viola	Highlands	5.40
Lake Alice	Hillsborough	5.00
Mirror Lake	Highlands	4.55
Lake Thomas	Pasco	4.43
Blue Lake (Big)	Polk	4.40
Lake Sirena	Highlands	4.40
Silver Lake	Highlands	4.35
Lake Lillian	Highlands	4.20
Grace Lake	Hillsborough	4.20

Sampled Lakes with the Lowest Median Secchi Depth:

Lake Name	County	Secchi Depth
Lake Effie	Polk	0.20
McClendon Lake	Hernando	0.25
Lake Hancock	Polk	0.27
Grassy Pond	Highlands	0.30
Lake Josephine Center	Highlands	0.30
Lake Garfield	Polk	0.31
Persimmon Lake	Highlands	0.32
Lester Lake	Polk	0.35
Pasadena Lake	Pinellas	0.35
Wolf Lake	Highlands	0.38
Lake Henry	Polk	0.40
Sparkman Lake	Hernando	0.40
Bellows (East) Lake	Hillsborough	0.43
Gadau Lake	Polk	0.45
Lake Hickory	Polk	0.45
Lake Carrie	Highlands	0.46

Figure 8. Distribution of total nitrogen (concentration, mg/l as N) in the sample lakes (n=323). Values are medians of all samples collected for each lake.

Percentile Distribution of Total Nitrogen for Sampled Lakes, and for Florida Lakes:

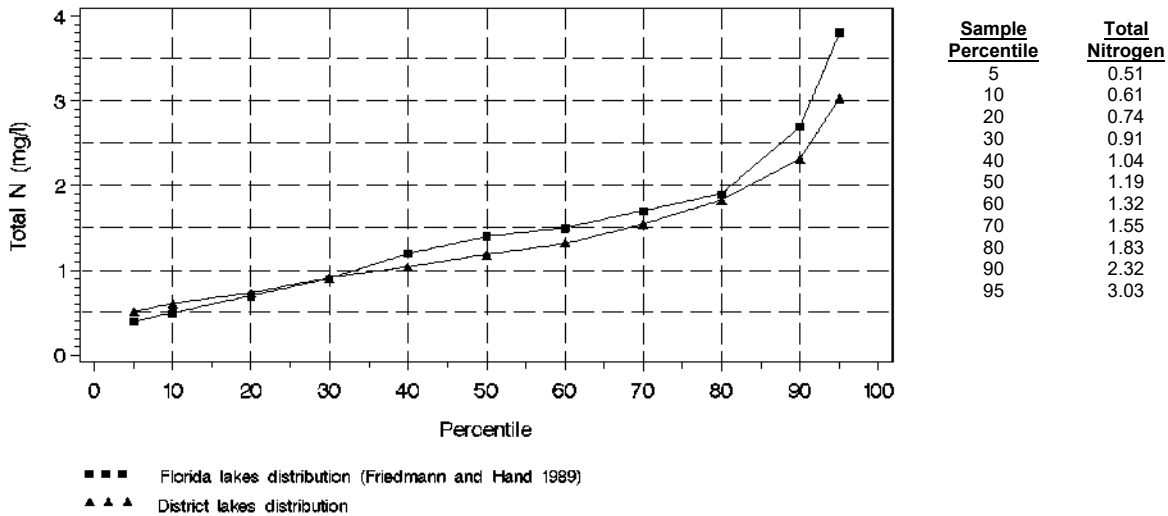

Sampled Lakes with the Greatest Median Concentrations of Total N:

Lake Name	County	Total Nitrogen
Buck Lake	Highlands	7.75
Lake Denton	Highlands	7.64
Lake Simmons	Highlands	7.15
Lake Ida (Frostproof)	Polk	6.21
Lost Lake	Highlands	5.46
Lake Byrd	Highlands	4.95
Blue Lake (Little)	Polk	4.79
Lake Lynn	Highlands	4.75
Lake Isis	Highlands	4.35
Lake Nellie SE	Highlands	4.13
Basket Lake	Highlands	3.66
Brentwood Lake	Highlands	3.55
Lake Effie	Polk	3.51
Little Bonnet Lake	Highlands	3.24
Pasadena Lake	Pinellas	3.20
Lake Hickory	Polk	3.05
Persimmon Lake	Highlands	3.03

Sampled Lakes with the Lowest Median Concentrations of Total N:

Lake Name	County	Total Nitrogen
Lake Eva	Hillsborough	0.31
Huckleberry Lake	Highlands	0.37
Lake Daisy	Polk	0.38
Calm Lake	Hillsborough	0.40
Lake Helen	Hillsborough	0.41
Little Red Water Lak	Highlands	0.44
Lake Huntley	Highlands	0.45
Grace Lake	Hillsborough	0.45
Crooked Lake	Polk	0.45
August Lake	Highlands	0.47
Lake Jackson	Highlands	0.48
Big Lake Vienna	Pasco	0.49
Lake Placid	Highlands	0.49
Bell Lake	Pasco	0.49
Lake Adelaide	Highlands	0.51
Vienna Lake	Pasco	0.51

Figure 9. Distribution of total alkalinity (mg/l as CaCO₃) in the sample lakes (n=323). Values are medians of all samples collected for each lake.

Percentile Distribution of Total Alkalinity for Sampled Lakes, and for Florida Lakes:

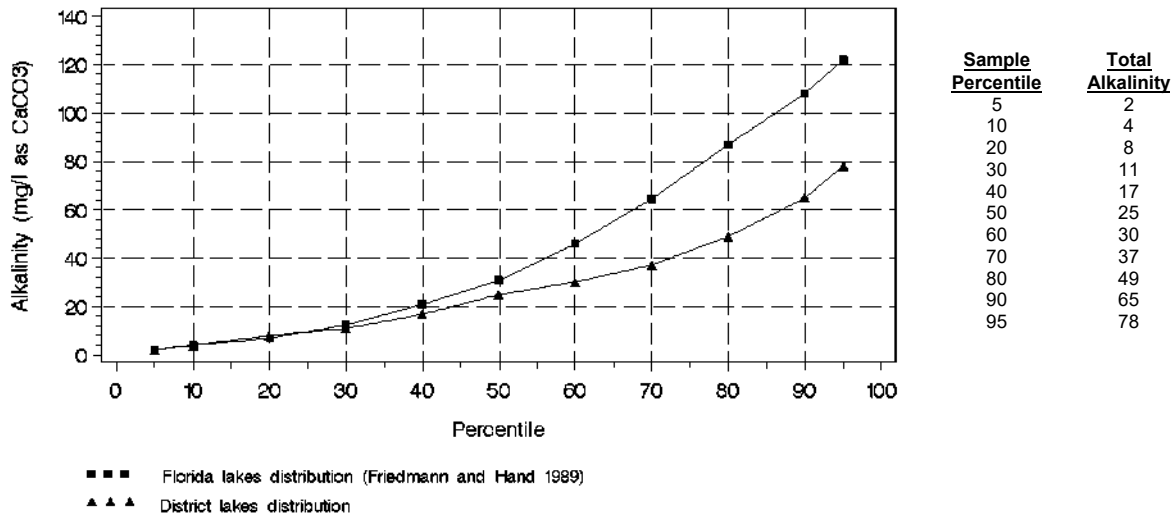

Sampled Lakes with the Greatest Median Total Alkalinity:

Lake Name	County	Total Alkalinity
Big Gant Lake	Sumter	217
Cato Lake	Citrus	164
Magnolia Lake	Citrus	151
Taylor Lake	Pinellas	133
Lake Effie	Polk	126
Sawgrass Lake	Pinellas	118
Round Lake	Hillsborough	110
Fort Cooper Lake	Citrus	108
Lake Maggiore	Pinellas	107
Alligator Lake	Pinellas	97
Lake Swoope	Polk	96
Unnamed Pasco Lake	Pasco	90

Sampled Lakes with the Lowest Median Total Alkalinity:

Lake Name	County	Total Alkalinity
Lake Charlotte	Highlands	0.0
Lake Alice	Hillsborough	0.0
Lake Reinheimer	Hillsborough	1.0
Lake Huntley	Highlands	1.0
Lake Raleigh	Hillsborough	1.0
Silver Lake	Highlands	1.0
Lake Adelaide	Highlands	2.0
Lake Buffum	Polk	2.0
Crescent Lake	Hillsborough	2.0
Lake Crews	Highlands	2.0
Grassy Pond	Highlands	2.0
Island Ford Lake	Hillsborough	2.0
Little Deer Lake	Hillsborough	2.0
Lake Marion	Levy	2.0
Lake Ruth	Highlands	2.0
Thorpe Lake	Hillsborough	2.0
Tiger Lake	Marion	2.0
Lake Schumacher	Highlands	2.0
Lake Wimauma	Hillsborough	2.0

Figure 10. Distribution of total phosphorus (mg/l as P) in the sample lakes (n=323). Values are medians of all samples collected for each lake. Many lakes had concentrations less than the detection limit for total P (0.01 mg/l).

Percentile Distribution of Total P Concentrations for Sampled Lakes, and for Florida Lakes:

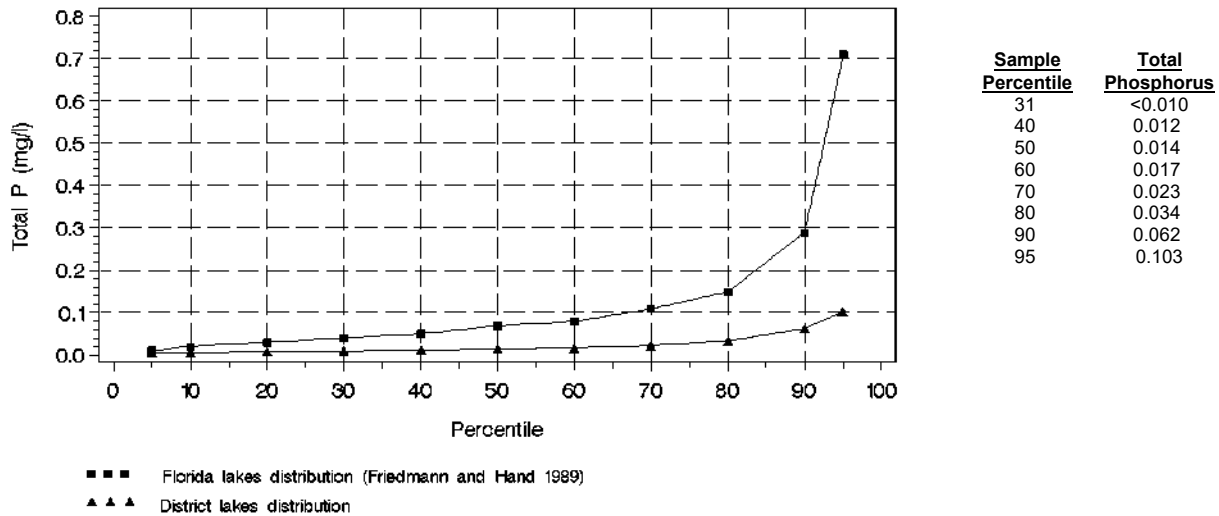

Lakes with Median Total Phosphorus Concentrations <=0.01 mg/l:

<u>Citrus</u> Connell Cooter Croft Davis Hampton Little Henderson Rush Spivey Todd Van Ness	<u>Highlands</u> Adelaide Anoka Apthorpe Basket Blue Brentwood Buck Byrd Clay Denton Dinner Fox Grassy Harry Henry Hill	Hog (Granada) June in Winter Lachard Lillian Little Red Water-N Little Red Water-S Lost Lucas Lynn McCoy Mirror Nellie SE Olivia Pearl Red Water Ruth Saddlebags	Silver Simmons Sirena Tulane Unnamed "B" Schumacher Verona Viola	<u>Hillsborough</u> Alice Calm Carroll Church Crescent Cypress Deer	Ellen Gant Grace Halfmoon Horse Juanita Keystone Little Halfmoon Magdalene Marlee Rainbow Raleigh Rogers Round Starvation Thorpe	Wastena White Trout Williams Wood	<u>Levy</u> Marion	<u>Pasco</u> Banjo Big Vienna Blanton Crews Dowling Gooseneck Iola King	Loyce Moody (West) Moon Moss Pasadena Pierce Sumner Thomas Treasure Turtle Twin West Moon Wistaria	<u>Polk</u> Ariana Arietta Clinch Crooked Daisy Davenport Echo Elbert Leonore Pabor Reedy Trout Wales
---	---	--	---	--	---	--	-----------------------	---	--	--

Sampled Lakes with the Greatest Median Concentrations of Total Phosphorus:

Lake Name	County	Total Phosphorus
Lake Bernadette	Pasco	0.23
Huckleberry Lake	Highlands	0.23
Lake Galloway	Polk	0.22
Wolf Lake	Highlands	0.22
Irvin Lake	Hernando	0.19
Lake Maggiore	Pinellas	0.18
Lake Glenada	Highlands	0.18
Pasadena Lake	Pinellas	0.18
Lake Hancock	Polk	0.14
Lake Henry	Polk	0.14
Lake Streety	Polk	0.13
Crescent Lake	Pinellas	0.13
Bystre Lake	Hernando	0.12
Lake Weeks	Hillsborough	0.12
Alligator Lake	Pinellas	0.12

Figure 11. Distribution of total suspended solids (concentration, mg/l) in the sample lakes (n=323). Values are medians of all samples collected for each lake.

Percentile Distribution of Total Suspended Solids for Sampled Lakes, and for Florida Lakes:

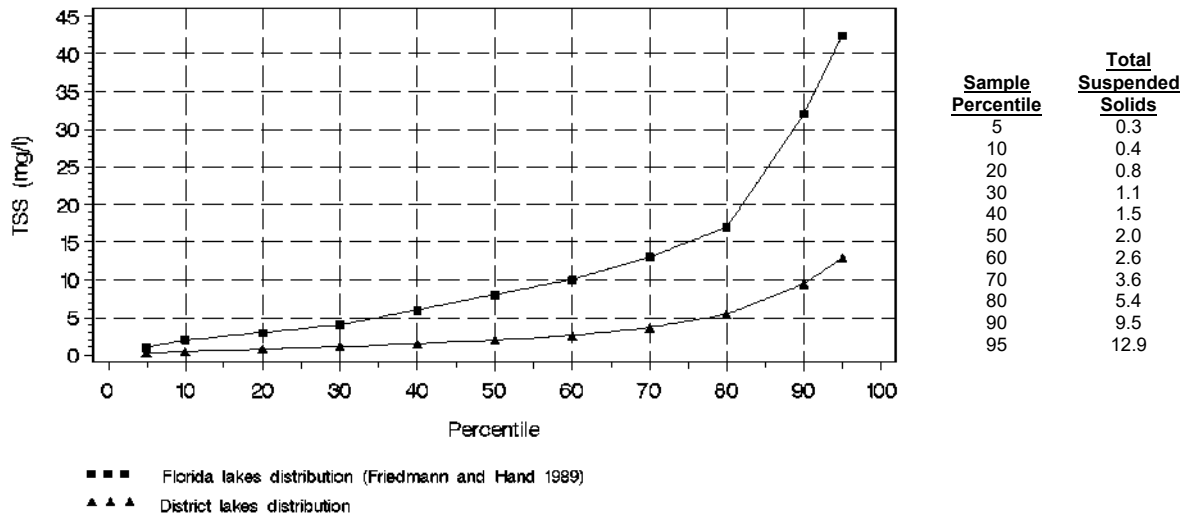

Sampled Lakes with the Greatest Median Total Suspended Solids:

Lake Name	County	TSS
Lake Hancock	Polk	47.2
Pasadena Lake	Pinellas	32.2
Bellows (East) Lake	Hillsborough	30.4
Lake Van	Polk	21.2
Lake Shipp	Polk	20.5
Persimmon Lake	Highlands	18.4
Lake Maggiore	Pinellas	17.5
Lake Conine	Polk	17.3
Lake Haines	Polk	16.6
Lake May	Polk	15.8
Lake Garfield	Polk	15.5
Lake Bonny	Polk	14.8
Lake Lulu	Polk	14.7
Scott Lake	Polk	13.7
Bonnett Pond	Hernando	13.2

Sampled Lakes with the Lowest Median Total Suspended Solids:

Lake Name	County	TSS
Sumner Lake	Pasco	0.0
Cypress Lake	Polk	0.0
Blue Lake (Little)	Polk	0.0
Magnolia Lake	Citrus	0.1
Lake Schumacher	Highlands	0.2
Bellamy Lake	Citrus	0.2
Croft Lake	Citrus	0.2
Twin Lake	Pasco	0.2
Cooter Lake	Citrus	0.2
Blue Lake (Big)	Polk	0.2
Lake Alice	Hillsborough	0.3
Wood Lake	Hillsborough	0.3
Dodd Lake	Citrus	0.3
Little Halfmoon Lake	Hillsborough	0.3
Marlee Lake	Hillsborough	0.3
Van Ness Lake	Citrus	0.3
Lake Chautauqua	Pinellas	0.3
Buck Lake	Highlands	0.3

Figure 12. Distribution of turbidity in the sample lakes (n=323). Values are medians of all samples collected for each lake.

Percentile Distribution of Turbidity for Sampled Lakes, and for Florida Lakes:

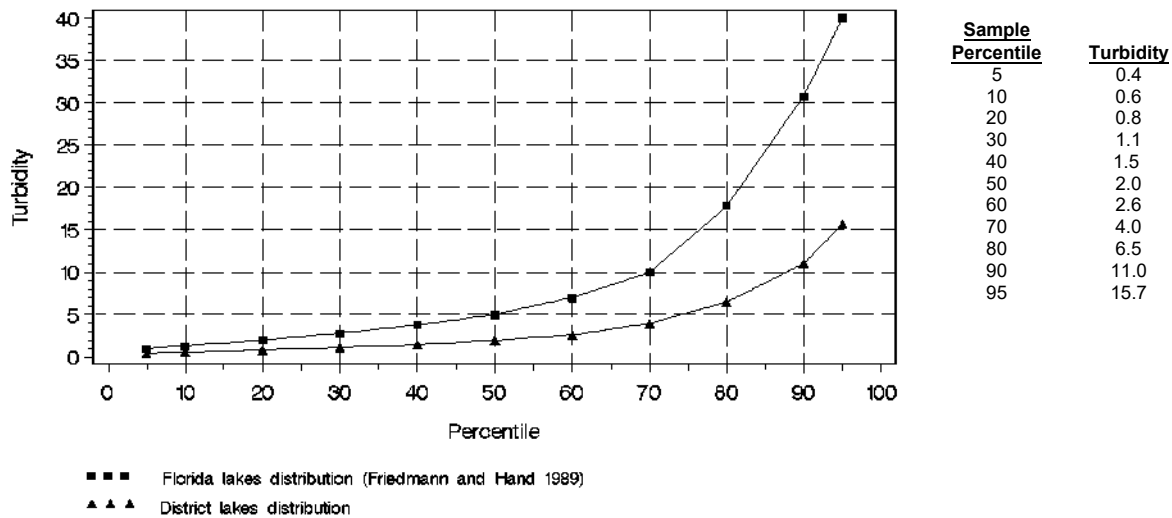

Sampled Lakes with the Greatest Median Turbidity:

Lake Name	County	Turbidity
Pasadena Lake	Pinellas	31.9
Persimmon Lake	Highlands	30.2
Lake Haines	Polk	26.2
Lester Lake	Polk	24.9
Lake Effie	Polk	24.5
Lake Hancock	Polk	23.5
Double Cypress Pond	Hernando	21.2
Lake Hickory	Polk	19.8
Bellows (East) Lake	Hillsborough	18.8
Wolf Lake	Highlands	18.4
Lake Conine	Polk	18.3
Lake Garfield	Polk	18.3
Pansy Lake	Highlands	17.3
Lake Tennessee	Polk	17.1
Jessamine Lake	Pasco	16.9
Lake Idyl	Polk	16.6

Sampled Lakes with the Lowest Median Turbidity:

Lake Name	County	Turbidity
Buck Lake	Highlands	0.1
Lake Simmons	Highlands	0.2
Lake Isis	Highlands	0.2
Lake Denton	Highlands	0.3
Lake Alice	Hillsborough	0.3
Blue Lake (Little)	Polk	0.3
Cooter Lake	Citrus	0.3
Lake Lynn	Highlands	0.4
Lake Schumacher	Highlands	0.4
Lost Lake	Highlands	0.4
Moody Lake (West)	Pasco	0.4
Lake McCoy	Highlands	0.4
Little Halfmoon Lake	Hillsborough	0.4
Little Moon Lake	Hillsborough	0.4
Lake Byrd	Highlands	0.4
Highland Lake	Hernando	0.4
Magnolia Lake	Citrus	0.4

Figure 13. Prevalent chemical type of water in the 323 sample lakes. Axes are percent of total cationic composition (Ca, Mg, Na and K), and percent of total anionic composition (SO₄, Cl, CO₃, HCO₃).

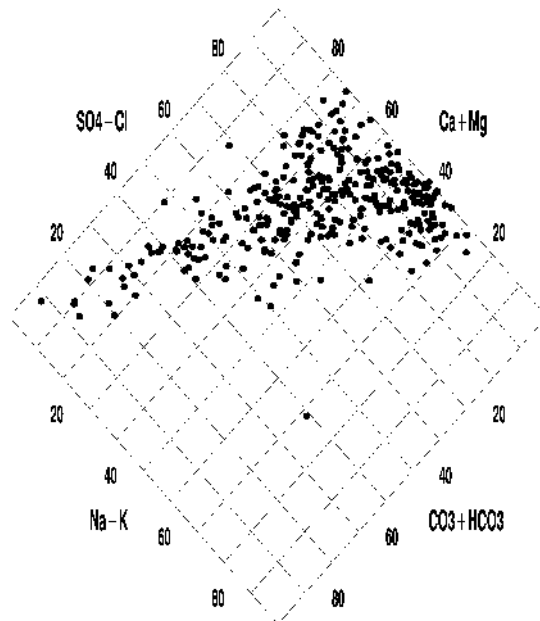

Ca and Mg Sulfate

- Raleigh-Hills.
- Reinheimer-Hills.
- Little Deer-Hills.
- Crescent-Hills.
- Parker-Polk
- Calm-Hills.
- Lost-High.
- Horse-Hills.
- Trout-Polk
- Josephine East-High.
- Church-Hills.
- King-Pasco
- Rogers-Hills.
- Henry-High.
- Francis-High.
- Buck-High.
- Merrywater-Hills.
- NellieSE-High.
- Pythias-High.
- Turtle(Tampa)-Pasco
- Byrd-High.
- Tooke-Hern.
- Wastena-Hills.
- Tiger-Marion
- Marlee-Hills.
- Gordon(SW)-Polk
- Apthorpe-High.
- Marion-Levy
- Lit. Red Water S-High.
- Nellie Center-High.
- Nellie NW-High.
- Saddlebags-High.
- Red Water-High.
- Deer-High.
- June in Winter-High.
- Pearl-High.
- Hog Island-Hills.
- Lit. Bonable-Marion
- Bess-Polk
- Basket-High.
- Crest-Pnls.
- Bonable-Marion
- Surveyors-Polk
- Persimmon-High.
- Little Bonnet-High.
- Blue-High.
- Gadau-Polk
- Damon-High.
- Brentwood-High.
- Unnamed B-High.
- Josephine W-High.
- Josephine C-High.
- Harry-High.

- Isis-High.
- Dowling-Pasco
- Eagle-Polk
- West Moon-Pasco
- Gant-Hills.
- Lit. Jackson-High.
- Simmons-High.
- Ruby-Polk
- Sirena-High.
- Denton-High.
- Grassy-High.
- Bonnet-High.
- Stemper-Hills.
- Pasadena-Pasco
- Juliana-Polk
- Lelia-High.
- Pansy-Polk
- Blue(Little)-Polk
- Davenport-Polk
- Spirit-Polk
- Ida(Frostproof)-Polk
- Mabel-Polk
- McCoy-High.
- Isabell-Hills.
- Starr-Polk
- August-High.
- GoldenTrout-Hills.
- Carrie-High.
- Reedy-Polk
- Leonore-Polk
- Platt-Hills.
- Ariana-Polk
- Blue(Big)-Polk
- Viola-High.
- Tulane-High.
- Carroll-Hills.
- Blanton-Pasco
- Tennessee-Polk
- Moss-Pasco
- Moody-Polk
- Lena-Polk
- WhiteTrout-Hills.
- Lillian-High.
- Dbl. Cypress-Hern.
- Hickory-Polk
- Wistaria-Pasco
- Brant-Hills.
- Dinner-High.
- McLeod-Polk
- Zambito-Hills.
- Winterset-Polk
- Lester-Polk
- Jackson-Hills.
- Long Pond-Hills.

- Lynn-High.
- Ellen-Hills.
- Cypress-Polk
- Spring-Hern.
- Sunset-Hills.
- Chapman-Hills.
- Mud-Polk
- Eckles-Hills.
- Chapman-Hills.
- Fox-High.
- Gibson-Polk
- Floyd-Pasco
- Lachard-High.
- Hancock-Pasco
- Stormwater Pond-High.
- Miona-Sumter
- Estes-Hills.
- Hunters-Hern.
- Magdalen-Hills.
- Bay-Hills.
- Cedar East-Hills.
- Anoka-High.
- King-Pasco
- Treasure-Pasco
- Isabell-Polk
- Scott-Polk
- Elbert-Polk
- Freedom-Pnls.
- Mango-Hills.
- Black-Pasco
- Idyl-Polk
- Pansy-High.
- Eloise-Polk
- Middle-Pasco
- Bell-Pasco
- (West)-Pasco
- Beckett-Pnls.
- Starvation-Hills.
- Bernadette-Pasco
- Mead-Hills.
- Twin-Hills.
- Sparkman-Hern.
- Bowden-Pnls.
- Verona-High.
- Angelo-High.
- Lit. Bream-Marion
- Ellen(M)-Hills.
- Jessamine-Pasco
- Egypt-Hills.
- Bird-Pasco
- Duck-High.
- Jessie-Polk
- Alligator-Pnls.
- Sumner-Pasco
- Crescent-Pnls.

- Idylwild-Polk
- McClendon-Hern.
- Hartridge-Polk
- Lulu-Polk
- Moody E-Pasco
- Okahumpka-Sumt.
- Fannie-Polk
- Deeson-Polk
- Gooseneck-Pasco
- Taylor-Pnls.
- Twin-Pasco
- Tank-Hern.
- Harbor-Pnls.
- Shipp-Polk
- Cannon-Polk
- May-Polk
- Echo-Polk
- Worrell-Pasco
- Banjo-Pasco
- Sawgrass-Pnls.
- Galloway-Polk
- Valrico-Hills.
- Conine-Polk
- Howard-Polk
- StGeorge-Pnls.
- Rochelle-Polk
- Tenmile-Hills.
- Highland-Hern.
- Wales-Polk
- Bonny-Polk
- Bellows-Hills.
- Ida(Winter Haven)-Polk
- Pasadena-Pnls.
- Pabor-Polk
- Hern.-Citrus
- Crews-Pasco
- Swoope-Polk
- Sodium Chloride**
- Lucas-High.
- Red Beach-High.
- Alfred-Polk
- Sunshine-Hills.
- Cedar-Hills.
- Hill-High.
- Glenada-High.
- Deaton-Sumter
- Moon-Pasco
- Hamilton-Polk
- Dosson-Hills.
- Pretty-Hills.
- Thomas-Pasco
- Sapphire-Hills.
- Weeks-Hills.
- Olivia-High.

- East-Pasco
- Ellen (R)-Hills.
- Fishing-Pasco
- Pierce-Pasco
- Barbara-Hills.
- Williams-Hills.
- Garfield-Polk
- Gornto-Hills.
- Eva-Hills.
- Helen-Hills.
- Grace-Hills.
- Green-Pasco
- Gordon-Polk
- Henry-Polk
- Rainbow-Hills.
- Big Vienna-Pasco
- Mattie-Polk
- Allen-Hills.
- Parker-Pasco
- Streety-Polk
- Iola-Pasco
- Chilton-High.
- Grassy Pond-High.
- Taylor-Hills.
- Turkey Ford-Hills.
- Clinch-Polk
- Agnes-Polk
- Sebring-High.
- Deer-Hills.
- Lit. Red Water N-High.
- Myrtle-Polk
- Crooked-Polk
- Vienna-Pasco
- Van-Polk
- Juanita-Hills.
- Lit. Crooked-Polk
- Unnamed X-High.
- Huckleberry-High.
- Lit. Halfmoon-Hills.
- Wolf-High.
- Crews-High.
- Wood-Hills.
- Mirror-High.
- Padgett-Pasco
- Clay-High.
- Little Moon-Hills.
- Halfmoon-Hills.
- Keystone-Hills.
- Adelaide-High.
- Lotela-High.
- Daisy-Polk
- Jackson-High.
- Letta-High.
- Wimauma-Hills.

- Island Ford-Hills.
- Placid-High.
- Buffum-Polk
- Cypress-Hills.
- Thorpe-Hills.
- Arietta-Polk
- Huntley-High.
- Silver-High.
- Ruth-High.
- Alice-Hills.
- Charlotte-High.
- Ca and Mg Bicarbonate**
- Otting-Marion
- Cooter-Citrus
- Magnolia-Citrus
- Big Gant-Sumter
- Cato-Citrus
- Hog Pond-Citrus
- Connell-Citrus
- Unnamed-Pasco
- Bystre-Hern.
- Unnamed-Hern.
- McKethan-Hern.
- Loyce-Pasco
- Round-Hills.
- Bonnett-Hern.
- Ft Cooper-Citrus
- Floral City-Citrus
- Hunters-Pasco
- Davis-Citrus
- Hampton-Citrus
- Tussock-Citrus
- Holden-Citrus
- Skinner-Hern.
- Rock Pond-Hern.
- Henderson-Citrus
- Lit. Henderson-Citrus
- Spivey-Citrus
- Van Ness-Citrus
- Mirror-Pnls.
- Todd-Citrus
- Dodd-Citrus
- Geneva-Hern.
- Granada-High.
- Consuella-Citrus
- Irvine-Hern.
- Bellamy-Citrus
- Croft-Citrus
- Lindsey-Hern.
- Hancock-Polk
- Haines-Polk
- Bellevue-Pnls.
- Sodium Bicarbonate**
- Effie-Polk

Sum of Major Ion Concentration by Lake Chemical Type

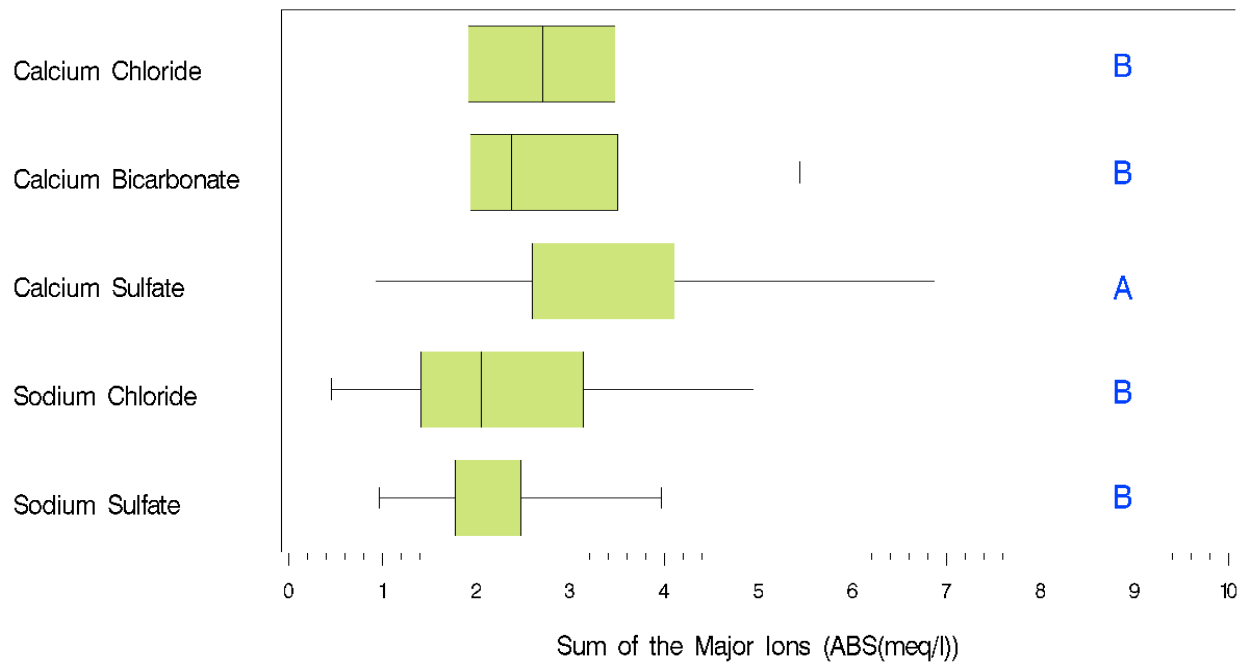

Figure 14. Bar plot of sum of the major ions (as the absolute value of the concentrations in meq/l), by lake water chemical type. Represented are the median, 25th and 75th percentiles, and the minimum and maximum values for the sample lakes (n=309). Only the five most common ionic types are shown for each group. Not shown are sodium bicarbonate lakes (2 lakes total), magnesium sulfate lakes (2 lakes total), and magnesium chloride lakes (1 lake total). There are differences in mean ranks (Mann-Whitney Test, $P < 0.05$); means with the same letter are not significantly different (Tukey's Studentized Range Test performed on the ranked values; $P < 0.05$).

pH by Lake Chemical Type

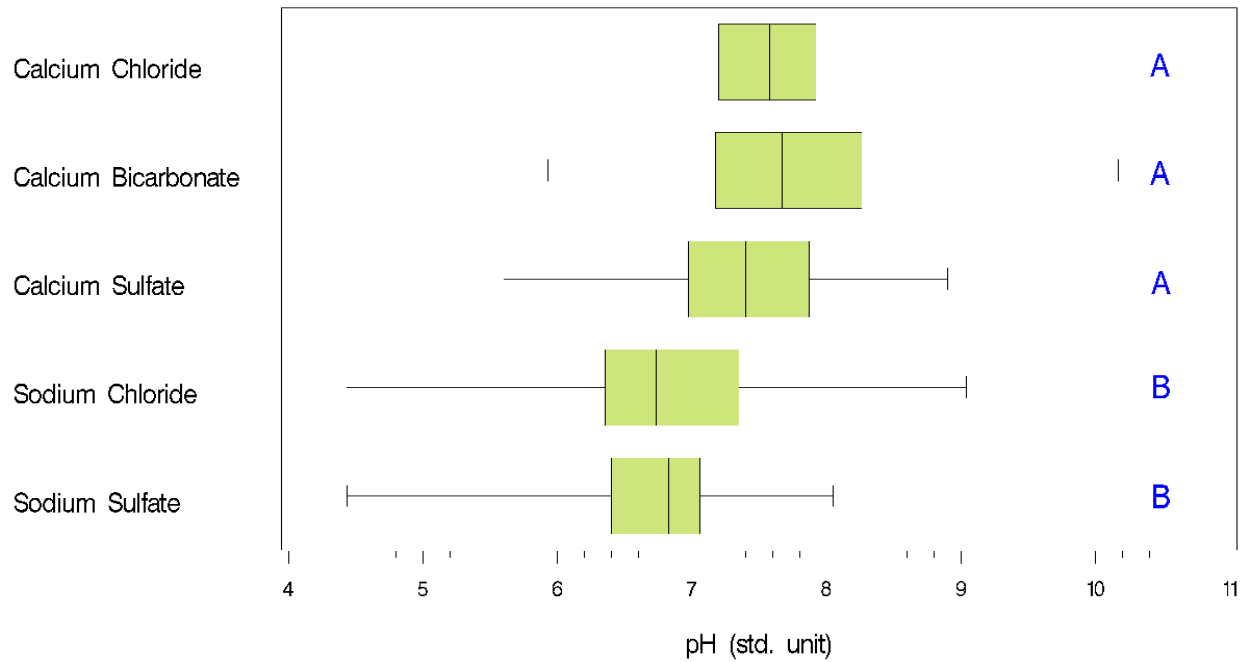
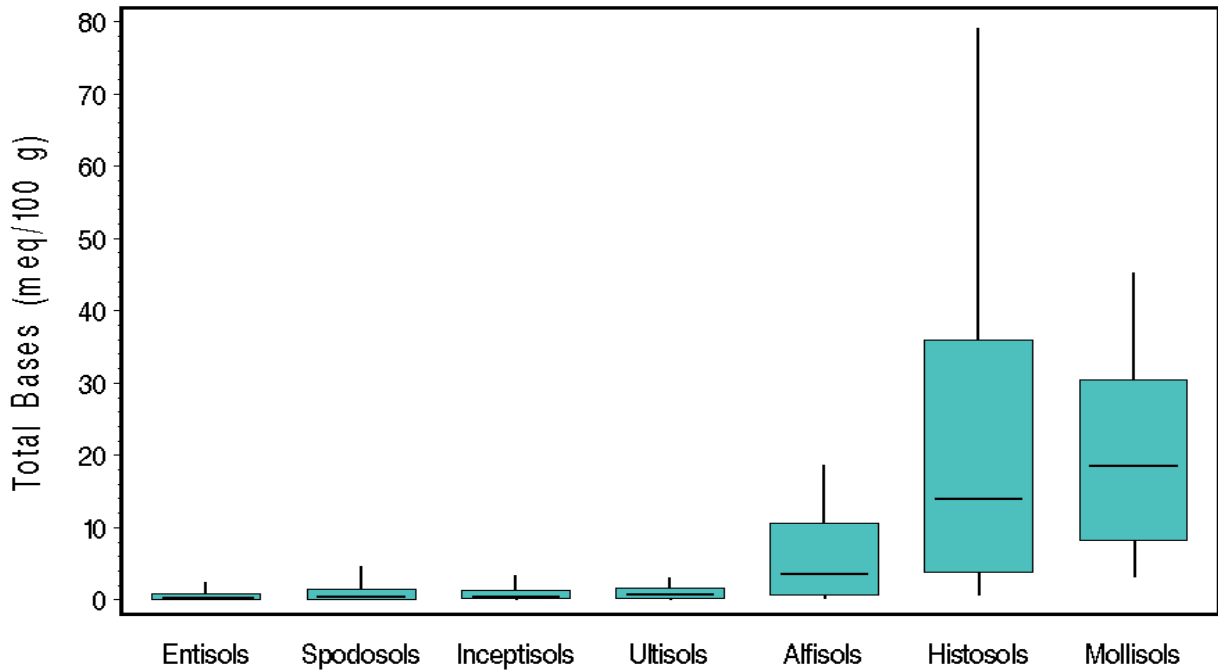

Figure 15. Bar plot of pH by lake water chemical type. Represented are the median, 25th and 75th percentiles, and the minimum and maximum values for the sample lakes (n=309). Only the five most common ionic types are shown. Not shown are sodium bicarbonate lakes (2 lakes total), magnesium sulfate lakes (2 lakes total), and magnesium chloride lakes (1 lake total). There are differences in mean ranks (Mann-Whitney Test, $P < 0.05$); means with the same letter are not significantly different (Tukey's Studentized Range Test; $P < 0.05$).

Soil Total Bases by Soil Order



Soil Cation Exchange Capacity by Soil Order

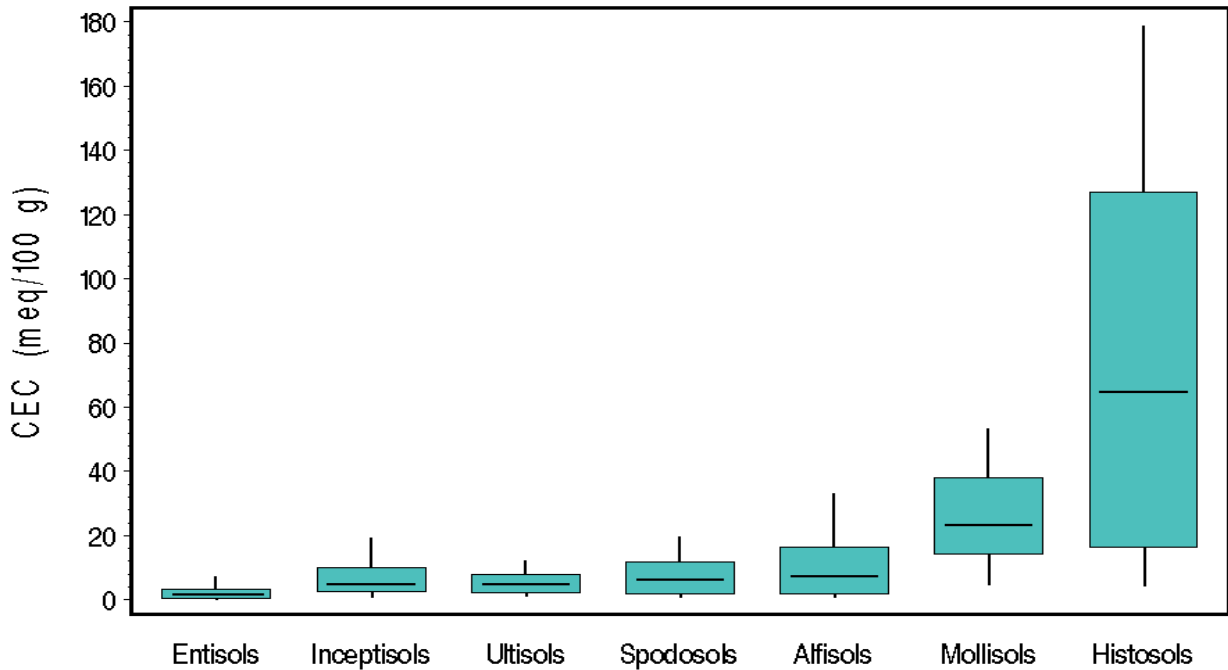
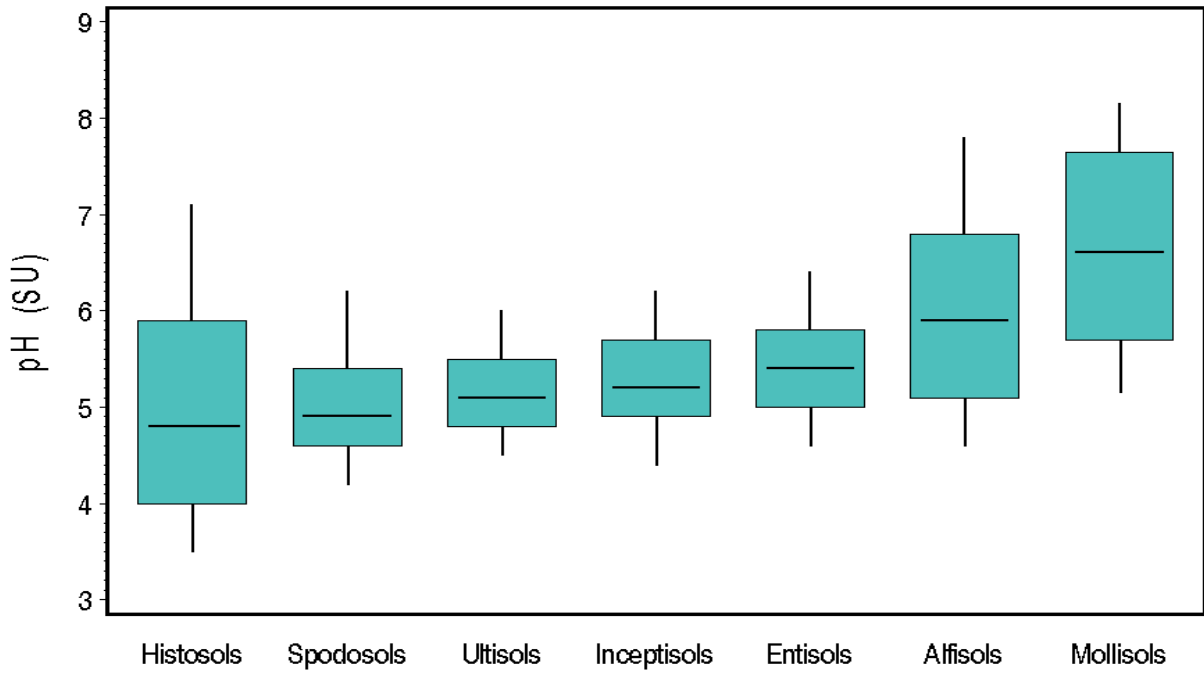

Figure 16. *top* - Soil total bases, which is the sum of the major cations (Mg, Ca, Na, K). *bottom* - Soil cation exchange capacity, which is a measure of the ability of the soil to attract and retain ions, and is dependent upon soil clay content, type of clay, and amount of soil organic material. Represented are the median, 25th and 75th percentiles, and the minimum and maximum values for the seven soil orders associated with the sampled lakes. Sample sizes varied greatly (see Table 10).

Soil pH by Soil Order



Soil Organic Carbon by Soil Order

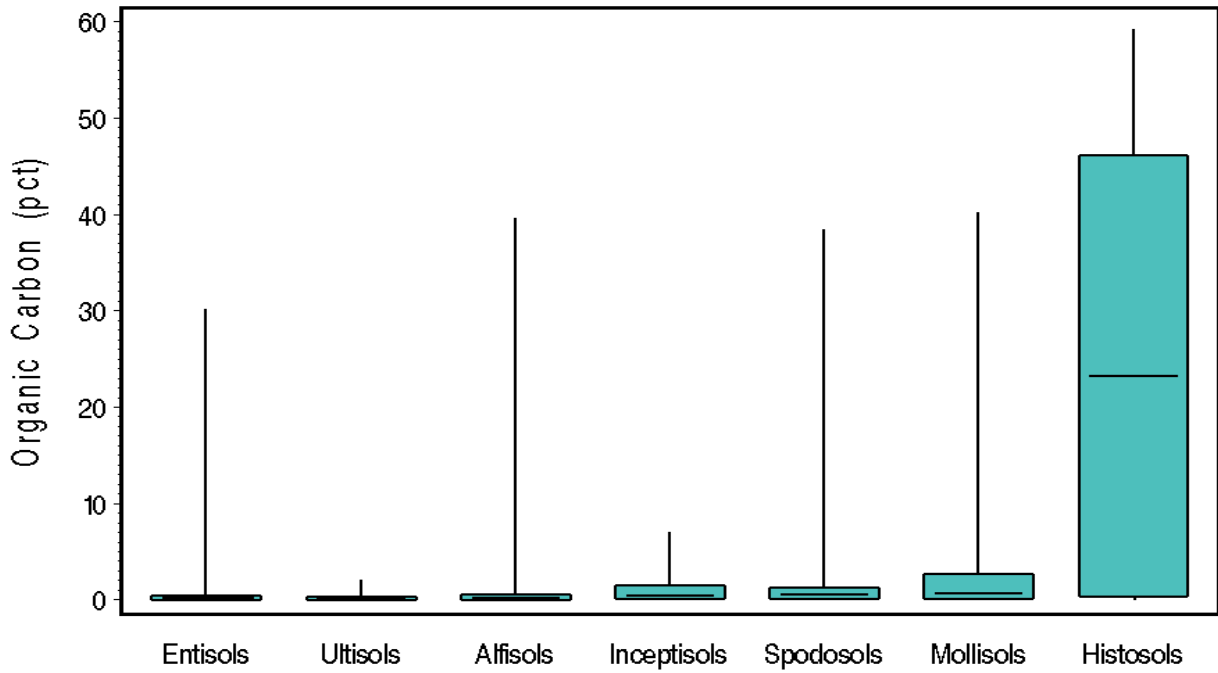
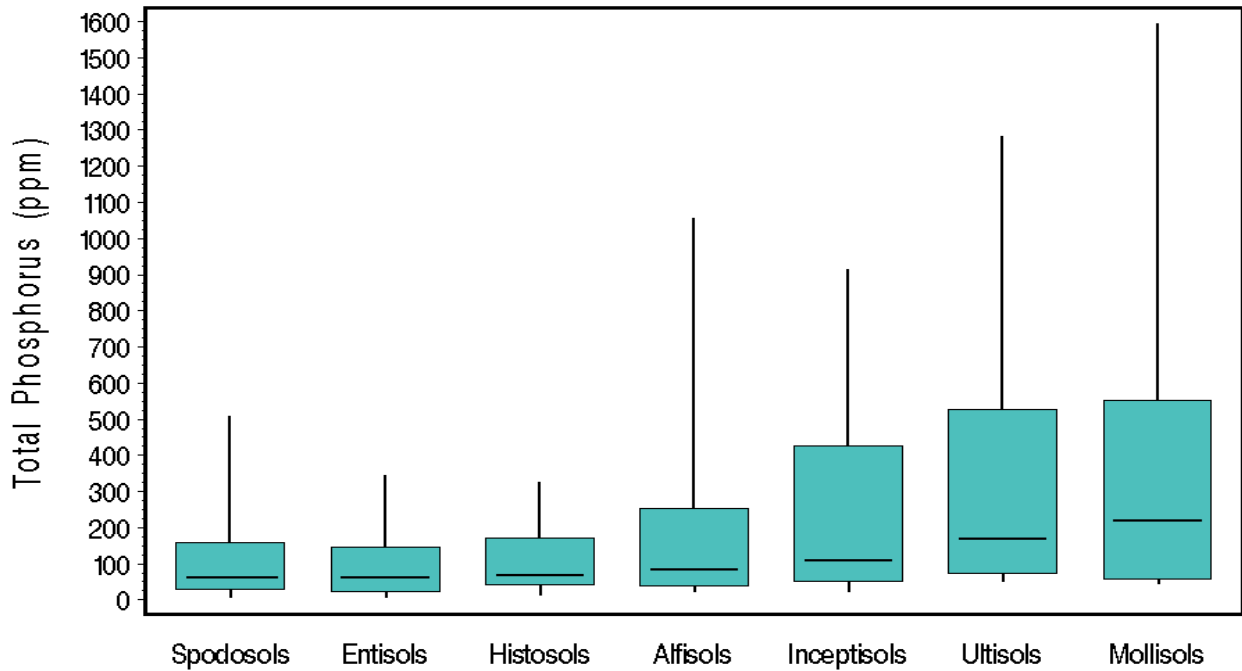

Figure 17. *top* - Soil pH by soil order. *bottom* - Soil organic carbon content. Represented are the median, 25th and 75th percentiles, and the minimum and maximum values for the seven soil orders associated with the sampled lakes. Sample sizes varied greatly (see Table 10).

Soil Total Phosphorus by Soil Order



Soil Hydraulic Conductivity by Soil Order

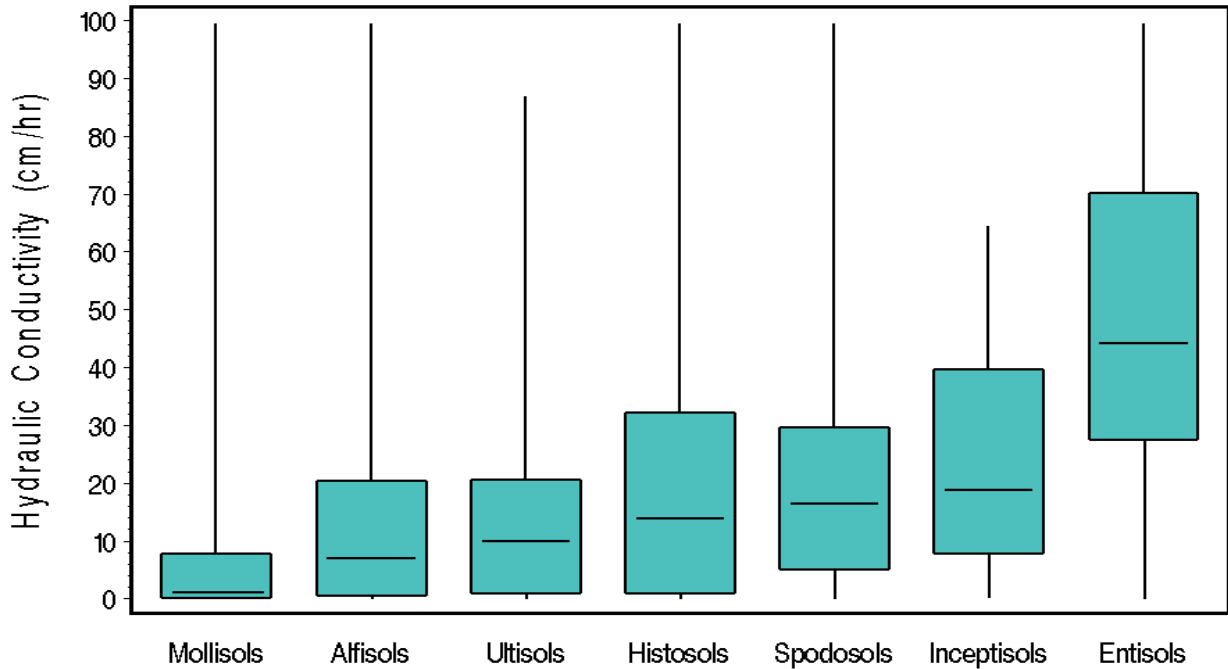
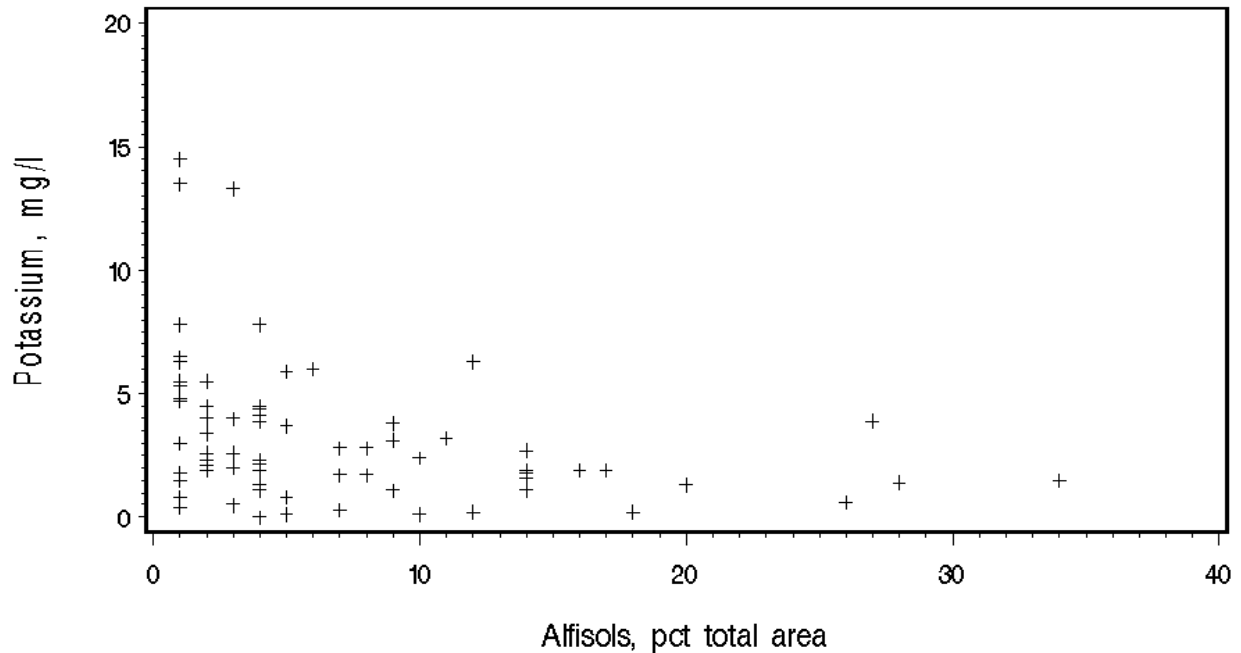

Figure 18. *top* - Soil total phosphorus by soil order, in parts per million (ppm), equivalent to mg/Kg. The plot is shown to represent the potential differences between the total P content of soils of the soil orders shown; however, different methods of sample preparation and phosphorus extraction were used for the analyses, so results may not be comparable. *bottom* - soil hydraulic conductivity, in centimeters per hour. Maximums are not shown for five of the orders to better show the interquartile ranges and median values; they are Mollisols (max=407), Alfisols (max=405), Histosols (max=636), Spodosols (max=139), and Entisols (max=256). Sample size varied greatly (Table 10).

Potassium by Alfisol Soil Order



Potassium by Alfisol Soil Order (Ranks)

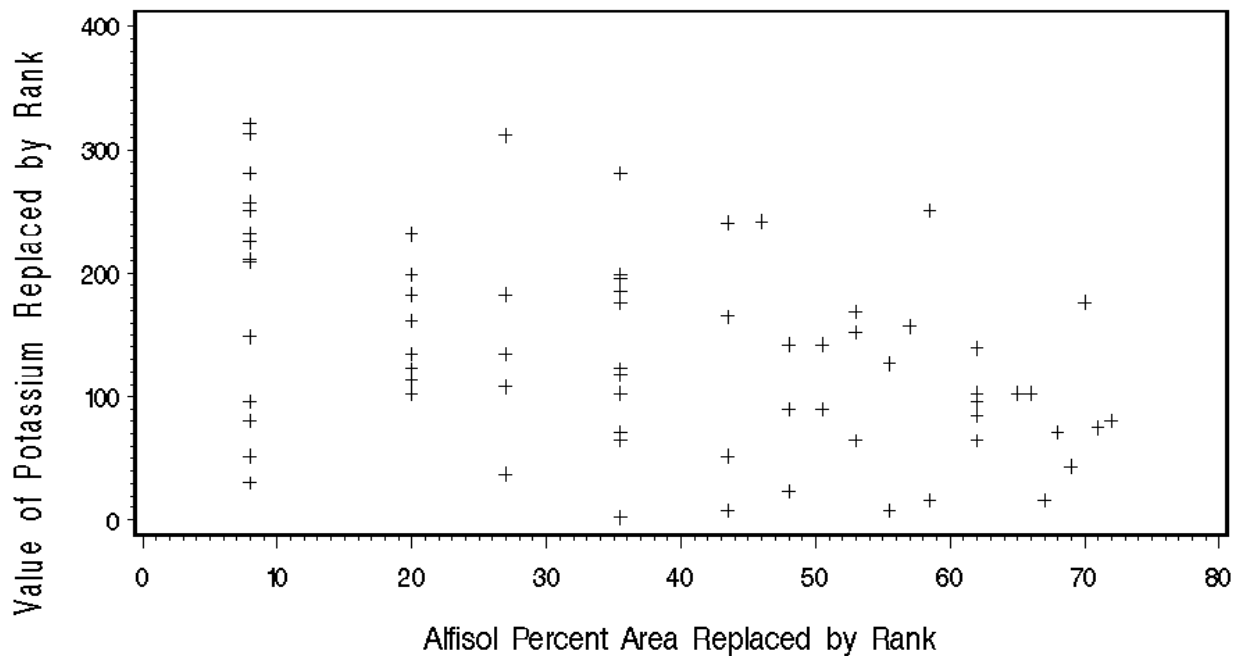
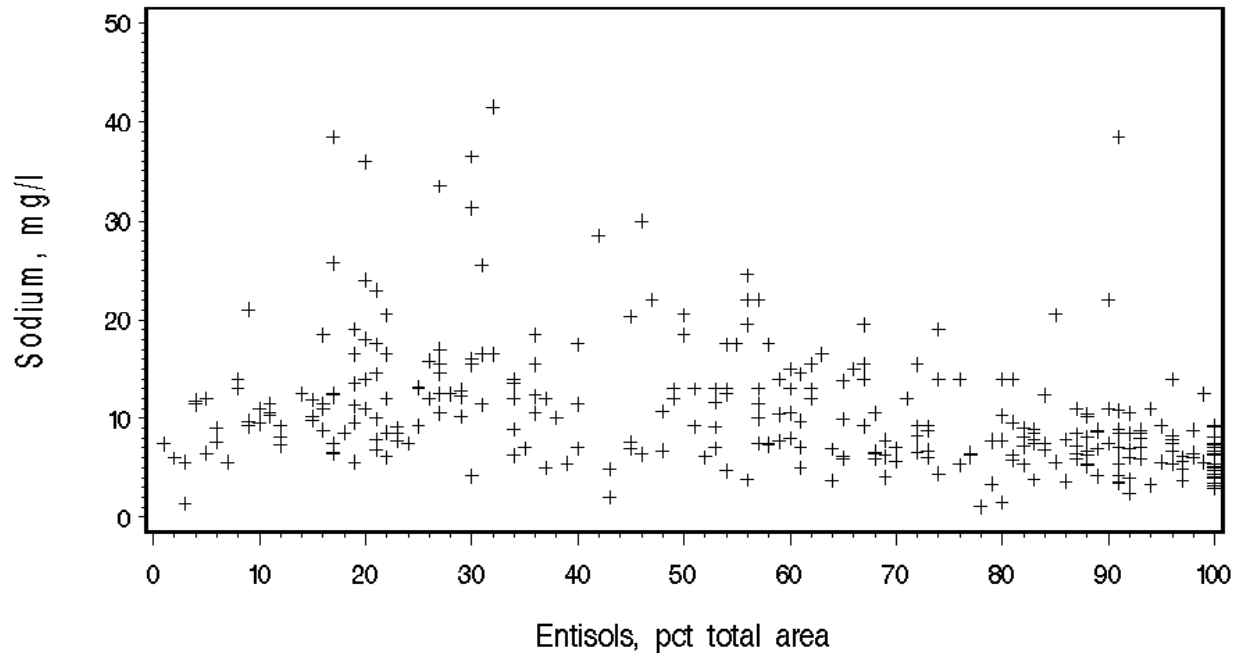

Figure 19. Plots of potassium by Alfisol soil order. The top plot is of raw values, the lower plot is of the ranked values of both potassium and Alfisol area. 'Area' is percent of a 500 meter buffer area surrounding each lake, and is assumed to represent soils typical of the watershed. If there were no Alfisols in the area, then data were considered missing for that observation; thus, ranks are for only 72 lakes rather than for the total population of lakes (323 lakes total).

Sodium by Entisol Soil Order



Sodium by Entisol Soil Order (Ranks)

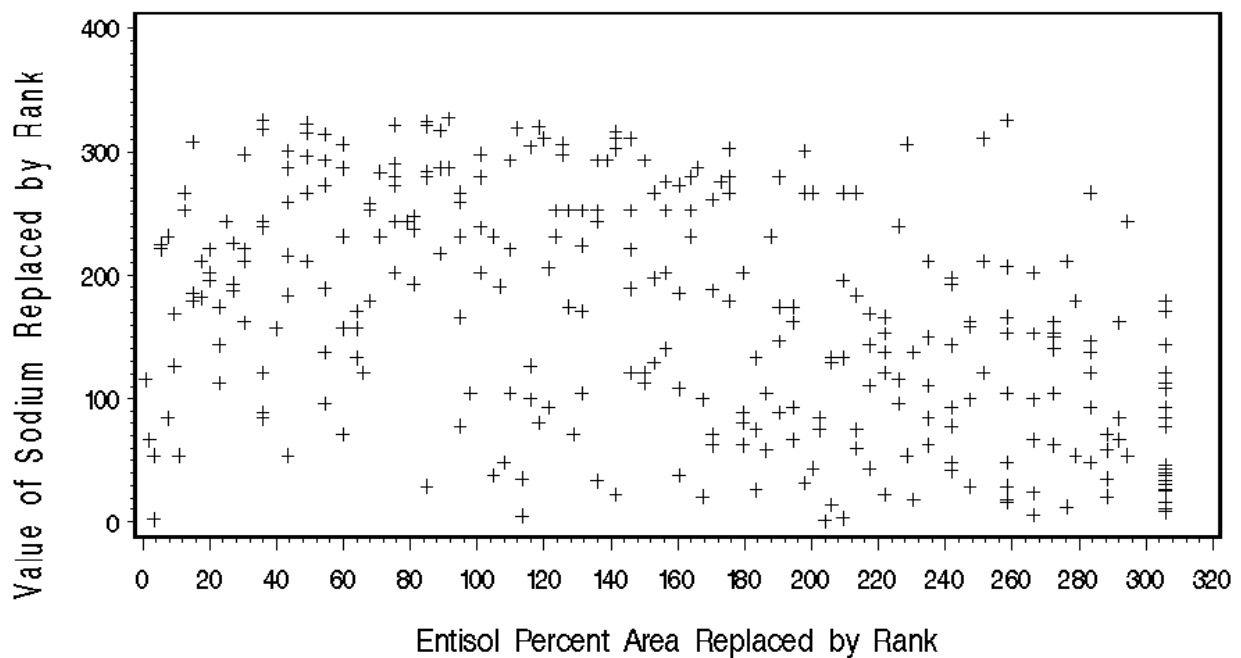
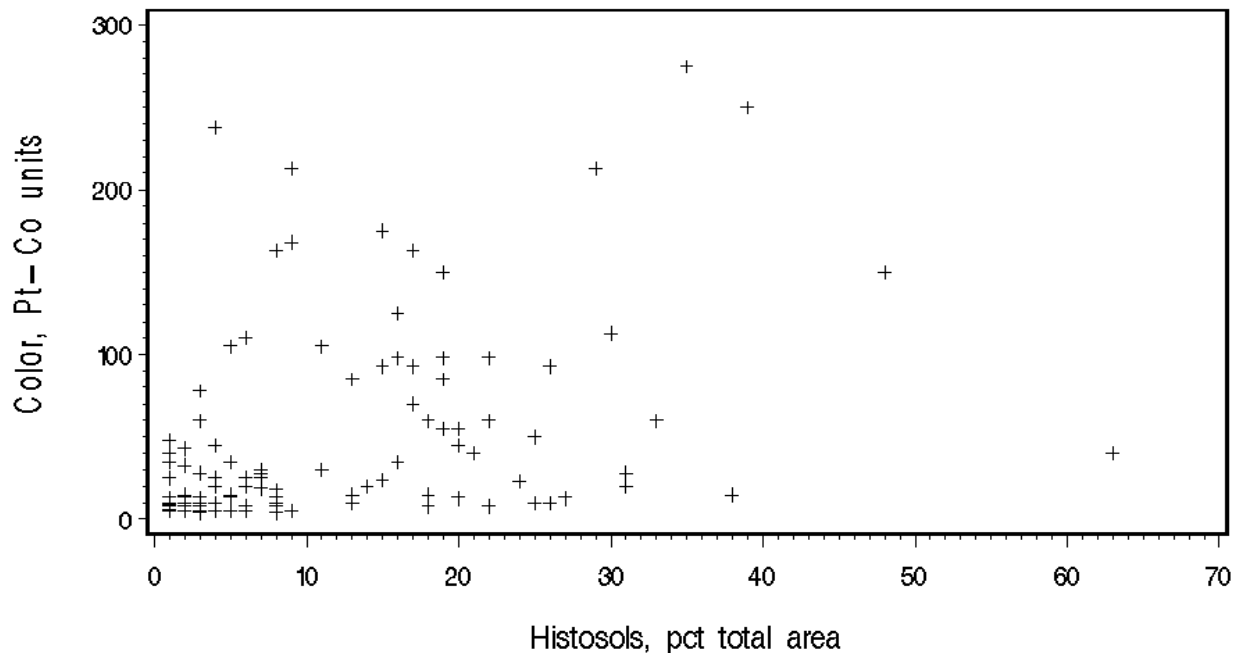

Figure 20. Plots of sodium by Entisol soil order. The top plot is of raw values, the lower plot is of the ranked values of both sodium and Entisol area. 'Area' is percent of a 500 meter buffer area surrounding each lake, and is assumed to represent soils typical of the watershed. If there were no Entisols in the area, then data were considered missing for that observation; thus, ranks are for only 316 lakes rather than for the total population of lakes (323 lakes total).

Color By Histosol Soil Order



Color by Histosol Soil Order (Ranks)

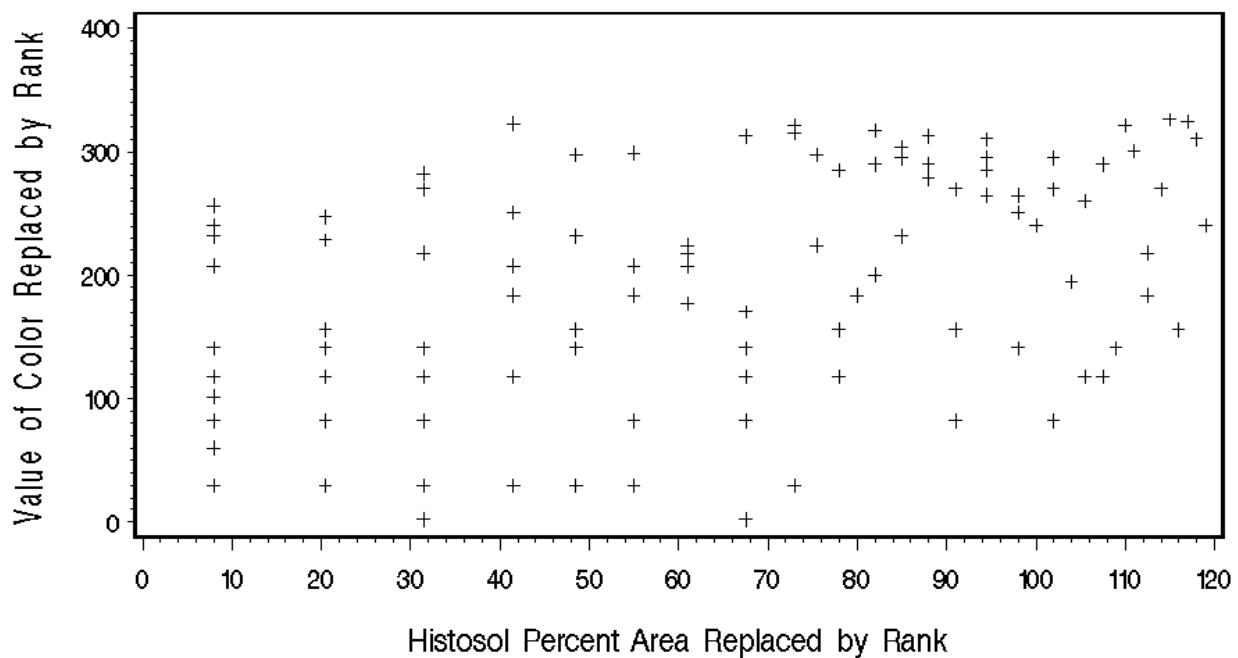
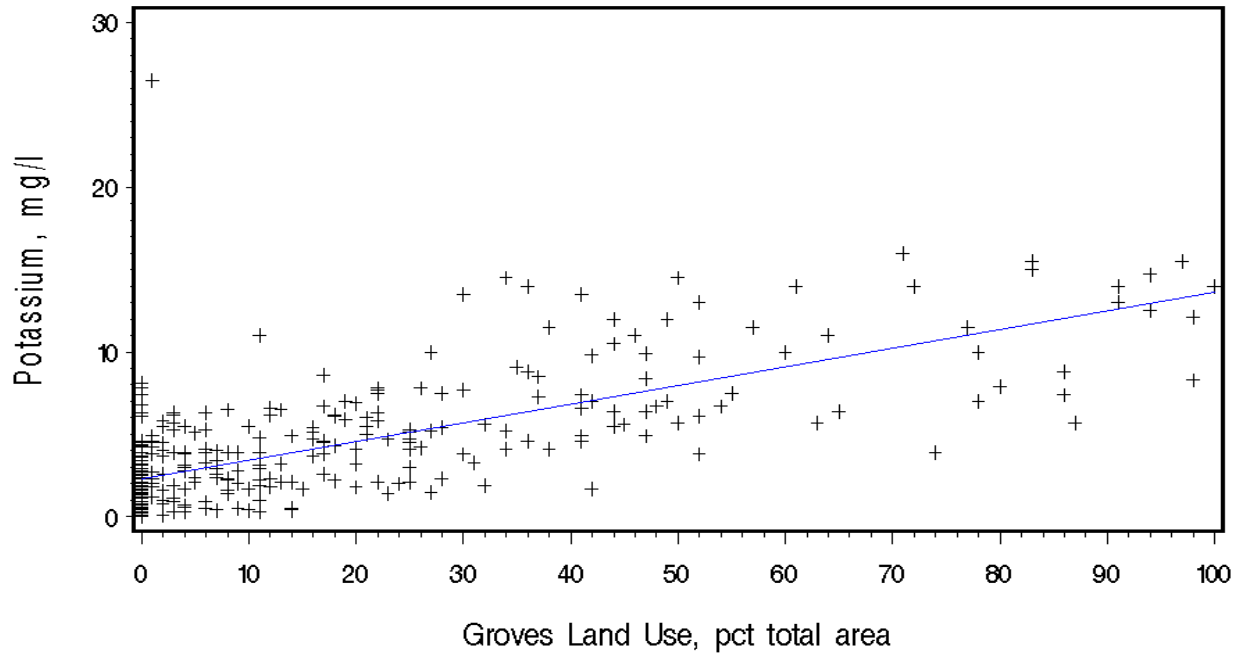

Figure 21. Plots of color by Histosol soil order. The top plot is of raw values, the lower plot is of the ranked values of both color and Histosol area. 'Area' is percent of a 500 meter buffer area surrounding each lake, and is assumed to represent soils typical of the watershed. If there were no Histosols in the area, then data were considered missing for that observation; thus, ranks are for only 119 lakes rather than for the total population of lakes (323 lakes total).

Potassium by Groves Land Use



Magnesium by Groves Land Use

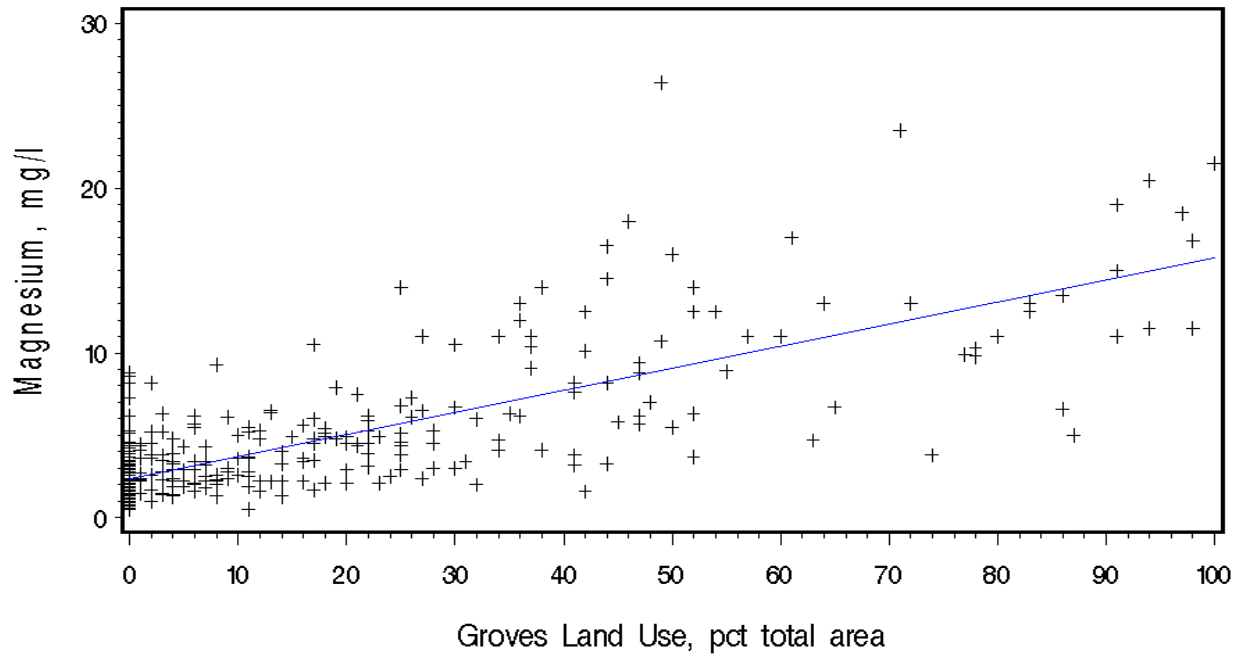
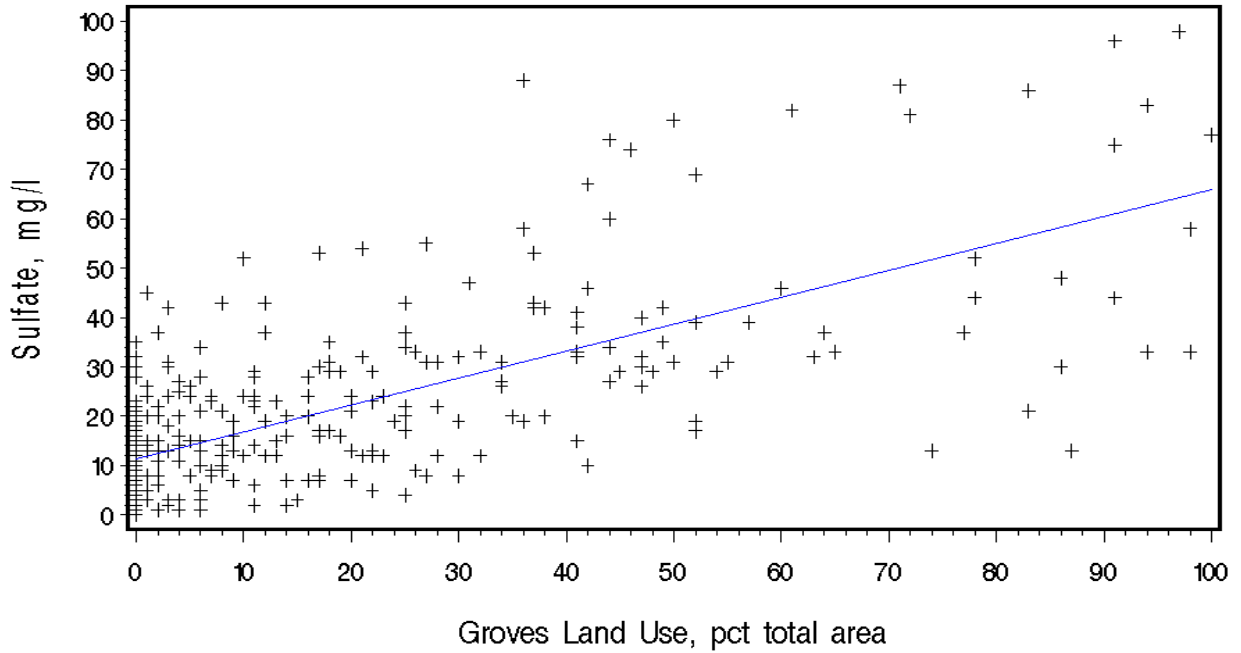

Figure 22. Plots of potassium and magnesium by grove type land use. The regression line shown on the plots show the suggested relationships, however, the data for grove land use percent area and for water chemistry were not normally distributed which violates the normality assumption of regression statistics. The regression line is not significant.

Sulfate by Groves Land Use



Total Hardness by Groves Land Use

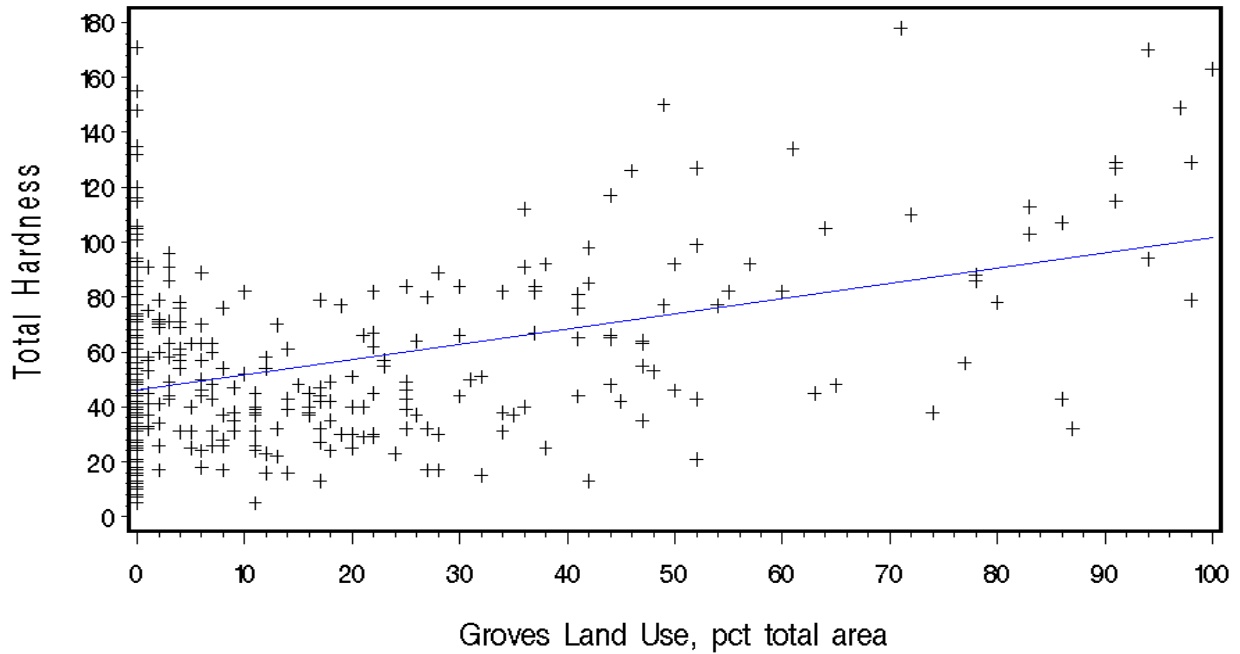
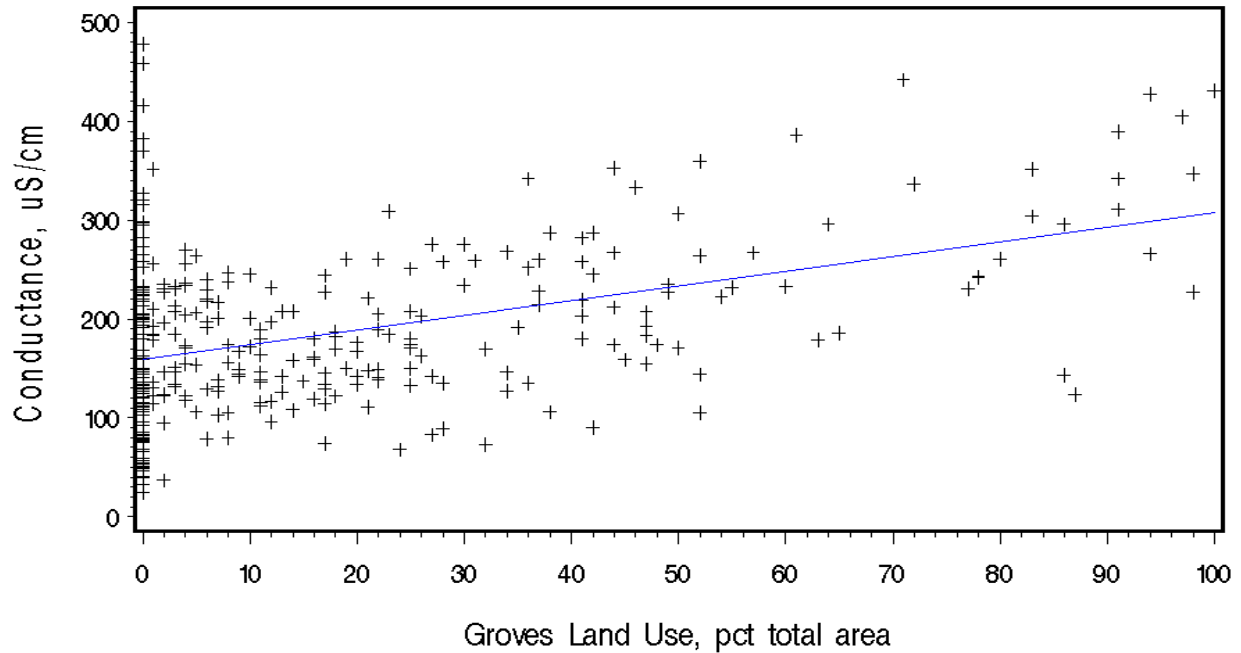

Figure 23. Plots of sulfate and total hardness by grove type land use. The regression line shown on the plots show the suggested relationships, however, the data for grove land use percent area and for water chemistry were not normally distributed which violates the normality assumption of regression statistics. The regression line is not significant.

Conductance by Groves Land Use



Nitrate by Groves Land Use

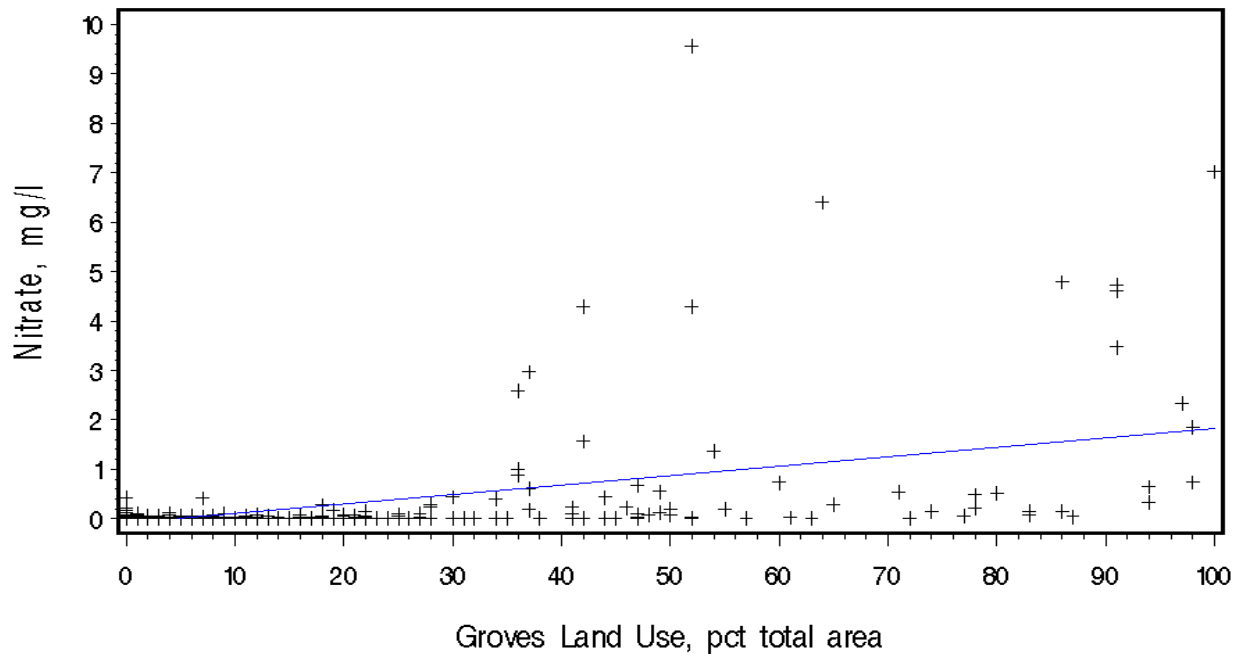

Figure 24. Plots of specific conductance and nitrate by grove type land use. The regression line shown on the plots show the suggested relationships, however, the data for grove land use percent area and for water chemistry were not normally distributed which violates the normality assumption of regression statistics. The regression line is not significant.

Nitrate by Grove Land Use and Entisol Soil Order

size of bubble is proportional to concentration

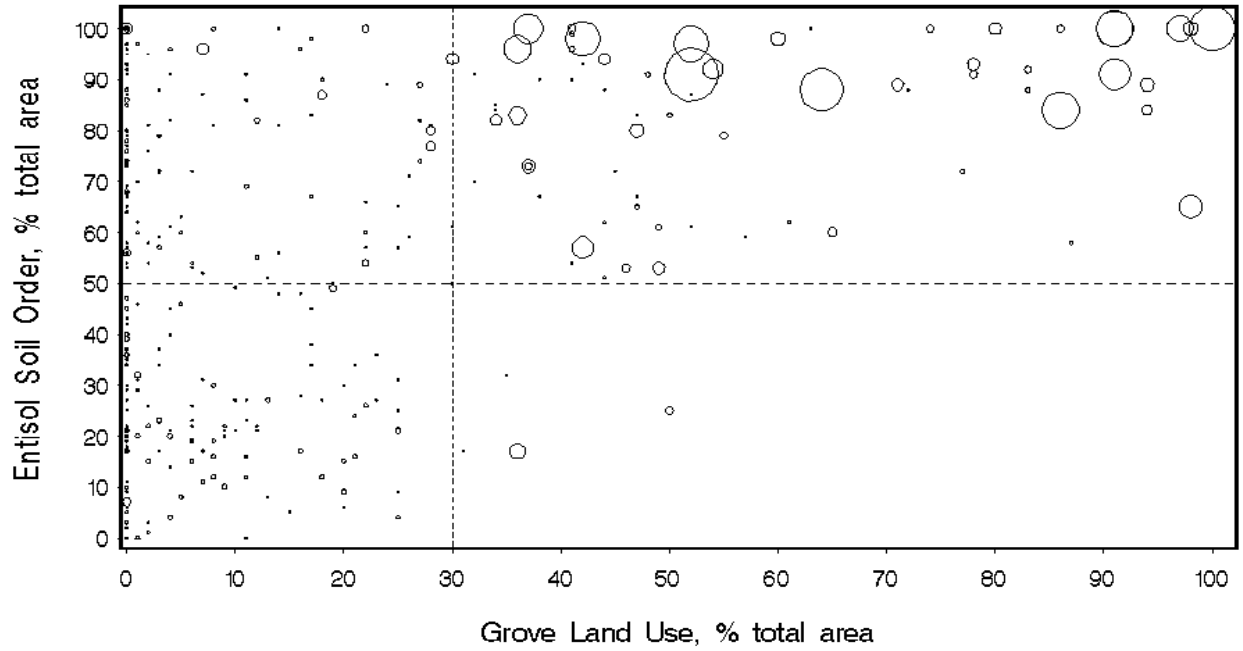
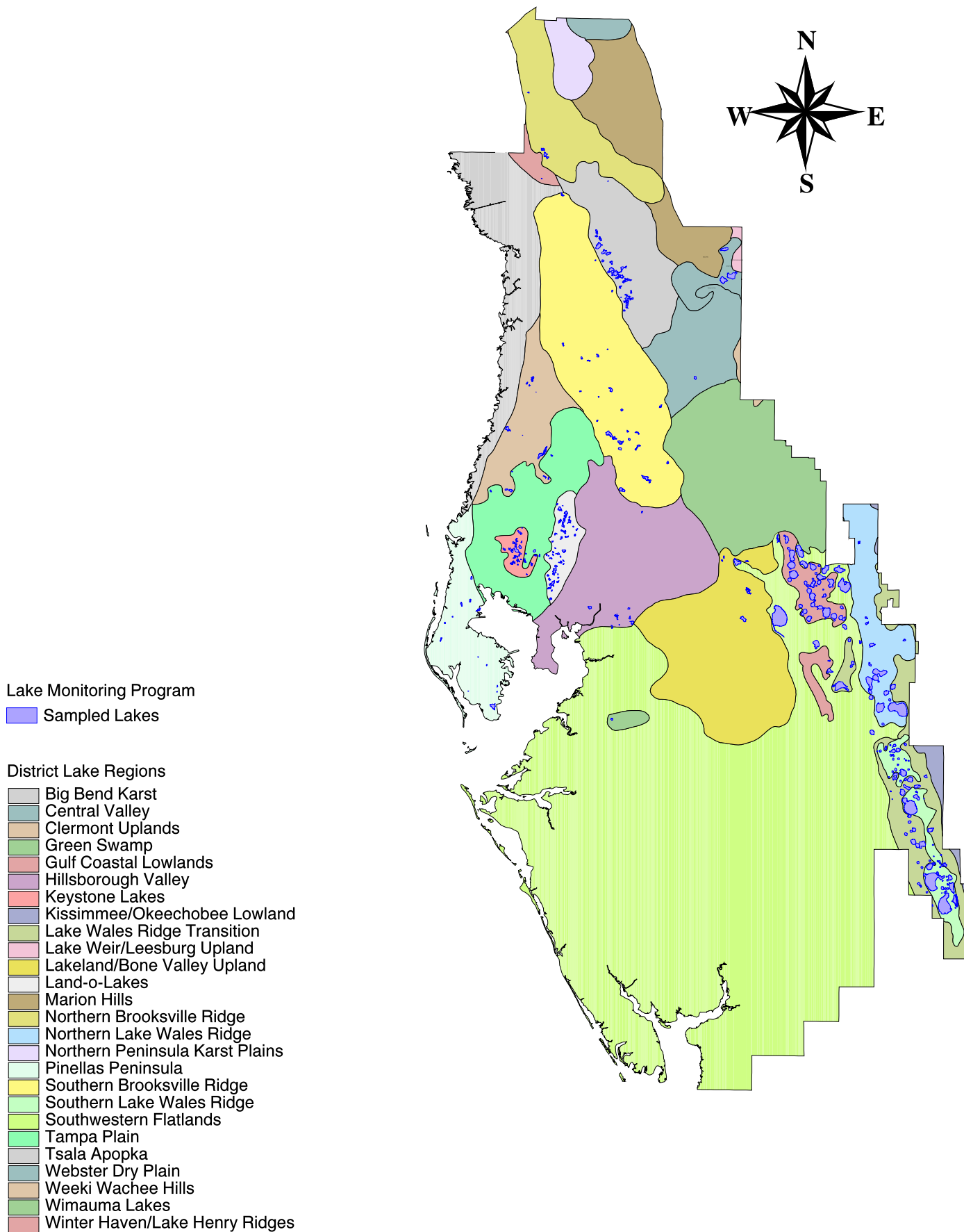

Figure 25. Bubble plot depicting the relationship between grove land use and Entisol soil order on sample lake nitrate concentrations. The relative size (area) of the 'bubble' is proportional to the concentration of nitrate.

Figure 26. Florida Lake Regions in the Southwest Florida Water Management District, from Griffith et al., 1997, "Lake Regions of Florida". Approx. scale 1 inch=25 miles.



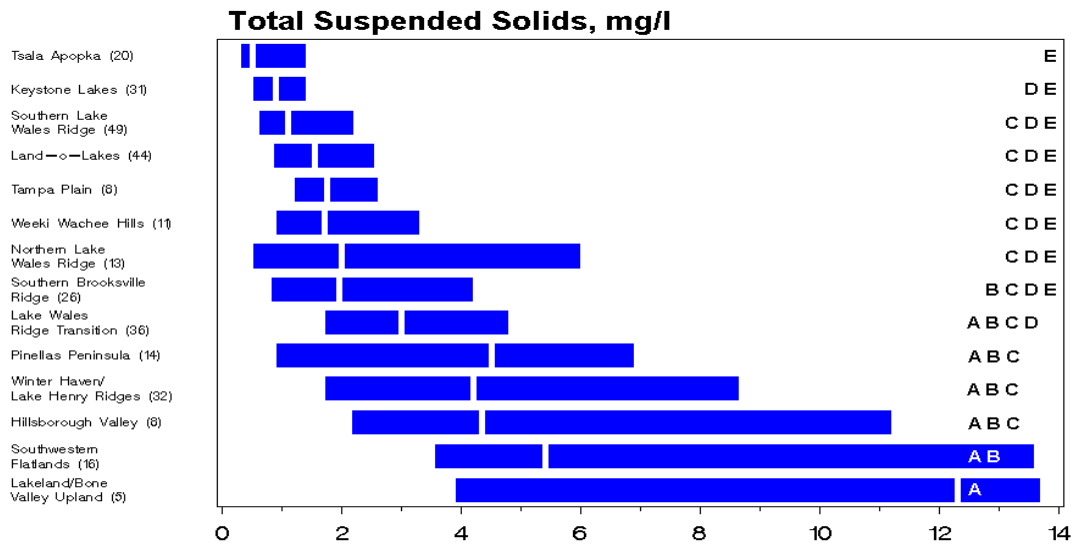
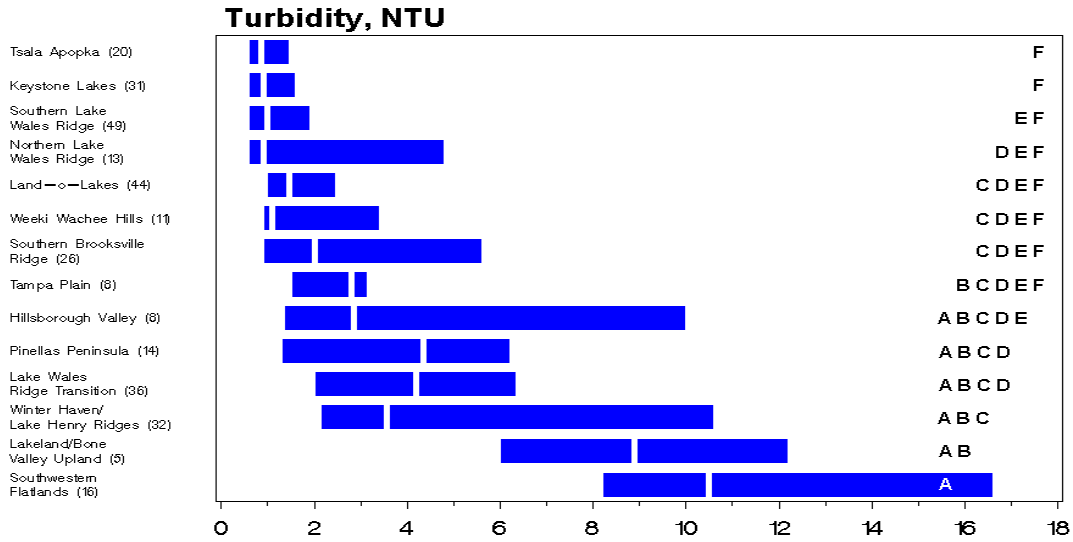

Figure 27. Box plots of turbidity and total suspended solids, vs. Florida Lake Region (Griffith *et al.* 1997). The blue bars represent the interquartile range (25th to 75th percentile range); the white bar represents the median value for lakes within the lake region. Letters to the right of the plot are the results of Tukey's studentized range test performed on the ranked median values for sampled lakes, means with letters in common are not significantly different ($P < 0.05$).

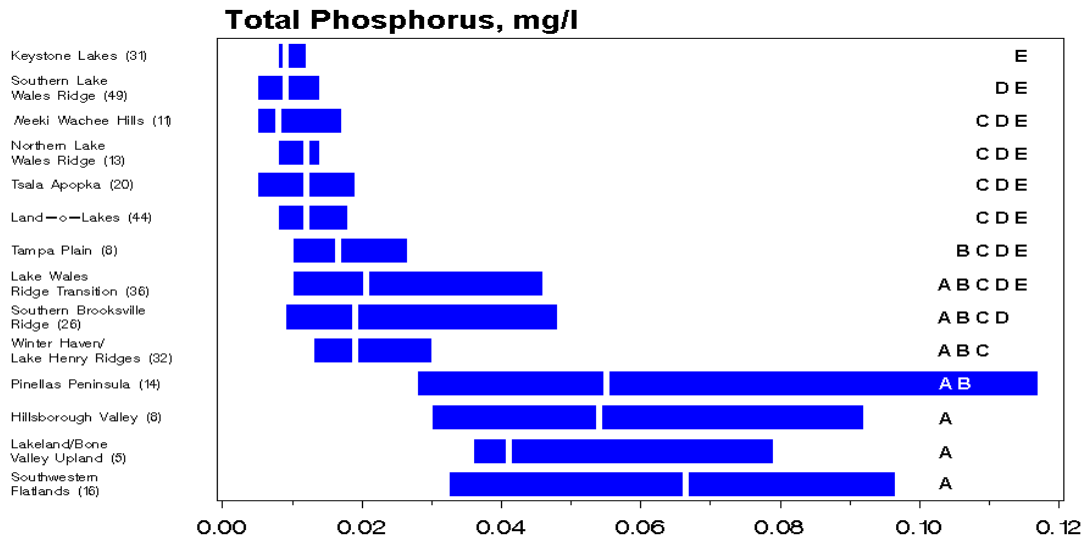
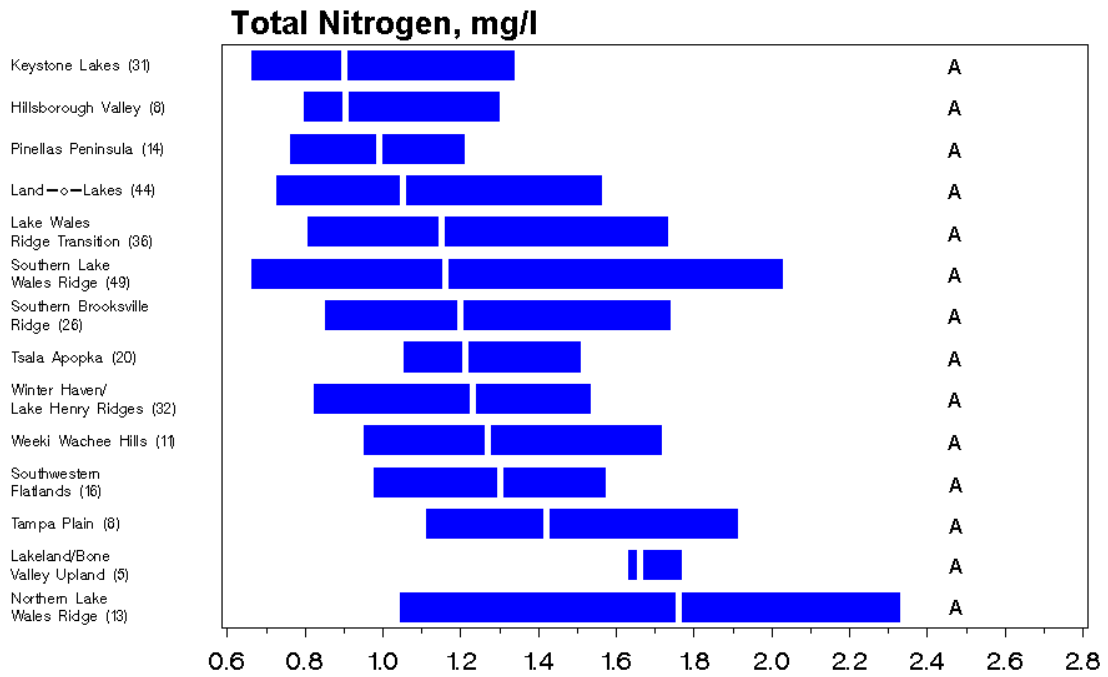

Figure 28. Box plots of total nitrogen and total phosphorus, vs. Florida Lake Region (Griffith *et al.* 1997). The blue bars represent the interquartile range (25th to 75th percentile range); the white bar represents the median value for lakes within the lake region. Letters to the right of the plot are the results of Tukey's studentized range test performed on the ranked median values for sampled lakes, means with letters in common are not significantly different ($P < 0.05$).

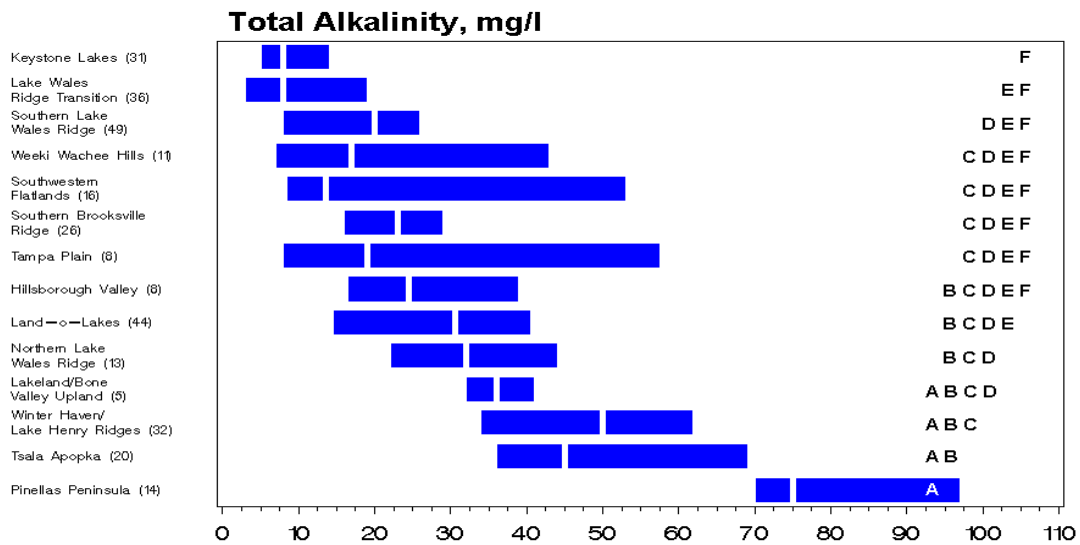
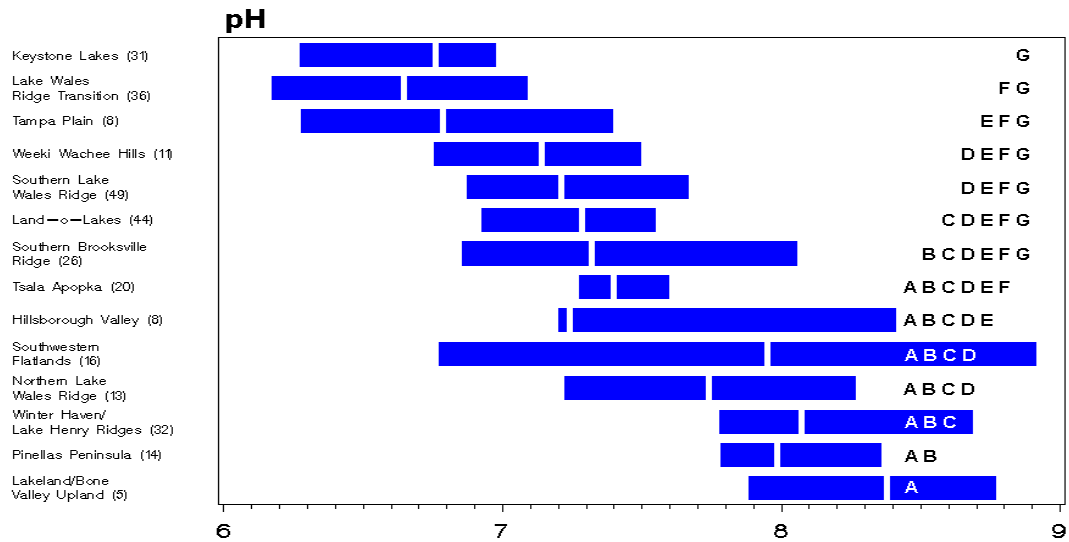

Figure 29. Box plots of pH and total alkalinity, vs. Florida Lake Region (Griffith *et al.* 1997). The blue bars represent the interquartile range (25th to 75th percentile range); the white bar represents the median value for lakes within the lake region. Letters to the right of the plot are the results of Tukey's studentized range test performed on the ranked median values for sampled lakes, means with letters in common are not significantly different ($P < 0.05$).

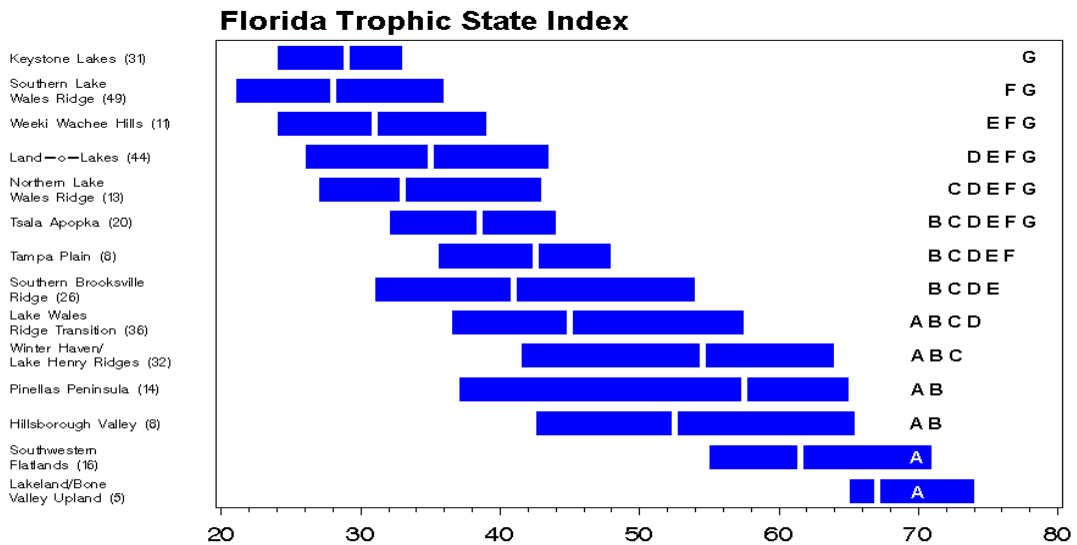
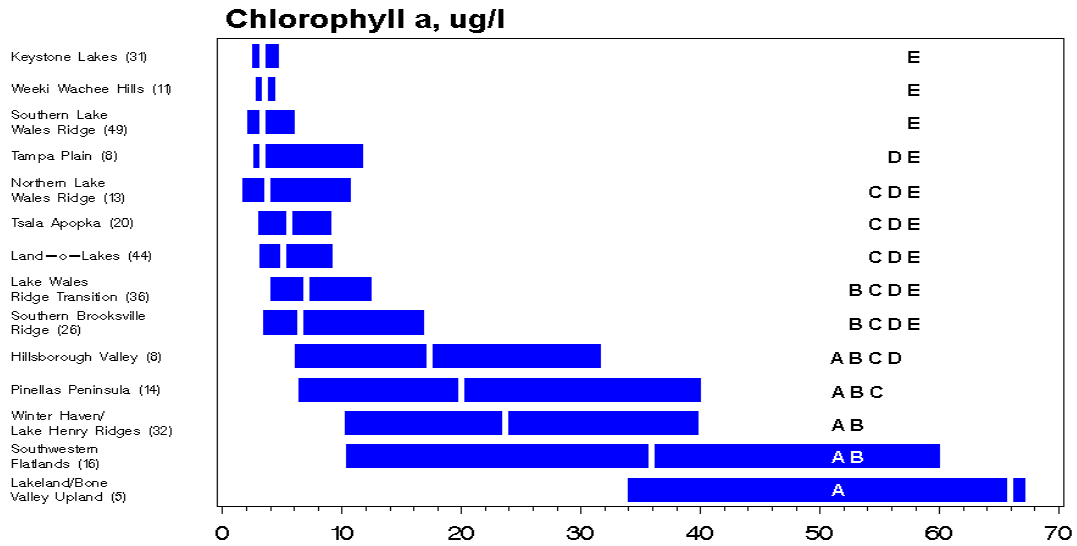

Figure 30. Box plots of chlorophyll *a* and Florida trophic state index, vs. Florida Lake Region (Griffith *et al.* 1997). The blue bars represent the interquartile range (25th to 75th percentile range); the white bar represents the median value for lakes within the lake region. Letters to the right of the plot are the results of Tukey's studentized range test performed on the ranked median values for sampled lakes, means with letters in common are not significantly different ($P < 0.05$).

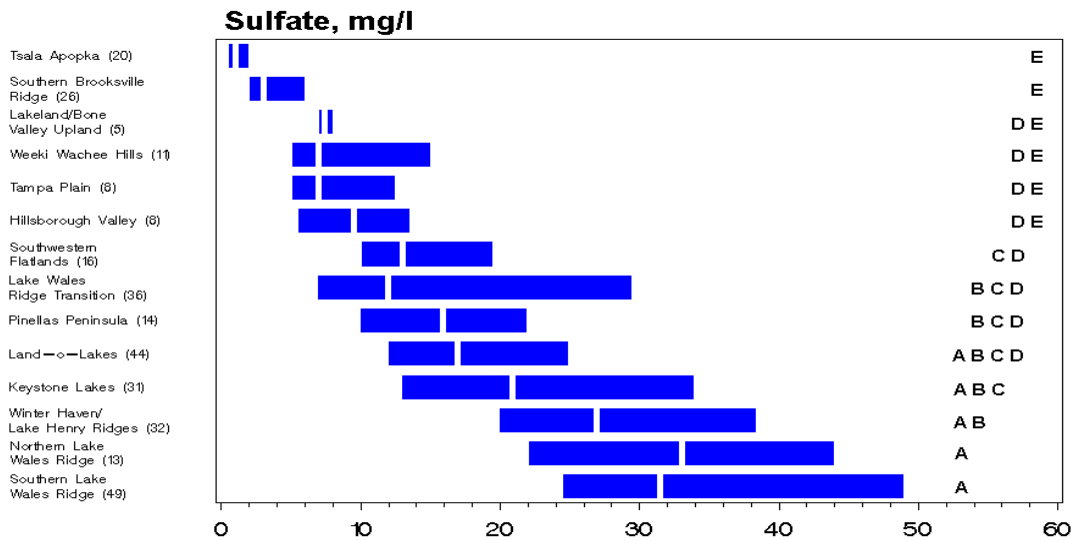
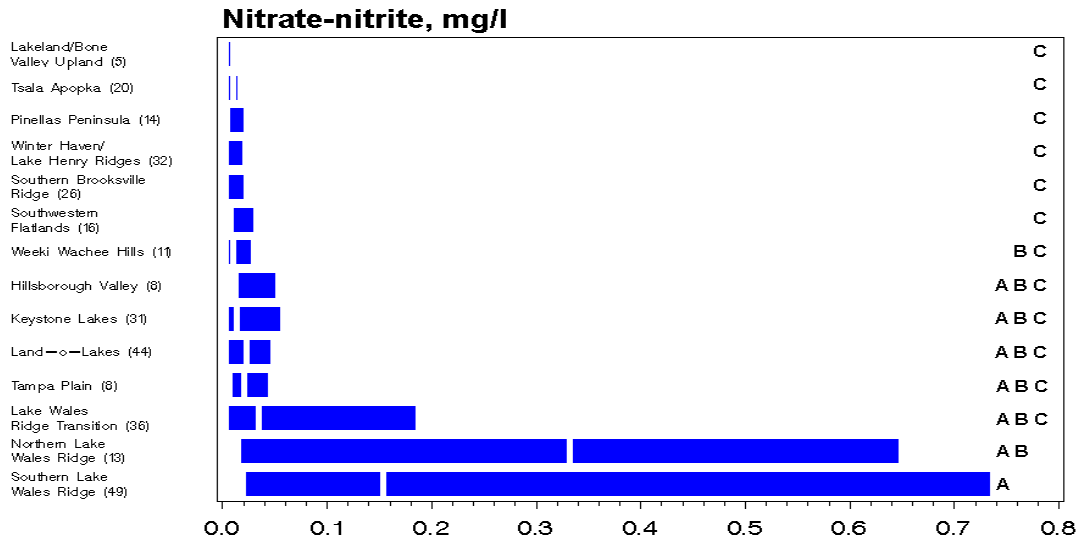
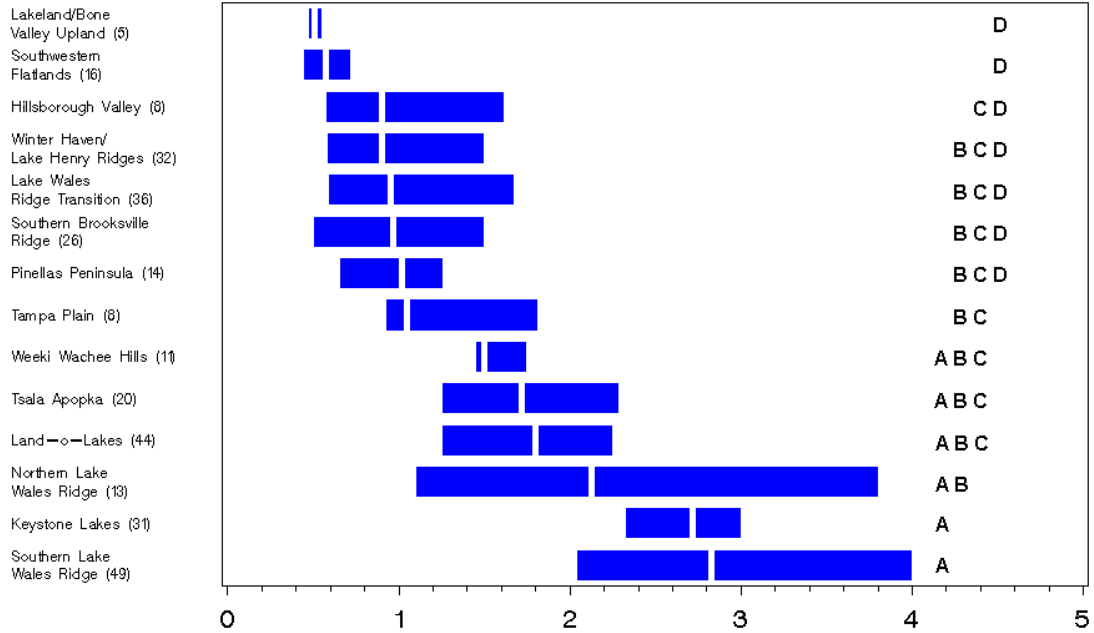

Figure 31. Box plots of nitrate and sulfate, vs. Florida Lake Region (Griffith *et al.* 1997). The blue bars represent the interquartile range (25th to 75th percentile range); the white bar represents the median value for lakes within the lake region. Letters to the right of the plot are the results of Tukey's studentized range test performed on the ranked median values for sampled lakes, means with letters in common are not significantly different ($P < 0.05$).

Secchi Depth, meters



Conductivity, uS/cm

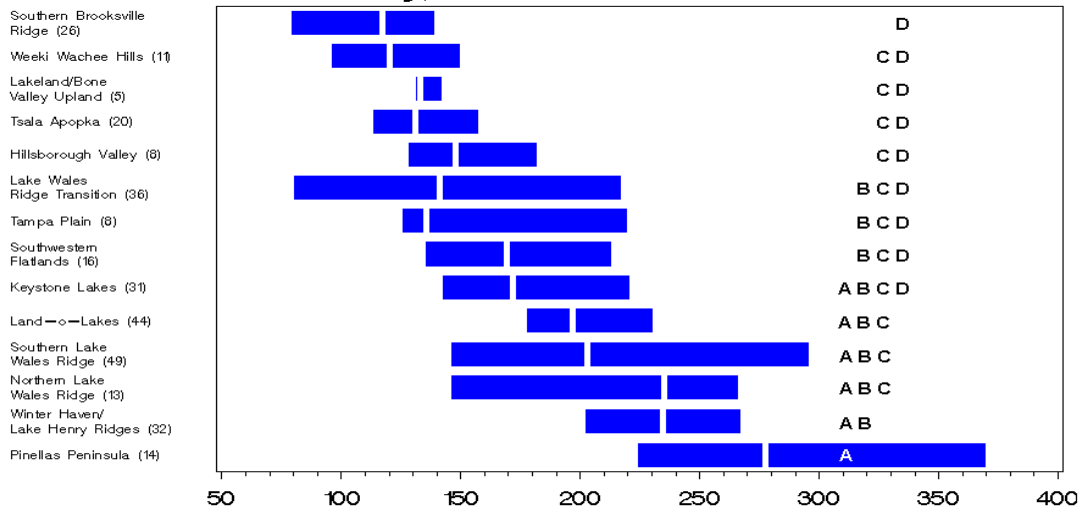

Figure 32. Box plots of conductivity and Secchi depth vs. Florida Lake Region (Griffith *et al.* 1997). The blue bars represent the interquartile range (25th to 75th percentile range); the white bar represents the median value for lakes within the lake region. Letters to the right of the plot are the results of Tukey's studentized range test performed on the ranked median values for sampled lakes, means with letters in common are not significantly different ($P < 0.05$).

Literature Cited

- American Public Health Association. 1992. Standard Methods for the Examination of Water and Wastewater, 18th ed., American Public Health Association. Washington, D.C.
- Calhoun, F.G., V.W. Carlisle, R.E. Caldwell, L.W. Zelazny, L.C. Hammond, and H.L. Breland. 1974. Characterization Data for Selected Florida Soils. Soil Science research Report No. 74-1. Soil Science Dept., Soil Characterization Laboratory, University of Florida Institute of Food and Agricultural Sciences, Gainesville, Florida.
- Canfield, D.E., Jr. 1981. Chemical and Trophic State Characterizations of Florida Lakes. University of Florida Institute of Food and Agricultural Sciences, Gainesville, Florida.
- Carlisle, V.W., R.B. Brown. 1982. Florida Soil Identification Handbook. Soil Science Dept., University of Florida Institute of Food and Agricultural Sciences, Gainesville, Florida. 186 pp.
- Carlisle, V.W., F. Sodek III, M.E. Collins, L.C. Hammond, and W.G. Harris. 1988. Characterization Data for Selected Florida Soils. Soil Science research Report No. 88-1. Soil Science Dept., Soil Characterization Laboratory, University of Florida Institute of Food and Agricultural Sciences, Gainesville, Florida.
- Carlisle, V.W., M.E. Collins, F. Sodek III, and L.C. Hammond. 1985. Characterization Data for Selected Florida Soils. Soil Science research Report No. 85-1. Soil Science Dept., Soil Characterization Laboratory, University of Florida Institute of Food and Agricultural Sciences, Gainesville, Florida.
- Carlisle, V.W., C.T. Hallmark, F. Sodek III, R.E. Caldwell, L.C. Hammond, and V.E. Berkheiser. 1981. Characterization Data for Selected Florida Soils. Soil Science research Report No. 81-1. Soil Science Dept., Soil Characterization Laboratory, University of Florida Institute of Food and Agricultural Sciences, Gainesville, Florida.
- Carlisle, V.W., R.E. Caldwell, F. Sodek III, L.C. Hammond, F.G. Calhoun, M.A. Granger, and H.L. Breland. 1978. Characterization Data for Selected Florida Soils. Soil Science research Report No. 78-1. Soil Science Dept., Soil Characterization Laboratory, University of Florida Institute of Food and Agricultural Sciences, Gainesville, Florida.
- Friedemann, M., and J. Hand. 1989. Typical Water Quality Values for Florida's Lakes, Streams and Estuaries. Standards and Monitoring Section, Bureau of Surface Water Management, Florida Department of Environmental Regulation, Tallahassee, Florida.
- Gant, R.D.. 1995. Directory of Lakes within the Southwest Florida Water Management District. Southwest Florida Water Management District, Brooksville, Florida.

- Griffith, G.E., D.E. Canfield, C.A. Horsburgh, J.M. Omernik. 1997. Lake Regions of Florida. EPA/R-97/127, U.S. Environmental Protection Agency, western Ecology Division, Corvallis, Oregon. 89 pp.
- Hatcher, L., and E.J. Stepanski. 1994. A Step-by-Step Approach to Using the SAS System for Univariate and Multivariate Statistics. SAS Institute, Inc., Cary, North Carolina. 552 pp.
- Hillsborough County. 1999. Hillsborough County Lake Atlas [Online]. Available: <http://www.lakeatlas.usf.edu/> [accessed: October 26, 1999].
- Huber, W.C., P.L. Brezonik, J.P. Heaney, R.E. Dickinson, S.D. Preston, D.S. Dwornik, and M.A. DeMaio. 1982. A Classification of Florida Lakes. Publication No. 72, Water Resources Research Center, University of Florida, Gainesville.
- Hutchinson, G.E. 1957. A Treatise on Limnology. Volume I, Part 2 – Chemistry of Lakes. Wiley - Interscience, John Wiley & Sons, New York. 474 pp.
- Medani, M., and J. King. 1998. Polk County 1998 Annual Lake and Stream Report. Water Resources Section, Polk County Natural Resources and Drainage Division, Bartow, Florida.
- Southwest Florida Water Management District. 1996. Comprehensive Quality Assurance Plan for Southwest Florida Water Management District, Revision No. 6, September 3, 1996. Southwest Florida Water Management District, Brooksville, Florida.
- Southwest Florida Water Management District. 1994. First Biennial Report of the Ambient Monitoring Program, including a report on: Water Quality Trends in Five Central Florida Springs. Southwest Florida Water Management District, Brooksville, Florida.
- Southwest Florida Water Management District. 1991. Comprehensive Quality Assurance Plan for Southwest Florida Water Management District, Revision No. 2, December 1, 1991. Southwest Florida Water Management District, Brooksville, Florida.
- U.S. Environmental Protection Agency. 1983. Methods for Chemical Analysis of Water and Wastes - revised March 1983. Publ. # EPA-600/4-79-020 (Rev. Mar. 1983). Environmental Monitoring and Support Laboratory, U.S. Environmental Protection Agency, Cincinnati, Ohio.
- University of Florida. 1998. Florida Lakewatch Data 1998. Department of Fisheries and Aquatic Sciences, University of Florida Institute of Food and Agricultural Sciences, Gainesville, Florida.
- Wetzel, R.G. 1983. Limnology. W.B. Saunders Company, Philadelphia, Pennsylvania. 763 pp.

Wolfe, S.H. (editor). 1990. An Ecological Characterization of the Florida Springs Coast: Pithlachascotee to Waccasassa Rivers. Biological Report 90(21), Fish and Wildlife Service and Minerals Management Service, U.S. Department of the Interior. 323 pp.

APPENDIX A

List of Lakes Sampled in the Southwest Florida Water Management District
For the Ambient Monitoring Program

APPENDIX A. Ambient Monitoring Program lakes included in this report

<u>County</u>	<u>Lake Name</u>	<u>Sect-Tshp-Rnge</u>	<u>Latitude</u>	<u>Longitude</u>
Citrus	Bellamy Lake	11-18-19	285558	822224
Citrus	Cato Lake	05-19-20	285200	821948
Citrus	Connell Lake	06-19-20	285212	822114
Citrus	Cooter Lake	17-19-20	285005	821938
Citrus	Croft Lake	30-18-20	285339	822059
Citrus	Davis Lake	22-19-20	284918	821712
Citrus	Dodd Lake	11-18-19	285631	822221
Citrus	Floral City Lake	11-20-20	284630	821705
Citrus	Fort Cooper Lake	27-19-20	284818	821813
Citrus	Hampton Lake	02-20-20	284653	821700
Citrus	Henederson Lake	16-19-20	285021	821901
Citrus	Hernando Lake	24-18-19	285425	822203
Citrus	Hog Pond (Lake Nina)	02-19-19	285216	822230
Citrus	Holden Lake	32-19-20	284741	821935
Citrus	Little Lake (Consuella)	15-20-20	284444	821729
Citrus	Little Henderson Lake	08-19-20	285053	821951
Citrus	Magnolia Lake	03-20-20	284643	821804
Citrus	Rush Lake	03-17-18	290207	822824
Citrus	Spivey Lake	15-19-20	284951	821757
Citrus	Todd Lake	13-18-19	285552	822148
Citrus	Tussock Lake	35-19-20	284744	821618
Citrus	Van Ness Lake	29-18-20	285315	822008
Hernando	Bonnett Pond	28-22-19	283221	822452
Hernando	Bystre Lake	29-22-20	283237	821934
Hernando	Double Cypress Pond	23-22-17	283323	823411
Hernando	Lake Geneva	11-23-21	283008	821057
Hernando	Highland Lake	24-22-17	283308	823341
Hernando	Hunters Lake	32-23-17	282634	823719
Hernando	Irvin Lake	36-22-19	283129	822141
Hernando	Lake Lindsey	25-21-19	283746	822159
Hernando	McClendon Lake	35-23-20	282620	821638
Hernando	McKethan Lake	19-21-20	283849	822014
Hernando	Rock Pond	34-21-19	283701	822320
Hernando	Skinner Lake	13-21-18	283939	822754
Hernando	Sparkman Lake	24-23-19	282754	822151
Hernando	Spring Lake	15-23-20	282935	821740
Hernando	Tank Lake	28-21-19	283720	822443
Hernando	Tooke Lake	13-22-17	283411	823309
Hernando	Unnamed Lake	30-22-18	283207	823232
Highlands	Lake Adelaide	05-33-28	273826	813156
Highlands	Lake Angelo	25-33-28	273510	812800
Highlands	Lake Anoka	27-33-28	273448	813044
Highlands	Lake Apthorpe	18-36-30	272039	812152
Highlands	August Lake	10-37-29	271628	812448
Highlands	Basket Lake	17-34-29	273143	812636
Highlands	Blue Lake	30-36-30	271852	812127
Highlands	Bonnet Lake	08-34-29	273237	812631
Highlands	Brentwood Lake	10-33-28	273717	813040
Highlands	Buck Lake	29-37-30	271405	811958
Highlands	Lake Byrd	09-33-28	273718	813104
Highlands	Lake Carrie	21-36-29	272013	812541

APPENDIX A. (continued)

<u>County</u>	<u>Lake Name</u>	<u>Sect-Tshp-Rnge</u>	<u>Latitude</u>	<u>Longitude</u>
Highlands	Lake Charlotte	17-35-29	272558	812702
Highlands	Chilton Lake	07-33-28	273754	813322
Highlands	Lake Clay	29-36-30	271840	812052
Highlands	Lake Crews	32-36-29	271745	812612
Highlands	Lake Damon	03-33-28	273760	813033
Highlands	Deer Lake	13-33-28	273633	812828
Highlands	Lake Denton	02-34-28	273322	812923
Highlands	Dinner Lake	17-34-29	273056	812634
Highlands	Duck Lake	13-33-28	273645	812844
Highlands	Fox Lake	13-33-28	273628	812801
Highlands	Lake Francis	22-36-29	272023	812422
Highlands	Lake Glenada	34-33-28	273350	813022
Highlands	Grassy Lake	21-37-30	271432	811945
Highlands	Grassy Pond	33-33-29	273404	812503
Highlands	Lake Harry	01-36-29	272210	812227
Highlands	Lake Henry	25-36-29	271924	812302
Highlands	Lake Hill	17-36-29	272059	812619
Highlands	Hog Lake (Granada)	09-34-28	273149	813104
Highlands	Huckleberry Lake	07-35-29	272710	812751
Highlands	Lake Huntley	05-37-30	271711	812035
Highlands	Lake Isis	15-33-28	273642	813039
Highlands	Lake Jackson	30-34-29	272954	812738
Highlands	Lake Josephine Center	32-35-29	272333	812624
Highlands	Lake Josephine East	33-35-29	272349	812541
Highlands	Lake Josephine West	30-35-29	272407	812709
Highlands	Lake June in Winter	34-36-29	271757	812412
Highlands	Lake Lachard	36-36-29	271814	812209
Highlands	Lake Lelia	34-33-28	273424	813016
Highlands	Lake Letta	31-33-29	273340	812742
Highlands	Lake Lillian	09-33-28	273751	813111
Highlands	Little Bonnet Lake	36-33-28	273338	812833
Highlands	Little Jackson Lake	06-35-29	272808	812750
Highlands	Little Red Water Lake (North)	12-34-28	273225	812820
Highlands	Little Red Water Lake (South)	14-36-29	272055	812328
Highlands	Lost Lake	12-37-29	271622	812216
Highlands	Lake Lotela	26-33-28	273438	812855
Highlands	Lake Lucas	21-34-29	273043	812521
Highlands	Lake Lynn	35-35-29	272342	812348
Highlands	Lake McCoy	06-37-30	271702	812115
Highlands	Mirror Lake	07-37-30	271631	812139
Highlands	Lake Nellie Center	13-36-29	272109	812243
Highlands	Lake Nellie NW	13-36-29	272112	812300
Highlands	Lake Nellie SE	13-36-29	272053	812233
Highlands	Lake Olivia	06-33-28	273757	813251
Highlands	Pansy Lake	03-33-28	273831	813047
Highlands	Lake Pearl	06-37-30	271700	812141
Highlands	Persimmon Lake	10-36-29	272117	812422
Highlands	Lake Placid	30-37-30	271345	812145
Highlands	Lake Pythias	02-33-28	273808	812951
Highlands	Red Beach Lake	15-35-29	272556	812414

APPENDIX A. (continued)

<u>County</u>	<u>Lake Name</u>	<u>Sect-Tshp-Rnge</u>	<u>Latitude</u>	<u>Longitude</u>
Highlands	Red Water Lake	14-36-29	272050	812343
Highlands	Lake Ruth	18-35-29	272544	812731
Highlands	Saddlebags Lake	06-37-30	271739	812117
Highlands	Lake Sebring	14-34-28	273139	812902
Highlands	Silver Lake	33-33-28	273358	813123
Highlands	Lake Simmons	24-36-29	272017	812233
Highlands	Lake Sirena	01-37-29	271705	812210
Highlands	Stormwater Pond	23-37-29	271430	812355
Highlands	Lake Tulane	27-33-28	273509	813015
Highlands	Unnamed "B" Lake	17-37-30	271506	812030
Highlands	Unnamed "E" Lake	11-36-29	272157	812338
Highlands	Lake Schumacher	22-34-28	273037	813047
Highlands	Lake Verona	23-33-28	273551	812950
Highlands	Lake Viola	14-33-28	273646	812941
Highlands	Wolf Lake	24-35-28	272519	812825
Hillsborough	Lake Alice	16-27-17	280753	823616
Hillsborough	Lake Allen	10-27-18	280924	822920
Hillsborough	Lake Barbara	19-27-18	280710	823209
Hillsborough	Bay Lake	04-28-18	280414	823004
Hillsborough	Bellows (East) Lake	02-29-19	275923	822249
Hillsborough	Brant Lake	23-27-18	280733	822819
Hillsborough	Calm Lake	14-27-17	280831	823456
Hillsborough	Lake Carroll	15-28-18	280304	822914
Hillsborough	Cedar Lake	11-28-18	280354	822823
Hillsborough	Cedar Lake (East)	11-28-18	280357	822814
Hillsborough	Chapman Lake	25-27-18	280619	822751
Hillsborough	Chapman Lake	25-27-18	280631	822728
Hillsborough	Church Lake	28-27-17	280611	823606
Hillsborough	Crescent Lake	10-27-17	280931	823534
Hillsborough	Lake Cypress	24-27-17	280731	823356
Hillsborough	Deer Lake	01-27-18	281003	822747
Hillsborough	Dosson Lake	20-27-18	280723	823132
Hillsborough	Lake Eckles	14-28-18	280321	822817
Hillsborough	Egypt Lake	27-28-18	280040	822933
Hillsborough	Lake Ellen	10-28-18	280340	822949
Hillsborough	Lake Ellen	25-27-18	280600	822724
Hillsborough	Lake Ellen	19-27-18	280716	823208
Hillsborough	Lake Estes	24-27-18	280710	822758
Hillsborough	Lake Eva	22-27-17	280708	823535
Hillsborough	Gant Lake	01-28-17	280420	823341
Hillsborough	Golden Trout Lake	02-28-18	280427	822818
Hillsborough	Gornito Lake	21-29-19	275642	821901
Hillsborough	Grace Lake	34-27-17	280549	823517
Hillsborough	Halfmoon Lake	31-27-18	280546	823251
Hillsborough	Lake Helen	19-27-18	280717	823219
Hillsborough	Hog Island Lake	06-27-19	281009	822656
Hillsborough	Horse Lake	26-27-17	280638	823446
Hillsborough	Island Ford Lake	10-27-17	280909	823559
Hillsborough	Lake Jackson	17-27-17	280815	823748
Hillsborough	Lake Juanita	22-27-17	280702	823521

APPENDIX A. (continued)

<u>County</u>	<u>Lake Name</u>	<u>Sect-Tshp-Rnge</u>	<u>Latitude</u>	<u>Longitude</u>
Hillsborough	Keystone Lake	15-27-17	280759	823528
Hillsborough	Little Deer Lake	01-27-18	280949	822756
Hillsborough	Little Halfmoon Lake	30-27-18	280611	823300
Hillsborough	Little Moon Lake	28-27-17	280648	823602
Hillsborough	Long Pond	13-29-20	275756	821556
Hillsborough	Lake Magdalene	02-28-18	280453	822857
Hillsborough	Lake Mango	09-29-20	275805	821808
Hillsborough	Marlee Lake	28-27-17	280559	823630
Hillsborough	Mead Lake	22-29-20	275652	821742
Hillsborough	Lake Merrywater	22-27-18	280723	822914
Hillsborough	Platt Lake	35-27-18	280540	822844
Hillsborough	Pretty Lake	26-27-17	280626	823404
Hillsborough	Rainbow Lake	22-27-17	280657	823547
Hillsborough	Lake Raleigh	27-27-17	280620	823503
Hillsborough	Lake Reinheimer	15-27-18	280747	822913
Hillsborough	Lake Rogers	27-27-17	280631	823520
Hillsborough	Round Lake	22-27-18	280714	823001
Hillsborough	Sapphire Lake	14-27-18	280826	822853
Hillsborough	Starvation Lake	21-27-18	280725	823018
Hillsborough	Lake Stemper	13-27-18	280802	822726
Hillsborough	Sunset Lake	17-27-17	280806	823733
Hillsborough	Sunshine Lake	20-27-18	280710	823132
Hillsborough	Lake Taylor	16-27-17	280810	823646
Hillsborough	Tenmile Lake	20-29-20	275624	821854
Hillsborough	Thorpe Lake	28-27-17	280603	823618
Hillsborough	Turkey Ford Lake	18-27-18	280757	823226
Hillsborough	Twin Lake	22-28-18	280157	822923
Hillsborough	Valrico Lake	13-29-20	275711	821529
Hillsborough	Wastena Lake	03-27-17	280946	823529
Hillsborough	Lake Weeks	01-29-20	275921	821608
Hillsborough	White Trout Lake	22-28-18	280221	822946
Hillsborough	Williams Lake	33-27-17	280555	823611
Hillsborough	Lake Wimauma	09-32-20	274229	821845
Hillsborough	Wood Lake	11-27-17	280917	823439
Hillsborough	Zambito Lake	22-27-18	280650	822929
Levy	Lake Marion	02-14-17	291743	823434
Marion	Bonable Lake	31-15-18	290815	823123
Marion	Little Bonable Lake	30-15-18	290906	823153
Marion	Little Bream Lake	19-16-18	290438	823158
Marion	Lake Otting	30-16-20	290422	822033
Marion	Tiger Lake	32-15-18	290751	823101
Pasco	Banjo Lake	18-26-19	281309	822632
Pasco	Bell Lake	13-26-18	281317	822714
Pasco	Lake Bernadette	08-26-21	281404	821403
Pasco	Big Lake Vienna	23-26-18	281221	822818
Pasco	Bird Lake	36-26-18	281050	822713
Pasco	Black Lake	26-26-17	281125	823437
Pasco	Blanton Lake	18-24-21	282409	821450
Pasco	Crews Lake	16-24-18	282341	823039
Pasco	Dowling Lake	31-23-21	282611	821459

APPENDIX A. (continued)

<u>County</u>	<u>Lake Name</u>	<u>Sect-Tshp-Rnge</u>	<u>Latitude</u>	<u>Longitude</u>
Pasco	East (Cow) Lake	19-26-19	281233	822627
Pasco	Fishing Lake	34-26-17	281057	823519
Pasco	Floyd Lake	36-26-18	281107	822753
Pasco	Gooseneck Lake	29-26-19	281143	822546
Pasco	Green Lake	16-25-18	281857	823011
Pasco	Lake Hancock	05-24-20	282556	821957
Pasco	Hunters Lake	04-25-17	281958	823628
Pasco	Lake Iola	15-24-20	282338	821753
Pasco	Jessamine Lake	11-24-20	282507	821621
Pasco	King Lake	07-26-19	281349	822707
Pasco	King (East) Lake	22-25-20	281727	821736
Pasco	Loyce Lake	22-24-18	282230	822943
Pasco	Middle Lake	04-24-20	282517	821855
Pasco	Moody Lake (East)	10-24-20	282431	821740
Pasco	Moody Lake (West)	10-24-20	282445	821804
Pasco	Moon Lake	28-25-17	281706	823639
Pasco	Moss Lake	35-26-18	281034	822856
Pasco	Lake Padgett	24-26-18	281220	822737
Pasco	Parker Lake	35-26-17	281039	823454
Pasco	Lake Pasadena	16-25-21	281912	821320
Pasco	Pierce Lake	09-25-18	281916	823050
Pasco	Sumner Lake	36-24-21	282136	820942
Pasco	Lake Thomas	11-26-18	281427	822812
Pasco	Treasure (Lucy) Lake	01-26-18	281453	822740
Pasco	Turtle (Tampa) Lake	32-26-19	281026	822529
Pasco	Twin Lake	28-26-19	281119	822507
Pasco	Unnamed Pasco Lake	02-24-17	282532	823445
Pasco	Vienna Lake	24-26-18	281245	822801
Pasco	West Moon Lake	29-25-17	281715	823722
Pasco	Wistaria Lake	02-26-18	281504	822838
Pasco	Lake Worrell	26-25-16	281701	824006
Pinellas	Alligator Lake	09-29-16	275852	824154
Pinellas	Beckett Lake	06-29-16	275927	824447
Pinellas	Bellevue Lake	22-29-15	275649	824739
Pinellas	Lake Bowden (Chautauqua)	32-28-16	280016	824323
Pinellas	Crescent Lake	18-31-17	274717	823830
Pinellas	Crest (Excelsior) Lake	14-29-15	275745	824620
Pinellas	Freedom Lake	21-30-16	275144	824153
Pinellas	Harbor Lake	36-28-15	275948	824453
Pinellas	Lake Maggiore	36-31-16	274414	823914
Pinellas	Mirror Lake	19-31-17	274627	823833
Pinellas	Pasadena Lake	20-31-16	274630	824328
Pinellas	Sawgrass Lake	26-30-16	275027	824021
Pinellas	Saint George Lake	08-28-16	280342	824311
Pinellas	Taylor Lake	04-30-15	275417	824816
Polk	Lake Agnes	04-27-25	281009	814906
Polk	Lake Alfred	30-27-26	280601	814442
Polk	Lake Ariana	03-28-25	280444	814753
Polk	Lake Arietta	27-27-25	280609	814813
Polk	Lake Bess	18-29-27	275800	813912

APPENDIX A. (continued)

<u>County</u>	<u>Lake Name</u>	<u>Sect-Tshp-Rnge</u>	<u>Latitude</u>	<u>Longitude</u>
Polk	Blue Lake (Big)	24-30-27	275105	813439
Polk	Blue Lake (Little)	24-30-27	275121	813450
Polk	Lake Bonny	20-28-24	280217	815530
Polk	Lake Buffum	12-31-26	274753	813952
Polk	Lake Cannon	19-28-26	280219	814511
Polk	Lake Clinch	31-31-28	274440	813256
Polk	Lake Conine	09-28-26	280335	814330
Polk	Crooked Lake	01-31-27	274906	813349
Polk	Cypress Lake	36-29-28	275451	812847
Polk	Lake Daisy	06-29-27	275948	813934
Polk	Lake Davenport	04-27-27	280935	813637
Polk	Lake Deeson	29-27-24	280644	815550
Polk	Eagle Lake	01-29-25	275908	814553
Polk	Lake Echo	05-28-26	280456	814403
Polk	Lake Effie	03-30-27	275429	813619
Polk	Lake Elbert	22-28-26	280133	814233
Polk	Lake Eloise	03-29-26	275859	814213
Polk	Lake Fannie	11-28-26	280334	814124
Polk	Gadau Lake	23-30-26	275138	814142
Polk	Lake Galloway (Hidden)	27-27-23	280648	820011
Polk	Lake Garfield	05-30-26	275415	814358
Polk	Lake Gibson	25-27-23	280631	815740
Polk	Lake Gordon	21-30-27	275120	813739
Polk	Lake Gordon (SW)	21-30-27	275051	813752
Polk	Lake Haines	33-27-26	280531	814224
Polk	Lake Hamilton	18-28-27	280256	813910
Polk	Lake Hancock	08-29-25	275819	815019
Polk	Lake Hartridge	08-28-26	280320	814433
Polk	Lake Henry	36-27-26	280526	814000
Polk	Lake Hickory	17-32-28	274202	813224
Polk	Lake Howard	30-28-26	280127	814442
Polk	Lake Ida (Frostproof)	28-31-28	274544	813118
Polk	Lake Ida (Winter Haven)	17-28-26	280302	814359
Polk	Lake Idyl	16-28-26	280229	814247
Polk	Idylwild Lake	18-28-26	280302	814523
Polk	Lake Isabell	36-32-28	273858	812837
Polk	Lake Jessie	12-28-25	280328	814549
Polk	Lake Juliana	15-27-25	280750	814812
Polk	Lake Lena	09-28-25	280356	814832
Polk	Lake Leonore	10-31-28	274745	813044
Polk	Lester Lake	22-27-23	280721	815953
Polk	Little Crooked Lake	23-31-27	274613	813430
Polk	Lake Lulu	04-29-26	275946	814316
Polk	Lake Mabel	11-29-27	275811	813519
Polk	Lake Mattie	14-27-25	280810	814647
Polk	Lake May	29-28-26	280047	814413
Polk	Lake McLeod	07-29-26	275801	814511
Polk	Lake Moody	17-31-28	274650	813153
Polk	Mud Lake	06-27-25	281009	815037
Polk	Lake Myrtle	19-29-27	275650	813904

APPENDIX A. (continued)

<u>County</u>	<u>Lake Name</u>	<u>Sect-Tshp-Rnge</u>	<u>Latitude</u>	<u>Longitude</u>
Polk	Pabor Lake	33-32-28	273850	813108
Polk	Lake Pansy	08-28-26	280404	814433
Polk	Lake Parker	32-29-27	275449	813814
Polk	Reedy Lake	35-31-28	274414	813000
Polk	Lake Rochelle	04-28-26	280422	814313
Polk	Lake Ruby	12-29-26	275812	813943
Polk	Scott Lake	18-29-24	275756	815624
Polk	Lake Shipp	32-28-26	280008	814433
Polk	Spirit Lake	35-28-25	275959	814637
Polk	Lake Starr	14-29-27	275725	813514
Polk	Lake Streety	24-32-27	274048	813419
Polk	Surveyors Lake	26-30-26	275008	814140
Polk	Lake Swoope	29-27-26	280607	814331
Polk	Lake Tennessee	09-27-25	280839	814848
Polk	Trout Lake	34-32-28	273848	813029
Polk	Lake Van	25-27-25	280624	814601
Polk	Lake Wales	01-30-27	275405	813420
Polk	Lake Winterset	11-29-26	275825	814056
Sumter	Big Gant Lake	14-22-22	283434	820507
Sumter	Lake Deaton	14-19-23	285006	815858
Sumter	Lake Miona	27-18-23	285409	820017
Sumter	Lake Okahumpka	21-19-23	284928	820027

APPENDIX B

Distributions of the water chemistry parameters for all lakes sampled for the Southwest Florida Water Management District Lakes Ambient Monitoring Program

Appendix B, *plots a, b*. Plots of sample lake distributions for surface area (*a, top*) and calcium (*b, bottom*). The median value was used to represent the concentration or measure for each lake.

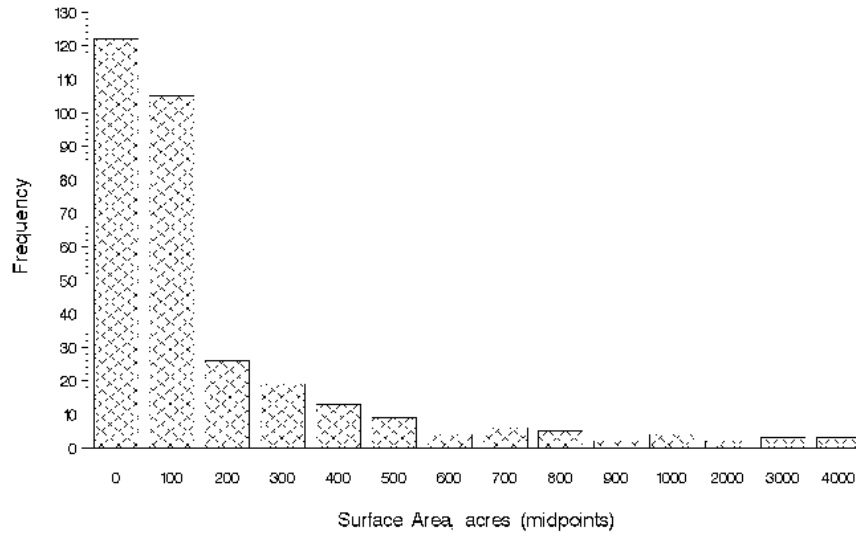

NOTE: midpoint distance scale is greater above 1000 acres

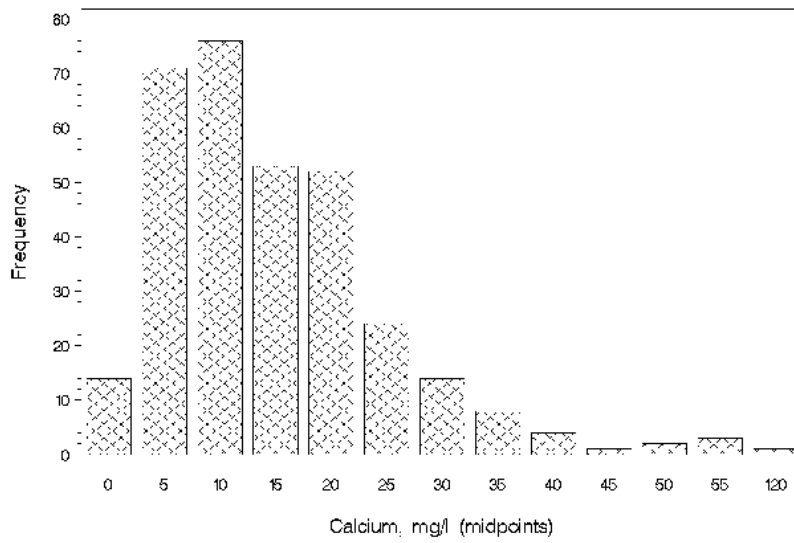

NOTE: midpoint distance scale is greater above 55 mg/l

Appendix B, *plots c, d*. Plots of sample lake distributions for chlorophyll *a* (*c, top*) and chloride (*d, bottom*). The median value was used to represent the concentration for each lake.

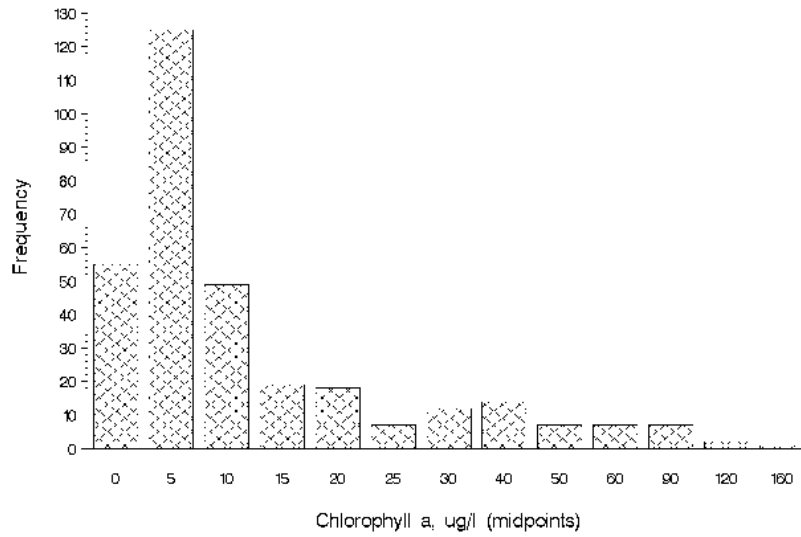

NOTE: midpoint distance scale is greater above 30 ug/l

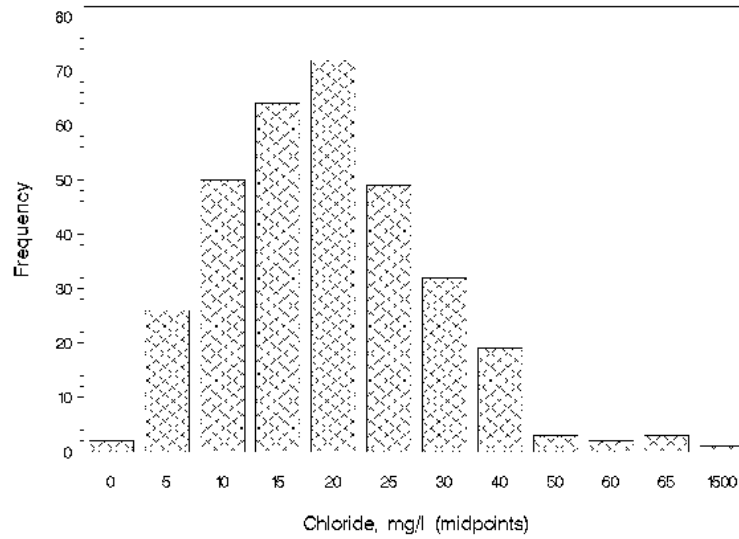

NOTE: midpoint distance scale is greater above 65 ug/l

Appendix B, *plots e, f*. Plots of sample lake distributions for color (*e, top*) and conductivity (*f, bottom*). The median value was used to represent the concentration or measure for each lake.

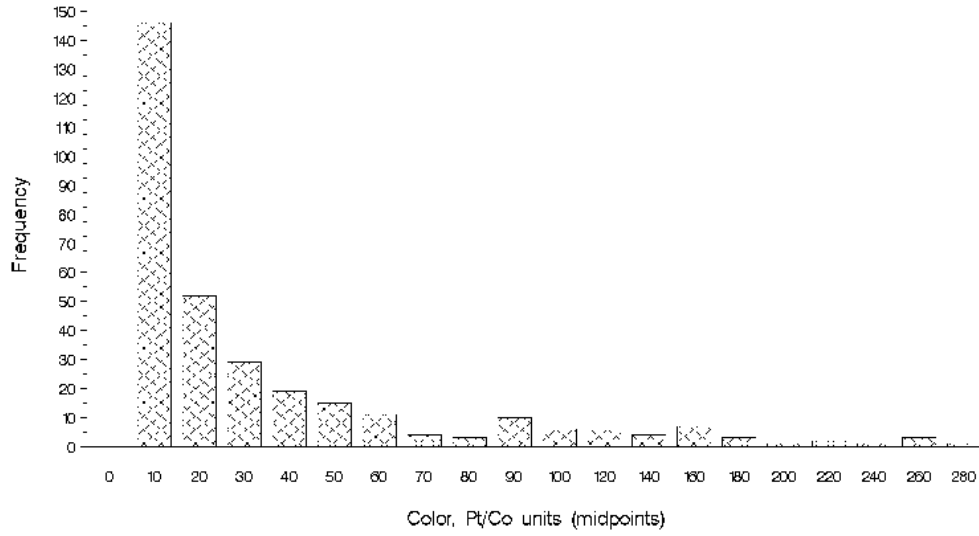

NOTE: midpoint distance scale is greater above 100 color units

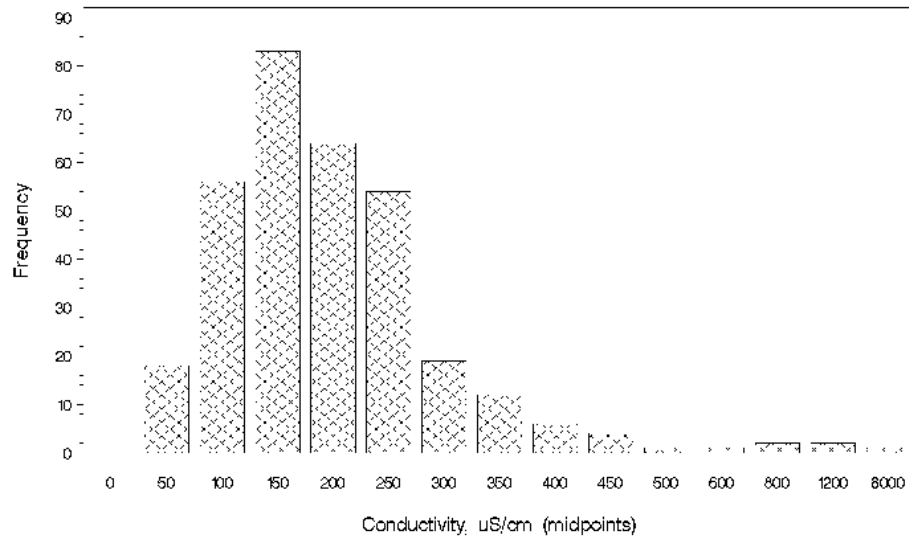

NOTE: midpoint distance scale varies above 500 uS

Appendix B, *plots g, h*. Plots of sample lake distributions for iron (*g, top*) and Florida TSI (*h, bottom*). The median value was used to represent the concentration or measure for each lake.

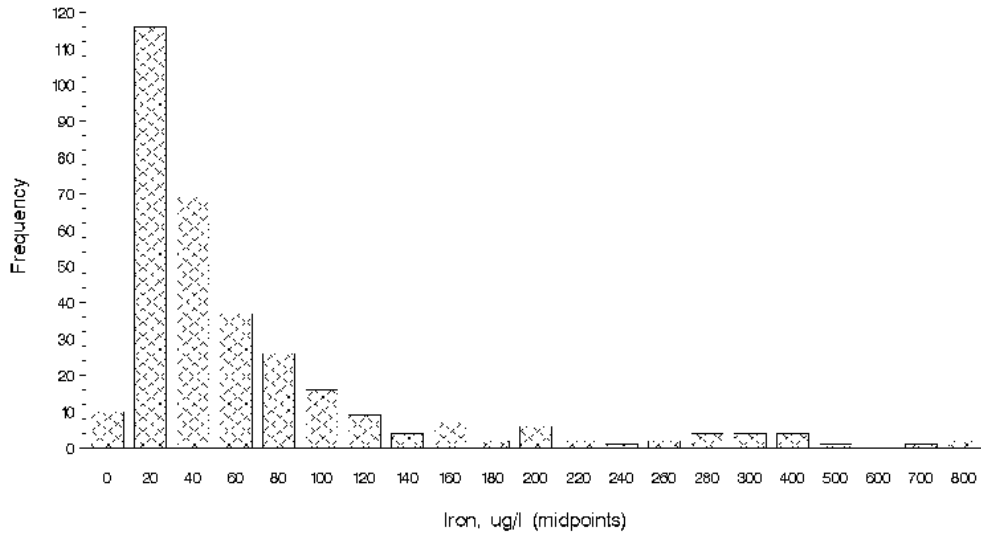

NOTE: midpoint distance scale is greater above 300 ug/l

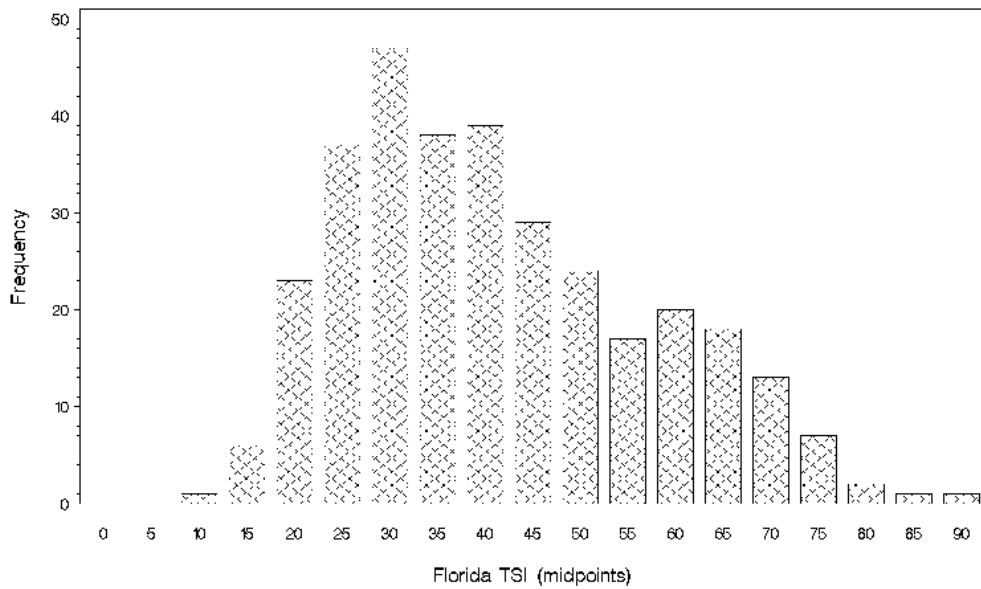

Appendix B, plots *i, j*. Plots of sample lake distributions plots for total hardness (*i, top*) and potassium (*j, bottom*). The median value was used to represent the concentration for each lake.

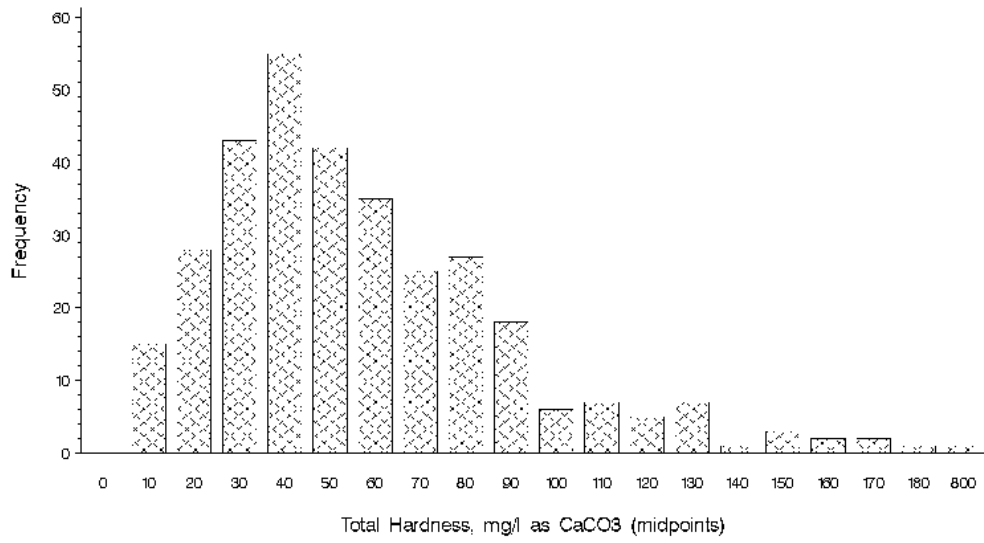

NOTE: midpoint distance scale is greater above 180 mg/l

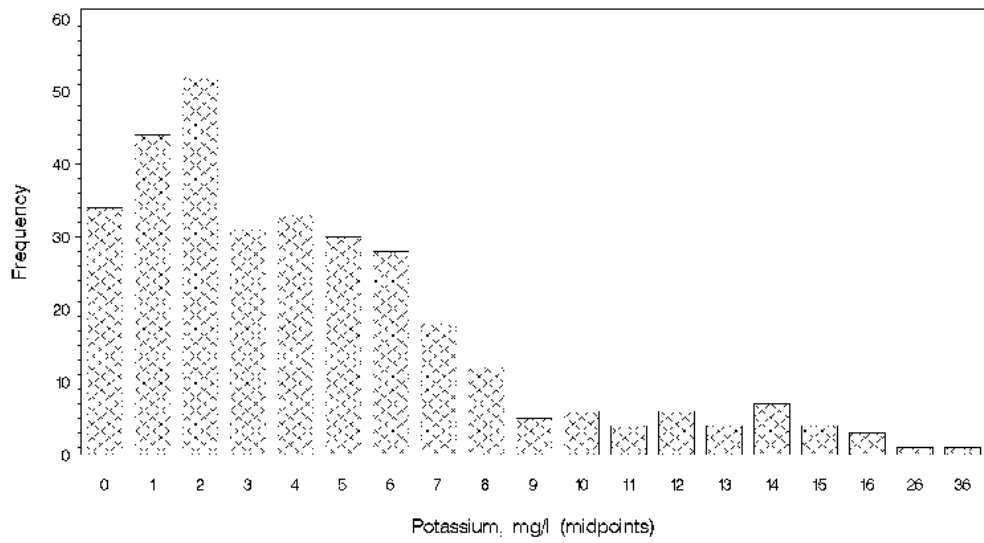

NOTE: midpoint distance scale is greater above 16 mg/l

Appendix B, *plots k, l*. Plots of the sample lake distributions for magnesium (*k, top*) and sodium (*l, bottom*). The median value was used to represent the concentration for each lake.

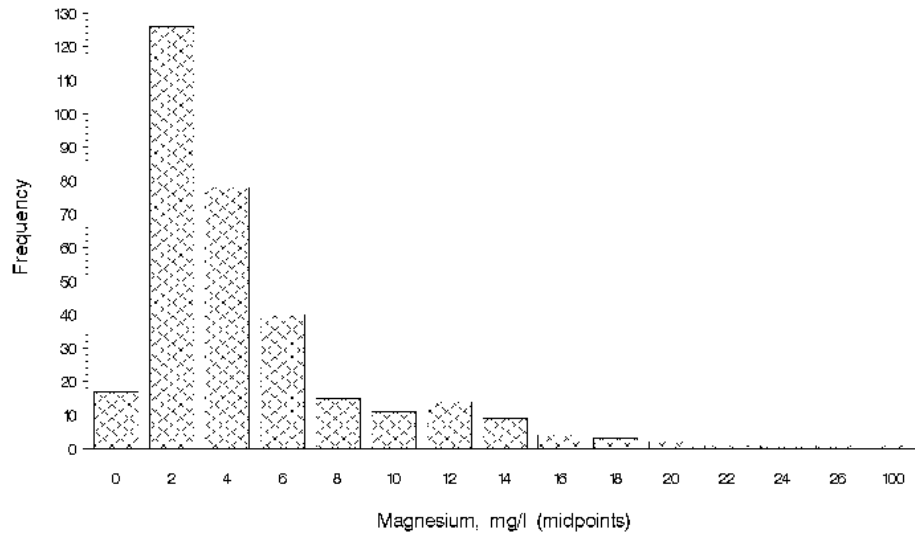

NOTE: midpoint distance scale is greater above 26 mg/l

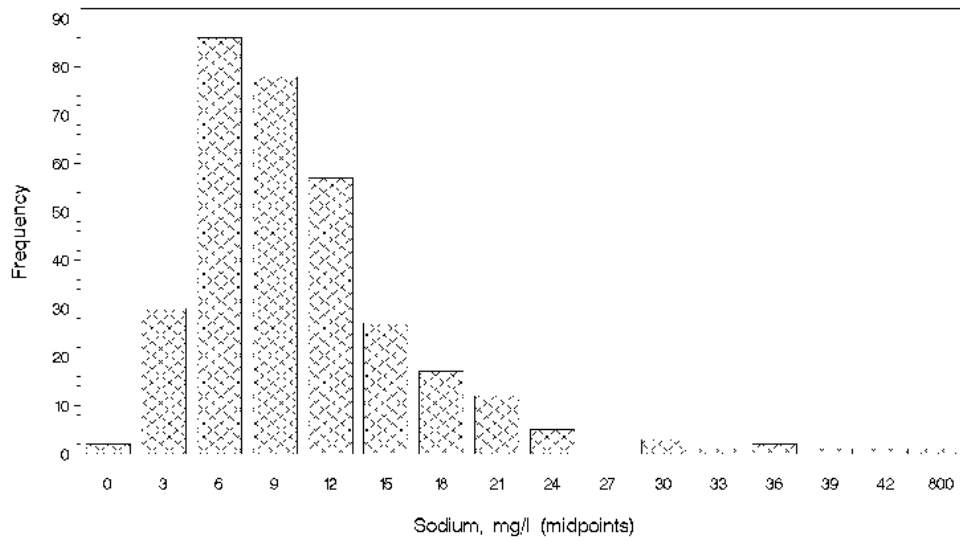

NOTE: midpoint distance scale is greater above 42 mg/l

Appendix B, *plots m, n*. Plots of the sample lake distributions for ammonia (*m, top*) and nitrate+nitrite (*n, bottom*). The median value was used to represent the concentration for each lake.

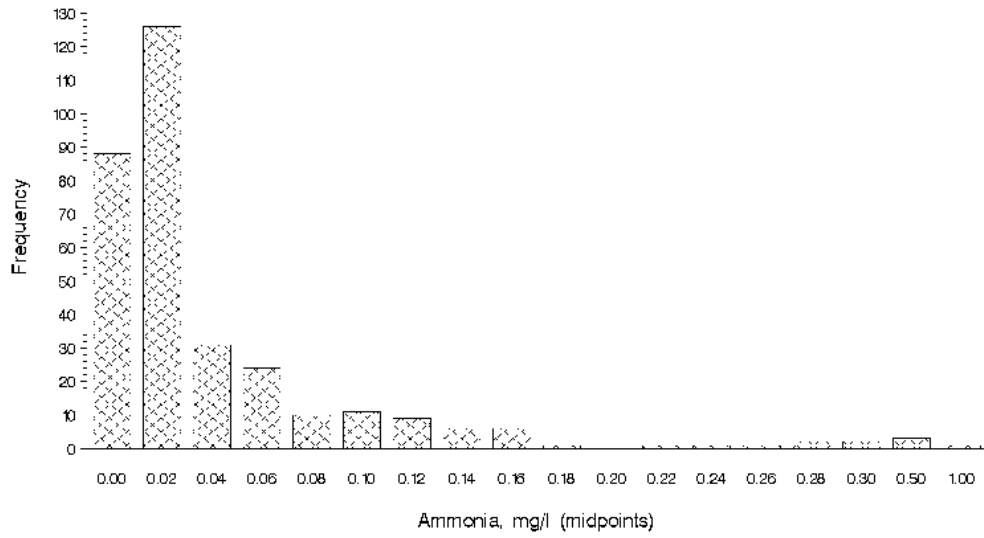

NOTE: midpoint distance scale varies above 0.30 mg/l

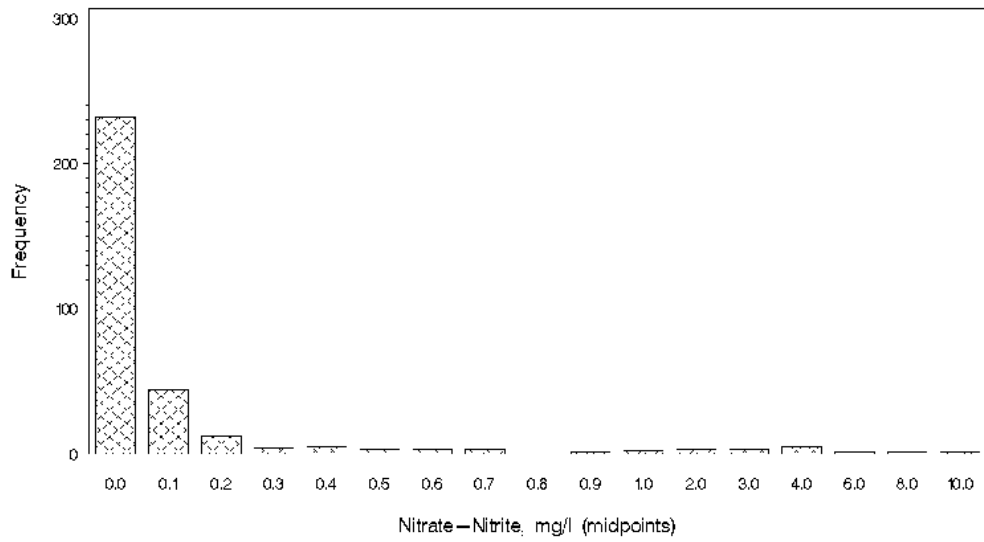

NOTE: midpoint distance scale varies above 1.0 mg/l

Appendix B, *plots o, p*. Plots of sample lake distributions for orthophosphorus (*o, top*) and pH (*p, bottom*). The median value was used to represent the concentration for each lake.

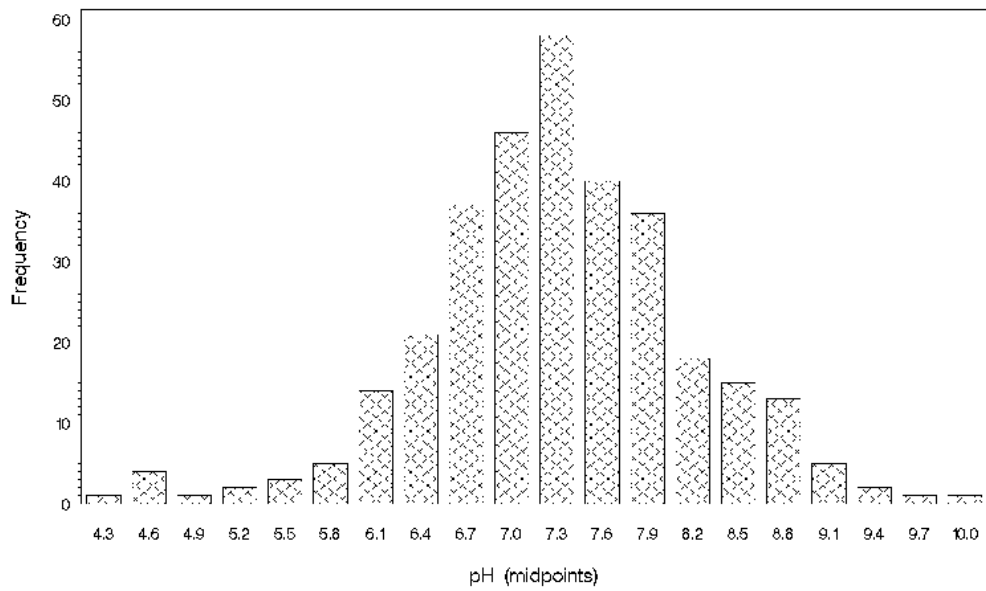
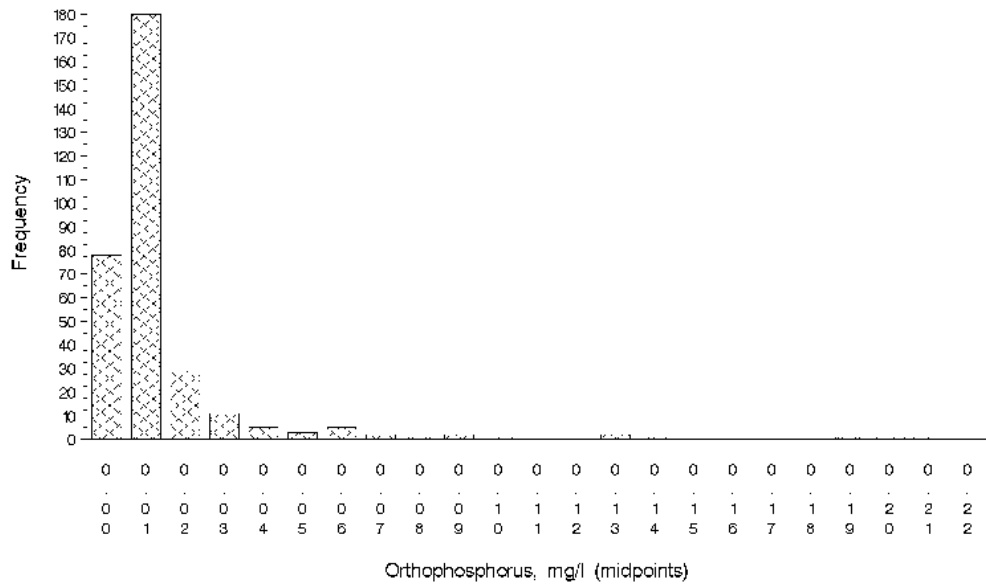

Appendix B, *plots q, r*. Plots of sample lake distributions for pheophytin (*q, top*) and Secchi depth (*r, bottom*). The median value was used to represent the concentration for each lake.

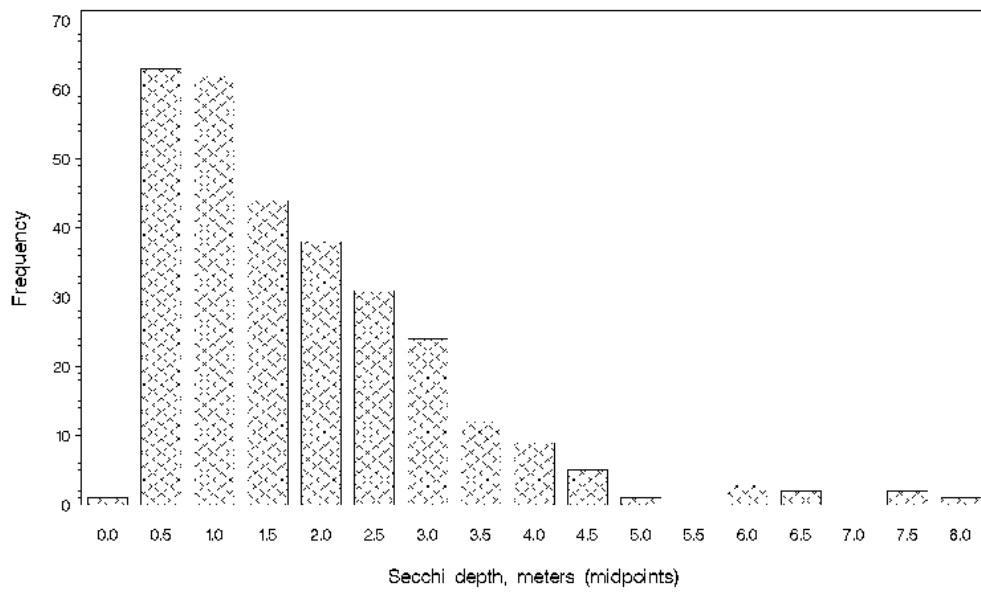
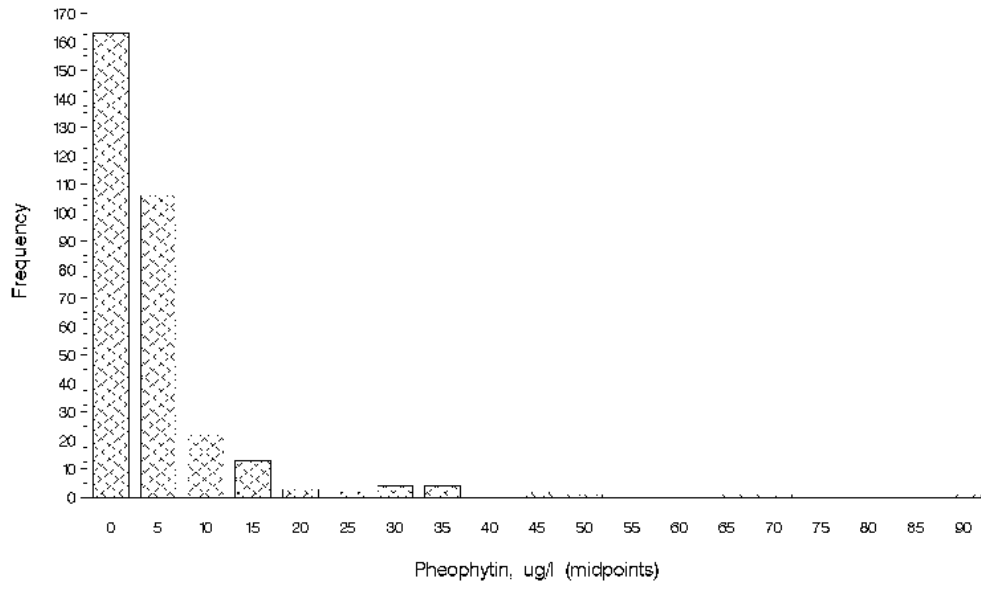

Appendix B, *plots s, t*. Plots of sample lake distributions for sulfate (*s, top*) and total alkalinity (*t, bottom*). The median value was used to represent the concentration for each lake.

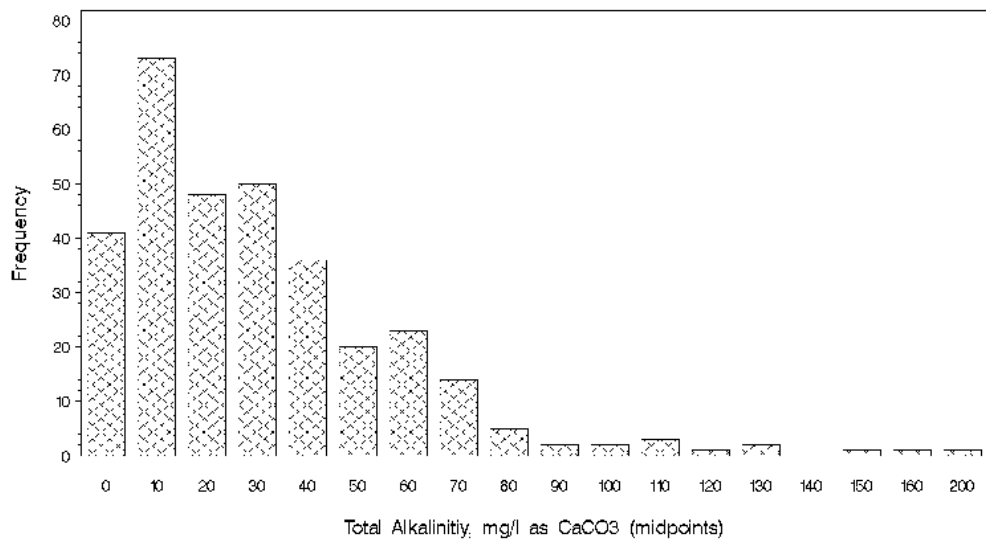
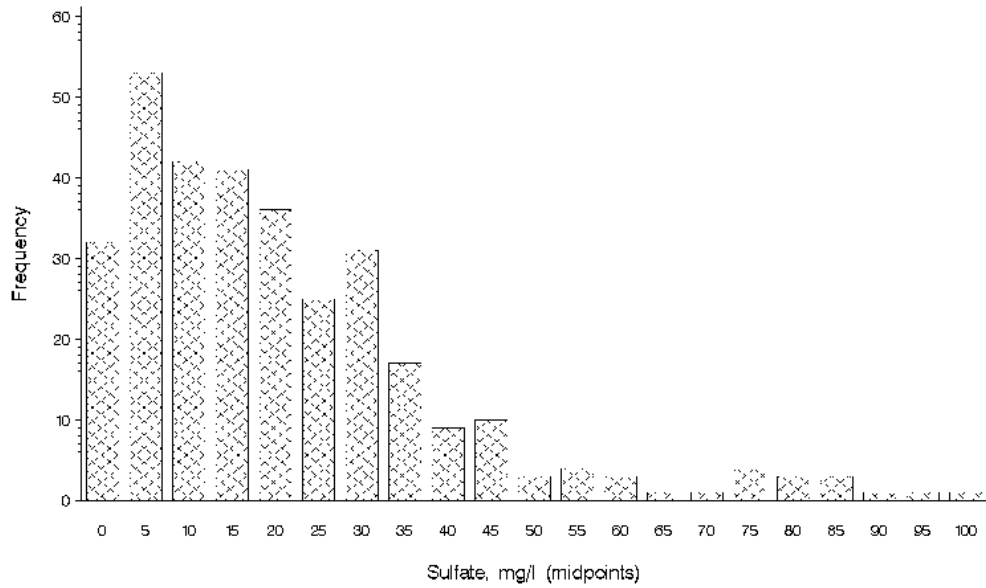

NOTE: midpoint distance scale is greater above 160 mg/l

Appendix B, *plots u, v*. Plots of sample lake distributions for total Kjeldahl nitrogen (*u, top*) and total nitrogen (*v, bottom*). The median value was used to represent the concentration for each lake.

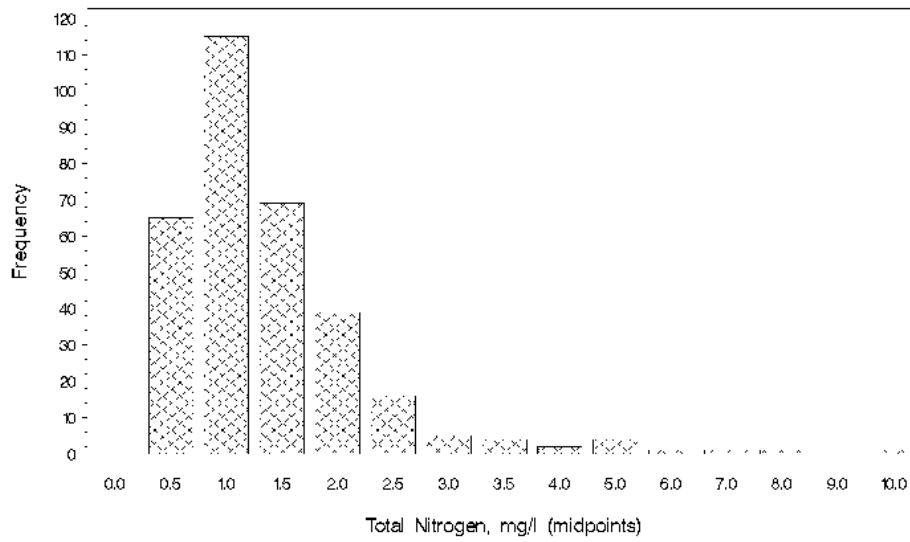
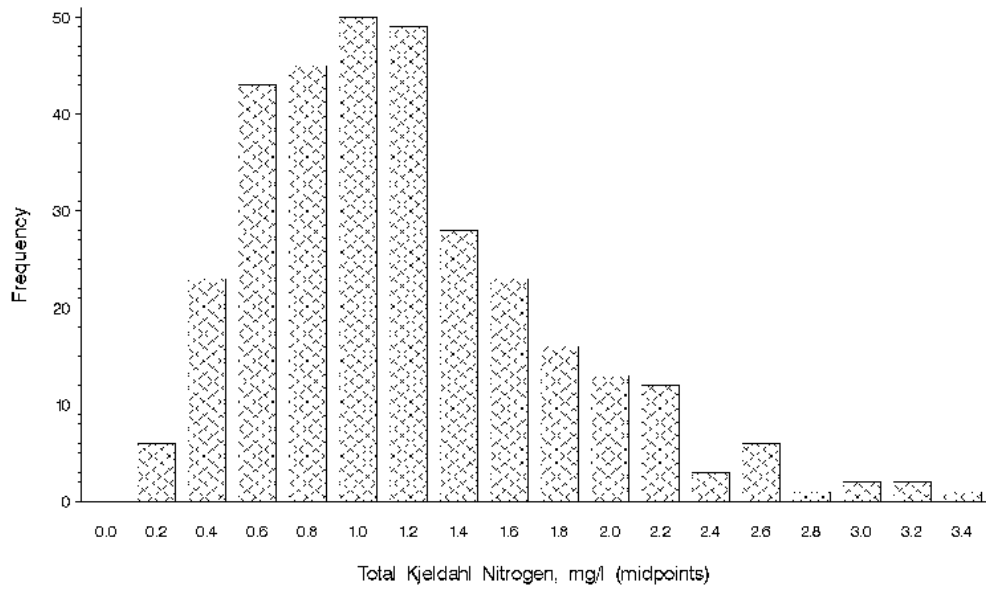

NOTE: midpoint distance scale varies above 4.0 mg/l

Appendix B, *plots w, x*. Plots of sample lake distributions for total phosphorus (*w, top*) and total suspended solids (*x, bottom*). The median concentration was used for each lake. Appendix B, *plot y*. Plot of the sample lake distribution for turbidity. The median concentration was used for each lake.

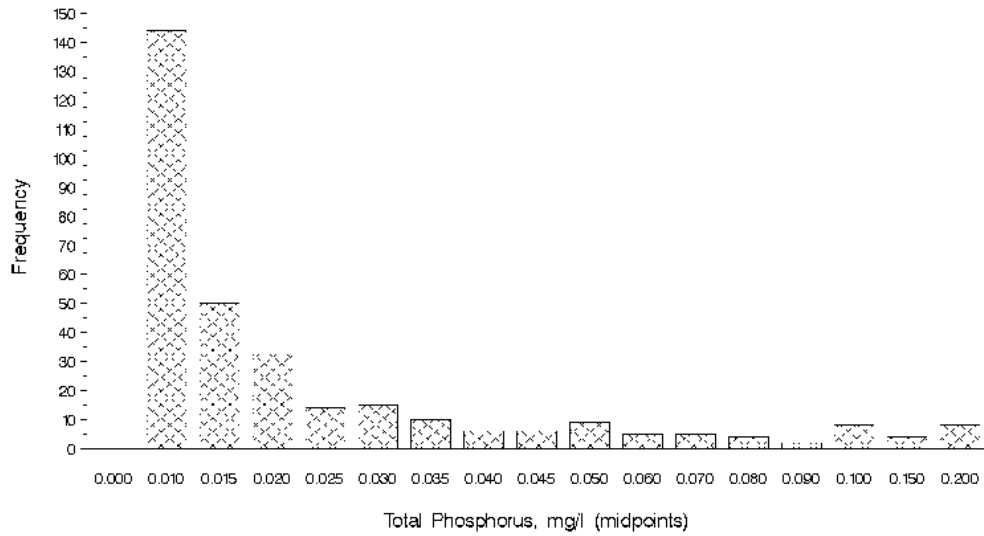

NOTE: midpoint distance scale varies above 0.05 mg/l

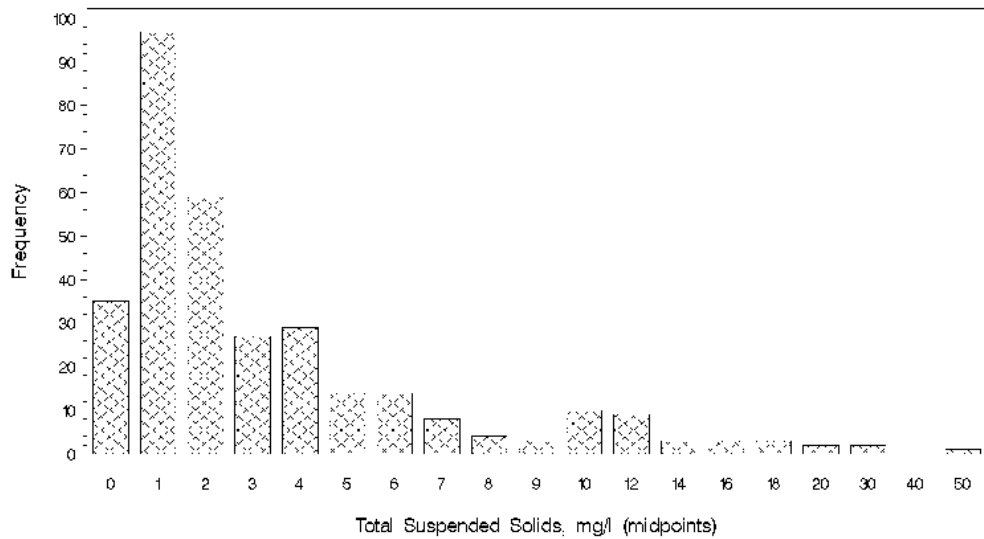

NOTE: midpoint distance scale varies above 10 mg/l

APPENDIX C

Lake Water Chemistry vs. Soil Series, for 323 Sampled Lakes
in the Southwest Florida Water Management District.

APPENDIX C. Lake water chemistry vs. soil series, for 323 sampled lakes in the Southwest Florida Water Management District. Data to describe the soil series around each of the lakes were generated using GIS (Arc/Info). Lacking lake-specific drainage basin maps or coverages for each lake, it was assumed that the area immediately surrounding a lake was likely representative of soils within the drainage basin. Using the GIS, a 500 meter buffer was constructed around each lake. Within the buffer area, data were extracted from the GIS data base for soil series. These data were reduced to percentages of each soil series of the total 500-meter buffer area.

Many soil series were not strongly represented in the data set, in other words, they were infrequently encountered around lakes or were of very limited surface area. Therefore, the data for correlations were further reduced by not calculating correlations for soil series represented within the 500 meter buffers of fewer than 26 lakes, or lakes having a range of total 500-meter buffer area coverage of less than 25 percent. There were gradations within each series, for example, for the Samsula series, there were Samsula muck, Samsula muck/depressional, and Samsula-Martel Complex/depressional. These were lumped into the primary series, 'Samsula'.

The correlations frequently suggest a relationship between soils and lake water chemistry. All of the significant correlations are plotted following the correlation summary pages. A regression line is shown on each plot to show the suggested relationship, however, the data for soils percent area and for water quality were not normally distributed which violates the normality assumption of regression statistics. The regression line is not significant.

It is important to note that for all correlations and plots in which coverage is expressed as a percentage, the remaining percentage is composed of another or perhaps several different land uses. These other land uses may have a greater, inverse influence on water chemistry than the land use for which the correlation is significant.

Abbreviations:

ADAMSVIL=Adamsville
ARREDOND=Arredondo
SATELLIT=Satellite
CA=calcium
CHLA=chlorophyll *a*
CL=chloride
COND=conductance
FE=iron
FTSI=Florida trophic state index
HARD=total hardness
K=potassium
MG=magnesium

NA=sodium
NOX=nitrate+nitrite
ORTP=orthophosphorus
PH=pH
SECCHI=transparency, Secchi depth
SO4=sulfate
TALK=total alkalinity
TKN=total Kjeldahl nitrogen TN=total nitrogen
TP=total phosphorus
TSS=total suspended solids
TURB=turbidity

Spearman Rank Correlation, lake water chemistry by soil

Correlation Analysis

20 'WITH' Variables: ADAMSVIL ARCHBOLD ARREDOND ASTATULA BASINGER CANDLER HONTOON
 LAKE MYAKKA PAOLA PLACID POMELLO POMONA POMPANO
 SAMSULA SATELLIT SMYRNA SPARR TAVARES ZOLFO
 22 'VAR' Variables: CA CHLA CL COLOR COND FE FTSI
 HARD K MG NA NOX ORTP PH
 SECCHI S04 TALK TKN TN TP TSS
 TURB

Simple Statistics

Variable	N	Mean	Std Dev	Median	Minimum	Maximum	Label
ADAMSVIL	137	12.0438	11.7209	8.0000	0	55.0000	
ARCHBOLD	53	9.0000	9.2237	6.0000	0	44.0000	
ARREDOND	31	13.1613	16.3424	4.0000	0	53.0000	
ASTATULA	98	43.3469	31.6120	38.0000	0	100.0	
BASINGER	222	13.4550	11.8629	12.0000	0	86.0000	
CANDLER	124	26.5484	25.3382	18.0000	0	100.0	
HONTOON	61	7.0492	8.7453	3.0000	0	39.0000	
LAKE	31	17.3871	15.3984	12.0000	0	61.0000	
MYAKKA	154	20.0649	16.4546	18.0000	0	55.0000	
PAOLA	26	14.8846	18.9554	9.0000	0	75.0000	
PLACID	102	4.5196	5.7139	3.0000	0	38.0000	
POMELLO	85	4.2941	5.1728	2.0000	0	25.0000	
POMONA	55	6.7818	7.9923	4.0000	0	37.0000	
POMPANO	50	5.1400	7.5593	2.0000	0	43.0000	
SAMSULA	99	6.2222	6.4485	4.0000	0	38.0000	
SATELLIT	53	17.7736	19.1850	13.0000	0	66.0000	
SMYRNA	121	8.2562	10.8409	4.0000	0	59.0000	
SPARR	92	9.7283	12.8654	4.5000	0	67.0000	
TAVARES	178	14.8090	13.8142	11.0000	0	59.0000	
ZOLFO	95	23.6526	19.2988	20.0000	0	69.0000	
CA	323	14.5635	9.8060	12.5000	1.0000	55.0000	Calcium
CHLA	323	14.2449	20.6599	6.2000	1.0000	146.8	Chlorophyll a
CL	323	19.8793	10.5593	19.0000	2.0000	67.0000	Chloride
COLOR	323	37.2291	50.1010	18.0000	4.0000	289.0	Color
COND	323	198.6	128.0	179.0	25.0000	1284.0	Conductance
FE	323	71.5068	98.2602	37.0000	0	773.5	Iron
FTSI	323	42.0774	15.8150	39.0000	12.0000	92.0000	Florida TSI
HARD	323	56.1176	32.5092	48.0000	5.0000	178.0	Hardness
K	323	4.3765	3.8927	3.7000	0	26.5000	Potassium
MG	323	4.7854	4.2807	3.4000	0.5000	26.4000	Magnesium
NA	323	10.4474	6.3360	8.8000	1.1000	41.5000	Sodium
NOX	323	0.2504	0.9298	0.0190	0.00500	7.3130	Nitrate+Nitrite
ORTP	323	0.0150	0.0259	0.00800	0	0.2080	Ortho P
PH	323	7.2935	0.8669	7.3000	4.4000	10.0000	pH
SECCHI	298	1.8127	1.3191	1.5000	0.2000	8.0500	Transparency
S04	322	21.0466	18.8848	16.0000	0	98.0000	Sulfate
TALK	323	30.5170	28.2716	24.0000	0	217.0	Total Alkalinity
TKN	323	1.1667	0.5789	1.0700	0.1200	3.4100	TKN
TN	323	1.4164	1.0139	1.1900	0.3100	7.7500	Total N
TP	323	0.0268	0.0366	0.0140	0.00500	0.2300	Total P
TSS	323	3.6480	4.9842	2.0000	0	47.2000	TSS
TURB	323	4.0904	5.2602	2.0000	0.1000	31.9000	Turbidity

Spearman Rank Correlation, lake water chemistry by soil

Correlation Analysis

Spearman Correlation Coefficients / Prob > |R| under Ho: Rho=0 / Number of Observations

ADAMSVIL

NA	CA	TALK	NOX	SECCHI
0.18203	0.13842	0.13575	-0.10286	0.10129
0.0333	0.1067	0.1137	0.2317	0.2690
137	137	137	137	121
HARD	TP	MG	COLOR	FE
0.08490	-0.08046	-0.07907	-0.07865	-0.07391
0.3239	0.3500	0.3584	0.3610	0.3907
137	137	137	137	137

ARCHBOLD

ORTP	CL	CA	COLOR	FTSI
0.45012	-0.31779	-0.31563	0.31365	0.31331
0.0007	0.0204	0.0213	0.0222	0.0223
53	53	53	53	53
HARD	NA	TP	FE	SECCHI
-0.30637	-0.27416	0.27240	0.27149	-0.26049
0.0257	0.0470	0.0485	0.0492	0.0622
53	53	53	53	52

ARREDOND

CA	TALK	HARD	MG	NA
-0.60161	-0.59340	-0.41473	0.27351	-0.20471
0.0003	0.0004	0.0204	0.1365	0.2693
31	31	31	31	31
TP	COND	S04	FE	COLOR
-0.18854	-0.18383	0.18188	-0.17049	-0.15901
0.3097	0.3222	0.3274	0.3592	0.3929
31	31	31	31	31

ASTATULA

COLOR	S04	K	MG	NOX
-0.54683	0.48047	0.47788	0.46854	0.44503
0.0001	0.0001	0.0001	0.0001	0.0001
98	97	98	98	98
FE	COND	SECCHI	HARD	FTSI
-0.38425	0.38411	0.31161	0.31065	-0.25679
0.0001	0.0001	0.0025	0.0019	0.0107
98	98	92	98	98

BASINGER

PH	TALK	MG	K	HARD
-0.42872	-0.29195	-0.28448	-0.27436	-0.27184
0.0001	0.0001	0.0001	0.0001	0.0001
222	222	222	222	222
COLOR	FE	COND	CA	CHLA
0.26701	0.20633	-0.19640	-0.17921	-0.10083
0.0001	0.0020	0.0033	0.0074	0.1342
222	222	222	222	222

Spearman Rank Correlation, lake water chemistry by soil

Correlation Analysis

Spearman Correlation Coefficients / Prob > |R| under Ho: Rho=0 / Number of Observations

CANDLER

COLOR	FE	S04	TSS	HARD
-0.36718	-0.30115	0.27820	0.19661	0.15466
0.0001	0.0007	0.0018	0.0286	0.0863
124	124	124	124	124
ORTP	COND	NA	MG	TURB
0.15446	0.13487	-0.11836	0.11830	0.11454
0.0867	0.1353	0.1905	0.1907	0.2053
124	124	124	124	124

HONTOON

TURB	COLOR	SECCHI	TSS	ORTP
0.35634	0.32970	-0.29741	0.27870	0.27379
0.0048	0.0095	0.0210	0.0296	0.0328
61	61	60	61	61
TN	FTSI	NOX	CHLA	TKN
0.26420	0.25075	0.21029	0.20842	0.20072
0.0396	0.0513	0.1038	0.1070	0.1209
61	61	61	61	61

LAKE

TKN	TN	COLOR	CA	MG
-0.53664	-0.52514	-0.45662	0.33027	-0.29885
0.0019	0.0024	0.0098	0.0696	0.1024
31	31	31	31	31
TALK	TP	PH	CL	HARD
0.25455	0.23137	0.22811	-0.22670	0.20975
0.1670	0.2104	0.2171	0.2201	0.2574
31	31	31	31	31

MYAKKA

CL	NA	PH	COND	SECCHI
0.34673	0.31085	-0.18267	0.17316	0.13719
0.0001	0.0001	0.0234	0.0317	0.1048
154	154	154	154	141
S04	TSS	TALK	CHLA	K
0.13414	-0.11799	-0.10809	-0.10637	-0.09701
0.0972	0.1450	0.1821	0.1892	0.2314
154	154	154	154	154

PAOLA

NA	SECCHI	FTSI	CHLA	COLOR
-0.57145	0.54579	-0.54510	-0.51869	-0.50229
0.0023	0.0086	0.0040	0.0066	0.0089
26	22	26	26	26
TKN	TALK	PH	S04	TP
-0.50137	-0.47735	-0.43725	0.40622	-0.37972
0.0091	0.0137	0.0255	0.0439	0.0557
26	26	26	25	26

Spearman Rank Correlation, lake water chemistry by soil

Correlation Analysis

Spearman Correlation Coefficients / Prob > |R| under Ho: Rho=0 / Number of Observations

PLACID

NA	CL	PH	TALK	COND
-0.26919	-0.25307	-0.22144	-0.19114	-0.17108
0.0062	0.0103	0.0253	0.0543	0.0856
102	102	102	102	102
HARD	MG	CA	TKN	K
-0.15799	-0.15743	-0.13002	0.12805	-0.12342
0.1128	0.1141	0.1927	0.1996	0.2165
102	102	102	102	102

POMELLO

S04	K	MG	TSS	FE
0.16078	0.12750	0.11650	0.10799	-0.09975
0.1416	0.2449	0.2883	0.3253	0.3637
85	85	85	85	85
PH	CHLA	TALK	COLOR	TURB
0.09627	0.08638	-0.07778	-0.07758	0.07525
0.3808	0.4318	0.4792	0.4803	0.4937
85	85	85	85	85

POMONA

MG	TP	FE	SECCHI	TN
-0.20448	0.19856	0.18008	-0.16228	0.15972
0.1343	0.1462	0.1883	0.2652	0.2441
55	55	55	49	55
NA	HARD	COLOR	COND	ORTP
-0.15865	-0.15048	0.14739	-0.14618	0.12281
0.2473	0.2728	0.2829	0.2869	0.3717
55	55	55	55	55

POMPANO

S04	NA	CL	K	TN
-0.40266	-0.32312	-0.29008	-0.26266	-0.22472
0.0037	0.0221	0.0410	0.0654	0.1167
50	50	50	50	50
TKN	PH	COND	COLOR	FE
-0.21724	-0.20200	-0.18777	0.18413	0.17934
0.1297	0.1595	0.1916	0.2005	0.2127
50	50	50	50	50

SAMSULA

COLOR	NA	SECCHI	FE	S04
0.34046	0.21694	-0.17594	0.16791	-0.15613
0.0006	0.0310	0.0847	0.0967	0.1228
99	99	97	99	99
CL	HARD	TN	ORTP	CA
0.13550	-0.11421	-0.10180	0.10048	-0.09955
0.1811	0.2603	0.3160	0.3224	0.3269
99	99	99	99	99

Spearman Rank Correlation, lake water chemistry by soil

Correlation Analysis

Spearman Correlation Coefficients / Prob > |R| under Ho: Rho=0 / Number of Observations

SATELLITE

K	MG	S04	CL	HARD
-0.70353	-0.57570	-0.53827	-0.52014	-0.51272
0.0001	0.0001	0.0001	0.0001	0.0001
53	53	53	53	53
PH	COND	CA	NA	TALK
-0.43204	-0.38898	-0.37530	-0.34951	-0.33800
0.0012	0.0040	0.0056	0.0103	0.0133
53	53	53	53	53

SMYRNA

CHLA	MG	FTSI	K	TURB
-0.23644	-0.22963	-0.21688	-0.21375	-0.20453
0.0090	0.0113	0.0169	0.0186	0.0244
121	121	121	121	121
S04	HARD	TP	SECCHI	PH
-0.20372	-0.19164	-0.18976	0.18833	-0.18270
0.0250	0.0352	0.0371	0.0458	0.0449
121	121	121	113	121

SPARR

MG	CHLA	TSS	PH	FTSI
0.27418	0.21184	0.20649	0.18968	0.16881
0.0082	0.0426	0.0483	0.0702	0.1077
92	92	92	92	92
SECCHI	S04	K	FE	TURB
-0.16780	0.16010	0.14405	-0.14230	0.14149
0.1294	0.1274	0.1707	0.1760	0.1785
83	92	92	92	92

TAVARES

CL	MG	S04	TSS	NA
-0.27157	-0.23458	-0.22988	-0.22858	-0.21213
0.0002	0.0016	0.0020	0.0021	0.0045
178	178	178	178	178
TURB	CHLA	TP	K	TN
-0.19260	-0.18202	-0.17533	-0.17486	0.16878
0.0100	0.0150	0.0192	0.0196	0.0243
178	178	178	178	178

ZOLFO

TURB	TSS	SECCHI	FTSI	CHLA
-0.47758	-0.45982	0.40400	-0.37532	-0.34757
0.0001	0.0001	0.0001	0.0002	0.0006
95	95	89	95	95
NOX	PH	TP	MG	ORTP
0.34514	-0.31497	-0.31449	-0.30275	-0.29003
0.0006	0.0019	0.0019	0.0029	0.0044
95	95	95	95	95

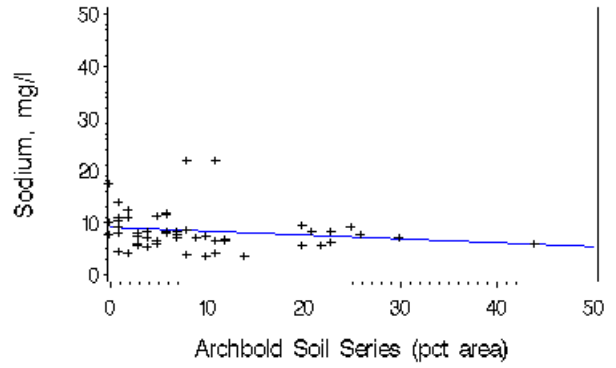
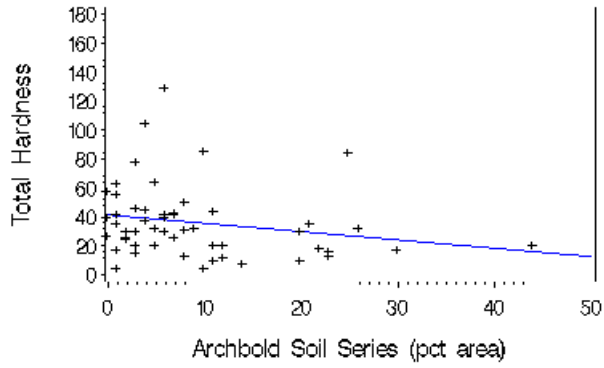
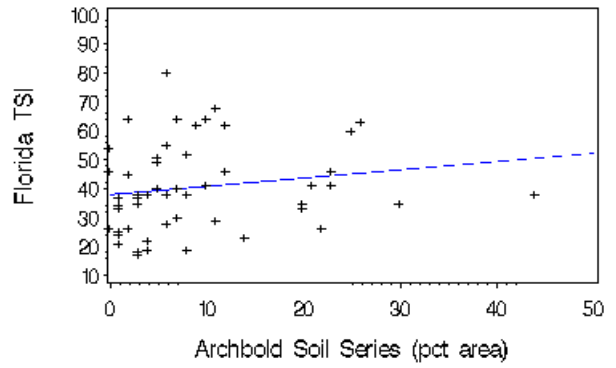
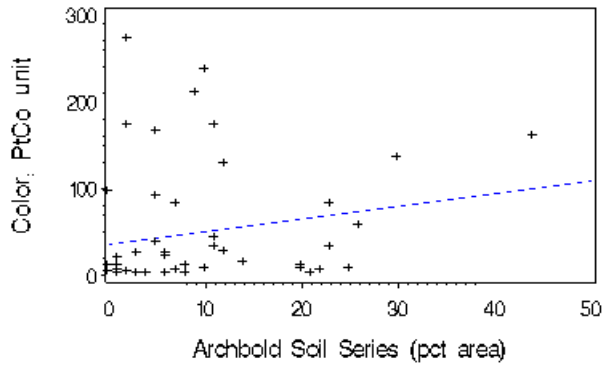
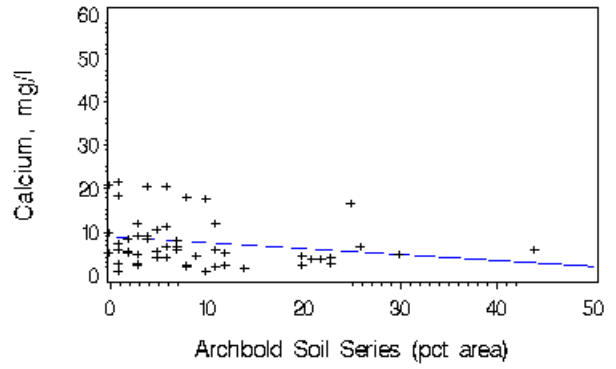
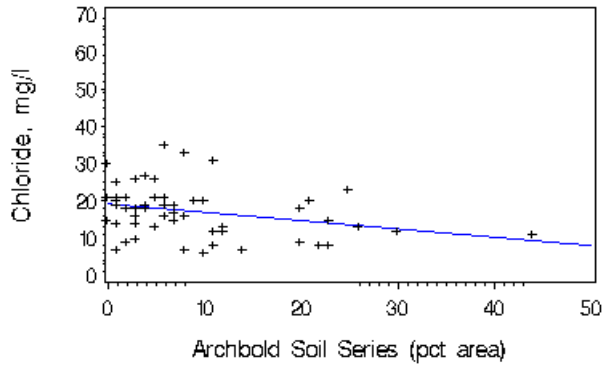
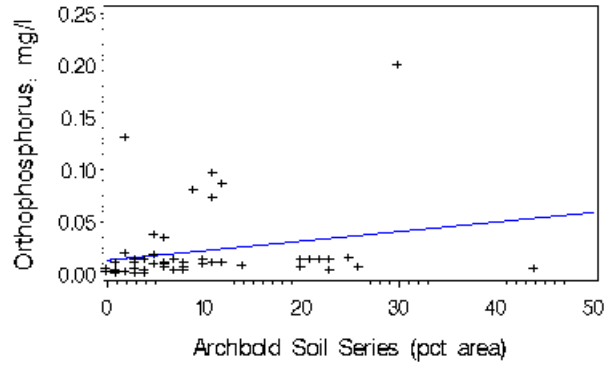
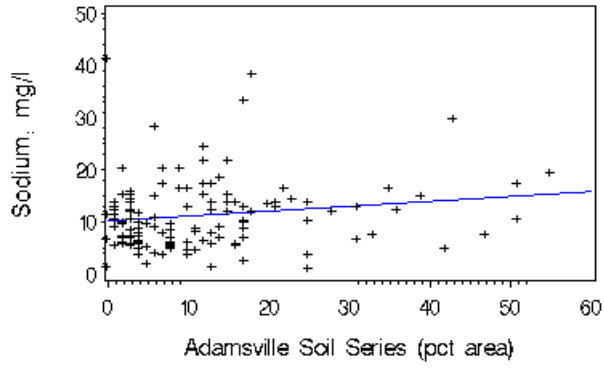

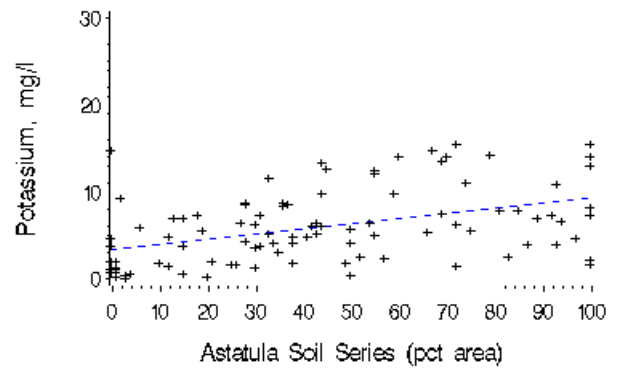
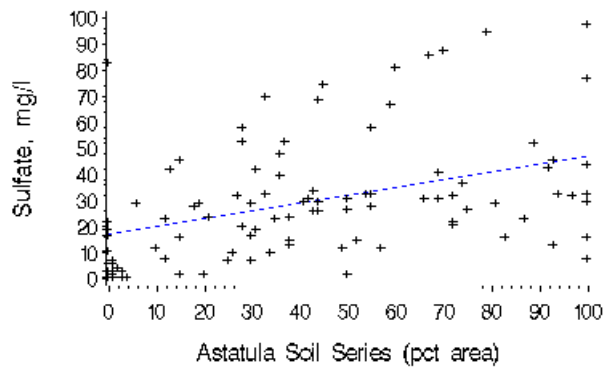
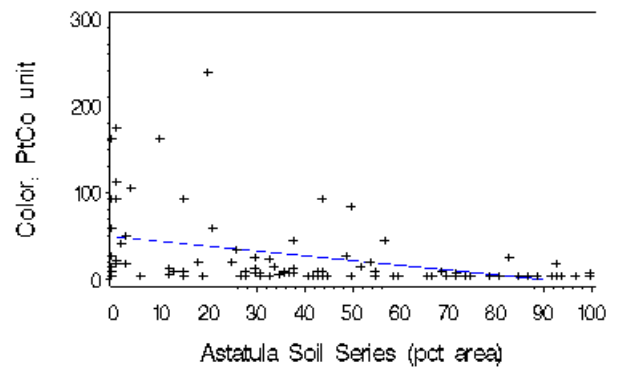
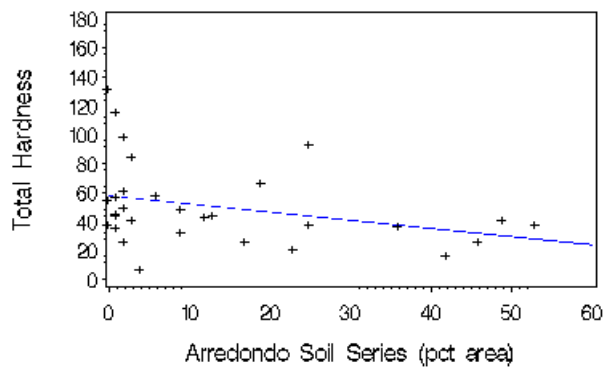
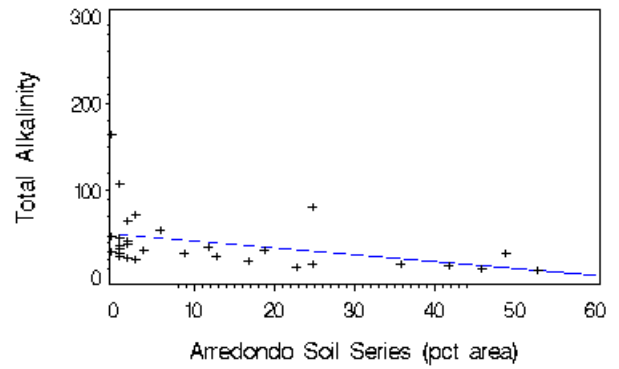
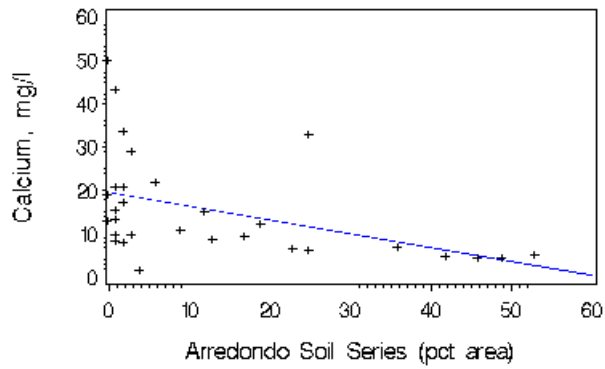
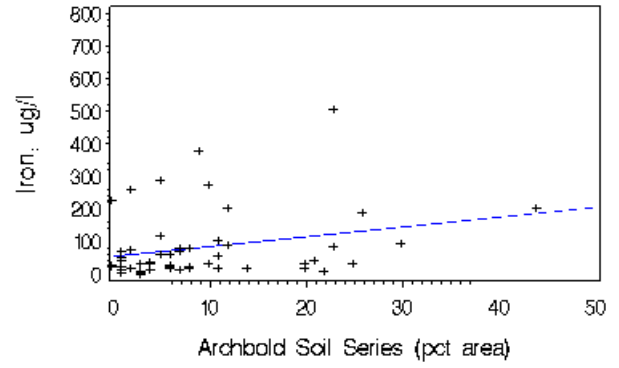
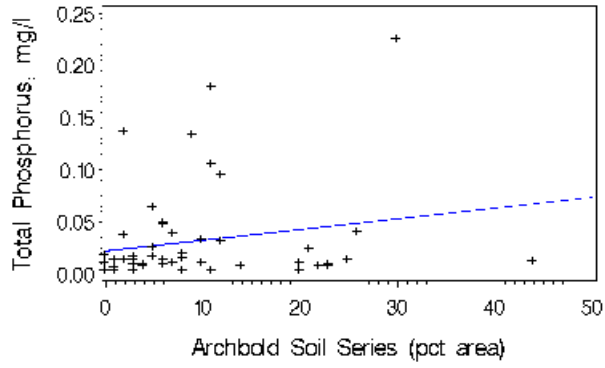

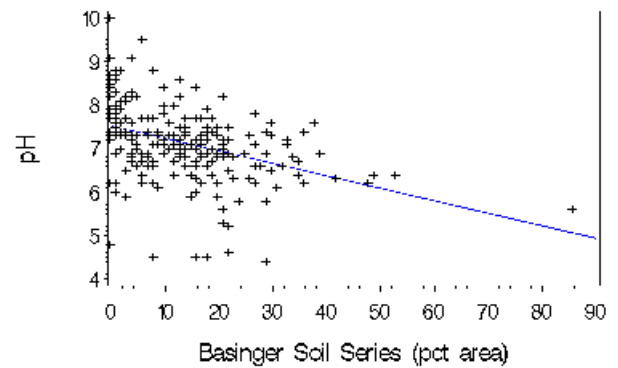
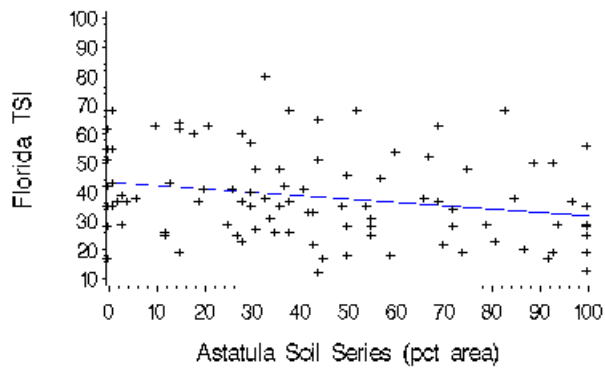
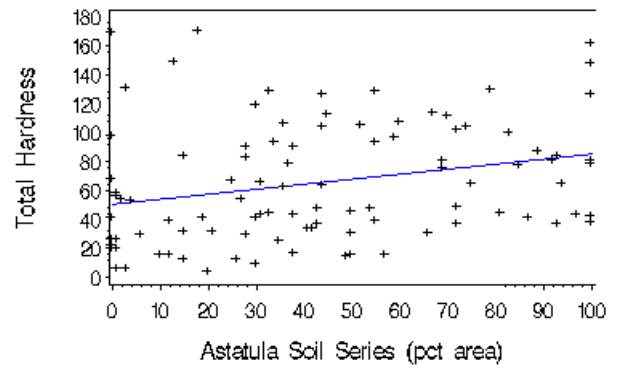
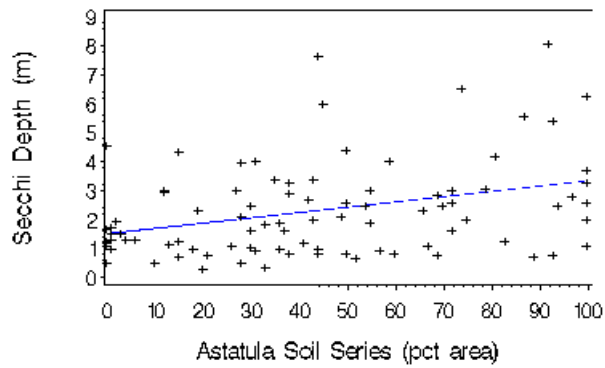
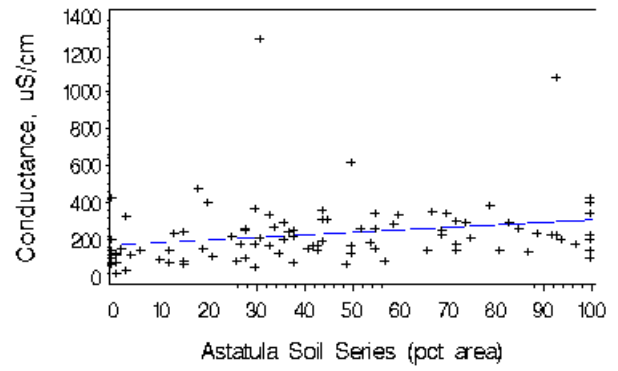
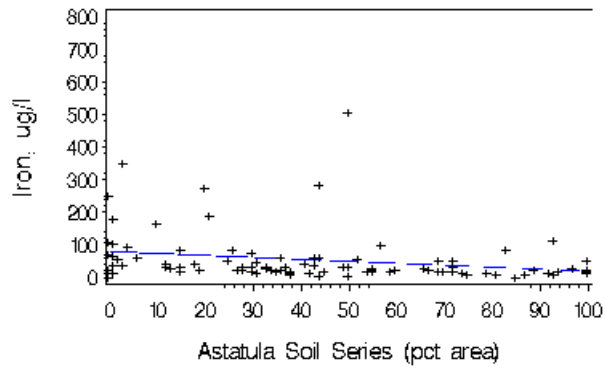
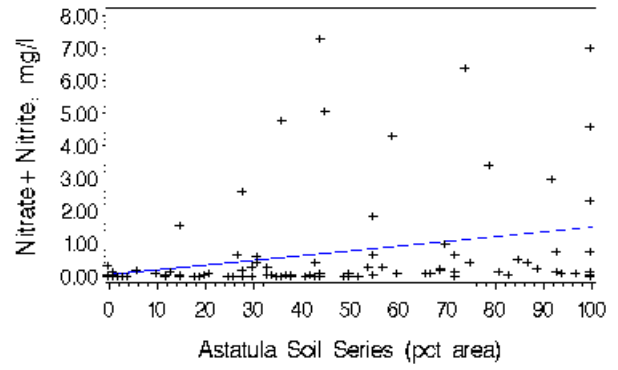
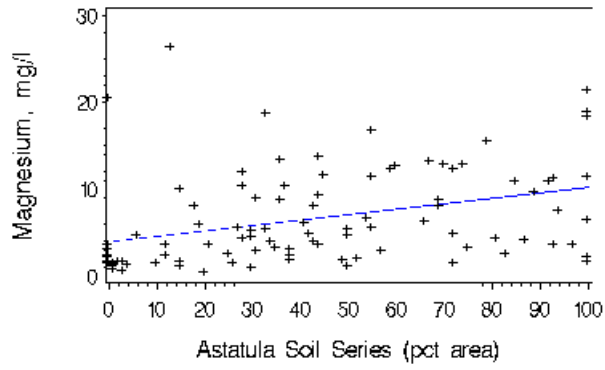

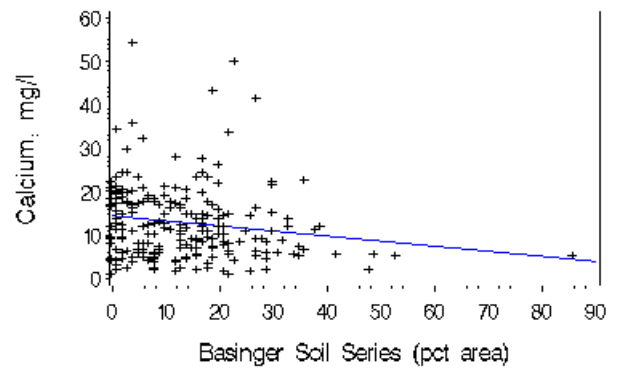
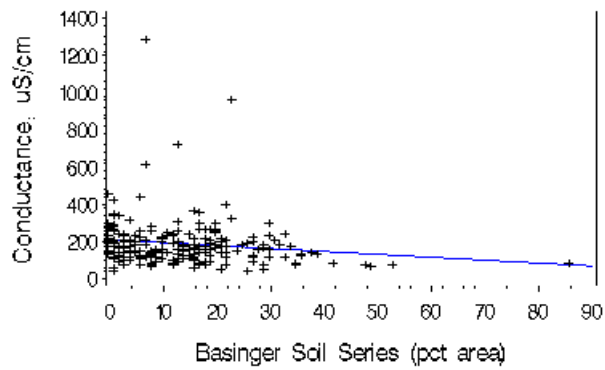
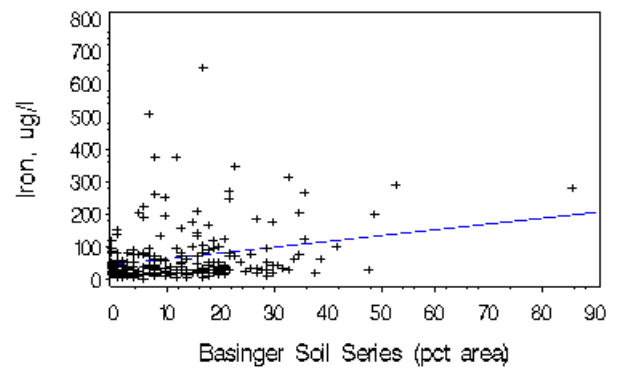
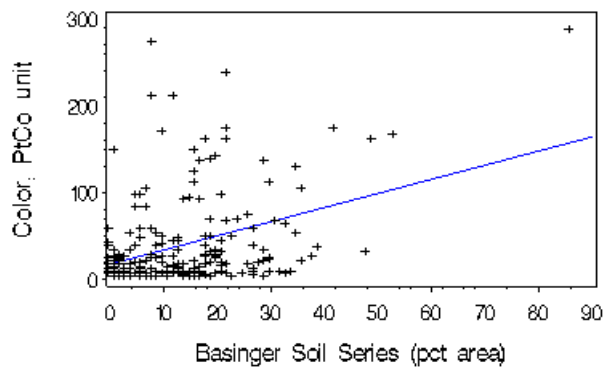
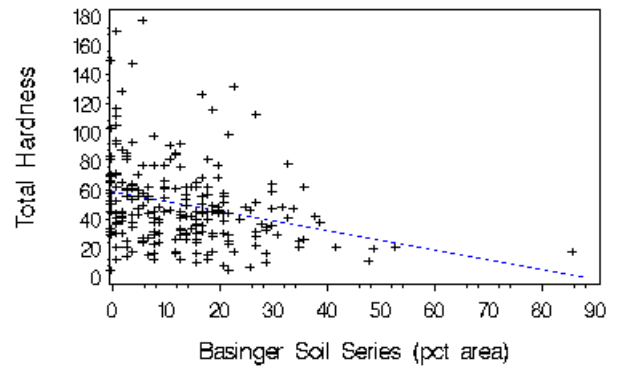
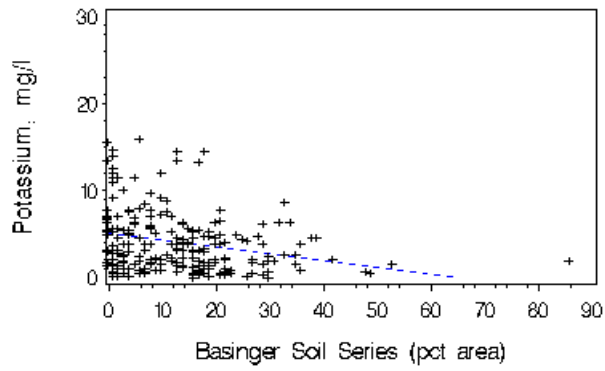
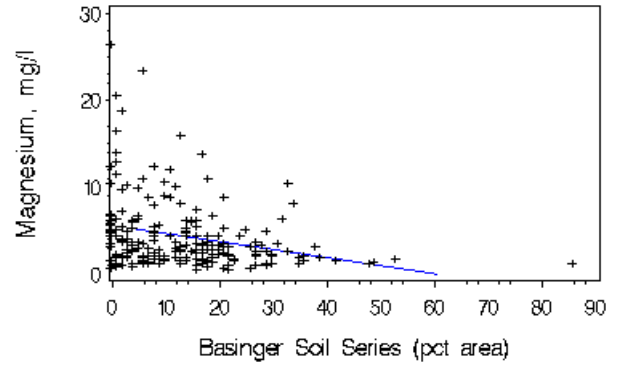
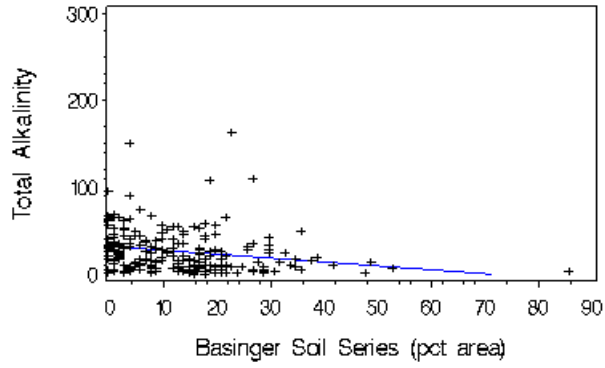

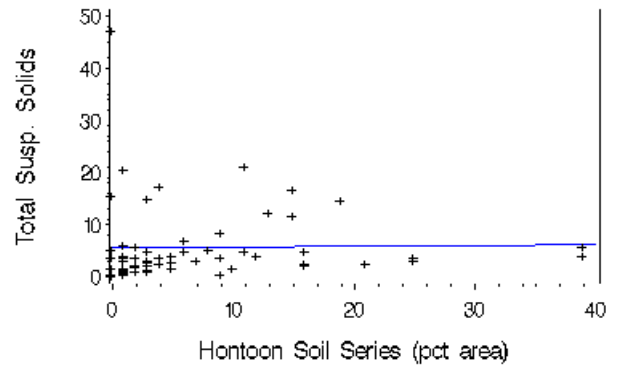
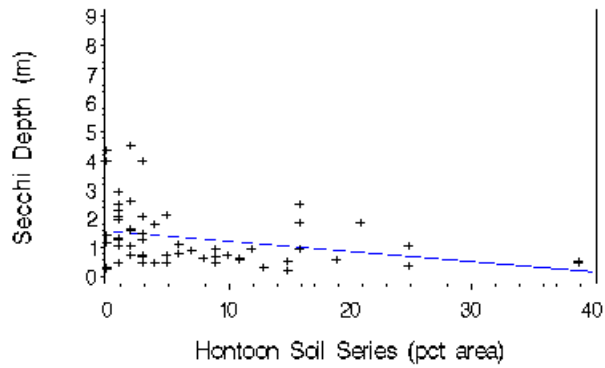
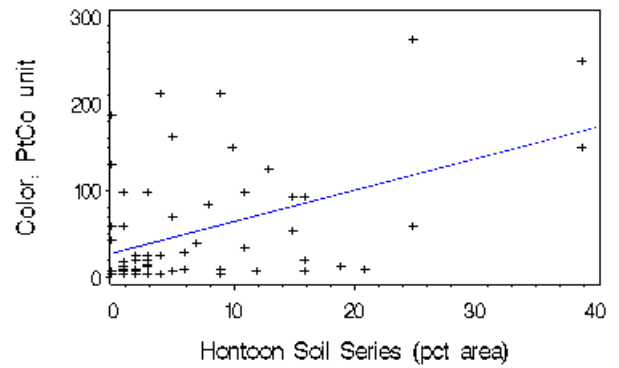
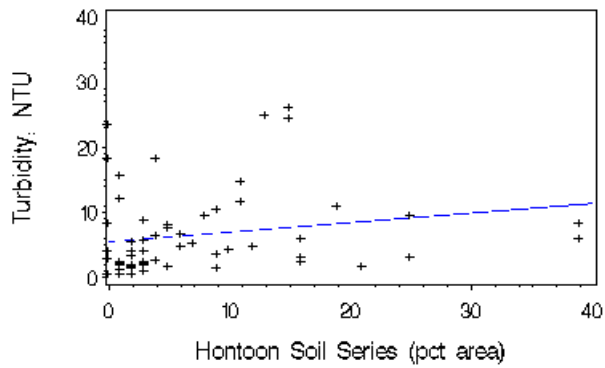
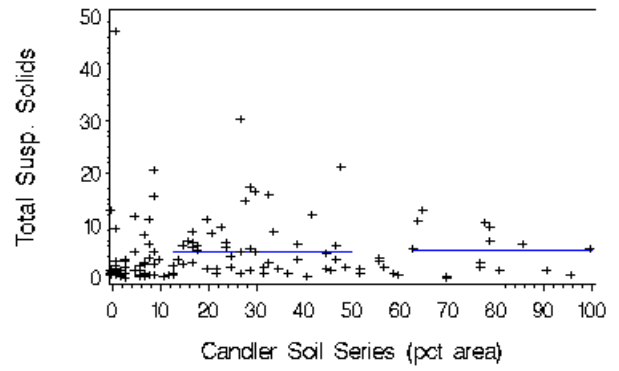
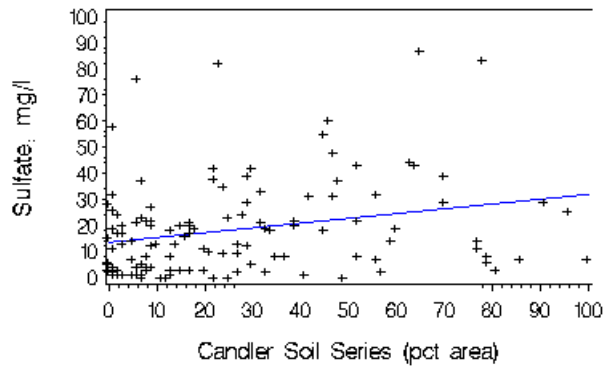
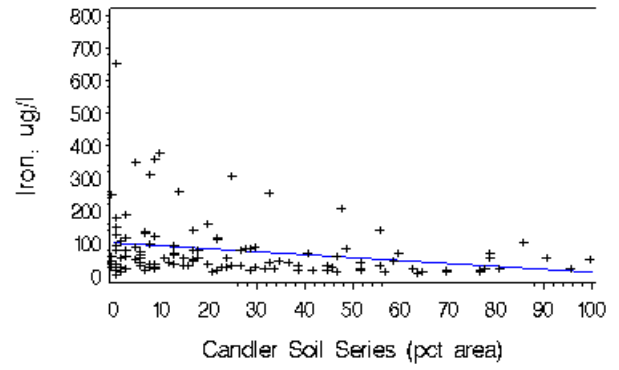
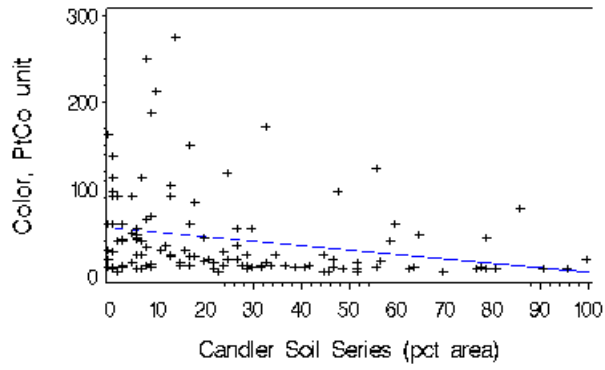

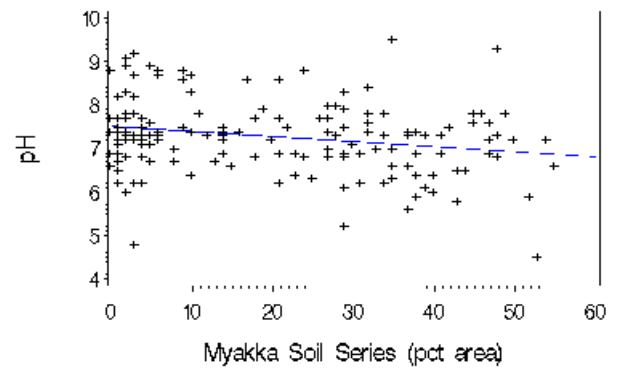
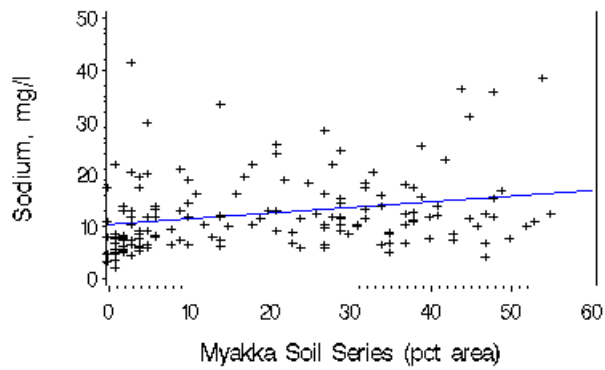
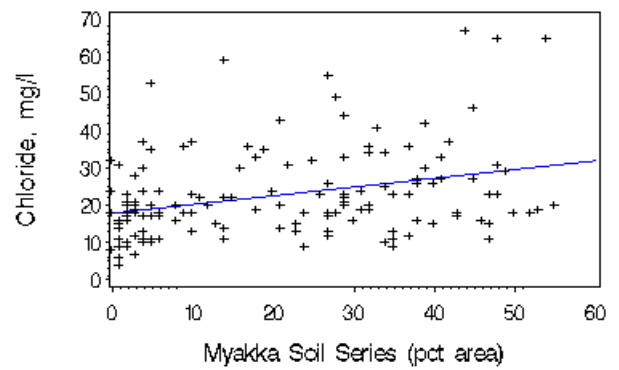
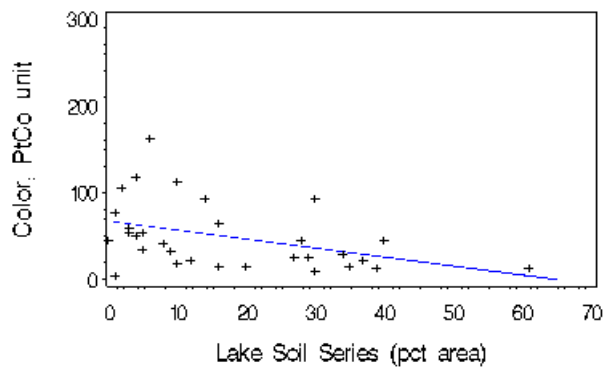
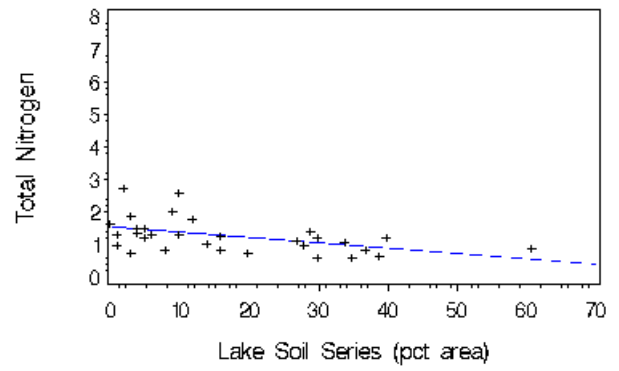
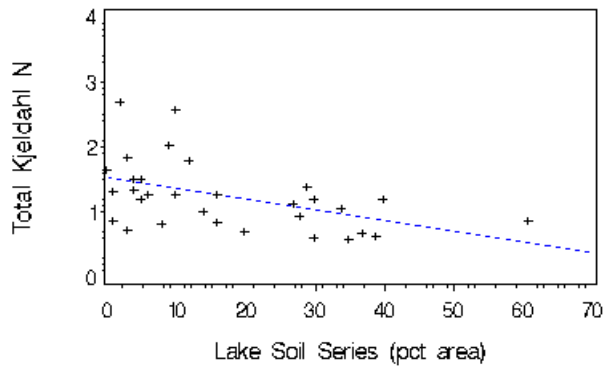
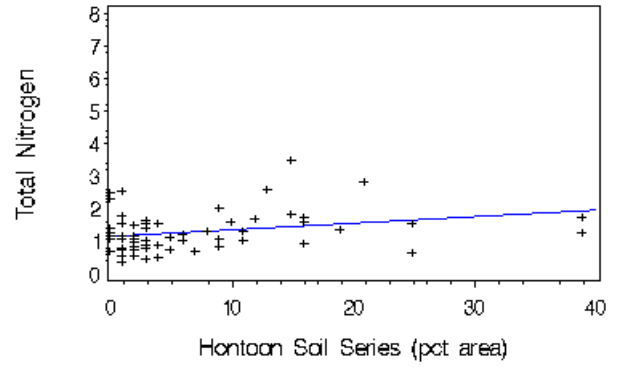
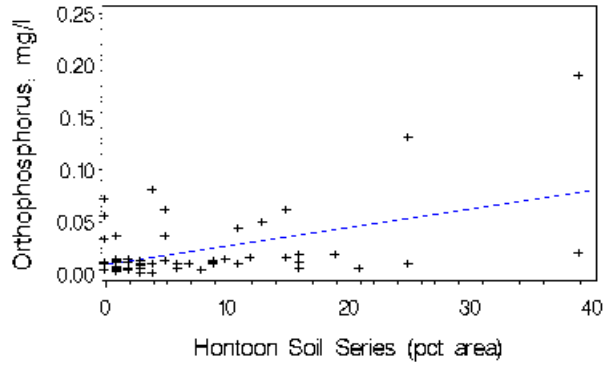

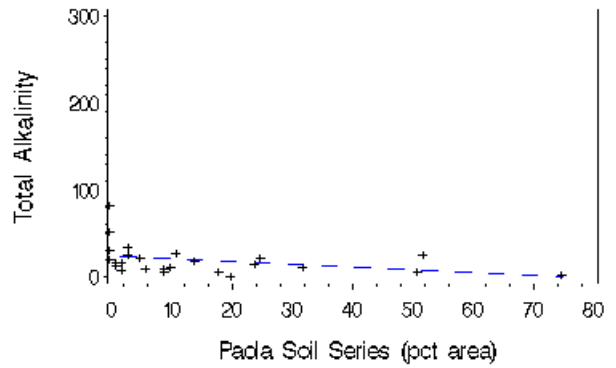
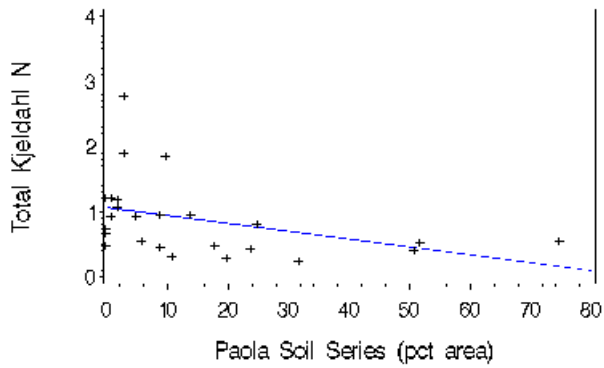
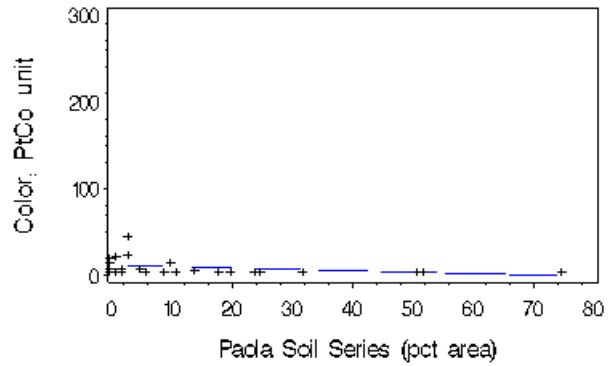
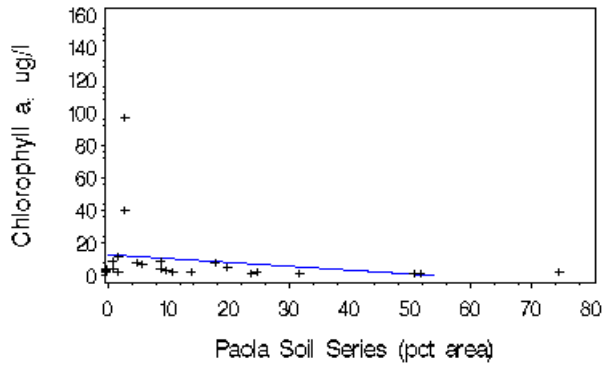
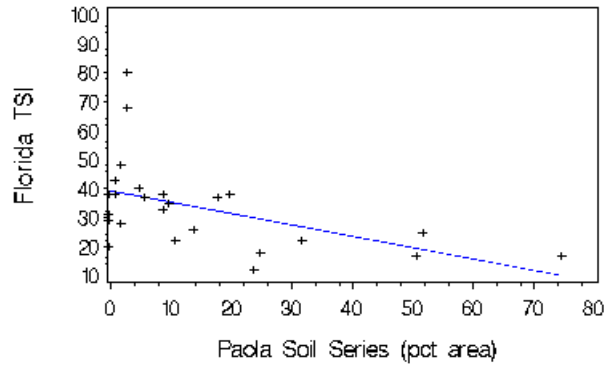
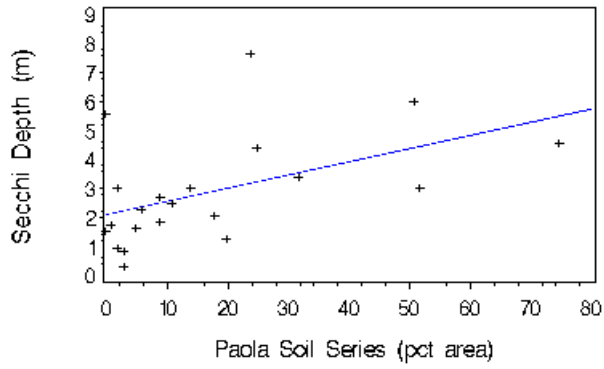
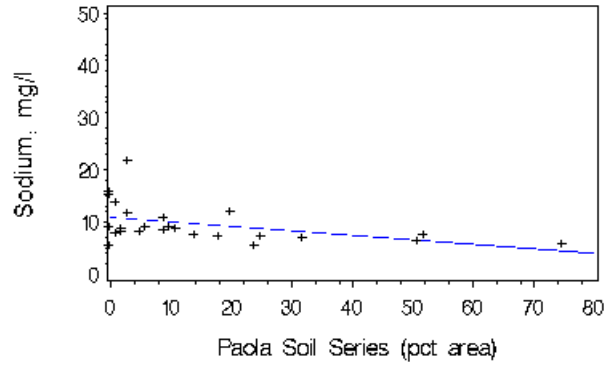
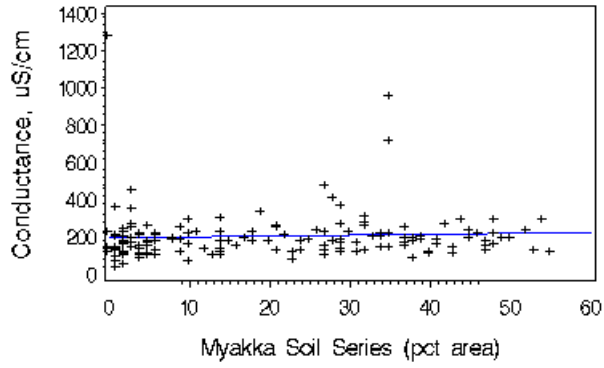

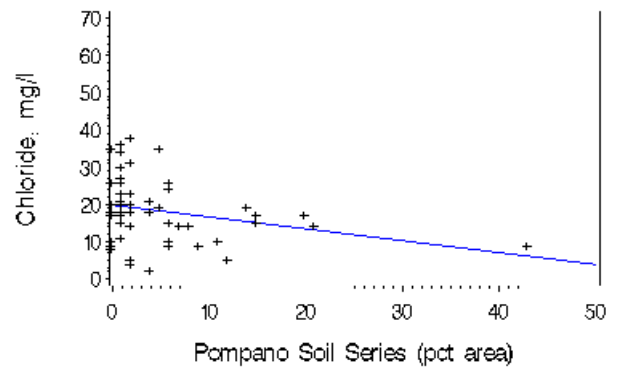
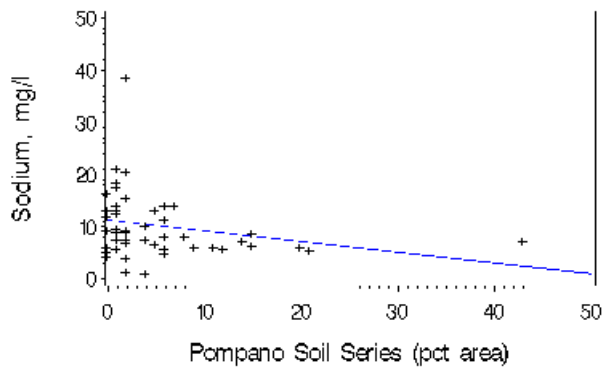
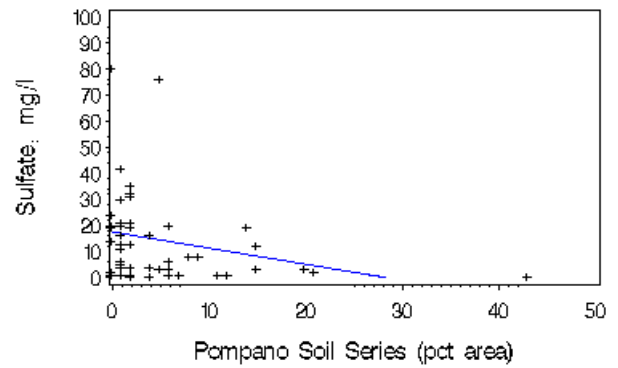
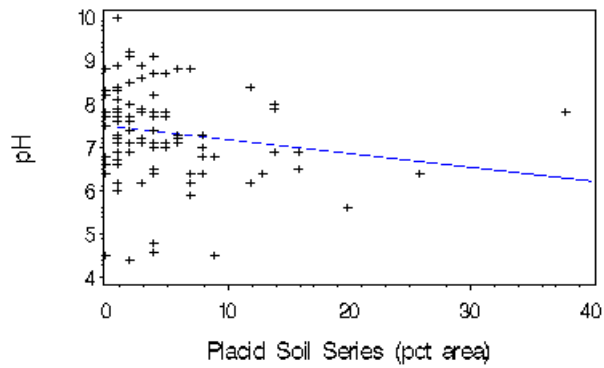
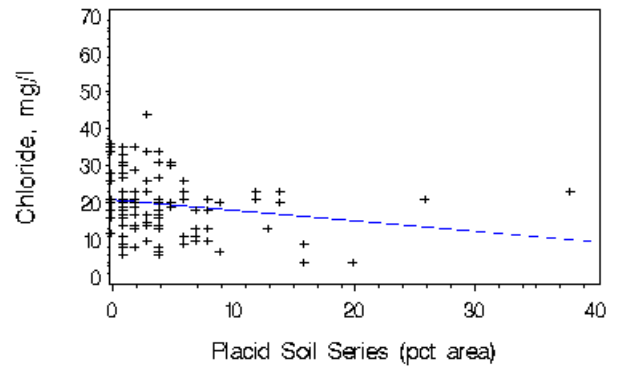
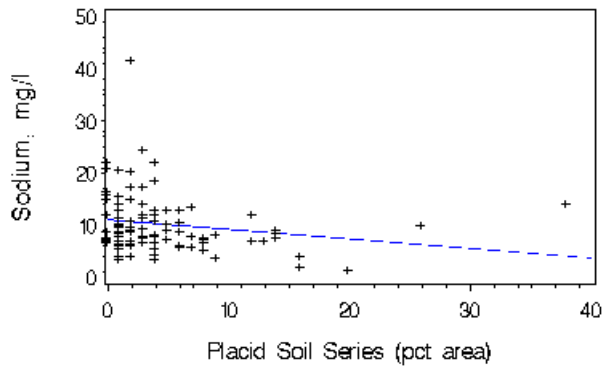
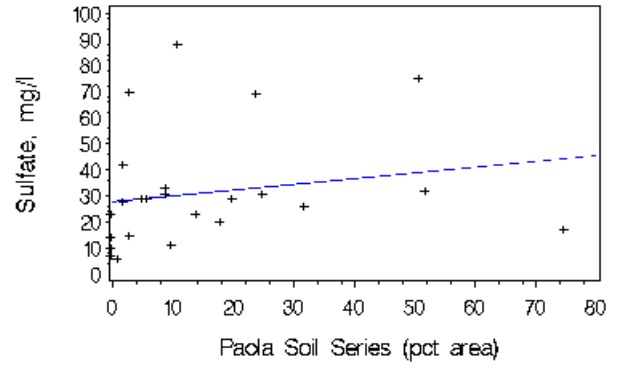
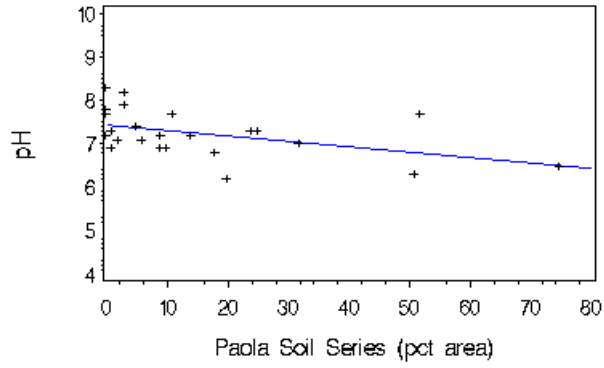

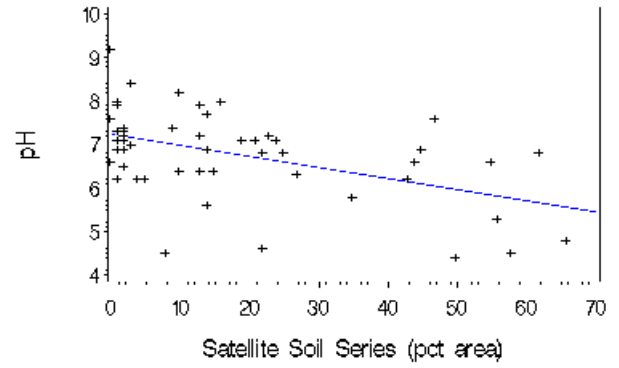
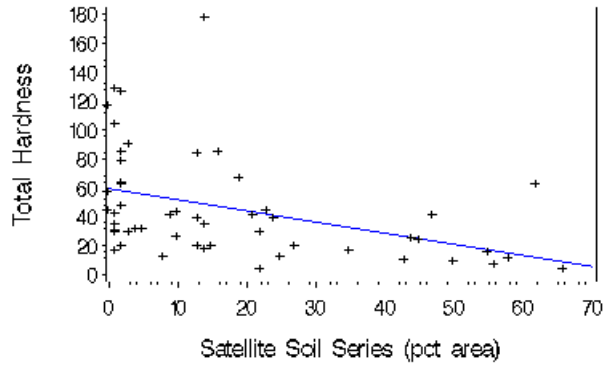
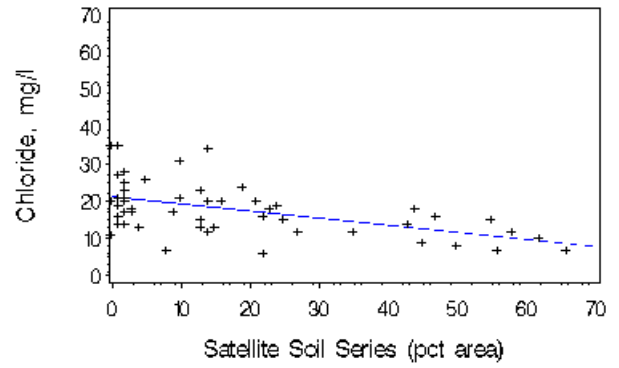
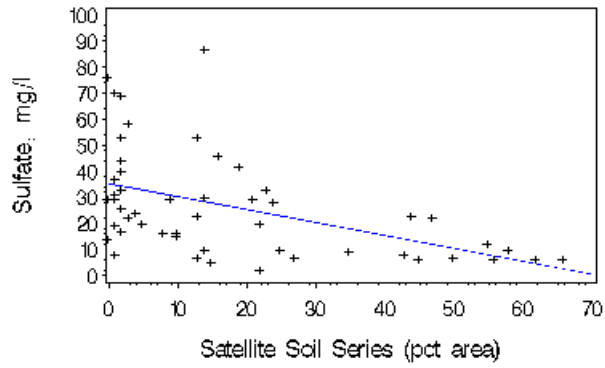
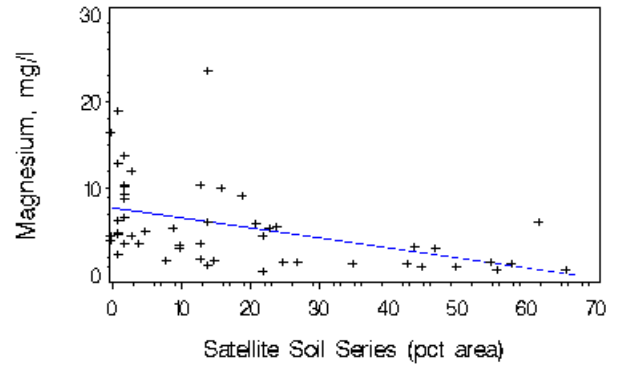
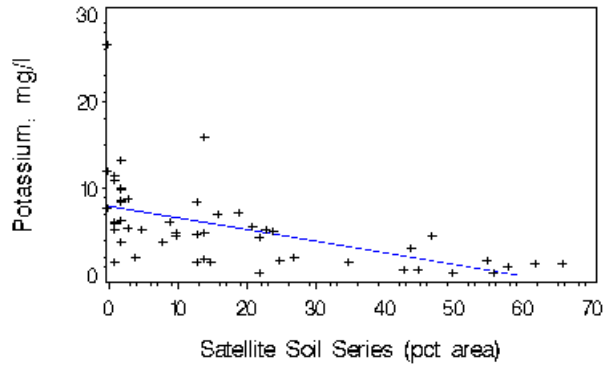
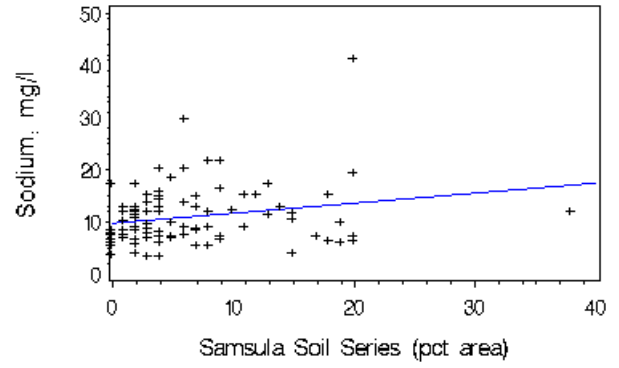
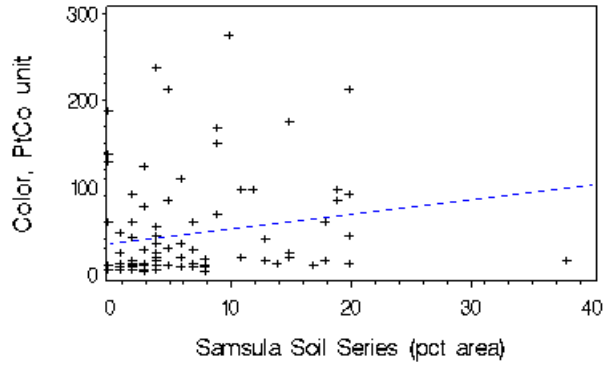

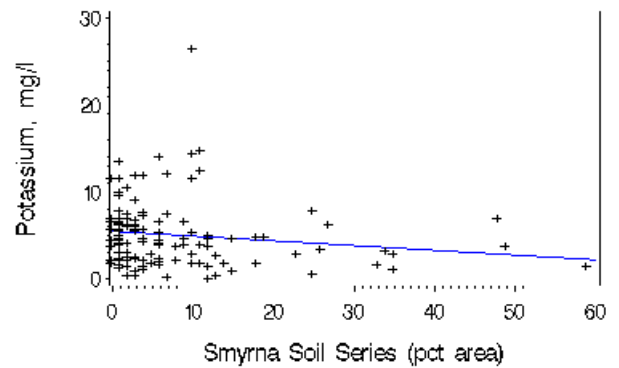
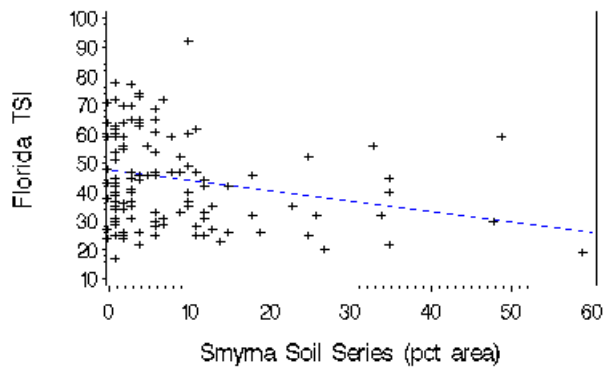
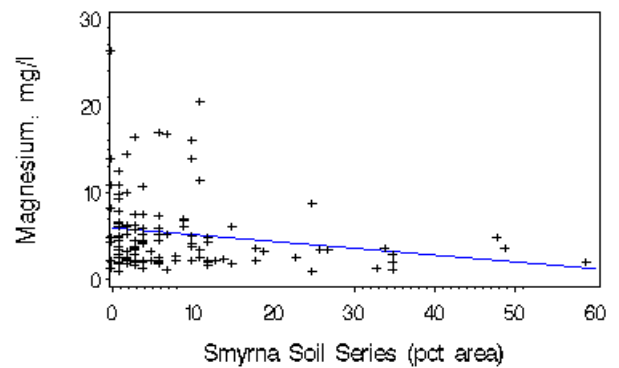
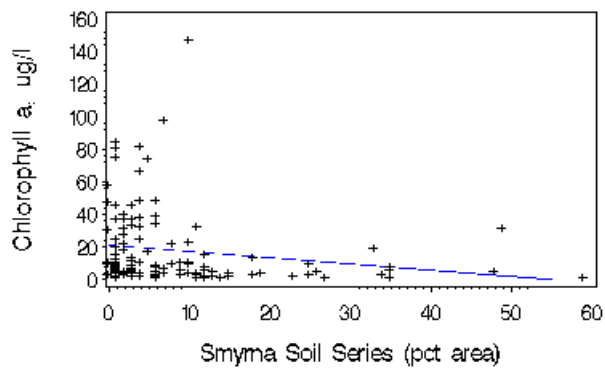
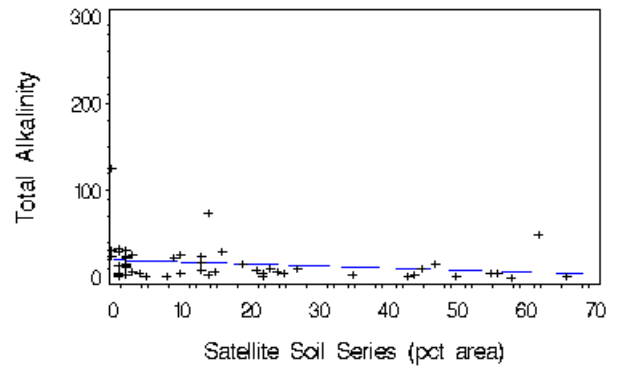
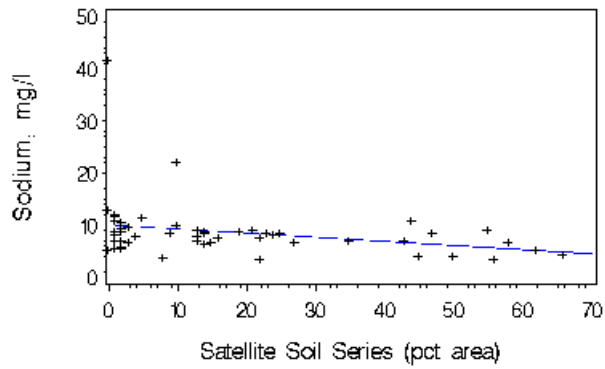
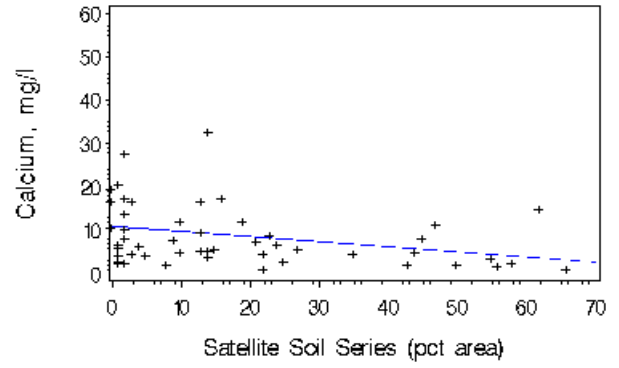
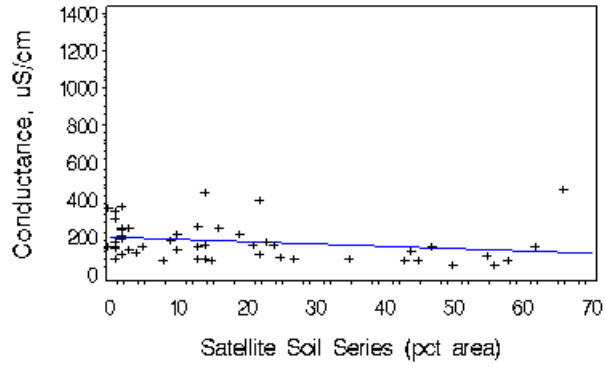

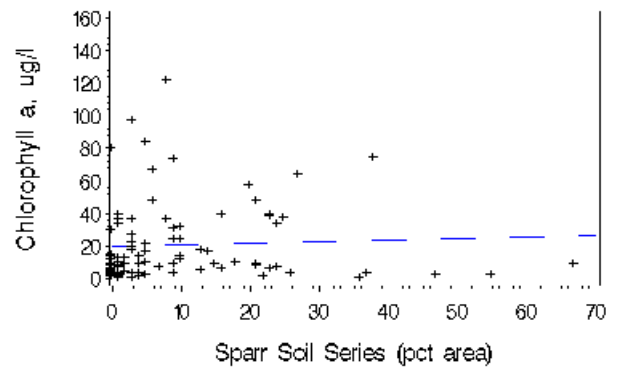
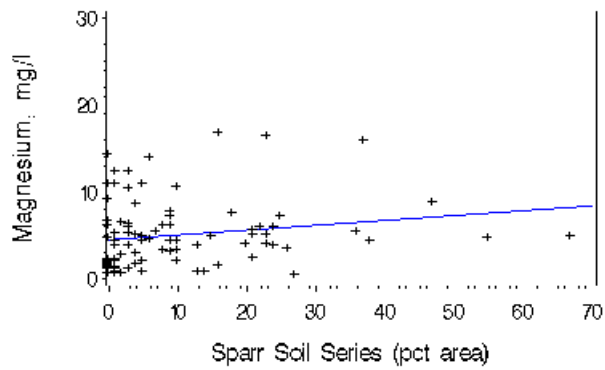
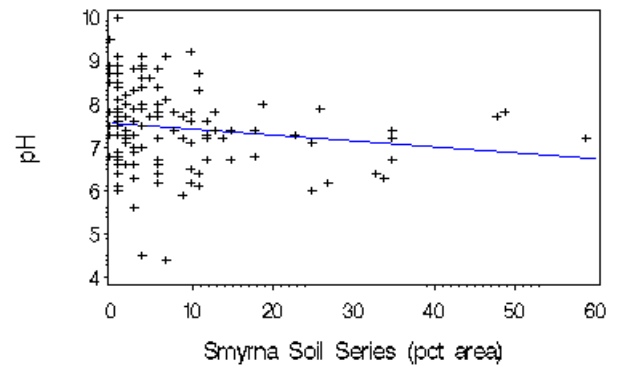
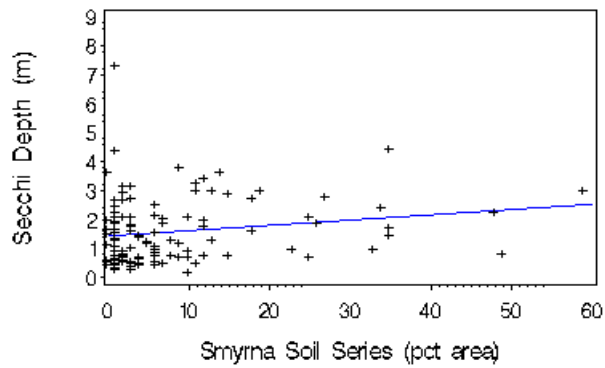
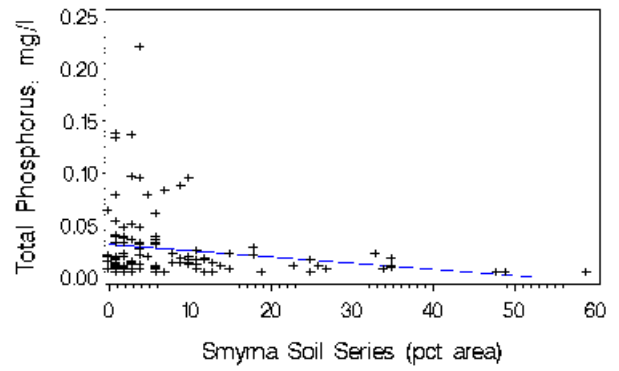
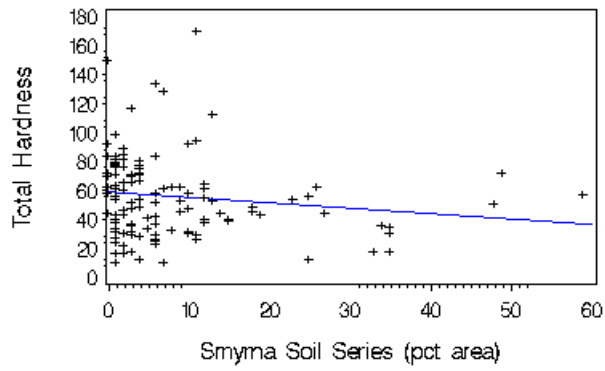
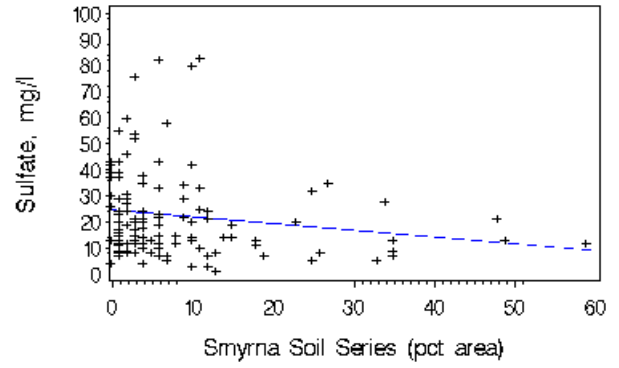
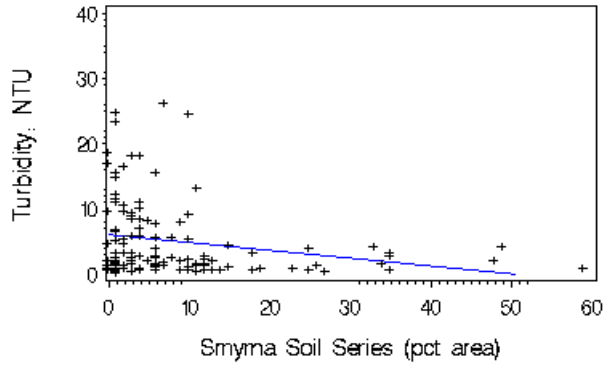

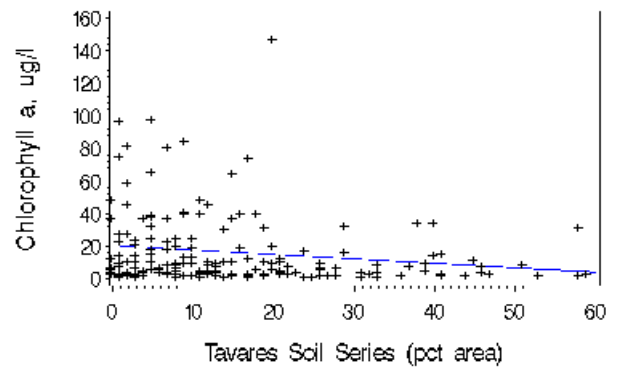
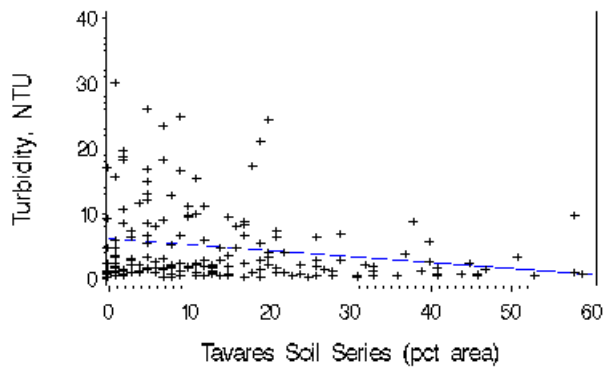
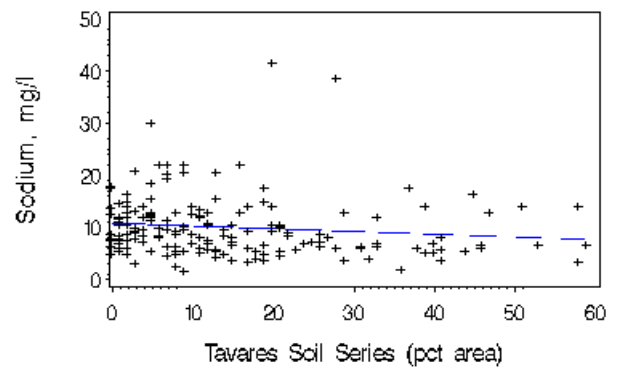
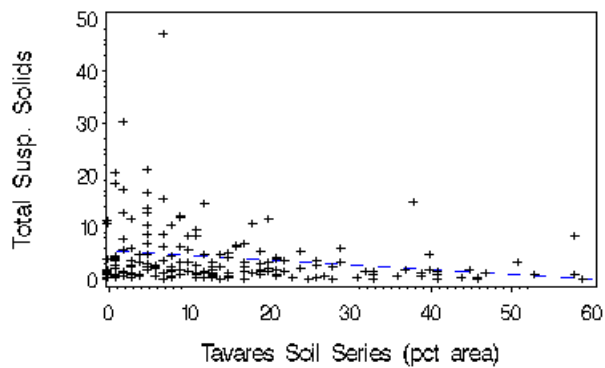
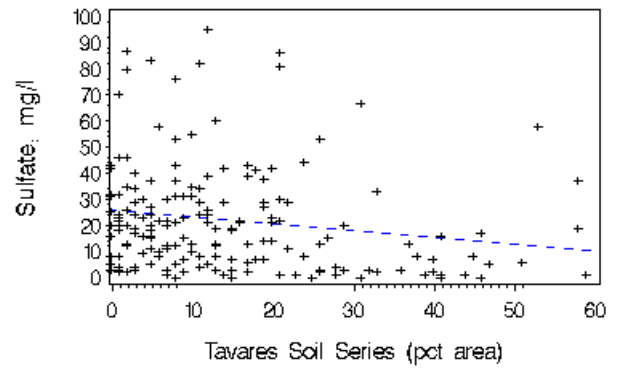
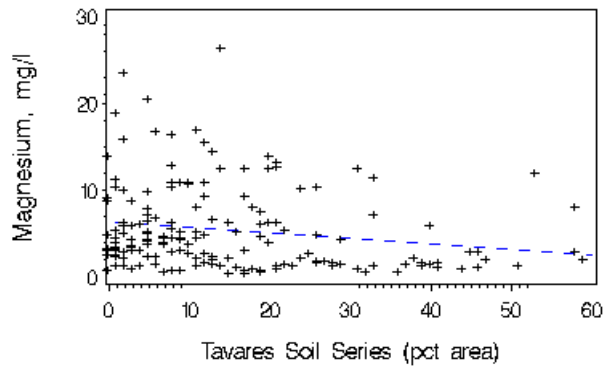
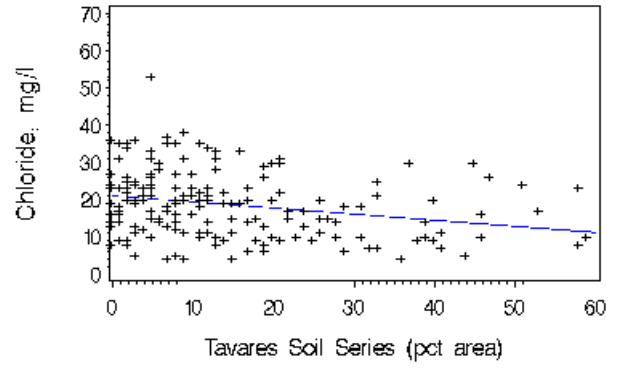
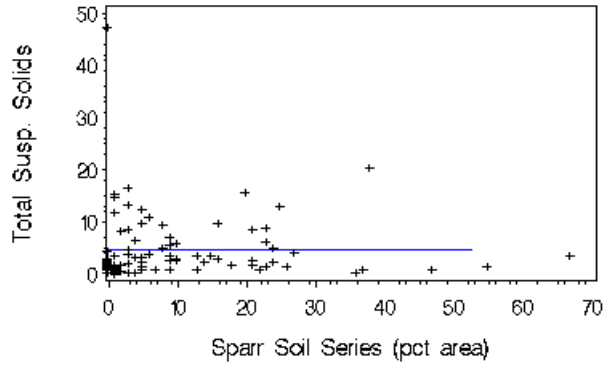

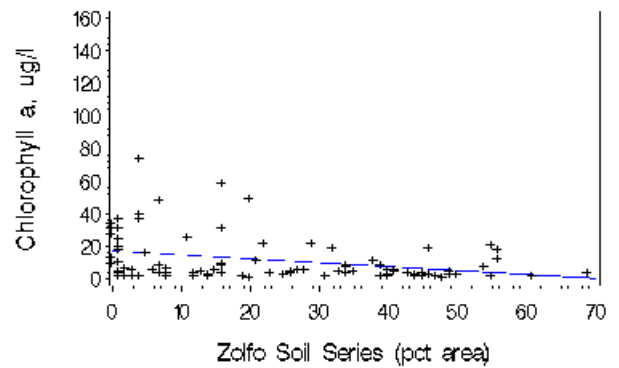
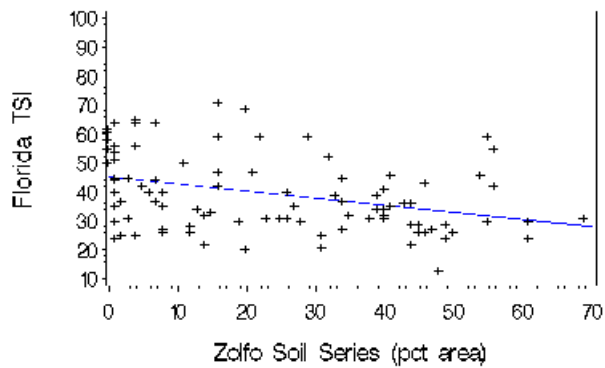
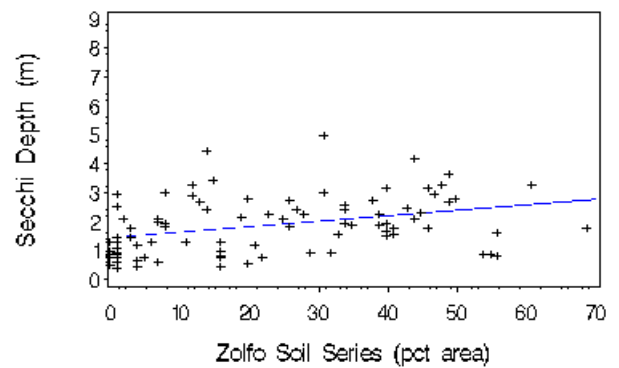
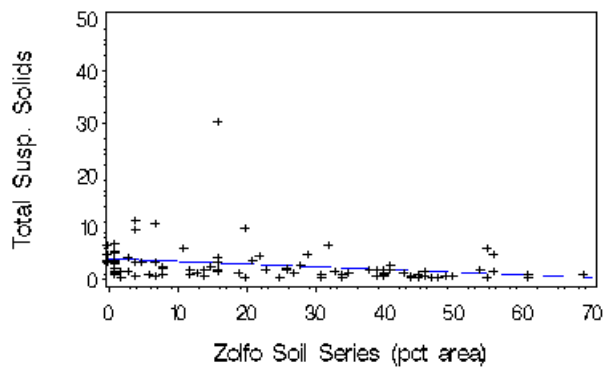
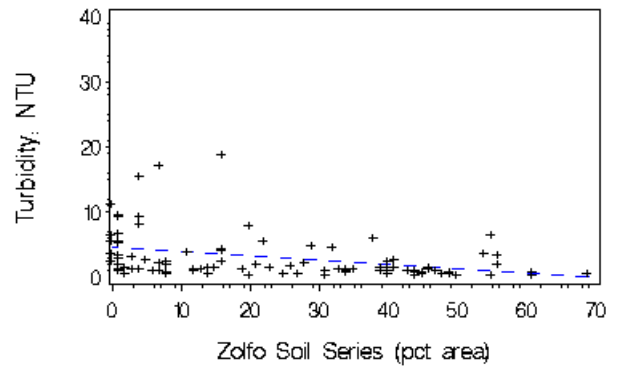
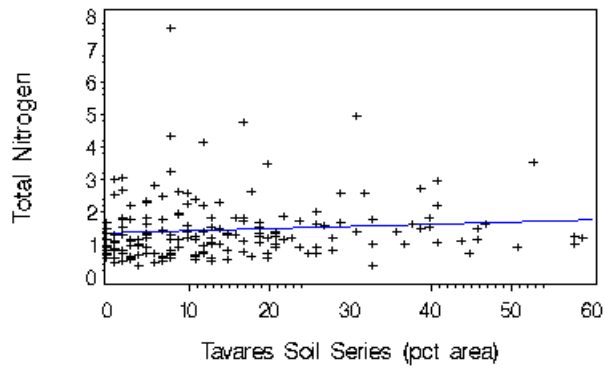
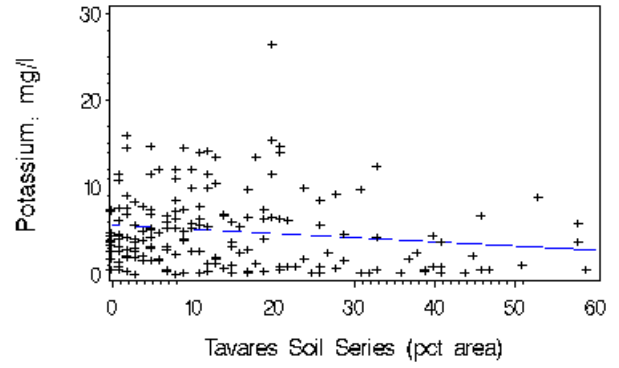
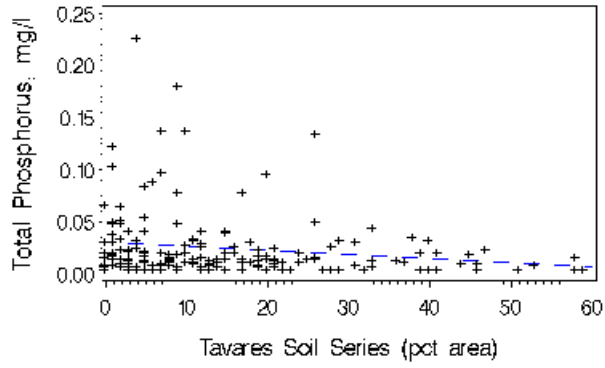

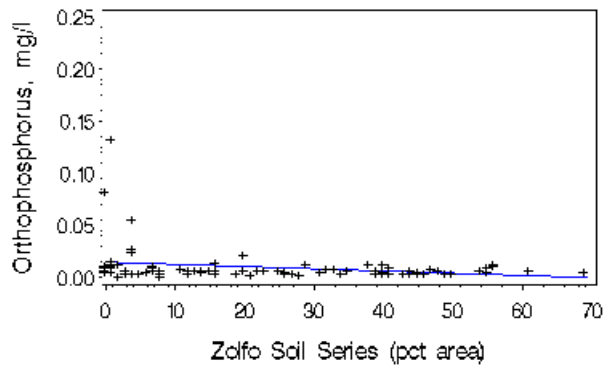
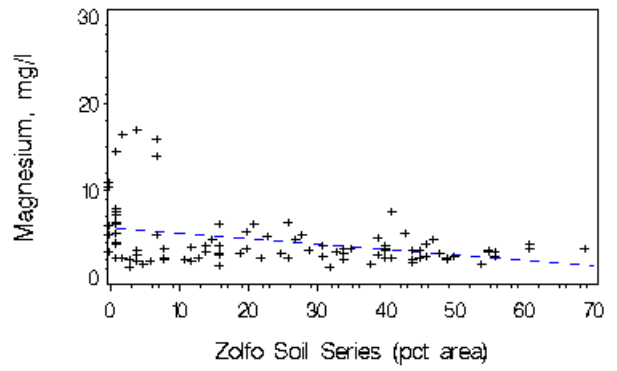
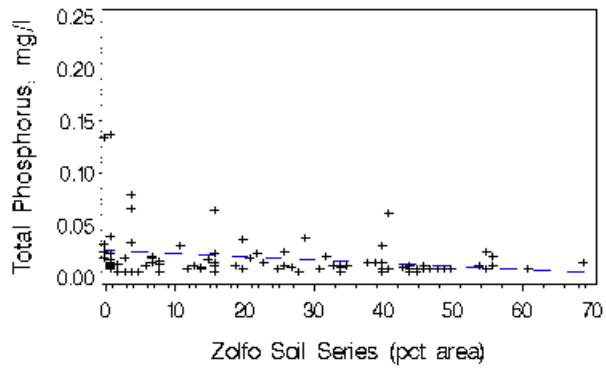
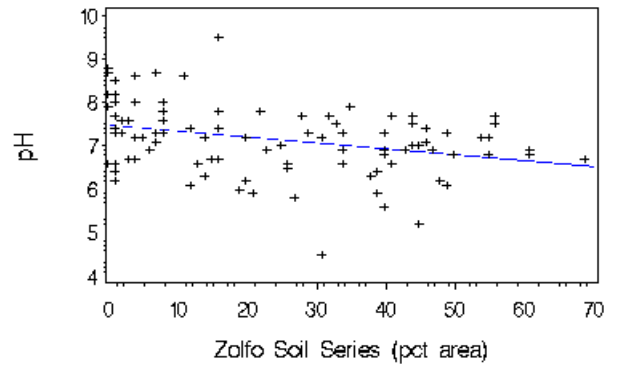
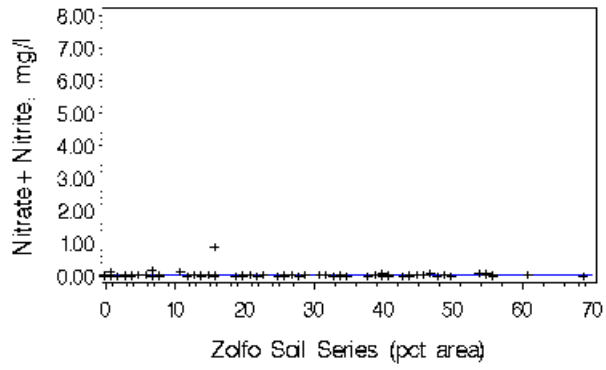

APPENDIX D

Lake Water Chemistry vs. Land Use, for 323 Sampled Lakes
in the Southwest Florida Water Management District.

APPENDIX D. Lake water chemistry vs. land use, for 323 sampled lakes in the Southwest Florida Water Management District.

Data to describe land use around each of the lakes were generated using GIS (Arc/Info). Lacking lake-specific drainage basin maps or coverages for each lake, it was assumed that the area immediately surrounding a lake was likely representative of land use within the drainage basin. Using the GIS, a 500 meter buffer was constructed around each lake. Within the buffer area, data were extracted from the GIS data base for land use. These data were reduced to percentages of each soil series of the total 500-meter buffer area.

Many land uses were not strongly represented in the data set, in other words, they were infrequently encountered around lakes or were of very limited surface area. Therefore, the data for correlations were further reduced by not calculating correlations for land uses represented within the 500 meter buffers of fewer than 37 lakes, or lakes having a range of total 500-meter buffer area coverage of less than 26 percent.

The correlations frequently suggest a relationship between land use and lake water chemistry. All of the significant correlations are plotted following the correlation summary pages. A regression line is shown on each plot to show the suggested relationship, however, the data for land use percent area and for water quality were not normally distributed which violates the normality assumption of regression statistics. The regression line is not significant.

It is important to note that for all correlations and plots in which coverage is expressed as a percentage, the remaining percentage is composed of another or perhaps several different land uses. These other land uses may have a greater, inverse influence on water chemistry than the land use for which the correlation is significant.

Abbreviations:

CA=calcium

CHLA=chlorophyll *a*

CL=chloride

COND=conductance

FE=iron

FTSI=Florida trophic state index

HARD=total hardness

K=potassium

MG=magnesium

NA=sodium

NOX=nitrate+nitrite

ORTP=orthophosphorus

PH=pH

SECCHI=transparency, Secchi depth

SO4=sulfate

TALK=total alkalinity

TKN=total Kjeldahl nitrogen

TN=total nitrogen

TP=total phosphorus

TSS=total suspended solids

TURB=turbidity

Spearman Rank Correlation, Lake Water Chemistry with Land Use

Correlation Analysis

18 'WITH' Variables: LU_1100 LU_1200 LU_1300 LU_1400 LU_1800 LU_1900 LU_2100 LU_2200
 LU_2600 LU_3200 LU_4100 LU_4110 LU_4120 LU_4340 LU_6210 LU_6410
 LU_6430 LU_8100
 22 'VAR' Variables: CA CHLA CL COLOR COND FE FTSI HARD
 K MG NA NOX ORTP PH SECCHI SO4
 TALK TKN TN TP TSS TURB

Simple Statistics

Variable	N	Mean	Std Dev	Median
LU_1100	236	11.716102	12.760974	7.000000
LU_1200	244	22.922131	17.585245	20.000000
LU_1300	142	15.852113	20.149423	6.000000
LU_1400	158	7.196203	7.881656	5.000000
LU_1800	78	6.320513	6.370577	4.000000
LU_1900	143	9.083916	12.754174	5.000000
LU_2100	214	14.948598	14.733698	10.000000
LU_2200	216	26.717593	25.410104	18.000000
LU_2600	153	10.209150	11.784609	6.000000
LU_3200	103	5.145631	5.767400	3.000000
LU_4100	56	6.964286	9.646411	3.000000
LU_4110	71	7.507042	9.551175	4.000000
LU_4120	37	9.756757	14.417207	5.000000
LU_4340	185	10.664865	13.939158	6.000000
LU_6210	92	5.673913	5.077658	4.000000
LU_6410	232	4.482759	5.732089	3.000000
LU_6430	68	3.588235	4.000878	2.000000
LU_8100	99	4.464646	4.543021	3.000000
CA	323	14.563467	9.805976	12.500000
CHLA	323	14.244892	20.659869	6.200000
CL	323	19.879257	10.559252	19.000000
COLOR	323	37.229102	50.100986	18.000000
COND	323	198.578947	128.021188	179.000000
FE	323	71.506811	98.260164	37.000000
FTSI	323	42.077399	15.815028	39.000000
HARD	323	56.117647	32.509221	48.000000
K	323	4.376471	3.892731	3.700000
MG	323	4.785449	4.280717	3.400000
NA	323	10.447368	6.335983	8.800000
NOX	323	0.250402	0.929763	0.019000
ORTP	323	0.014972	0.025885	0.008000
PH	323	7.293498	0.866915	7.300000
SECCHI	298	1.812685	1.319066	1.500000
SO4	322	21.046584	18.884821	16.000000
TALK	323	30.517028	28.271568	24.000000
TKN	323	1.166687	0.578932	1.070000
TN	323	1.416409	1.013862	1.190000
TP	323	0.026842	0.036621	0.014000
TSS	323	3.647988	4.984169	2.000000
TURB	323	4.090402	5.260157	2.000000

Spearman Rank Correlation, Lake Water Chemistry with Land Use

Simple Statistics

Variable	Minimum	Maximum	Label
LU_1100	1.000000	83.000000	Low Dens Residential (1100)
LU_1200	1.000000	77.000000	Med Dens Residential (1200)
LU_1300	1.000000	84.000000	High Dens Residential (1300)
LU_1400	1.000000	48.000000	Commercial & Services (1400)
LU_1800	1.000000	35.000000	Recreational (1800)
LU_1900	1.000000	80.000000	Open Land (1900)
LU_2100	1.000000	80.000000	Crop and Pasture (2100)
LU_2200	1.000000	100.000000	Tree Crops (2200)
LU_2600	1.000000	69.000000	Other Open Lands (2600)
LU_3200	1.000000	41.000000	Shrub & Brushland
LU_4100	1.000000	50.000000	Upland Coniferous Forest (4100)
LU_4110	1.000000	61.000000	Pine Flatwoods (4110)
LU_4120	1.000000	72.000000	Longleaf Pine-Xeric Oak (4120)
LU_4340	1.000000	84.000000	Hardwood-Conifer Mixed (4340)
LU_6210	1.000000	30.000000	Cypress (6210)
LU_6410	1.000000	53.000000	Freshwater Marshes (6410)
LU_6430	1.000000	27.000000	Wet Prairies (6430)
LU_8100	1.000000	29.000000	Transportation (8100)
CA	1.000000	55.000000	Calcium, mg/l
CHLA	1.000000	146.800000	Chlorophyll a, ug/l
CL	2.000000	67.000000	Chloride, mg/l
COLOR	4.000000	289.000000	Color, PtCo unit
COND	25.000000	1284.000000	Conductance, uS/cm
FE	0	773.500000	Iron, ug/l
FTSI	12.000000	92.000000	Florida TSI
HARD	5.000000	178.000000	Total Hardness
K	0	26.500000	Potassium, mg/l
MG	0.500000	26.400000	Magnesium, mg/l
NA	1.100000	41.500000	Sodium, mg/l
NOX	0.005000	7.313000	Nitrate+Nitrite, mg/l
ORTP	0	0.208000	Orthophosphorus, mg/l
PH	4.400000	10.000000	pH
SECCHI	0.200000	8.050000	Secchi Depth (m)
SO4	0	98.000000	Sulfate, mg/l
TALK	0	217.000000	Total Alkalinity
TKN	0.120000	3.410000	Total Kjeldahl N
TN	0.310000	7.750000	Total Nitrogen
TP	0.005000	0.230000	Total Phosphorus, mg/l
TSS	0	47.200000	Total Susp. Solids
TURB	0.100000	31.900000	Turbidity, NTU

Spearman Rank Correlation, Lake Water Chemistry with Land Use

Correlation Analysis

Spearman Correlation Coefficients / Prob > |R| under Ho: Rho=0 / Number of Observations

LU_1100					
Low Dens Residential (1100)	COND	MG	K	S04	CL
	-0.26589	-0.24430	-0.23013	-0.20879	-0.18288
	0.0001	0.0002	0.0004	0.0013	0.0048
	236	236	236	235	236
	COLOR	HARD	NA	FE	FTSI
	0.17687	-0.16899	-0.14425	0.12840	0.07648
	0.0064	0.0093	0.0267	0.0488	0.2419
	236	236	236	236	236
LU_1200					
Med Dens Residential (1200)	COLOR	TN	SECCHI	NA	FE
	-0.24222	-0.21001	0.18113	0.17052	-0.16134
	0.0001	0.0010	0.0061	0.0076	0.0116
	244	244	228	244	244
	ORTP	TKN	TP	FTSI	PH
	-0.15978	-0.15597	-0.12913	-0.09298	0.07921
	0.0125	0.0147	0.0439	0.1476	0.2176
	244	244	244	244	244
LU_1300					
High Dens Residential (1300)	MG	K	CA	TALK	TP
	-0.35428	-0.30961	0.28930	0.23594	0.22870
	0.0001	0.0002	0.0005	0.0047	0.0062
	142	142	142	142	142
	SECCHI	FE	FTSI	S04	NOX
	-0.21230	0.15884	0.15529	-0.14211	-0.13019
	0.0149	0.0590	0.0650	0.0916	0.1225
	131	142	142	142	142
LU_1400					
Commercial & Services (1400)	TALK	CA	PH	CHLA	TP
	0.35993	0.34198	0.33706	0.28665	0.25527
	0.0001	0.0001	0.0001	0.0003	0.0012
	158	158	158	158	158
	HARD	FTSI	TURB	SECCHI	COND
	0.25011	0.24388	0.22577	-0.20907	0.19422
	0.0015	0.0020	0.0043	0.0105	0.0145
	158	158	158	149	158
LU_1800					
Recreational (1800)	ORTP	MG	CHLA	K	TSS
	0.23469	0.20828	0.19165	0.18228	0.18110
	0.0386	0.0673	0.0928	0.1102	0.1126
	78	78	78	78	78
	COND	TURB	HARD	FTSI	CL
	0.16683	0.16123	0.15803	0.14580	0.13054
	0.1443	0.1585	0.1670	0.2028	0.2546
	78	78	78	78	78

Spearman Rank Correlation, Lake Water Chemistry with Land Use

Correlation Analysis

Spearman Correlation Coefficients / Prob > |R| under Ho: Rho=0 / Number of Observations

LU_1900					
Open Land (1900)	NA	CL	K	HARD	MG
	-0.41195	-0.37956	-0.30957	-0.30937	-0.27661
	0.0001	0.0001	0.0002	0.0002	0.0008
	143	143	143	143	143
	FE	S04	CA	COLOR	SECCHI
	0.27583	-0.26507	-0.26475	0.26440	-0.25646
	0.0009	0.0014	0.0014	0.0014	0.0031
	143	143	143	143	131
LU_2100					
Crop and Pasture (2100)	SECCHI	COLOR	FTSI	TKN	FE
	-0.27172	0.25258	0.22791	0.21185	0.18679
	0.0001	0.0002	0.0008	0.0018	0.0061
	198	214	214	214	214
	TN	TP	S04	TURB	CHLA
	0.18439	0.18116	-0.17749	0.16955	0.16119
	0.0068	0.0079	0.0093	0.0130	0.0183
	214	214	214	214	214
LU_2200					
Tree Crops (2200)	MG	K	S04	NOX	COLOR
	0.67747	0.64157	0.58277	0.46739	-0.38621
	0.0001	0.0001	0.0001	0.0001	0.0001
	216	216	215	216	216
	COND	HARD	FE	ORTP	CL
	0.35954	0.31324	-0.26625	0.23673	0.22340
	0.0001	0.0001	0.0001	0.0004	0.0009
	216	216	216	216	216
LU_2600					
Other Open Lands (2600)	CA	TALK	HARD	NOX	CHLA
	-0.22091	-0.20452	-0.14617	0.13762	-0.13342
	0.0061	0.0112	0.0714	0.0898	0.1002
	153	153	153	153	153
	PH	S04	MG	FTSI	TP
	-0.11038	0.10284	0.10218	-0.08976	-0.08907
	0.1744	0.2074	0.2088	0.2699	0.2736
	153	152	153	153	153
LU_3200					
Shrub & Brushland	HARD	CA	PH	MG	TALK
	-0.26219	-0.23980	-0.22810	-0.21161	-0.21031
	0.0075	0.0147	0.0205	0.0319	0.0330
	103	103	103	103	103
	K	TN	CL	COND	NA
	-0.16848	-0.15140	-0.14399	-0.14337	-0.11295
	0.0889	0.1269	0.1468	0.1485	0.2560
	103	103	103	103	103

Spearman Rank Correlation, Lake Water Chemistry with Land Use

Correlation Analysis

Spearman Correlation Coefficients / Prob > |R| under Ho: Rho=0 / Number of Observations

LU_4100					
Upland Coniferous Forest (4100)	TURB	TSS	CHLA	FTSI	K
	-0.36209	-0.33373	-0.32437	-0.29609	-0.27632
	0.0061	0.0120	0.0147	0.0267	0.0393
	56	56	56	56	56
	ORTP	TP	NA	COND	SECCHI
	-0.20827	-0.20726	-0.19208	-0.16289	0.12665
	0.1235	0.1253	0.1561	0.2303	0.3963
	56	56	56	56	47
LU_4110					
Pine Flatwoods (4110)	COND	ORTP	NA	COLOR	NOX
	-0.18752	0.18248	-0.16755	0.16503	0.15433
	0.1174	0.1277	0.1625	0.1690	0.1988
	71	71	71	71	71
	PH	MG	CL	S04	K
	-0.15153	-0.14353	-0.13948	-0.13804	-0.13732
	0.2071	0.2324	0.2460	0.2545	0.2535
	71	71	71	70	71
LU_4120					
Longleaf Pine-Xeric Oak (4120)	K	CHLA	MG	SECCHI	NOX
	-0.44182	-0.36234	-0.28642	-0.25453	0.25132
	0.0062	0.0275	0.0857	0.1747	0.1335
	37	37	37	30	37
	CL	NA	FTSI	TP	CA
	-0.25079	-0.22638	-0.12980	0.12470	0.10922
	0.1343	0.1779	0.4439	0.4621	0.5199
	37	37	37	37	37
LU_4340					
Hardwood-Conifer Mixed (4340)	S04	K	NA	COLOR	CL
	-0.35402	-0.30396	-0.25538	0.24480	-0.22335
	0.0001	0.0001	0.0005	0.0008	0.0022
	185	185	185	185	185
	FE	COND	MG	ORTP	NOX
	0.22086	-0.21520	-0.20898	-0.12892	-0.12888
	0.0025	0.0033	0.0043	0.0803	0.0804
	185	185	185	185	185
LU_6210					
Cypress (6210)	TSS	CL	NA	CA	HARD
	0.22439	0.19993	0.19751	-0.18750	-0.18559
	0.0315	0.0560	0.0591	0.0735	0.0765
	92	92	92	92	92
	K	TURB	NOX	ORTP	FE
	0.17123	0.16742	0.14956	0.14672	-0.13971
	0.1027	0.1107	0.1547	0.1628	0.1841
	92	92	92	92	92

Spearman Rank Correlation, Lake Water Chemistry with Land Use

Correlation Analysis

Spearman Correlation Coefficients / Prob > |R| under Ho: Rho=0 / Number of Observations

LU_6410					
Freshwater Marshes (6410)					
	COLOR	SECCHI	FE	COND	S04
	0.26452	-0.14317	0.13813	-0.12200	-0.10368
	0.0001	0.0386	0.0355	0.0636	0.1161
	232	209	232	232	231
	NOX	NA	TKN	HARD	FTSI
	-0.07658	-0.05649	0.05609	-0.05170	0.05023
	0.2453	0.3918	0.3951	0.4332	0.4464
	232	232	232	232	232
LU_6430					
Wet Prairies (6430)					
	CA	CL	HARD	COND	TALK
	-0.37256	-0.35551	-0.34114	-0.33576	-0.32202
	0.0018	0.0029	0.0044	0.0051	0.0074
	68	68	68	68	68
	NA	K	PH	MG	S04
	-0.27317	-0.26283	-0.23739	-0.20230	-0.12776
	0.0242	0.0304	0.0513	0.0980	0.2991
	68	68	68	68	68
LU_8100					
Transportation (8100)					
	TKN	ORTP	TN	TP	SECCHI
	-0.25905	-0.18567	-0.17216	-0.16032	0.12691
	0.0096	0.0658	0.0884	0.1129	0.2280
	99	99	99	99	92
	CL	NA	FE	TURB	COLOR
	-0.12537	-0.12395	-0.12250	-0.11998	-0.11733
	0.2163	0.2216	0.2271	0.2368	0.2474
	99	99	99	99	99

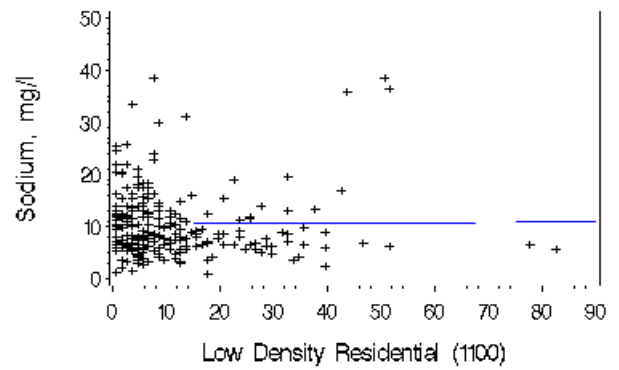
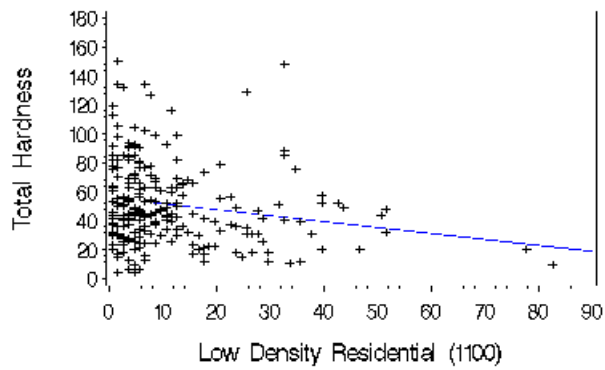
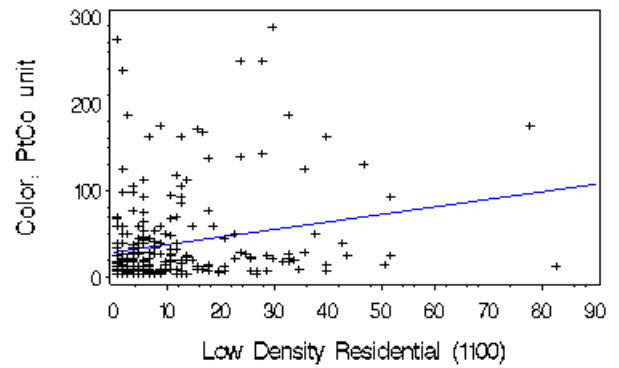
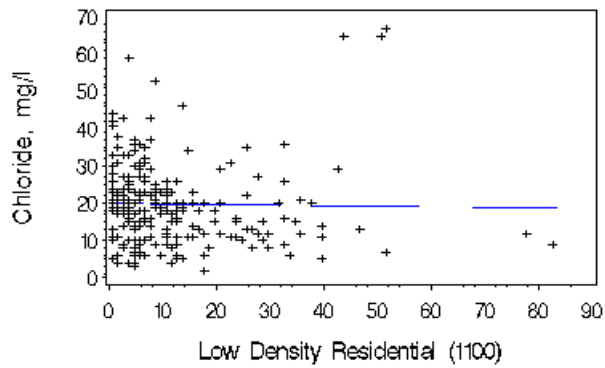
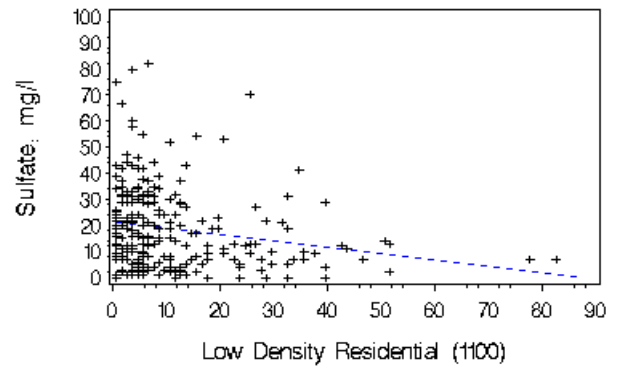
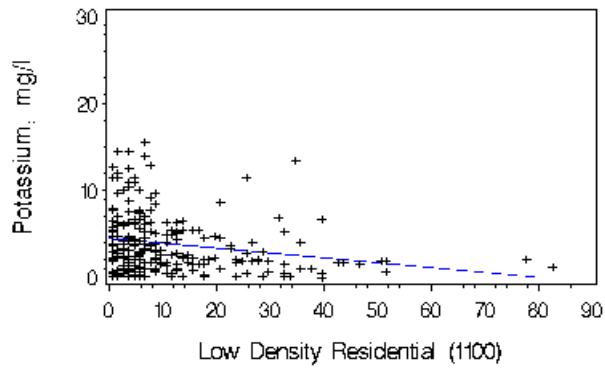
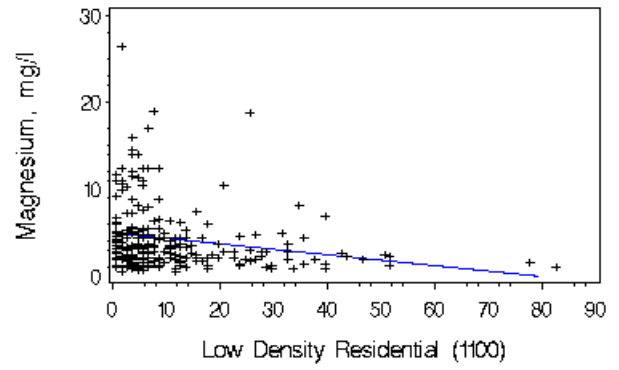
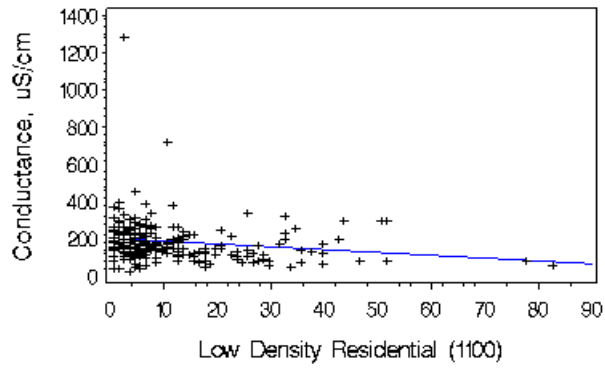

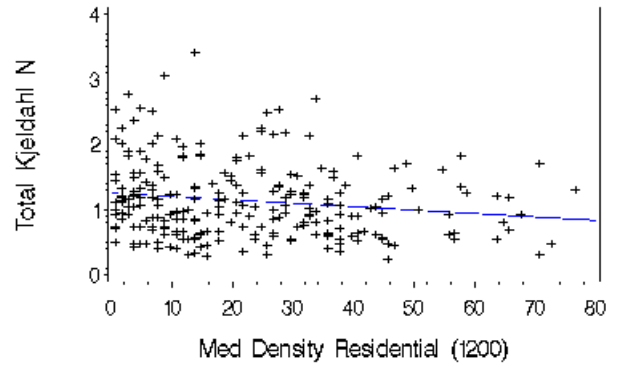
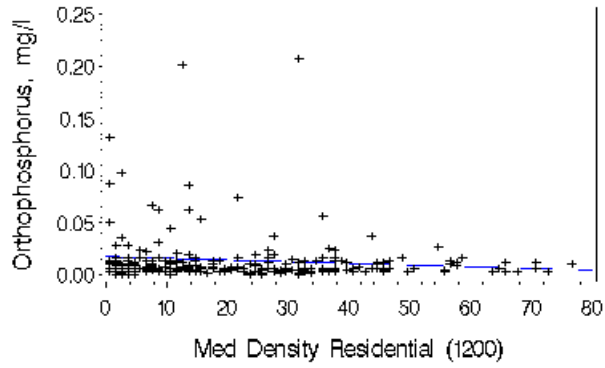
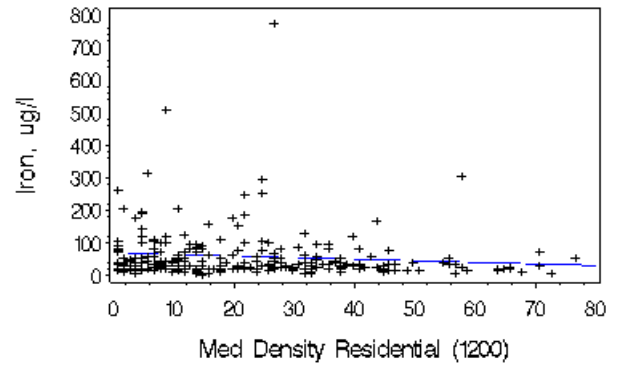
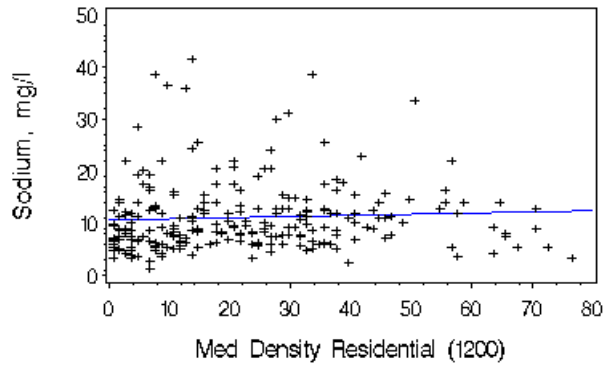
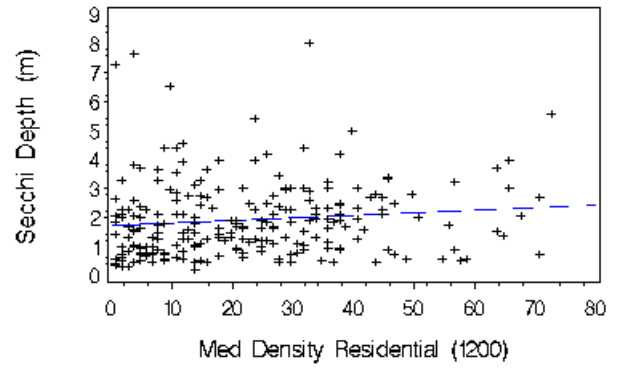
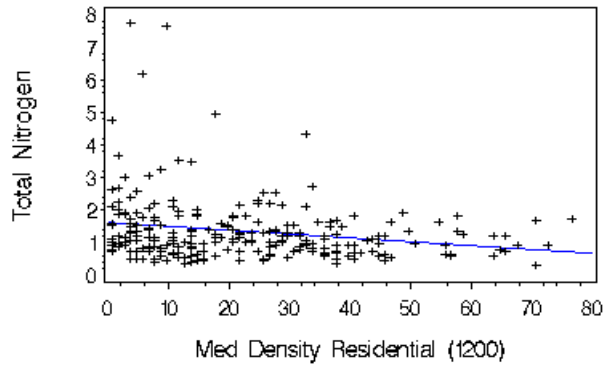
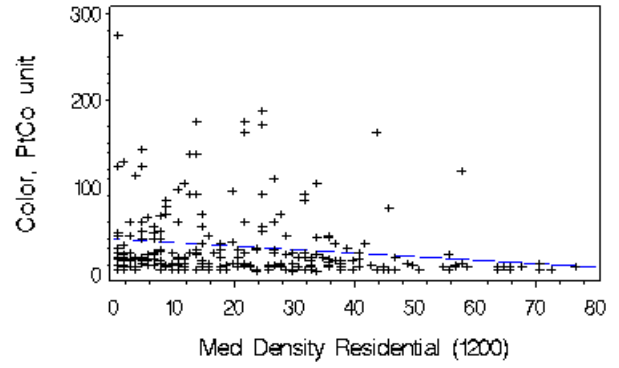
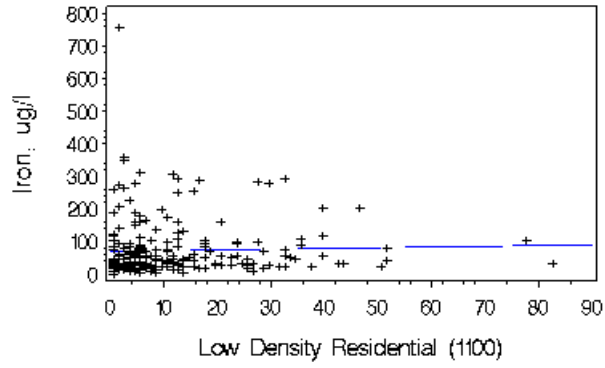

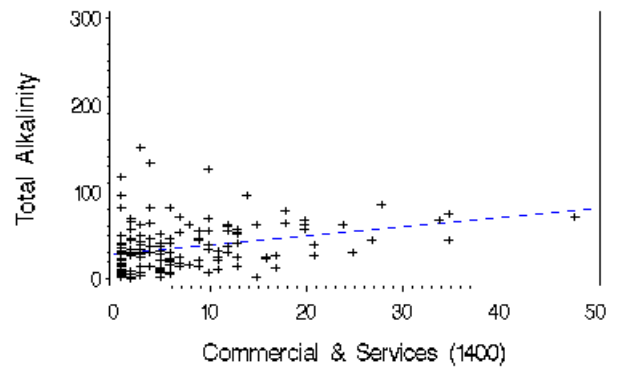
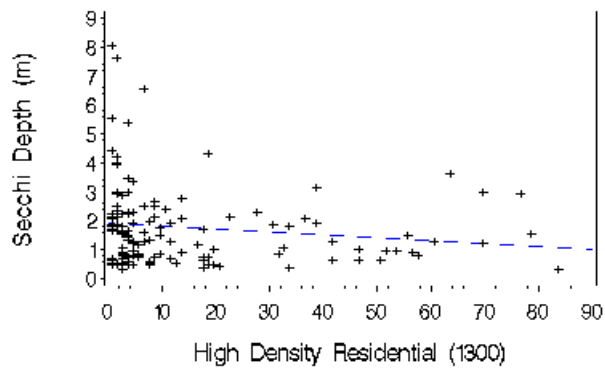
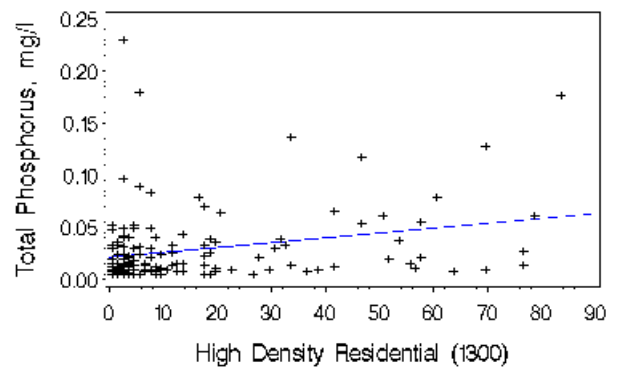
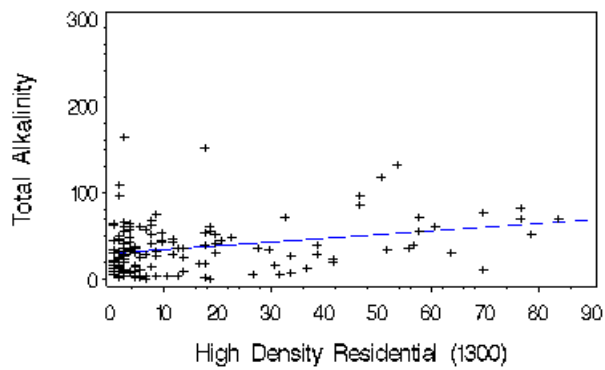
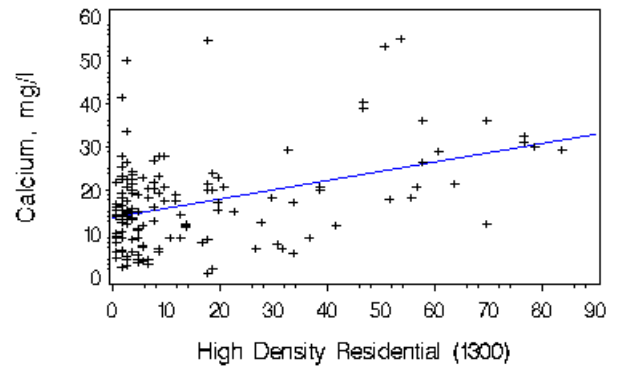
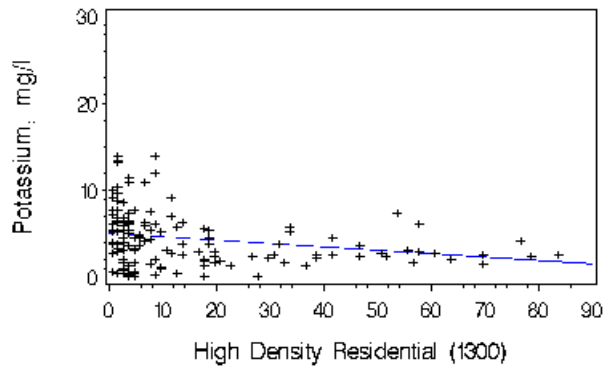
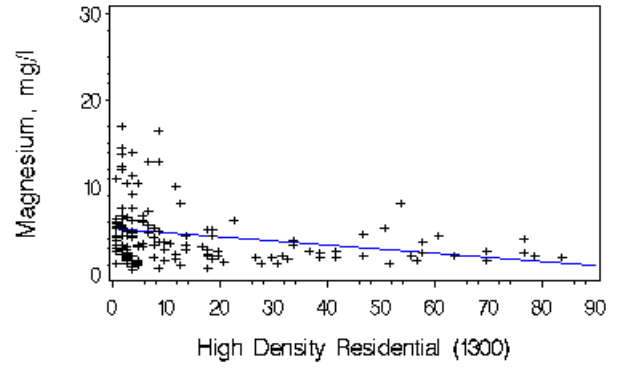
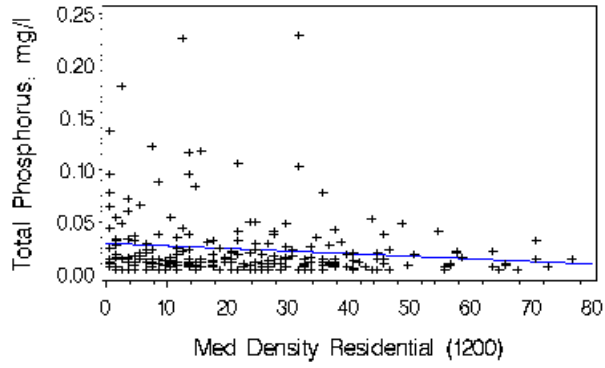

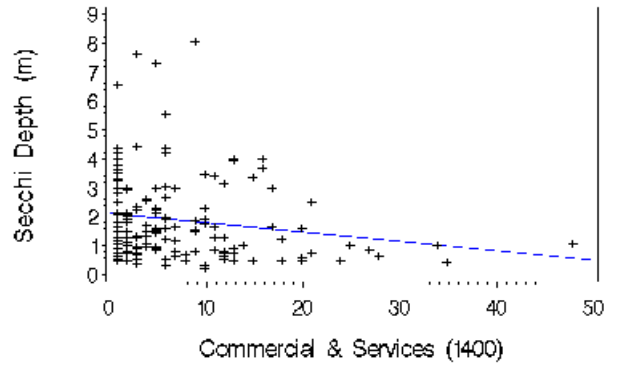
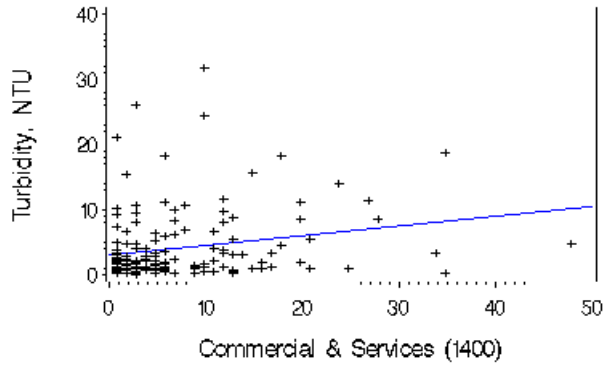
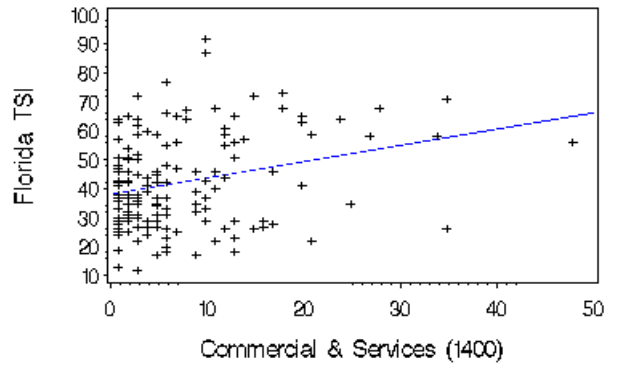
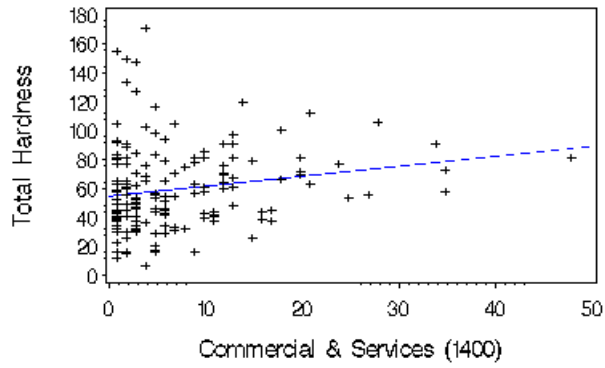
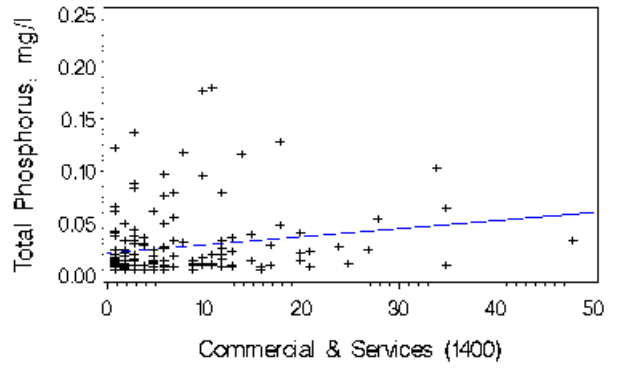
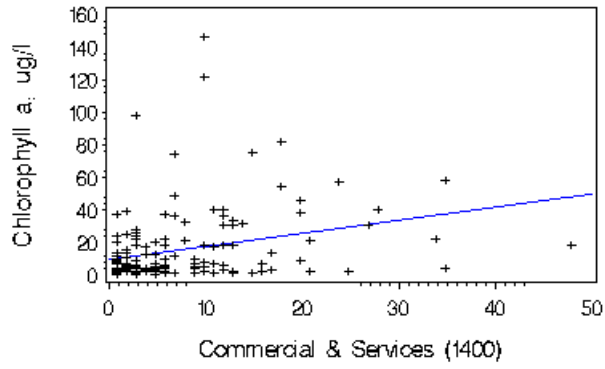
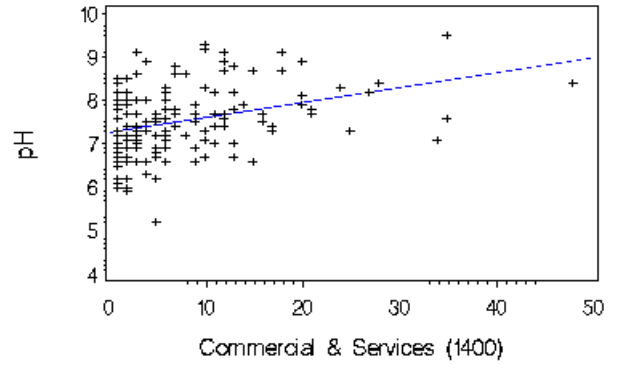
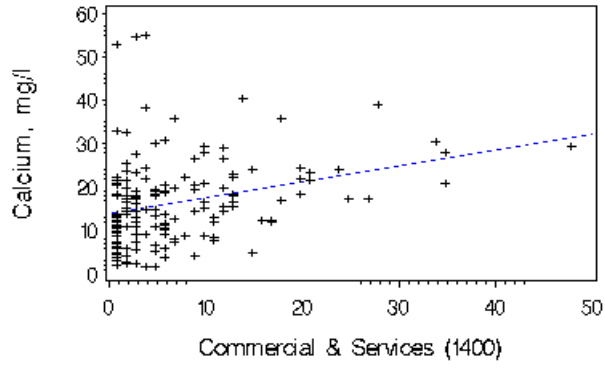

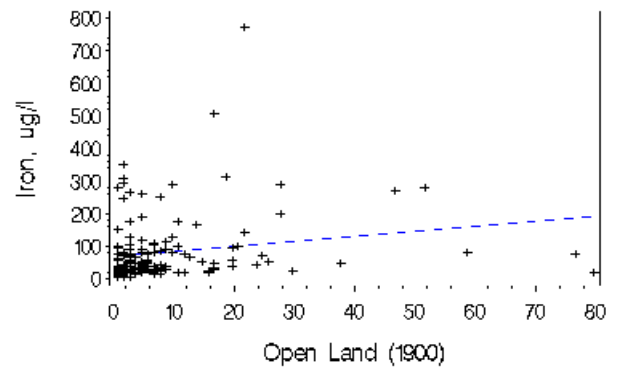
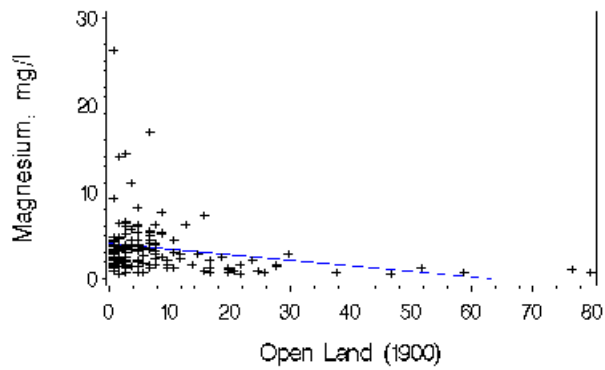
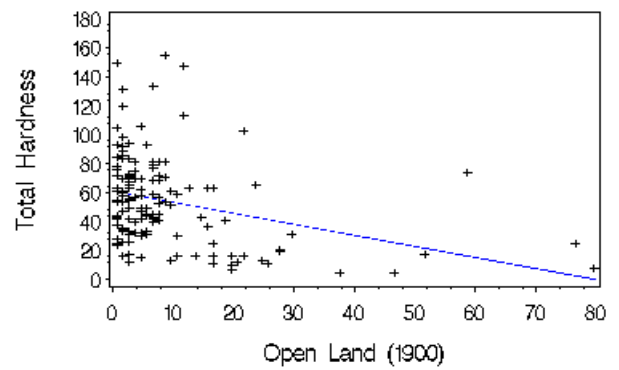
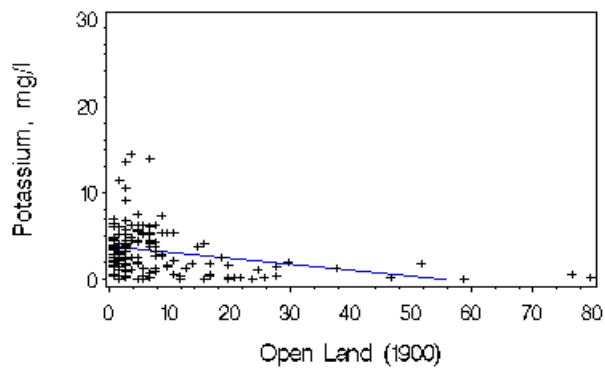
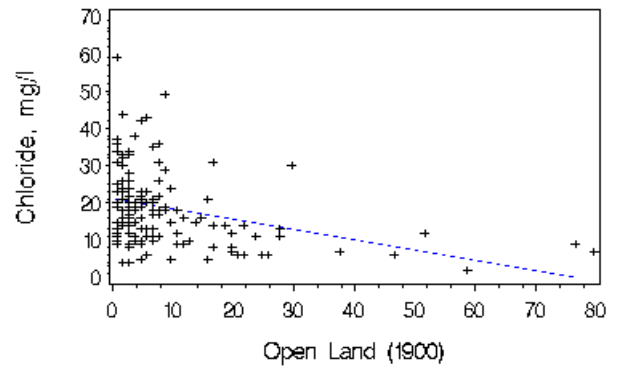
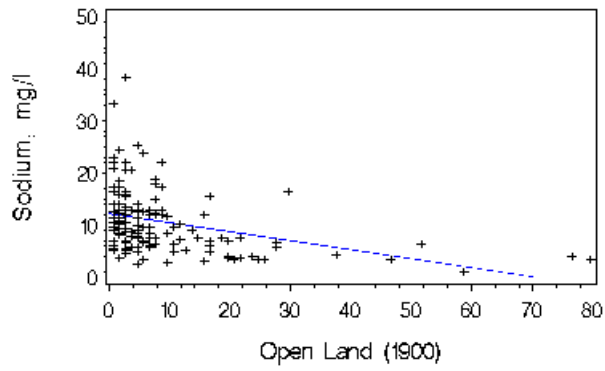
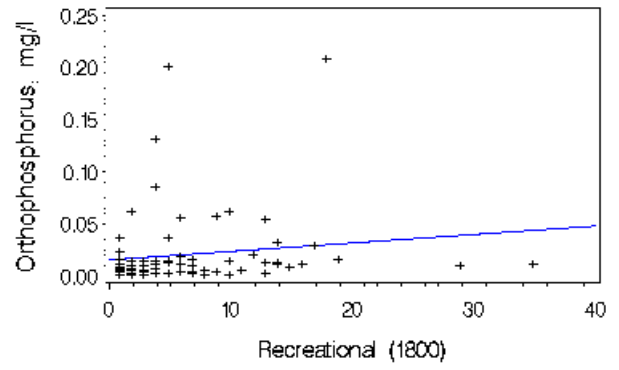
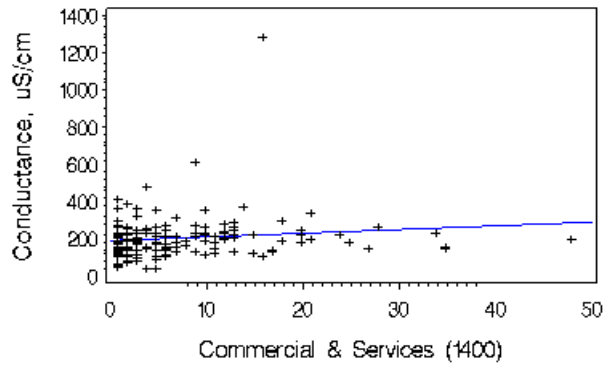

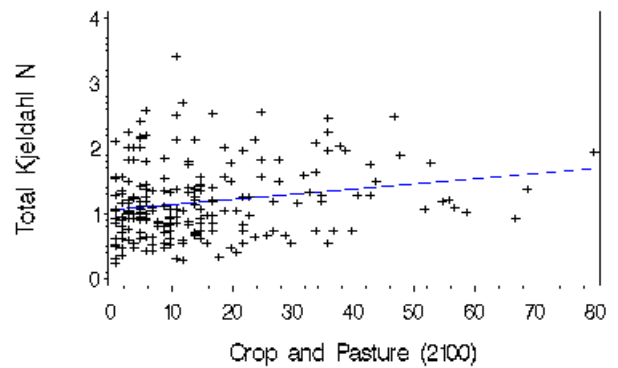
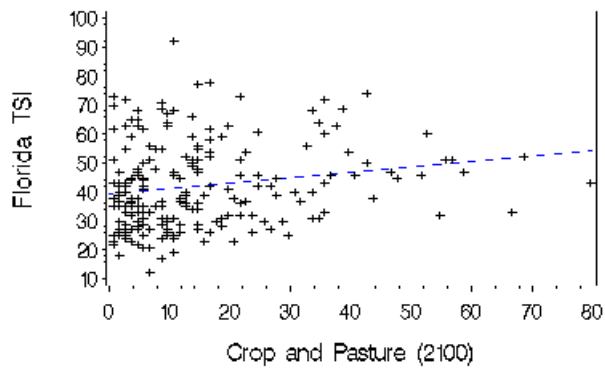
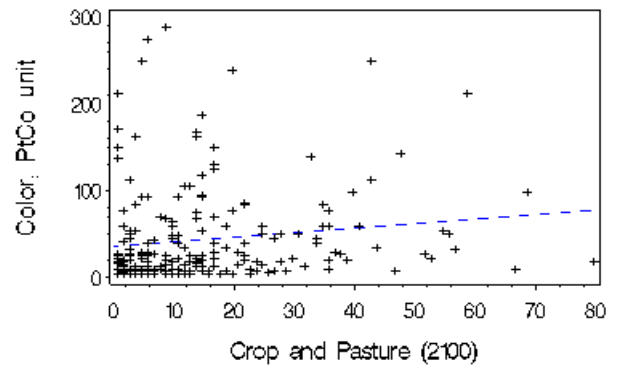
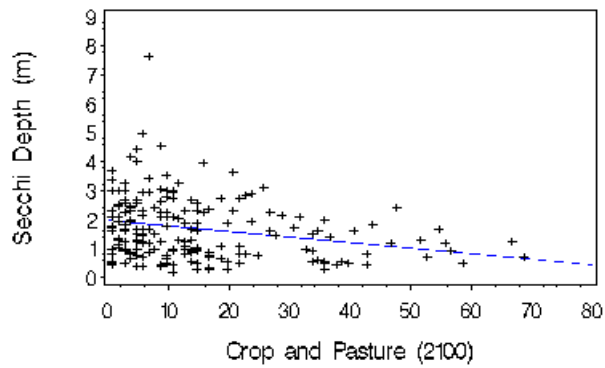
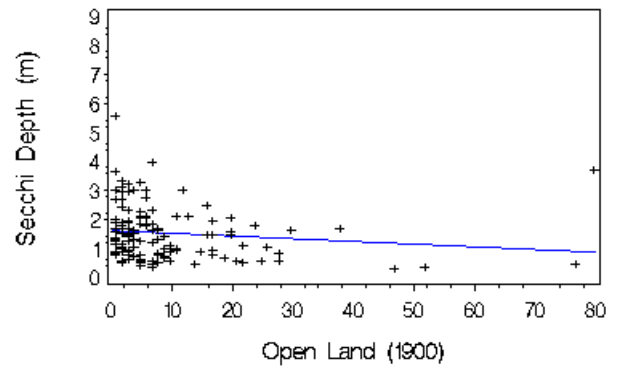
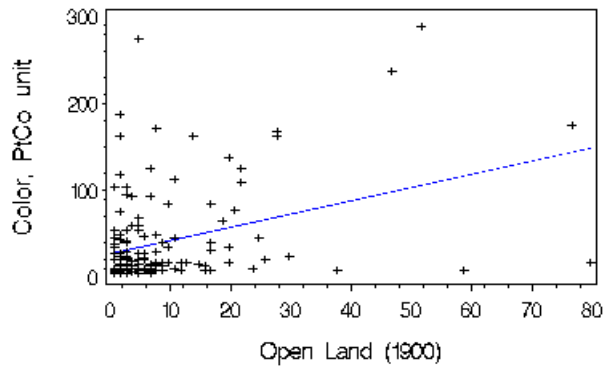
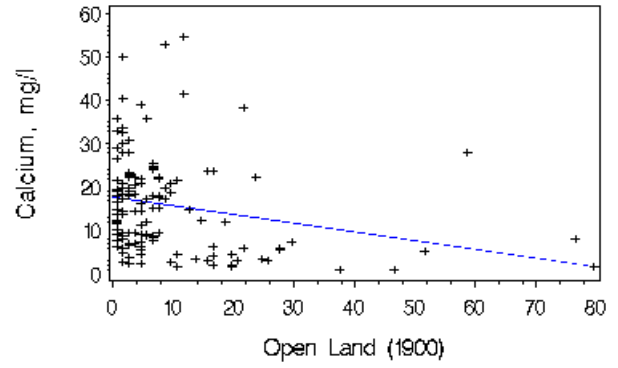
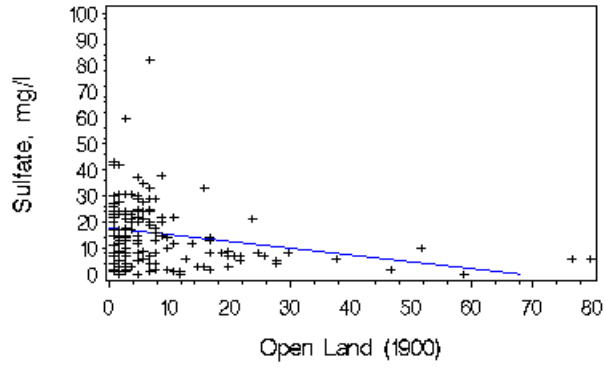

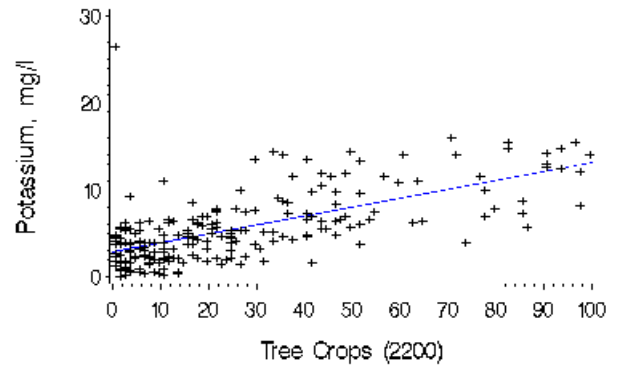
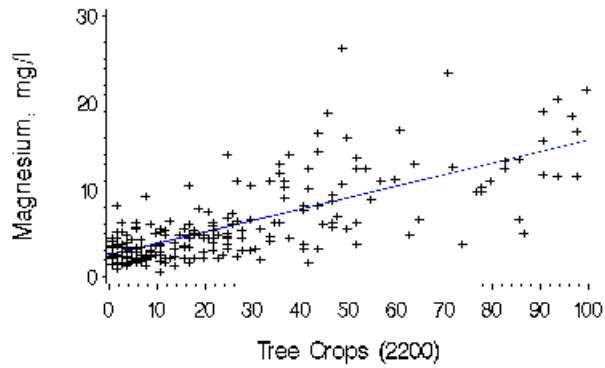
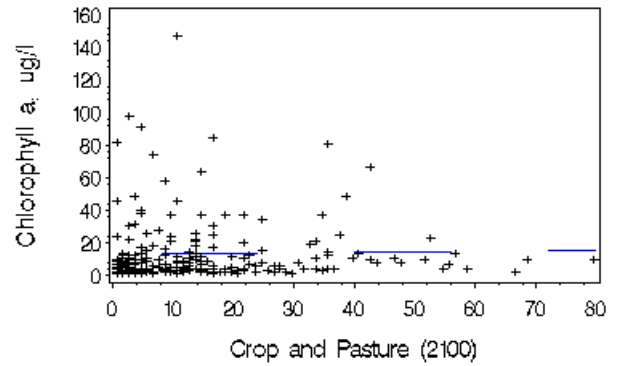
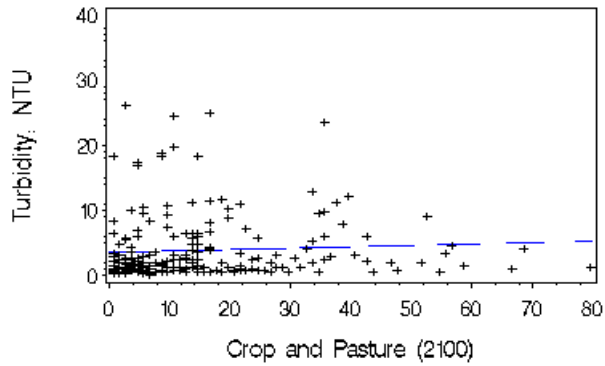
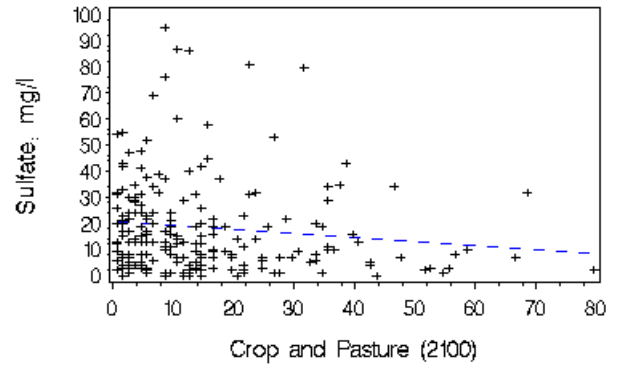
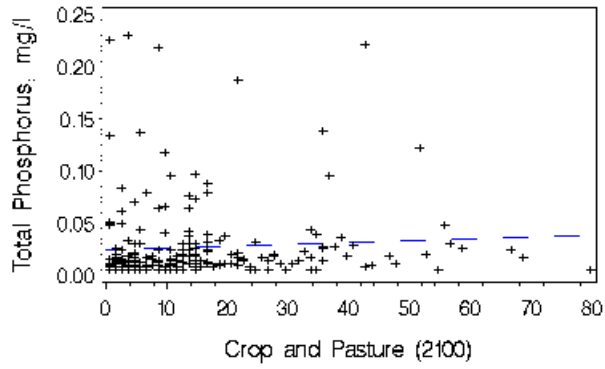
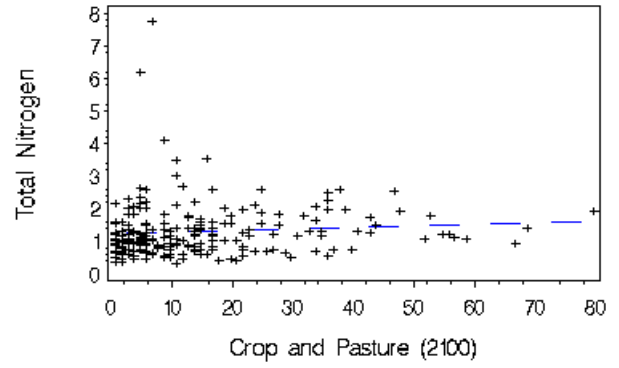
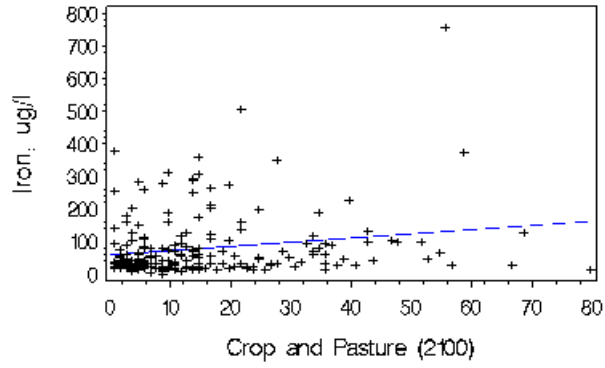

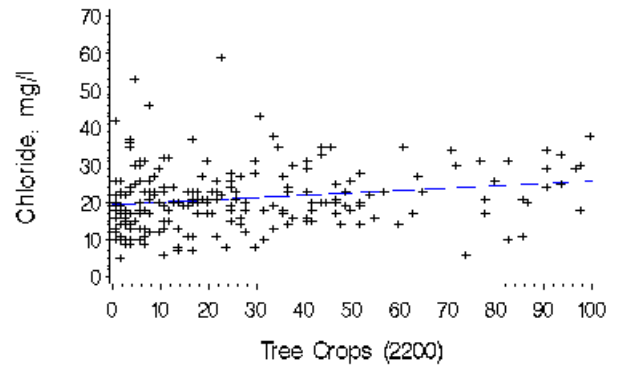
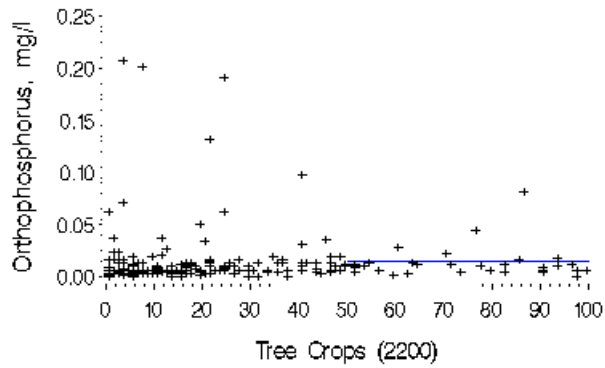
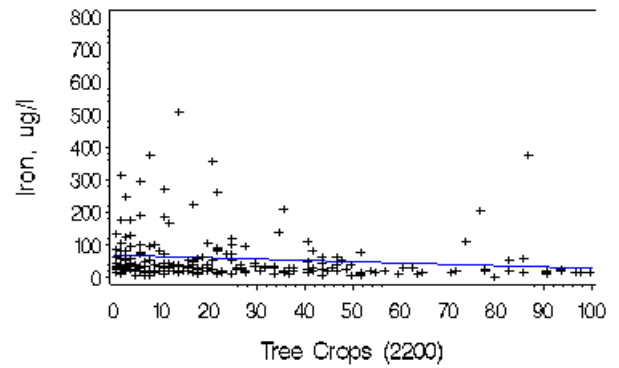
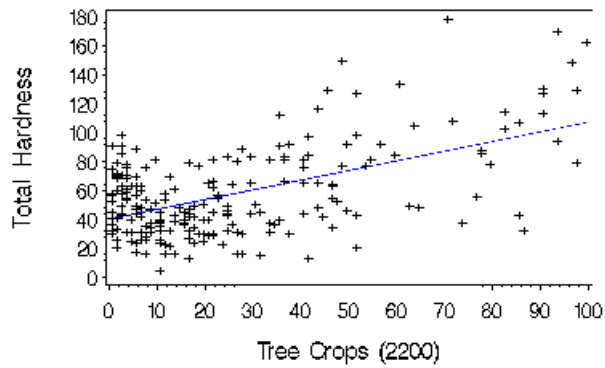
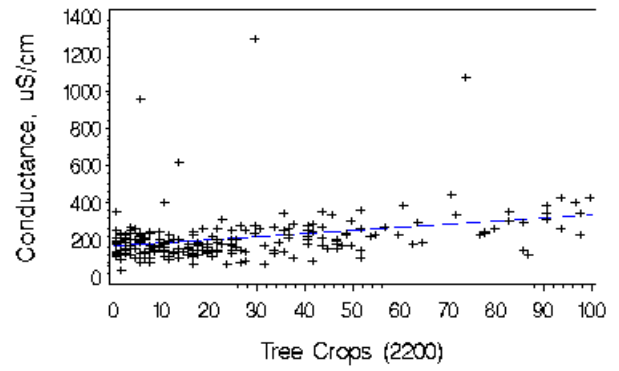
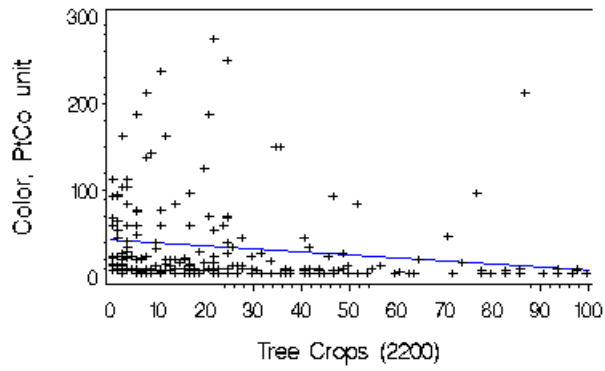
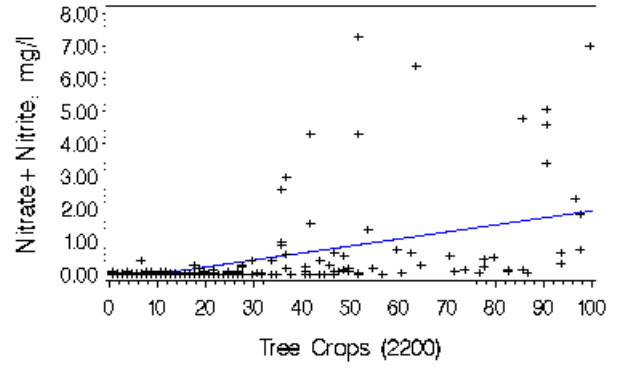
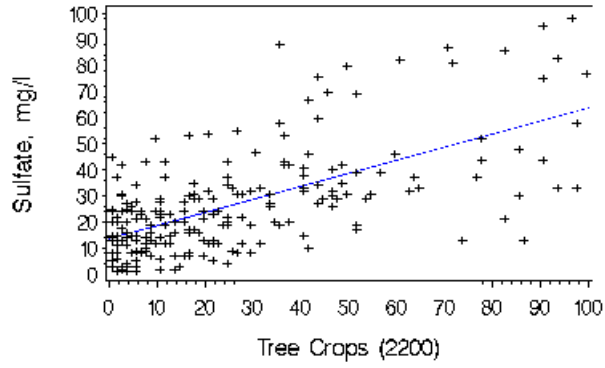

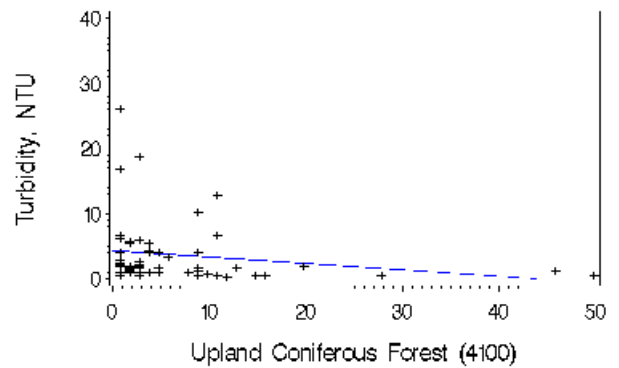
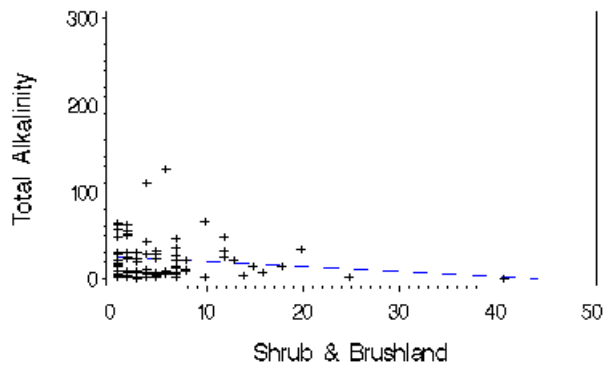
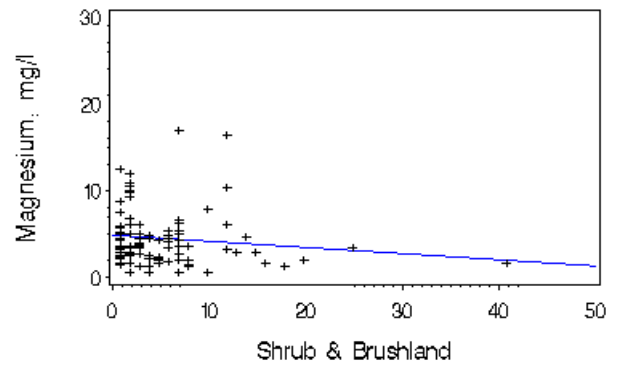
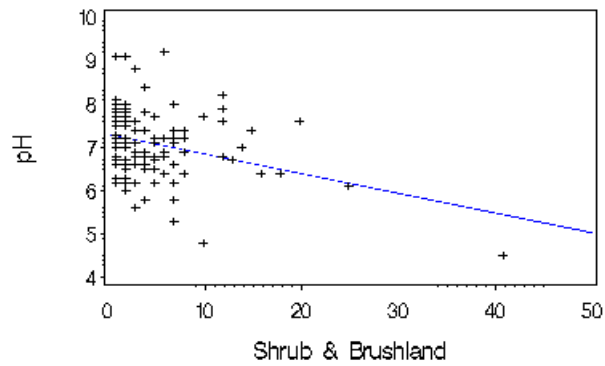
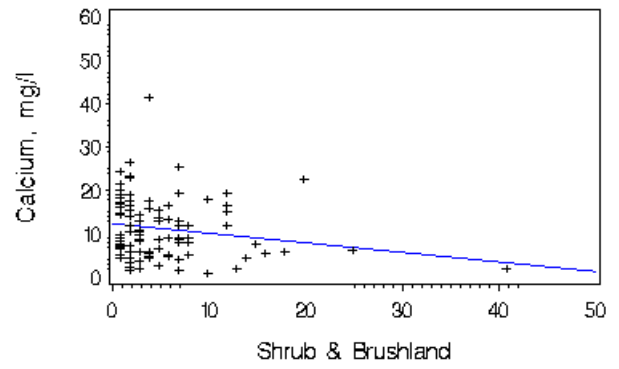
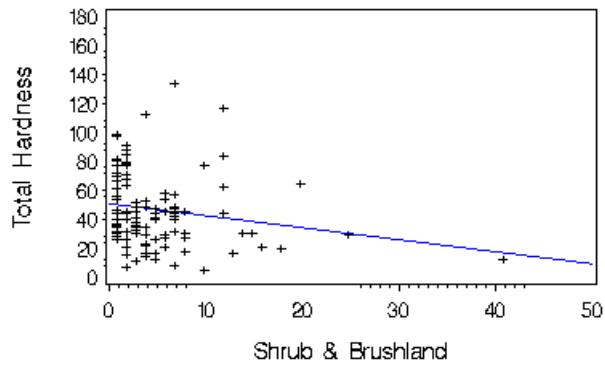
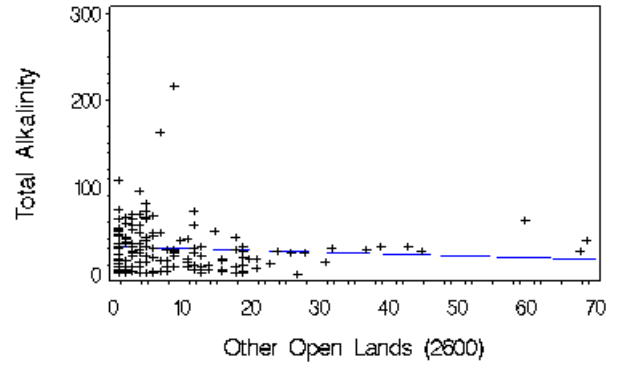
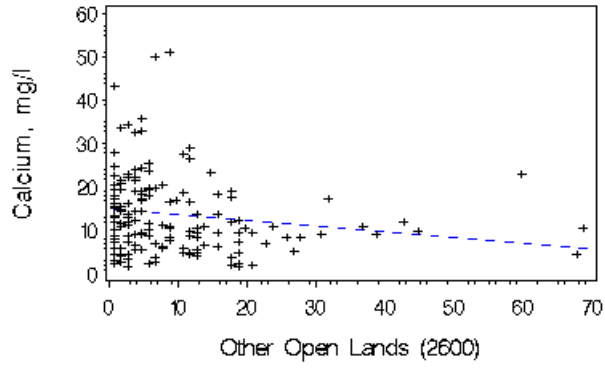

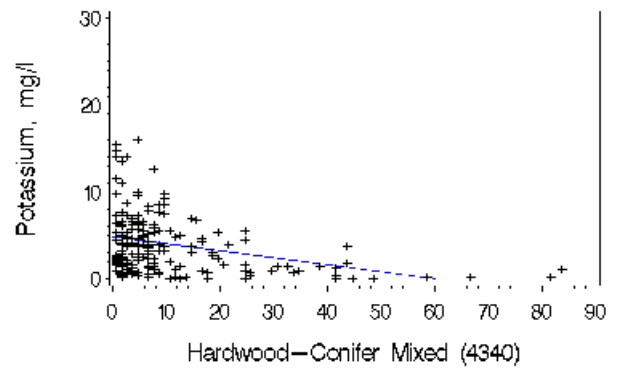
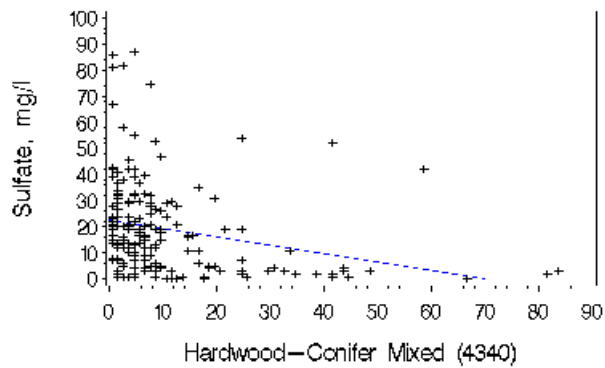
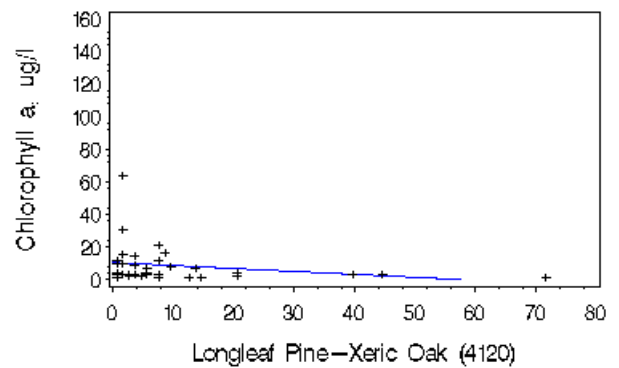
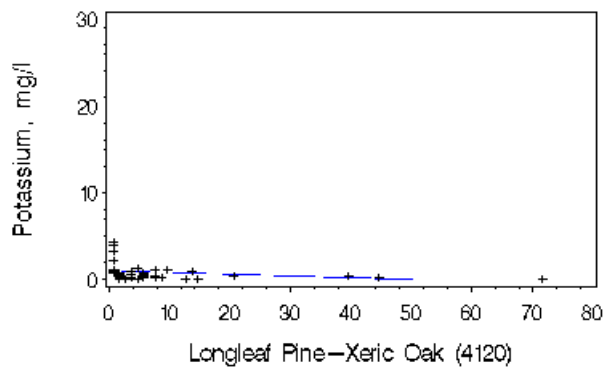
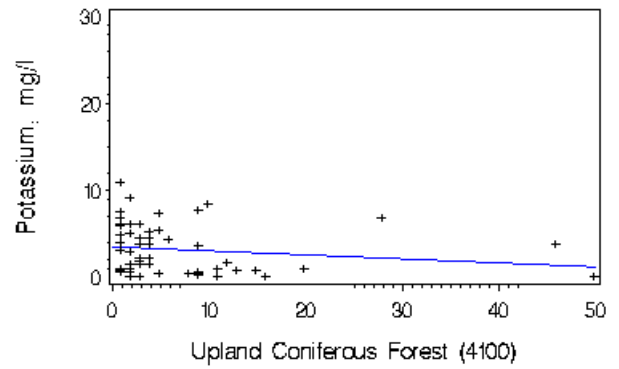
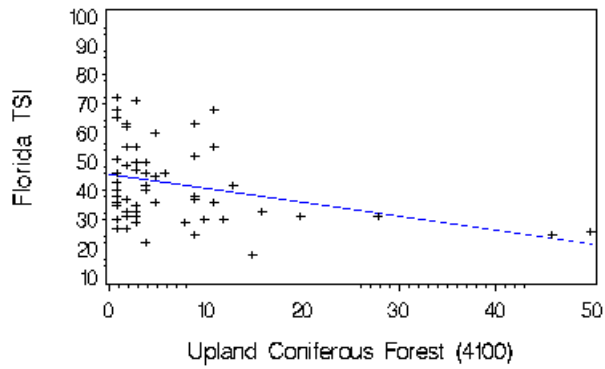
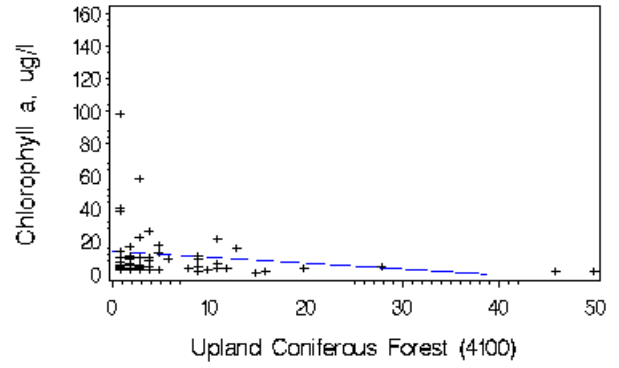
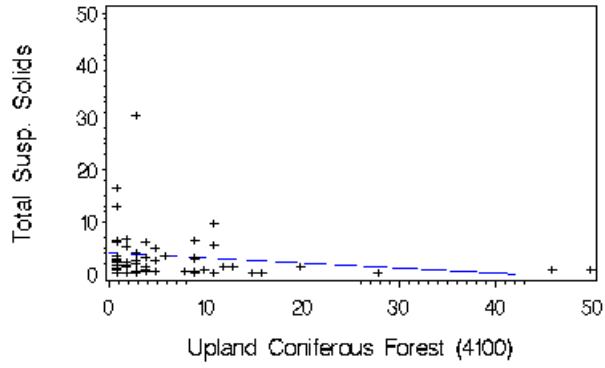

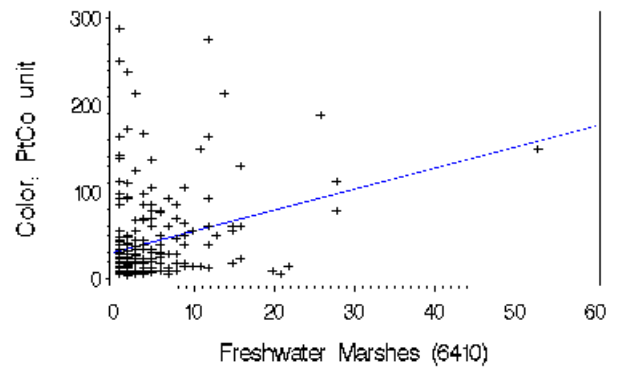
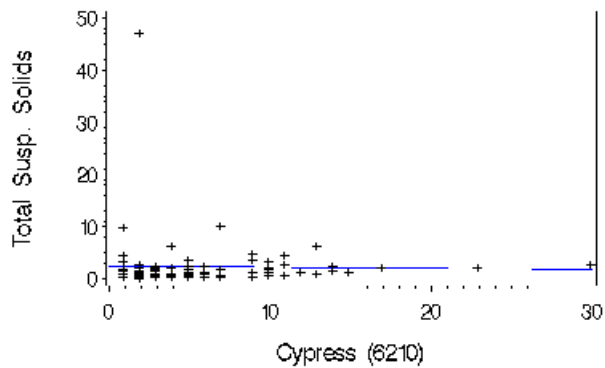
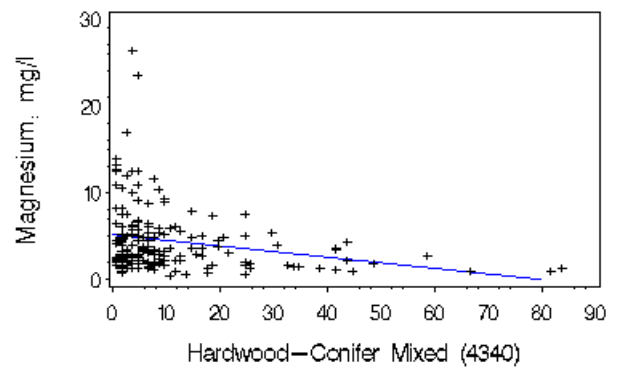
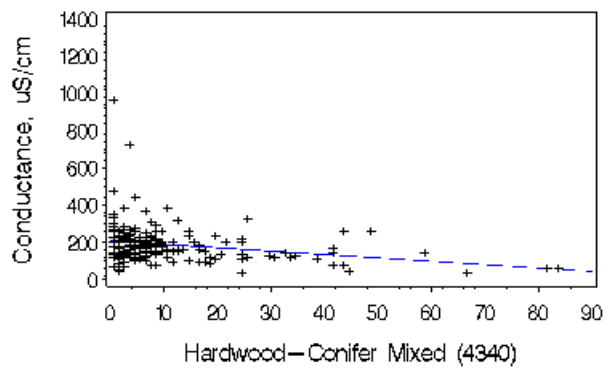
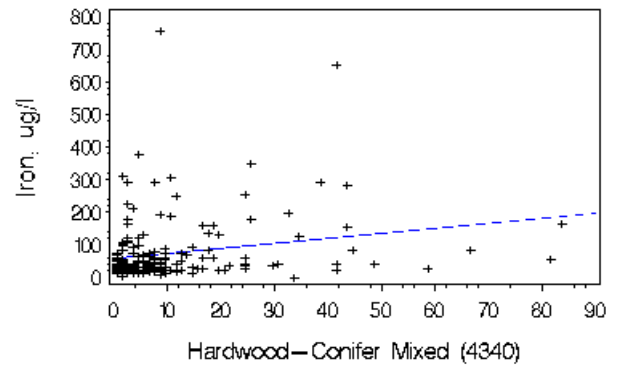
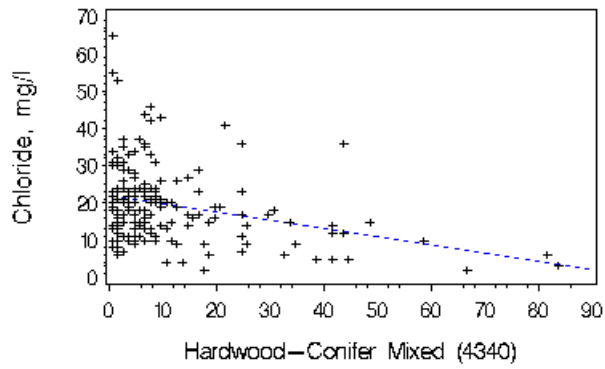
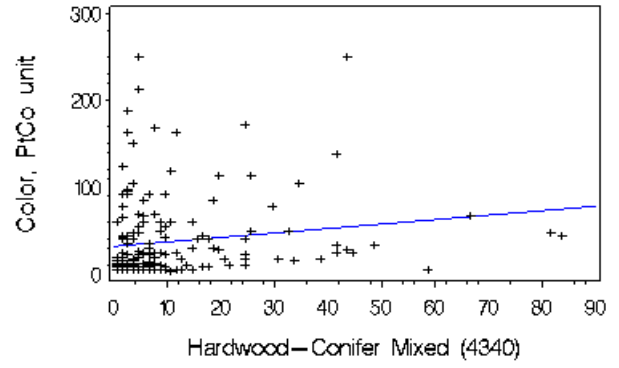
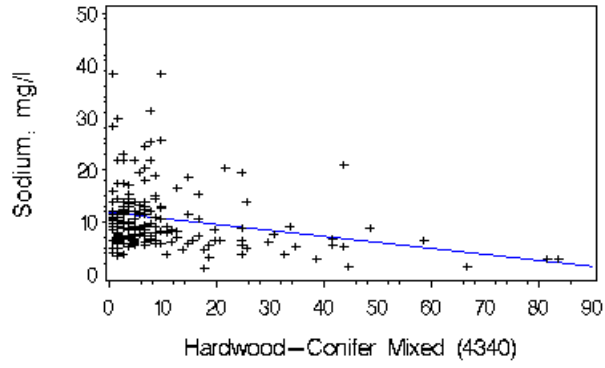

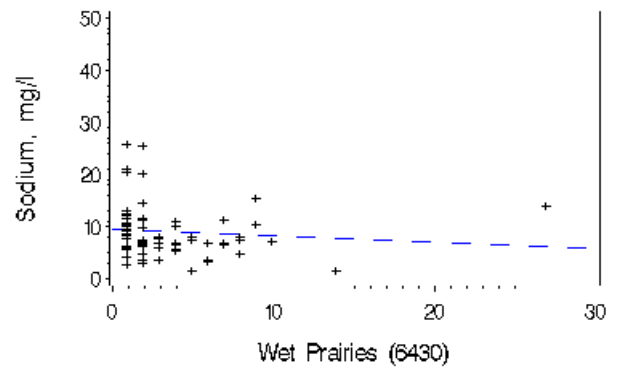
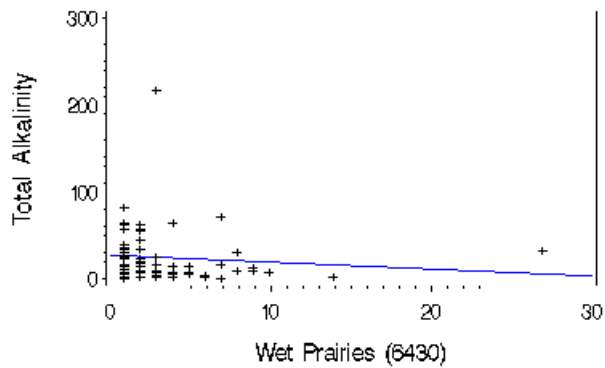
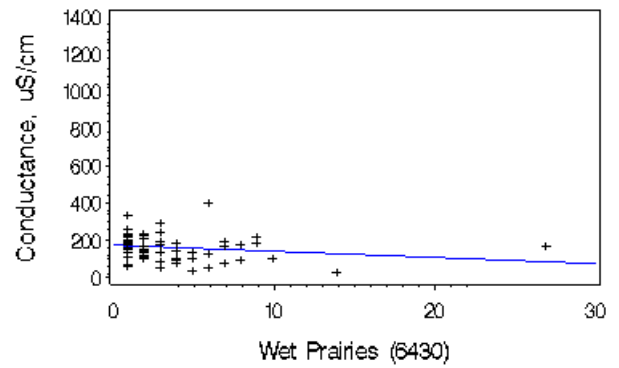
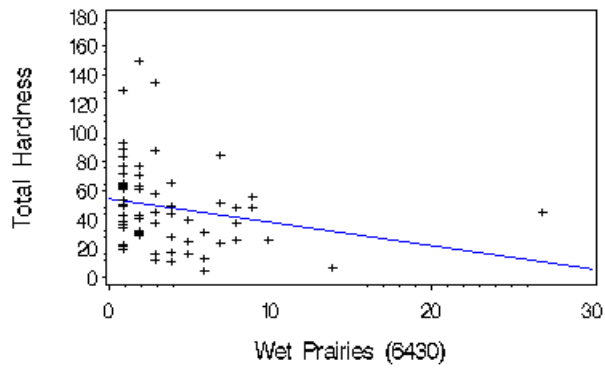
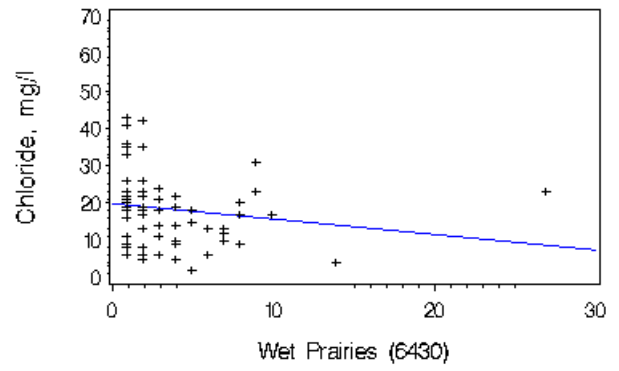
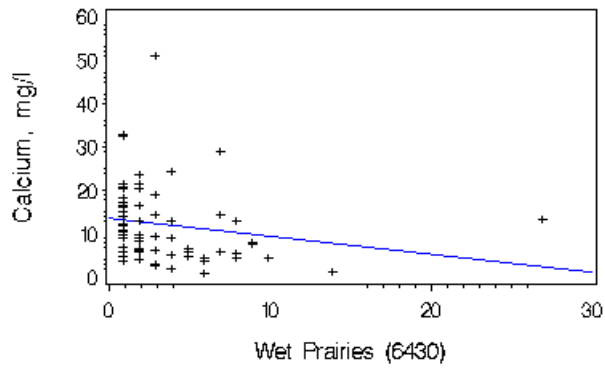
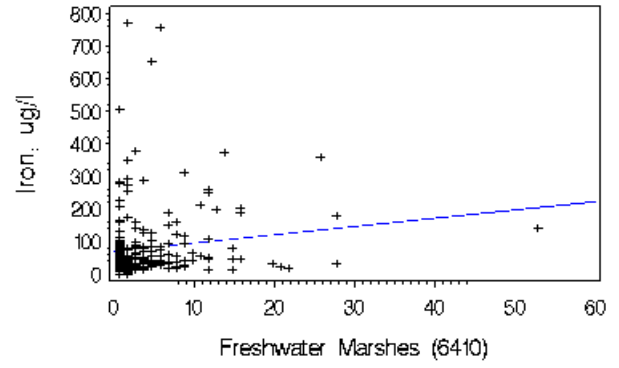
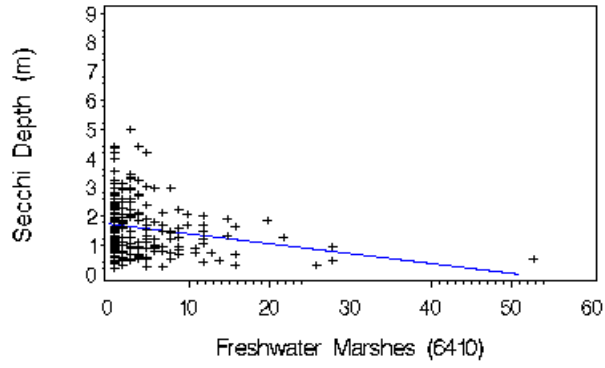

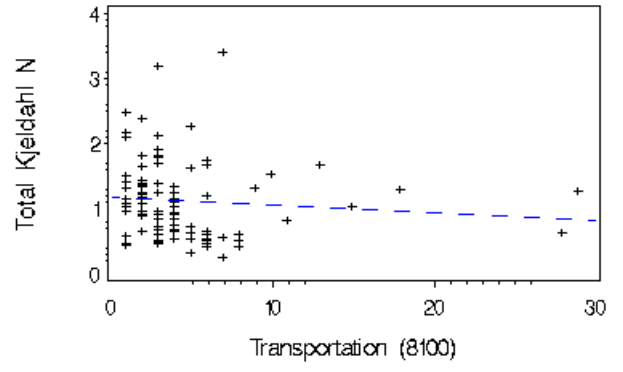
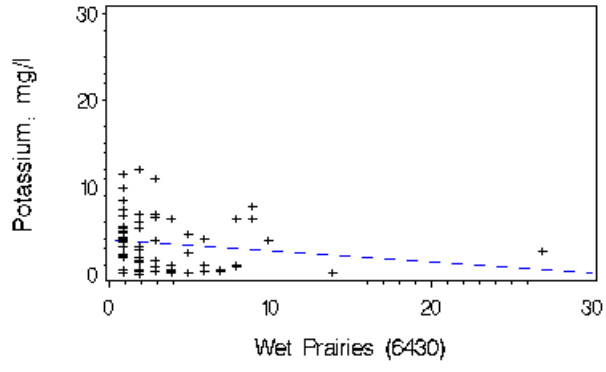

APPENDIX E

Data summary sheets for each lake sampled for the Southwest Florida Water Management District Lakes
Ambient Monitoring Program

a. Interpretation of Water Chemistry Measures

b. Interpretation of Data Summary Sheets

c. Interpretation of Water Chemistry and Lake Surface Elevation Plots

d. Data Summary Sheets

Interpretation of Water Chemistry Measures

The concentration of hydrogen ion in water is expressed as pH. A pH between 1 and 7 is acidic, pH 7 is neutral, and between 7 and 14 the pH is alkaline. pH is important because it affects the rate at which many chemical and biological processes occur. Natural waters in Florida generally range between pH 5 and pH 9. Biological communities are adapted to the acidic or alkaline conditions in which they are found, and these communities are threatened only when the conditions to which they are adapted are altered.

Alkalinity is a measurement of substances in the water, most frequently bicarbonates in Florida lakes, that tend to elevate pH and buffer the water against increases in acidity. Alkalinity can be an important factor affecting the biology of the lake, by stabilizing pH in ranges supportive of a wide range of aquatic life.

Specific conductance is a measure of the ability of water to conduct an electric current. Conductance is directly related to concentrations of ions in the water, especially chloride, sulfate, sodium, calcium and other inorganic ions.

The ions (chloride, sulfate, sodium, potassium, calcium, and magnesium) are dissolved from rocks and soils in contact with the lake or inflowing waters. Some ions may also be carried in the air and be deposited by rainfall as, for example, in coastal areas where sodium and chloride and other salts in salt sprays can be carried inland and affect the chemical composition of lakes. Calcium and magnesium are the cause of most of the hardness measured in waters.

Color in natural waters is due to the decomposition of organic matter, usually in swamps draining to the lake. Decomposition releases humic substances which usually stain the water yellow to brown. Water samples are filtered before the color is determined and only color due to dissolved substances is reflected in the measurement.

Turbidity is a measure of the scattering of light in water by particles suspended in the water. Particles that affect turbidity include algae, zooplankton, aquatic and terrestrial plant materials, resuspended sediment, and numerous inorganic particulates. Total suspended solids (TSS) measures much the same thing, and is typically correlated with turbidity.

Phosphorus and nitrogen are the primary nutrients which regulate the growth of algae and aquatic plants in lakes. In most lakes, either nitrogen or phosphorus may at times limit the growth of algae, and in abundance they can cause accelerated eutrophication of the lake. Many Florida lakes have naturally high concentrations of these nutrients, but phosphate mining, agriculture, stormwater runoff, and other human activities within the watershed can increase the concentrations of nitrogen and phosphorus. When the concentrations consistently exceed the natural levels, undesirable changes in aquatic communities may occur.

Total nitrogen is composed of various nitrogen forms: ammonia, nitrite, nitrate, and organic nitrogen. Nitrite is rarely present in measurable concentrations because it is not stable in the presence of oxygen, but is rapidly converted by microorganisms to nitrate. Ammonia and nitrate are inorganic forms that are most readily taken up by the algae and aquatic plants, and so are often in low concentrations in most natural waters. Nitrate is often analyzed together with nitrite, and reported as nitrate+nitrite. Organic nitrogen is nitrogen bound in proteins, amino acids, and other nitrogen containing compounds and usually represents the greatest proportion of total nitrogen. Decomposition of organic nitrogen into ammonia is necessary for it to be available to algae

and aquatic plants. Total Kjeldahl nitrogen, or TKN, is the sum of ammonia and organic nitrogen.

Total Phosphorus includes both organic and inorganic forms of phosphorus. Many forms of phosphorus are unavailable for use by aquatic plants and organisms because they are biologically or chemically bound. Total phosphorus represents the pool of potentially available phosphorus for aquatic life. Orthophosphate is the inorganic component of total phosphorus, and in its dissolved state is the most available form of phosphorus for the growth of algae and aquatic plants. In waters in which phosphorus is the limiting nutrient, concentrations of orthophosphate are typically very low.

Chlorophyll *a* is the pigment that gives most plants, including aquatic algae, their characteristic green color. As a measure of water chemistry it provides an index of the abundance of algae in waters -- the greater the concentration of chlorophyll *a*, the greater the abundance of algae. Algae are primary producers in the aquatic food web, and thus are very important for characterizing the productivity of lakes, and the ability of the lake to support an abundance of aquatic organisms.

Transparency is measured with a Secchi disk, an 8-inch black and white disk that is lowered into the water until it just disappears. The depth at which it disappears is the Secchi depth. It is affected by the presence of materials in the water column which absorb and scatter light, including color, algae, zooplankton, and other dissolved and suspended materials. Water chemistry measures which are related to water transparency include total suspended solids, chlorophyll *a*, turbidity and color. The greater the transparency, the 'clearer' the water.

The Florida Trophic State Index (FTSI) was devised to integrate different but related measures of lake productivity or potential productivity, into a single number that ranges from 0 to 100. The measures included in the calculation are transparency (Secchi depth), chlorophyll *a*, total nitrogen and total phosphorus. The Florida Department of Environmental Protection suggests that a FTSI from 0 to 59 is good, 60 to 69 is fair, and 70 to 100 is poor. There are factors which can cause an over- or underestimation of trophic state, such as lakes that are highly colored, and lakes with large volumes of aquatic plants. However, the FTSI is generally useful for comparing lakes, and for tracking changes in water quality over time.

Interpretation of Lake Data Sheets

USGS Quadrangle: US Geological Survey 7.5 minute quadrangle that includes all or the greatest portion the lake.

Major Land Use/Land Cover (1990) within 500 meters of the lakeshore: A GIS (graphical information system) was used to construct a 500 meter (1640.4 feet) -buffer around each lake. Land use was determined from 1990 land use coverages for the area within each buffer; expressed as percent of the total buffer area.

Section/Township/Range: from Gant (1997)

Approx. Lake Center, Lat/Long: visually estimated from USGS quadrangle

Surface Area: lake surface area in acres

Approx. Lake Elevation: if not printed on USGS quadrangle, then estimated from nearest 5-foot contour line on the quadrangle.

average depth: estimated from existing maps using a sampling grid, or from available documents.

observed maximum depth: estimated from existing maps, or from available documents.

Lake Type: from Florida Lake Gazetteer, or estimated from USGS quadrangle. Lake type 1 is an inflow lake, *i.e.*, a stream or canal flows into the lake but not out of the lake; type 2 is an outflow lake; type 3 has a point of flow both into and out of the lake; and type 4 is isolated, receiving all of its inflow from precipitation and groundwater, with loss to groundwater and evaporation.

Major Basin: USGS major hydrologic basin

Minor Basin: USGS secondary hydrologic basin

Lake Region: Florida Lake Region, from Griffith et al. (1997)

Public Access: “Yes” only if lake has a known point of public access.

Total Number of Samples Collected: Number of samples collected from the time the monitoring program was first initiated. Sampling has subsequently continued and other samples have likely been collected.

Most Recent Sample Collected: Most recently collected sample for this report, as above, other samples have likely been collected since the date shown.

Parameter: name of water chemistry analyte

Units: Units of reported value

Detection Limit: The analytical method used by the laboratory is able to detect the presence of the analyte at and above this value.

Average Value: the average concentration of the analyte for all samples collected. For this report, with a few exception, two samples were collected for each lake, and the average is of the two samples.

District Percentile: Percentile ranking of the subject lake among all 323 lakes sampled for the lakes monitoring program.

Florida Percentile: Percentile ranking of the subject lake among all Florida lakes, as reported by Friedemann and Hand (1989).

Lake Description: Brief description of water chemistry in the lake. Water quality was rated as good, fair or poor based primarily upon the Florida Trophic State Index (FTSI). The Florida Department of Environmental Protection suggests that a FTSI of 0 to 59 is good, 60 to 69 is fair, and greater than 69 is poor (Friedemann and Hand 1989). However, FTSI may over- or under-estimate trophic state, depending on water color, the abundance of aquatic plants in the lake, and other factors. Trophic status was generally estimated using the criteria of Forsberg and Ryding (1980), however, to some extent the evaluation of trophic status is subjective, and arguable. Also noted are unusually high or low concentrations of water chemistry constituents, based upon their percentile rankings. Also noted is the presence of non-native plants, including *Hydrilla*, waterhyacinth, and *Melaleuca*; , and the native specie cattails if their coverage was visually estimated to be greater than 30 percent of the shoreline length. Any trends in water chemistry or lake surface elevation are also noted, for plots

displayed on the page that follows each lake summary page. In most cases, no trends could be easily visualized in the data, due to the low number of samples, and the infrequency of sampling in most lakes.

Interpretation of Water Chemistry and Lake Surface Elevation Plots

Water chemistry data plotted are from District samples, and from the US Environmental Protection Agency STORET water chemistry database. For many of the lakes, historical data for water chemistry were very few or entirely absent. This situation is rapidly changing, due to increased monitoring by local governments and volunteer monitoring efforts such as Florida Lakewatch. Water elevation data are from data collected by the US Geological Survey and by the Southwest Florida Water Management District. The dashed lines on the plots of water surface elevation represent the median of the average monthly surface elevations for the period of record and are presented as a reference for the mean monthly data points plotted. The plot of major ions, presented for nearly all of the lakes, is a graphical representation of the proportion of major ions in the lake water (from Hutchinson 1975). The area of the each shaded segment is proportional to the percent equivalent concentration of the major anions and cations.

Data Summary Sheets

**The data summary sheets are organized alphabetically
by name within county, and follow this page.**

Index to Lake Data Summary Sheets (click on the page link)

CITRUS COUNTY LAKES

[Bellamy Lake](#)
[Cato Lake](#)
[Connell Lake](#)
[Cooter Lake](#)
[Croft Lake](#)
[Davis Lake](#)
[Dodd Lake](#)
[Floral City Lake](#)
[Fort Cooper Lake](#)
[Hampton Lake](#)
[Henederson Lake](#)
[Hernando Lake](#)
[Hog Pond \(Lake Nina\)](#)
[Holden Lake](#)
[Little Lake \(Consuella\)](#)
[Little Henderson Lake](#)
[Magnolia Lake](#)
[Rush Lake](#)
[Spivey Lake](#)
[Todd Lake](#)
[Tussock Lake](#)
[Van Ness Lake](#)

HERNANDO COUNTY LAKES

[Bonnett Pond](#)
[Bystre Lake](#)
[Double Cypress Pond](#)
[Lake Geneva](#)
[Highland Lake](#)
[Hunters Lake](#)
[Irvin Lake](#)
[Lake Lindsey](#)
[McClendon Lake](#)
[McKethan Lake](#)
[Rock Pond](#)
[Skinner Lake](#)
[Sparkman Lake](#)
[Spring Lake](#)
[Tank Lake](#)
[Tooke Lake](#)
[Unnamed Lake](#)

HIGHLANDS COUNTY LAKES

[Lake Adelaide](#)
[Lake Angelo](#)
[Lake Anoka](#)
[Lake Apthorpe](#)
[August Lake](#)
[Basket Lake](#)
[Blue Lake](#)
[Bonnet Lake](#)
[Brentwood Lake](#)
[Buck Lake](#)
[Lake Byrd](#)
[Lake Carrie](#)
[Lake Charlotte](#)
[Chilton Lake](#)
[Lake Clay](#)
[Lake Crews](#)
[Lake Damon](#)
[Deer Lake](#)
[Lake Denton](#)
[Dinner Lake](#)
[Duck Lake](#)
[Fox Lake](#)
[Lake Francis](#)
[Lake Glenada](#)
[Grassy Lake](#)
[Grassy Pond](#)
[Lake Harry](#)
[Lake Henry](#)
[Lake Hill](#)
[Hog Lake \(Granada\)](#)
[Huckleberry Lake](#)
[Lake Huntley](#)
[Lake Isis](#)
[Lake Jackson](#)
[Lake Josephine Center](#)
[Lake Josephine East](#)
[Lake Josephine West](#)
[Lake June in Winter](#)
[Lake Lachard](#)
[Lake Lelia](#)
[Lake Letta](#)

HIGHLANDS COUNTY LAKES

[Lake Lillian](#)
[Little Bonnet Lake](#)
[Little Jackson Lake](#)
[Little Red Water Lake \(North\)](#)
[Little Red Water Lake \(South\)](#)
[Lost Lake](#)
[Lake Lotela](#)
[Lake Lucas](#)
[Lake Lynn](#)
[Lake McCoy](#)
[Mirror Lake](#)
[Lake Nellie Center](#)
[Lake Nellie NW](#)
[Lake Nellie SE](#)
[Lake Olivia](#)
[Pansy Lake](#)
[Lake Pearl](#)
[Persimmon Lake](#)
[Lake Placid](#)
[Lake Pythias](#)
[Red Beach Lake](#)
[Red Water Lake](#)
[Lake Ruth](#)
[Saddlebags Lake](#)
[Lake Sebring](#)
[Silver Lake](#)
[Lake Simmons](#)
[Lake Sirena](#)
[Stormwater Pond](#)
[Lake Tulane](#)
[Unnamed "B" Lake](#)
[Unnamed "E" Lake](#)
[Lake Schumacher](#)
[Lake Verona](#)
[Lake Viola](#)
[Wolf Lake](#)

HILLSBOROUGH COUNTY LAKES

[Lake Alice](#)
[Lake Allen](#)
[Lake Barbara](#)

HILLSBOROUGH COUNTY LAKES

[Bay Lake](#)
[Bellows \(East\) Lake](#)
[Brant Lake](#)
[Calm Lake](#)
[Lake Carroll](#)
[Cedar Lake](#)
[Cedar Lake \(East\)](#)
[Chapman Lake](#)
[Chapman Lake](#)
[Church Lake](#)
[Crescent Lake](#)
[Lake Cypress](#)
[Deer Lake](#)
[Dosson Lake](#)
[Lake Eckles](#)
[Egypt Lake](#)
[Lake Ellen](#)
[Lake Ellen](#)
[Lake Ellen](#)
[Lake Estes](#)
[Lake Eva](#)
[Gant Lake](#)
[Golden Trout Lake](#)
[Gornito Lake](#)
[Grace Lake](#)
[Halfmoon Lake](#)
[Lake Helen](#)
[Hog Island Lake](#)
[Horse Lake](#)
[Island Ford Lake](#)
[Lake Jackson](#)
[Lake Juanita](#)
[Keystone Lake](#)
[Little Deer Lake](#)
[Little Halfmoon Lake](#)
[Little Moon Lake](#)
[Long Pond](#)
[Lake Magdalene](#)
[Lake Mango](#)
[Marlee Lake](#)
[Mead Lake](#)

HILLSBOROUGH COUNTY LAKES

[Lake Merrywater](#)
[Platt Lake](#)
[Pretty Lake](#)
[Rainbow Lake](#)
[Lake Raleigh](#)
[Lake Reinheimer](#)
[Lake Rogers](#)
[Round Lake](#)
[Sapphire Lake](#)
[Starvation Lake](#)
[Lake Stemper](#)
[Sunset Lake](#)
[Sunshine Lake](#)
[Lake Taylor](#)
[Tenmile Lake](#)
[Thorpe Lake](#)
[Turkey Ford Lake](#)
[Twin Lake](#)
[Valrico Lake](#)
[Wastena Lake](#)
[Lake Weeks](#)
[White Trout Lake](#)
[Williams Lake](#)
[Lake Wimauma](#)
[Wood Lake](#)
[Zambito Lake](#)

LEVY COUNTY LAKE

[Lake Marion](#)

MARION COUNTY LAKES

[Bonable Lake](#)
[Little Bonable Lake](#)
[Little Bream Lake](#)
[Lake Otting](#)
[Tiger Lake](#)

PASCO COUNTY LAKES

[Banjo Lake](#)
[Bell Lake](#)
[Lake Bernadette](#)

PASCO COUNTY LAKES

[Big Lake Vienna](#)
[Bird Lake](#)
[Black Lake](#)
[Blanton Lake](#)
[Crews Lake](#)
[Dowling Lake](#)
[East \(Cow\) Lake](#)
[Fishing Lake](#)
[Floyd Lake](#)
[Gooseneck Lake](#)
[Green Lake](#)
[Lake Hancock](#)
[Hunters Lake](#)
[Lake Iola](#)
[Jessamine Lake](#)
[King Lake](#)
[King \(East\) Lake](#)
[Loyce Lake](#)
[Middle Lake](#)
[Moody Lake \(East\)](#)
[Moody Lake \(West\)](#)
[Moon Lake](#)
[Moss Lake](#)
[Lake Padgett](#)
[Parker Lake](#)
[Lake Pasadena](#)
[Pierce Lake](#)
[Sumner Lake](#)
[Lake Thomas](#)
[Treasure \(Lucy\) Lake](#)
[Turtle \(Tampa\) Lake](#)
[Twin Lake](#)
[Unnamed Pasco Lake](#)
[Vienna Lake](#)
[West Moon Lake](#)
[Wistaria Lake](#)
[Lake Worrell](#)

PINELLAS COUNTY LAKES

[Alligator Lake](#)
[Beckett Lake](#)

PINELLAS COUNTY LAKES

[Bellevue Lake](#)
[Lake Bowden \(Chautauqua\)](#)
[Crescent Lake](#)
[Crest \(Excelsior\) Lake](#)
[Freedom Lake](#)
[Harbor Lake](#)
[Lake Maggiore](#)
[Mirror Lake](#)
[Pasadena Lake](#)
[Sawgrass Lake](#)
[Saint George Lake](#)
[Taylor Lake](#)

POLK COUNTY LAKES

[Lake Agnes](#)
[Lake Alfred](#)
[Lake Ariana](#)
[Lake Arietta](#)
[Lake Bess](#)
[Blue Lake \(Big\)](#)
[Blue Lake \(Little\)](#)
[Lake Bonny](#)
[Lake Buffum](#)
[Lake Cannon](#)
[Lake Clinch](#)
[Lake Conine](#)
[Crooked Lake](#)
[Cypress Lake](#)
[Lake Daisy](#)
[Lake Davenport](#)
[Lake Deeson](#)
[Eagle Lake](#)
[Lake Echo](#)
[Lake Effie](#)
[Lake Elbert](#)
[Lake Eloise](#)
[Lake Fannie](#)
[Gadau Lake](#)
[Lake Galloway \(Hidden\)](#)
[Lake Garfield](#)
[Lake Gibson](#)

POLK COUNTY LAKES

[Lake Gordon](#)
[Lake Gordon \(SW\)](#)
[Lake Haines](#)
[Lake Hamilton](#)
[Lake Hancock](#)
[Lake Hartridge](#)
[Lake Henry](#)
[Lake Hickory](#)
[Lake Howard](#)
[Lake Ida \(Frostproof\)](#)
[Lake Ida \(Winter Haven\)](#)
[Lake Idyl](#)
[Idylwild Lake](#)
[Lake Isabell](#)
[Lake Jessie](#)
[Lake Juliana](#)
[Lake Lena](#)
[Lake Leonore](#)
[Lester Lake](#)
[Little Crooked Lake](#)
[Lake Lulu](#)
[Lake Mabel](#)
[Lake Mattie](#)
[Lake May](#)
[Lake McLeod](#)
[Lake Moody](#)
[Mud Lake](#)
[Lake Myrtle](#)
[Pabor Lake](#)
[Lake Pansy](#)
[Lake Parker](#)
[Reedy Lake](#)
[Lake Rochelle](#)
[Lake Ruby](#)
[Scott Lake](#)
[Lake Shipp](#)
[Spirit Lake](#)
[Lake Starr](#)
[Lake Streety](#)
[Surveyors Lake](#)
[Lake Swoope](#)

POLK COUNTY LAKES

[Lake Tennessee](#)
[Trout Lake](#)
[Lake Van](#)
[Lake Wales](#)
[Lake Winterset](#)

SUMTER COUNTY LAKES

[Big Gant Lake](#)
[Lake Deaton](#)
[Lake Miona](#)
[Lake Okahumpka](#)

Bellamy Lake

Citrus County

USGS Quadrangle: Stokes Ferry Major Land Use/Land Cover (1990)
 Section/Township/Range: 11-18S-19E within 500 meters of the lakeshore:
 Approx. Lake Center, Lat/Long: 285558/822224 - high density residential (27%)
 Surface Area: 34 acres - medium density residential (24%)
 Approx. Lake Elevation: 39 feet - low density residential (23%)
 Average Depth: 10.2 feet
 Observed Maximum Depth: 13 feet
 (reference elevation not given)
 Lake Type: outflow (type 2)
 Major Basin: Withlacoochee River
 Minor Basin: Tsala Apopka Outlet
 Lake Region: Tsala Apopka
 Public Access: yes

Total Number of Samples Collected: 2 Most Recent Sample Collected: January 1997

Parameter	Units (Detection Limit)	Average Value	District Percentile	Florida Percentile
Chlorophyll a	ug/l (1)	3.0	25	13
Total Phosphorus	mg/l as P (0.01)	0.018	61	9
Total Nitrogen	mg/l as N (0.06)	0.52	6	11
Transparency (Secchi depth)	meters	2.30	71	90
Florida Trophic State Index		26	18	<5
Specific Conductance	S/cm at 25C (1)	108	15	26
pH	standard units (0.1)	7.2	43	40
Color	PtCo units (1)	30	67	23
Turbidity	NTU (1)	0.5	28	<5
Total Alkalinity	mg/l as CaCO3 (1)	36	67	53
Hardness	mg/l as CaCO3 (0.02)	37	30	
Total Suspended Solids	mg/l (0.05)	0.2	<5	
Ammonia	mg/l as N (0.03)	0.015	60	
Nitrate+Nitrite	mg/l as N (0.01)	0.014	42	
Total Kjeldahl Nitrogen	mg/l as N (0.06)	0.52	9	
Orthophosphorus	mg/l as P (0.01)	0.005	56	
Chloride	mg/l (0.05)	12	23	
Sulfate	mg/l (0.05)	0	<5	
Sodium	mg/l (0.06)	7.9	43	
Potassium	mg/l (0.07)	0.2	<5	
Calcium	mg/l (0.04)	13.0	53	
Magnesium	mg/l (0.006)	1.2	10	
Iron	ug/l (0.03)	57	66	

Bellamy Lake is in the Hernando Pool of the Lake Tsala Apopka chain. Based upon the average FTSI of 26, water quality is considered good. Bellamy Lake can be characterized as a moderately colored, soft water, oligo-mesotrophic lake. The chemical type of water (predominant ionic composition) is calcium bicarbonate.

Also of note:

- Hydrilla was observed in the lake.

Plots and Trends: The plot of lake elevation is for the Hernando Pool of Lake Tsala Apopka. No trend in elevation is evident. Also shown is a diagram of the relative ionic composition of the lake water.

MONTHLY AVERAGE SURFACE ELEVATION

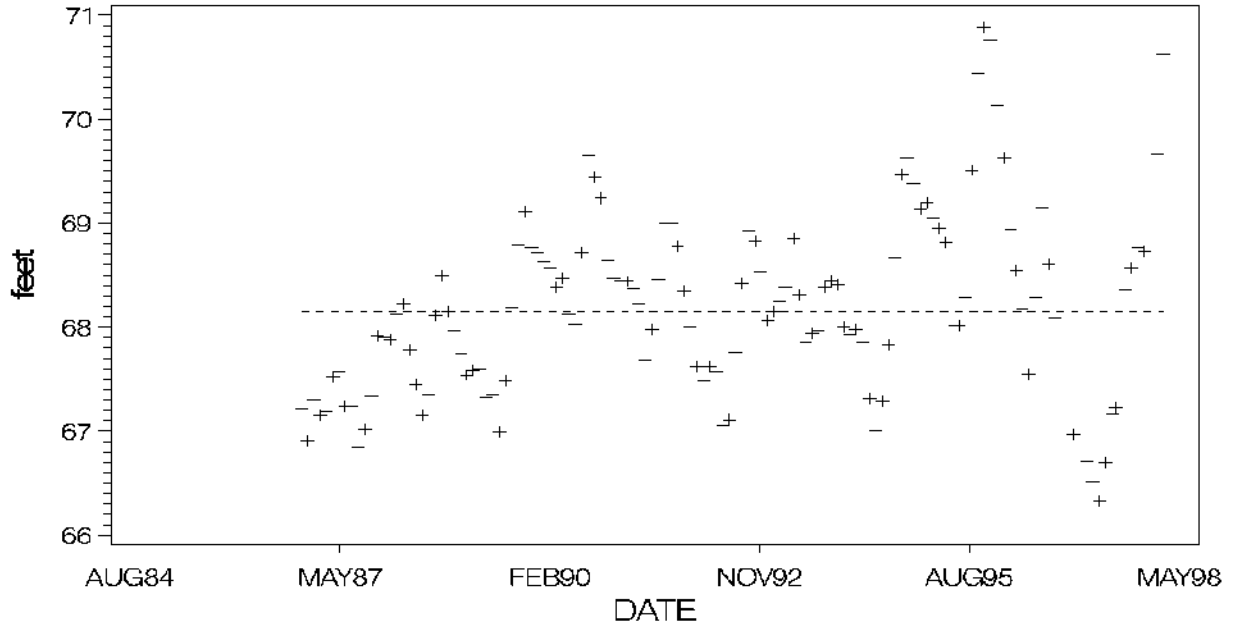

MAJOR IONS (% meq/l)

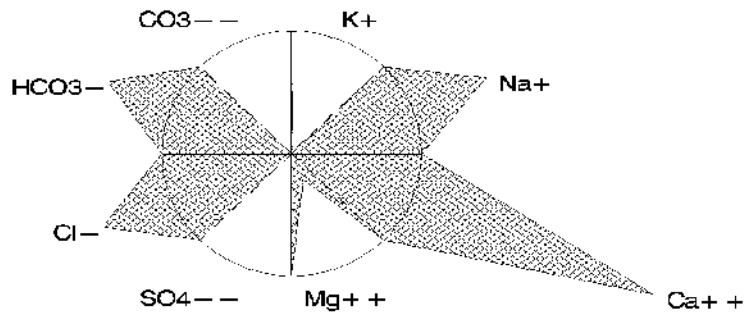

Cato Lake

Citrus County

USGS Quadrangle: Inverness Major Land Use/Land Cover (1990)
 Section/Township/Range: 5-19S-20E within 500 meters of the lakeshore:
 Approx. Lake Center, Lat/Long: 285200/821948 - cropland and pastureland (25%)
 Surface Area: 103 acres - hardwood - conifer mixed (24%)
 Approx. Lake Elevation: 38 feet - longleaf pine - xeric pine (19%)
 Lake Type: isolated (type 4)
 Major Basin: Withlacoochee River
 Minor Basin: Tsala Apopka Outlet
 Lake Region: Tsala Apopka

Total Number of Samples Collected: 1 Most Recent Sample Collected: August 1996

Parameter	Units (Detection Limit)	Average Value	District Percentile	Florida Percentile
Chlorophyll a	ug/l (1)	4.6	41	19
Total Phosphorus	mg/l as P (0.01)	0.020	65	10
Total Nitrogen	mg/l as N (0.06)	1.50	69	60
Transparency (Secchi depth)	meters	-	-	-
Florida Trophic State Index		39	51	14
Specific Conductance	S/cm at 25C (1)	327	91	71
pH	standard units (0.1)	6.8	25	25
Color	PtCo units (1)	50	79	40
Turbidity	NTU (1)	1.3	36	10
Total Alkalinity	mg/l as CaCO3 (1)	164	>95	>95
Hardness	mg/l as CaCO3 (0.02)	132	>95	>95
Total Suspended Solids	mg/l (0.05)	1.3	35	
Ammonia	mg/l as N (0.03)	0.015	60	
Nitrate+Nitrite	mg/l as N (0.01)	0.005	33	
Total Kjeldahl Nitrogen	mg/l as N (0.06)	1.50	77	
Orthophosphorus	mg/l as P (0.01)	0.016	82	
Chloride	mg/l (0.05)	14	30	
Sulfate	mg/l (0.05)	1	6	
Sodium	mg/l (0.06)	14.0	80	
Potassium	mg/l (0.07)	0.4	9	
Calcium	mg/l (0.04)	50.0	>95	
Magnesium	mg/l (0.006)	1.8	22	
Iron	ug/l (0.03)	350	>95	

Based upon the average FTSI of 39, water quality is considered good. Cato Lake can be characterized as a colored, hard water, mesotrophic lake. The chemical type of water (predominant ionic composition) is calcium bicarbonate.

Plots and Trends: No or insufficient data for plotting or trend detection. Shown is a diagram of the relative ionic composition of the lake water.

MAJOR IONS (% meq/l)

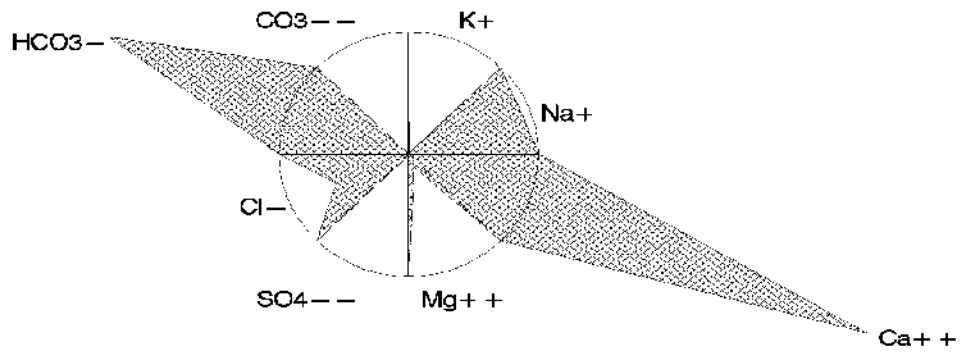

Cato Lake, Citrus County

Connell Lake Citrus County

USGS Quadrangle:	Inverness	Major Land Use/Land Cover (1990)
Section/Township/Range:	6-19S-20E	within 500 meters of the lakeshore:
Approx. Lake Center, Lat/Long:	285212/822114	- hardwood - conifer mixed (38%)
Surface Area:	173 acres	- low density residential (13%)
Approx. Lake Elevation:	36 feet	- recreational (12%)
Lake Type:	isolated (type 4)	
Major Basin:	Withlacoochee River	
Minor Basin:	Tsala Apopka Outlet	
Lake Region:	Tsala Apopka	

Total Number of Samples Collected: 2 Most Recent Sample Collected: January 1997

Parameter	Units (Detection Limit)	Average Value	District Percentile	Florida Percentile
Chlorophyll a	ug/l (1)	1.5	5	5
Total Phosphorus	mg/l as P (0.01)	0.010	33	5
Total Nitrogen	mg/l as N (0.06)	1.12	50	37
Transparency (Secchi depth)	meters	2.63	78	93
Florida Trophic State Index		20	6	<5
Specific Conductance	S/cm at 25C (1)	147	36	41
pH	standard units (0.1)	7.3	50	45
Color	PtCo units (1)	25	62	20
Turbidity	NTU (1)	0.8	28	<5
Total Alkalinity	mg/l as CaCO3 (1)	65	89	70
Hardness	mg/l as CaCO3 (0.02)	66	69	
Total Suspended Solids	mg/l (0.05)	0.4	8	
Ammonia	mg/l as N (0.03)	0.015	60	
Nitrate+Nitrite	mg/l as N (0.01)	0.005	33	
Total Kjeldahl Nitrogen	mg/l as N (0.06)	1.12	56	
Orthophosphorus	mg/l as P (0.01)	0.012	68	
Chloride	mg/l (0.05)	5	<5	
Sulfate	mg/l (0.05)	1	6	
Sodium	mg/l (0.06)	5.6	18	
Potassium	mg/l (0.07)	0.1	<5	
Calcium	mg/l (0.04)	24.5	87	
Magnesium	mg/l (0.006)	1.1	8	
Iron	ug/l (0.03)	42	55	

Based upon the average FTSI of 20, water quality is considered good. Connell Lake can be characterized as a moderately colored, medium hard water, oligotrophic lake. The chemical type of water (predominant ionic composition) is calcium bicarbonate.

Plots and Trends: No or insufficient data for plotting or trend detection. Shown is a diagram of the relative ionic composition of the lake water.

MAJOR IONS (% meq/l)

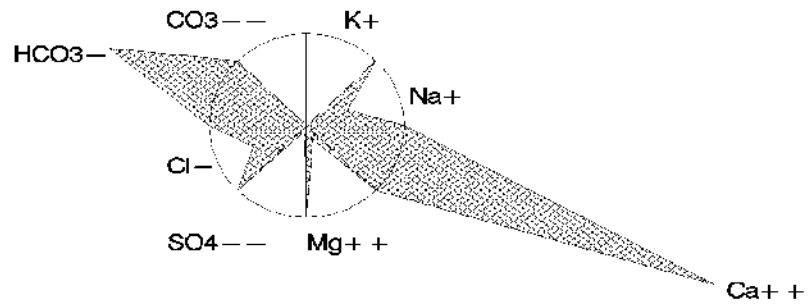

Cooter Lake

Citrus County

USGS Quadrangle: Inverness Major Land Use/Land Cover (1990)
 Section/Township/Range: 17-19S-20E within 500 meters of the lakeshore:
 Approx. Lake Center, Lat/Long: 285005/821938 - commercial and services (35%)
 Surface Area: 24 acres - medium density residential (27%)
 Approx. Lake Elevation: 41 feet - hardwood - conifer mixed (14%)
 Average Depth: 6.6 feet
 Observed Maximum Depth: 10 feet
 (reference elevation 39.9 feet)
 Lake Type: outflow (type 2)
 Major Basin: Withlacoochee River
 Minor Basin: Tsala Apopka Outlet
 Lake Region: Tsala Apopka

Total Number of Samples Collected: 2 Most Recent Sample Collected: January 1997

Parameter	Units (Detection Limit)	Average Value	District Percentile	Florida Percentile
Chlorophyll a	ug/l (1)	1.7	8	6
Total Phosphorus	mg/l as P (0.01)	0.008	31	<5
Total Nitrogen	mg/l as N (0.06)	0.62	12	16
Transparency (Secchi depth)	meters	-	-	-
Florida Trophic State Index		17	<5	<5
Specific Conductance	S/cm at 25C (1)	160	42	44
pH	standard units (0.1)	7.8	74	63
Color	PtCo units (1)	8	24	8
Turbidity	NTU (1)	0.5	28	<5
Total Alkalinity	mg/l as CaCO3 (1)	75	94	75
Hardness	mg/l as CaCO3 (0.02)	75	75	
Total Suspended Solids	mg/l (0.05)	0.1	<5	
Ammonia	mg/l as N (0.03)	0.025	60	
Nitrate+Nitrite	mg/l as N (0.01)	0.005	33	
Total Kjeldahl Nitrogen	mg/l as N (0.06)	0.61	16	
Orthophosphorus	mg/l as P (0.01)	0.011	64	
Chloride	mg/l (0.05)	4	<5	
Sulfate	mg/l (0.05)	1	6	
Sodium	mg/l (0.06)	4.2	10	
Potassium	mg/l (0.07)	0.3	7	
Calcium	mg/l (0.04)	28.7	90	
Magnesium	mg/l (0.006)	0.7	<5	
Iron	ug/l (0.03)	57	67	

Based upon the average FTSI of 17, water quality is considered good. Cooter Lake can be characterized as a clear (color<=10 color units), medium hard water, mesotrophic lake, with low concentrations of total nitrogen. The chemical type of water (predominant ionic composition) is calcium bicarbonate.

Plots and Trends: No or insufficient data for plotting or trend detection. Shown is a diagram of the relative ionic composition of the lake water.

MAJOR IONS (% meq/l)

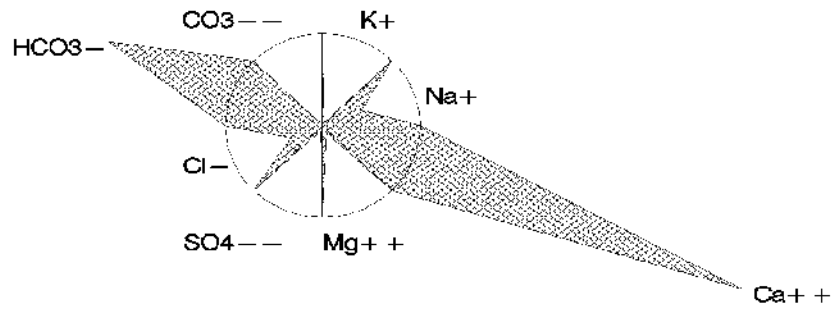

Croft Lake

Citrus County

USGS Quadrangle: Stokes Ferry Major Land Use/Land Cover (1990)
 Section/Township/Range: 30-18S-20E within 500 meters of the lakeshore:
 Approx. Lake Center, Lat/Long: 285339/822059 - medium density residential (25%)
 Surface Area: 302 acres - cropland and pastureland (23%)
 Approx. Lake Elevation: 39 feet - specialty farms inc. horse, dairy,
 Average Depth: 7.9 feet kennels (19%)
 (reference elevation 37 feet)
 Lake Type: inflow and outflow (type 3)
 Major Basin: Withlacoochee River
 Minor Basin: Tsala Apopka Outlet
 Lake Region: Tsala Apopka
 Public Access: yes

Total Number of Samples Collected: 2 Most Recent Sample Collected: January 1997

Parameter	Units (Detection Limit)	Average Value	District Percentile	Florida Percentile
Chlorophyll a	ug/l (1)	2.6	19	11
Total Phosphorus	mg/l as P (0.01)	0.005	31	<5
Total Nitrogen	mg/l as N (0.06)	0.62	12	16
Transparency (Secchi depth)	meters	2.25	70	89
Florida Trophic State Index		22	9	<5
Specific Conductance	S/cm at 25C (1)	111	16	28
pH	standard units (0.1)	7.5	61	53
Color	PtCo units (1)	45	76	35
Turbidity	NTU (1)	0.5	28	<5
Total Alkalinity	mg/l as CaCO3 (1)	35	66	53
Hardness	mg/l as CaCO3 (0.02)	46	48	
Total Suspended Solids	mg/l (0.05)	0.2	<5	
Ammonia	mg/l as N (0.03)	0.015	60	
Nitrate+Nitrite	mg/l as N (0.01)	0.010	34	
Total Kjeldahl Nitrogen	mg/l as N (0.06)	0.62	17	
Orthophosphorus	mg/l as P (0.01)	0.005	56	
Chloride	mg/l (0.05)	10	15	
Sulfate	mg/l (0.05)	1	6	
Sodium	mg/l (0.06)	6.0	22	
Potassium	mg/l (0.07)	0.7	14	
Calcium	mg/l (0.04)	16.4	63	
Magnesium	mg/l (0.006)	1.3	12	
Iron	ug/l (0.03)	33	44	

Croft Lake is in the Hernando Pool of the Lake Tsala Apopka chain. Based upon the average FTSI of 22, water quality is considered good. Croft Lake can be characterized as a colored, soft water, oligotrophic lake, with low concentrations of total phosphorus. The chemical type of water (predominant ionic composition) is calcium bicarbonate.

Plots and Trends: The plot of lake surface elevation is for the Hernando Pool of Lake Tsala Apopka. There are no trends in lake level for the period of record. Also shown is a diagram of the relative ionic composition of the lake water.

MONTHLY AVERAGE SURFACE ELEVATION

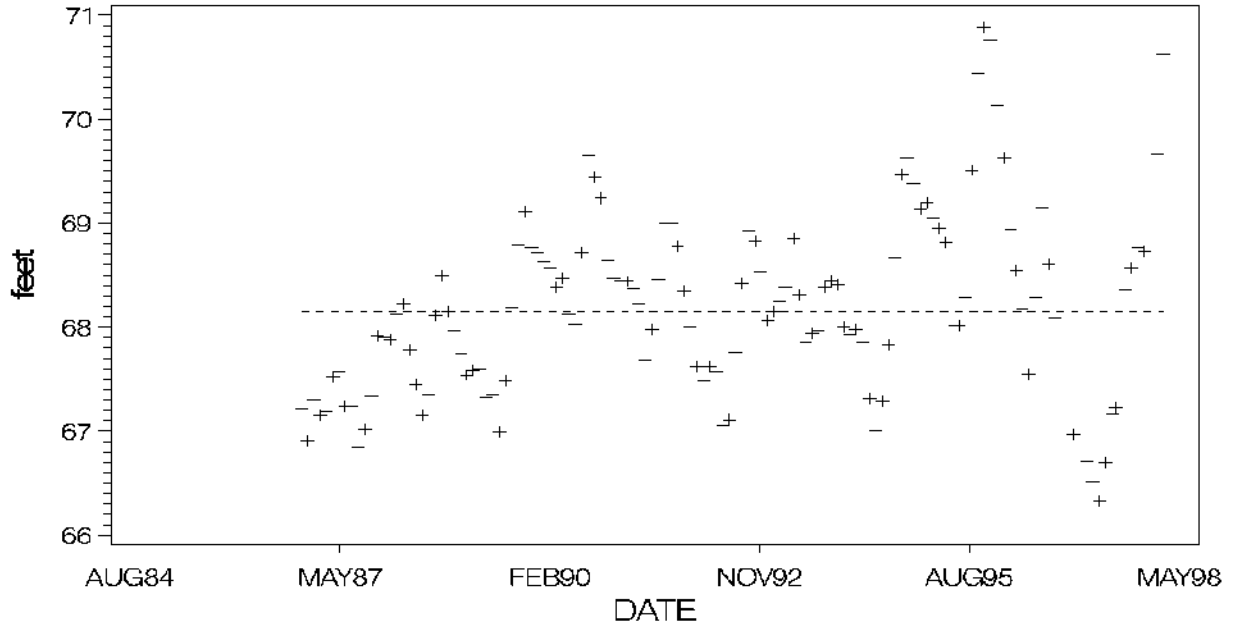

MAJOR IONS (% meq/l)

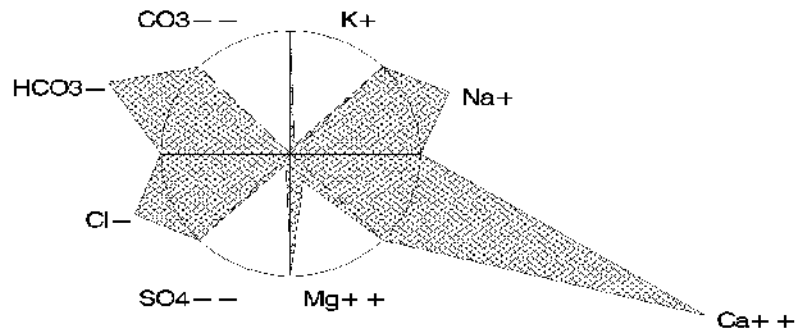

Croft Lake, Citrus County

Davis Lake

Citrus County

USGS Quadrangle: Inverness Major Land Use/Land Cover (1990)
 Section/Township/Range: 22-19S-20E within 500 meters of the lakeshore:
 Approx. Lake Center, Lat/Long: 284918/821712 - medium density residential (25%)
 Surface Area: 145 acres - freshwater marshes (13%)
 Approx. Lake Elevation: 41 feet - low density residential (13%)
 Lake Type: inflow and outflow (type 3)
 Major Basin: Withlacoochee River
 Minor Basin: Tsala Apopka Outlet
 Lake Region: Tsala Apopka
 Public Access: yes

Total Number of Samples Collected: 2 Most Recent Sample Collected: January 1997

Parameter	Units (Detection Limit)	Average Value	District Percentile	Florida Percentile
Chlorophyll a	ug/l (1)	15.8	75	46
Total Phosphorus	mg/l as P (0.01)	0.005	31	<5
Total Nitrogen	mg/l as N (0.06)	1.12	50	37
Transparency (Secchi depth)	meters	1.21	40	70
Florida Trophic State Index		37	46	11
Specific Conductance	S/cm at 25C (1)	146	35	41
pH	standard units (0.1)	7.7	69	60
Color	PtCo units (1)	93	88	74
Turbidity	NTU (1)	1.6	44	14
Total Alkalinity	mg/l as CaCO3 (1)	53	81	64
Hardness	mg/l as CaCO3 (0.02)	69	71	
Total Suspended Solids	mg/l (0.05)	1.5	39	
Ammonia	mg/l as N (0.03)	0.023	60	
Nitrate+Nitrite	mg/l as N (0.01)	0.011	37	
Total Kjeldahl Nitrogen	mg/l as N (0.06)	1.12	56	
Orthophosphorus	mg/l as P (0.01)	0.005	56	
Chloride	mg/l (0.05)	11	19	
Sulfate	mg/l (0.05)	1	6	
Sodium	mg/l (0.06)	5.8	20	
Potassium	mg/l (0.07)	0.8	16	
Calcium	mg/l (0.04)	24.7	87	
Magnesium	mg/l (0.006)	1.7	20	
Iron	ug/l (0.03)	108	84	

Davis Lake is in the Inverness Pool of the Lake Tsala Apopka chain. Based upon the average FTSI of 37, water quality is considered good. Davis Lake can be characterized as a highly colored, medium hard water, eutrophic lake, with low concentrations of total phosphorus. The chemical type of water (predominant ionic composition) is calcium bicarbonate.

Also of note:

- Cattails dominate more than 30% of the lake shoreline.

Plots and Trends: The plot of lake elevation is for the Inverness Pool of Lake Tsala Apopka. No trend in elevation is evident. Also shown is a diagram of the relative ionic composition of the lake water.

MONTHLY AVERAGE SURFACE ELEVATION

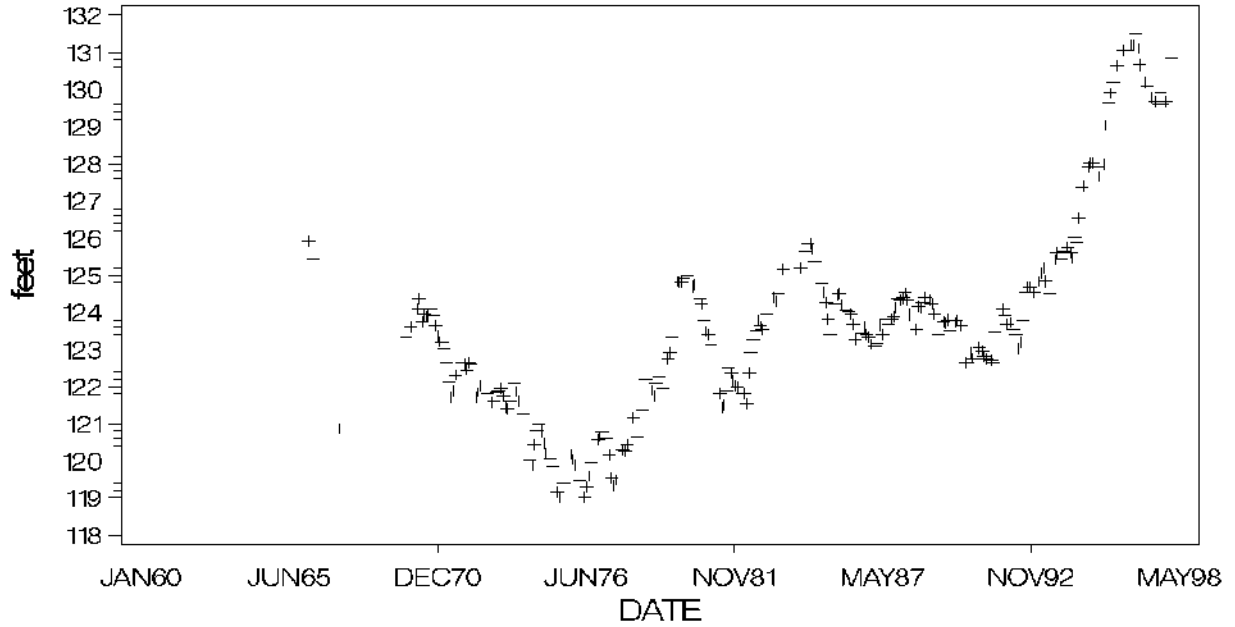

MAJOR IONS (% meq/l)

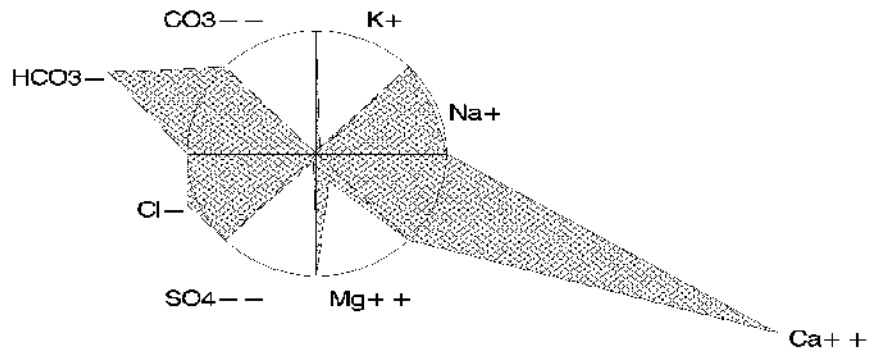

Dodd Lake

Citrus County

USGS Quadrangle: Stokes Ferry Major Land Use/Land Cover (1990)
 Section/Township/Range: 11-18S-19E within 500 meters of the lakeshore:
 Approx. Lake Center, Lat/Long: 285631/822221 - low density residential (28%)
 Surface Area: 106 acres - medium density residential (18%)
 Approx. Lake Elevation: 39 feet - cropland and pastureland (12%)
 Average Depth: 10.2 feet
 Observed Maximum Depth: 16 feet
 (reference elevation not given)
 Lake Type: inflow and outflow (type 3)
 Major Basin: Withlacoochee River
 Minor Basin: Tsala Apopka Outlet
 Lake Region: Tsala Apopka
 Public Access: yes

Total Number of Samples Collected: 2 Most Recent Sample Collected: January 1997

Parameter	Units (Detection Limit)	Average Value	District Percentile	Florida Percentile
Chlorophyll a	ug/l (1)	3.6	32	15
Total Phosphorus	mg/l as P (0.01)	0.031	77	21
Total Nitrogen	mg/l as N (0.06)	0.72	19	21
Transparency (Secchi depth)	meters	2.31	72	90
Florida Trophic State Index		21	8	<5
Specific Conductance	S/cm at 25C (1)	92	11	20
pH	standard units (0.1)	7.3	50	45
Color	PtCo units (1)	25	62	20
Turbidity	NTU (1)	0.5	28	<5
Total Alkalinity	mg/l as CaCO3 (1)	36	67	53
Hardness	mg/l as CaCO3 (0.02)	42	39	
Total Suspended Solids	mg/l (0.05)	0.3	<5	
Ammonia	mg/l as N (0.03)	0.015	60	
Nitrate+Nitrite	mg/l as N (0.01)	0.011	37	
Total Kjeldahl Nitrogen	mg/l as N (0.06)	0.72	25	
Orthophosphorus	mg/l as P (0.01)	0.005	56	
Chloride	mg/l (0.05)	10	15	
Sulfate	mg/l (0.05)	0	<5	
Sodium	mg/l (0.06)	6.2	24	
Potassium	mg/l (0.07)	0.2	<5	
Calcium	mg/l (0.04)	15.0	60	
Magnesium	mg/l (0.006)	1.0	6	
Iron	ug/l (0.03)	19	18	

Dodd Lake is in the Hernando Pool of the Lake Tsala Apopka chain. Based upon the average FTSI of 21, water quality is considered good. Dodd Lake can be characterized as a moderately colored, soft water, oligo-mesotrophic lake. The chemical type of water (predominant ionic composition) is calcium bicarbonate.

Plots and Trends: The plot of lake elevation is for the Hernando Pool of Lake Tsala Apopka. No trend in elevation is evident. Also shown is a diagram of the relative ionic composition of the lake water.

MONTHLY AVERAGE SURFACE ELEVATION

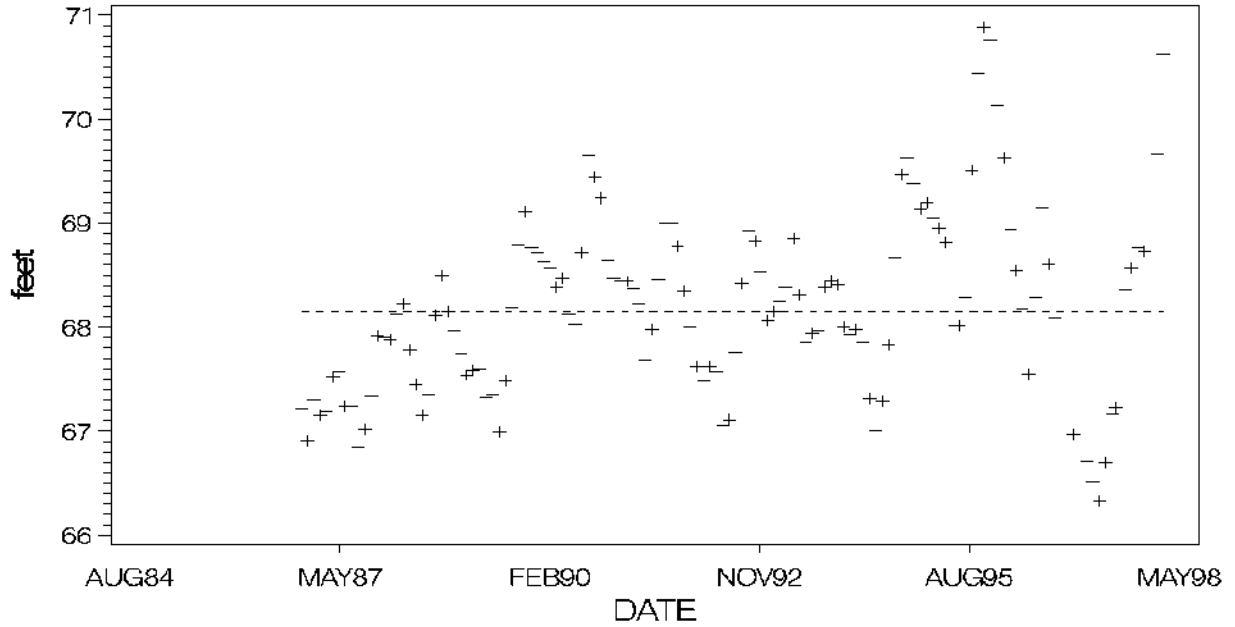

MAJOR IONS (% meq/l)

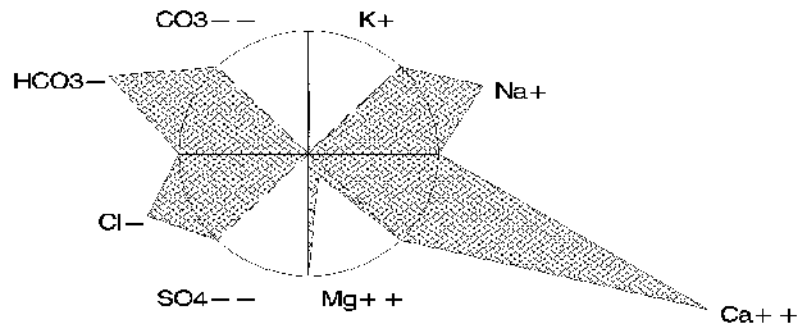

Floral City Lake

Citrus County

USGS Quadrangle:	Inverness	Major Land Use/Land Cover (1990)
Section/Township/Range:	11-20S-20E	within 500 meters of the lakeshore:
Approx. Lake Center, Lat/Long:	284630/821705	- medium density residential (22%)
Surface Area:	346 acres	- freshwater marshes (13%)
Approx. Lake Elevation:	43 feet	- cropland and pastureland (13%)
Average Depth: 8.5 feet		
Observed Maximum Depth: 12 feet (reference elevation not given)		
Lake Type: inflow and outflow (type 3)		
Major Basin: Withlacoochee River		
Minor Basin: Tsala Apopka Outlet		
Lake Region: Tsala Apopka		
Public Access: yes		

Total Number of Samples Collected: 9 Most Recent Sample Collected: January 1997

Parameter	Units (Detection Limit)	Average Value	District Percentile	Florida Percentile
Chlorophyll a	ug/l (1)	10.3	65	38
Total Phosphorus	mg/l as P (0.01)	0.040	83	30
Total Nitrogen	mg/l as N (0.06)	1.16	52	39
Transparency (Secchi depth)	meters	1.68	55	80
Florida Trophic State Index		49	71	33
Specific Conductance	S/cm at 25C (1)	206	62	53
pH	standard units (0.1)	7.5	61	53
Color	PtCo units (1)	162	95	92
Turbidity	NTU (1)	1.9	49	19
Total Alkalinity	mg/l as CaCO3 (1)	66	90	71
Hardness	mg/l as CaCO3 (0.02)	77	77	
Total Suspended Solids	mg/l (0.05)	1.3	35	
Ammonia	mg/l as N (0.03)	0.037	66	
Nitrate+Nitrite	mg/l as N (0.01)	0.049	69	
Total Kjeldahl Nitrogen	mg/l as N (0.06)	1.12	56	
Orthophosphorus	mg/l as P (0.01)	0.016	82	
Chloride	mg/l (0.05)	15	34	
Sulfate	mg/l (0.05)	1	6	
Sodium	mg/l (0.06)	6.4	25	
Potassium	mg/l (0.07)	0.9	17	
Calcium	mg/l (0.04)	30.0	93	
Magnesium	mg/l (0.006)	2.1	28	
Iron	ug/l (0.03)	193	91	

Floral City Lake is in the Floral City Pool of the Lake Tsala Apopka chain. Based upon the average FTSI of 49, water quality is considered good. Floral City Lake can be characterized as a highly colored, medium hard water, meso-eutrophic lake, with high concentrations of total phosphorus. The chemical type of water (predominant ionic composition) is calcium bicarbonate.

Plots and Trends: The plot of lake elevation is for the Floral City Pool of Lake Tsala Apopka. No trend in elevation is evident. Measures of water chemistry have also been stable over their respective periods of record. Also shown is a diagram of the relative ionic composition of the lake water.

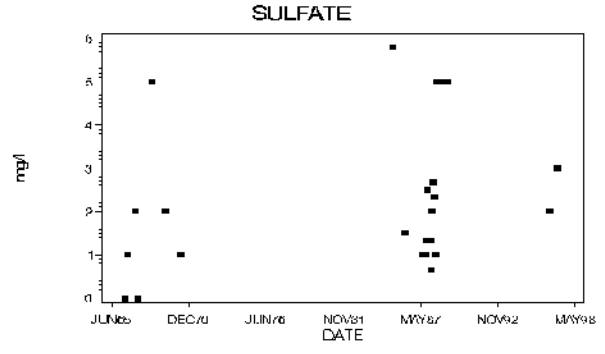
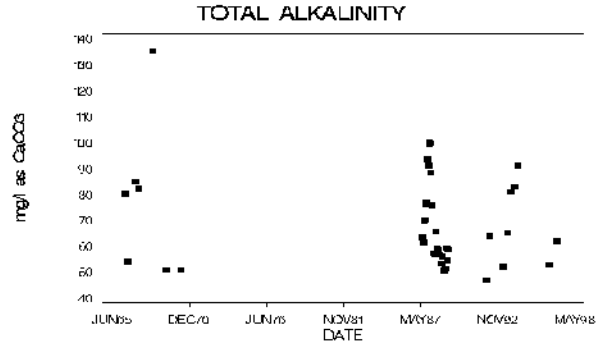
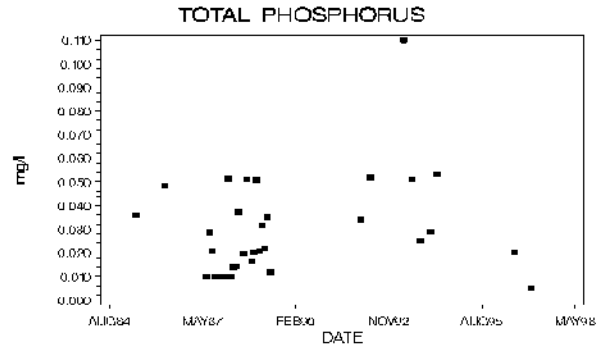
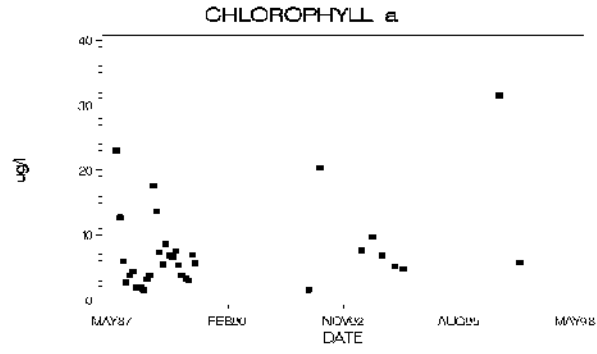
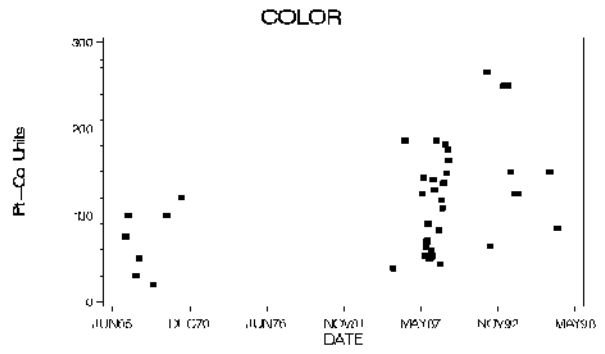
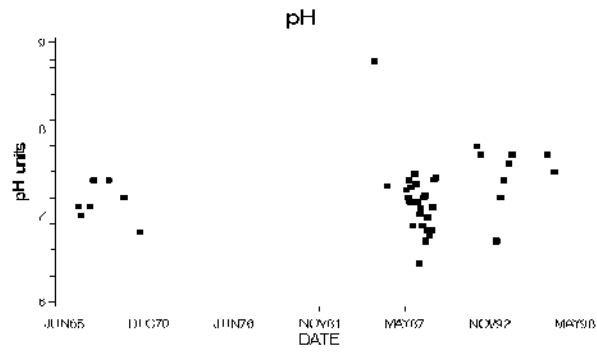
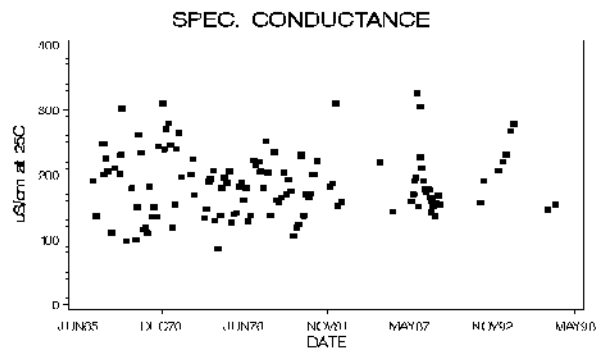
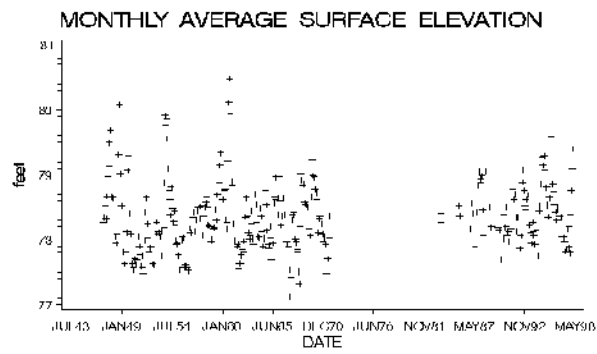

Floral City Lake, Citrus County

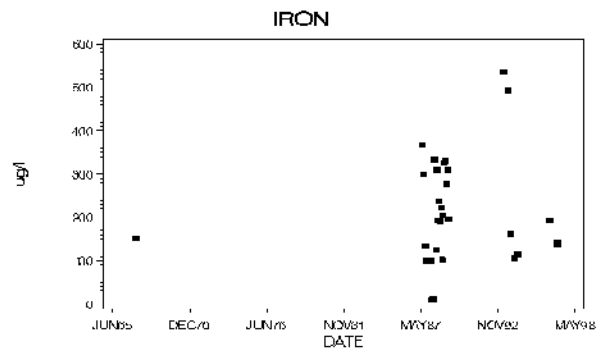
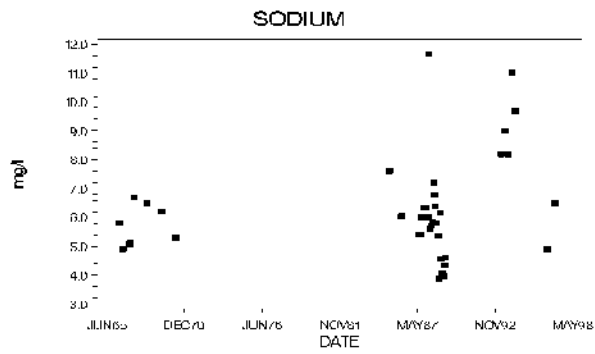
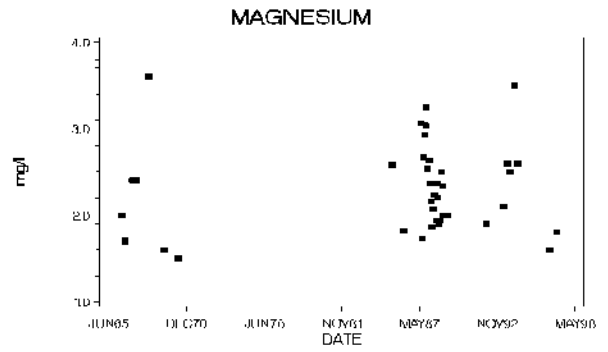
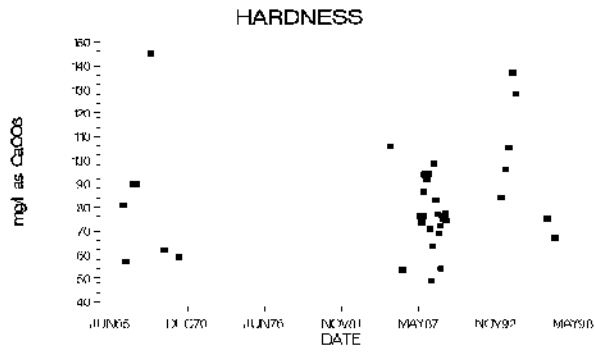
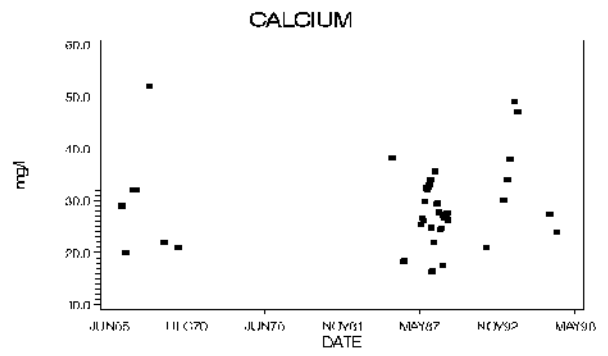
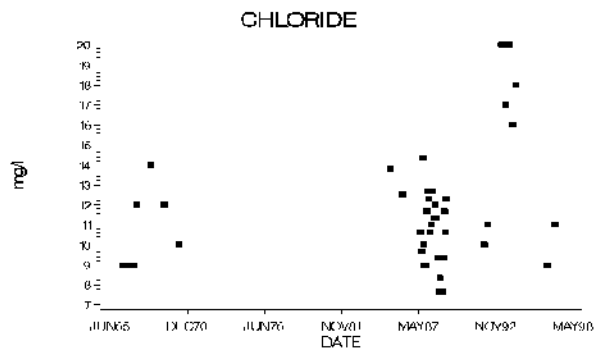

MAJOR IONS (% meq/l)

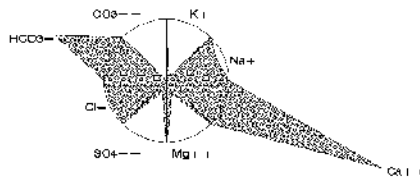

Floral City Lake, Citrus County

Fort Cooper Lake

Citrus County

USGS Quadrangle: Inverness Major Land Use/Land Cover (1990)
 Section/Township/Range: 27-19S-20E within 500 meters of the lakeshore:
 Approx. Lake Center, Lat/Long: 284818/821813 - hardwood - conifer mixed (32%)
 Surface Area: 150 acres - stream and lake swamps (21%)
 Approx. Lake Elevation: 33 feet - freshwater marshes (15%)
 Lake Type: isolated (type 4)
 Major Basin: Withlacoochee River
 Minor Basin: Tsala Apopka Outlet
 Lake Region: Tsala Apopka
 Public Access: yes

Total Number of Samples Collected: 2 Most Recent Sample Collected: January 1996

Parameter	Units (Detection Limit)	Average Value	District Percentile	Florida Percentile
Chlorophyll a	ug/l (1)	1.8	10	7
Total Phosphorus	mg/l as P (0.01)	0.017	58	9
Total Nitrogen	mg/l as N (0.06)	1.96	84	81
Transparency (Secchi depth)	meters	2.27	71	90
Florida Trophic State Index		34	37	8
Specific Conductance	S/cm at 25C (1)	265	82	63
pH	standard units (0.1)	7.4	57	50
Color	PtCo units (1)	35	70	27
Turbidity	NTU (1)	0.5	28	<5
Total Alkalinity	mg/l as CaCO3 (1)	108	>95	90
Hardness	mg/l as CaCO3 (0.02)	117	94	
Total Suspended Solids	mg/l (0.05)	0.4	8	
Ammonia	mg/l as N (0.03)	0.054	78	
Nitrate+Nitrite	mg/l as N (0.01)	0.009	33	
Total Kjeldahl Nitrogen	mg/l as N (0.06)	1.96	89	
Orthophosphorus	mg/l as P (0.01)	0.009	56	
Chloride	mg/l (0.05)	15	34	
Sulfate	mg/l (0.05)	3	14	
Sodium	mg/l (0.06)	8.8	50	
Potassium	mg/l (0.07)	0.1	<5	
Calcium	mg/l (0.04)	43.5	>95	
Magnesium	mg/l (0.006)	1.9	23	
Iron	ug/l (0.03)	40	53	

Based upon the average FTSI of 34, water quality is considered good. Fort Cooper Lake can be characterized as a moderately colored, medium hard water, oligotrophic lake, with high concentrations of total nitrogen. The chemical type of water (predominant ionic composition) is calcium bicarbonate.

Plots and Trends: No or insufficient data available for plotting or trend detection. Shown is a diagram of the relative ionic composition of the lake water.

MAJOR IONS (% meq/l)

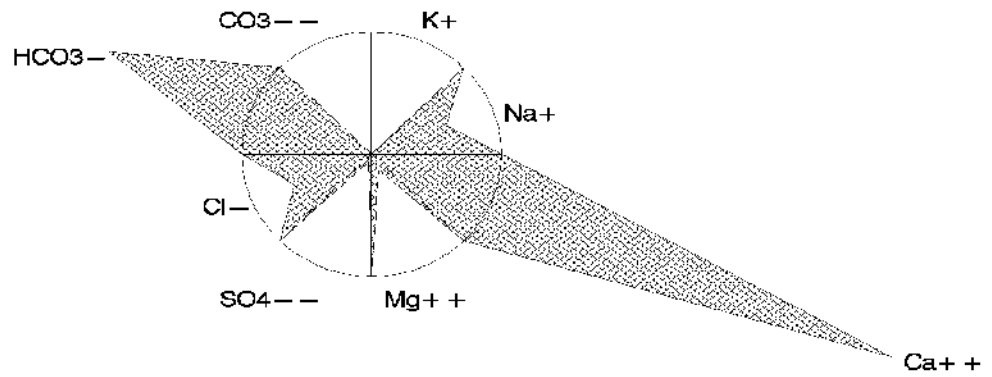

Hampton Lake

Citrus County

USGS Quadrangle: Inverness Major Land Use/Land Cover (1990)
 Section/Township/Range: 2-20S-20E within 500 meters of the lakeshore:
 Approx. Lake Center, Lat/Long: 284653/821700 - hardwood - conifer mixed (33%)
 Surface Area: 69 acres - medium density residential (13%)
 Approx. Lake Elevation: 43 feet - cropland and pastureland (13%)
 Average Depth: 10.5 feet
 (reference elevation 36 feet)
 Lake Type: inflow and outflow (type 3)
 Major Basin: Withlacoochee River
 Minor Basin: Tsala Apopka Outlet
 Lake Region: Tsala Apopka
 Public Access: yes

Total Number of Samples Collected: 2 Most Recent Sample Collected: January 1997

Parameter	Units (Detection Limit)	Average Value	District Percentile	Florida Percentile
Chlorophyll a	ug/l (1)	14.3	73	44
Total Phosphorus	mg/l as P (0.01)	0.005	31	<5
Total Nitrogen	mg/l as N (0.06)	0.92	34	31
Transparency (Secchi depth)	meters	1.24	41	71
Florida Trophic State Index		35	39	9
Specific Conductance	S/cm at 25C (1)	132	26	36
pH	standard units (0.1)	7.4	57	50
Color	PtCo units (1)	105	90	79
Turbidity	NTU (1)	2.6	59	28
Total Alkalinity	mg/l as CaCO3 (1)	49	79	62
Hardness	mg/l as CaCO3 (0.02)	63	65	
Total Suspended Solids	mg/l (0.05)	1.8	47	
Ammonia	mg/l as N (0.03)	0.553	>95	
Nitrate+Nitrite	mg/l as N (0.01)	0.015	44	
Total Kjeldahl Nitrogen	mg/l as N (0.06)	0.92	40	
Orthophosphorus	mg/l as P (0.01)	0.005	56	
Chloride	mg/l (0.05)	9	12	
Sulfate	mg/l (0.05)	2	10	
Sodium	mg/l (0.06)	5.2	14	
Potassium	mg/l (0.07)	0.9	17	
Calcium	mg/l (0.04)	22.7	83	
Magnesium	mg/l (0.006)	1.5	16	
Iron	ug/l (0.03)	127	87	

Hampton Lake is in the Floral City Pool of the Lake Tsala Apopka chain. Based upon the average FTSI of 35, water quality is considered good. Hampton Lake can be characterized as a highly colored, medium hard water, meso-eutrophic lake, with low concentrations of total phosphorus. The chemical type of water (predominant ionic composition) is calcium bicarbonate.

Plots and Trends: The plot of lake elevation is for the Floral City Pool of Lake Tsala Apopka. No trend in elevation is evident. Also shown is a diagram of the relative ionic composition of the lake water.

MONTHLY AVERAGE SURFACE ELEVATION

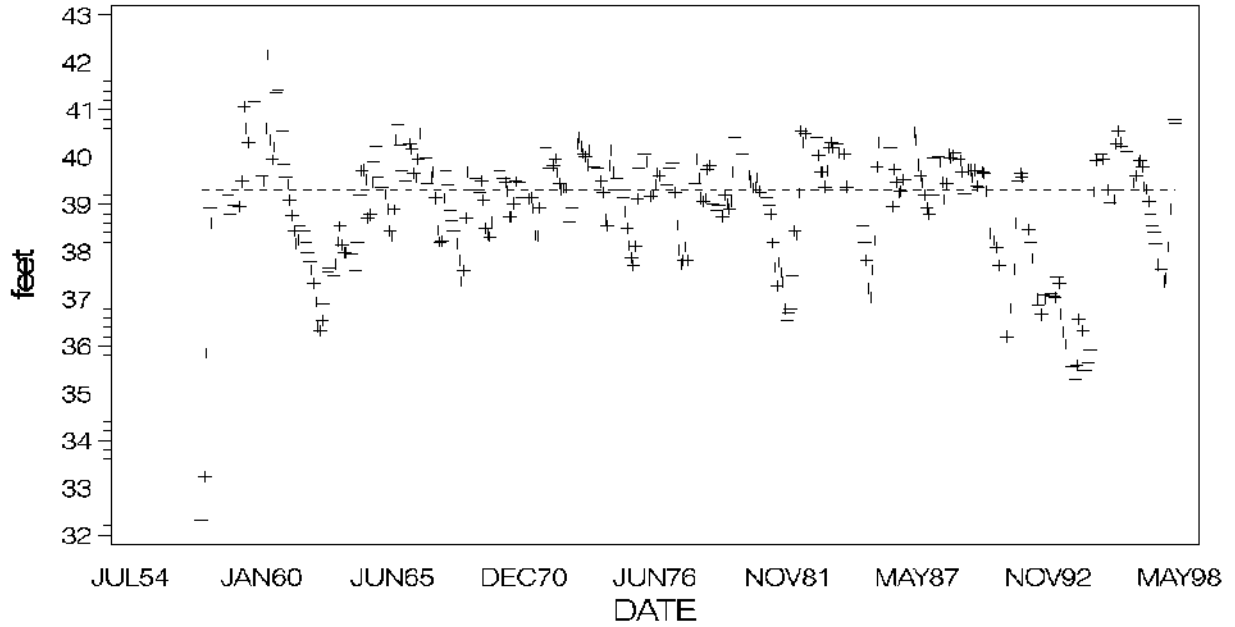

MAJOR IONS (% meq/l)

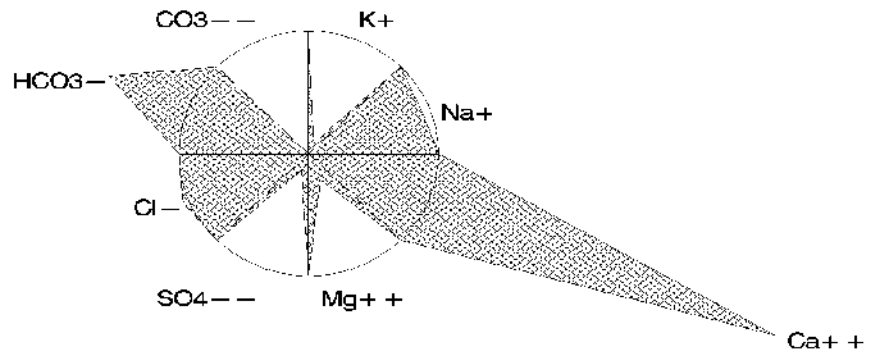

Hampton Lake, Citrus County

Henderson Lake

Citrus County

USGS Quadrangle: Inverness Major Land Use/Land Cover (1990)
 Section/Township/Range: 16-19S-20E within 500 meters of the lakeshore:
 Approx. Lake Center, Lat/Long: 285021/821901 - medium density residential (35%)
 Surface Area: 232 acres - high density residential (11%)
 Approx. Lake Elevation: 41 feet - hardwood - conifer mixed (10%)
 Average Depth: 10.8 feet
 (reference elevation 41 feet)
 Lake Type: inflow and outflow (type 3)
 Major Basin: Withlacoochee River
 Minor Basin: Tsala Apopka Outlet
 Lake Region: Tsala Apopka
 Public Access: yes

Total Number of Samples Collected: 12 Most Recent Sample Collected: January 1997

Parameter	Units (Detection Limit)	Average Value	District Percentile	Florida Percentile
Chlorophyll a	ug/l (1)	6.7	52	29
Total Phosphorus	mg/l as P (0.01)	0.026	73	16
Total Nitrogen	mg/l as N (0.06)	0.76	24	23
Transparency (Secchi depth)	meters	1.95	62	84
Florida Trophic State Index		36	44	11
Specific Conductance	S/cm at 25C (1)	157	41	43
pH	standard units (0.1)	8.0	81	70
Color	PtCo units (1)	42	74	32
Turbidity	NTU (1)	1.2	34	8
Total Alkalinity	mg/l as CaCO3 (1)	47	78	61
Hardness	mg/l as CaCO3 (0.02)	42	39	
Total Suspended Solids	mg/l (0.05)	2.4	57	
Ammonia	mg/l as N (0.03)	0.017	60	
Nitrate+Nitrite	mg/l as N (0.01)	0.016	45	
Total Kjeldahl Nitrogen	mg/l as N (0.06)	0.75	30	
Orthophosphorus	mg/l as P (0.01)	0.005	56	
Chloride	mg/l (0.05)	14	30	
Sulfate	mg/l (0.05)	1	6	
Sodium	mg/l (0.06)	25.7	>95	
Potassium	mg/l (0.07)	6.2	74	
Calcium	mg/l (0.04)	14.3	57	
Magnesium	mg/l (0.006)	1.3	12	
Iron	ug/l (0.03)	38	50	

Henderson Lake is in the Inverness Pool of the Lake Tsala Apopka chain. Based upon the average FTSI of 36, water quality is considered good. Henderson Lake can be characterized as a colored, soft water, mesotrophic lake. The chemical type of water (predominant ionic composition) is calcium bicarbonate. Also of note: The measured pH was high; Hydrilla was observed in the lake; Cattails dominate more than 30% of the lake shoreline.

Plots and Trends: The plot of lake elevation is for the Inverness Pool of Lake Tsala Apopka. No trend in lake levels is evident. Lake Henderson received treated effluent from the City of Inverness until the mid-1980s. This is reflected in historical total phosphorus concentrations, which were higher through the 1970s and the mid-1980s, and declined thereafter. Florida TSI mirror the total P plot, largely because the FTSI are calculated from total P and other measures of productivity and potential productivity. Also shown is a diagram of the relative ionic composition of the lake water.

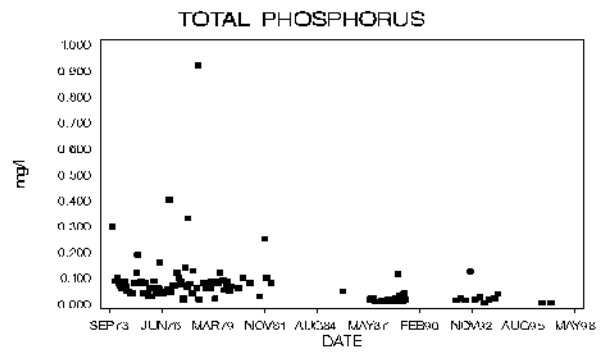
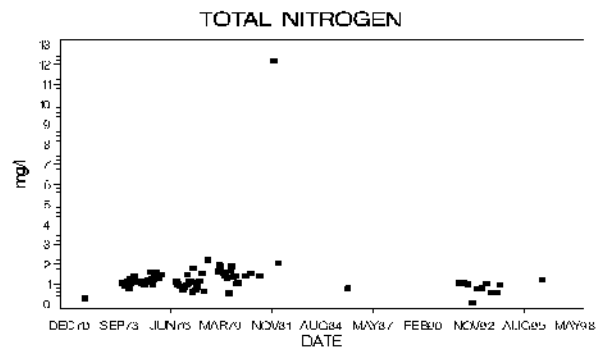
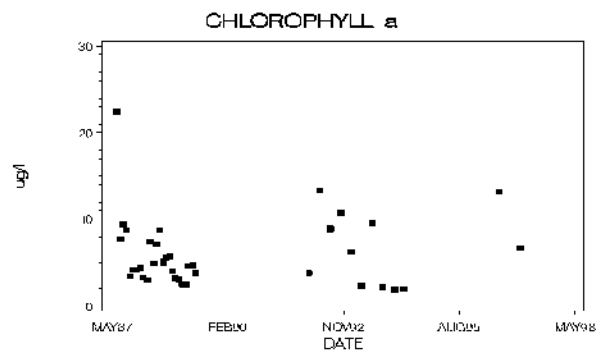
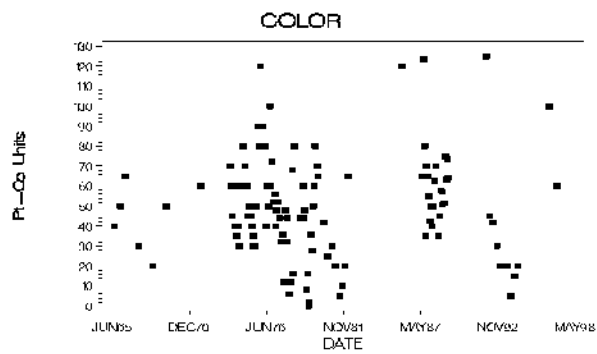
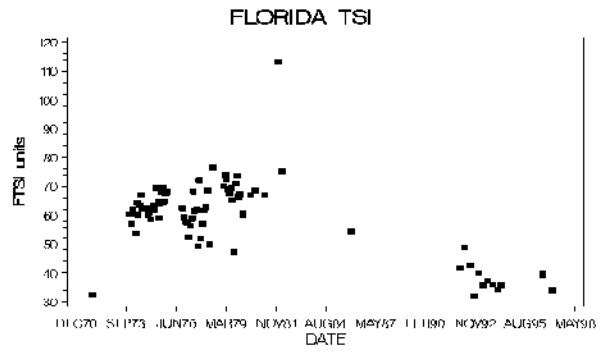
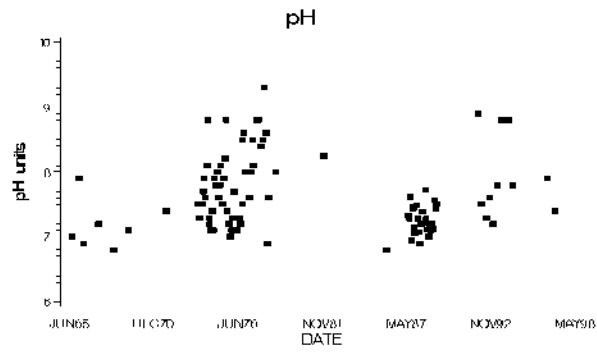
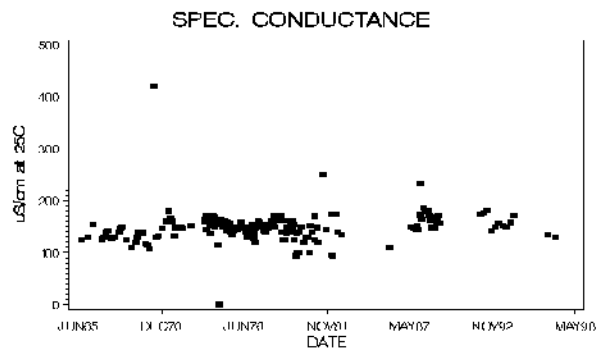
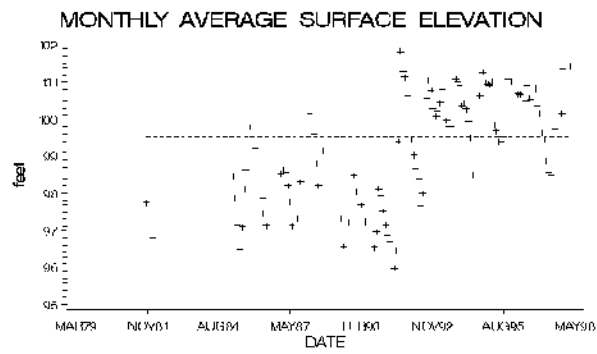

Henederson Lake, Citrus County

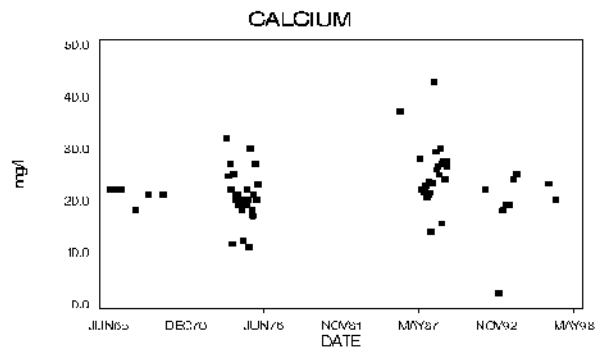
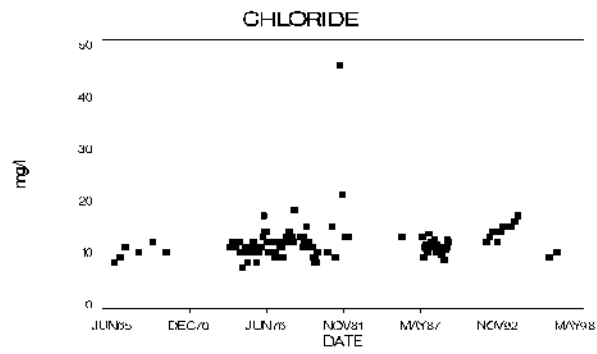
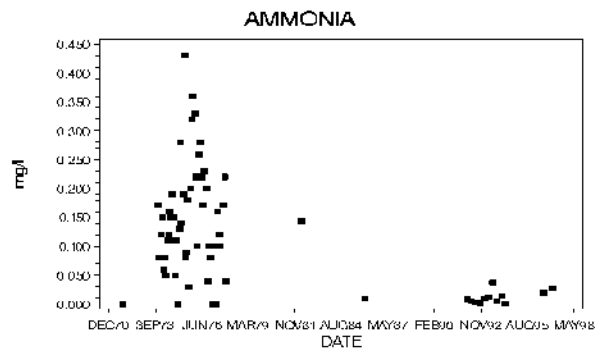
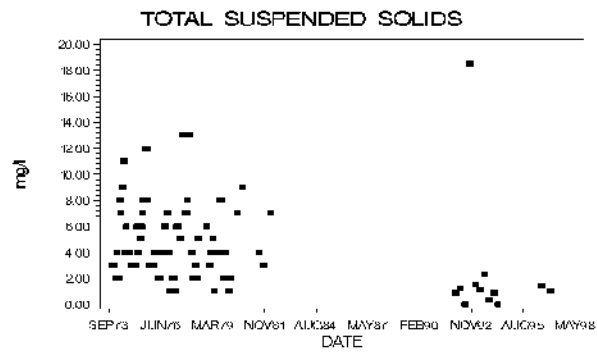
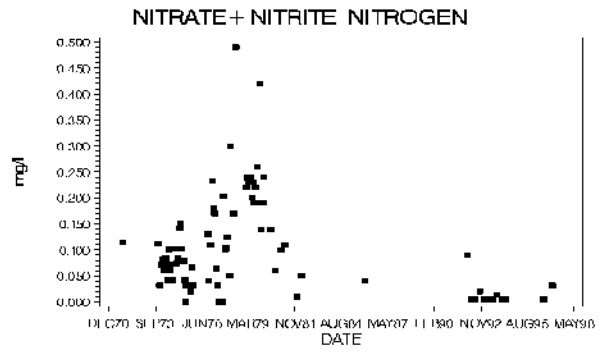
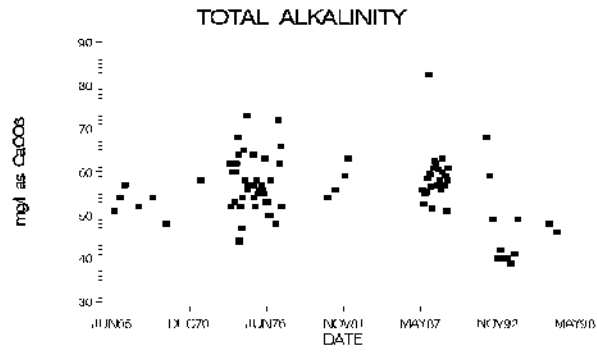
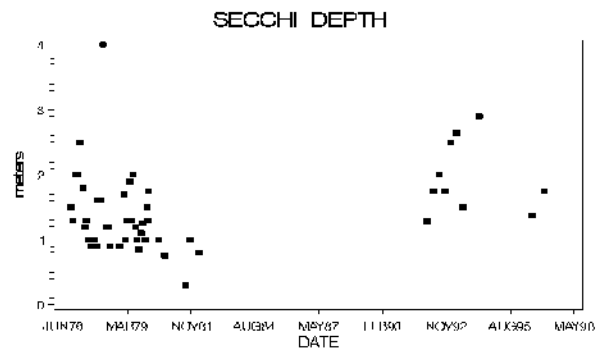
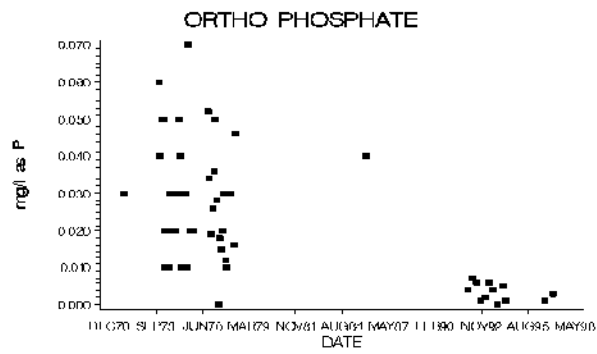

Henederson Lake, Citrus County

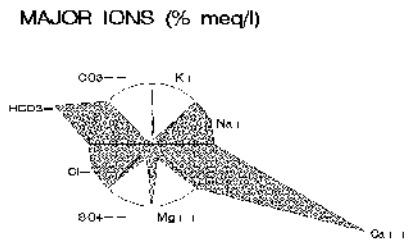
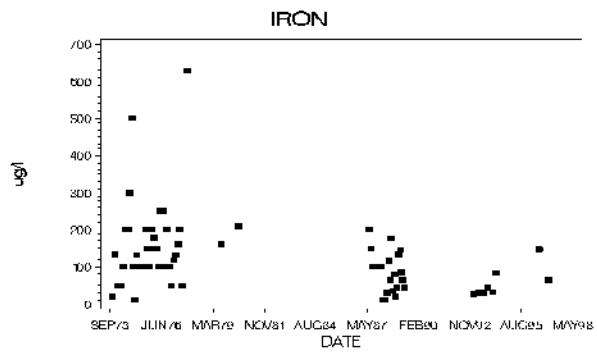
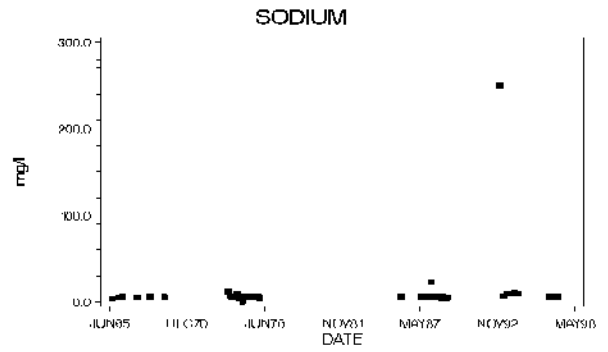
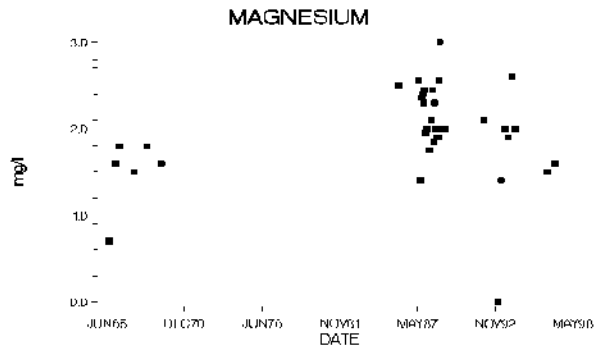
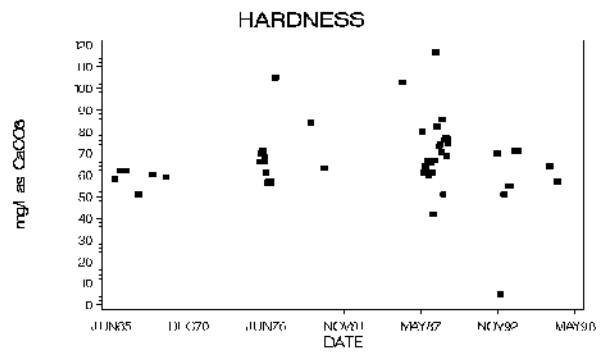
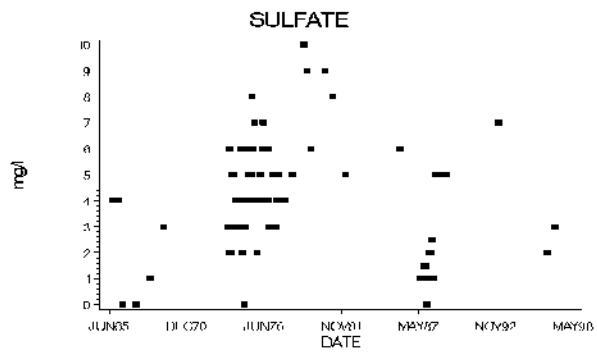

Henederson Lake, Citrus County

Hernando Lake

Citrus County

USGS Quadrangle: Stokes Ferry Major Land Use/Land Cover (1990)
 Section/Township/Range: 24-18S-19E within 500 meters of the lakeshore:
 Approx. Lake Center, Lat/Long: 285425/822203 - medium density residential (36%)
 Surface Area: 317 acres - cropland and pastureland (14%)
 Approx. Lake Elevation: 39 feet - commercial and services (10%)
 Average Depth: 6.9 feet
 Observed Maximum Depth: 21 feet
 (reference elevation not given)
 Lake Type: inflow and outflow (type 3)
 Major Basin: Withlacoochee River
 Minor Basin: Tsala Apopka Outlet
 Lake Region: Tsala Apopka
 Public Access: yes

Total Number of Samples Collected: 12 Most Recent Sample Collected: January 1997

Parameter	Units (Detection Limit)	Average Value	District Percentile	Florida Percentile
Chlorophyll a	ug/l (1)	2.7	21	11
Total Phosphorus	mg/l as P (0.01)	0.013	46	7
Total Nitrogen	mg/l as N (0.06)	0.61	9	16
Transparency (Secchi depth)	meters	2.33	72	90
Florida Trophic State Index		29	23	<5
Specific Conductance	S/cm at 25C (1)	117	18	30
pH	standard units (0.1)	8.3	87	78
Color	PtCo units (1)	13	41	12
Turbidity	NTU (1)	0.5	28	<5
Total Alkalinity	mg/l as CaCO3 (1)	32	62	51
Hardness	mg/l as CaCO3 (0.02)	32	25	
Total Suspended Solids	mg/l (0.05)	0.5	11	
Ammonia	mg/l as N (0.03)	0.018	60	
Nitrate+Nitrite	mg/l as N (0.01)	0.009	33	
Total Kjeldahl Nitrogen	mg/l as N (0.06)	0.60	15	
Orthophosphorus	mg/l as P (0.01)	0.005	56	
Chloride	mg/l (0.05)	11	19	
Sulfate	mg/l (0.05)	1	6	
Sodium	mg/l (0.06)	4.2	10	
Potassium	mg/l (0.07)	0.1	<5	
Calcium	mg/l (0.04)	11.4	45	
Magnesium	mg/l (0.006)	1.0	6	
Iron	ug/l (0.03)	14	9	

Hernando Lake is in the Hernando Pool of the Lake Tsala Apopka chain. Based upon the average FTSI of 29, water quality is considered good. Hernando Lake can be characterized as a clear to moderately colored (10<color<20 color units), soft water, oligo-mesotrophic lake, with low concentrations of total nitrogen. The chemical type of water (predominant ionic composition) is calcium bicarbonate. Also of note: the measured pH was high.

Plots and Trends: The plot of lake elevation is for the Hernando Pool of Lake Tsala Apopka. No trend in elevation is evident. Most measures of water chemistry demonstrate no trend for the period of record. The values of pH measured during the 1980s and 1990s seem to be greater than those measured between 1965 and 1970, but the data are sporadic for the period of record and it can not be determined if the change represents a trend. Also shown is a diagram of the relative ionic composition of the lake water.

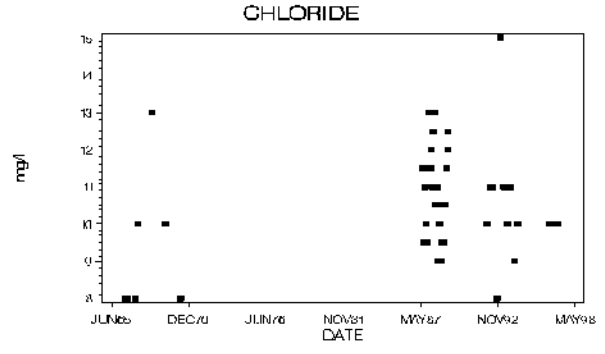
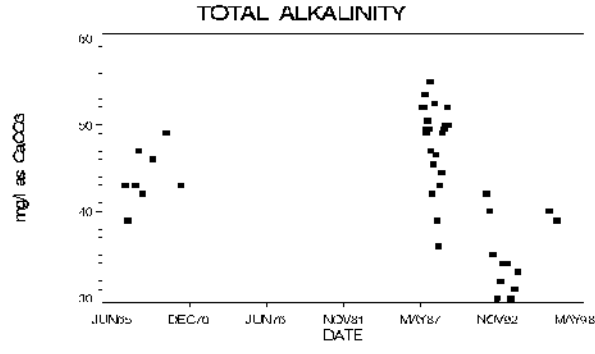
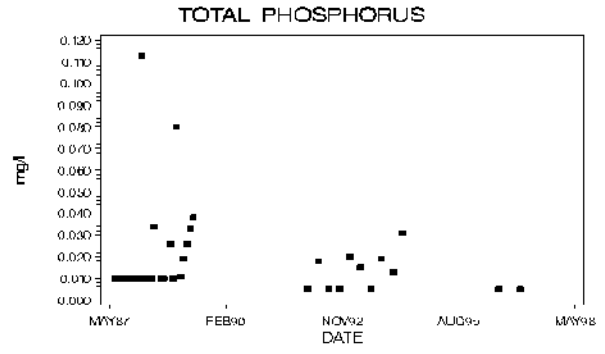
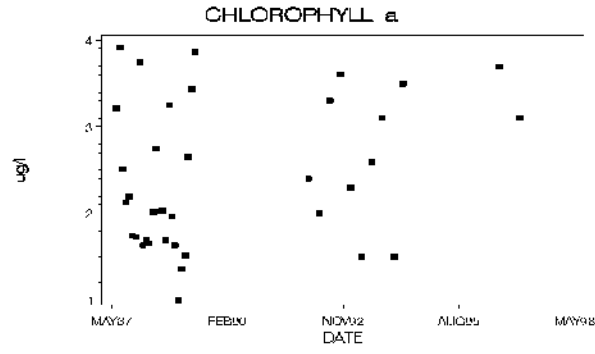
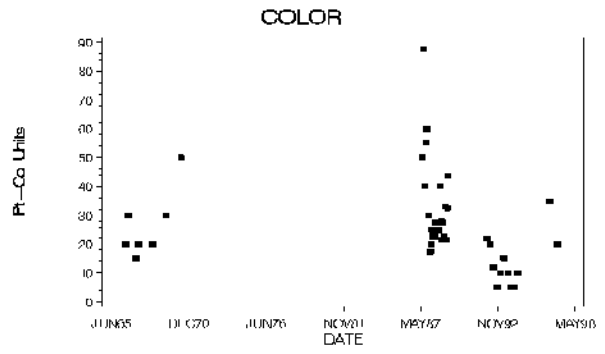
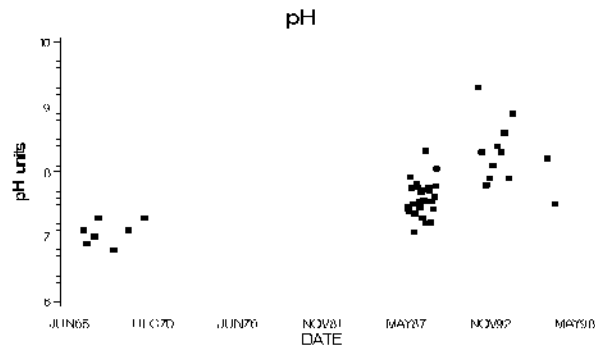
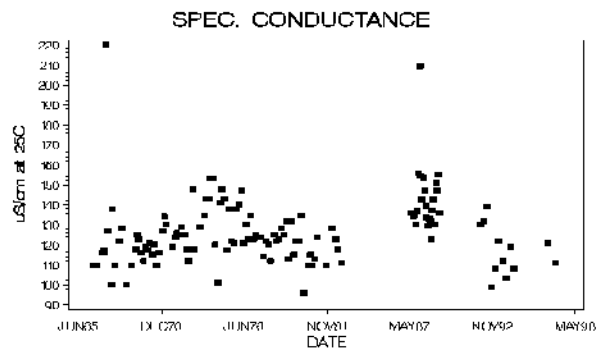
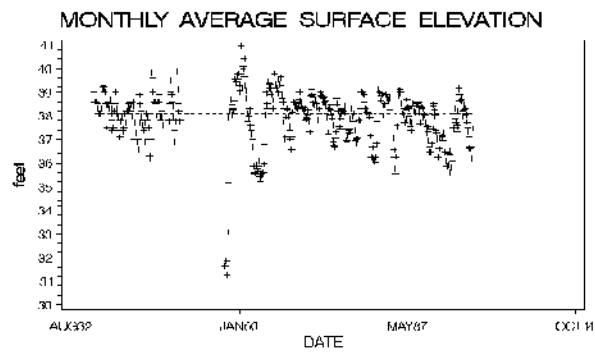

Hernando Lake, Citrus County

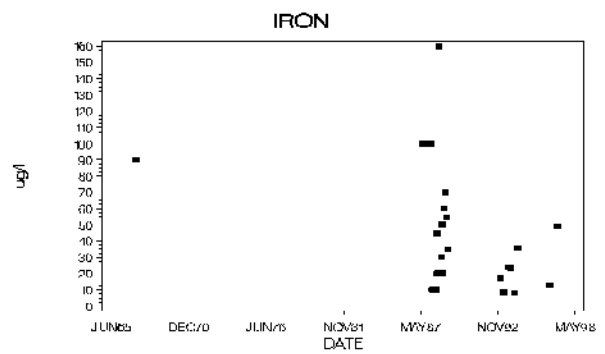
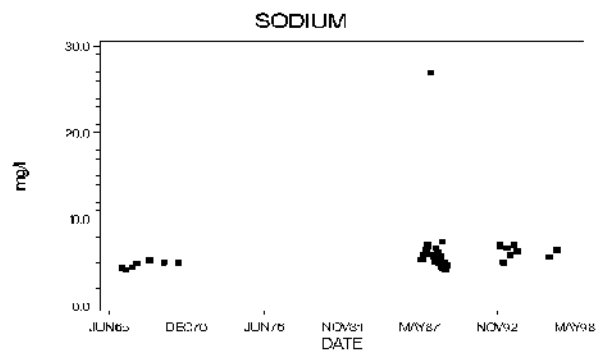
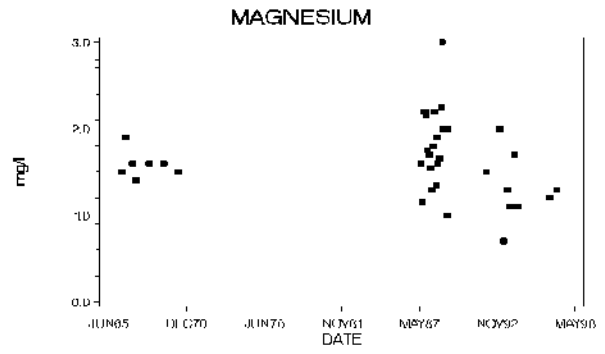
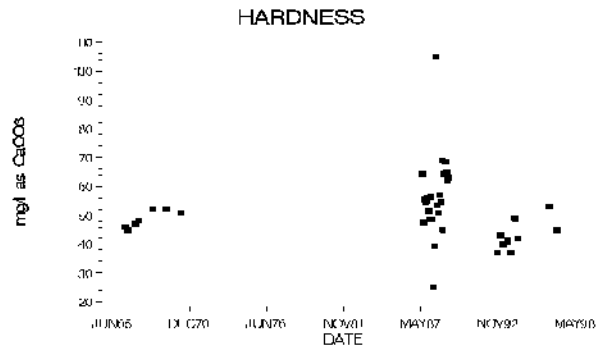
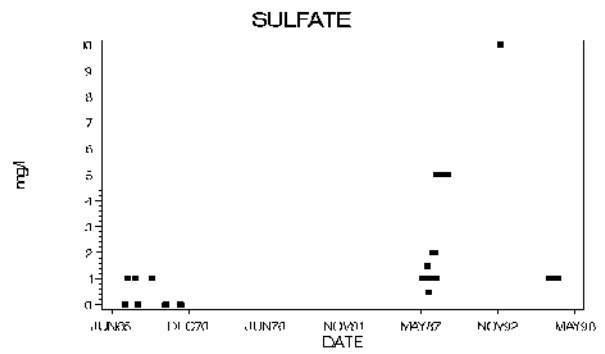
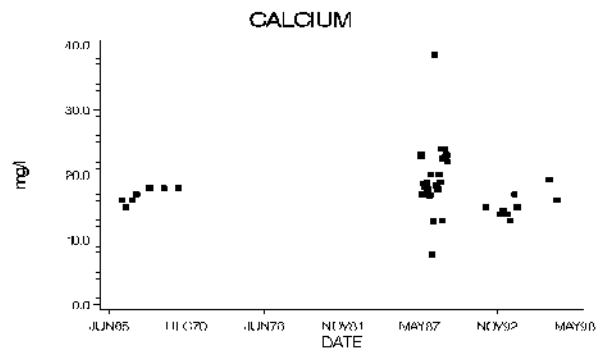

MAJOR IONS (% meq/l)

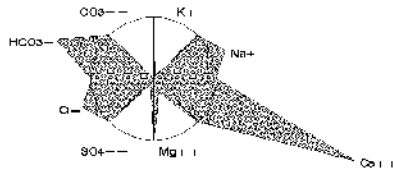

Hernando Lake, Citrus County

Hog Pond (Lake Nina)

Citrus County

USGS Quadrangle:	Inverness	Major Land Use/Land Cover (1990)
Section/Township/Range:	2-19S-19E	within 500 meters of the lakeshore:
Approx. Lake Center, Lat/Long:	285216/822230	- medium density residential (39%)
Surface Area:	38 acres	- low density residential (37%)
Approx. Lake Elevation:	35 feet	- cropland and pastureland (11%)
Lake Type:	isolated (type 4)	
Major Basin:	Withlacoochee River	
Minor Basin:	Tsala Apopka Outlet	
Lake Region:	Southern Brooksville Ridge	

Total Number of Samples Collected: 2 Most Recent Sample Collected: January 1997

Parameter	Units (Detection Limit)	Average Value	District Percentile	Florida Percentile
Chlorophyll a	ug/l (1)	2.9	23	12
Total Phosphorus	mg/l as P (0.01)	0.019	63	10
Total Nitrogen	mg/l as N (0.06)	0.59	8	15
Transparency (Secchi depth)	meters		-	-
Florida Trophic State Index		24	12	<5
Specific Conductance	S/cm at 25C (1)	125	22	33
pH	standard units (0.1)	7.3	50	45
Color	PtCo units (1)	15	46	13
Turbidity	NTU (1)	0.8	28	<5
Total Alkalinity	mg/l as CaCO3 (1)	55	83	65
Hardness	mg/l as CaCO3 (0.02)	58	60	
Total Suspended Solids	mg/l (0.05)	0.7	18	
Ammonia	mg/l as N (0.03)	0.015	60	
Nitrate+Nitrite	mg/l as N (0.01)	0.005	33	
Total Kjeldahl Nitrogen	mg/l as N (0.06)	0.59	14	
Orthophosphorus	mg/l as P (0.01)	0.012	68	
Chloride	mg/l (0.05)	5	<5	
Sulfate	mg/l (0.05)	0	<5	
Sodium	mg/l (0.06)	2.5	<5	
Potassium	mg/l (0.07)	0.0	<5	
Calcium	mg/l (0.04)	22.0	81	
Magnesium	mg/l (0.006)	0.8	<5	
Iron	ug/l (0.03)	120	85	

Based upon the average FTSI of 24, water quality is considered good. Hog Pond (Lake Nina) can be characterized as a clear to moderately colored (10<color<20 color units), soft water, mesotrophic lake, with very low concentrations of total nitrogen. The chemical type of water (predominant ionic composition) is calcium bicarbonate.

Plots and Trends: No or insufficient data available for plotting or trend detection. Shown is a diagram of the relative ionic composition of the lake water.

MAJOR IONS (% meq/l)

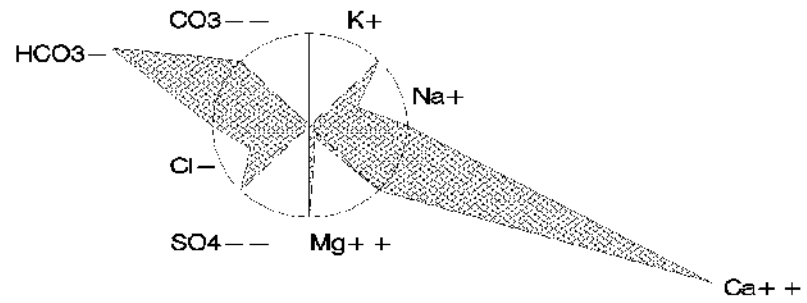

Hog Pond (Lake Nina), Citrus County

Holden Lake

Citrus County

USGS Quadrangle: Inverness Major Land Use/Land Cover (1990)
 Section/Township/Range: 32-19S-20E within 500 meters of the lakeshore:
 Approx. Lake Center, Lat/Long: 284741/821935 - medium density residential (54%)
 Surface Area: 39 acres - cropland and pastureland (14%)
 Approx. Lake Elevation: 32 feet - low density residential (12%)
 Lake Type: isolated (type 4)
 Major Basin: Withlacoochee River
 Minor Basin: Tsala Apopka Outlet
 Lake Region: Southern Brooksville Ridge
 Public Access: yes

Total Number of Samples Collected: 2 Most Recent Sample Collected: January 1997

Parameter	Units (Detection Limit)	Average Value	District Percentile	Florida Percentile
Chlorophyll a	ug/l (1)	32.4	87	68
Total Phosphorus	mg/l as P (0.01)	0.021	66	11
Total Nitrogen	mg/l as N (0.06)	1.35	63	48
Transparency (Secchi depth)	meters	0.50	9	20
Florida Trophic State Index		39	51	14
Specific Conductance	S/cm at 25C (1)	382	94	75
pH	standard units (0.1)	6.2	8	10
Color	PtCo units (1)	118	91	83
Turbidity	NTU (1)	3.7	68	39
Total Alkalinity	mg/l as CaCO3 (1)	19	41	38
Hardness	mg/l as CaCO3 (0.02)	26	16	
Total Suspended Solids	mg/l (0.05)	4.2	74	
Ammonia	mg/l as N (0.03)	0.033	64	
Nitrate+Nitrite	mg/l as N (0.01)	0.005	33	
Total Kjeldahl Nitrogen	mg/l as N (0.06)	1.35	71	
Orthophosphorus	mg/l as P (0.01)	0.012	68	
Chloride	mg/l (0.05)	4	<5	
Sulfate	mg/l (0.05)	0	<5	
Sodium	mg/l (0.06)	3.8	8	
Potassium	mg/l (0.07)	0.1	<5	
Calcium	mg/l (0.04)	9.6	38	
Magnesium	mg/l (0.006)	0.5	<5	
Iron	ug/l (0.03)	308	>95	

Based upon the average FTSI of 39, water quality is considered good. Holden Lake can be characterized as a highly colored, soft water, hypereutrophic lake. The chemical type of water (predominant ionic composition) is calcium bicarbonate.

Plots and Trends: No trend in lake surface elevation is evident over the short period of record. Also shown is a diagram of the relative ionic composition of the lake water.

MONTHLY AVERAGE SURFACE ELEVATION

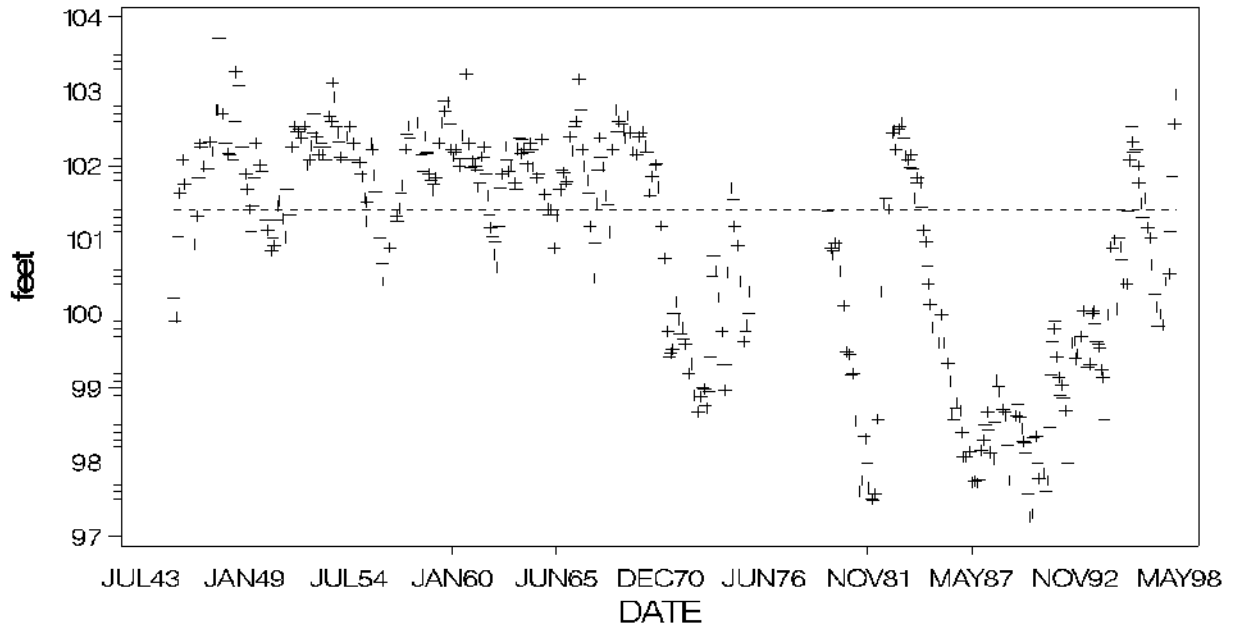

MAJOR IONS (% meq/l)

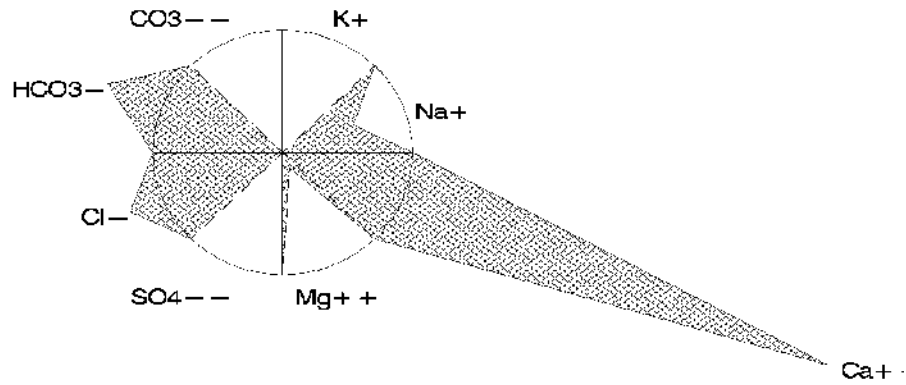

+

Little Lake (Consuella) Citrus County

USGS Quadrangle:	Nobleton	Major Land Use/Land Cover (1990)
Section/Township/Range:	15-20S-20E	within 500 meters of the lakeshore:
Approx. Lake Center, Lat/Long:	284444/821729	- low density residential (51%)
Surface Area:	57 acres	- medium density residential (13%)
Approx. Lake Elevation:	42 feet	- other open lands - rural (9%)
Lake Type:	outflow (type 2)	
Major Basin:	Withlacoochee River	
Minor Basin:	Tsala Apopka Outlet	
Lake Region:	Tsala Apopka	

Total Number of Samples Collected: 2 Most Recent Sample Collected: January 1997

Parameter	Units (Detection Limit)	Average Value	District Percentile	Florida Percentile
Chlorophyll a	ug/l (1)	4.8	43	19
Total Phosphorus	mg/l as P (0.01)	0.044	85	37
Total Nitrogen	mg/l as N (0.06)	1.04	43	35
Transparency (Secchi depth)	meters	1.27	43	71
Florida Trophic State Index		27	20	<5
Specific Conductance	S/cm at 25C (1)	86	10	18
pH	standard units (0.1)	7.1	38	35
Color	PtCo units (1)	93	88	74
Turbidity	NTU (1)	2.0	51	20
Total Alkalinity	mg/l as CaCO3 (1)	28	55	47
Hardness	mg/l as CaCO3 (0.02)	32	25	
Total Suspended Solids	mg/l (0.05)	1.6	42	
Ammonia	mg/l as N (0.03)	0.052	76	
Nitrate+Nitrite	mg/l as N (0.01)	0.033	60	
Total Kjeldahl Nitrogen	mg/l as N (0.06)	1.01	48	
Orthophosphorus	mg/l as P (0.01)	0.012	68	
Chloride	mg/l (0.05)	7	7	
Sulfate	mg/l (0.05)	2	10	
Sodium	mg/l (0.06)	6.3	25	
Potassium	mg/l (0.07)	0.6	13	
Calcium	mg/l (0.04)	11.0	43	
Magnesium	mg/l (0.006)	1.3	12	
Iron	ug/l (0.03)	82	75	

Based upon the average FTSI of 27, water quality is considered fair. Little Lake (Consuella) can be characterized as a highly colored, soft water, eutrophic lake, with high concentrations of total phosphorus. The chemical type of water (predominant ionic composition) is calcium bicarbonate.

Plots and Trends: Lake levels have been relatively stable over the period of record. Also shown is a diagram of the relative ionic composition of the lake water.

MONTHLY AVERAGE SURFACE ELEVATION

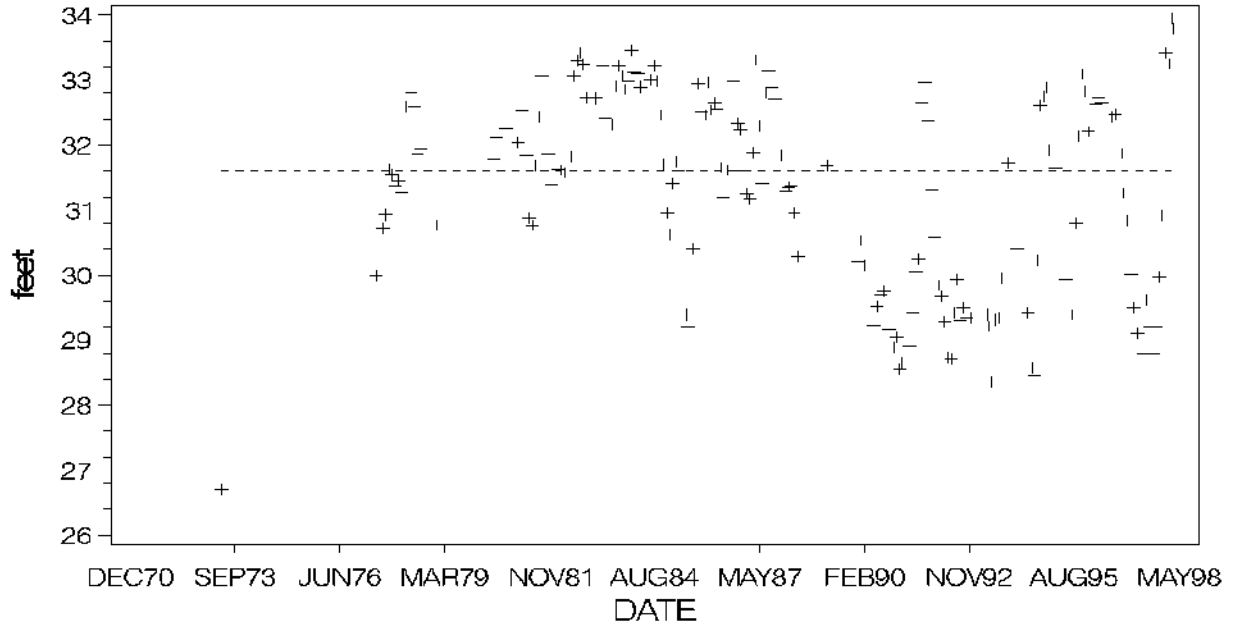

MAJOR IONS (% meq/l)

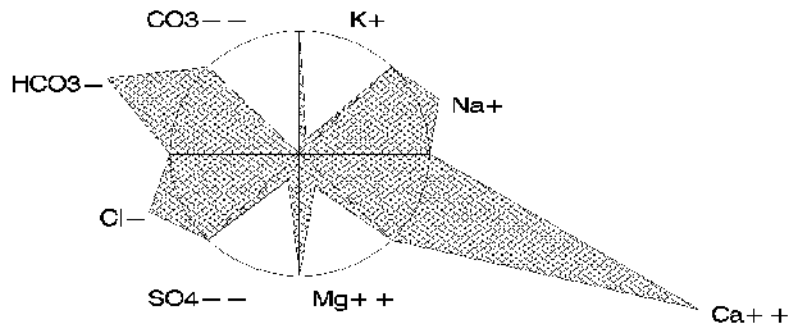

Little Lake (Consuella), Citrus County

Little Henderson Lake

Citrus County

USGS Quadrangle: Inverness Major Land Use/Land Cover (1990)
 Section/Township/Range: 8-19S-20E within 500 meters of the lakeshore:
 Approx. Lake Center, Lat/Long: 285053/821951 - medium density residential (31%)
 Surface Area: 236 acres - high density residential (10%)
 Approx. Lake Elevation: 41 feet - longleaf pine - xeric pine (10%)
 Average Depth: 11.2 feet
 Observed Maximum Depth: 20 feet
 (reference elevation 41 feet)
 Lake Type: inflow and outflow (type 3)
 Major Basin: Withlacoochee River
 Minor Basin: Tsala Apopka Outlet
 Lake Region: Tsala Apopka
 Public Access: yes

Total Number of Samples Collected: 2 Most Recent Sample Collected: January 1997

Parameter	Units (Detection Limit)	Average Value	District Percentile	Florida Percentile
Chlorophyll a	ug/l (1)	7.6	55	32
Total Phosphorus	mg/l as P (0.01)	0.005	31	<5
Total Nitrogen	mg/l as N (0.06)	0.64	14	17
Transparency (Secchi depth)	meters	1.53	51	77
Florida Trophic State Index		34	38	9
Specific Conductance	S/cm at 25C (1)	130	25	35
pH	standard units (0.1)	7.7	69	60
Color	PtCo units (1)	93	88	74
Turbidity	NTU (1)	0.8	28	<5
Total Alkalinity	mg/l as CaCO3 (1)	46	77	60
Hardness	mg/l as CaCO3 (0.02)	57	59	
Total Suspended Solids	mg/l (0.05)	0.7	18	
Ammonia	mg/l as N (0.03)	0.015	60	
Nitrate+Nitrite	mg/l as N (0.01)	0.031	59	
Total Kjeldahl Nitrogen	mg/l as N (0.06)	0.62	17	
Orthophosphorus	mg/l as P (0.01)	0.005	56	
Chloride	mg/l (0.05)	10	15	
Sulfate	mg/l (0.05)	3	14	
Sodium	mg/l (0.06)	5.7	19	
Potassium	mg/l (0.07)	1.2	21	
Calcium	mg/l (0.04)	20.7	78	
Magnesium	mg/l (0.006)	1.5	16	
Iron	ug/l (0.03)	66	70	

Little Henderson Lake is in the Inverness Pool of the Lake Tsala Apopka chain. Based upon the average FTSI of 34, water quality is considered good. Little Henderson Lake can be characterized as a highly colored, soft water, meso-eutrophic lake, with low concentrations of total phosphorus. The chemical type of water (predominant ionic composition) is calcium bicarbonate.

Plots and Trends: The plot of lake elevation is for the Inverness Pool of Lake Tsala Apopka. No trend in elevation is evident. No trends are apparent in the plots of the available water chemistry data. Also shown is a diagram of the relative ionic composition of the lake water.

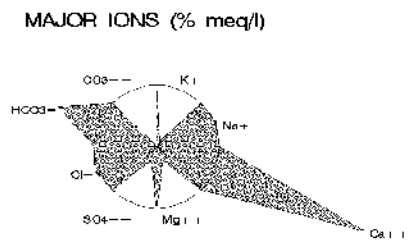
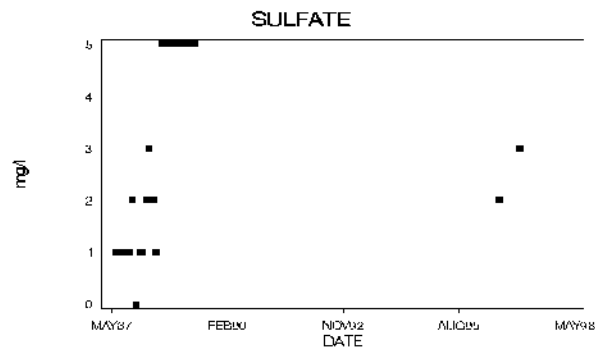
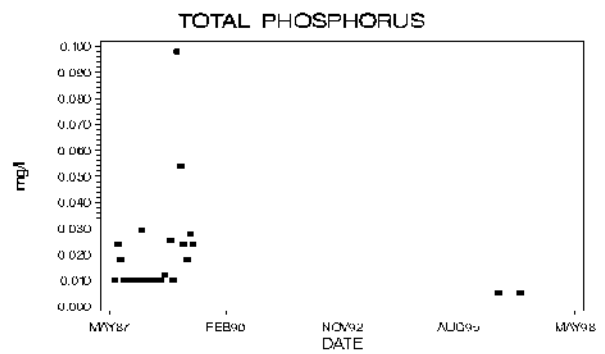
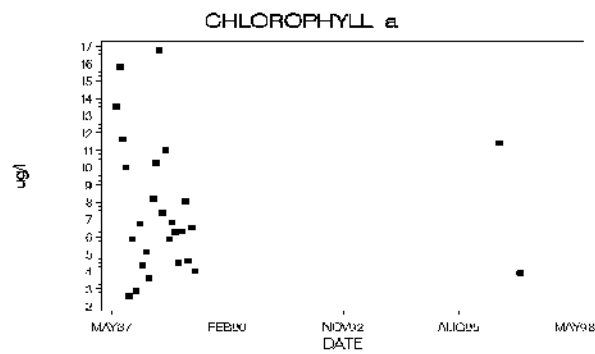
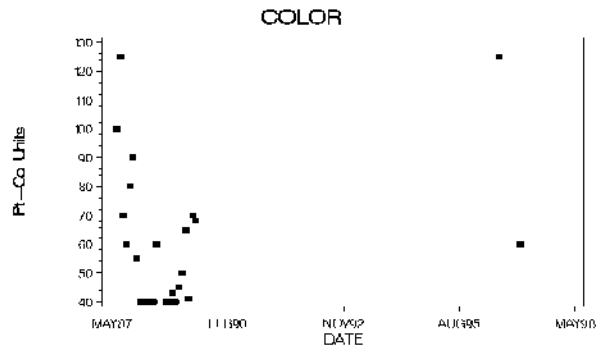
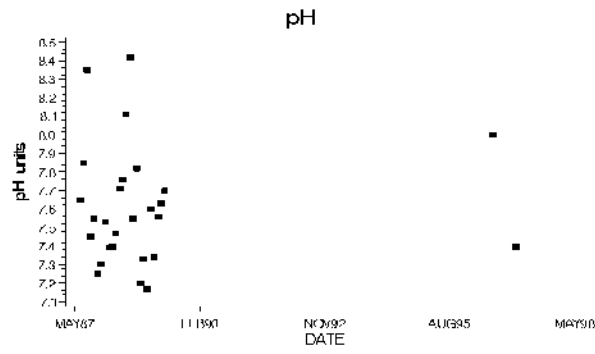
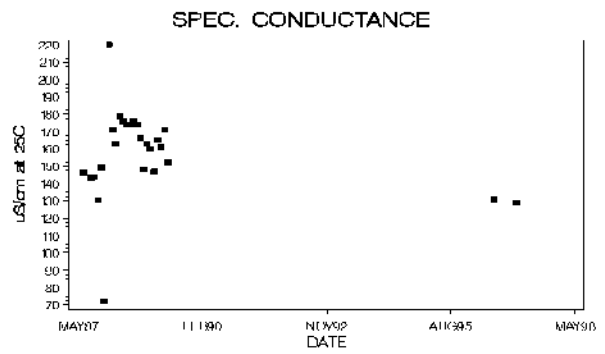
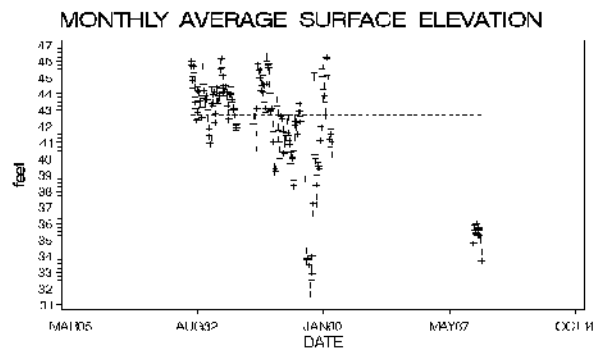

Little Henderson Lake, Citrus County

Magnolia Lake

Citrus County

USGS Quadrangle: Inverness Major Land Use/Land Cover (1990)
 Section/Township/Range: 3-20S-20E within 500 meters of the lakeshore:
 Approx. Lake Center, Lat/Long: 284643/821804 - low density residential (28%)
 Surface Area: 64 acres - high density residential (16%)
 Approx. Lake Elevation: 31 feet - longleaf pine - xeric pine (12%)
 Lake Type: isolated (type 4)
 Major Basin: Withlacoochee River
 Minor Basin: Tsala Apopka Outlet
 Lake Region: Tsala Apopka

Total Number of Samples Collected: 2 Most Recent Sample Collected: January 1997

Parameter	Units (Detection Limit)	Average Value	District Percentile	Florida Percentile
Chlorophyll a	ug/l (1)	0.8	<5	<5
Total Phosphorus	mg/l as P (0.01)	0.014	50	7
Total Nitrogen	mg/l as N (0.06)	0.71	18	21
Transparency (Secchi depth)	meters		-	-
Florida Trophic State Index		12	<5	<5
Specific Conductance	S/cm at 25C (1)	320	90	71
pH	standard units (0.1)	7.2	43	40
Color	PtCo units (1)	18	51	15
Turbidity	NTU (1)	0.5	28	<5
Total Alkalinity	mg/l as CaCO3 (1)	151	>95	>95
Hardness	mg/l as CaCO3 (0.02)	148	>95	
Total Suspended Solids	mg/l (0.05)	0.1	<5	
Ammonia	mg/l as N (0.03)	0.015	60	
Nitrate+Nitrite	mg/l as N (0.01)	0.005	33	
Total Kjeldahl Nitrogen	mg/l as N (0.06)	0.71	24	
Orthophosphorus	mg/l as P (0.01)	0.012	68	
Chloride	mg/l (0.05)	9	12	
Sulfate	mg/l (0.05)	0	<5	
Sodium	mg/l (0.06)	7.2	35	
Potassium	mg/l (0.07)	0.1	<5	
Calcium	mg/l (0.04)	54.5	>95	
Magnesium	mg/l (0.006)	2.8	41	
Iron	ug/l (0.03)	76	74	

Based upon the average FTSI of 12, water quality is considered good. Magnolia Lake can be characterized as a clear to moderately colored (10<color<20 color units), hard water, oligotrophic lake, with low concentrations of total nitrogen. The chemical type of water (predominant ionic composition) is calcium bicarbonate.

Also of note:

- Hydrilla was observed in the lake.

Plots and Trends: Period of record data show that lake surface elevation was high in the early 1980s, and then declined for several years to surface elevations that have since fluctuated around 26 feet. Also shown is a diagram of the relative ionic composition of the lake water.

MONTHLY AVERAGE SURFACE ELEVATION

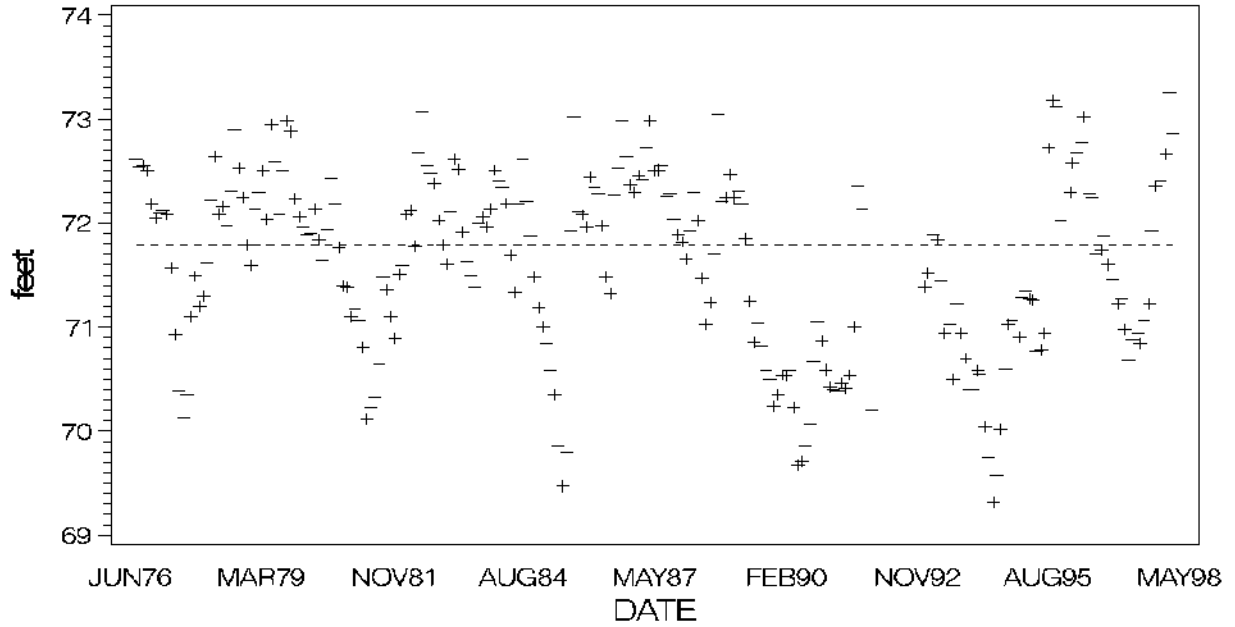

MAJOR IONS (% meq/l)

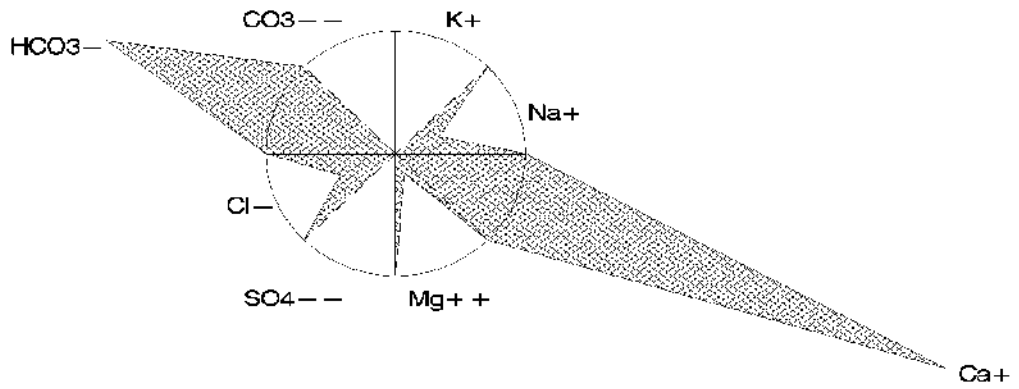

Rush Lake

Citrus County

USGS Quadrangle: Dunnellon Major Land Use/Land Cover (1990)
 Section/Township/Range: 3-17S-18E within 500 meters of the lakeshore:
 Approx. Lake Center, Lat/Long: 290207/822824 - hardwood - conifer mixed (25%)
 Surface Area: 52 acres - open land (21%)
 Approx. Lake Elevation: 36 feet - other open lands - rural (19%)
 Lake Type: outflow (type 2)
 Major Basin: Withlacoochee River
 Minor Basin: Withlacoochee River
 Lake Region: Southern Brooksville Ridge

Total Number of Samples Collected: 2 Most Recent Sample Collected: January 1995

Parameter	Units (Detection Limit)	Average Value	District Percentile	Florida Percentile
Chlorophyll a	ug/l (1)	3.1	26	13
Total Phosphorus	mg/l as P (0.01)	0.005	31	<5
Total Nitrogen	mg/l as N (0.06)	2.59	92	89
Transparency (Secchi depth)	meters	1.50	49	76
Florida Trophic State Index		29	26	<5
Specific Conductance	S/cm at 25C (1)	41	<5	<5
pH	standard units (0.1)	6.3	10	13
Color	PtCo units (1)	18	51	15
Turbidity	NTU (1)	2.1	53	21
Total Alkalinity	mg/l as CaCO3 (1)	31	60	50
Hardness	mg/l as CaCO3 (0.02)	7	<5	
Total Suspended Solids	mg/l (0.05)	1.7	44	
Ammonia	mg/l as N (0.03)	0.036	66	
Nitrate+Nitrite	mg/l as N (0.01)	0.005	33	
Total Kjeldahl Nitrogen	mg/l as N (0.06)	2.58	>95	
Orthophosphorus	mg/l as P (0.01)	0.005	56	
Chloride	mg/l (0.05)	7	7	
Sulfate	mg/l (0.05)	3	14	
Sodium	mg/l (0.06)	3.9	8	
Potassium	mg/l (0.07)	0.1	<5	
Calcium	mg/l (0.04)	1.7	<5	
Magnesium	mg/l (0.006)	0.7	<5	
Iron	ug/l (0.03)	37	49	

Based upon the average FTSI of 29, water quality is considered good. Rush Lake can be characterized as a clear to moderately colored (10<color<20 color units), soft water, oligo-mesotrophic lake, with low concentrations of total phosphorus and high concentrations of total nitrogen. The chemical type of water (predominant ionic composition) is sodium bicarbonate (1 sample) or sodium chloride (1 sample).

Plots and Trends: No or insufficient data available for plotting or trend detection. Shown is a diagram of the relative ionic composition of the lake water.

MAJOR IONS (% meq/l)

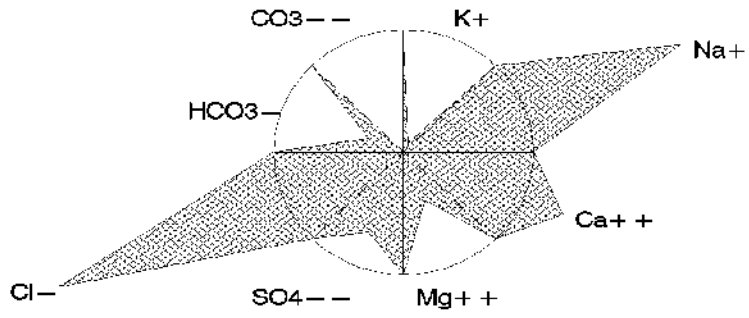

Rush Lake, Citrus County

Spivey Lake

Citrus County

USGS Quadrangle: Inverness Major Land Use/Land Cover (1990)
 Section/Township/Range: 15-19S-20E within 500 meters of the lakeshore:
 Approx. Lake Center, Lat/Long: 284951/821757 - medium density residential (35%)
 Surface Area: 155 acres - cropland and pastureland (12%)
 Approx. Lake Elevation: 93 feet - upland coniferous forests (9%)
 Average Depth: 8.5 feet
 (reference elevation 92.94 feet)
 Lake Type: inflow and outflow (type 3)
 Major Basin: Withlacoochee River
 Minor Basin: Tsala Apopka Outlet
 Lake Region: Tsala Apopka
 Public Access: yes

Total Number of Samples Collected: 2 Most Recent Sample Collected: January 1997

Parameter	Units (Detection Limit)	Average Value	District Percentile	Florida Percentile
Chlorophyll a	ug/l (1)	9.3	61	36
Total Phosphorus	mg/l as P (0.01)	0.005	31	<5
Total Nitrogen	mg/l as N (0.06)	1.37	64	49
Transparency (Secchi depth)	meters	1.29	45	72
Florida Trophic State Index		32	35	7
Specific Conductance	S/cm at 25C (1)	118	19	30
pH	standard units (0.1)	7.4	57	50
Color	PtCo units (1)	105	90	79
Turbidity	NTU (1)	1.3	36	10
Total Alkalinity	mg/l as CaCO3 (1)	39	70	55
Hardness	mg/l as CaCO3 (0.02)	54	55	
Total Suspended Solids	mg/l (0.05)	0.6	15	
Ammonia	mg/l as N (0.03)	0.015	60	
Nitrate+Nitrite	mg/l as N (0.01)	0.009	33	
Total Kjeldahl Nitrogen	mg/l as N (0.06)	1.37	72	
Orthophosphorus	mg/l as P (0.01)	0.005	56	
Chloride	mg/l (0.05)	10	15	
Sulfate	mg/l (0.05)	1	6	
Sodium	mg/l (0.06)	5.3	15	
Potassium	mg/l (0.07)	0.6	13	
Calcium	mg/l (0.04)	19.2	73	
Magnesium	mg/l (0.006)	1.4	15	
Iron	ug/l (0.03)	96	80	

Spivey Lake is in the Inverness Pool of the Lake Tsala Apopka chain. Based upon the average FTSI of 32, water quality is considered good. Spivey Lake can be characterized as a highly colored, soft water, mesotrophic lake, with low concentrations of total phosphorus. The chemical type of water (predominant ionic composition) is calcium bicarbonate.

Also of note:

- Cattails dominate more than 30% of the lake shoreline.

Plots and Trends: The plot of lake elevation is for the Inverness Pool of Lake Tsala Apopka. No trend in elevation is evident. Also shown is a diagram of the relative ionic composition of the lake water.

MONTHLY AVERAGE SURFACE ELEVATION

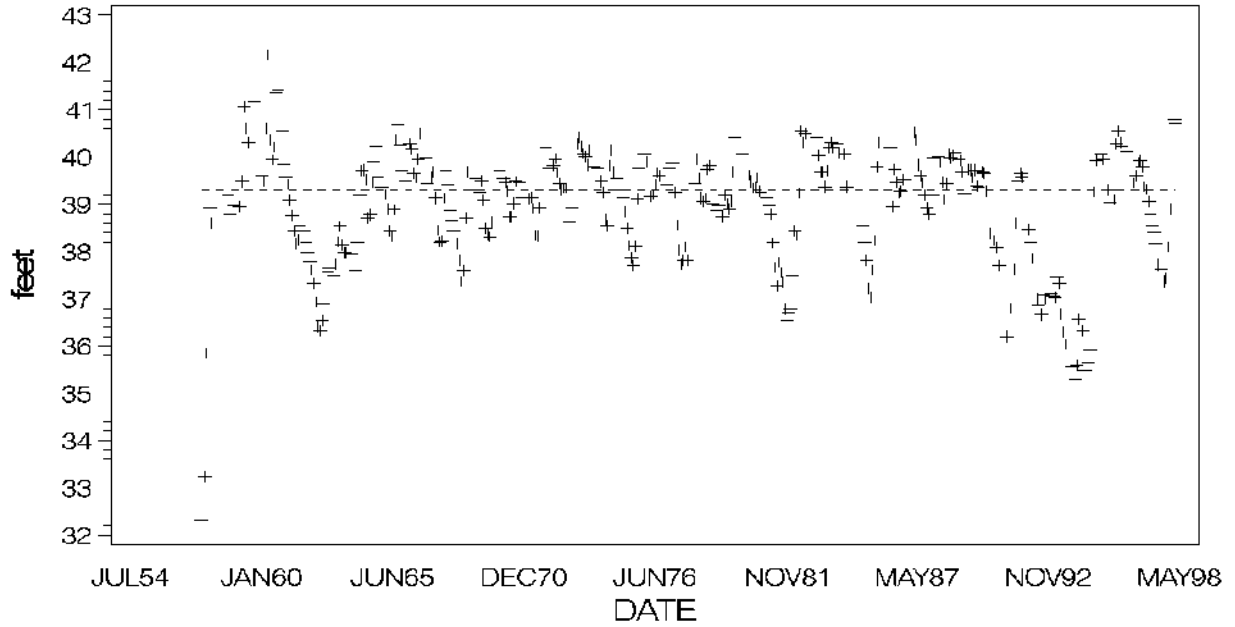

MAJOR IONS (% meq/l)

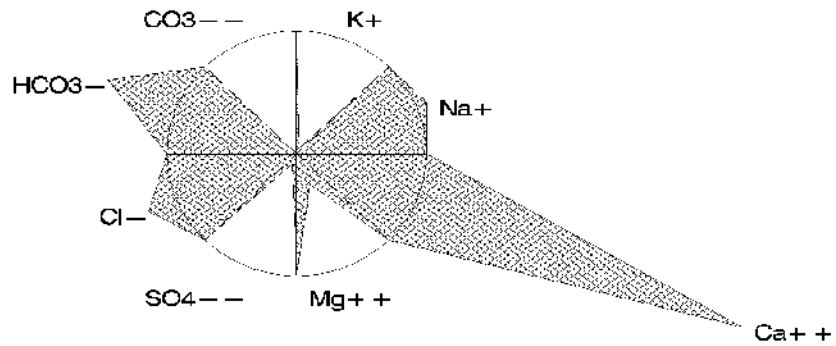

Spivey Lake, Citrus County

Todd Lake

Citrus County

USGS Quadrangle: Stokes Ferry Major Land Use/Land Cover (1990)
 Section/Township/Range: 13-18S-19E within 500 meters of the lakeshore:
 Approx. Lake Center, Lat/Long: 285552/822148 - cropland and pastureland (36%)
 Surface Area: 191 acres - medium density residential (32%)
 Approx. Lake Elevation: 39 feet - freshwater marshes (16%)
 Average Depth: 8.9 feet
 Observed Maximum Depth: 12 feet
 (reference elevation not given)
 Lake Type: inflow and outflow (type 3)
 Major Basin: Withlacoochee River
 Minor Basin: Tsala Apopka Outlet
 Lake Region: Tsala Apopka
 Public Access: yes

Total Number of Samples Collected: 2 Most Recent Sample Collected: January 1997

Parameter	Units (Detection Limit)	Average Value	District Percentile	Florida Percentile
Chlorophyll a	ug/l (1)	7.6	55	32
Total Phosphorus	mg/l as P (0.01)	0.010	33	5
Total Nitrogen	mg/l as N (0.06)	0.77	25	24
Transparency (Secchi depth)	meters	1.84	59	82
Florida Trophic State Index		29	23	<5
Specific Conductance	S/cm at 25C (1)	108	15	26
pH	standard units (0.1)	7.3	50	45
Color	PtCo units (1)	35	70	27
Turbidity	NTU (1)	0.5	28	<5
Total Alkalinity	mg/l as CaCO3 (1)	36	67	53
Hardness	mg/l as CaCO3 (0.02)	44	43	
Total Suspended Solids	mg/l (0.05)	0.4	8	
Ammonia	mg/l as N (0.03)	0.026	60	
Nitrate+Nitrite	mg/l as N (0.01)	0.005	33	
Total Kjeldahl Nitrogen	mg/l as N (0.06)	0.77	31	
Orthophosphorus	mg/l as P (0.01)	0.005	56	
Chloride	mg/l (0.05)	10	15	
Sulfate	mg/l (0.05)	0	<5	
Sodium	mg/l (0.06)	6.0	22	
Potassium	mg/l (0.07)	0.5	11	
Calcium	mg/l (0.04)	15.6	62	
Magnesium	mg/l (0.006)	1.2	10	
Iron	ug/l (0.03)	43	56	

Todd Lake is in the Hernando Pool of the Lake Tsala Apopka chain. Based upon the average FTSI of 29, water quality is considered good. Todd Lake can be characterized as a moderately colored, soft water, meso-eutrophic lake. The chemical type of water (predominant ionic composition) is calcium bicarbonate.

Plots and Trends: The plot of lake elevation is for the Hernando Pool of Lake Tsala Apopka. No trend in elevation is evident. Also shown is a diagram of the relative ionic composition of the lake water.

MONTHLY AVERAGE SURFACE ELEVATION

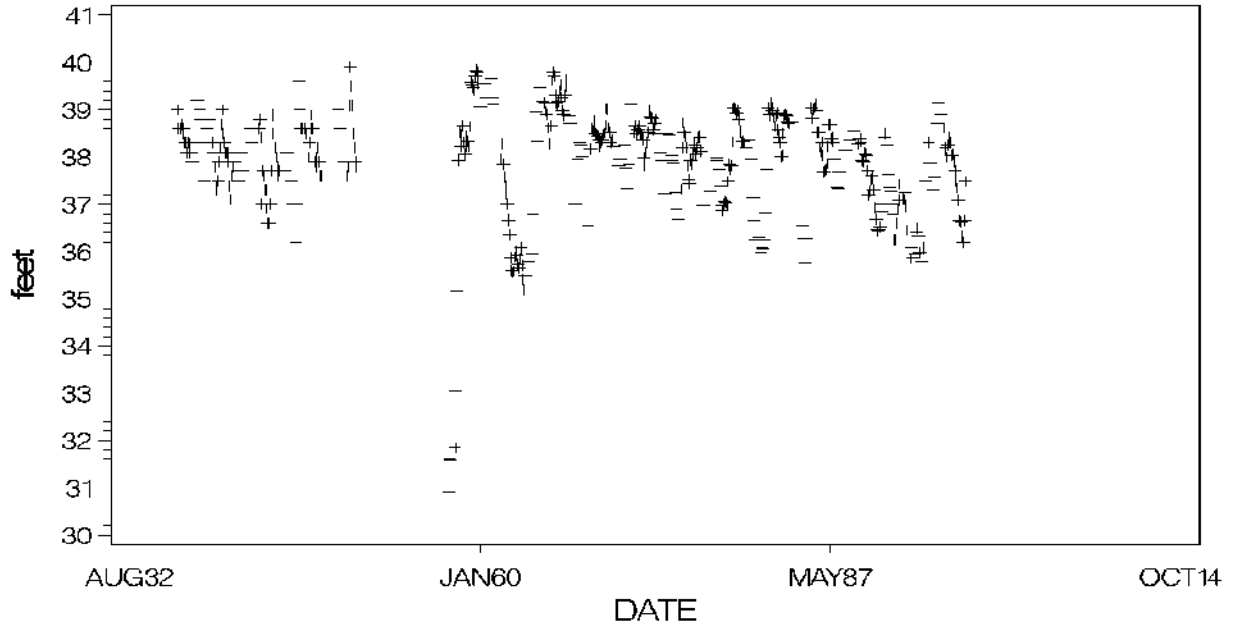

MAJOR IONS (% meq/l)

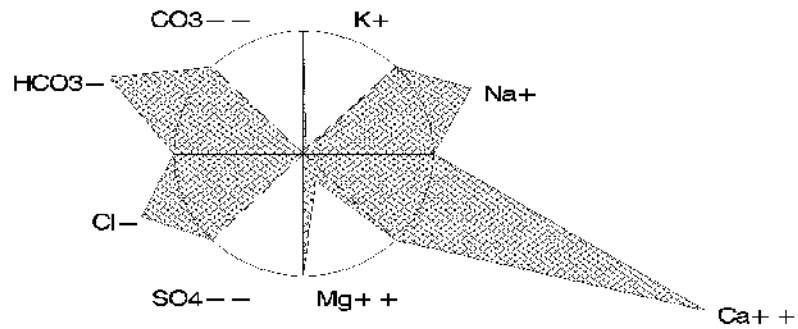

Todd Lake, Citrus County

Tussock Lake

Citrus County

USGS Quadrangle: Inverness Major Land Use/Land Cover (1990)
 Section/Township/Range: 35-19S-20E within 500 meters of the lakeshore:
 Approx. Lake Center, Lat/Long: 284744/821618 - freshwater marshes (31%)
 Surface Area: 205 acres - hardwood - conifer mixed (24%)
 Approx. Lake Elevation: 43 feet - open land (10%)
 Lake Type: inflow and outflow (type 3)
 Major Basin: Withlacoochee River
 Minor Basin: Tsala Apopka Outlet
 Lake Region: Tsala Apopka
 Public Access: yes

Total Number of Samples Collected: 2 Most Recent Sample Collected: January 1997

Parameter	Units (Detection Limit)	Average Value	District Percentile	Florida Percentile
Chlorophyll a	ug/l (1)	30.9	85	66
Total Phosphorus	mg/l as P (0.01)	0.014	50	7
Total Nitrogen	mg/l as N (0.06)	0.77	25	24
Transparency (Secchi depth)	meters	0.98	33	63
Florida Trophic State Index		47	68	29
Specific Conductance	S/cm at 25C (1)	122	21	32
pH	standard units (0.1)	7.3	50	45
Color	PtCo units (1)	113	91	82
Turbidity	NTU (1)	2.8	61	30
Total Alkalinity	mg/l as CaCO3 (1)	43	75	58
Hardness	mg/l as CaCO3 (0.02)	59	61	
Total Suspended Solids	mg/l (0.05)	2.4	57	
Ammonia	mg/l as N (0.03)	0.015	60	
Nitrate+Nitrite	mg/l as N (0.01)	0.010	34	
Total Kjeldahl Nitrogen	mg/l as N (0.06)	0.77	31	
Orthophosphorus	mg/l as P (0.01)	0.005	56	
Chloride	mg/l (0.05)	9	12	
Sulfate	mg/l (0.05)	1	6	
Sodium	mg/l (0.06)	5.0	12	
Potassium	mg/l (0.07)	0.7	14	
Calcium	mg/l (0.04)	21.6	80	
Magnesium	mg/l (0.006)	1.3	12	
Iron	ug/l (0.03)	179	91	

Tussock Lake is in the Floral City Pool of the Lake Tsala Apopka chain. Based upon the average FTSI of 47, water quality is considered good. Tussock Lake can be characterized as a highly colored, soft water, eutrophic lake. The chemical type of water (predominant ionic composition) is calcium bicarbonate.

Plots and Trends: The plot of lake elevation is for the Floral City Pool of Lake Tsala Apopka. No trend in elevation is evident. Also shown is a diagram of the relative ionic composition of the lake water.

MONTHLY AVERAGE SURFACE ELEVATION

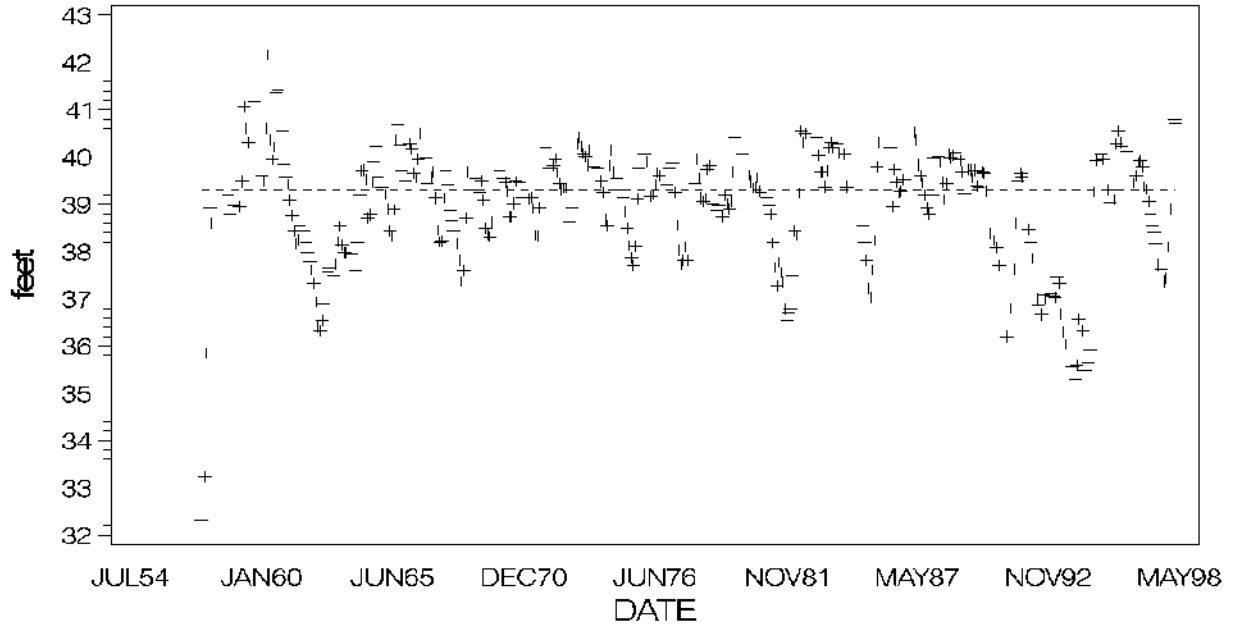

MAJOR IONS (% meq/l)

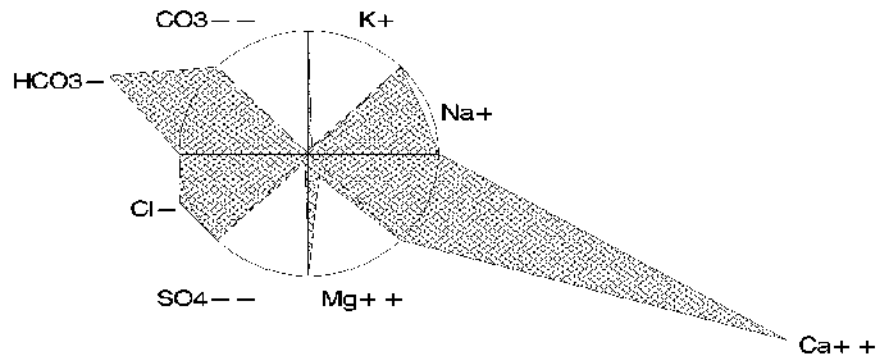

Van Ness Lake

Citrus County

USGS Quadrangle: Stokes Ferry Major Land Use/Land Cover (1990)
 Section/Township/Range: 29-18S-20E within 500 meters of the lakeshore:
 Approx. Lake Center, Lat/Long: 285315/822008 - cropland and pastureland (53%)
 Surface Area: 106 acres - freshwater marshes (19%)
 Approx. Lake Elevation: 39 feet - other open lands - rural (10%)
 Average Depth: 5.9 feet
 (reference elevation 36 feet)
 Lake Type: inflow and outflow (type 3)
 Major Basin: Withlacoochee River
 Minor Basin: Tsala Apopka Outlet
 Lake Region: Tsala Apopka
 Public Access: yes

Total Number of Samples Collected: 2 Most Recent Sample Collected: January 1997

Parameter	Units (Detection Limit)	Average Value	District Percentile	Florida Percentile
Chlorophyll a	ug/l (1)	4.3	39	17
Total Phosphorus	mg/l as P (0.01)	0.005	31	<5
Total Nitrogen	mg/l as N (0.06)	0.62	12	16
Transparency (Secchi depth)	meters	1.69	56	80
Florida Trophic State Index		27	20	<5
Specific Conductance	S/cm at 25C (1)	115	18	29
pH	standard units (0.1)	7.3	50	45
Color	PtCo units (1)	55	80	45
Turbidity	NTU (1)	0.5	28	<5
Total Alkalinity	mg/l as CaCO3 (1)	39	70	55
Hardness	mg/l as CaCO3 (0.02)	49	51	
Total Suspended Solids	mg/l (0.05)	0.3	<5	
Ammonia	mg/l as N (0.03)	0.015	60	
Nitrate+Nitrite	mg/l as N (0.01)	0.010	34	
Total Kjeldahl Nitrogen	mg/l as N (0.06)	0.62	17	
Orthophosphorus	mg/l as P (0.01)	0.005	56	
Chloride	mg/l (0.05)	10	15	
Sulfate	mg/l (0.05)	1	6	
Sodium	mg/l (0.06)	5.9	21	
Potassium	mg/l (0.07)	0.8	16	
Calcium	mg/l (0.04)	17.2	66	
Magnesium	mg/l (0.006)	1.3	12	
Iron	ug/l (0.03)	66	70	

Van Ness Lake is in the Hernando Pool of the Lake Tsala Apopka chain. Based upon the average FTSI of 27, water quality is considered good. Van Ness Lake can be characterized as a colored, soft water, oligo-mesotrophic lake, with low concentrations of total phosphorus. The chemical type of water (predominant ionic composition) is calcium bicarbonate.

Plots and Trends: The plot of lake elevation is for the Hernando Pool of Lake Tsala Apopka. No trend in elevation is evident. Also shown is a diagram of the relative ionic composition of the lake water.

MONTHLY AVERAGE SURFACE ELEVATION

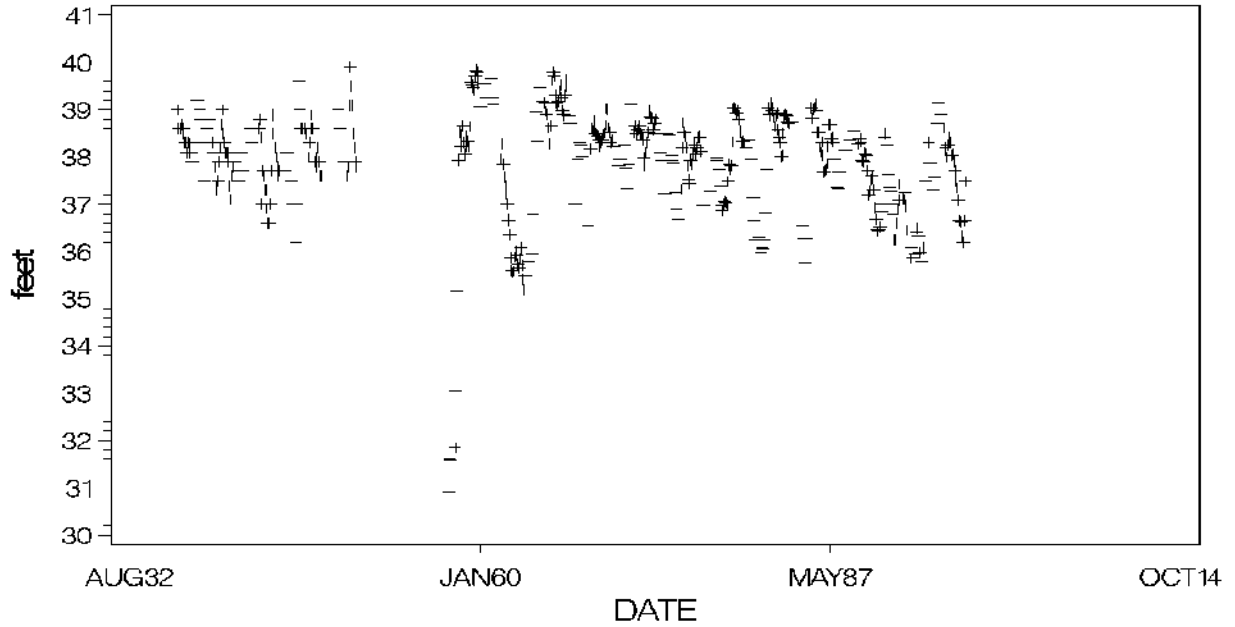

MAJOR IONS (% meq/l)

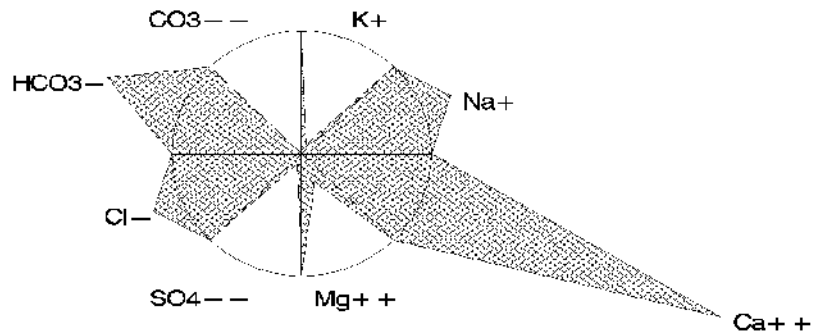

Bonnett Pond

Hernando County

USGS Quadrangle: Brooksville Major Land Use/Land Cover (1990)
 Section/Township/Range: 28-22S-19E within 500 meters of the lakeshore:
 Approx. Lake Center, Lat/Long: 283221/822452 - hardwood - conifer mixed (39%)
 Surface Area: 12 acres - cropland and pastureland (14%)
 Approx. Lake Elevation: 68 feet - low density residential (13%)
 Lake Type: isolated (type 4)
 Major Basin: Upper Coastal Drainage
 Minor Basin: Pecks Sink
 Lake Region: Southern Brooksville Ridge

Total Number of Samples Collected: 13 Most Recent Sample Collected: September 1995

Parameter	Units (Detection Limit)	Average Value	District Percentile	Florida Percentile
Chlorophyll a	ug/l (1)	18.3	78	50
Total Phosphorus	mg/l as P (0.01)	0.076	91	56
Total Nitrogen	mg/l as N (0.06)	1.40	66	50
Transparency (Secchi depth)	meters	0.55	13	25
Florida Trophic State Index		66	92	69
Specific Conductance	S/cm at 25C (1)	114	17	29
pH	standard units (0.1)	7.8	74	63
Color	PtCo units (1)	17	48	15
Turbidity	NTU (1)	11.2	90	72
Total Alkalinity	mg/l as CaCO3 (1)	41	72	57
Hardness	mg/l as CaCO3 (0.02)	52	54	
Total Suspended Solids	mg/l (0.05)	13.2	95	
Ammonia	mg/l as N (0.03)	0.025	60	
Nitrate+Nitrite	mg/l as N (0.01)	0.010	34	
Total Kjeldahl Nitrogen	mg/l as N (0.06)	1.39	74	
Orthophosphorus	mg/l as P (0.01)	0.015	80	
Chloride	mg/l (0.05)	5	<5	
Sulfate	mg/l (0.05)	1	6	
Sodium	mg/l (0.06)	2.9	<5	
Potassium	mg/l (0.07)	1.5	25	
Calcium	mg/l (0.04)	18.7	72	
Magnesium	mg/l (0.006)	1.3	12	
Iron	ug/l (0.03)	292	>95	

Based upon the average FTSI of 66, water quality is considered fair. Bonnett Pond can be characterized as a clear to moderately colored (color<=20 color units), soft water, meso-eutrophic lake, with high concentrations of total phosphorus. The chemical type of water (predominant ionic composition) is calcium bicarbonate.

Plots and Trends: No or insufficient data for plotting or trend detection. Also shown is a diagram of the relative ionic composition of the lake water.

MAJOR IONS (% meq/l)

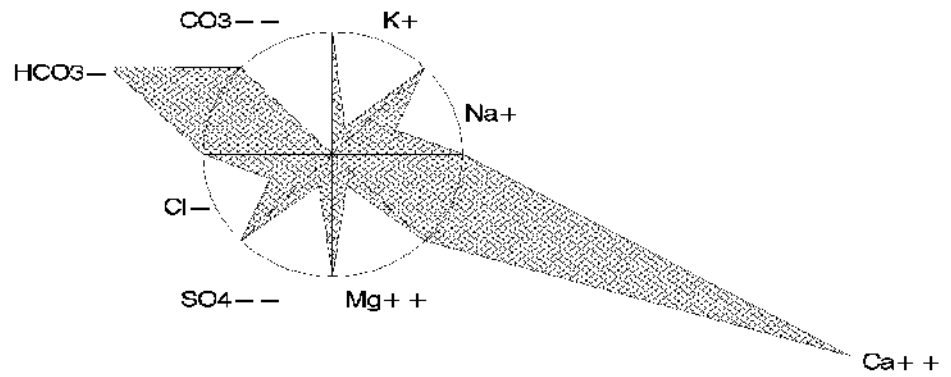

Bonnett Pond, Hernando County

Bystre Lake

Hernando County

USGS Quadrangle: Brooksville SE Major Land Use/Land Cover (1990)
 Section/Township/Range: 29-22S-20E within 500 meters of the lakeshore:
 Approx. Lake Center, Lat/Long: 283237/821934 - cropland and pastureland (52%)
 Surface Area: 307 acres - low density residential (10%)
 Approx. Lake Elevation: 72 feet - medium density residential (8%)
 Lake Type: inflow and outflow (type 3)
 Major Basin: Withlacoochee River
 Minor Basin: Withlacoochee River
 Lake Region: Southern Brooksville Ridge

Total Number of Samples Collected: 12 Most Recent Sample Collected: September 1995

Parameter	Units (Detection Limit)	Average Value	District Percentile	Florida Percentile
Chlorophyll a	ug/l (1)	10.1	64	38
Total Phosphorus	mg/l as P (0.01)	0.123	95	73
Total Nitrogen	mg/l as N (0.06)	1.09	48	36
Transparency (Secchi depth)	meters	1.28	44	72
Florida Trophic State Index		46	66	28
Specific Conductance	S/cm at 25C (1)	181	51	48
pH	standard units (0.1)	7.8	74	63
Color	PtCo units (1)	27	64	21
Turbidity	NTU (1)	1.9	49	19
Total Alkalinity	mg/l as CaCO3 (1)	82	95	78
Hardness	mg/l as CaCO3 (0.02)	93	89	
Total Suspended Solids	mg/l (0.05)	2.7	61	
Ammonia	mg/l as N (0.03)	0.047	73	
Nitrate+Nitrite	mg/l as N (0.01)	0.011	37	
Total Kjeldahl Nitrogen	mg/l as N (0.06)	1.08	54	
Orthophosphorus	mg/l as P (0.01)	0.067	95	
Chloride	mg/l (0.05)	9	12	
Sulfate	mg/l (0.05)	1	6	
Sodium	mg/l (0.06)	5.6	18	
Potassium	mg/l (0.07)	4.0	56	
Calcium	mg/l (0.04)	33.0	95	
Magnesium	mg/l (0.006)	2.6	38	
Iron	ug/l (0.03)	99	81	

Based upon the average FTSI of 46, water quality is considered good. Bystre Lake can be characterized as a moderately colored, medium hard water, meso-eutrophic lake, with high concentrations of total phosphorus. The chemical type of water (predominant ionic composition) is calcium bicarbonate (6 samples) or calcium carbonate (6 samples).

Plots and Trends: No or insufficient data for plotting or trend detection. Shown is a diagram of the relative ionic composition of the lake water.

MAJOR IONS (% meq/l)

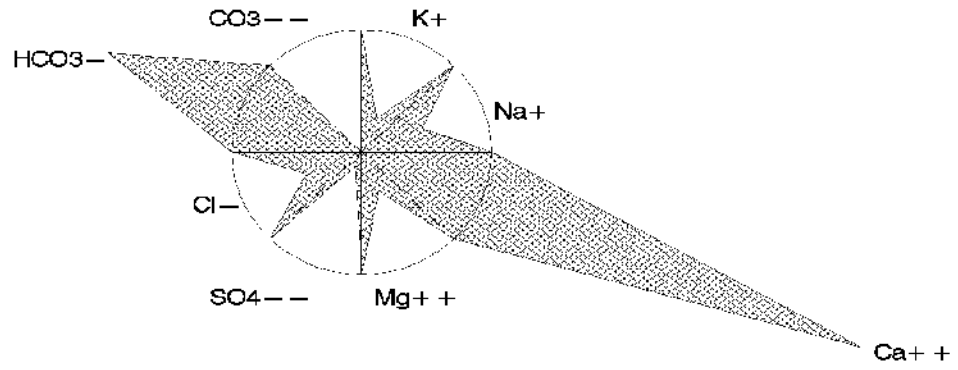

Bystre Lake, Hernando County

Double Cypress Pond Hernando County

USGS Quadrangle: Weeki Wachee Springs
 Section/Township/Range: 23-22S-17E
 Approx. Lake Center, Lat/Long: 283323/823411
 Surface Area: 28 acres
 Approx. Lake Elevation: 17 feet
 Lake Type: isolated (type 4)
 Major Basin: Upper Coastal Drainage
 Minor Basin: Weekiwachee River
 Lake Region: Weeki Wachee Hills

Major Land Use/Land Cover (1990)
 within 500 meters of the lakeshore:
 - longleaf pine - xeric pine (48%)
 - open land (24%)
 - recreational (6%)

Total Number of Samples Collected: 2 Most Recent Sample Collected: January 1996

Parameter	Units (Detection Limit)	Average Value	District Percentile	Florida Percentile
Chlorophyll a	ug/l (1)	3.3	28	14
Total Phosphorus	mg/l as P (0.01)	0.017	58	9
Total Nitrogen	mg/l as N (0.06)	1.37	64	49
Transparency (Secchi depth)	meters	0.50	9	20
Florida Trophic State Index		41	55	17
Specific Conductance	S/cm at 25C (1)	366	94	74
pH	standard units (0.1)	6.7	21	23
Color	PtCo units (1)	125	92	85
Turbidity	NTU (1)	21.2	>95	83
Total Alkalinity	mg/l as CaCO3 (1)	8	21	22
Hardness	mg/l as CaCO3 (0.02)	17	7	
Total Suspended Solids	mg/l (0.05)	3.2	65	
Ammonia	mg/l as N (0.03)	0.046	72	
Nitrate+Nitrite	mg/l as N (0.01)	0.040	65	
Total Kjeldahl Nitrogen	mg/l as N (0.06)	1.33	70	
Orthophosphorus	mg/l as P (0.01)	0.013	72	
Chloride	mg/l (0.05)	6	5	
Sulfate	mg/l (0.05)	7	27	
Sodium	mg/l (0.06)	3.7	7	
Potassium	mg/l (0.07)	0.3	7	
Calcium	mg/l (0.04)	5.9	19	
Magnesium	mg/l (0.006)	0.6	<5	
Iron	ug/l (0.03)	144	88	

Based upon the average FTSI of 41, water quality is considered good. Double Cypress Pond can be characterized as a highly colored, soft water, oligo-mesotrophic lake. The chemical type of water (predominant ionic composition) is calcium chloride.

Plots and Trends: No or insufficient data for plotting or trend detection. Shown is a diagram of the relative ionic composition of the lake water.

MAJOR IONS (% meq/l)

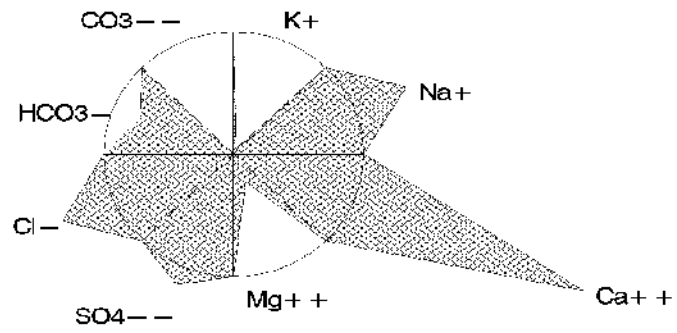

Double Cypress Pond, Hernando County

Lake Geneva Hernando County

USGS Quadrangle: Saint Catherine
 Section/Township/Range: 11-23S-21E
 Approx. Lake Center, Lat/Long: 283008/821057
 Surface Area: 59 acres
 Approx. Lake Elevation: 60 feet
 Lake Type: inflow and outflow (type 3)
 Major Basin: Withlacoochee River
 Minor Basin: Lake Elizabeth Outlet
 Lake Region: Southern Brooksville Ridge

Major Land Use/Land Cover (1990)
 within 500 meters of the lakeshore:
 - medium density residential (24%)
 - hardwood - conifer mixed (23%)
 - low density residential (15%)

Total Number of Samples Collected: 9 Most Recent Sample Collected: September 1995

Parameter	Units (Detection Limit)	Average Value	District Percentile	Florida Percentile
Chlorophyll a	ug/l (1)	7.1	53	31
Total Phosphorus	mg/l as P (0.01)	0.050	87	40
Total Nitrogen	mg/l as N (0.06)	1.62	73	66
Transparency (Secchi depth)	meters	0.81	25	51
Florida Trophic State Index		51	74	36
Specific Conductance	S/cm at 25C (1)	109	16	27
pH	standard units (0.1)	6.9	29	28
Color	PtCo units (1)	172	>95	94
Turbidity	NTU (1)	2.9	62	31
Total Alkalinity	mg/l as CaCO3 (1)	28	55	47
Hardness	mg/l as CaCO3 (0.02)	45	46	
Total Suspended Solids	mg/l (0.05)	2.9	64	
Ammonia	mg/l as N (0.03)	0.164	95	
Nitrate+Nitrite	mg/l as N (0.01)	0.066	76	
Total Kjeldahl Nitrogen	mg/l as N (0.06)	1.56	79	
Orthophosphorus	mg/l as P (0.01)	0.009	56	
Chloride	mg/l (0.05)	11	19	
Sulfate	mg/l (0.05)	1	6	
Sodium	mg/l (0.06)	6.4	25	
Potassium	mg/l (0.07)	0.9	17	
Calcium	mg/l (0.04)	15.1	61	
Magnesium	mg/l (0.006)	1.7	20	
Iron	ug/l (0.03)	254	94	

Based upon the average FTSI of 51, water quality is considered good. Lake Geneva can be characterized as a highly colored, soft water, meso-eutrophic lake, with high concentrations of total phosphorus. The chemical type of water (predominant ionic composition) is calcium bicarbonate.

Plots and Trends: The plot of lake surface elevation shows lake levels have been stable, however, the range of lake level fluctuation in the lake was nearly 15 feet over the period of record. Also shown is a diagram of the relative ionic composition of the lake water.

MONTHLY AVERAGE SURFACE ELEVATION

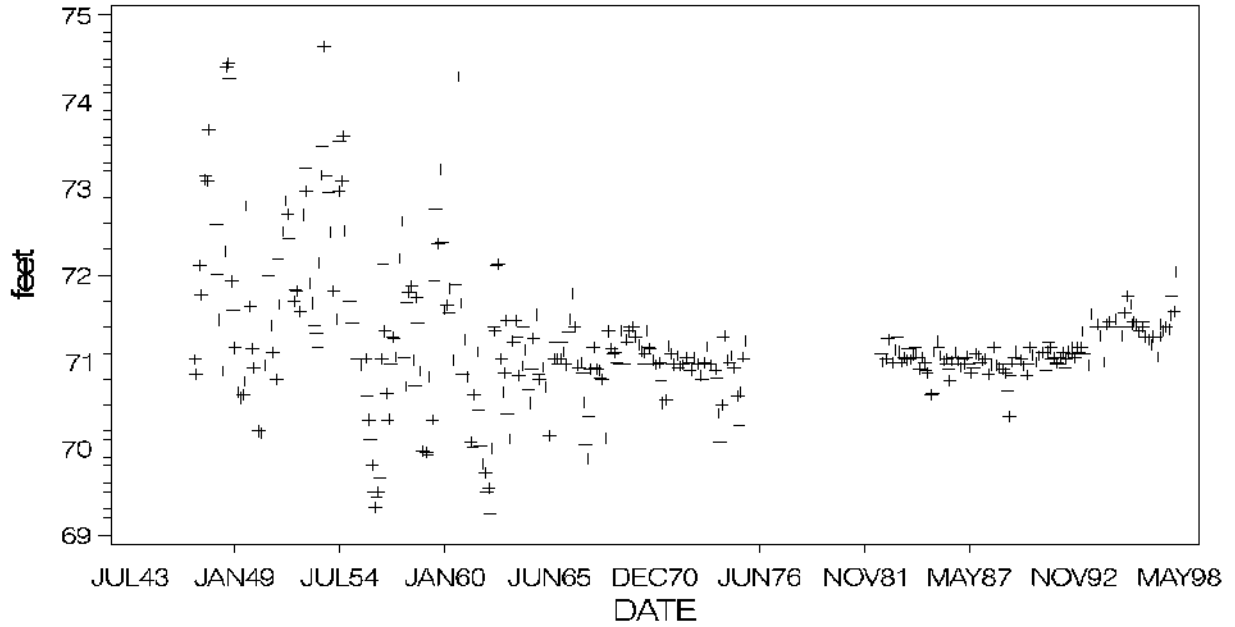

MAJOR IONS (% meq/l)

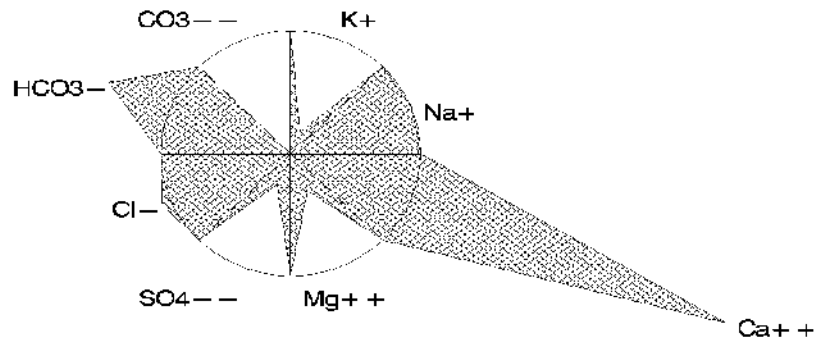

Highland Lake

Hernando County

USGS Quadrangle: Weeki Wachee Springs Major Land Use/Land Cover (1990)
 Section/Township/Range: 24-22S-17E within 500 meters of the lakeshore:
 Approx. Lake Center, Lat/Long: 283308/823341 - longleaf pine - xeric pine (21%)
 Surface Area: 51 acres - open land (16%)
 Approx. Lake Elevation: 18 feet - freshwater marshes (15%)
 Lake Type: isolated (type 4)
 Major Basin: Upper Coastal Drainage
 Minor Basin: Weekiwachee River
 Lake Region: Weeki Wachee Hills

Total Number of Samples Collected: 3 Most Recent Sample Collected: January 1996

Parameter	Units (Detection Limit)	Average Value	District Percentile	Florida Percentile
Chlorophyll a	ug/l (1)	2.5	18	11
Total Phosphorus	mg/l as P (0.01)	0.007	31	<5
Total Nitrogen	mg/l as N (0.06)	1.71	75	71
Transparency (Secchi depth)	meters	1.50	49	76
Florida Trophic State Index		29	25	<5
Specific Conductance	S/cm at 25C (1)	147	36	41
pH	standard units (0.1)	7.4	57	50
Color	PtCo units (1)	40	72	30
Turbidity	NTU (1)	0.5	28	<5
Total Alkalinity	mg/l as CaCO3 (1)	44	76	59
Hardness	mg/l as CaCO3 (0.02)	63	65	
Total Suspended Solids	mg/l (0.05)	0.9	24	
Ammonia	mg/l as N (0.03)	0.144	93	
Nitrate+Nitrite	mg/l as N (0.01)	0.021	53	
Total Kjeldahl Nitrogen	mg/l as N (0.06)	1.69	82	
Orthophosphorus	mg/l as P (0.01)	0.005	56	
Chloride	mg/l (0.05)	8	9	
Sulfate	mg/l (0.05)	14	48	
Sodium	mg/l (0.06)	4.9	12	
Potassium	mg/l (0.07)	0.4	9	
Calcium	mg/l (0.04)	23.7	85	
Magnesium	mg/l (0.006)	0.8	<5	
Iron	ug/l (0.03)	46	58	

Based upon the average FTSI of 29, water quality is considered good. Highland Lake can be characterized as a colored, medium hard water, oligotrophic lake, with low concentrations of total phosphorus. The chemical type of water (predominant ionic composition) is calcium bicarbonate.

Plots and Trends: No or insufficient data available for plotting or trend detection. Shown is a diagram of the relative ionic composition of the lake water.

MAJOR IONS (% meq/l)

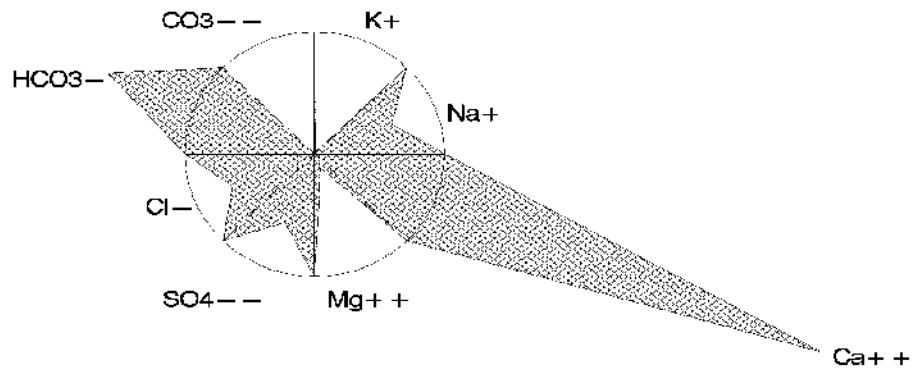

Highland Lake, Hernando County

Hunters Lake Hernando County

USGS Quadrangle: Port Richey NE Major Land Use/Land Cover (1990)
 Section/Township/Range: 32-23S-17E within 500 meters of the lakeshore:
 Approx. Lake Center, Lat/Long: 282634/823719 - medium density residential (68%)
 Surface Area: 302 acres - upland coniferous forests (10%)
 Approx. Lake Elevation: 19 feet - other open lands - rural (7%)
 Average Depth: 6 feet
 Observed Maximum Depth: 12 feet
 (reference elevation 19.1 feet)
 Lake Type: outflow (type 2)
 Major Basin: Upper Coastal Drainage
 Minor Basin: Hammock Creek
 Lake Region: Weeki Wachee Hills
 Public Access: yes

Total Number of Samples Collected: 13 Most Recent Sample Collected: September 1995

Parameter	Units (Detection Limit)	Average Value	District Percentile	Florida Percentile
Chlorophyll a	ug/l (1)	4.5	41	18
Total Phosphorus	mg/l as P (0.01)	0.023	69	13
Total Nitrogen	mg/l as N (0.06)	1.17	53	39
Transparency (Secchi depth)	meters	1.51	50	76
Florida Trophic State Index		38	48	13
Specific Conductance	S/cm at 25C (1)	159	42	44
pH	standard units (0.1)	7.7	69	60
Color	PtCo units (1)	7	18	7
Turbidity	NTU (1)	1.7	45	16
Total Alkalinity	mg/l as CaCO3 (1)	31	60	50
Hardness	mg/l as CaCO3 (0.02)	56	58	
Total Suspended Solids	mg/l (0.05)	2.8	62	
Ammonia	mg/l as N (0.03)	0.018	60	
Nitrate+Nitrite	mg/l as N (0.01)	0.008	33	
Total Kjeldahl Nitrogen	mg/l as N (0.06)	1.16	59	
Orthophosphorus	mg/l as P (0.01)	0.006	56	
Chloride	mg/l (0.05)	17	41	
Sulfate	mg/l (0.05)	8	31	
Sodium	mg/l (0.06)	9.3	55	
Potassium	mg/l (0.07)	0.5	11	
Calcium	mg/l (0.04)	20.1	76	
Magnesium	mg/l (0.006)	1.5	16	
Iron	ug/l (0.03)	23	28	

Based upon the average FTSI of 38, water quality is considered good. Hunters Lake can be characterized as a clear (color<=10 color units), soft water, oligo-mesotrophic lake. The chemical type of water (predominant ionic composition) is calcium chloride.

Plots and Trends: Lake surface elevations have ranged approximately 8 feet over the period of record. No trend is evident. Data for the measures of water chemistry are sporadic. The few data points shown for samples collected around 1965 suggest that specific conductance, pH, total alkalinity and hardness were lower at that time than for samples collected during the 1980s and the 1990s. However, due to the large gaps in the available data it can not be concluded that these apparent changes represent trends. Also shown is a diagram of the relative ionic composition of the lake water.

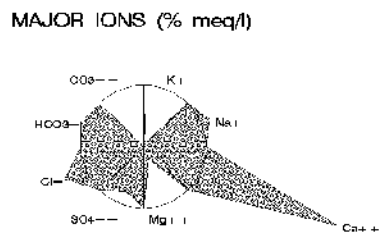
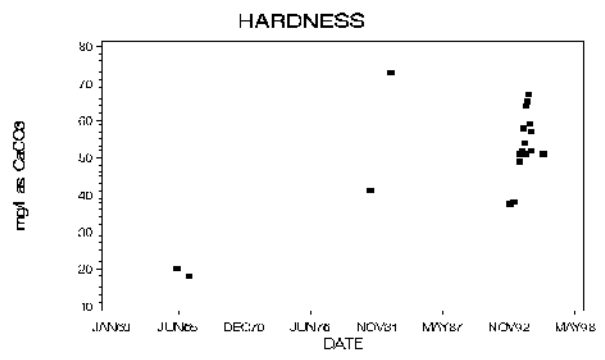
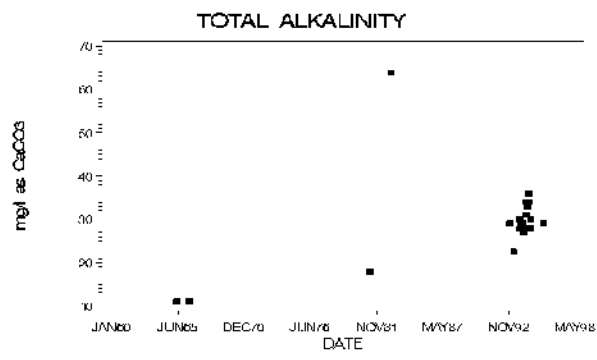
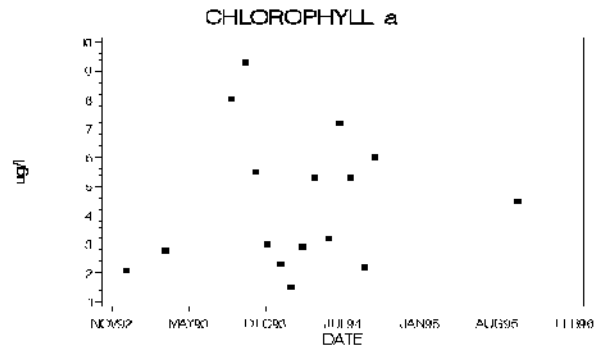
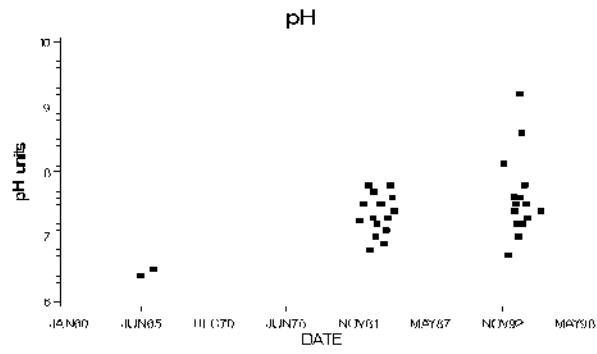
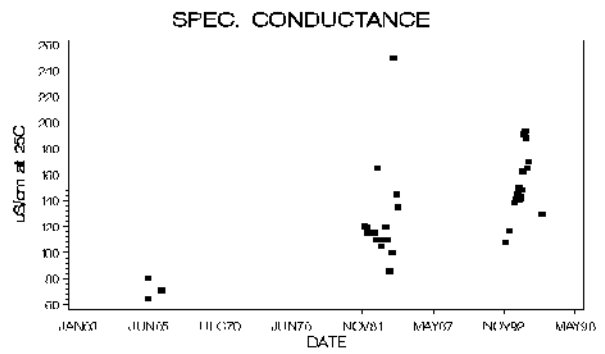
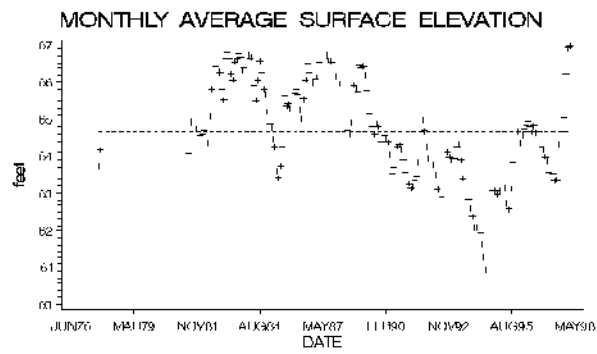

Hunters Lake, Hernando County

Irvin Lake

Hernando County

USGS Quadrangle: Brooksville SE Major Land Use/Land Cover (1990)
 Section/Township/Range: 36-22S-19E within 500 meters of the lakeshore:
 Approx. Lake Center, Lat/Long: 283129/822141 - other open lands - rural (36%)
 Surface Area: 38 acres - cropland and pastureland (20%)
 Approx. Lake Elevation: 86 feet - hardwood - conifer mixed (18%)
 Lake Type: inflow and outflow (type 3)
 Major Basin: Withlacoochee River
 Minor Basin: Withlacoochee River
 Lake Region: Southern Brooksville Ridge

Total Number of Samples Collected: 2 Most Recent Sample Collected: February 1996

Parameter	Units (Detection Limit)	Average Value	District Percentile	Florida Percentile
Chlorophyll a	ug/l (1)	35.4	88	71
Total Phosphorus	mg/l as P (0.01)	0.190	>95	83
Total Nitrogen	mg/l as N (0.06)	2.22	88	84
Transparency (Secchi depth)	meters	0.51	11	21
Florida Trophic State Index		73	>95	87
Specific Conductance	S/cm at 25C (1)	86	10	18
pH	standard units (0.1)	8.3	87	78
Color	PtCo units (1)	93	88	74
Turbidity	NTU (1)	11.1	89	71
Total Alkalinity	mg/l as CaCO3 (1)	29	57	48
Hardness	mg/l as CaCO3 (0.02)	34	27	
Total Suspended Solids	mg/l (0.05)	10.5	91	
Ammonia	mg/l as N (0.03)	0.047	73	
Nitrate+Nitrite	mg/l as N (0.01)	0.020	51	
Total Kjeldahl Nitrogen	mg/l as N (0.06)	2.20	94	
Orthophosphorus	mg/l as P (0.01)	0.124	>95	
Chloride	mg/l (0.05)	6	5	
Sulfate	mg/l (0.05)	4	17	
Sodium	mg/l (0.06)	3.3	<5	
Potassium	mg/l (0.07)	2.7	44	
Calcium	mg/l (0.04)	10.9	41	
Magnesium	mg/l (0.006)	1.7	20	
Iron	ug/l (0.03)	153	88	

Based upon the average FTSI of 73, water quality is considered poor. Irvin Lake can be characterized as a highly colored, soft water, eutrophic lake, with high concentrations of total phosphorus and high concentrations of total nitrogen. The chemical type of water (predominant ionic composition) is calcium bicarbonate.

Also of note:

- The measured pH was high.

Plots and Trends: No or insufficient data available for plotting or trend detection. Shown is a diagram of the relative ionic composition of the lake water.

MAJOR IONS (% meq/l)

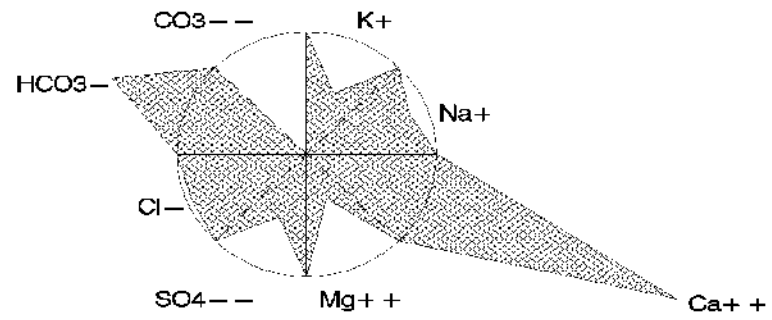

Irvin Lake, Hernando County

Lake Lindsey

Hernando County

USGS Quadrangle: Nobleton
 Section/Township/Range: 25-21S-19E
 Approx. Lake Center, Lat/Long: 283746/822159
 Surface Area: 137 acres
 Approx. Lake Elevation: 69 feet
 Lake Type: inflow and outflow (type 3)
 Major Basin: Withlacoochee River
 Minor Basin: Withlacoochee River
 Lake Region: Southern Brooksville Ridge
 Public Access: yes

Major Land Use/Land Cover (1990)
 within 500 meters of the lakeshore:
 - hardwood - conifer mixed (41%)
 - specialty farms inc. horse, dairy, kennels (13%)
 - cropland and pastureland (12%)

Total Number of Samples Collected: 12 Most Recent Sample Collected: September 1995

Parameter	Units (Detection Limit)	Average Value	District Percentile	Florida Percentile
Chlorophyll a	ug/l (1)	5.7	47	24
Total Phosphorus	mg/l as P (0.01)	0.024	71	14
Total Nitrogen	mg/l as N (0.06)	0.90	32	30
Transparency (Secchi depth)	meters	0.97	32	62
Florida Trophic State Index		35	40	9
Specific Conductance	S/cm at 25C (1)	42	<5	<5
pH	standard units (0.1)	6.2	8	10
Color	PtCo units (1)	25	62	20
Turbidity	NTU (1)	0.8	28	<5
Total Alkalinity	mg/l as CaCO3 (1)	12	31	29
Hardness	mg/l as CaCO3 (0.02)	21	10	
Total Suspended Solids	mg/l (0.05)	0.9	24	
Ammonia	mg/l as N (0.03)	0.022	60	
Nitrate+Nitrite	mg/l as N (0.01)	0.008	33	
Total Kjeldahl Nitrogen	mg/l as N (0.06)	0.89	38	
Orthophosphorus	mg/l as P (0.01)	0.006	56	
Chloride	mg/l (0.05)	5	<5	
Sulfate	mg/l (0.05)	1	6	
Sodium	mg/l (0.06)	1.4	<5	
Potassium	mg/l (0.07)	0.1	<5	
Calcium	mg/l (0.04)	6.7	22	
Magnesium	mg/l (0.006)	1.0	6	
Iron	ug/l (0.03)	85	77	

Based upon the average FTSI of 35, water quality is considered good. Lake Lindsey can be characterized as a moderately colored, soft water, oligo-mesotrophic lake. The chemical type of water (predominant ionic composition) is calcium bicarbonate (3 samples) or calcium chloride (9 samples).

Plots and Trends: Though fluctuating through a range of approximately 8 feet, lake levels have remained relatively stable over the interrupted period of record. Measures of water chemistry made during the 1990s are consistent with those made in the 1960s; no trends are evident. Also shown is a diagram of the relative ionic composition of the lake water.

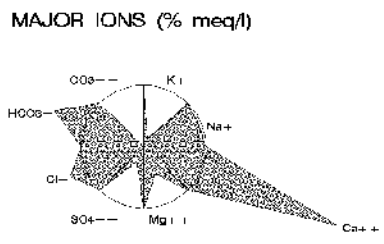
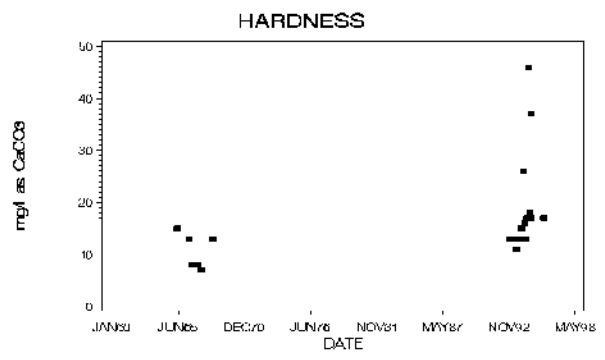
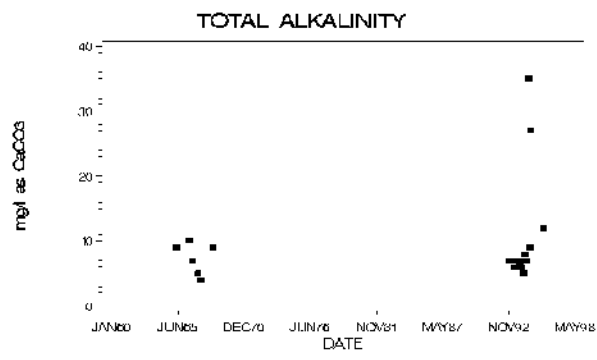
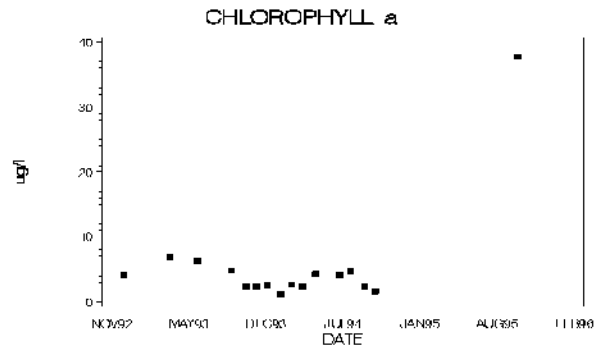
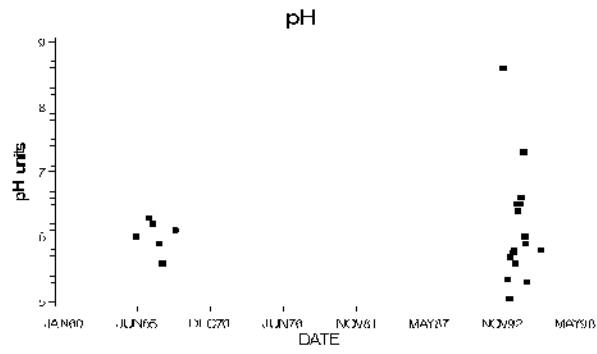
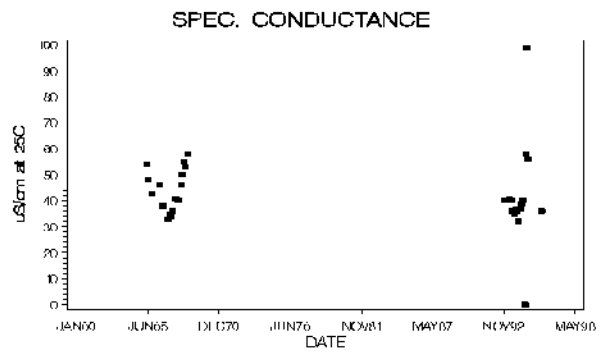
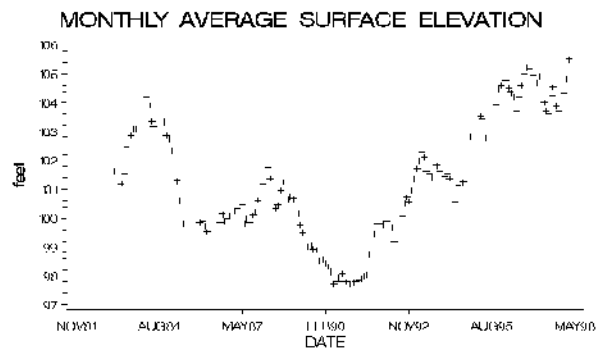

Lake Lindsey, Hernando County

McClendon Lake

Hernando County

USGS Quadrangle: Spring Lake Major Land Use/Land Cover (1990)
 Section/Township/Range: 35-23S-20E within 500 meters of the lakeshore:
 Approx. Lake Center, Lat/Long: 282620/821638 - hardwood - conifer mixed (26%)
 Surface Area: 76 acres - stream and lake swamps (23%)
 Approx. Lake Elevation: 108 feet - other open lands - rural (17%)
 Lake Type: isolated (type 4)
 Major Basin: Withlacoochee River
 Minor Basin: Withlacoochee River
 Lake Region: Southern Brooksville Ridge

Total Number of Samples Collected: 2 Most Recent Sample Collected: January 1996

Parameter	Units (Detection Limit)	Average Value	District Percentile	Florida Percentile
Chlorophyll a	ug/l (1)	122.4	>95	>95
Total Phosphorus	mg/l as P (0.01)	0.098	94	66
Total Nitrogen	mg/l as N (0.06)	1.74	77	72
Transparency (Secchi depth)	meters	0.25	<5	<5
Florida Trophic State Index		85	>95	>95
Specific Conductance	S/cm at 25C (1)	79	7	15
pH	standard units (0.1)	6.8	25	25
Color	PtCo units (1)	138	93	88
Turbidity	NTU (1)	15.2	94	77
Total Alkalinity	mg/l as CaCO3 (1)	24	48	43
Hardness	mg/l as CaCO3 (0.02)	36	29	
Total Suspended Solids	mg/l (0.05)	9.5	89	
Ammonia	mg/l as N (0.03)	0.047	73	
Nitrate+Nitrite	mg/l as N (0.01)	0.067	76	
Total Kjeldahl Nitrogen	mg/l as N (0.06)	1.67	81	
Orthophosphorus	mg/l as P (0.01)	0.025	88	
Chloride	mg/l (0.05)	14	30	
Sulfate	mg/l (0.05)	2	10	
Sodium	mg/l (0.06)	5.5	16	
Potassium	mg/l (0.07)	1.3	22	
Calcium	mg/l (0.04)	8.5	30	
Magnesium	mg/l (0.006)	3.5	52	
Iron	ug/l (0.03)	652	>95	

Based upon the average FTSI of 85, water quality is considered poor. McClendon Lake can be characterized as a highly colored, soft water, hypereutrophic lake, with high concentrations of total phosphorus. The chemical type of water (predominant ionic composition) is calcium chloride.

Plots and Trends: No or insufficient data available for plotting or trend detection. Shown is a diagram of the relative ionic composition of the lake water.

MAJOR IONS (% meq/l)

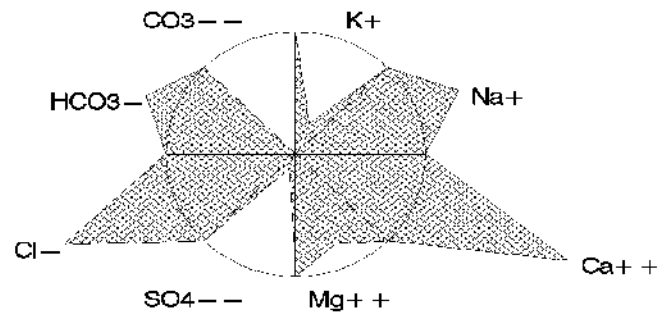

McClendon Lake, Hernando County

McKethan Lake

Hernando County

USGS Quadrangle: Nobleton Major Land Use/Land Cover (1990)
 Section/Township/Range: 19-21S-20E within 500 meters of the lakeshore:
 Approx. Lake Center, Lat/Long: 283849/822014 - hardwood - conifer mixed (64%)
 Surface Area: 57 acres - longleaf pine - xeric pine (9%)
 Approx. Lake Elevation: 64 feet - cropland and pastureland (9%)
 Lake Type: isolated (type 4)
 Major Basin: Withlacoochee River
 Minor Basin: McKethan Lake Outlet
 Lake Region: Southern Brooksville Ridge
 Public Access: yes

Total Number of Samples Collected: 2 Most Recent Sample Collected: January 1996

Parameter	Units (Detection Limit)	Average Value	District Percentile	Florida Percentile
Chlorophyll a	ug/l (1)	16.9	76	48
Total Phosphorus	mg/l as P (0.01)	0.025	72	15
Total Nitrogen	mg/l as N (0.06)	0.83	27	27
Transparency (Secchi depth)	meters	1.25	42	71
Florida Trophic State Index		55	79	45
Specific Conductance	S/cm at 25C (1)	33	<5	<5
pH	standard units (0.1)	6.8	25	25
Color	PtCo units (1)	68	83	58
Turbidity	NTU (1)	1.9	49	19
Total Alkalinity	mg/l as CaCO3 (1)	14	33	32
Hardness	mg/l as CaCO3 (0.02)	16	6	
Total Suspended Solids	mg/l (0.05)	2.2	55	
Ammonia	mg/l as N (0.03)	0.047	73	
Nitrate+Nitrite	mg/l as N (0.01)	0.011	37	
Total Kjeldahl Nitrogen	mg/l as N (0.06)	0.82	33	
Orthophosphorus	mg/l as P (0.01)	0.008	56	
Chloride	mg/l (0.05)	2	<5	
Sulfate	mg/l (0.05)	0	<5	
Sodium	mg/l (0.06)	1.5	<5	
Potassium	mg/l (0.07)	0.2	<5	
Calcium	mg/l (0.04)	4.7	13	
Magnesium	mg/l (0.006)	1.0	6	
Iron	ug/l (0.03)	83	76	

Based upon the average FTSI of 55, water quality is considered good. McKethan Lake can be characterized as a colored, soft water, eutrophic lake. The chemical type of water (predominant ionic composition) is calcium bicarbonate.

Plots and Trends: No or insufficient data available for plotting or trend detection. Shown is a diagram of the relative ionic composition of the lake water.

MAJOR IONS (% meq/l)

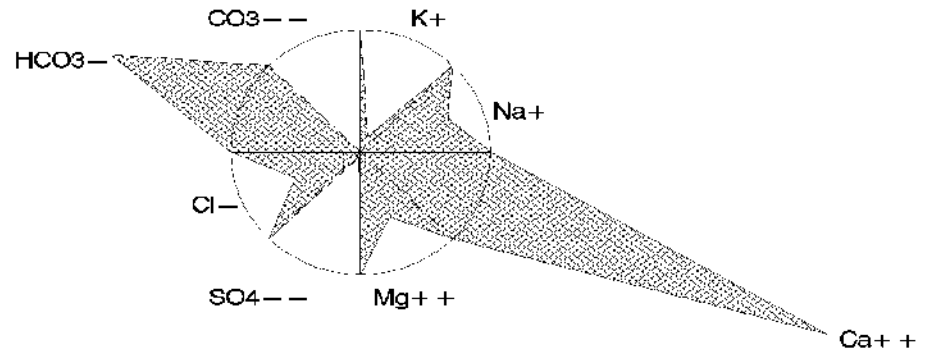

McKethan Lake, Hernando County

Rock Pond

Hernando County

USGS Quadrangle: Brooksville Major Land Use/Land Cover (1990)
 Section/Township/Range: 34-21S-19E within 500 meters of the lakeshore:
 Approx. Lake Center, Lat/Long: 283701/822320 - hardwood - conifer mixed (83%)
 Surface Area: 28 acres - low density residential (5%)
 Approx. Lake Elevation: 69 feet - pine flatwoods (5%)
 Lake Type: isolated (type 4)
 Major Basin: Withlacoochee River
 Minor Basin: Withlacoochee River
 Lake Region: Southern Brooksville Ridge

Total Number of Samples Collected: 2 Most Recent Sample Collected: January 1997

Parameter	Units (Detection Limit)	Average Value	District Percentile	Florida Percentile
Chlorophyll a	ug/l (1)	5.7	47	24
Total Phosphorus	mg/l as P (0.01)	0.061	89	46
Total Nitrogen	mg/l as N (0.06)	0.92	34	31
Transparency (Secchi depth)	meters	0.92	30	61
Florida Trophic State Index		50	73	35
Specific Conductance	S/cm at 25C (1)	66	<5	10
pH	standard units (0.1)	7.5	61	53
Color	PtCo units (1)	45	76	35
Turbidity	NTU (1)	5.6	76	53
Total Alkalinity	mg/l as CaCO3 (1)	22	45	41
Hardness	mg/l as CaCO3 (0.02)	26	16	
Total Suspended Solids	mg/l (0.05)	5.4	79	
Ammonia	mg/l as N (0.03)	0.030	61	
Nitrate+Nitrite	mg/l as N (0.01)	0.005	33	
Total Kjeldahl Nitrogen	mg/l as N (0.06)	0.92	40	
Orthophosphorus	mg/l as P (0.01)	0.012	68	
Chloride	mg/l (0.05)	3	<5	
Sulfate	mg/l (0.05)	3	14	
Sodium	mg/l (0.06)	3.0	<5	
Potassium	mg/l (0.07)	1.1	20	
Calcium	mg/l (0.04)	8.2	28	
Magnesium	mg/l (0.006)	1.3	12	
Iron	ug/l (0.03)	163	90	

Based upon the average FTSI of 50, water quality is considered fair. Rock Pond can be characterized as a colored, soft water, eutrophic lake, with high concentrations of total phosphorus. The chemical type of water (predominant ionic composition) is calcium bicarbonate.

Plots and Trends: No or insufficient data available for plotting or trend detection. Shown is a diagram of the relative ionic composition of the lake water.

MAJOR IONS (% meq/l)

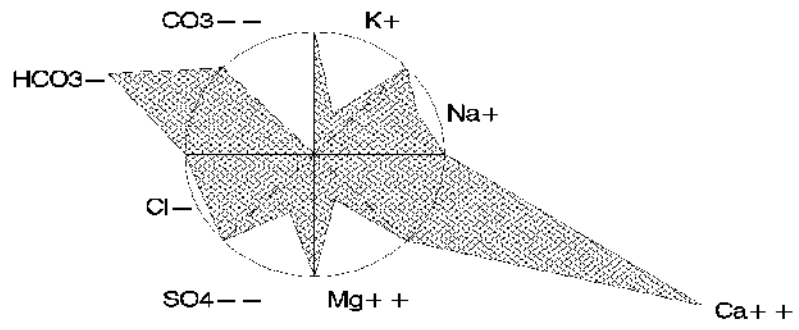

Rock Pond, Hernando County

Skinner Lake

Hernando County

USGS Quadrangle: Brooksville NW Major Land Use/Land Cover (1990)
 Section/Township/Range: 13-21S-18E within 500 meters of the lakeshore:
 Approx. Lake Center, Lat/Long: 283939/822754 - cropland and pastureland (60%)
 Surface Area: 75 acres - other open lands - rural (11%)
 Approx. Lake Elevation: 68 feet - freshwater marshes (8%)
 Lake Type: isolated (type 4)
 Major Basin: Upper Coastal Drainage
 Minor Basin: Chassahowitzka River
 Lake Region: Southern Brooksville Ridge

Total Number of Samples Collected: 13 Most Recent Sample Collected: September 1995

Parameter	Units (Detection Limit)	Average Value	District Percentile	Florida Percentile
Chlorophyll a	ug/l (1)	2.4	17	10
Total Phosphorus	mg/l as P (0.01)	0.024	71	14
Total Nitrogen	mg/l as N (0.06)	0.93	35	31
Transparency (Secchi depth)	meters	1.25	42	71
Florida Trophic State Index		31	29	6
Specific Conductance	S/cm at 25C (1)	192	56	51
pH	standard units (0.1)	8.3	87	78
Color	PtCo units (1)	10	34	10
Turbidity	NTU (1)	1.1	32	7
Total Alkalinity	mg/l as CaCO3 (1)	72	93	73
Hardness	mg/l as CaCO3 (0.02)	85	84	
Total Suspended Solids	mg/l (0.05)	1.1	31	
Ammonia	mg/l as N (0.03)	0.021	60	
Nitrate+Nitrite	mg/l as N (0.01)	0.009	33	
Total Kjeldahl Nitrogen	mg/l as N (0.06)	0.92	40	
Orthophosphorus	mg/l as P (0.01)	0.007	56	
Chloride	mg/l (0.05)	13	27	
Sulfate	mg/l (0.05)	4	17	
Sodium	mg/l (0.06)	11.4	65	
Potassium	mg/l (0.07)	0.6	13	
Calcium	mg/l (0.04)	29.0	91	
Magnesium	mg/l (0.006)	3.1	47	
Iron	ug/l (0.03)	29	36	

Based upon the average FTSI of 31, water quality is considered good. Skinner Lake can be characterized as a clear (color<=10 color units), medium hard water, oligotrophic lake. The chemical type of water (predominant ionic composition) is calcium bicarbonate (6 samples) or calcium chloride (seven samples).

Also of note:

- The measured pH was high.

Plots and Trends: No or insufficient data available for plotting or trend detection. Shown is a diagram of the relative ionic composition of the lake water.

MAJOR IONS (% meq/l)

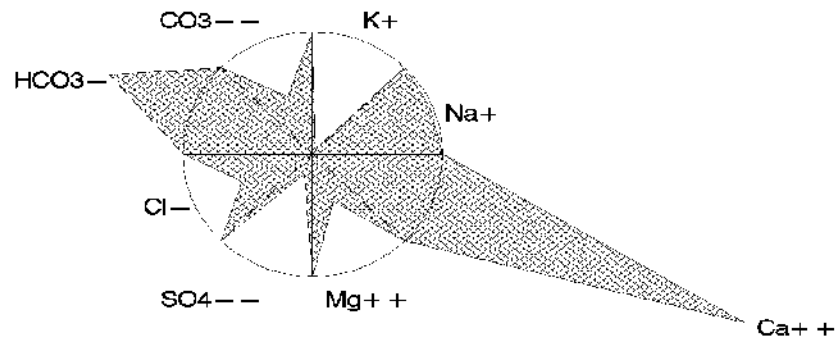

Skinner Lake, Hernando County

Sparkman Lake Hernando County

USGS Quadrangle:	Spring Lake	Major Land Use/Land Cover (1990)
Section/Township/Range:	24-23S-19E	within 500 meters of the lakeshore:
Approx. Lake Center, Lat/Long:	282754/822151	- hardwood - conifer mixed (31%)
Surface Area:	26 acres	- stream and lake swamps (27%)
Approx. Lake Elevation:	92 feet	- low density residential (19%)
Average Depth: 3.6 feet		
Observed Maximum Depth: 8 feet (reference elevation 89.4 feet)		
Lake Type: inflow and outflow (type 3)		
Major Basin: Upper Coastal Drainage		
Minor Basin: Crews Lake Outlet		
Lake Region: Southern Brooksville Ridge		

Total Number of Samples Collected: 2 Most Recent Sample Collected: January 1996

Parameter	Units (Detection Limit)	Average Value	District Percentile	Florida Percentile
Chlorophyll a	ug/l (1)	45.9	93	80
Total Phosphorus	mg/l as P (0.01)	0.071	91	51
Total Nitrogen	mg/l as N (0.06)	2.03	85	82
Transparency (Secchi depth)	meters	0.40	<5	5
Florida Trophic State Index		44	60	22
Specific Conductance	S/cm at 25C (1)	82	8	16
pH	standard units (0.1)	7.0	34	30
Color	PtCo units (1)	250	>95	>95
Turbidity	NTU (1)	6.9	81	60
Total Alkalinity	mg/l as CaCO3 (1)	18	40	36
Hardness	mg/l as CaCO3 (0.02)	31	23	
Total Suspended Solids	mg/l (0.05)	4.0	73	
Ammonia	mg/l as N (0.03)	0.038	67	
Nitrate+Nitrite	mg/l as N (0.01)	0.017	46	
Total Kjeldahl Nitrogen	mg/l as N (0.06)	2.01	90	
Orthophosphorus	mg/l as P (0.01)	0.021	86	
Chloride	mg/l (0.05)	12	23	
Sulfate	mg/l (0.05)	3	14	
Sodium	mg/l (0.06)	5.2	14	
Potassium	mg/l (0.07)	1.9	32	
Calcium	mg/l (0.04)	8.7	32	
Magnesium	mg/l (0.006)	2.3	33	
Iron	ug/l (0.03)	284	95	

Based upon the average FTSI of 44, water quality is considered fair. Sparkman Lake can be characterized as a highly colored, soft water, hypereutrophic lake, with high concentrations of total phosphorus and high concentrations of total nitrogen. The chemical type of water (predominant ionic composition) is calcium chloride.

Plots and Trends: Shown are a plot of lake surface elevation and a diagram of the relative ionic composition of the lake water.

MONTHLY AVERAGE SURFACE ELEVATION

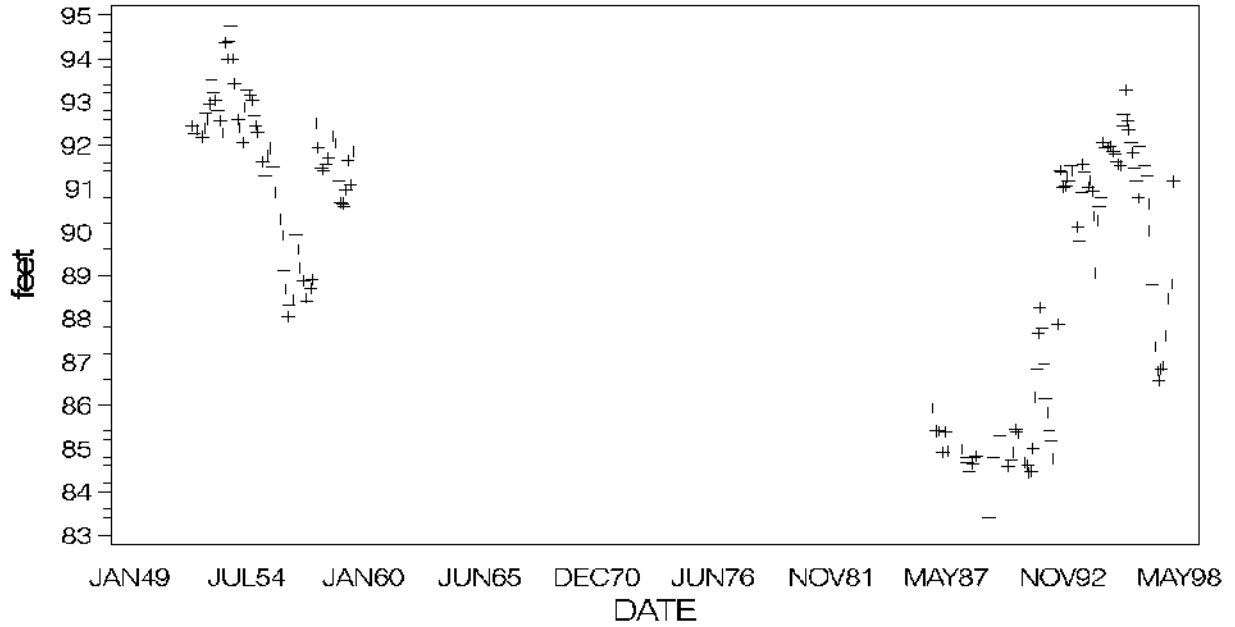

MAJOR IONS (% meq/l)

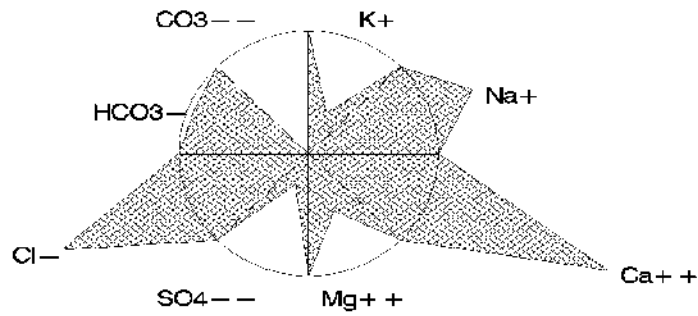

Spring Lake Hernando County

USGS Quadrangle:	Spring Lake	Major Land Use/Land Cover (1990)
Section/Township/Range:	15-23S-20E	within 500 meters of the lakeshore:
Approx. Lake Center, Lat/Long:	282935/821740	- other open lands - rural (43%)
Surface Area:	58 acres	- cropland and pastureland (26%)
Approx. Lake Elevation:	184 feet	- upland coniferous forests (10%)
Average Depth: 22.4 feet		
Observed Maximum Depth: 39 feet		
(reference elevation 180.8 feet)		
Lake Type: isolated (type 4)		
Major Basin: Withlacoochee River		
Minor Basin: Withlacoochee River		
Lake Region: Southern Brooksville Ridge		

Total Number of Samples Collected: 13 Most Recent Sample Collected: September 1995

Parameter	Units (Detection Limit)	Average Value	District Percentile	Florida Percentile
Chlorophyll a	ug/l (1)	3.2	27	13
Total Phosphorus	mg/l as P (0.01)	0.017	58	9
Total Nitrogen	mg/l as N (0.06)	0.71	18	21
Transparency (Secchi depth)	meters	3.13	86	>95
Florida Trophic State Index		30	28	5
Specific Conductance	S/cm at 25C (1)	178	48	48
pH	standard units (0.1)	7.6	64	57
Color	PtCo units (1)	7	18	7
Turbidity	NTU (1)	0.6	28	<5
Total Alkalinity	mg/l as CaCO3 (1)	32	62	51
Hardness	mg/l as CaCO3 (0.02)	67	70	
Total Suspended Solids	mg/l (0.05)	0.8	21	
Ammonia	mg/l as N (0.03)	0.041	69	
Nitrate+Nitrite	mg/l as N (0.01)	0.043	67	
Total Kjeldahl Nitrogen	mg/l as N (0.06)	0.67	22	
Orthophosphorus	mg/l as P (0.01)	0.005	56	
Chloride	mg/l (0.05)	21	61	
Sulfate	mg/l (0.05)	10	37	
Sodium	mg/l (0.06)	8.3	46	
Potassium	mg/l (0.07)	8.5	87	
Calcium	mg/l (0.04)	12.2	50	
Magnesium	mg/l (0.006)	8.9	85	
Iron	ug/l (0.03)	14	8	

Based upon the average FTSI of 30, water quality is considered good. Spring Lake can be characterized as a clear (color<=10 color units), medium hard water, oligo-mesotrophic lake, with low concentrations of total nitrogen. The chemical type of water (predominant ionic composition) is calcium chloride.

Plots and Trends: Shown are a plot of lake surface elevation and a diagram of the relative ionic composition of the lake water.

MONTHLY AVERAGE SURFACE ELEVATION

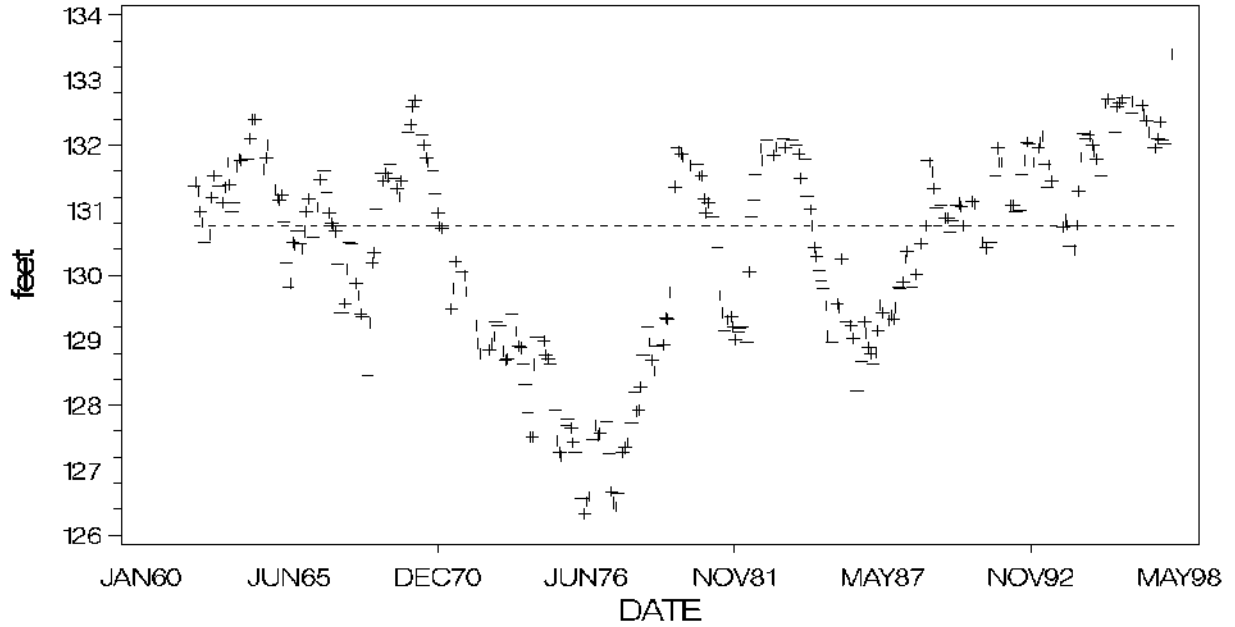

MAJOR IONS (% meq/l)

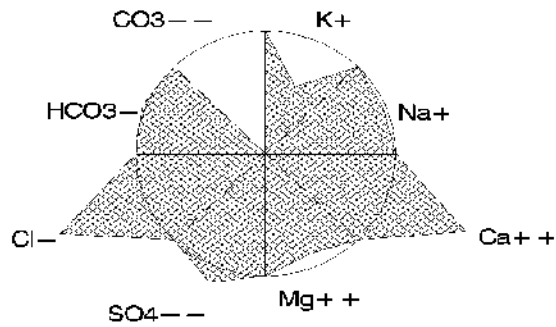

Spring Lake, Hernando County

Tank Lake

Hernando County

USGS Quadrangle: Brooksville Major Land Use/Land Cover (1990)
 Section/Township/Range: 28-21S-19E within 500 meters of the lakeshore:
 Approx. Lake Center, Lat/Long: 283720/822443 - hardwood - conifer mixed (71%)
 Surface Area: 18 acres - stream and lake swamps (12%)
 Approx. Lake Elevation: 77 feet - freshwater marshes (11%)
 Lake Type: outflow (type 2)
 Major Basin: Withlacoochee River
 Minor Basin: Withlacoochee River
 Lake Region: Southern Brooksville Ridge

Total Number of Samples Collected: 13 Most Recent Sample Collected: September 1995

Parameter	Units (Detection Limit)	Average Value	District Percentile	Florida Percentile
Chlorophyll a	ug/l (1)	4.1	37	17
Total Phosphorus	mg/l as P (0.01)	0.021	66	11
Total Nitrogen	mg/l as N (0.06)	1.15	52	38
Transparency (Secchi depth)	meters	1.43	47	75
Florida Trophic State Index		38	50	13
Specific Conductance	S/cm at 25C (1)	58	<5	8
pH	standard units (0.1)	6.6	18	20
Color	PtCo units (1)	47	77	37
Turbidity	NTU (1)	1.3	36	10
Total Alkalinity	mg/l as CaCO3 (1)	11	29	27
Hardness	mg/l as CaCO3 (0.02)	22	11	
Total Suspended Solids	mg/l (0.05)	1.5	39	
Ammonia	mg/l as N (0.03)	0.026	60	
Nitrate+Nitrite	mg/l as N (0.01)	0.016	45	
Total Kjeldahl Nitrogen	mg/l as N (0.06)	1.13	58	
Orthophosphorus	mg/l as P (0.01)	0.005	56	
Chloride	mg/l (0.05)	6	5	
Sulfate	mg/l (0.05)	1	6	
Sodium	mg/l (0.06)	2.8	<5	
Potassium	mg/l (0.07)	0.2	<5	
Calcium	mg/l (0.04)	7.0	24	
Magnesium	mg/l (0.006)	1.0	6	
Iron	ug/l (0.03)	56	66	

Based upon the average FTSI of 38, water quality is considered good. Tank Lake can be characterized as a colored, soft water, oligo-mesotrophic lake. The chemical type of water (predominant ionic composition) is calcium chloride (6 samples) or calcium bicarbonate (7 samples).

Plots and Trends: No or insufficient data available for plotting or trend detection. Shown is a diagram of the relative ionic composition of the lake water.

MAJOR IONS (% meq/l)

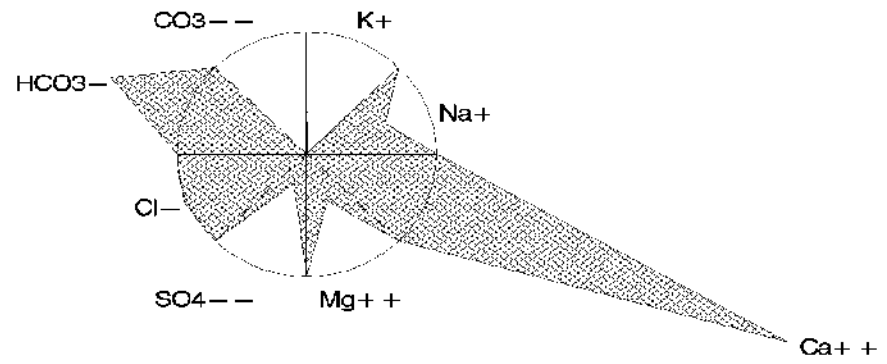

Tank Lake, Hernando County

Tooke Lake Hernando County

USGS Quadrangle: Weeki Wachee Springs
 Section/Township/Range: 13-22S-17E
 Approx. Lake Center, Lat/Long: 283411/823309
 Surface Area: 236 acres
 Approx. Lake Elevation: 19 feet
 Lake Type: isolated (type 4)
 Major Basin: Upper Coastal Drainage
 Minor Basin: Weekiwachee River
 Lake Region: Weeki Wachee Hills

Major Land Use/Land Cover (1990)
 within 500 meters of the lakeshore:
 - longleaf pine - xeric pine (40%)
 - freshwater marshes (22%)
 - high density residential (13%)

Total Number of Samples Collected: 2 Most Recent Sample Collected: January 1996

Parameter	Units (Detection Limit)	Average Value	District Percentile	Florida Percentile
Chlorophyll a	ug/l (1)	3.3	28	14
Total Phosphorus	mg/l as P (0.01)	0.008	31	<5
Total Nitrogen	mg/l as N (0.06)	0.96	37	32
Transparency (Secchi depth)	meters	-	-	-
Florida Trophic State Index		29	25	<5
Specific Conductance	S/cm at 25C (1)	93	12	20
pH	standard units (0.1)	7.1	38	35
Color	PtCo units (1)	8	24	8
Turbidity	NTU (1)	0.9	28	<5
Total Alkalinity	mg/l as CaCO3 (1)	5	13	13
Hardness	mg/l as CaCO3 (0.02)	27	18	
Total Suspended Solids	mg/l (0.05)	0.7	18	
Ammonia	mg/l as N (0.03)	0.107	88	
Nitrate+Nitrite	mg/l as N (0.01)	0.016	45	
Total Kjeldahl Nitrogen	mg/l as N (0.06)	0.94	42	
Orthophosphorus	mg/l as P (0.01)	0.005	56	
Chloride	mg/l (0.05)	9	12	
Sulfate	mg/l (0.05)	22	65	
Sodium	mg/l (0.06)	5.4	16	
Potassium	mg/l (0.07)	0.5	11	
Calcium	mg/l (0.04)	9.2	35	
Magnesium	mg/l (0.006)	1.0	6	
Iron	ug/l (0.03)	22	25	

Based upon the average FTSI of 29, water quality is considered good. Tooke Lake can be characterized as a clear (color<=10 color units), soft water, oligo-mesotrophic lake, with low concentrations of total phosphorus. The chemical type of water (predominant ionic composition) is calcium sulfate.

Plots and Trends: No or insufficient data available for plotting or trend detection. Shown is a diagram of the relative ionic composition of the lake water.

MAJOR IONS (% meq/l)

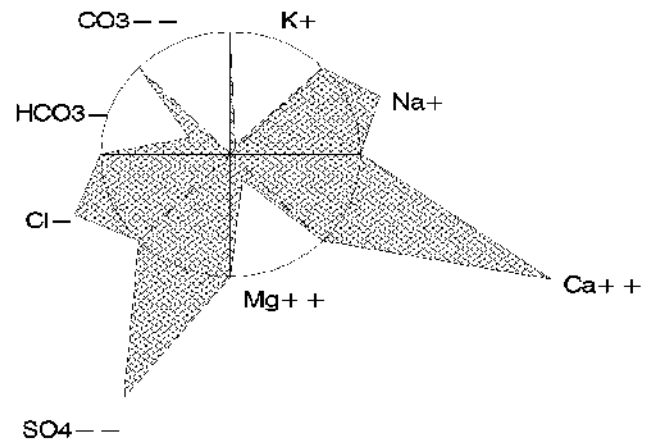

Tooke Lake, Hernando County

Unnamed Lake Hernando County

USGS Quadrangle: Weeki Wachee Springs Major Land Use/Land Cover (1990)
 Section/Township/Range: 30-22S-18E within 500 meters of the lakeshore:
 Approx. Lake Center, Lat/Long: 283207/823232 - longleaf pine - xeric pine (72%)
 Surface Area: 4 acres - open land (16%)
 Approx. Lake Elevation: 20 feet - freshwater marshes (4%)
 Lake Type: isolated (type 4)
 Major Basin: Upper Coastal Drainage
 Minor Basin: Weekiwachee River
 Lake Region: Weeki Wachee Hills

Total Number of Samples Collected: 15 Most Recent Sample Collected: January 1996

Parameter	Units (Detection Limit)	Average Value	District Percentile	Florida Percentile
Chlorophyll a	ug/l (1)	1.5	5	5
Total Phosphorus	mg/l as P (0.01)	0.010	33	5
Total Nitrogen	mg/l as N (0.06)	0.99	40	33
Transparency (Secchi depth)	meters	1.50	49	76
Florida Trophic State Index		23	10	<5
Specific Conductance	S/cm at 25C (1)	133	26	36
pH	standard units (0.1)	8.4	90	80
Color	PtCo units (1)	8	24	8
Turbidity	NTU (1)	2.7	60	29
Total Alkalinity	mg/l as CaCO3 (1)	55	83	65
Hardness	mg/l as CaCO3 (0.02)	63	65	
Total Suspended Solids	mg/l (0.05)	1.4	37	
Ammonia	mg/l as N (0.03)	0.021	60	
Nitrate+Nitrite	mg/l as N (0.01)	0.014	42	
Total Kjeldahl Nitrogen	mg/l as N (0.06)	0.98	46	
Orthophosphorus	mg/l as P (0.01)	0.005	56	
Chloride	mg/l (0.05)	5	<5	
Sulfate	mg/l (0.05)	2	10	
Sodium	mg/l (0.06)	3.1	<5	
Potassium	mg/l (0.07)	0.0	<5	
Calcium	mg/l (0.04)	23.7	85	
Magnesium	mg/l (0.006)	1.0	6	
Iron	ug/l (0.03)	22	25	

Based upon the average FTSI of 23, water quality is considered good. Unnamed Lake can be characterized as a clear (color<=10 color units), medium hard water, oligotrophic lake. The chemical type of water (predominant ionic composition) is calcium bicarbonate.

Also of note:

- The measured pH was high.

Plots and Trends: No or insufficient data available for plotting or trend detection. Shown is a diagram of the relative ionic composition of the lake water.

MAJOR IONS (% meq/l)

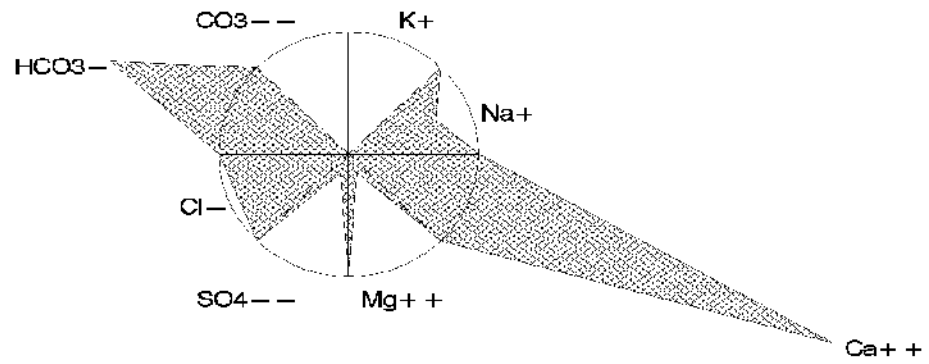

Unnamed Lake, Hernando County

Lake Adelaide Highlands County

USGS Quadrangle: Frostproof Major Land Use/Land Cover (1990)
 Section/Township/Range: 5-33S-28E within 500 meters of the lakeshore:
 Approx. Lake Center, Lat/Long: 273826/813156 - tree crops, typically citrus (30%)
 Surface Area: 96 acres - low density residential (24%)
 Approx. Lake Elevation: 107 feet - other open lands - rural (19%)
 Average Depth: 9.5 feet
 Observed Maximum Depth: 16 feet
 (reference elevation 106 feet)
 Lake Type: inflow and outflow (type 3)
 Major Basin: Kissimmee Ridge
 Minor Basin: Livingston Creek
 Lake Region: Lake Wales Ridge Transition
 Public Access: yes

Total Number of Samples Collected: 2 Most Recent Sample Collected: January 1995

Parameter	Units (Detection Limit)	Average Value	District Percentile	Florida Percentile
Chlorophyll a	ug/l (1)	4.5	41	18
Total Phosphorus	mg/l as P (0.01)	0.011	38	6
Total Nitrogen	mg/l as N (0.06)	0.47	<5	9
Transparency (Secchi depth)	meters	2.10	67	87
Florida Trophic State Index		35	41	9
Specific Conductance	S/cm at 25C (1)	73	5	13
pH	standard units (0.1)	5.9	<5	7
Color	PtCo units (1)	30	67	23
Turbidity	NTU (1)	2.2	54	23
Total Alkalinity	mg/l as CaCO3 (1)	3	7	8
Hardness	mg/l as CaCO3 (0.02)	15	5	
Total Suspended Solids	mg/l (0.05)	3.3	66	
Ammonia	mg/l as N (0.03)	0.015	60	
Nitrate+Nitrite	mg/l as N (0.01)	0.005	33	
Total Kjeldahl Nitrogen	mg/l as N (0.06)	0.47	8	
Orthophosphorus	mg/l as P (0.01)	0.014	76	
Chloride	mg/l (0.05)	10	15	
Sulfate	mg/l (0.05)	12	41	
Sodium	mg/l (0.06)	5.7	19	
Potassium	mg/l (0.07)	1.9	32	
Calcium	mg/l (0.04)	2.6	<5	
Magnesium	mg/l (0.006)	2.0	25	
Iron	ug/l (0.03)	30	38	

Based upon the average FTSI of 35, water quality is considered good. Lake Adelaide can be characterized as a moderately colored, soft water, mesotrophic lake, with very low concentrations of total nitrogen. The chemical type of water (predominant ionic composition) is sodium chloride.

Also of note:

- the measured pH was low

Plots and Trends: The lake surface elevation has risen in recent years. Also shown is a diagram of the relative ionic composition of the lake water.

MONTHLY AVERAGE SURFACE ELEVATION

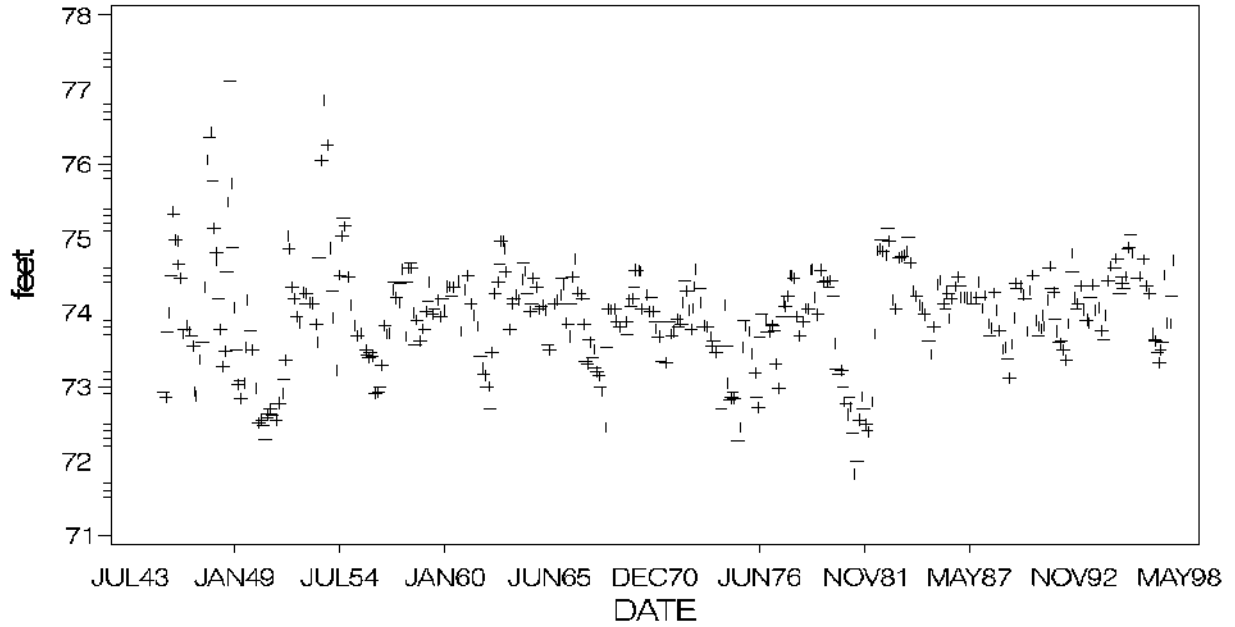

MAJOR IONS (% meq/l)

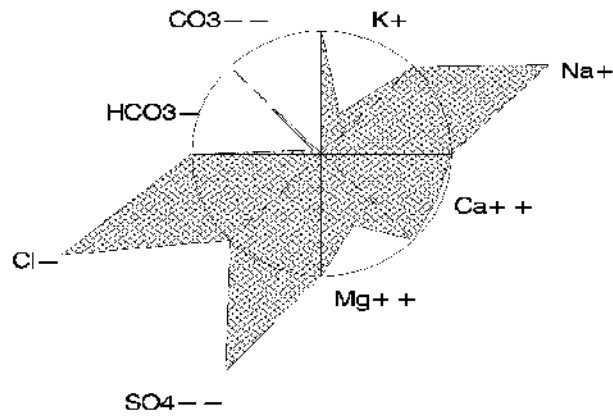

Lake Angelo

Highlands County

USGS Quadrangle: Lake Arbuckle SW Major Land Use/Land Cover (1990)
 Section/Township/Range: 25-33S-28E within 500 meters of the lakeshore:
 Approx. Lake Center, Lat/Long: 273510/812800 - tree crops, typically citrus (54%)
 Surface Area: 60 acres - cropland and pastureland (22%)
 Approx. Lake Elevation: 100 feet - medium density residential (11%)
 Lake Type: isolated (type 4)
 Major Basin: Kissimmee Ridge
 Minor Basin: Carter Creek
 Lake Region: Southern Lake Wales Ridge

Total Number of Samples Collected: 2 Most Recent Sample Collected: January 1995

Parameter	Units (Detection Limit)	Average Value	District Percentile	Florida Percentile
Chlorophyll a	ug/l (1)	7.3	54	31
Total Phosphorus	mg/l as P (0.01)	0.016	56	8
Total Nitrogen	mg/l as N (0.06)	1.00	41	33
Transparency (Secchi depth)	meters	2.85	81	95
Florida Trophic State Index		37	45	11
Specific Conductance	S/cm at 25C (1)	232	72	57
pH	standard units (0.1)	7.6	64	57
Color	PtCo units (1)	10	34	10
Turbidity	NTU (1)	1.0	29	5
Total Alkalinity	mg/l as CaCO3 (1)	51	80	63
Hardness	mg/l as CaCO3 (0.02)	82	82	
Total Suspended Solids	mg/l (0.05)	1.3	35	
Ammonia	mg/l as N (0.03)	0.015	60	
Nitrate+Nitrite	mg/l as N (0.01)	0.194	87	
Total Kjeldahl Nitrogen	mg/l as N (0.06)	0.81	32	
Orthophosphorus	mg/l as P (0.01)	0.014	76	
Chloride	mg/l (0.05)	16	37	
Sulfate	mg/l (0.05)	31	79	
Sodium	mg/l (0.06)	7.8	42	
Potassium	mg/l (0.07)	7.4	83	
Calcium	mg/l (0.04)	18.0	69	
Magnesium	mg/l (0.006)	8.9	85	
Iron	ug/l (0.03)	16	11	

Based upon the average FTSI of 37, water quality is considered good. Lake Angelo can be characterized as a clear (color<=10 PtCo units), medium hard water, mesotrophic lake. The chemical type of water (predominant ionic composition) is calcium sulfate.

Plots and Trends: There are few or no historical water quality data for Lake Angelo. No trend is evident in the lake surface elevation data for the short period of record. Also shown is a diagram of the relative ionic composition of the lake water.

MONTHLY AVERAGE SURFACE ELEVATION

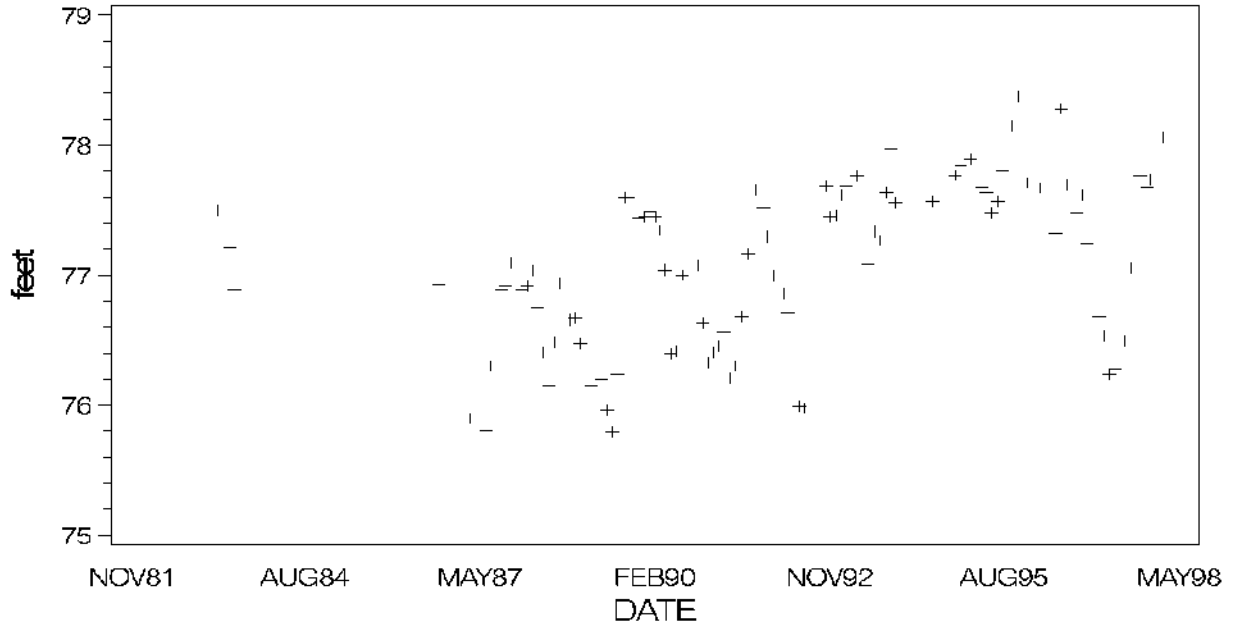

MAJOR IONS (% meq/l)

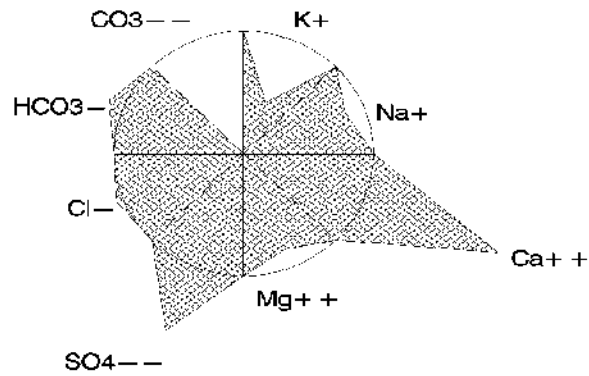

Lake Angelo, Highlands County

Lake Anoka

Highlands County

USGS Quadrangle: Avon Park Major Land Use/Land Cover (1990)
 Section/Township/Range: 27-33S-28E within 500 meters of the lakeshore:
 Approx. Lake Center, Lat/Long: 273448/813044 - tree crops, typically citrus (29%)
 Surface Area: 50 acres - medium density residential (24%)
 Approx. Lake Elevation: 124 feet - other open lands - rural (18%)
 Lake Type: inflow (type 1)
 Major Basin: Kissimmee Ridge
 Minor Basin: Carter Creek
 Lake Region: Southern Lake Wales Ridge

Total Number of Samples Collected: 2 Most Recent Sample Collected: January 1996

Parameter	Units (Detection Limit)	Average Value	District Percentile	Florida Percentile
Chlorophyll a	ug/l (1)	2.6	19	11
Total Phosphorus	mg/l as P (0.01)	0.005	31	<5
Total Nitrogen	mg/l as N (0.06)	1.05	45	35
Transparency (Secchi depth)	meters	4.00	93	>95
Florida Trophic State Index		27	20	<5
Specific Conductance	S/cm at 25C (1)	1284	>95	>95
pH	standard units (0.1)	7.7	69	60
Color	PtCo units (1)	5	9	5
Turbidity	NTU (1)	1.1	32	7
Total Alkalinity	mg/l as CaCO3 (1)	26	52	45
Hardness	mg/l as CaCO3 (0.02)	44	43	
Total Suspended Solids	mg/l (0.05)	1.0	28	
Ammonia	mg/l as N (0.03)	0.060	80	
Nitrate+Nitrite	mg/l as N (0.01)	0.467	91	
Total Kjeldahl Nitrogen	mg/l as N (0.06)	0.58	14	
Orthophosphorus	mg/l as P (0.01)	0.005	56	
Chloride	mg/l (0.05)	8	9	
Sulfate	mg/l (0.05)	19	58	
Sodium	mg/l (0.06)	3.3	<5	
Potassium	mg/l (0.07)	3.8	52	
Calcium	mg/l (0.04)	12.5	51	
Magnesium	mg/l (0.006)	3.0	45	
Iron	ug/l (0.03)	48	60	

Based upon the average FTSI of 27, water quality is considered good. Lake Anoka can be characterized as a clear (color<=10 PtCo units), soft water, oligotrophic lake, with low concentrations of total phosphorus. The chemical type of water (predominant ionic composition) is calcium sulfate.

Also of note:

- Melaleuca was observed on the lake shore.

Plots and Trends: There are few or no historical water quality data for Lake Anoka. No trend is evident in the lake surface elevation data for the short period of record. Also shown is a diagram of the relative ionic composition of the lake water.

MONTHLY AVERAGE SURFACE ELEVATION

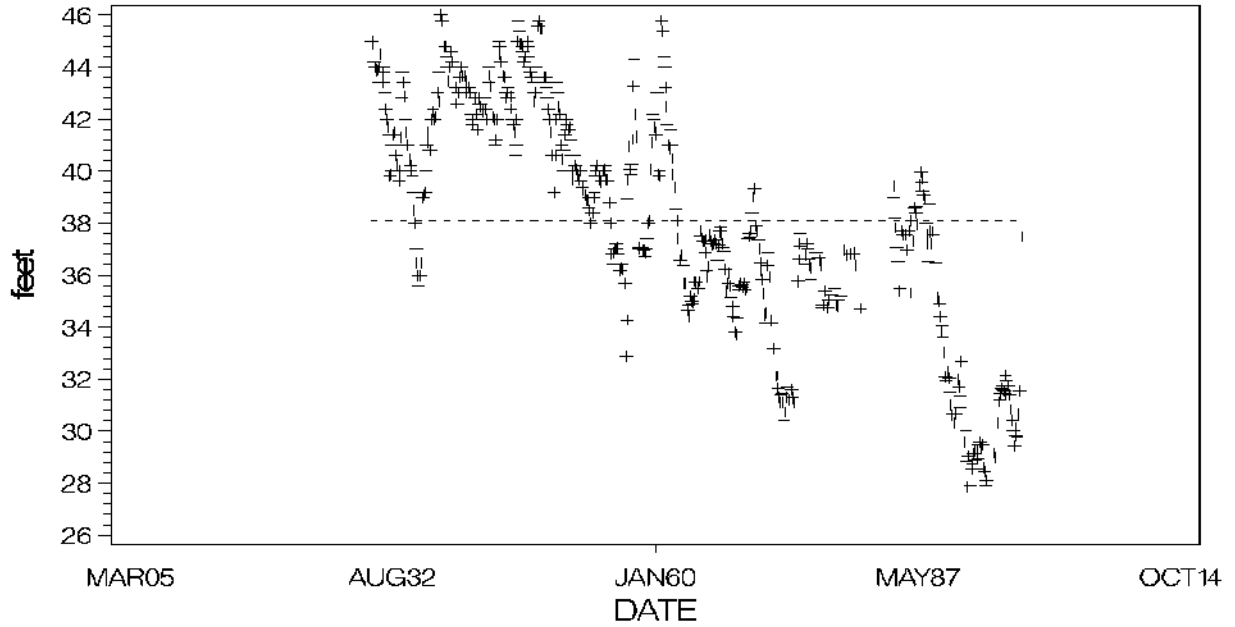

MAJOR IONS (% meq/l)

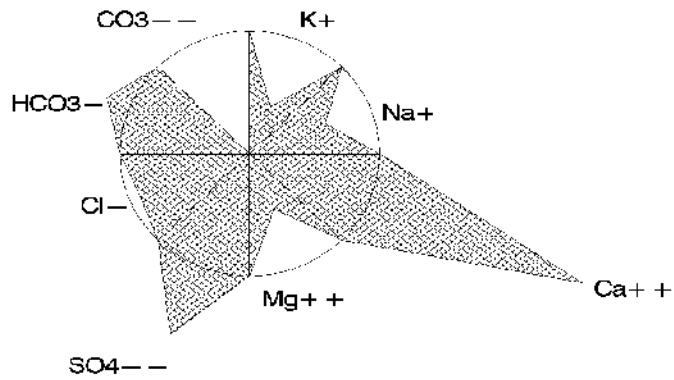

Lake Apthorpe Highlands County

USGS Quadrangle: Lake Placid
 Section/Township/Range: 18-36S-30E
 Approx. Lake Center, Lat/Long: 272039/812152
 Surface Area: 219 acres
 Approx. Lake Elevation: 72 feet
 Average Depth: 13.3 feet
 Observed Maximum Depth: 33 feet
 (reference elevation 69.4 feet)
 Lake Type: inflow and outflow (type 3)
 Major Basin: Kissimmee Ridge
 Minor Basin: Grassy Creek
 Lake Region: Lake Wales Ridge Transition
 Public Access: yes

Major Land Use/Land Cover (1990)
 within 500 meters of the lakeshore:
 - tree crops, typically citrus (46%)
 - stream and lake swamps (29%)
 - wet prairies (7%)

Total Number of Samples Collected: 2 Most Recent Sample Collected: January 1995

Parameter	Units (Detection Limit)	Average Value	District Percentile	Florida Percentile
Chlorophyll a	ug/l (1)	7.2	54	31
Total Phosphorus	mg/l as P (0.01)	0.008	31	<5
Total Nitrogen	mg/l as N (0.06)	1.63	73	67
Transparency (Secchi depth)	meters	2.50	75	92
Florida Trophic State Index		35	40	9
Specific Conductance	S/cm at 25C (1)	186	54	50
pH	standard units (0.1)	7.1	38	35
Color	PtCo units (1)	20	55	17
Turbidity	NTU (1)	2.5	58	26
Total Alkalinity	mg/l as CaCO3 (1)	12	31	29
Hardness	mg/l as CaCO3 (0.02)	48	50	
Total Suspended Solids	mg/l (0.05)	2.0	51	
Ammonia	mg/l as N (0.03)	0.030	61	
Nitrate+Nitrite	mg/l as N (0.01)	0.285	89	
Total Kjeldahl Nitrogen	mg/l as N (0.06)	1.35	71	
Orthophosphorus	mg/l as P (0.01)	0.010	59	
Chloride	mg/l (0.05)	23	69	
Sulfate	mg/l (0.05)	33	82	
Sodium	mg/l (0.06)	10.5	62	
Potassium	mg/l (0.07)	6.4	77	
Calcium	mg/l (0.04)	8.2	28	
Magnesium	mg/l (0.006)	6.7	80	
Iron	ug/l (0.03)	18	15	

Based upon the average FTSI of 35, water quality is considered good. Lake Apthorpe can be characterized as a moderately colored, soft water, meso-eutrophic lake, with low concentrations of total phosphorus. The chemical type of water (predominant ionic composition) is sodium sulfate.

Plots and Trends: No or insufficient data for plotting or trend detection. Shown is a diagram of the relative ionic composition of the lake water.

MAJOR IONS (% meq/l)

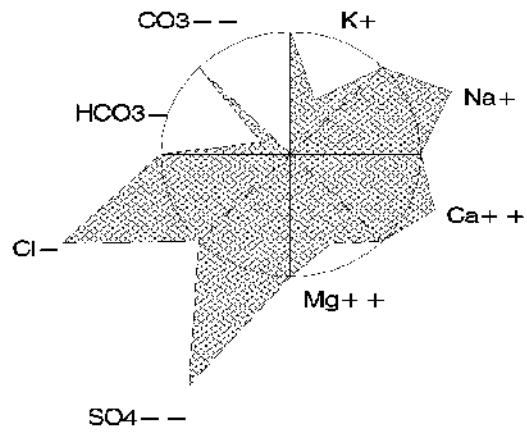

August Lake Highlands County

USGS Quadrangle: Lake June-in-Winter
 Section/Township/Range: 10-37S-29E
 Approx. Lake Center, Lat/Long: 271628/812448
 Surface Area: 20 acres
 Approx. Lake Elevation: 100 feet
 Lake Type: outflow (type 2)
 Major Basin: Kissimmee Ridge
 Minor Basin: Lake Francis Outlet
 Lake Region: Lake Wales Ridge Transition

Major Land Use/Land Cover (1990)
 within 500 meters of the lakeshore:
 - low density residential (76%)
 - medium density residential (23%)
 - stream and lake swamps (1%)

Total Number of Samples Collected: 2 Most Recent Sample Collected: January 1996

Parameter	Units (Detection Limit)	Average Value	District Percentile	Florida Percentile
Chlorophyll a	ug/l (1)	1.8	10	7
Total Phosphorus	mg/l as P (0.01)	0.106	95	69
Total Nitrogen	mg/l as N (0.06)	0.47	<5	9
Transparency (Secchi depth)	meters	1.28	44	72
Florida Trophic State Index		26	19	<5
Specific Conductance	S/cm at 25C (1)	83	9	16
pH	standard units (0.1)	6.3	10	13
Color	PtCo units (1)	175	>95	94
Turbidity	NTU (1)	2.9	62	31
Total Alkalinity	mg/l as CaCO3 (1)	11	29	27
Hardness	mg/l as CaCO3 (0.02)	21	10	
Total Suspended Solids	mg/l (0.05)	0.5	11	
Ammonia	mg/l as N (0.03)	0.121	91	
Nitrate+Nitrite	mg/l as N (0.01)	0.120	83	
Total Kjeldahl Nitrogen	mg/l as N (0.06)	0.34	<5	
Orthophosphorus	mg/l as P (0.01)	0.074	>95	
Chloride	mg/l (0.05)	12	23	
Sulfate	mg/l (0.05)	7	27	
Sodium	mg/l (0.06)	6.7	30	
Potassium	mg/l (0.07)	2.0	34	
Calcium	mg/l (0.04)	5.8	18	
Magnesium	mg/l (0.006)	1.6	18	
Iron	ug/l (0.03)	104	83	

Based upon the average FTSI of 26, water quality is considered fair. August Lake can be characterized as a highly colored, soft water, meso-eutrophic lake, with high concentrations of total phosphorus and very low concentrations of total nitrogen. The chemical type of water (predominant ionic composition) is calcium chloride (1 sample) or sodium chloride (1 sample).

Plots and Trends: No or insufficient data for plotting or trend detection. Shown is a diagram of the relative ionic composition of the lake water.

MAJOR IONS (% meq/l)

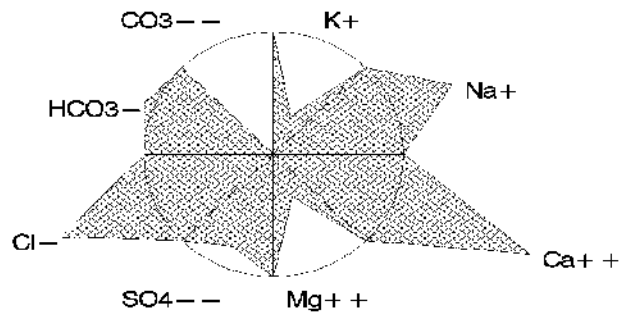

Basket Lake

Highlands County

USGS Quadrangle: Lake Arbuckle SW Major Land Use/Land Cover (1990)
 Section/Township/Range: 17-34S-29E within 500 meters of the lakeshore:
 Approx. Lake Center, Lat/Long: 273143/812636 - tree crops, typically citrus (97%)
 Surface Area: 56 acres - medium density residential (2%)
 Approx. Lake Elevation: 99 feet - herbaceous range (1%)
 Lake Type: isolated (type 4)
 Major Basin: Kissimmee Ridge
 Minor Basin: Carter Creek
 Lake Region: Southern Lake Wales Ridge

Total Number of Samples Collected: 2 Most Recent Sample Collected: February 1995

Parameter	Units (Detection Limit)	Average Value	District Percentile	Florida Percentile
Chlorophyll a	ug/l (1)	5.0	44	20
Total Phosphorus	mg/l as P (0.01)	0.008	31	<5
Total Nitrogen	mg/l as N (0.06)	3.66	>95	94
Transparency (Secchi depth)	meters	3.30	89	>95
Florida Trophic State Index		28	21	<5
Specific Conductance	S/cm at 25C (1)	405	95	76
pH	standard units (0.1)	7.0	34	30
Color	PtCo units (1)	5	9	5
Turbidity	NTU (1)	0.8	28	<5
Total Alkalinity	mg/l as CaCO3 (1)	36	67	53
Hardness	mg/l as CaCO3 (0.02)	149	>95	
Total Suspended Solids	mg/l (0.05)	1.0	28	
Ammonia	mg/l as N (0.03)	0.015	60	
Nitrate+Nitrite	mg/l as N (0.01)	2.338	>95	
Total Kjeldahl Nitrogen	mg/l as N (0.06)	1.33	70	
Orthophosphorus	mg/l as P (0.01)	0.010	59	
Chloride	mg/l (0.05)	29	83	
Sulfate	mg/l (0.05)	98	>95	
Sodium	mg/l (0.06)	9.1	53	
Potassium	mg/l (0.07)	15.5	>95	
Calcium	mg/l (0.04)	29.0	91	
Magnesium	mg/l (0.006)	18.5	>95	
Iron	ug/l (0.03)	15	10	

Based upon the average FTSI of 28, water quality is considered good. Basket Lake can be characterized as a clear (color<=10 color units), hard water, mesotrophic lake, with low concentrations of total phosphorus, high concentrations of total nitrogen and very high nitrate concentrations. The chemical type of water (predominant ionic composition) is calcium sulfate.

Plots and Trends: No or insufficient data for plotting or trend detection. Shown is a diagram of the relative ionic composition of the lake water.

MAJOR IONS (% meq/l)

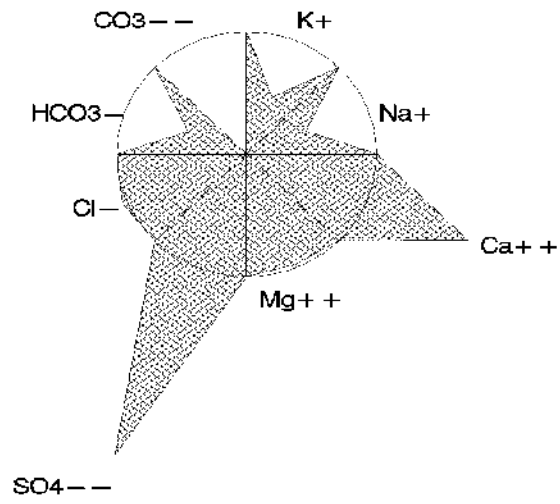

Blue Lake

Highlands County

USGS Quadrangle: Lake Placid
 Section/Township/Range: 30-36S-30E
 Approx. Lake Center, Lat/Long: 271852/812127
 Surface Area: 58 acres
 Approx. Lake Elevation: 78 feet
 Lake Type: isolated (type 4)
 Major Basin: Kissimmee Ridge
 Minor Basin: Grassy Creek
 Lake Region: Southern Lake Wales Ridge

Major Land Use/Land Cover (1990)
 within 500 meters of the lakeshore:
 - medium density residential (44%)
 - tree crops, typically citrus (41%)
 - low density residential (7%)

Total Number of Samples Collected: 2 Most Recent Sample Collected: February 1995

Parameter	Units (Detection Limit)	Average Value	District Percentile	Florida Percentile
Chlorophyll a	ug/l (1)	5.8	48	24
Total Phosphorus	mg/l as P (0.01)	0.005	31	<5
Total Nitrogen	mg/l as N (0.06)	0.97	38	32
Transparency (Secchi depth)	meters	2.80	81	94
Florida Trophic State Index		36	44	11
Specific Conductance	S/cm at 25C (1)	180	50	48
pH	standard units (0.1)	7.0	34	30
Color	PtCo units (1)	5	9	5
Turbidity	NTU (1)	1.1	32	7
Total Alkalinity	mg/l as CaCO3 (1)	22	45	41
Hardness	mg/l as CaCO3 (0.02)	44	43	
Total Suspended Solids	mg/l (0.05)	1.9	49	
Ammonia	mg/l as N (0.03)	0.062	80	
Nitrate+Nitrite	mg/l as N (0.01)	0.089	80	
Total Kjeldahl Nitrogen	mg/l as N (0.06)	0.88	37	
Orthophosphorus	mg/l as P (0.01)	0.005	56	
Chloride	mg/l (0.05)	23	69	
Sulfate	mg/l (0.05)	32	81	
Sodium	mg/l (0.06)	12.5	73	
Potassium	mg/l (0.07)	4.6	62	
Calcium	mg/l (0.04)	11.5	46	
Magnesium	mg/l (0.006)	3.8	56	
Iron	ug/l (0.03)	35	47	

Based upon the average FTSI of 36, water quality is considered good. Blue Lake can be characterized as a clear (color<=10 color units), soft water, mesotrophic lake, with low concentrations of total phosphorus and total nitrogen. The chemical type of water (predominant ionic composition) is sodium sulfate.

Plots and Trends: Lake levels have remained fairly stable over the period of record. Also shown is a diagram of the relative ionic composition of the lake water.

MONTHLY AVERAGE SURFACE ELEVATION

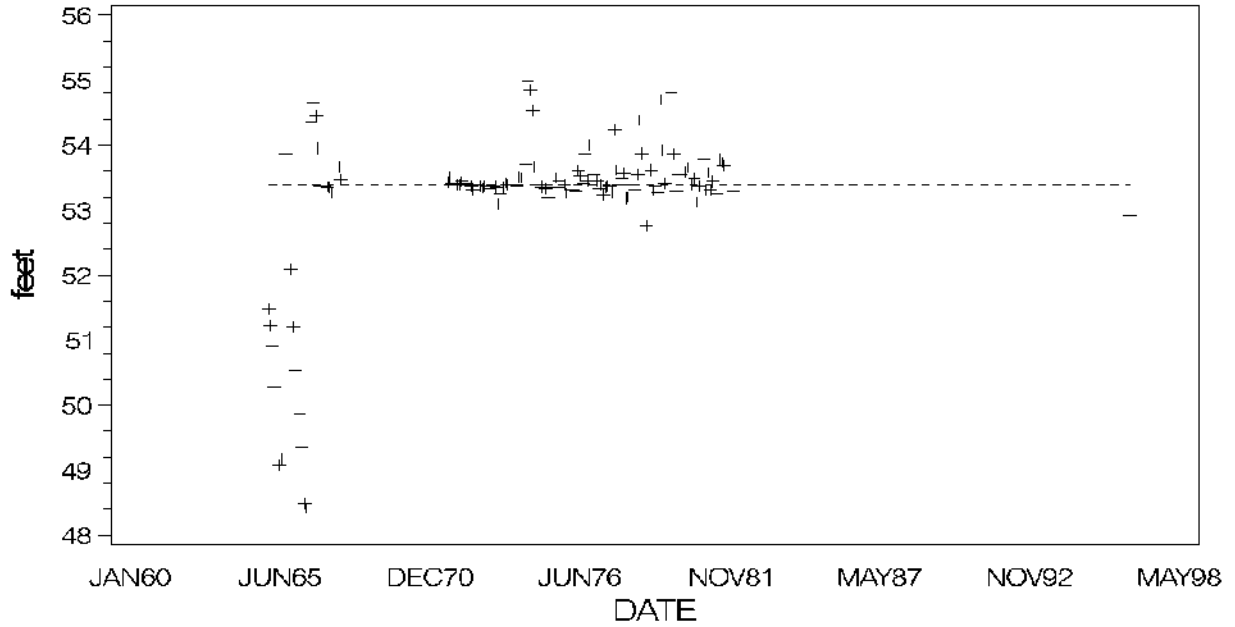

MAJOR IONS (% meq/l)

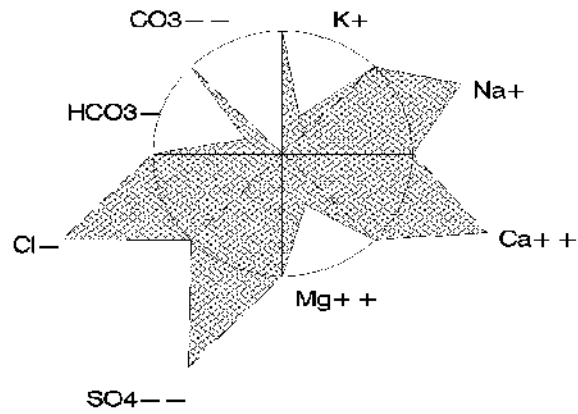

Bonnet Lake

Highlands County

USGS Quadrangle: Lake Arbuckle SW Major Land Use/Land Cover (1990)
 Section/Township/Range: 8-34S-29E within 500 meters of the lakeshore:
 Approx. Lake Center, Lat/Long: 273237/812631 - stream and lake swamps (32%)
 Surface Area: 260 acres - tree crops, typically citrus (28%)
 Approx. Lake Elevation: 91 feet - other open lands - rural (21%)
 Average Depth: 3.6 feet
 Observed Maximum Depth: 10 feet
 (reference elevation 89.2 feet)
 Lake Type: inflow and outflow (type 3)
 Major Basin: Kissimmee Ridge
 Minor Basin: Carter Creek
 Lake Region: Lake Wales Ridge Transition

Total Number of Samples Collected: 2 Most Recent Sample Collected: January 1995

Parameter	Units (Detection Limit)	Average Value	District Percentile	Florida Percentile
Chlorophyll a	ug/l (1)	27.8	84	62
Total Phosphorus	mg/l as P (0.01)	0.034	80	24
Total Nitrogen	mg/l as N (0.06)	2.68	93	90
Transparency (Secchi depth)	meters	0.73	19	43
Florida Trophic State Index		64	88	63
Specific Conductance	S/cm at 25C (1)	245	77	59
pH	standard units (0.1)	8.0	81	70
Color	PtCo units (1)	10	34	10
Turbidity	NTU (1)	10.6	89	71
Total Alkalinity	mg/l as CaCO3 (1)	30	58	49
Hardness	mg/l as CaCO3 (0.02)	85	84	
Total Suspended Solids	mg/l (0.05)	7.8	87	
Ammonia	mg/l as N (0.03)	0.034	65	
Nitrate+Nitrite	mg/l as N (0.01)	1.565	95	
Total Kjeldahl Nitrogen	mg/l as N (0.06)	1.12	56	
Orthophosphorus	mg/l as P (0.01)	0.014	76	
Chloride	mg/l (0.05)	20	56	
Sulfate	mg/l (0.05)	46	92	
Sodium	mg/l (0.06)	7.5	39	
Potassium	mg/l (0.07)	7.0	81	
Calcium	mg/l (0.04)	17.5	67	
Magnesium	mg/l (0.006)	10.1	87	
Iron	ug/l (0.03)	32	41	

Based upon the average FTSI of 64, water quality is considered fair. Bonnet Lake can be characterized as a clear (color<=10 color units), medium hard water, eutrophic lake, with high concentrations of total phosphorus, high concentrations of total nitrogen and high nitrate concentrations. The chemical type of water (predominant ionic composition) is calcium sulfate.

Also of note:

- The measured pH was high.

Plots and Trends: Lake elevations are now generally higher than those recorded in the early to mid-1980s. Also shown is a diagram of the relative ionic composition of the lake water.

MONTHLY AVERAGE SURFACE ELEVATION

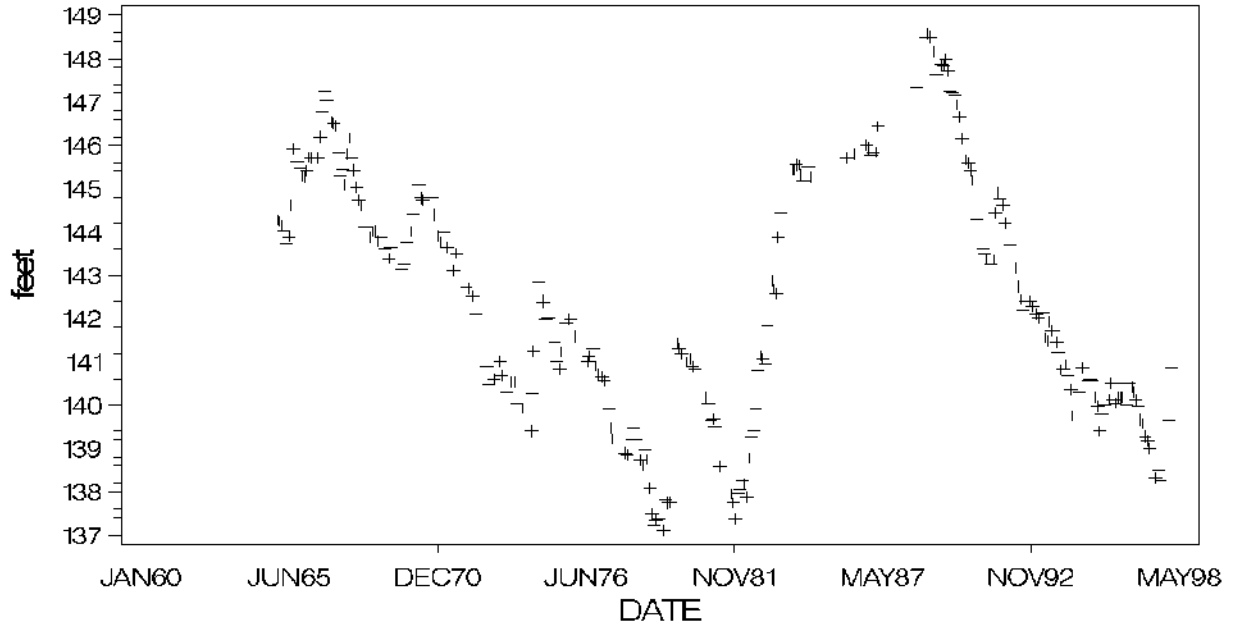

MAJOR IONS (% meq/l)

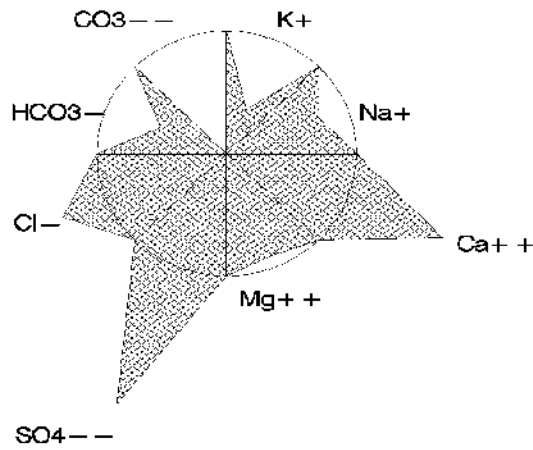

Brentwood Lake Highlands County

USGS Quadrangle:	Avon Park	Major Land Use/Land Cover (1990)
Section/Township/Range:	10-33S-28E	within 500 meters of the lakeshore:
Approx. Lake Center, Lat/Long:	273717/813040	- tree crops, typically citrus (34%)
Surface Area:	51 acres	- cropland and pastureland (16%)
Approx. Lake Elevation:	103 feet	- medium density residential (13%)
Lake Type:	outflow (type 2)	
Major Basin:	Kissimmee Ridge	
Minor Basin:	Grassy Creek	
Lake Region:	Southern Lake Wales Ridge	

Total Number of Samples Collected: 2 Most Recent Sample Collected: January 1995

Parameter	Units (Detection Limit)	Average Value	District Percentile	Florida Percentile
Chlorophyll a	ug/l (1)	2.0	13	8
Total Phosphorus	mg/l as P (0.01)	0.009	31	<5
Total Nitrogen	mg/l as N (0.06)	3.56	>95	94
Transparency (Secchi depth)	meters	3.95	93	>95
Florida Trophic State Index		23	10	<5
Specific Conductance	S/cm at 25C (1)	252	78	60
pH	standard units (0.1)	7.0	34	30
Color	PtCo units (1)	5	9	5
Turbidity	NTU (1)	0.5	28	<5
Total Alkalinity	mg/l as CaCO3 (1)	26	52	45
Hardness	mg/l as CaCO3 (0.02)	91	87	
Total Suspended Solids	mg/l (0.05)	0.9	24	
Ammonia	mg/l as N (0.03)	0.015	60	
Nitrate+Nitrite	mg/l as N (0.01)	2.585	>95	
Total Kjeldahl Nitrogen	mg/l as N (0.06)	0.97	45	
Orthophosphorus	mg/l as P (0.01)	0.014	76	
Chloride	mg/l (0.05)	17	41	
Sulfate	mg/l (0.05)	58	>95	
Sodium	mg/l (0.06)	6.7	30	
Potassium	mg/l (0.07)	8.8	88	
Calcium	mg/l (0.04)	16.5	64	
Magnesium	mg/l (0.006)	12.0	91	
Iron	ug/l (0.03)	20	20	

Based upon the average FTSI of 23, water quality is considered good. Brentwood Lake can be characterized as a clear (color<=10 color units), medium hard water, oligotrophic lake, with low concentrations of total phosphorus, high concentrations of total nitrogen and very high nitrate concentrations. The chemical type of water (predominant ionic composition) is calcium sulfate.

Also of note:

- Melaleuca was observed on the lake shore.

Plots and Trends: Lake surface elevation was greater in recent years (1992-1998) than for the period 1984 to 1991. Also shown is a diagram of the relative ionic composition of the lake water.

MONTHLY AVERAGE SURFACE ELEVATION

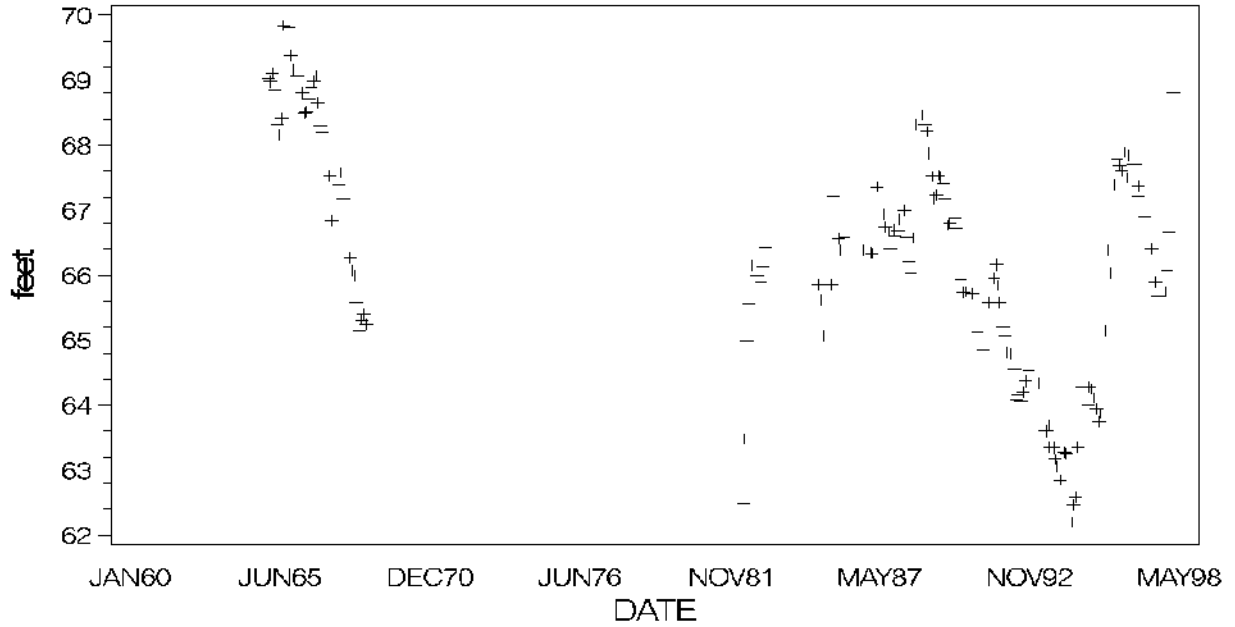

MAJOR IONS (% meq/l)

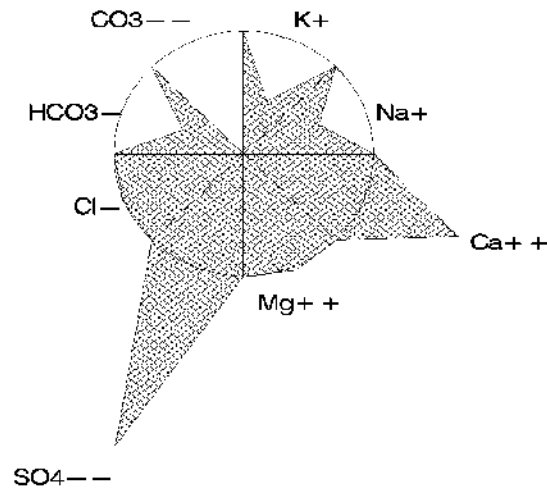

Buck Lake

Highlands County

USGS Quadrangle: Childs Major Land Use/Land Cover (1990)
 Section/Township/Range: 29-37S-30E within 500 meters of the lakeshore:
 Approx. Lake Center, Lat/Long: 271405/811958 - tree crops, typically citrus (49%)
 Surface Area: 7 acres - recreational (15%)
 Approx. Lake Elevation: 94 feet - other open lands - rural (11%)
 Lake Type: isolated (type 4)
 Major Basin: Kissimmee Ridge
 Minor Basin: Grassy Creek
 Lake Region: Southern Lake Wales Ridge

Total Number of Samples Collected: 3 Most Recent Sample Collected: January 1995

Parameter	Units (Detection Limit)	Average Value	District Percentile	Florida Percentile
Chlorophyll a	ug/l (1)	1.0	<5	<5
Total Phosphorus	mg/l as P (0.01)	0.008	31	<5
Total Nitrogen	mg/l as N (0.06)	8.02	>95	>95
Transparency (Secchi depth)	meters	7.65	>95	>95
Florida Trophic State Index		12	<5	<5
Specific Conductance	S/cm at 25C (1)	360	93	73
pH	standard units (0.1)	7.2	43	40
Color	PtCo units (1)	5	9	5
Turbidity	NTU (1)	0.5	28	<5
Total Alkalinity	mg/l as CaCO3 (1)	14	33	32
Hardness	mg/l as CaCO3 (0.02)	128	95	
Total Suspended Solids	mg/l (0.05)	0.3	<5	
Ammonia	mg/l as N (0.03)	0.015	60	
Nitrate+Nitrite	mg/l as N (0.01)	7.472	>95	
Total Kjeldahl Nitrogen	mg/l as N (0.06)	0.55	11	
Orthophosphorus	mg/l as P (0.01)	0.008	56	
Chloride	mg/l (0.05)	28	82	
Sulfate	mg/l (0.05)	46	92	
Sodium	mg/l (0.06)	5.4	16	
Potassium	mg/l (0.07)	13.3	94	
Calcium	mg/l (0.04)	28.0	90	
Magnesium	mg/l (0.006)	14.0	95	
Iron	ug/l (0.03)	8	<5	

Based upon the average FTSI of 12, water quality is considered good. Buck Lake can be characterized as a clear (color<=10 color units), hard water, oligotrophic lake, with low concentrations of total phosphorus, high concentrations of total nitrogen and very high nitrate concentrations. The chemical type of water (predominant ionic composition) is calcium sulfate.

Also of note:

- Melaleuca was observed on the lake shore.

Plots and Trends: No or insufficient data for plotting or trend detection. Shown is a diagram of the relative ionic composition of the lake water.

MAJOR IONS (% meq/l)

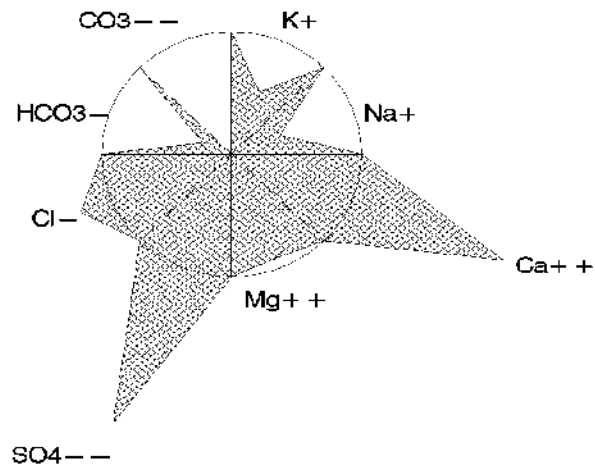

Lake Byrd

Highlands County

USGS Quadrangle: Avon Park Major Land Use/Land Cover (1990)
 Section/Township/Range: 9-33S-28E within 500 meters of the lakeshore:
 Approx. Lake Center, Lat/Long: 273718/813104 - tree crops, typically citrus (40%)
 Surface Area: 49 acres - medium density residential (20%)
 Approx. Lake Elevation: 108 feet - other open lands - rural (16%)
 Average Depth: 15.4 feet
 Observed Maximum Depth: 32 feet
 (reference elevation 107 feet)
 Lake Type: inflow and outflow (type 3)
 Major Basin: Kissimmee Ridge
 Minor Basin: Grassy Creek
 Lake Region: Southern Lake Wales Ridge

Total Number of Samples Collected: 2 Most Recent Sample Collected: January 1995

Parameter	Units (Detection Limit)	Average Value	District Percentile	Florida Percentile
Chlorophyll a	ug/l (1)	1.5	5	5
Total Phosphorus	mg/l as P (0.01)	0.009	31	<5
Total Nitrogen	mg/l as N (0.06)	4.95	>95	>95
Transparency (Secchi depth)	meters	4.00	93	>95
Florida Trophic State Index		18	<5	<5
Specific Conductance	S/cm at 25C (1)	287	86	67
pH	standard units (0.1)	6.7	21	23
Color	PtCo units (1)	5	9	5
Turbidity	NTU (1)	0.5	28	<5
Total Alkalinity	mg/l as CaCO3 (1)	15	36	33
Hardness	mg/l as CaCO3 (0.02)	98	90	
Total Suspended Solids	mg/l (0.05)	0.4	8	
Ammonia	mg/l as N (0.03)	0.015	60	
Nitrate+Nitrite	mg/l as N (0.01)	4.288	>95	
Total Kjeldahl Nitrogen	mg/l as N (0.06)	0.66	21	
Orthophosphorus	mg/l as P (0.01)	0.014	76	
Chloride	mg/l (0.05)	18	46	
Sulfate	mg/l (0.05)	67	>95	
Sodium	mg/l (0.06)	6.5	27	
Potassium	mg/l (0.07)	9.8	89	
Calcium	mg/l (0.04)	18.5	71	
Magnesium	mg/l (0.006)	12.5	92	
Iron	ug/l (0.03)	19	18	

Based upon the average FTSI of 18, water quality is considered good. Lake Byrd can be characterized as a clear (color<=10 color units), medium hard water, oligotrophic lake, with low concentrations of total phosphorus, high concentrations of total nitrogen and very high nitrate concentrations. The chemical type of water (predominant ionic composition) is calcium sulfate.

Plots and Trends: There is no trend in lake surface elevation. Also shown is a diagram of the relative ionic composition of the lake water.

MONTHLY AVERAGE SURFACE ELEVATION

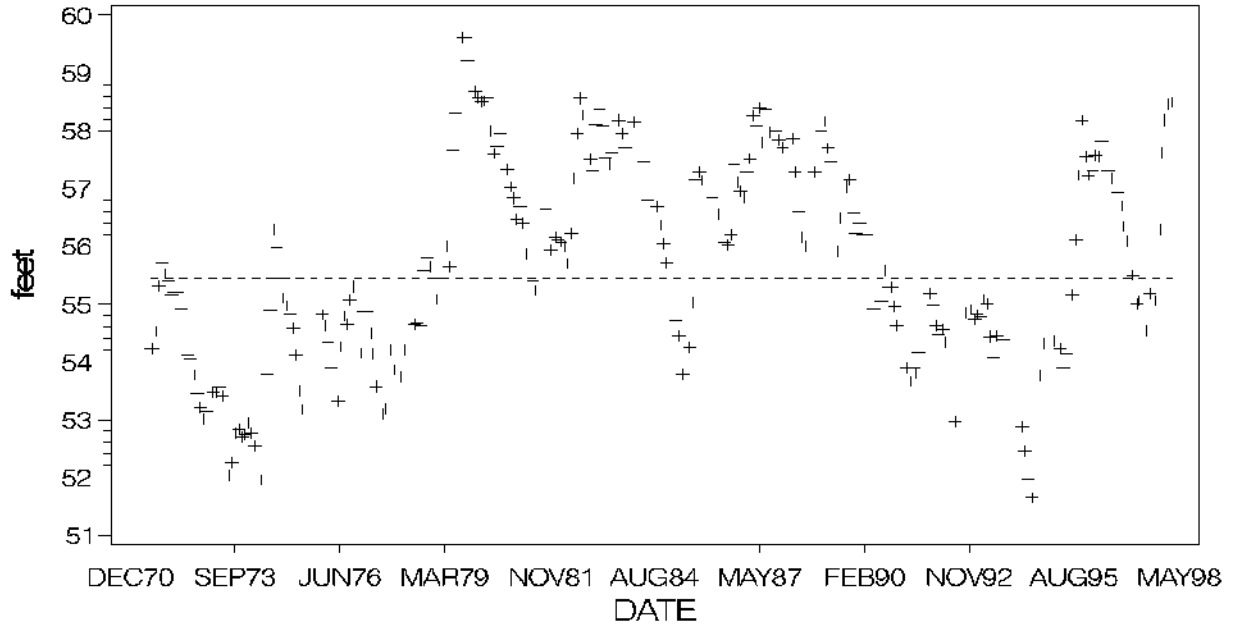

MAJOR IONS (% meq/l)

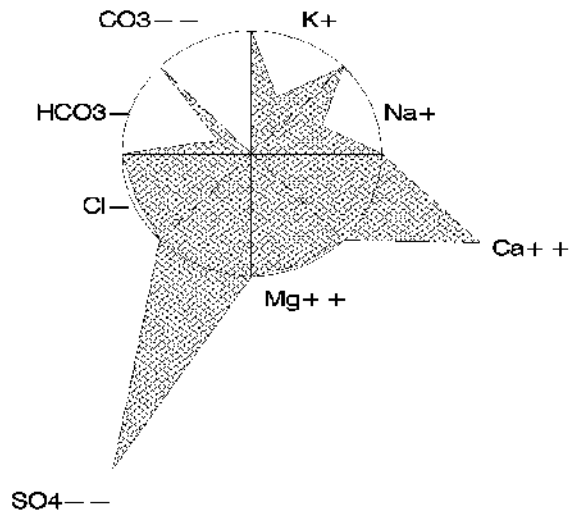

Lake Carrie

Highlands County

USGS Quadrangle: Lake June-in-Winter
 Section/Township/Range: 21-36S-29E
 Approx. Lake Center, Lat/Long: 272013/812541
 Surface Area: 65 acres
 Approx. Lake Elevation: 76 feet
 Average Depth: 8.9 feet
 Observed Maximum Depth: 13 feet
 (reference elevation 75 feet)
 Lake Type: outflow (type 2)
 Major Basin: Kissimmee Ridge
 Minor Basin: Lake Francis Outlet
 Lake Region: Lake Wales Ridge Transition
 Public Access: yes

Major Land Use/Land Cover (1990)
 within 500 meters of the lakeshore:
 - open land (72%)
 - medium density residential (13%)
 - low density residential (8%)

Total Number of Samples Collected: 3 Most Recent Sample Collected: January 1995

Parameter	Units (Detection Limit)	Average Value	District Percentile	Florida Percentile
Chlorophyll a	ug/l (1)	15.0	74	45
Total Phosphorus	mg/l as P (0.01)	0.038	82	28
Total Nitrogen	mg/l as N (0.06)	1.20	55	40
Transparency (Secchi depth)	meters	0.46	5	14
Florida Trophic State Index		64	89	64
Specific Conductance	S/cm at 25C (1)	77	6	14
pH	standard units (0.1)	6.9	29	28
Color	PtCo units (1)	175	>95	94
Turbidity	NTU (1)	8.1	84	64
Total Alkalinity	mg/l as CaCO3 (1)	10	27	25
Hardness	mg/l as CaCO3 (0.02)	25	14	
Total Suspended Solids	mg/l (0.05)	4.2	74	
Ammonia	mg/l as N (0.03)	0.021	60	
Nitrate+Nitrite	mg/l as N (0.01)	0.040	65	
Total Kjeldahl Nitrogen	mg/l as N (0.06)	1.16	59	
Orthophosphorus	mg/l as P (0.01)	0.020	85	
Chloride	mg/l (0.05)	9	12	
Sulfate	mg/l (0.05)	4	17	
Sodium	mg/l (0.06)	4.1	9	
Potassium	mg/l (0.07)	0.7	14	
Calcium	mg/l (0.04)	8.3	29	
Magnesium	mg/l (0.006)	1.1	8	
Iron	ug/l (0.03)	75	73	

Based upon the average FTSI of 64, water quality is considered fair. Lake Carrie can be characterized as a highly colored, soft water, meso-eutrophic lake, with high concentrations of total phosphorus. The chemical type of water (predominant ionic composition) is calcium chloride.

Plots and Trends: No or insufficient data for plotting or trend detection. Shown is a diagram of the relative ionic composition of the lake water.

MAJOR IONS (% meq/l)

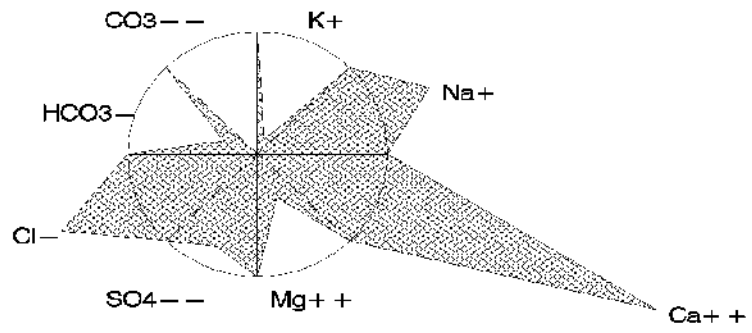

Lake Charlotte

Highlands County

USGS Quadrangle: Sebring Major Land Use/Land Cover (1990)
 Section/Township/Range: 17-35S-29E within 500 meters of the lakeshore:
 Approx. Lake Center, Lat/Long: 272558/812702 - cropland and pastureland (33%)
 Surface Area: 104 acres - low density residential (33%)
 Approx. Lake Elevation: 94 feet - pine flatwoods (18%)
 Average Depth: 11.5 feet
 Observed Maximum Depth: 22 feet
 (reference elevation 92.94 feet)
 Lake Type: inflow and outflow (type 3)
 Major Basin: Kissimmee Ridge
 Minor Basin: Lake Charlotte Outlet
 Lake Region: Lake Wales Ridge Transition

Total Number of Samples Collected: 2 Most Recent Sample Collected: February 1995

Parameter	Units (Detection Limit)	Average Value	District Percentile	Florida Percentile
Chlorophyll a	ug/l (1)	4.0	36	16
Total Phosphorus	mg/l as P (0.01)	0.096	93	65
Total Nitrogen	mg/l as N (0.06)	0.77	25	24
Transparency (Secchi depth)	meters	1.43	47	75
Florida Trophic State Index		46	65	27
Specific Conductance	S/cm at 25C (1)	75	5	14
pH	standard units (0.1)	4.5	<5	<5
Color	PtCo units (1)	30	67	23
Turbidity	NTU (1)	2.9	62	31
Total Alkalinity	mg/l as CaCO3 (1)	1	<5	<5
Hardness	mg/l as CaCO3 (0.02)	12	<5	
Total Suspended Solids	mg/l (0.05)	1.9	49	
Ammonia	mg/l as N (0.03)	0.027	60	
Nitrate+Nitrite	mg/l as N (0.01)	0.043	67	
Total Kjeldahl Nitrogen	mg/l as N (0.06)	0.73	27	
Orthophosphorus	mg/l as P (0.01)	0.087	>95	
Chloride	mg/l (0.05)	12	23	
Sulfate	mg/l (0.05)	10	37	
Sodium	mg/l (0.06)	6.7	30	
Potassium	mg/l (0.07)	1.1	20	
Calcium	mg/l (0.04)	2.4	<5	
Magnesium	mg/l (0.006)	1.4	15	
Iron	ug/l (0.03)	90	79	

Based upon the average FTSI of 46, water quality is considered good. Lake Charlotte can be characterized as a moderately colored, soft water, oligo-mesotrophic lake, with high concentrations of total phosphorus. The chemical type of water (predominant ionic composition) is sodium chloride.

Also of note:

- The measured pH was very low.

Plots and Trends: Lake levels in the 1990s appear to be somewhat greater than those recorded during the 1980s. This is reflective of the increasing trend in rainfall from the period of relative drought in the mid- and late 1980s in the Lake Wales Ridge region. Also shown is a diagram of the relative ionic composition of the lake water.

MONTHLY AVERAGE SURFACE ELEVATION

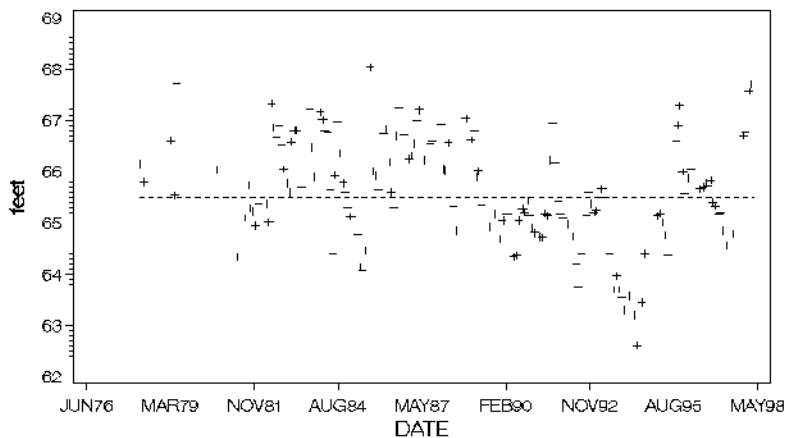

CHLOROPHYLL a

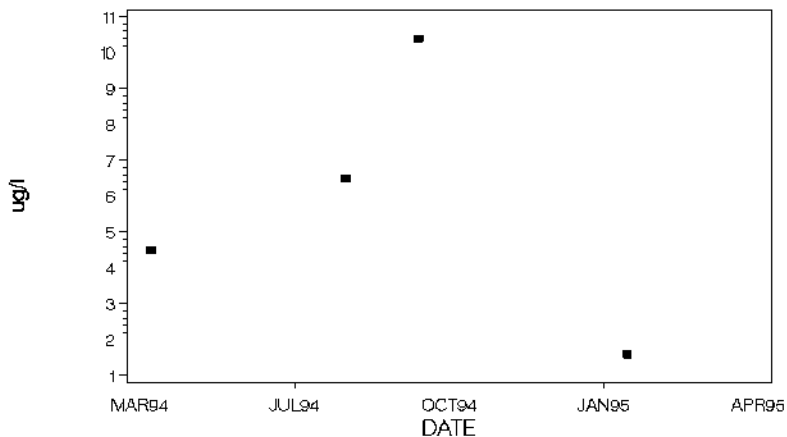

MAJOR IONS (% meq/l)

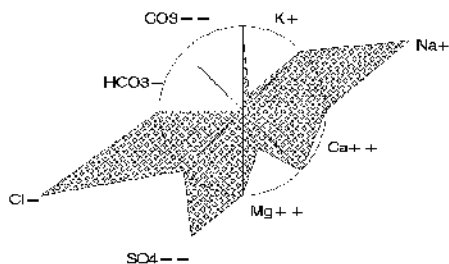

Chilton Lake

Highlands County

USGS Quadrangle: Frostproof Major Land Use/Land Cover (1990)
 Section/Township/Range: 7-33S-28E within 500 meters of the lakeshore:
 Approx. Lake Center, Lat/Long: 273754/813322 - low density residential (82%)
 Surface Area: 23 acres - medium density residential (16%)
 Approx. Lake Elevation: 114 feet - cropland and pastureland (2%)
 Average Depth: 12.1 feet
 Observed Maximum Depth: 22 feet
 (reference elevation 112 feet)
 Lake Type: isolated (type 4)
 Major Basin: Peace River
 Minor Basin: Old Town Creek
 Lake Region: Southern Lake Wales Ridge
 Public Access: yes

Total Number of Samples Collected: 2 Most Recent Sample Collected: January 1995

Parameter	Units (Detection Limit)	Average Value	District Percentile	Florida Percentile
Chlorophyll a	ug/l (1)	6.1	50	26
Total Phosphorus	mg/l as P (0.01)	0.012	41	6
Total Nitrogen	mg/l as N (0.06)	0.62	12	16
Transparency (Secchi depth)	meters	2.45	74	91
Florida Trophic State Index		35	42	10
Specific Conductance	S/cm at 25C (1)	57	<5	7
pH	standard units (0.1)	6.0	5	8
Color	PtCo units (1)	13	41	12
Turbidity	NTU (1)	0.8	28	<5
Total Alkalinity	mg/l as CaCO3 (1)	3	7	8
Hardness	mg/l as CaCO3 (0.02)	10	<5	
Total Suspended Solids	mg/l (0.05)	1.4	37	
Ammonia	mg/l as N (0.03)	0.015	60	
Nitrate+Nitrite	mg/l as N (0.01)	0.005	33	
Total Kjeldahl Nitrogen	mg/l as N (0.06)	0.62	17	
Orthophosphorus	mg/l as P (0.01)	0.014	76	
Chloride	mg/l (0.05)	9	12	
Sulfate	mg/l (0.05)	7	27	
Sodium	mg/l (0.06)	5.6	18	
Potassium	mg/l (0.07)	1.2	21	
Calcium	mg/l (0.04)	2.3	<5	
Magnesium	mg/l (0.006)	1.0	6	
Iron	ug/l (0.03)	32	41	

Based upon the average FTSI of 35, water quality is considered good. Chilton Lake can be characterized as a clear to moderately colored (10<color<20 color units), soft water, meso-eutrophic lake, with low concentrations of total nitrogen. The chemical type of water (predominant ionic composition) is sodium chloride.

Also of note: -
 - The measured pH was low.

Plots and Trends: Lake levels in the 1990s are generally greater than those recorded during the 1980s. This is reflective of the increasing trend in rainfall following the period of relative drought in the mid- and late 1980s in the Lake Wales Ridge region. There were insufficient water chemistry data for plotting or trend detection. Shown is a diagram of the relative ionic composition of the lake water.

MAJOR IONS (% meq/l)

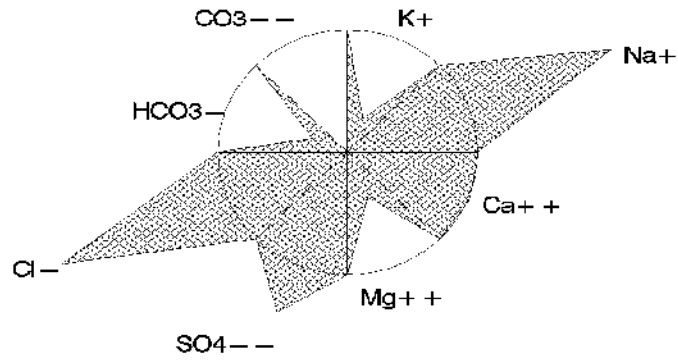

Lake Clay

Highlands County

USGS Quadrangle: Lake Placid Major Land Use/Land Cover (1990)
 Section/Township/Range: 29-36S-30E within 500 meters of the lakeshore:
 Approx. Lake Center, Lat/Long: 271840/812052 - medium density residential (44%)
 Surface Area: 367 acres - tree crops, typically citrus (17%)
 Approx. Lake Elevation: 79 feet - high density residential (9%)
 Average Depth: 9.2 feet
 Observed Maximum Depth: 25 feet
 (reference elevation 78 feet)
 Lake Type: inflow and outflow (type 3)
 Major Basin: Kissimmee Ridge
 Minor Basin: Grassy Creek
 Lake Region: Southern Lake Wales Ridge
 Public Access: yes

Total Number of Samples Collected: 2 Most Recent Sample Collected: January 1995

Parameter	Units (Detection Limit)	Average Value	District Percentile	Florida Percentile
Chlorophyll a	ug/l (1)	4.4	40	18
Total Phosphorus	mg/l as P (0.01)	0.005	31	<5
Total Nitrogen	mg/l as N (0.06)	0.99	40	33
Transparency (Secchi depth)	meters	2.70	78	93
Florida Trophic State Index		33	36	7
Specific Conductance	S/cm at 25C (1)	170	45	46
pH	standard units (0.1)	6.9	29	28
Color	PtCo units (1)	5	9	5
Turbidity	NTU (1)	1.7	45	16
Total Alkalinity	mg/l as CaCO3 (1)	5	13	13
Hardness	mg/l as CaCO3 (0.02)	35	28	
Total Suspended Solids	mg/l (0.05)	2.0	51	
Ammonia	mg/l as N (0.03)	0.015	60	
Nitrate+Nitrite	mg/l as N (0.01)	0.038	63	
Total Kjeldahl Nitrogen	mg/l as N (0.06)	0.96	44	
Orthophosphorus	mg/l as P (0.01)	0.010	59	
Chloride	mg/l (0.05)	21	61	
Sulfate	mg/l (0.05)	31	79	
Sodium	mg/l (0.06)	11.0	64	
Potassium	mg/l (0.07)	6.1	73	
Calcium	mg/l (0.04)	6.0	20	
Magnesium	mg/l (0.006)	4.9	68	
Iron	ug/l (0.03)	12	5	

Based upon the average FTSI of 33, water quality is considered good. Lake Clay can be characterized as a clear (color<=10 color units), soft water, mesotrophic lake, with low concentrations of total phosphorus. The chemical type of water (predominant ionic composition) is sodium chloride (1 sample) or sodium sulfate (1 sample).

Plots and Trends: Similar to plots of lake elevation for other lakes in the Lake Wales Ridge region, lake levels have generally increased during the 1990s, following drought years in the mid- to late 1980s. No clear trends are evident in the plots of water quality. Also shown is a diagram of the relative ionic composition of the lake water.

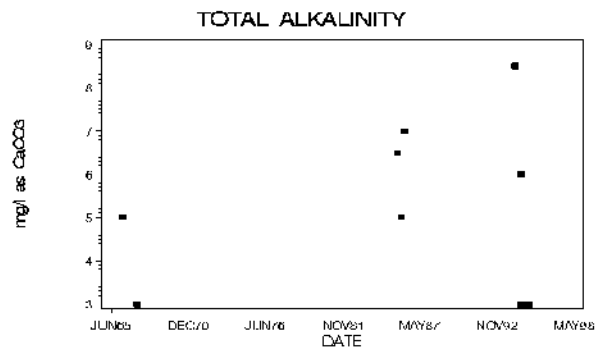
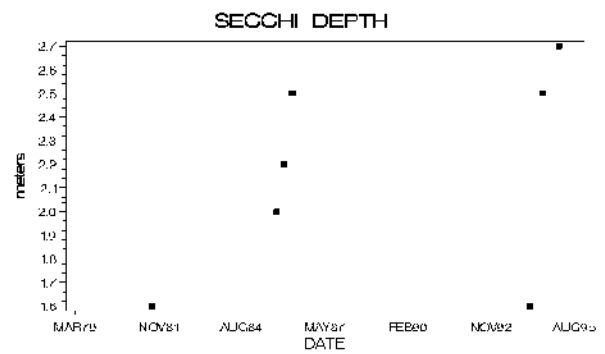
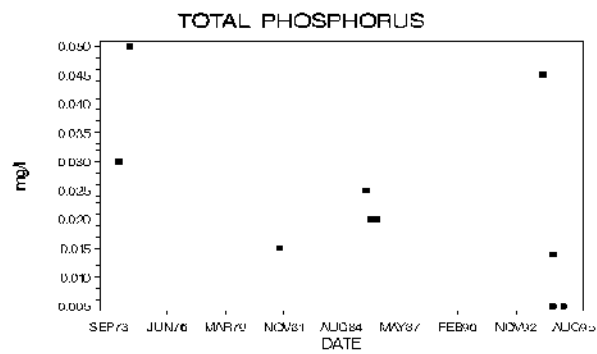
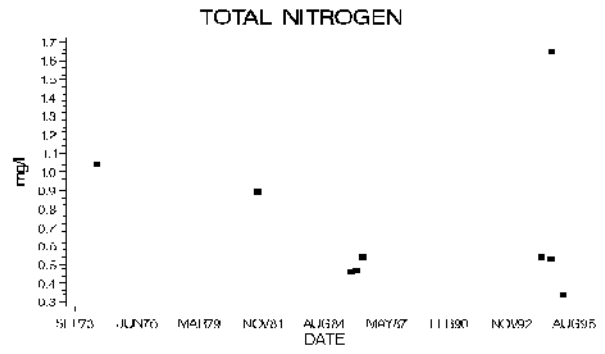
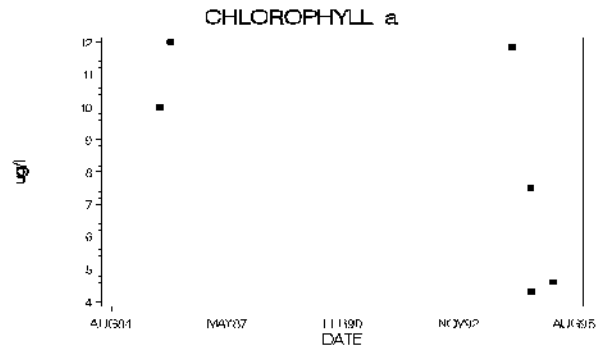
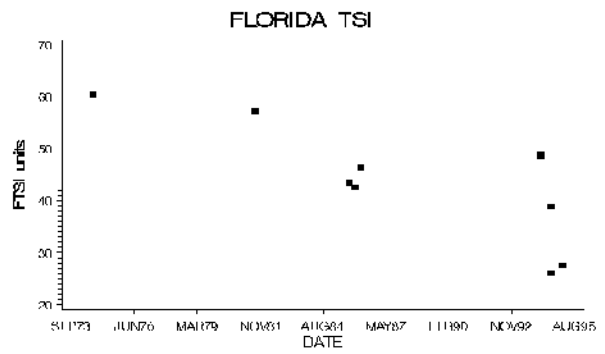
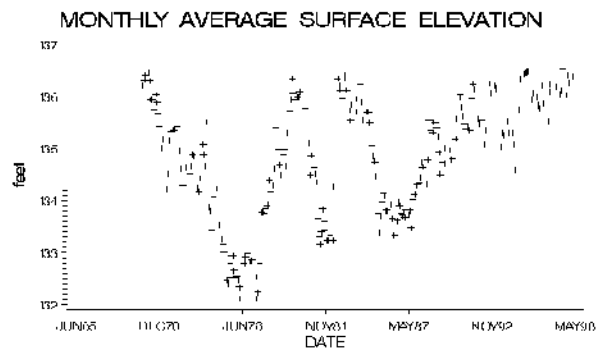

MAJOR IONS (% meq/l)

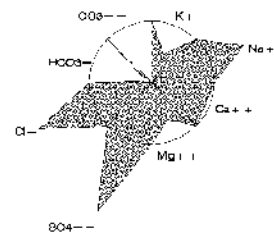

Lake Clay, Highlands County

Lake Crews Highlands County

USGS Quadrangle: Lake June-in-Winter
 Section/Township/Range: 32-36S-29E
 Approx. Lake Center, Lat/Long: 271745/812612
 Surface Area: 62 acres
 Approx. Lake Elevation: 120 feet
 Average Depth: 8.5 feet
 Observed Maximum Depth: 17 feet
 (reference elevation 120 feet)
 Lake Type: isolated (type 4)
 Major Basin: Kissimmee Ridge
 Minor Basin: Lake Francis Outlet
 Lake Region: Lake Wales Ridge Transition
 Public Access: yes

Major Land Use/Land Cover (1990)
 within 500 meters of the lakeshore:
 - cropland and pastureland (53%)
 - pine flatwoods (17%)
 - open land (16%)

Total Number of Samples Collected: 3 Most Recent Sample Collected: January 1995

Parameter	Units (Detection Limit)	Average Value	District Percentile	Florida Percentile
Chlorophyll a	ug/l (1)	14.1	73	44
Total Phosphorus	mg/l as P (0.01)	0.031	77	21
Total Nitrogen	mg/l as N (0.06)	1.11	49	37
Transparency (Secchi depth)	meters	0.95	31	62
Florida Trophic State Index		51	74	36
Specific Conductance	S/cm at 25C (1)	76	6	14
pH	standard units (0.1)	6.2	8	10
Color	PtCo units (1)	32	68	25
Turbidity	NTU (1)	4.7	73	48
Total Alkalinity	mg/l as CaCO3 (1)	2	<5	5
Hardness	mg/l as CaCO3 (0.02)	11	<5	
Total Suspended Solids	mg/l (0.05)	4.3	75	
Ammonia	mg/l as N (0.03)	0.015	60	
Nitrate+Nitrite	mg/l as N (0.01)	0.019	50	
Total Kjeldahl Nitrogen	mg/l as N (0.06)	1.09	54	
Orthophosphorus	mg/l as P (0.01)	0.013	72	
Chloride	mg/l (0.05)	14	30	
Sulfate	mg/l (0.05)	5	20	
Sodium	mg/l (0.06)	6.9	32	
Potassium	mg/l (0.07)	0.6	13	
Calcium	mg/l (0.04)	2.2	<5	
Magnesium	mg/l (0.006)	1.3	12	
Iron	ug/l (0.03)	29	37	

Based upon the average FTSI of 51, water quality is considered good. Lake Crews can be characterized as a moderately colored, soft water, oligo-mesotrophic lake. The chemical type of water (predominant ionic composition) is sodium chloride.

Plots and Trends: No or insufficient data for plotting or trend detection. Shown is a diagram of the relative ionic composition of the lake water.

MAJOR IONS (% meq/l)

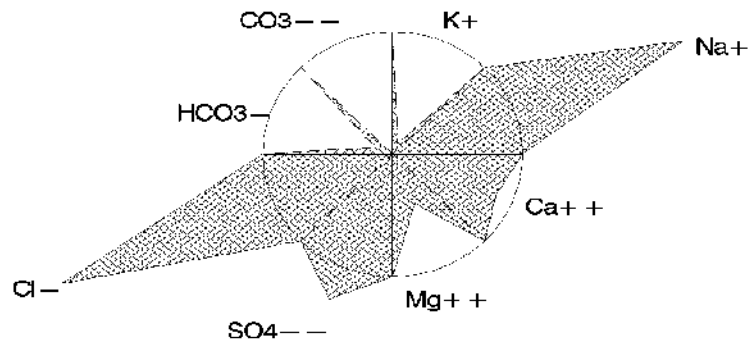

Lake Crews, Highlands County

Lake Damon

Highlands County

USGS Quadrangle: Frostproof Major Land Use/Land Cover (1990)
 Section/Township/Range: 3-33S-28E within 500 meters of the lakeshore:
 Approx. Lake Center, Lat/Long: 273760/813033 - cropland and pastureland (27%)
 Surface Area: 282 acres - low density residential (20%)
 Approx. Lake Elevation: 101 feet - tree crops, typically citrus (17%)
 Average Depth: 6.9 feet
 Observed Maximum Depth: 15 feet
 (reference elevation 93.1 feet)
 Lake Type: inflow and outflow (type 3)
 Major Basin: Kissimmee Ridge
 Minor Basin: Grassy Creek
 Lake Region: Southern Lake Wales Ridge
 Public Access: yes

Total Number of Samples Collected: 2 Most Recent Sample Collected: January 1995

Parameter	Units (Detection Limit)	Average Value	District Percentile	Florida Percentile
Chlorophyll a	ug/l (1)	5.7	47	24
Total Phosphorus	mg/l as P (0.01)	0.014	50	7
Total Nitrogen	mg/l as N (0.06)	0.75	23	23
Transparency (Secchi depth)	meters	1.60	52	78
Florida Trophic State Index		42	57	19
Specific Conductance	S/cm at 25C (1)	244	76	59
pH	standard units (0.1)	7.1	38	35
Color	PtCo units (1)	8	24	8
Turbidity	NTU (1)	1.9	49	19
Total Alkalinity	mg/l as CaCO3 (1)	24	48	43
Hardness	mg/l as CaCO3 (0.02)	79	79	
Total Suspended Solids	mg/l (0.05)	3.6	69	
Ammonia	mg/l as N (0.03)	0.015	60	
Nitrate+Nitrite	mg/l as N (0.01)	0.022	54	
Total Kjeldahl Nitrogen	mg/l as N (0.06)	0.73	27	
Orthophosphorus	mg/l as P (0.01)	0.014	76	
Chloride	mg/l (0.05)	20	56	
Sulfate	mg/l (0.05)	53	94	
Sodium	mg/l (0.06)	8.8	50	
Potassium	mg/l (0.07)	8.6	88	
Calcium	mg/l (0.04)	14.0	56	
Magnesium	mg/l (0.006)	10.5	88	
Iron	ug/l (0.03)	30	39	

Based upon the average FTSI of 42, water quality is considered good. Lake Damon can be characterized as a clear (color<=10 color units), medium hard water, mesotrophic lake. The chemical type of water (predominant ionic composition) is calcium sulfate.

Plots and Trends: Similar to plots of lake elevation for other lakes in the Lake Wales Ridge region, Lake Damon surface elevations have generally increased during the 1990s, recovering from the drought years in the mid- to late 1980s in the Lake Wales Ridge region. Also shown is a diagram of the relative ionic composition of the lake water.

MONTHLY AVERAGE SURFACE ELEVATION

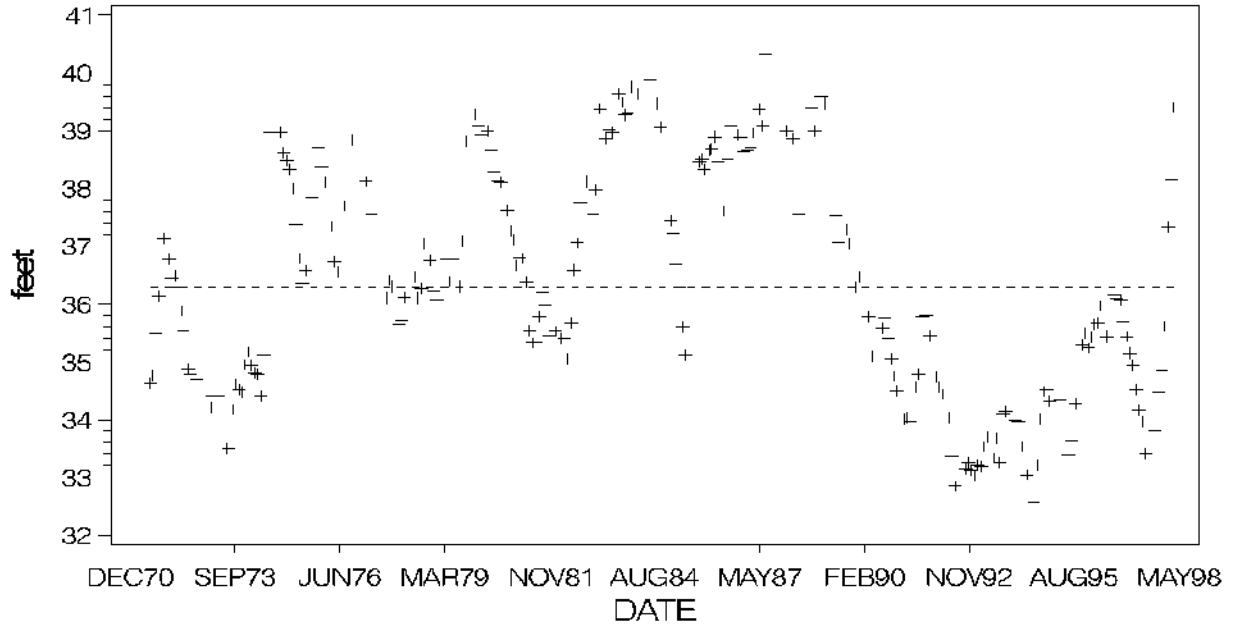

MAJOR IONS (% meq/l)

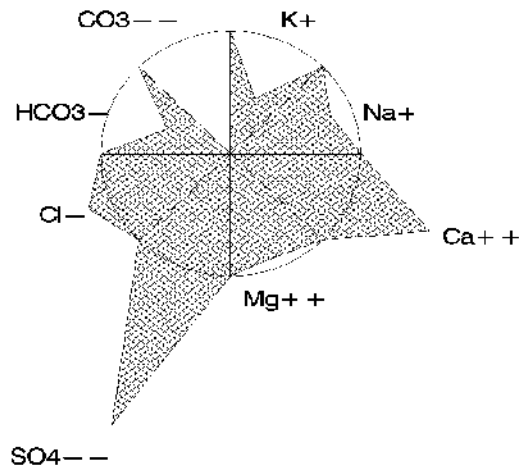

Deer Lake Highlands County

USGS Quadrangle: Lake Arbuckle SW Major Land Use/Land Cover (1990)
 Section/Township/Range: 13-33S-28E within 500 meters of the lakeshore:
 Approx. Lake Center, Lat/Long: 273633/812828 - tree crops, typically citrus (85%)
 Surface Area: 28 acres - disturbed land (7%)
 Approx. Lake Elevation: 98 feet - medium density residential (5%)
 Lake Type: isolated (type 4)
 Major Basin: Kissimmee Ridge
 Minor Basin: Bonnet Creek
 Lake Region: Southern Lake Wales Ridge

Total Number of Samples Collected: 2 Most Recent Sample Collected: January 1995

Parameter	Units (Detection Limit)	Average Value	District Percentile	Florida Percentile
Chlorophyll a	ug/l (1)	2.9	23	12
Total Phosphorus	mg/l as P (0.01)	0.018	61	9
Total Nitrogen	mg/l as N (0.06)	1.84	81	77
Transparency (Secchi depth)	meters	2.60	77	93
Florida Trophic State Index		36	43	10
Specific Conductance	S/cm at 25C (1)	143	33	40
pH	standard units (0.1)	7.2	43	40
Color	PtCo units (1)	5	9	5
Turbidity	NTU (1)	0.8	28	<5
Total Alkalinity	mg/l as CaCO3 (1)	10	27	25
Hardness	mg/l as CaCO3 (0.02)	43	41	
Total Suspended Solids	mg/l (0.05)	1.2	33	
Ammonia	mg/l as N (0.03)	0.015	60	
Nitrate+Nitrite	mg/l as N (0.01)	0.155	85	
Total Kjeldahl Nitrogen	mg/l as N (0.06)	1.69	82	
Orthophosphorus	mg/l as P (0.01)	0.017	83	
Chloride	mg/l (0.05)	11	19	
Sulfate	mg/l (0.05)	30	77	
Sodium	mg/l (0.06)	4.0	8	
Potassium	mg/l (0.07)	6.8	80	
Calcium	mg/l (0.04)	6.4	22	
Magnesium	mg/l (0.006)	6.6	79	
Iron	ug/l (0.03)	23	27	

Based upon the average FTSI of 36, water quality is considered good. Deer Lake can be characterized as a clear (color<=10 color units), soft water, oligotrophic lake. The chemical type of water (predominant ionic composition) is calcium sulfate.

Plots and Trends: No or insufficient data for plotting or trend detection. Shown is a diagram of the relative ionic composition of the lake water.

MAJOR IONS (% meq/l)

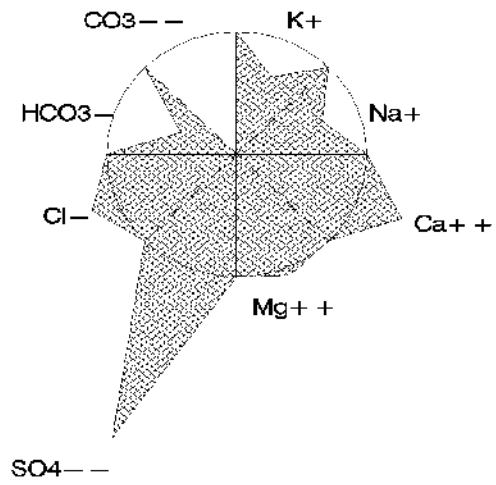

Deer Lake, Highlands County

Lake Denton Highlands County

USGS Quadrangle: Lake Arbuckle SW Major Land Use/Land Cover (1990)
 Section/Township/Range: 2-34S-28E within 500 meters of the lakeshore:
 Approx. Lake Center, Lat/Long: 273322/812923 - tree crops, typically citrus (64%)
 Surface Area: 66 acres - medium density residential (10%)
 Approx. Lake Elevation: 117 feet - other open lands - rural (8%)
 Average Depth: 23.9 feet
 Observed Maximum Depth: 51 feet
 (reference elevation 111 feet)
 Lake Type: isolated (type 4)
 Major Basin: Kissimmee Ridge
 Minor Basin: Little Red Water Lk 01
 Lake Region: Southern Lake Wales Ridge
 Public Access: yes

Total Number of Samples Collected: 2 Most Recent Sample Collected: January 1995

Parameter	Units (Detection Limit)	Average Value	District Percentile	Florida Percentile
Chlorophyll a	ug/l (1)	3.3	28	14
Total Phosphorus	mg/l as P (0.01)	0.009	31	<5
Total Nitrogen	mg/l as N (0.06)	7.64	>95	>95
Transparency (Secchi depth)	meters	6.55	>95	>95
Florida Trophic State Index		19	6	<5
Specific Conductance	S/cm at 25C (1)	296	87	68
pH	standard units (0.1)	8.0	81	70
Color	PtCo units (1)	5	9	5
Turbidity	NTU (1)	0.5	28	<5
Total Alkalinity	mg/l as CaCO3 (1)	29	57	48
Hardness	mg/l as CaCO3 (0.02)	105	92	
Total Suspended Solids	mg/l (0.05)	0.4	8	
Ammonia	mg/l as N (0.03)	0.015	60	
Nitrate+Nitrite	mg/l as N (0.01)	6.404	>95	
Total Kjeldahl Nitrogen	mg/l as N (0.06)	1.24	64	
Orthophosphorus	mg/l as P (0.01)	0.014	76	
Chloride	mg/l (0.05)	27	80	
Sulfate	mg/l (0.05)	37	86	
Sodium	mg/l (0.06)	5.5	16	
Potassium	mg/l (0.07)	11.0	91	
Calcium	mg/l (0.04)	20.5	77	
Magnesium	mg/l (0.006)	13.0	93	
Iron	ug/l (0.03)	12	6	

Based upon the average FTSI of 19, water quality is considered good. Lake Denton can be characterized as a clear (color<=10 color units), medium hard water, oligo-mesotrophic lake, with low concentrations of total phosphorus, high concentrations of total nitrogen and very high nitrate concentrations. The chemical type of water (predominant ionic composition) is calcium sulfate.

Also of note:

- The measured pH was high.

Plots and Trends: Similar to plots of lake elevation for other lakes in the Lake Wales Ridge region, Lake Denton surface elevations have generally increased during the 1990s, recovering from the drought years in the mid- to late 1980s in the Lake Wales Ridge region. Also shown is a diagram of the relative ionic composition of the lake water.

MONTHLY AVERAGE SURFACE ELEVATION

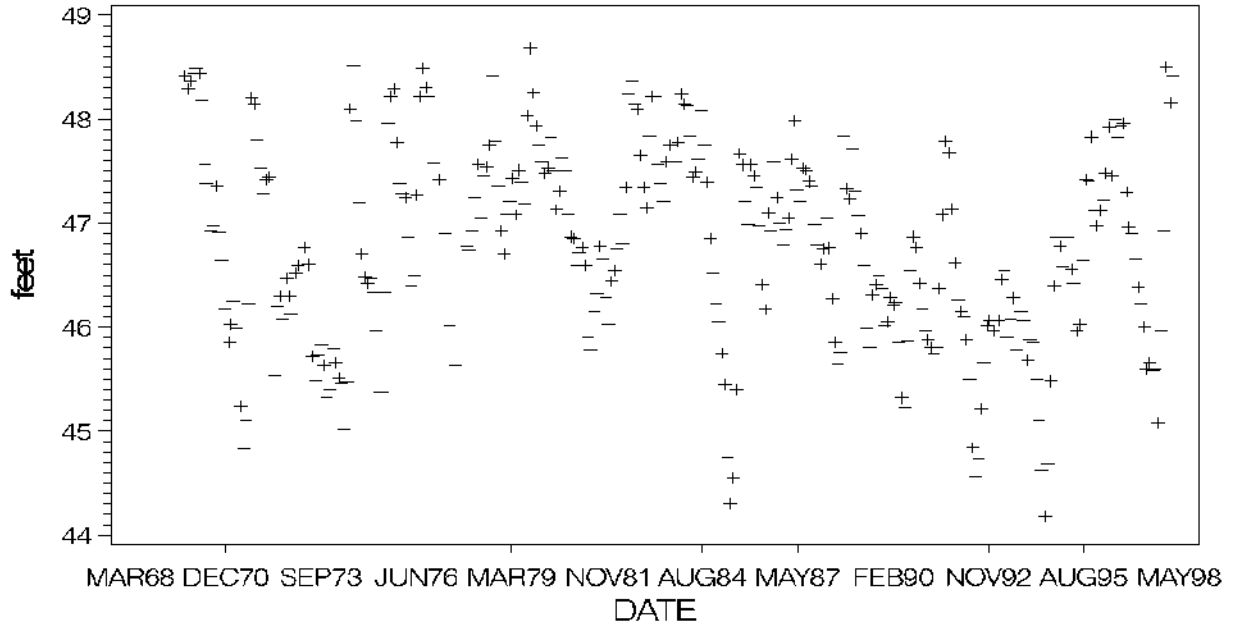

MAJOR IONS (% meq/l)

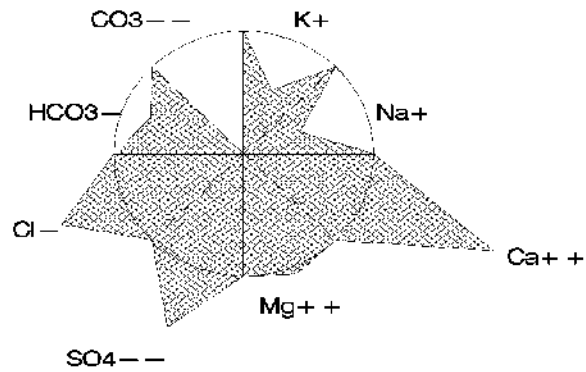

Dinner Lake Highlands County

USGS Quadrangle: Lake Arbuckle SW Major Land Use/Land Cover (1990)
 Section/Township/Range: 17-34S-29E within 500 meters of the lakeshore:
 Approx. Lake Center, Lat/Long: 273056/812634 - medium density residential (47%)
 Surface Area: 379 acres - tree crops, typically citrus (40%)
 Approx. Lake Elevation: 103 feet - herbaceous range (3%)
 Average Depth: 15.4 feet
 Observed Maximum Depth: 31 feet
 (reference elevation 99 feet)
 Lake Type: isolated (type 4)
 Major Basin: Kissimmee Ridge
 Minor Basin: Carter Creek
 Lake Region: Southern Lake Wales Ridge
 Public Access: yes

Total Number of Samples Collected: 2 Most Recent Sample Collected: January 1995

Parameter	Units (Detection Limit)	Average Value	District Percentile	Florida Percentile
Chlorophyll a	ug/l (1)	4.7	42	19
Total Phosphorus	mg/l as P (0.01)	0.009	31	<5
Total Nitrogen	mg/l as N (0.06)	0.38	<5	<5
Transparency (Secchi depth)	meters	2.50	75	92
Florida Trophic State Index		31	29	6
Specific Conductance	S/cm at 25C (1)	203	60	52
pH	standard units (0.1)	7.8	74	63
Color	PtCo units (1)	5	9	5
Turbidity	NTU (1)	1.7	45	16
Total Alkalinity	mg/l as CaCO3 (1)	32	62	51
Hardness	mg/l as CaCO3 (0.02)	64	67	
Total Suspended Solids	mg/l (0.05)	2.0	51	
Ammonia	mg/l as N (0.03)	0.015	60	
Nitrate+Nitrite	mg/l as N (0.01)	0.097	81	
Total Kjeldahl Nitrogen	mg/l as N (0.06)	0.28	<5	
Orthophosphorus	mg/l as P (0.01)	0.014	76	
Chloride	mg/l (0.05)	16	37	
Sulfate	mg/l (0.05)	33	82	
Sodium	mg/l (0.06)	7.9	43	
Potassium	mg/l (0.07)	6.6	79	
Calcium	mg/l (0.04)	13.0	53	
Magnesium	mg/l (0.006)	7.6	82	
Iron	ug/l (0.03)	17	12	

Based upon the average FTSI of 31, water quality is considered good. Dinner Lake can be characterized as a clear (color<=10 color units), medium hard water, oligo-mesotrophic lake, with low concentrations of total phosphorus and very low concentrations of total nitrogen. The chemical type of water (predominant ionic composition) is calcium sulfate.

Plots and Trends: Similar to plots of lake elevation for other lakes in the Lake Wales Ridge region, Dinner Lake surface elevations have generally increased during the 1990s, recovering from the drought years in the mid- to late 1980s in the Lake Wales Ridge region. Also shown is a diagram of the relative ionic composition of the lake water.

MONTHLY AVERAGE SURFACE ELEVATION

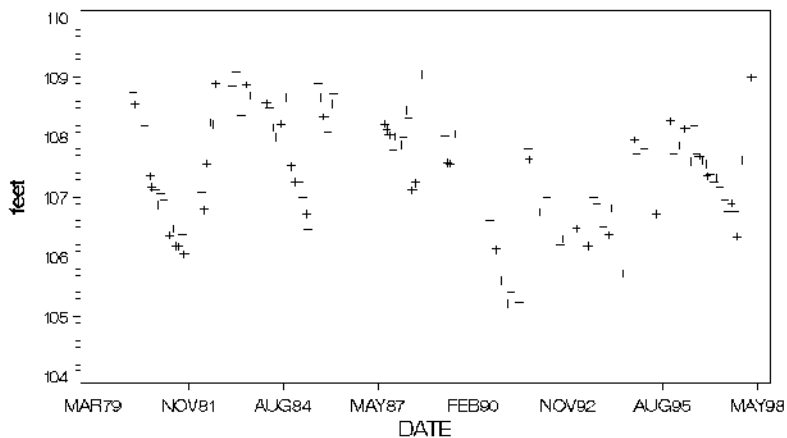

CHLOROPHYLL a

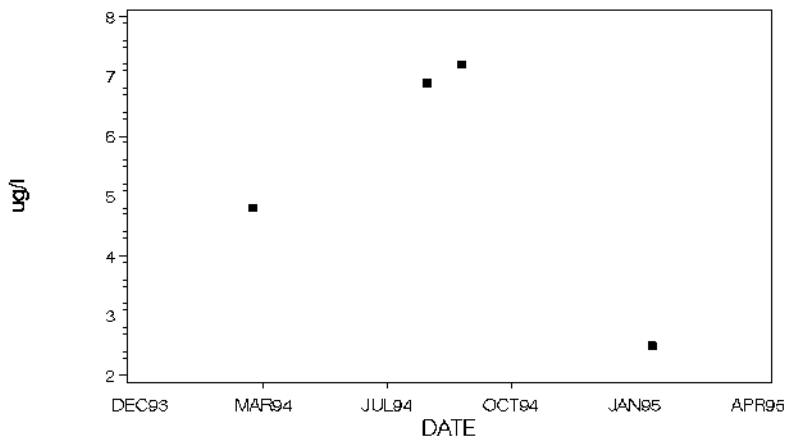

MAJOR IONS (% meq/l)

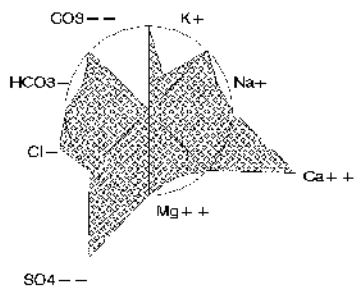

Dinner Lake, Highlands County

Duck Lake

Highlands County

USGS Quadrangle: Lake Arbuckle SW Major Land Use/Land Cover (1990)
 Section/Township/Range: 13-33S-28E within 500 meters of the lakeshore:
 Approx. Lake Center, Lat/Long: 273645/812844 - tree crops, typically citrus (74%)
 Surface Area: 7 acres - disturbed land (18%)
 Approx. Lake Elevation: 98 feet - medium density residential (8%)
 Lake Type: isolated (type 4)
 Major Basin: Kissimmee Ridge
 Minor Basin: Bonnet Creek
 Lake Region: Southern Lake Wales Ridge

Total Number of Samples Collected: 2 Most Recent Sample Collected: January 1996

Parameter	Units (Detection Limit)	Average Value	District Percentile	Florida Percentile
Chlorophyll a	ug/l (1)	22.1	81	55
Total Phosphorus	mg/l as P (0.01)	0.021	66	11
Total Nitrogen	mg/l as N (0.06)	1.46	68	56
Transparency (Secchi depth)	meters	0.75	21	45
Florida Trophic State Index		50	73	35
Specific Conductance	S/cm at 25C (1)	1071	>95	94
pH	standard units (0.1)	7.3	50	45
Color	PtCo units (1)	18	51	15
Turbidity	NTU (1)	3.3	65	35
Total Alkalinity	mg/l as CaCO3 (1)	24	48	43
Hardness	mg/l as CaCO3 (0.02)	38	32	
Total Suspended Solids	mg/l (0.05)	3.8	71	
Ammonia	mg/l as N (0.03)	0.118	90	
Nitrate+Nitrite	mg/l as N (0.01)	0.153	85	
Total Kjeldahl Nitrogen	mg/l as N (0.06)	1.30	68	
Orthophosphorus	mg/l as P (0.01)	0.008	56	
Chloride	mg/l (0.05)	6	5	
Sulfate	mg/l (0.05)	13	45	
Sodium	mg/l (0.06)	2.9	<5	
Potassium	mg/l (0.07)	3.9	54	
Calcium	mg/l (0.04)	8.7	32	
Magnesium	mg/l (0.006)	3.8	56	
Iron	ug/l (0.03)	111	84	

Based upon the average FTSI of 50, water quality is considered good. Duck Lake can be characterized as a clear to moderately colored (10<color<20 color units), soft water, eutrophic lake. The chemical type of water (predominant ionic composition) is calcium bicarbonate (1 sample) or calcium sulfate.

Plots and Trends: No or insufficient data for plotting or trend detection. Shown is a diagram of the relative ionic composition of the lake water.

MAJOR IONS (% meq/l)

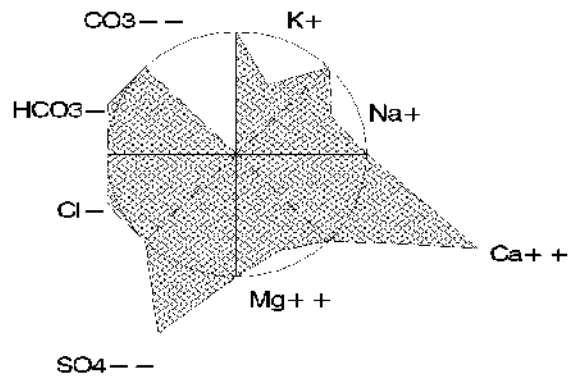

Duck Lake, Highlands County

Fox Lake

Highlands County

USGS Quadrangle: Lake Arbuckle SW Major Land Use/Land Cover (1990)
 Section/Township/Range: 13-33S-28E within 500 meters of the lakeshore:
 Approx. Lake Center, Lat/Long: 273628/812801 - tree crops, typically citrus (98%)
 Surface Area: 28 acres - medium density residential (2%)
 Approx. Lake Elevation: 100 feet
 Lake Type: isolated (type 4)
 Major Basin: Kissimmee Ridge
 Minor Basin: Bonnet Creek
 Lake Region: Southern Lake Wales Ridge

Total Number of Samples Collected: 2 Most Recent Sample Collected: January 1996

Parameter	Units (Detection Limit)	Average Value	District Percentile	Florida Percentile
Chlorophyll a	ug/l (1)	4.1	37	17
Total Phosphorus	mg/l as P (0.01)	0.005	31	<5
Total Nitrogen	mg/l as N (0.06)	1.88	82	79
Transparency (Secchi depth)	meters	2.00	64	85
Florida Trophic State Index		25	14	<5
Specific Conductance	S/cm at 25C (1)	227	69	56
pH	standard units (0.1)	7.9	78	67
Color	PtCo units (1)	8	24	8
Turbidity	NTU (1)	1.0	29	5
Total Alkalinity	mg/l as CaCO3 (1)	43	75	58
Hardness	mg/l as CaCO3 (0.02)	79	79	
Total Suspended Solids	mg/l (0.05)	1.2	33	
Ammonia	mg/l as N (0.03)	0.029	60	
Nitrate+Nitrite	mg/l as N (0.01)	0.738	94	
Total Kjeldahl Nitrogen	mg/l as N (0.06)	1.14	58	
Orthophosphorus	mg/l as P (0.01)	0.005	56	
Chloride	mg/l (0.05)	18	46	
Sulfate	mg/l (0.05)	33	82	
Sodium	mg/l (0.06)	5.1	13	
Potassium	mg/l (0.07)	8.3	87	
Calcium	mg/l (0.04)	12.5	51	
Magnesium	mg/l (0.006)	11.5	91	
Iron	ug/l (0.03)	18	16	

Based upon the average FTSI of 25, water quality is considered good. Fox Lake can be characterized as a clear (color<=10 color units), medium hard water, mesotrophic lake, with low concentrations of total phosphorus and high concentrations of total nitrogen. The chemical type of water (predominant ionic composition) is calcium sulfate.

Plots and Trends: No or insufficient data available for plotting or trend detection. Shown is a diagram of the relative ionic composition of the lake water.

MAJOR IONS (% meq/l)

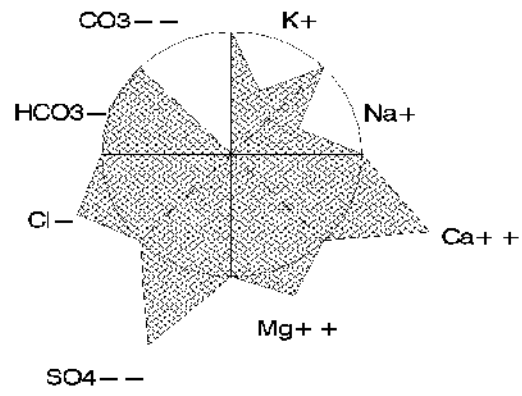

Lake Francis Highlands County

USGS Quadrangle: Lake June in Winter
 Section/Township/Range: 22-36S-29E
 Approx. Lake Center, Lat/Long: 272023/812422
 Surface Area: 539 acres
 Approx. Lake Elevation: 93 feet
 Average Depth: 11.2 feet
 Observed Maximum Depth: 19 feet
 (reference elevation 92.94 feet)
 Lake Type: inflow and outflow (type 3)
 Major Basin: Kissimmee Ridge
 Minor Basin: Lake Francis Outlet
 Lake Region: Southern Lake Wales Ridge
 Public Access: yes

Major Land Use/Land Cover (1990)
 within 500 meters of the lakeshore:
 - tree crops, typically citrus (41%)
 - medium density residential (27%)
 - stream and lake swamps (11%)

Total Number of Samples Collected: 10 Most Recent Sample Collected: April 1994

Parameter	Units (Detection Limit)	Average Value	District Percentile	Florida Percentile
Chlorophyll a	ug/l (1)	7.5	55	32
Total Phosphorus	mg/l as P (0.01)	0.015	53	8
Total Nitrogen	mg/l as N (0.06)	0.54	6	12
Transparency (Secchi depth)	meters	2.30	71	90
Florida Trophic State Index		37	45	11
Specific Conductance	S/cm at 25C (1)	159	42	44
pH	standard units (0.1)	7.1	38	35
Color	PtCo units (1)	4	<5	<5
Turbidity	NTU (1)	2.1	53	21
Total Alkalinity	mg/l as CaCO3 (1)	9	24	24
Hardness	mg/l as CaCO3 (0.02)	30	21	
Total Suspended Solids	mg/l (0.05)	3.8	71	
Ammonia	mg/l as N (0.03)	0.015	60	
Nitrate+Nitrite	mg/l as N (0.01)	0.020	51	
Total Kjeldahl Nitrogen	mg/l as N (0.06)	0.52	9	
Orthophosphorus	mg/l as P (0.01)	0.005	56	
Chloride	mg/l (0.05)	20	56	
Sulfate	mg/l (0.05)	6	23	
Sodium	mg/l (0.06)	5.8	20	
Potassium	mg/l (0.07)	3.5	50	
Calcium	mg/l (0.04)	5.3	15	
Magnesium	mg/l (0.006)	4.3	60	
Iron	ug/l (0.03)	13	7	

Based upon the average FTSI of 37, water quality is considered good. Lake Francis can be characterized as a clear (color<=10 color units), soft water, mesotrophic lake, with very low concentrations of total nitrogen. The chemical type of water (predominant ionic composition) is sodium sulfate (2 samples) or sodium chloride (1 sample).

Plots and Trends: Lake surface elevations demonstrated a decline for the first 20 years of the period of record. More recent records show stable lake levels fluctuating about the long-term median value (dashed line), though generally with a narrower range of annual fluctuation. Though changes in water chemistry are suggested by some of the plots, the record is interrupted and it is difficult to conclude if the changes are truly trends. Also shown is a diagram of the relative ionic composition of the lake water.

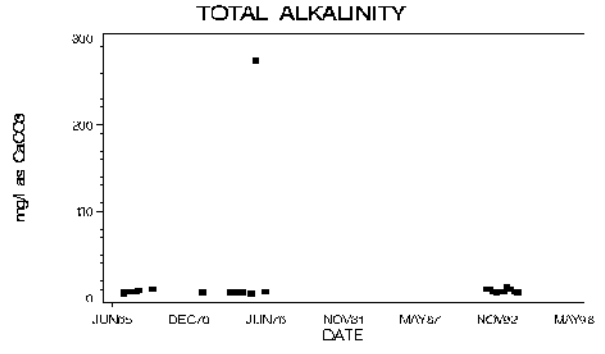
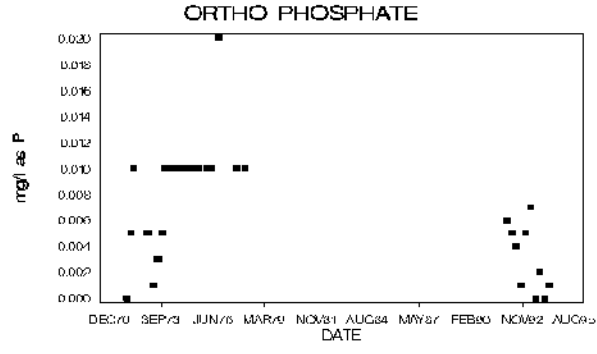
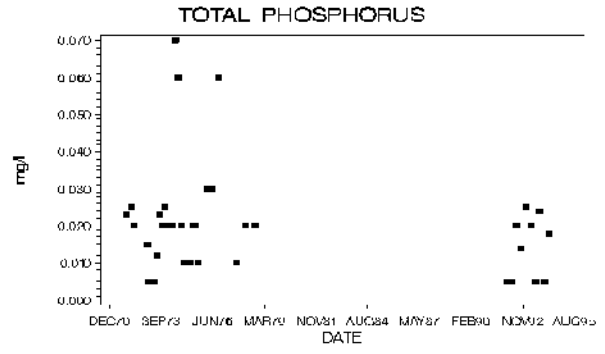
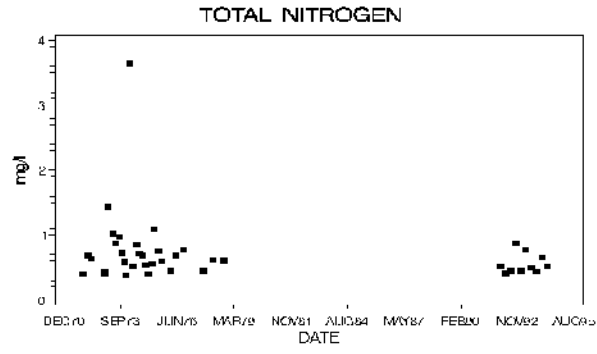
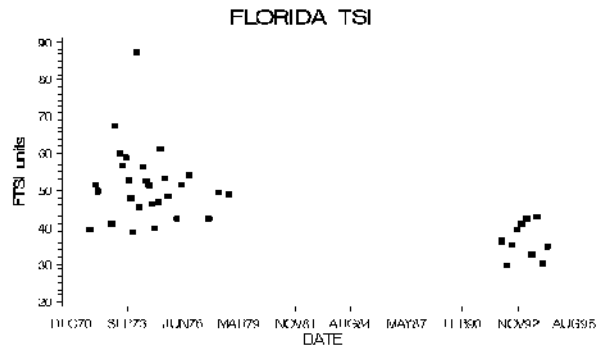
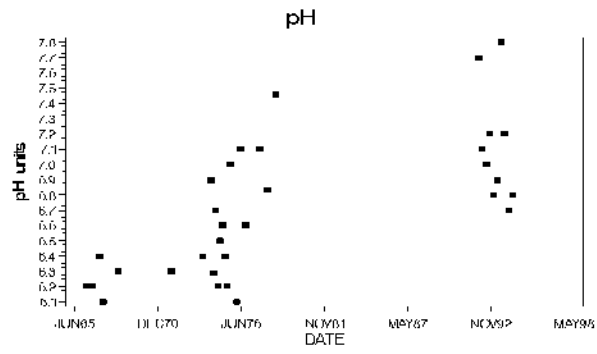
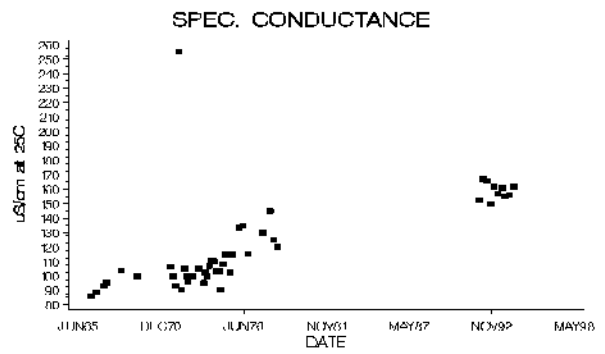
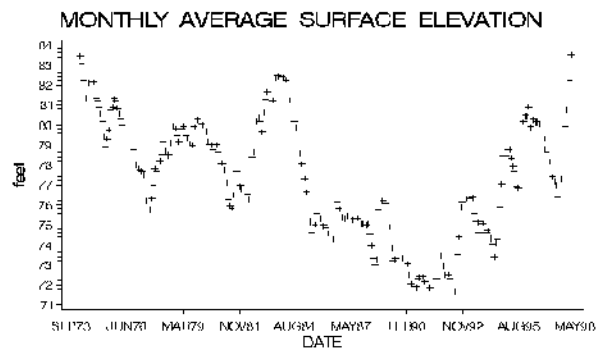

Lake Francis, Highlands County

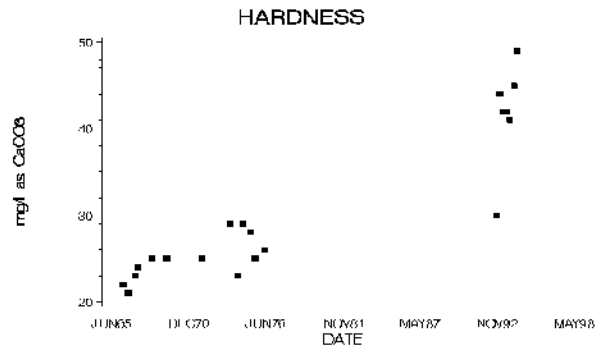
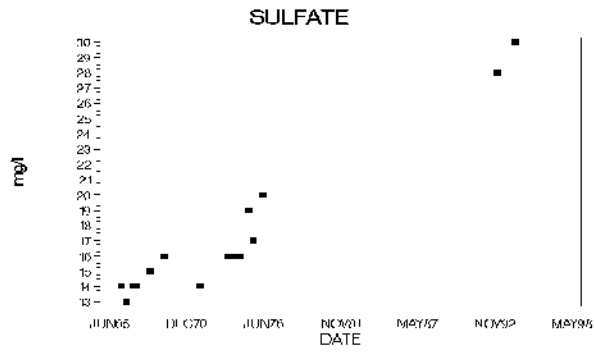
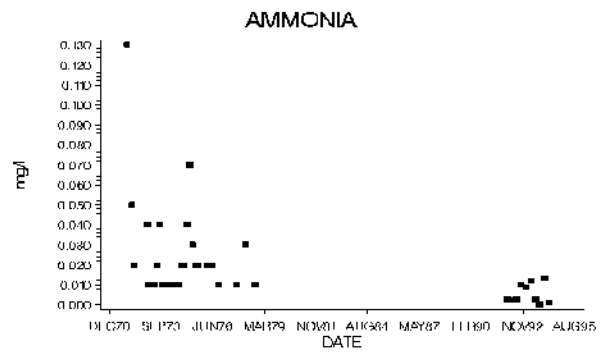
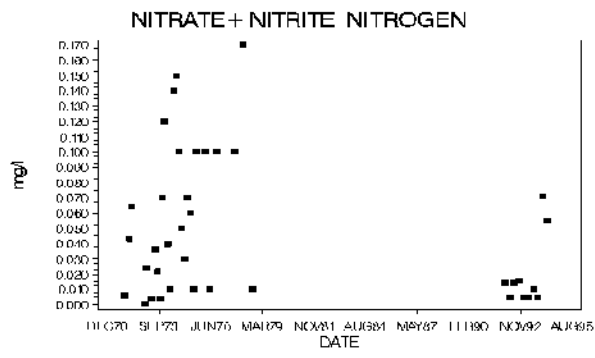

MAJOR IONS (% meq/l)

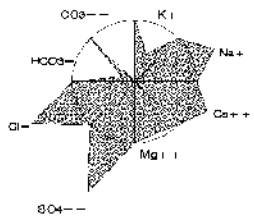

Lake Glenada Highlands County

USGS Quadrangle: Avon Park Major Land Use/Land Cover (1990)
 Section/Township/Range: 34-33S-28E within 500 meters of the lakeshore:
 Approx. Lake Center, Lat/Long: 273350/813022 - tree crops, typically citrus (37%)
 Surface Area: 177 acres - shrub and brushland range (11%)
 Approx. Lake Elevation: 120 feet - commercial and services (10%)
 Average Depth: 7.8 feet
 (reference elevation not given)
 Lake Type: inflow and outflow (type 3)
 Major Basin: Kissimmee Ridge
 Minor Basin: Carter Creek
 Lake Region: Lake Wales Ridge Transition
 Public Access: yes

Total Number of Samples Collected: 2 Most Recent Sample Collected: January 1995

Parameter	Units (Detection Limit)	Average Value	District Percentile	Florida Percentile
Chlorophyll a	ug/l (1)	40.7	92	75
Total Phosphorus	mg/l as P (0.01)	0.180	>95	82
Total Nitrogen	mg/l as N (0.06)	1.92	83	80
Transparency (Secchi depth)	meters	0.85	26	55
Florida Trophic State Index		68	93	75
Specific Conductance	S/cm at 25C (1)	219	66	55
pH	standard units (0.1)	8.2	85	75
Color	PtCo units (1)	45	76	35
Turbidity	NTU (1)	6.7	81	59
Total Alkalinity	mg/l as CaCO3 (1)	26	52	45
Hardness	mg/l as CaCO3 (0.02)	44	43	
Total Suspended Solids	mg/l (0.05)	6.3	83	
Ammonia	mg/l as N (0.03)	0.015	60	
Nitrate+Nitrite	mg/l as N (0.01)	0.005	33	
Total Kjeldahl Nitrogen	mg/l as N (0.06)	1.91	88	
Orthophosphorus	mg/l as P (0.01)	0.098	>95	
Chloride	mg/l (0.05)	31	87	
Sulfate	mg/l (0.05)	15	50	
Sodium	mg/l (0.06)	22.0	94	
Potassium	mg/l (0.07)	4.9	65	
Calcium	mg/l (0.04)	12.0	48	
Magnesium	mg/l (0.006)	3.2	48	
Iron	ug/l (0.03)	17	13	

Based upon the average FTSI of 68, water quality is considered fair. Lake Glenada can be characterized as a colored, soft water, eutrophic to hypereutrophic lake, with high concentrations of total phosphorus and high concentrations of total nitrogen. The chemical type of water (predominant ionic composition) is sodium chloride.

Also of note:

- The measured pH was high.

Plots and Trends: The lake surface elevation period of record for Lake Glenada is interrupted, and it is difficult to draw conclusions about its history. Lake levels during the past decade seem to be higher than in the earlier years of the record. Rising lake levels through the 1990s is consistent with changes in elevation observed for other lakes in this region of the Lake Wales Ridge. Also shown is a diagram of the relative ionic composition of the lake water.

MONTHLY AVERAGE SURFACE ELEVATION

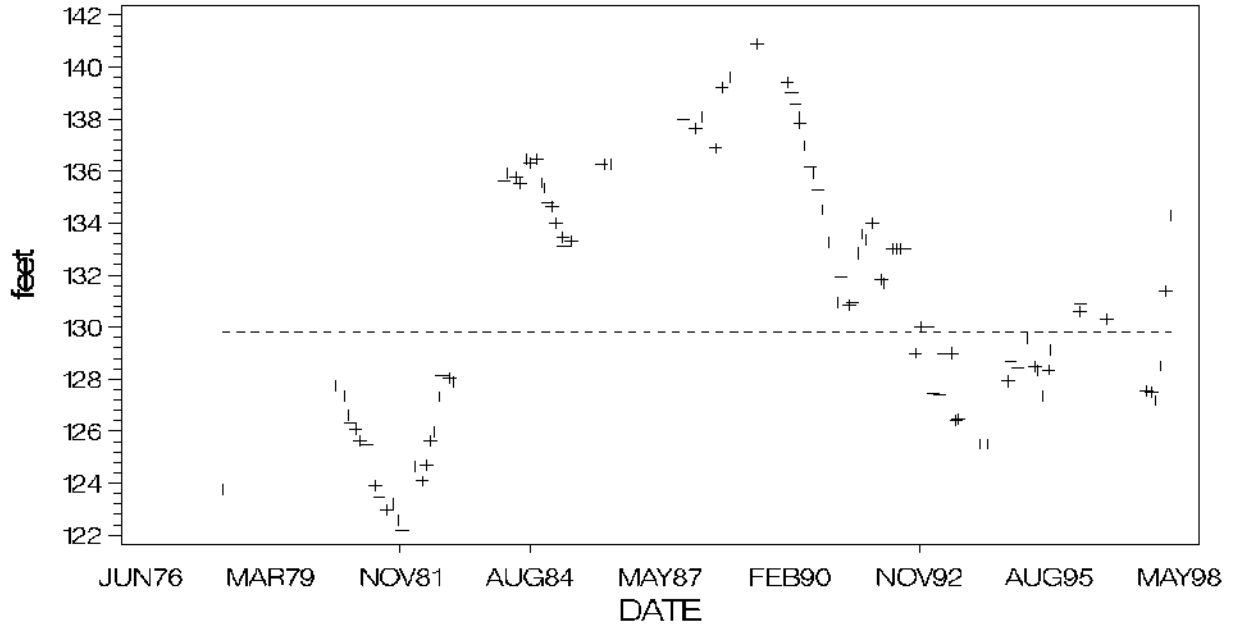

MAJOR IONS (% meq/l)

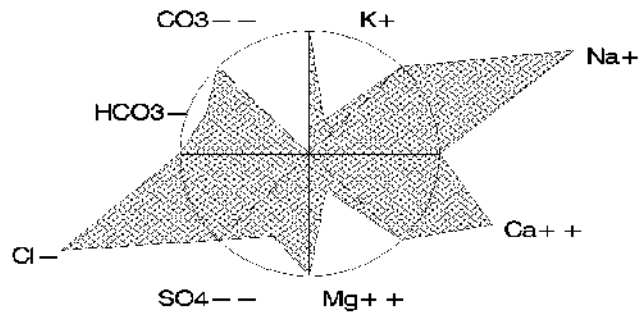

Grassy Lake Highlands County

USGS Quadrangle: Lake Placid Major Land Use/Land Cover (1990)
 Section/Township/Range: 21-37S-30E within 500 meters of the lakeshore:
 Approx. Lake Center, Lat/Long: 271432/811945 - medium density residential (29%)
 Surface Area: 517 acres - low density residential (18%)
 Approx. Lake Elevation: 94 feet - other open lands - rural (15%)
 Average Depth: 6.7 feet
 Observed Maximum Depth: 19 feet
 (reference elevation 93.5 feet)
 Lake Type: outflow (type 2)
 Major Basin: Kissimmee Ridge
 Minor Basin: Grassy Creek
 Lake Region: Southern Lake Wales Ridge

Total Number of Samples Collected: 2 Most Recent Sample Collected: January 1996

Parameter	Units (Detection Limit)	Average Value	District Percentile	Florida Percentile
Chlorophyll a	ug/l (1)	2.5	18	11
Total Phosphorus	mg/l as P (0.01)	0.005	31	<5
Total Nitrogen	mg/l as N (0.06)	1.01	41	34
Transparency (Secchi depth)	meters	3.00	84	>95
Florida Trophic State Index		26	16	<5
Specific Conductance	S/cm at 25C (1)	146	35	41
pH	standard units (0.1)	7.2	43	40
Color	PtCo units (1)	6	17	6
Turbidity	NTU (1)	0.9	28	<5
Total Alkalinity	mg/l as CaCO3 (1)	18	40	36
Hardness	mg/l as CaCO3 (0.02)	40	36	
Total Suspended Solids	mg/l (0.05)	3.8	71	
Ammonia	mg/l as N (0.03)	0.040	69	
Nitrate+Nitrite	mg/l as N (0.01)	0.053	71	
Total Kjeldahl Nitrogen	mg/l as N (0.06)	0.96	44	
Orthophosphorus	mg/l as P (0.01)	0.005	56	
Chloride	mg/l (0.05)	15	34	
Sulfate	mg/l (0.05)	23	67	
Sodium	mg/l (0.06)	7.8	42	
Potassium	mg/l (0.07)	4.8	64	
Calcium	mg/l (0.04)	9.7	38	
Magnesium	mg/l (0.006)	3.7	55	
Iron	ug/l (0.03)	30	38	

Based upon the average FTSI of 26, water quality is considered good. Grassy Lake can be characterized as a clear (color<=10 color units), soft water, oligo-mesotrophic lake, with low concentrations of total phosphorus. The chemical type of water (predominant ionic composition) is calcium sulfate.

Also of note:

- Melaleuca was observed on the lake shore.

Plots and Trends: The period of record for lake elevation in Grassy Lake is interrupted, however, present-day elevations are similar to elevations recorded at the beginning of the period of record. Chlorophyll a concentrations have remained low for the few samples collected from the lake. Also shown is a diagram of the relative ionic composition of the lake water.

MONTHLY AVERAGE SURFACE ELEVATION

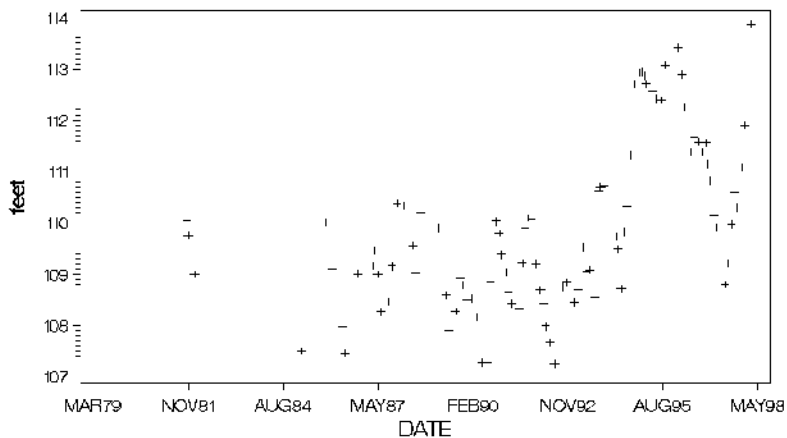

CHLOROPHYLL a

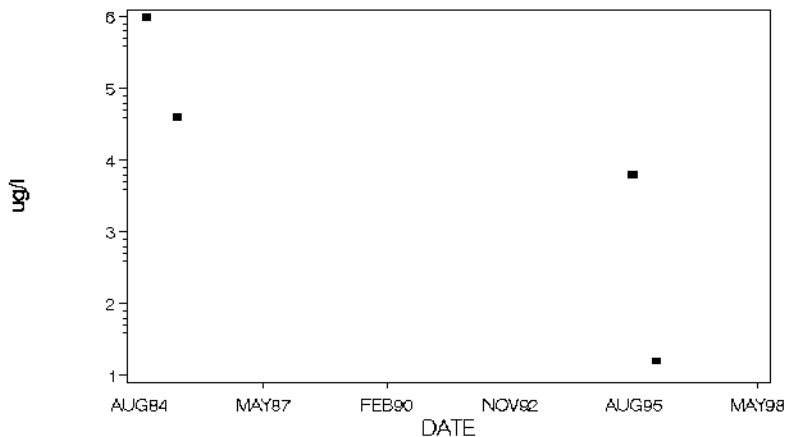

MAJOR IONS (% meq/l)

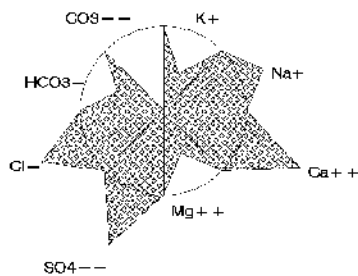

Grassy Lake, Highlands County

Grassy Pond Highlands County

USGS Quadrangle: Lake Arbuckle SW Major Land Use/Land Cover (1990)
 Section/Township/Range: 33-33S-29E within 500 meters of the lakeshore:
 Approx. Lake Center, Lat/Long: 273404/812503 - open land (53%)
 Surface Area: 100 acres - cropland and pastureland (23%)
 Approx. Lake Elevation: 103 feet - tree crops, typically citrus (12%)
 Lake Type: isolated (type 4)
 Major Basin: Kissimmee Ridge
 Minor Basin: Carter Creek
 Lake Region: Lake Wales Ridge Transition

Total Number of Samples Collected: 2 Most Recent Sample Collected: January 1996

Parameter	Units (Detection Limit)	Average Value	District Percentile	Florida Percentile
Chlorophyll a	ug/l (1)	2.6	19	11
Total Phosphorus	mg/l as P (0.01)	0.011	38	6
Total Nitrogen	mg/l as N (0.06)	1.81	79	76
Transparency (Secchi depth)	meters	0.30	<5	<5
Florida Trophic State Index		41	56	18
Specific Conductance	S/cm at 25C (1)	401	95	76
pH	standard units (0.1)	4.6	<5	<5
Color	PtCo units (1)	238	>95	>95
Turbidity	NTU (1)	8.9	85	66
Total Alkalinity	mg/l as CaCO3 (1)	2	<5	5
Hardness	mg/l as CaCO3 (0.02)	5	<5	
Total Suspended Solids	mg/l (0.05)	2.6	60	
Ammonia	mg/l as N (0.03)	0.564	>95	
Nitrate+Nitrite	mg/l as N (0.01)	0.026	57	
Total Kjeldahl Nitrogen	mg/l as N (0.06)	1.79	84	
Orthophosphorus	mg/l as P (0.01)	0.011	64	
Chloride	mg/l (0.05)	6	5	
Sulfate	mg/l (0.05)	2	10	
Sodium	mg/l (0.06)	3.5	5	
Potassium	mg/l (0.07)	0.3	7	
Calcium	mg/l (0.04)	1.1	<5	
Magnesium	mg/l (0.006)	0.5	<5	
Iron	ug/l (0.03)	273	95	

Based upon the average FTSI of 41, water quality is considered good. Grassy Pond can be characterized as a highly colored, soft water, oligo-mesotrophic lake, with high concentrations of total nitrogen. The chemical type of water (predominant ionic composition) is sodium chloride.

Also of note:

- The measured pH was very low.

Plots and Trends: No or insufficient data available for plotting or trend detection. Shown is a diagram of the relative ionic composition of the lake water.

MAJOR IONS (% meq/l)

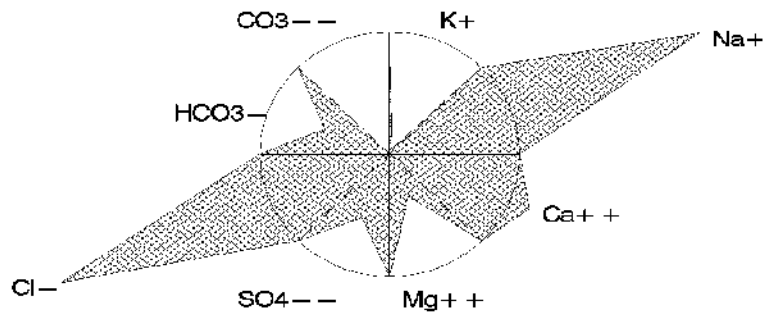

Grassy Pond, Highlands County

Lake Harry Highlands County

USGS Quadrangle: Lake Placid Major Land Use/Land Cover (1990)
 Section/Township/Range: 1-36S-29E within 500 meters of the lakeshore:
 Approx. Lake Center, Lat/Long: 272210/812227 - tree crops, typically citrus (73%)
 Surface Area: 12 acres - herbaceous range (6%)
 Approx. Lake Elevation: 68 feet - cropland and pastureland (6%)
 Lake Type: isolated (type 4)
 Major Basin: Kissimmee Ridge
 Minor Basin: Grassy Creek
 Lake Region: Southern Lake Wales Ridge

Total Number of Samples Collected: 2 Most Recent Sample Collected: February 1995

Parameter	Units (Detection Limit)	Average Value	District Percentile	Florida Percentile
Chlorophyll a	ug/l (1)	25.6	83	59
Total Phosphorus	mg/l as P (0.01)	0.005	31	<5
Total Nitrogen	mg/l as N (0.06)	2.04	85	82
Transparency (Secchi depth)	meters	0.70	18	40
Florida Trophic State Index		50	72	35
Specific Conductance	S/cm at 25C (1)	242	76	59
pH	standard units (0.1)	7.6	64	57
Color	PtCo units (1)	5	9	5
Turbidity	NTU (1)	10.6	89	71
Total Alkalinity	mg/l as CaCO3 (1)	26	52	45
Hardness	mg/l as CaCO3 (0.02)	88	85	
Total Suspended Solids	mg/l (0.05)	8.3	87	
Ammonia	mg/l as N (0.03)	0.269	>95	
Nitrate+Nitrite	mg/l as N (0.01)	0.224	87	
Total Kjeldahl Nitrogen	mg/l as N (0.06)	1.81	85	
Orthophosphorus	mg/l as P (0.01)	0.009	56	
Chloride	mg/l (0.05)	21	61	
Sulfate	mg/l (0.05)	52	93	
Sodium	mg/l (0.06)	7.0	33	
Potassium	mg/l (0.07)	7.0	81	
Calcium	mg/l (0.04)	19.0	72	
Magnesium	mg/l (0.006)	9.8	87	
Iron	ug/l (0.03)	24	29	

Based upon the average FTSI of 50, water quality is considered good. Lake Harry can be characterized as a clear (color<=10 color units), medium hard water, eutrophic lake, with low concentrations of total phosphorus and high concentrations of total nitrogen. The chemical type of water (predominant ionic composition) is calcium sulfate.

Plots and Trends: No or insufficient data available for plotting or trend detection. Shown is a diagram of the relative ionic composition of the lake water.

MAJOR IONS (% meq/l)

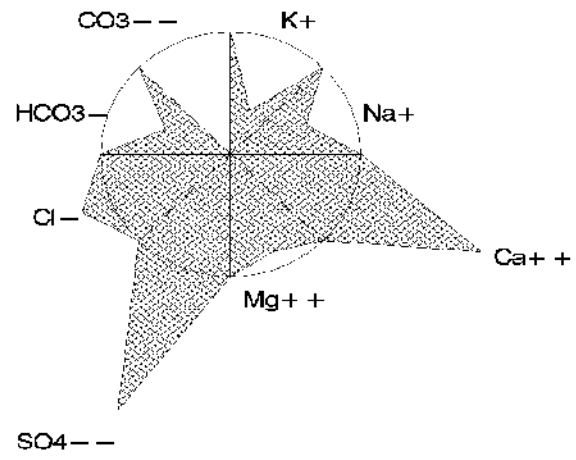

Lake Harry, Highlands County

Lake Henry

Highlands County

USGS Quadrangle: Lake June-in-Winter
 Section/Township/Range: 25-36S-29E
 Approx. Lake Center, Lat/Long: 271924/812302
 Surface Area: 64 acres
 Approx. Lake Elevation: 76 feet
 Lake Type: outflow (type 2)
 Major Basin: Kissimmee Ridge
 Minor Basin: Lake Francis Outlet
 Lake Region: Southern Lake Wales Ridge
 Public Access: yes

Major Land Use/Land Cover (1990)
 within 500 meters of the lakeshore:
 - medium density residential (66%)
 - tree crops, typically citrus (16%)
 - hardwood - conifer mixed (13%)

Total Number of Samples Collected: 2 Most Recent Sample Collected: January 1995

Parameter	Units (Detection Limit)	Average Value	District Percentile	Florida Percentile
Chlorophyll a	ug/l (1)	3.0	25	13
Total Phosphorus	mg/l as P (0.01)	0.010	33	5
Total Nitrogen	mg/l as N (0.06)	0.69	16	20
Transparency (Secchi depth)	meters	3.00	84	>95
Florida Trophic State Index		29	23	<5
Specific Conductance	S/cm at 25C (1)	159	42	44
pH	standard units (0.1)	7.1	38	35
Color	PtCo units (1)	5	9	5
Turbidity	NTU (1)	0.5	28	<5
Total Alkalinity	mg/l as CaCO3 (1)	8	21	22
Hardness	mg/l as CaCO3 (0.02)	40	36	
Total Suspended Solids	mg/l (0.05)	1.2	33	
Ammonia	mg/l as N (0.03)	0.015	60	
Nitrate+Nitrite	mg/l as N (0.01)	0.022	54	
Total Kjeldahl Nitrogen	mg/l as N (0.06)	0.67	22	
Orthophosphorus	mg/l as P (0.01)	0.010	59	
Chloride	mg/l (0.05)	19	51	
Sulfate	mg/l (0.05)	28	74	
Sodium	mg/l (0.06)	8.2	46	
Potassium	mg/l (0.07)	5.1	66	
Calcium	mg/l (0.04)	6.8	23	
Magnesium	mg/l (0.006)	5.6	74	
Iron	ug/l (0.03)	19	17	

Based upon the average FTSI of 29, water quality is considered good. Lake Henry can be characterized as a clear (color<=10 color units), soft water, oligotrophic lake. The chemical type of water (predominant ionic composition) is sodium sulfate (2 samples) or calcium sulfate (1 sample).

Plots and Trends: No or insufficient data available for plotting or trend detection. Shown is a diagram of the relative ionic composition of the lake water.

MAJOR IONS (% meq/l)

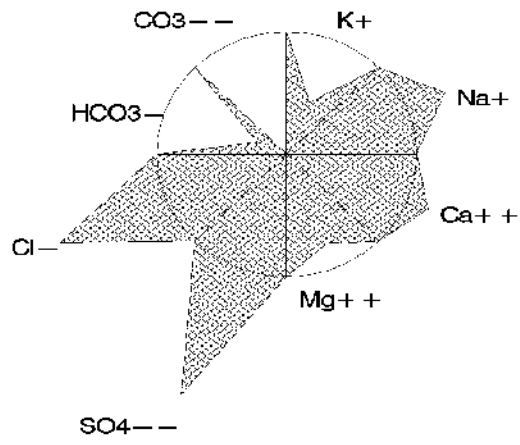

Lake Hill

Highlands County

USGS Quadrangle: Lake June-in-Winter
 Section/Township/Range: 17-36S-29E
 Approx. Lake Center, Lat/Long: 272059/812619
 Surface Area: 70 acres
 Approx. Lake Elevation: 99 feet
 Average Depth: 8.5 feet
 Observed Maximum Depth: 19 feet
 (reference elevation 92.94 feet)
 Lake Type: isolated (type 4)
 Major Basin: Kissimmee Ridge
 Minor Basin: Josephine Creek
 Lake Region: Lake Wales Ridge Transition
 Public Access: yes

Major Land Use/Land Cover (1990)
 within 500 meters of the lakeshore:
 - open land (80%)
 - shrub and brushland range (7%)
 - pine flatwoods (5%)

Total Number of Samples Collected: 3 Most Recent Sample Collected: January 1995

Parameter	Units (Detection Limit)	Average Value	District Percentile	Florida Percentile
Chlorophyll a	ug/l (1)	1.8	10	7
Total Phosphorus	mg/l as P (0.01)	0.009	31	<5
Total Nitrogen	mg/l as N (0.06)	1.08	47	36
Transparency (Secchi depth)	meters	3.70	92	>95
Florida Trophic State Index		23	11	<5
Specific Conductance	S/cm at 25C (1)	50	<5	5
pH	standard units (0.1)	5.3	<5	<5
Color	PtCo units (1)	17	48	15
Turbidity	NTU (1)	0.7	28	<5
Total Alkalinity	mg/l as CaCO3 (1)	5	13	13
Hardness	mg/l as CaCO3 (0.02)	8	<5	
Total Suspended Solids	mg/l (0.05)	0.5	11	
Ammonia	mg/l as N (0.03)	0.025	60	
Nitrate+Nitrite	mg/l as N (0.01)	0.012	40	
Total Kjeldahl Nitrogen	mg/l as N (0.06)	1.07	53	
Orthophosphorus	mg/l as P (0.01)	0.008	56	
Chloride	mg/l (0.05)	7	7	
Sulfate	mg/l (0.05)	4	17	
Sodium	mg/l (0.06)	3.6	6	
Potassium	mg/l (0.07)	0.3	7	
Calcium	mg/l (0.04)	1.8	<5	
Magnesium	mg/l (0.006)	0.7	<5	
Iron	ug/l (0.03)	20	21	

Based upon the average FTSI of 23, water quality is considered good. Lake Hill can be characterized as a clear to moderately colored (10<color<20 color units), soft water, oligotrophic lake, with low concentrations of total phosphorus. The chemical type of water (predominant ionic composition) is sodium chloride.

Also of note:

- The measured pH was low.

Plots and Trends: No or insufficient data available for plotting or trend detection. Shown is a diagram of the relative ionic composition of the lake water.

MAJOR IONS (% meq/l)

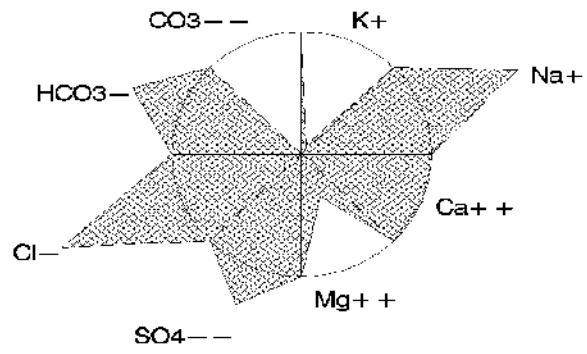

Hog Lake (Granada)

Highlands County

USGS Quadrangle: Avon Park Major Land Use/Land Cover (1990)
 Section/Township/Range: 9-34S-28E within 500 meters of the lakeshore:
 Approx. Lake Center, Lat/Long: 273149/813104 - recreational (36%)
 Surface Area: 31 acres - high density residential (21%)
 Approx. Lake Elevation: 161 feet - open land (12%)
 Lake Type: outflow (type 2)
 Major Basin: Peace River
 Minor Basin: Hog Lake Outlet
 Lake Region: Lake Wales Ridge Transition

Total Number of Samples Collected: 2 Most Recent Sample Collected: February 1995

Parameter	Units (Detection Limit)	Average Value	District Percentile	Florida Percentile
Chlorophyll a	ug/l (1)	2.8	22	12
Total Phosphorus	mg/l as P (0.01)	0.010	33	5
Total Nitrogen	mg/l as N (0.06)	2.14	86	83
Transparency (Secchi depth)	meters	2.13	69	87
Florida Trophic State Index		31	29	6
Specific Conductance	S/cm at 25C (1)	150	39	42
pH	standard units (0.1)	6.8	25	25
Color	PtCo units (1)	18	51	15
Turbidity	NTU (1)	1.5	41	13
Total Alkalinity	mg/l as CaCO3 (1)	49	79	62
Hardness	mg/l as CaCO3 (0.02)	63	65	
Total Suspended Solids	mg/l (0.05)	1.8	47	
Ammonia	mg/l as N (0.03)	0.028	60	
Nitrate+Nitrite	mg/l as N (0.01)	0.043	67	
Total Kjeldahl Nitrogen	mg/l as N (0.06)	2.10	91	
Orthophosphorus	mg/l as P (0.01)	0.010	59	
Chloride	mg/l (0.05)	10	15	
Sulfate	mg/l (0.05)	6	23	
Sodium	mg/l (0.06)	5.3	15	
Potassium	mg/l (0.07)	1.4	24	
Calcium	mg/l (0.04)	15.0	60	
Magnesium	mg/l (0.006)	6.2	77	
Iron	ug/l (0.03)	66	70	

Based upon the average FTSI of 31, water quality is considered good. Hog Lake (Granada) can be characterized as a clear to moderately colored (10<color<20 color units), medium hard water, oligo-mesotrophic lake, with high concentrations of total nitrogen. The chemical type of water (predominant ionic composition) is calcium bicarbonate.

Plots and Trends: No or insufficient data available for plotting or trend detection. Shown is a diagram of the relative ionic composition of the lake water.

MAJOR IONS (% meq/l)

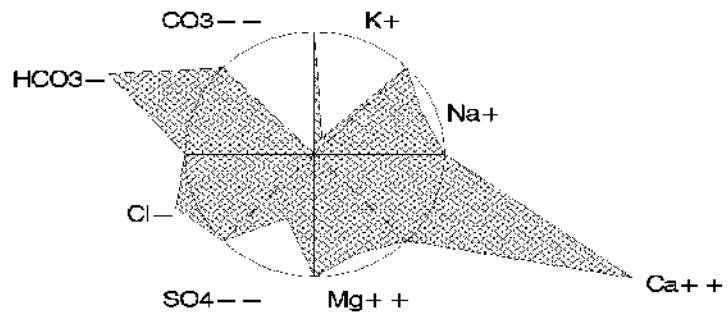

Hog Lake (Granada), Highlands County

Huckleberry Lake

Highlands County

USGS Quadrangle: Sebring Major Land Use/Land Cover (1990)
 Section/Township/Range: 7-35S-29E within 500 meters of the lakeshore:
 Approx. Lake Center, Lat/Long: 272710/812751 - pine flatwoods (28%)
 Surface Area: 119 acres - open land (19%)
 Approx. Lake Elevation: 105 feet - low density residential (18%)
 Lake Type: outflow (type 2)
 Major Basin: Kissimmee Ridge
 Minor Basin: Huckleberry Lake Outlet
 Lake Region: Lake Wales Ridge Transition

Total Number of Samples Collected: 2 Most Recent Sample Collected: February 1995

Parameter	Units (Detection Limit)	Average Value	District Percentile	Florida Percentile
Chlorophyll a	ug/l (1)	5.2	45	21
Total Phosphorus	mg/l as P (0.01)	0.226	>95	85
Total Nitrogen	mg/l as N (0.06)	0.37	<5	<5
Transparency (Secchi depth)	meters	1.60	52	78
Florida Trophic State Index		35	42	9
Specific Conductance	S/cm at 25C (1)	80	8	15
pH	standard units (0.1)	5.8	<5	6
Color	PtCo units (1)	138	93	88
Turbidity	NTU (1)	1.1	32	7
Total Alkalinity	mg/l as CaCO3 (1)	3	7	8
Hardness	mg/l as CaCO3 (0.02)	17	7	
Total Suspended Solids	mg/l (0.05)	0.7	18	
Ammonia	mg/l as N (0.03)	0.015	60	
Nitrate+Nitrite	mg/l as N (0.01)	0.049	69	
Total Kjeldahl Nitrogen	mg/l as N (0.06)	0.32	<5	
Orthophosphorus	mg/l as P (0.01)	0.201	>95	
Chloride	mg/l (0.05)	12	23	
Sulfate	mg/l (0.05)	9	34	
Sodium	mg/l (0.06)	7.1	34	
Potassium	mg/l (0.07)	1.6	27	
Calcium	mg/l (0.04)	4.7	13	
Magnesium	mg/l (0.006)	1.3	12	
Iron	ug/l (0.03)	95	80	

Based upon the average FTSI of 35, water quality is considered good. Huckleberry Lake can be characterized as a highly colored, soft water, mesotrophic lake, with high concentrations of total phosphorus, very low concentrations of total nitrogen. The chemical type of water (predominant ionic composition) is sodium chloride.

Also of note:

- The measured pH was low.

Plots and Trends: Lake surface elevations have been relatively stable over the short period of record. Also shown is a diagram of the relative ionic composition of the lake water.

MONTHLY AVERAGE SURFACE ELEVATION

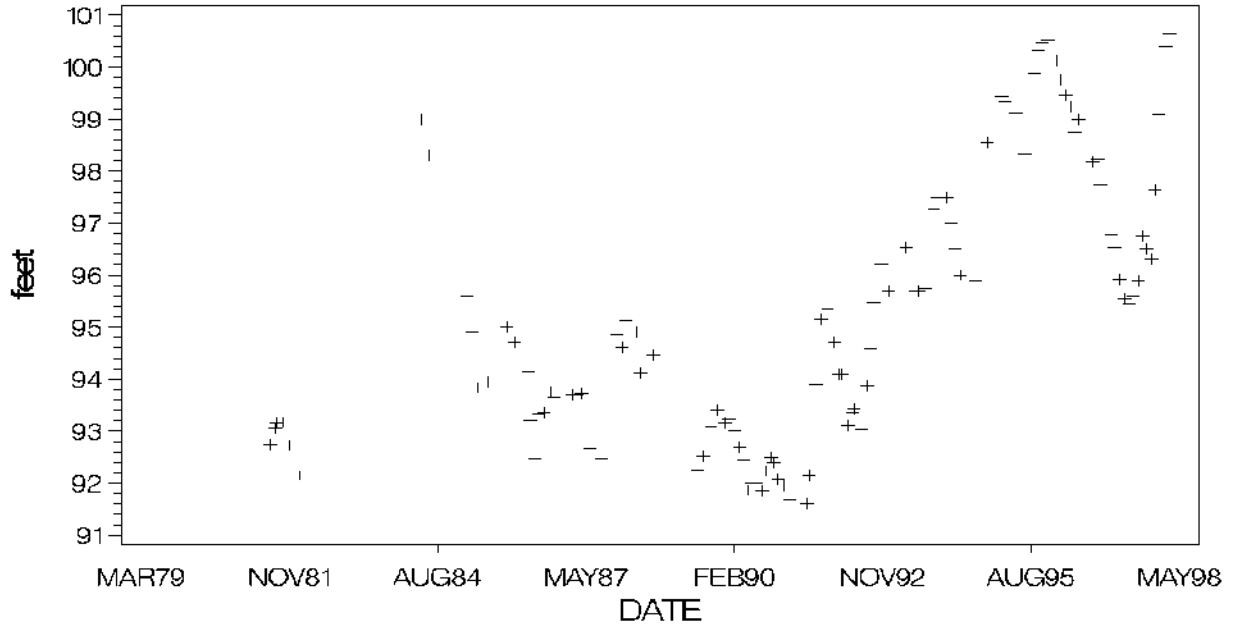

MAJOR IONS (% meq/l)

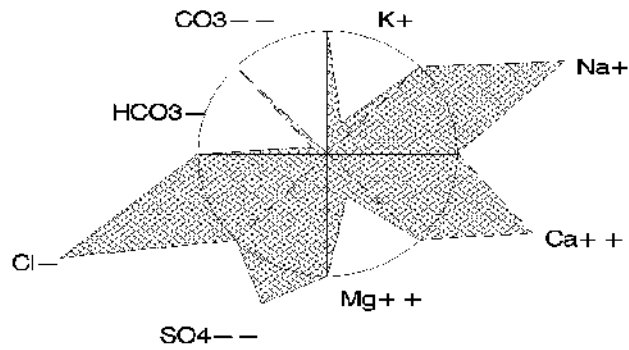

Lake Huntley Highlands County

USGS Quadrangle: Lake Placid Major Land Use/Land Cover (1990)
 Section/Township/Range: 5-37S-30E within 500 meters of the lakeshore:
 Approx. Lake Center, Lat/Long: 271711/812035 - tree crops, typically citrus (18%)
 Surface Area: 564 acres - medium density residential (15%)
 Approx. Lake Elevation: 84 feet - other open lands - rural (13%)
 Average Depth: 8.2 feet
 Observed Maximum Depth: 17 feet
 (reference elevation 83.9 feet)
 Lake Type: inflow and outflow (type 3)
 Major Basin: Kissimmee Ridge
 Minor Basin: Grassy Creek
 Lake Region: Southern Lake Wales Ridge
 Public Access: yes

Total Number of Samples Collected: 2 Most Recent Sample Collected: January 1996

Parameter	Units (Detection Limit)	Average Value	District Percentile	Florida Percentile
Chlorophyll a	ug/l (1)	5.0	44	20
Total Phosphorus	mg/l as P (0.01)	0.015	53	8
Total Nitrogen	mg/l as N (0.06)	0.43	<5	7
Transparency (Secchi depth)	meters	1.28	44	72
Florida Trophic State Index		38	49	13
Specific Conductance	S/cm at 25C (1)	150	39	42
pH	standard units (0.1)	6.2	8	10
Color	PtCo units (1)	5	9	5
Turbidity	NTU (1)	2.5	58	26
Total Alkalinity	mg/l as CaCO3 (1)	1	<5	<5
Hardness	mg/l as CaCO3 (0.02)	30	21	
Total Suspended Solids	mg/l (0.05)	2.4	57	
Ammonia	mg/l as N (0.03)	0.028	60	
Nitrate+Nitrite	mg/l as N (0.01)	0.175	86	
Total Kjeldahl Nitrogen	mg/l as N (0.06)	0.27	<5	
Orthophosphorus	mg/l as P (0.01)	0.010	59	
Chloride	mg/l (0.05)	21	61	
Sulfate	mg/l (0.05)	29	75	
Sodium	mg/l (0.06)	12.0	69	
Potassium	mg/l (0.07)	5.9	72	
Calcium	mg/l (0.04)	4.1	9	
Magnesium	mg/l (0.006)	4.8	66	
Iron	ug/l (0.03)	63	70	

Based upon the average FTSI of 38, water quality is considered good. Lake Huntley can be characterized as a clear (color<=10 color units), soft water, mesotrophic lake, with very low concentrations of total nitrogen. The chemical type of water (predominant ionic composition) is sodium sulfate.

Plots and Trends: There is a large gap in the period of record for Lake Huntley, however, lake levels in the 1980s and 1990s are comparable to those recorded in the 1950s and 1960s. There are no trends in the available data for total phosphorus or Chlorophyll a, however, historical concentrations of total phosphorus have been quite high, ranging between 0.020 and 0.070 mg/l. More recent measures of total P ranged between 0.014 and 0.025 mg/l. Also shown is a diagram of the relative ionic composition of the lake water.

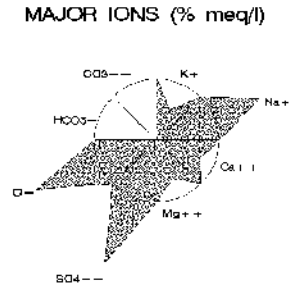
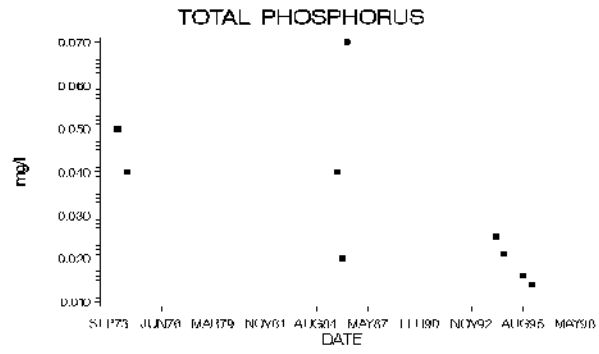
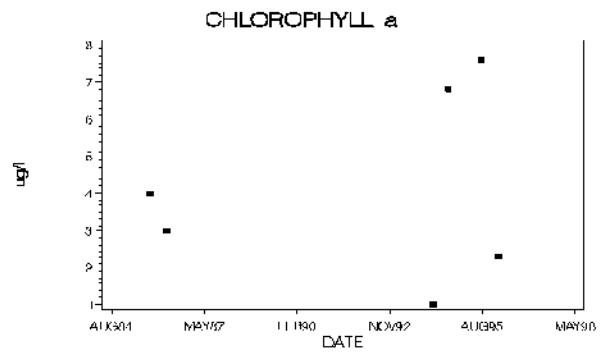
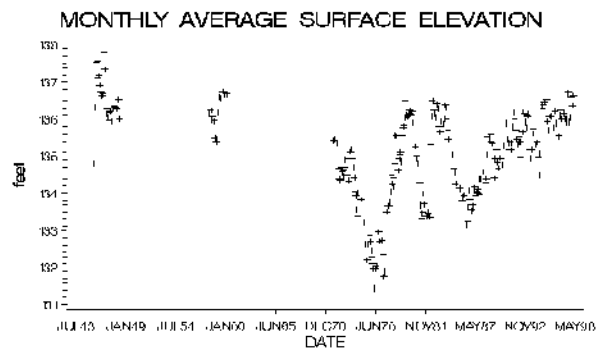

Lake Huntley, Highlands County

Lake Isis

Highlands County

USGS Quadrangle: Avon Park Major Land Use/Land Cover (1990)
 Section/Township/Range: 15-33S-28E within 500 meters of the lakeshore:
 Approx. Lake Center, Lat/Long: 273642/813039 - tree crops, typically citrus (36%)
 Surface Area: 53 acres - medium density residential (33%)
 Approx. Lake Elevation: 115 feet - industrial (12%)
 Lake Type: isolated (type 4)
 Major Basin: Kissimmee Ridge
 Minor Basin: Grassy Creek
 Lake Region: Southern Lake Wales Ridge

Total Number of Samples Collected: 2 Most Recent Sample Collected: January 1995

Parameter	Units (Detection Limit)	Average Value	District Percentile	Florida Percentile
Chlorophyll a	ug/l (1)	1.2	<5	<5
Total Phosphorus	mg/l as P (0.01)	0.015	53	8
Total Nitrogen	mg/l as N (0.06)	4.36	>95	>95
Transparency (Secchi depth)	meters	8.05	>95	>95
Florida Trophic State Index		17	<5	<5
Specific Conductance	S/cm at 25C (1)	228	70	56
pH	standard units (0.1)	6.9	29	28
Color	PtCo units (1)	5	9	5
Turbidity	NTU (1)	0.5	28	<5
Total Alkalinity	mg/l as CaCO3 (1)	21	43	40
Hardness	mg/l as CaCO3 (0.02)	82	82	
Total Suspended Solids	mg/l (0.05)	0.4	8	
Ammonia	mg/l as N (0.03)	0.015	60	
Nitrate+Nitrite	mg/l as N (0.01)	2.968	>95	
Total Kjeldahl Nitrogen	mg/l as N (0.06)	1.39	74	
Orthophosphorus	mg/l as P (0.01)	0.014	76	
Chloride	mg/l (0.05)	14	30	
Sulfate	mg/l (0.05)	43	90	
Sodium	mg/l (0.06)	5.0	12	
Potassium	mg/l (0.07)	7.3	83	
Calcium	mg/l (0.04)	14.5	58	
Magnesium	mg/l (0.006)	11.0	90	
Iron	ug/l (0.03)	13	7	

Based upon the average FTSI of 17, water quality is considered good. Lake Isis can be characterized as a clear (color<=10 color units), medium hard water, oligotrophic lake, with high concentrations of total nitrogen, and very high nitrate concentrations. The chemical type of water (predominant ionic composition) is calcium sulfate.

Plots and Trends: No or insufficient data available for plotting or trend detection. Shown is a diagram of the relative ionic composition of the lake water.

MAJOR IONS (% meq/l)

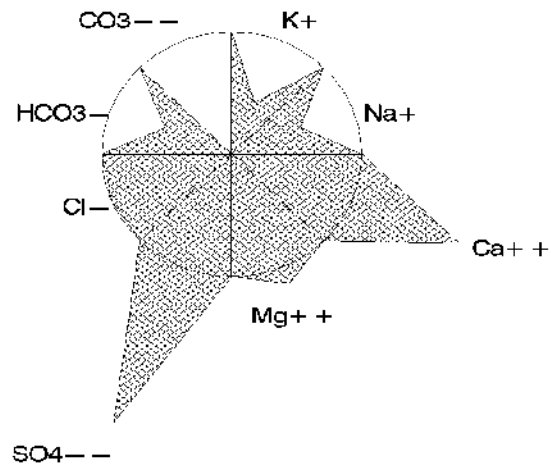

Lake Jackson

Highlands County

USGS Quadrangle: Sebring Major Land Use/Land Cover (1990)
 Section/Township/Range: 30-34S-29E within 500 meters of the lakeshore:
 Approx. Lake Center, Lat/Long: 272954/812738 - medium density residential (43%)
 Surface Area: 3412 acres - commercial and services (14%)
 Approx. Lake Elevation: 103 feet - freshwater marshes (12%)
 Average Depth: 12.5 feet
 Observed Maximum Depth: 22 feet
 (reference elevation 101 feet)
 Lake Type: inflow and outflow (type 3)
 Major Basin: Kissimmee Ridge
 Minor Basin: Josephine Creek
 Lake Region: Southern Lake Wales Ridge
 Public Access: yes

Total Number of Samples Collected: 18 Most Recent Sample Collected: April 1994

Parameter	Units (Detection Limit)	Average Value	District Percentile	Florida Percentile
Chlorophyll a	ug/l (1)	1.9	11	8
Total Phosphorus	mg/l as P (0.01)	0.014	50	7
Total Nitrogen	mg/l as N (0.06)	0.48	<5	9
Transparency (Secchi depth)	meters	3.39	89	>95
Florida Trophic State Index		26	17	<5
Specific Conductance	S/cm at 25C (1)	126	23	34
pH	standard units (0.1)	6.6	18	20
Color	PtCo units (1)	6	17	6
Turbidity	NTU (1)	0.7	28	<5
Total Alkalinity	mg/l as CaCO3 (1)	3	7	8
Hardness	mg/l as CaCO3 (0.02)	18	8	
Total Suspended Solids	mg/l (0.05)	1.0	28	
Ammonia	mg/l as N (0.03)	0.015	60	
Nitrate+Nitrite	mg/l as N (0.01)	0.014	42	
Total Kjeldahl Nitrogen	mg/l as N (0.06)	0.47	8	
Orthophosphorus	mg/l as P (0.01)	0.005	56	
Chloride	mg/l (0.05)	18	46	
Sulfate	mg/l (0.05)	5	20	
Sodium	mg/l (0.06)	6.6	29	
Potassium	mg/l (0.07)	1.9	32	
Calcium	mg/l (0.04)	3.6	7	
Magnesium	mg/l (0.006)	2.4	35	
Iron	ug/l (0.03)	10	<5	

Based upon the average FTSI of 26, water quality is considered good. Lake Jackson can be characterized as a clear (color<=10 color units), soft water, oligotrophic lake, with very low concentrations of total nitrogen. The chemical type of water (predominant ionic composition) is sodium chloride.

Plots and Trends: Lake Jackson has a long period of record for lake surface elevation. Elevations were relatively stable and high for the period from 1945 through the 1960s. Thereafter, the lake fluctuated over a larger range and was generally lower than the first half of the record. Florida TSI, calculated from total P and total N when no data were available for Chlorophyll a, represents the potential for productivity. The plot of FTSI shows a general decline (improvement) since the 1970s, though total N and total P have fluctuated widely. Specific conductance demonstrates an increase over time. Lake pH has fluctuated between acidic (pH<6.0) to moderately alkaline (pH>7.0), but there is no trend. Also shown is a diagram of the relative ionic composition of the lake water.

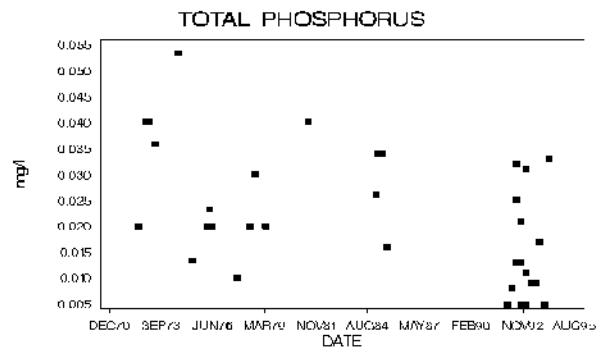
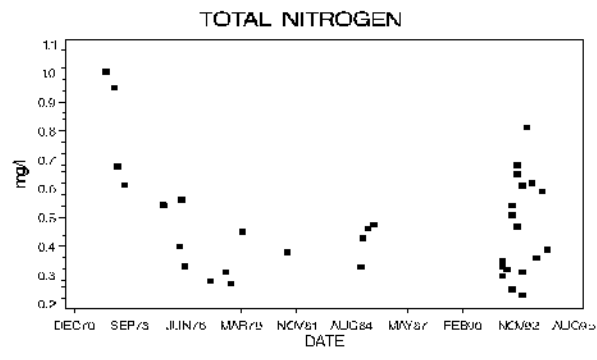
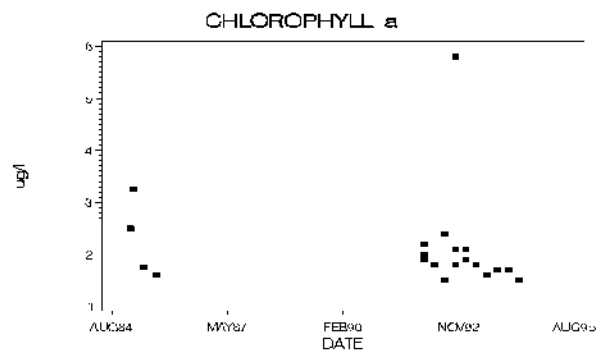
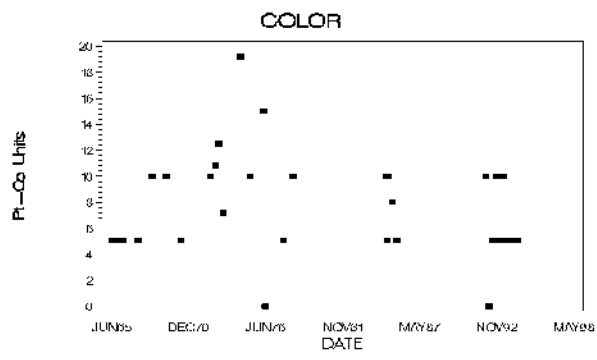
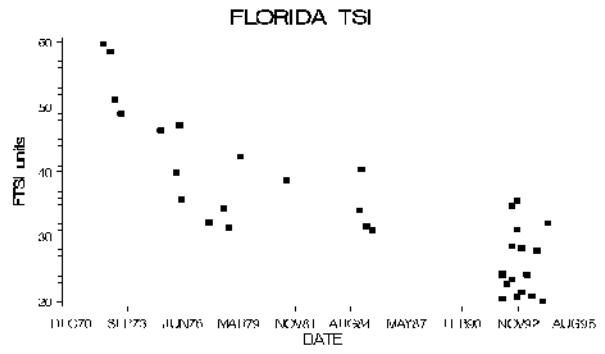
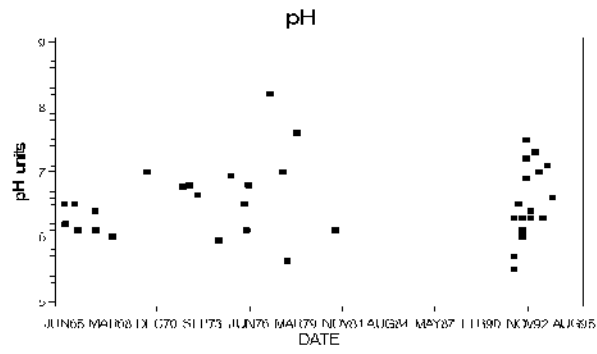
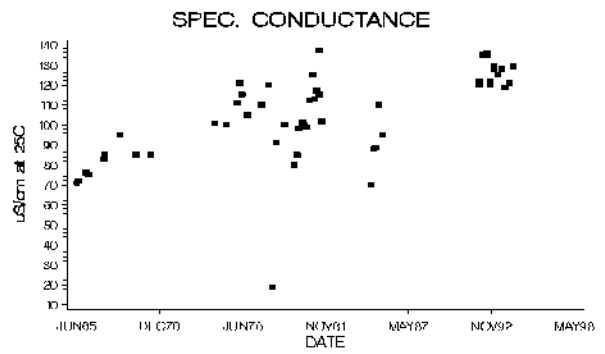
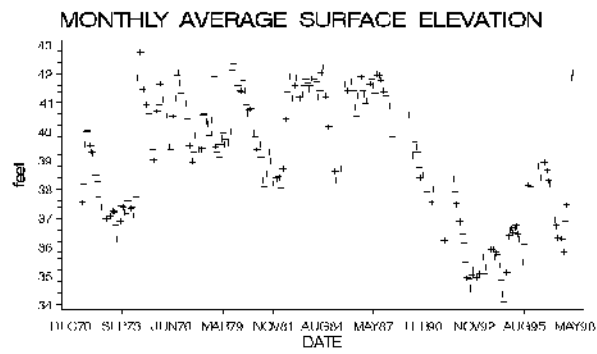

Lake Jackson, Highlands County

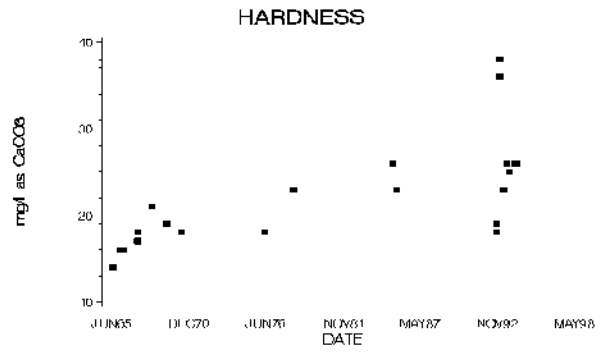
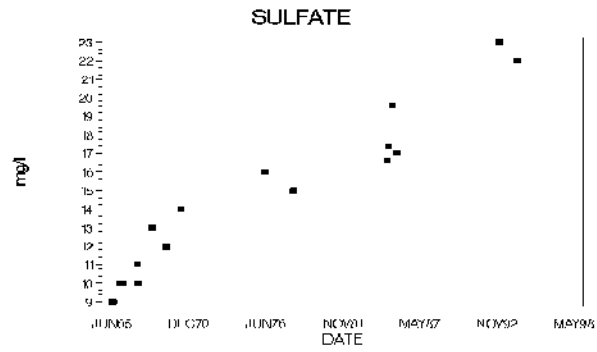
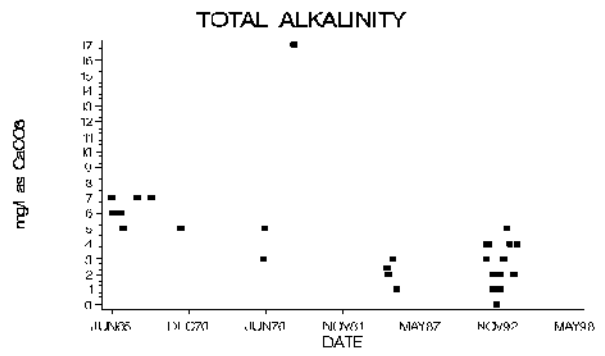
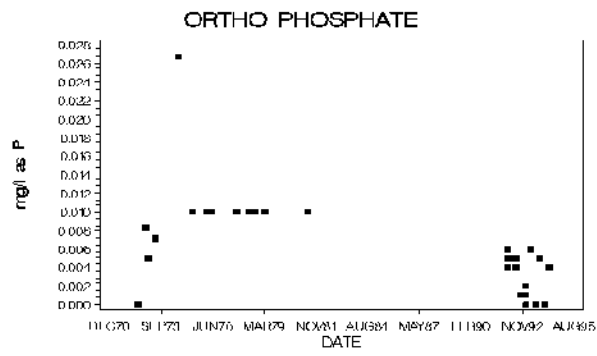

MAJOR IONS (% meq/l)

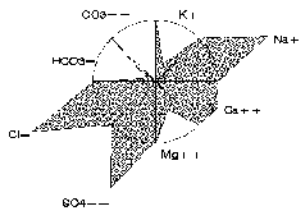

Lake Josephine Center Highlands County

USGS Quadrangle:	Sebring	Major Land Use/Land Cover (1990)
Section/Township/Range:	32-35S-29E	within 500 meters of the lakeshore:
Approx. Lake Center, Lat/Long:	272333/812624	- low density residential (38%)
Surface Area:	199 acres	- freshwater marshes (19%)
Approx. Lake Elevation:	73 feet	- stream and lake swamps (16%)
Average Depth: 4.3 feet		
Observed Maximum Depth: 5 feet		
(reference elevation 71 feet)		
Lake Type: inflow and outflow (type 3)		
Major Basin: Kissimmee Ridge		
Minor Basin: Josephine Creek		
Lake Region: Lake Wales Ridge Transition		
Public Access: yes		

Total Number of Samples Collected: 2 Most Recent Sample Collected: January 1996

Parameter	Units (Detection Limit)	Average Value	District Percentile	Florida Percentile
Chlorophyll a	ug/l (1)	17.7	77	49
Total Phosphorus	mg/l as P (0.01)	0.032	79	22
Total Nitrogen	mg/l as N (0.06)	1.20	55	40
Transparency (Secchi depth)	meters	0.30	<5	<5
Florida Trophic State Index		62	85	59
Specific Conductance	S/cm at 25C (1)	80	8	15
pH	standard units (0.1)	6.4	12	15
Color	PtCo units (1)	130	92	86
Turbidity	NTU (1)	4.2	71	43
Total Alkalinity	mg/l as CaCO3 (1)	8	21	22
Hardness	mg/l as CaCO3 (0.02)	21	10	
Total Suspended Solids	mg/l (0.05)	5.1	79	
Ammonia	mg/l as N (0.03)	0.054	78	
Nitrate+Nitrite	mg/l as N (0.01)	0.005	33	
Total Kjeldahl Nitrogen	mg/l as N (0.06)	1.20	62	
Orthophosphorus	mg/l as P (0.01)	0.011	64	
Chloride	mg/l (0.05)	13	27	
Sulfate	mg/l (0.05)	7	27	
Sodium	mg/l (0.06)	6.9	32	
Potassium	mg/l (0.07)	1.5	25	
Calcium	mg/l (0.04)	5.3	15	
Magnesium	mg/l (0.006)	1.9	23	
Iron	ug/l (0.03)	206	92	

Based upon the average FTSI of 62, water quality is considered fair. Lake Josephine Center can be characterized as a highly colored, soft water, eutrophic lake. The chemical type of water (predominant ionic composition) is sodium chloride.

Also of note:

- Cattails dominate more than 30% of the lake shoreline.

Plots and Trends: Before the construction of the Lake Josephine canal in the late 1960s, lake surface elevations fluctuated through a range of 4 to 5 feet. After the canal was constructed, the total range in fluctuation has been less than 2 feet with annual fluctuation mostly within a range of 1 foot. There are no trends in the plots of water chemistry. All plotted variables demonstrate a wide range of variation for sparse and sporadic data collected between 1973 and 1996. Also shown is a diagram of the relative ionic composition of the lake water.

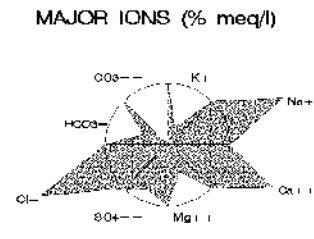
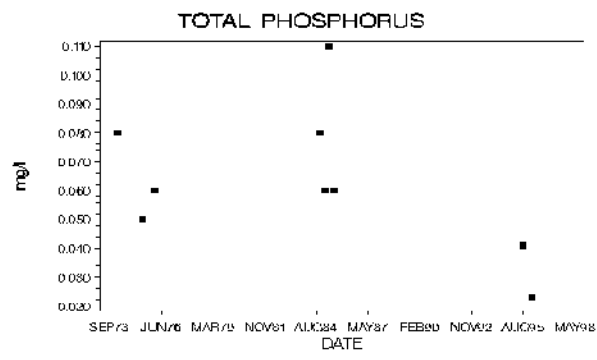
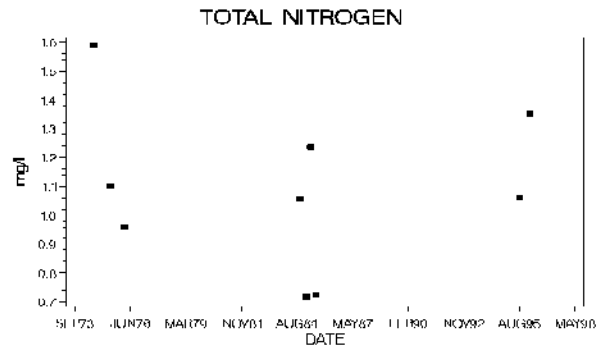
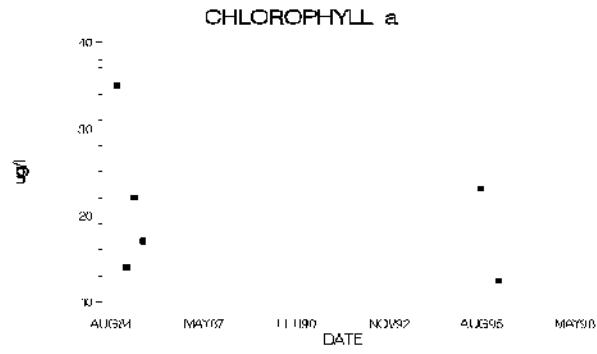
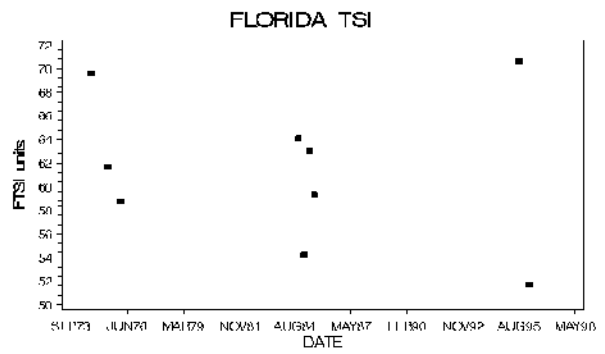
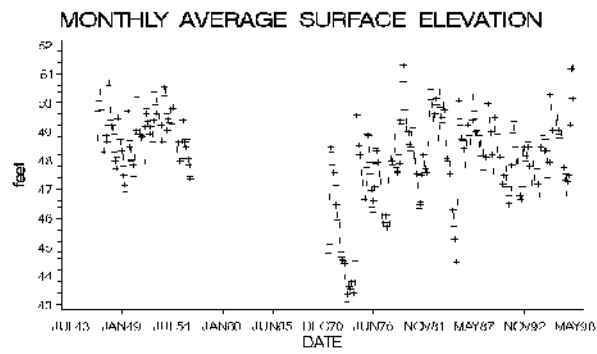

Lake Josephine Center, Highlands County

Lake Josephine East Highlands County

USGS Quadrangle: Sebring
 Section/Township/Range: 33-35S-29E
 Approx. Lake Center, Lat/Long: 272349/812541
 Surface Area: 473 acres
 Approx. Lake Elevation: 73 feet
 Average Depth: 3.9 feet
 Observed Maximum Depth: 7 feet
 (reference elevation 41 feet)
 Lake Type: inflow and outflow (type 3)
 Major Basin: Kissimmee Ridge
 Minor Basin: Josephine Creek
 Lake Region: Lake Wales Ridge Transition
 Public Access: yes

Major Land Use/Land Cover (1990)
 within 500 meters of the lakeshore:
 - medium density residential (20%)
 - pine flatwoods (13%)
 - tree crops, typically citrus (10%)

Total Number of Samples Collected: 12 Most Recent Sample Collected: January 1996

Parameter	Units (Detection Limit)	Average Value	District Percentile	Florida Percentile
Chlorophyll a	ug/l (1)	23.9	82	57
Total Phosphorus	mg/l as P (0.01)	0.041	84	36
Total Nitrogen	mg/l as N (0.06)	1.14	51	38
Transparency (Secchi depth)	meters	0.77	23	47
Florida Trophic State Index		63	87	61
Specific Conductance	S/cm at 25C (1)	117	18	30
pH	standard units (0.1)	6.2	8	10
Color	PtCo units (1)	60	82	50
Turbidity	NTU (1)	7.4	82	61
Total Alkalinity	mg/l as CaCO3 (1)	3	7	8
Hardness	mg/l as CaCO3 (0.02)	24	13	
Total Suspended Solids	mg/l (0.05)	11.5	92	
Ammonia	mg/l as N (0.03)	0.026	60	
Nitrate+Nitrite	mg/l as N (0.01)	0.084	79	
Total Kjeldahl Nitrogen	mg/l as N (0.06)	1.06	53	
Orthophosphorus	mg/l as P (0.01)	0.008	56	
Chloride	mg/l (0.05)	13	27	
Sulfate	mg/l (0.05)	8	31	
Sodium	mg/l (0.06)	5.2	14	
Potassium	mg/l (0.07)	1.3	22	
Calcium	mg/l (0.04)	4.9	14	
Magnesium	mg/l (0.006)	2.8	41	
Iron	ug/l (0.03)	126	86	

Based upon the average FTSI of 63, water quality is considered fair. Lake Josephine East can be characterized as a colored, soft water, eutrophic lake, with high concentrations of total phosphorus. The chemical type of water (predominant ionic composition) is sodium sulfate.

Plots and Trends: Before the construction of the Lake Josephine canal in the late 1960s, lake surface elevations fluctuated through a range of 4 to 5 feet. After the canal was constructed, the total range in fluctuation has been less than 2 feet with annual fluctuation mostly within a range of 1 foot. Though there appears to be a decline in total phosphorus over the period of record, there are insufficient data in the 1970s and 1980s to conclude there is a trend. Many of the total P concentrations for 1990s samples had similar concentrations to the earlier samples. All plotted variables demonstrate a wide range of variation for sparse and sporadic data collected between 1973 and 1996. Also shown is a diagram of the relative ionic composition of the lake water.

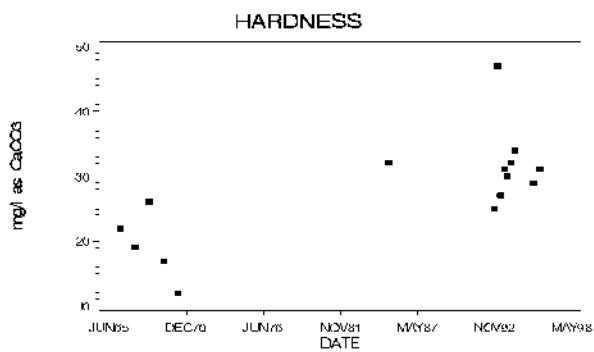
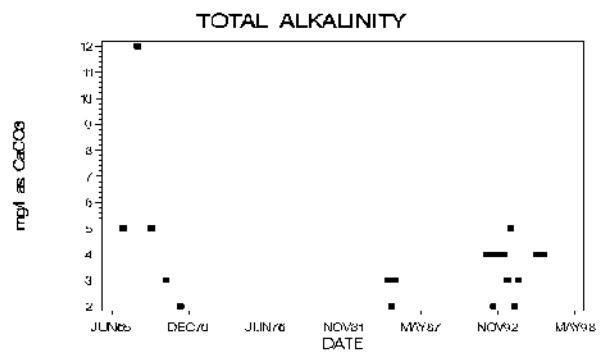
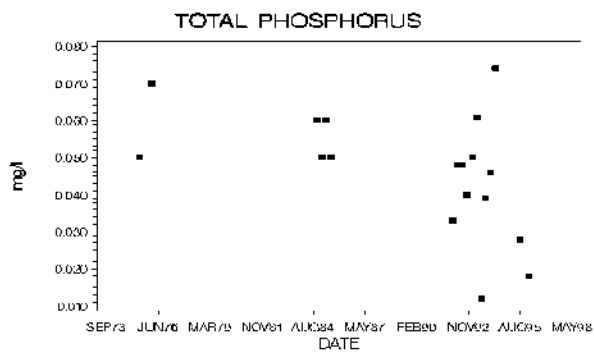
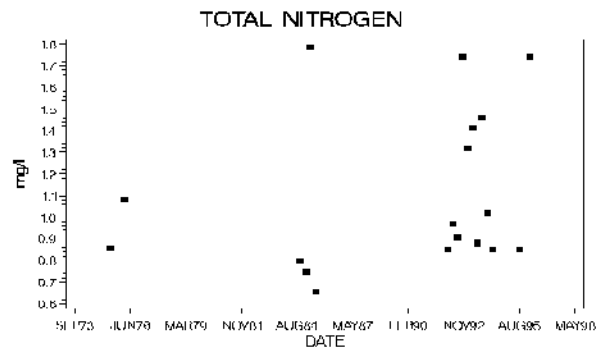
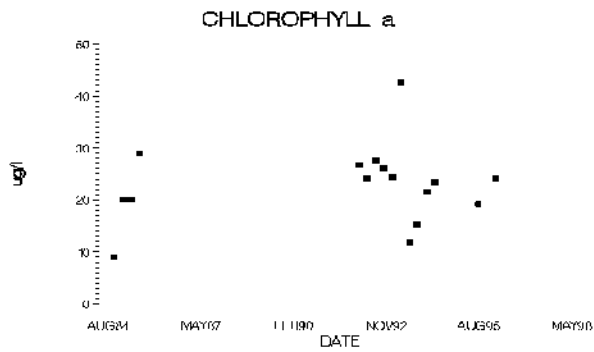
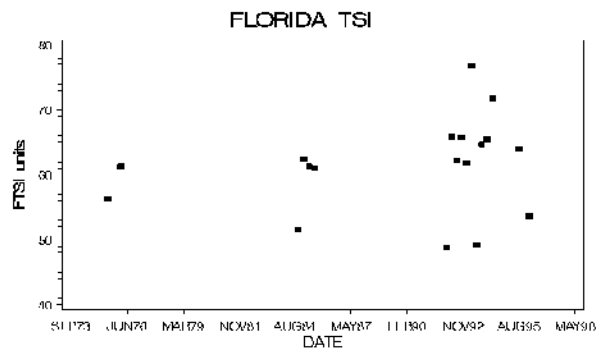
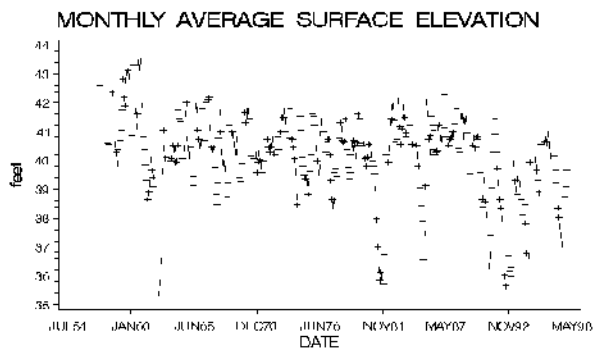

MAJOR IONS (% meq/l)

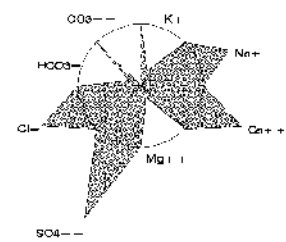

Lake Josephine East, Highlands County

Lake Josephine West

Highlands County

USGS Quadrangle: Sebring Major Land Use/Land Cover (1990)
 Section/Township/Range: 30-35S-29E within 500 meters of the lakeshore:
 Approx. Lake Center, Lat/Long: 272407/812709 - open land (24%)
 Surface Area: 385 acres - low density residential (15%)
 Approx. Lake Elevation: 73 feet - shrub and brushland range (14%)
 Average Depth: 3.9 feet
 Observed Maximum Depth: 6 feet
 (reference elevation 71 feet)
 Lake Type: inflow and outflow (type 3)
 Major Basin: Kissimmee Ridge
 Minor Basin: Josephine Creek
 Lake Region: Lake Wales Ridge Transition
 Public Access: yes

Total Number of Samples Collected: 2 Most Recent Sample Collected: January 1996

Parameter	Units (Detection Limit)	Average Value	District Percentile	Florida Percentile
Chlorophyll a	ug/l (1)	11.4	69	41
Total Phosphorus	mg/l as P (0.01)	0.065	90	48
Total Nitrogen	mg/l as N (0.06)	0.74	21	22
Transparency (Secchi depth)	meters	0.58	14	28
Florida Trophic State Index		49	71	34
Specific Conductance	S/cm at 25C (1)	78	6	15
pH	standard units (0.1)	6.4	12	15
Color	PtCo units (1)	168	95	93
Turbidity	NTU (1)	5.8	77	54
Total Alkalinity	mg/l as CaCO3 (1)	7	18	20
Hardness	mg/l as CaCO3 (0.02)	21	10	
Total Suspended Solids	mg/l (0.05)	6.8	85	
Ammonia	mg/l as N (0.03)	0.087	85	
Nitrate+Nitrite	mg/l as N (0.01)	0.025	57	
Total Kjeldahl Nitrogen	mg/l as N (0.06)	0.72	25	
Orthophosphorus	mg/l as P (0.01)	0.039	92	
Chloride	mg/l (0.05)	13	27	
Sulfate	mg/l (0.05)	5	20	
Sodium	mg/l (0.06)	6.7	30	
Potassium	mg/l (0.07)	1.5	25	
Calcium	mg/l (0.04)	5.5	16	
Magnesium	mg/l (0.006)	1.7	20	
Iron	ug/l (0.03)	290	95	

Based upon the average FTSI of 49, water quality is considered good. Lake Josephine West can be characterized as a highly colored, soft water, meso-eutrophic lake, with high concentrations of total phosphorus, low concentrations of total nitrogen. The chemical type of water (predominant ionic composition) is sodium chloride.

Also of note:

- Cattails dominate more than 30% of the lake shoreline.

Plots and Trends: Before the construction of the Lake Josephine canal in the late 1960s, lake surface elevations fluctuated through a range of 4 to 5 feet. After the canal was constructed, the total range in fluctuation has been less than 2 feet with annual fluctuation mostly within a range of 1 foot. There are insufficient data for Chlorophyll a to discuss changes; the relative amount of variation in chlorophyll concentrations is typical of most lakes. Also shown is a diagram of the relative ionic composition of the lake water.

MONTHLY AVERAGE SURFACE ELEVATION

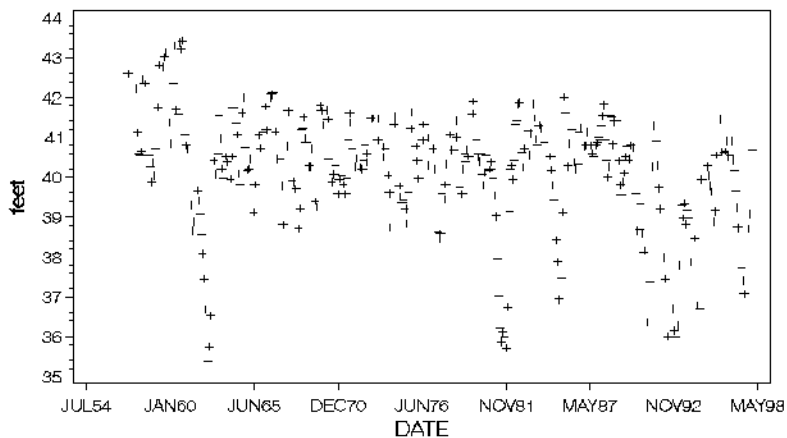

CHLOROPHYLL a

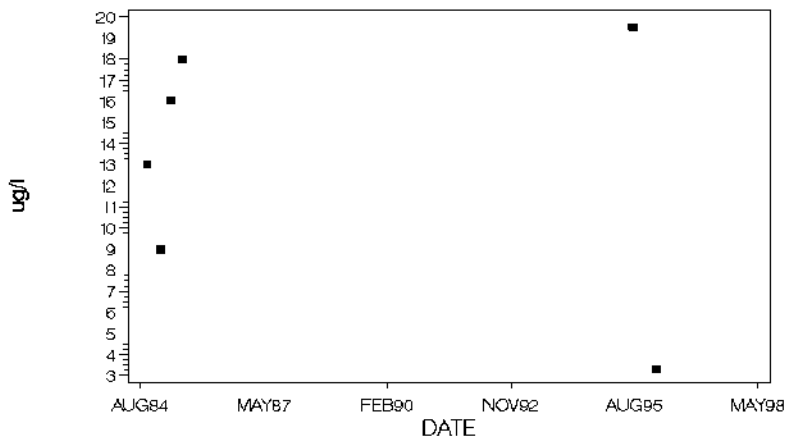

MAJOR IONS (% meq/l)

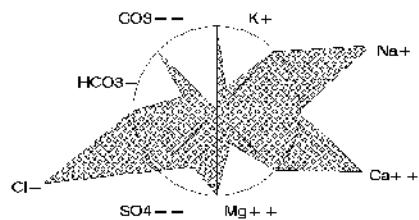

Lake Josephine West, Highlands County

Lake June in Winter Highlands County

USGS Quadrangle: Lake June in Winter
 Section/Township/Range: 34-36S-29E
 Approx. Lake Center, Lat/Long: 271757/812412
 Surface Area: 3504 acres
 Approx. Lake Elevation: 76 feet
 Average Depth: 17.1 feet
 Observed Maximum Depth: 35 feet
 (reference elevation not given)
 Lake Type: inflow and outflow (type 3)
 Major Basin: Kissimmee Ridge
 Minor Basin: Lake Francis Outlet
 Lake Region: Southern Lake Wales Ridge
 Public Access: yes

Major Land Use/Land Cover (1990)
 within 500 meters of the lakeshore:
 - tree crops, typically citrus (30%)
 - medium density residential (25%)
 - pine flatwoods (9%)

Total Number of Samples Collected: 4 Most Recent Sample Collected: April 1994

Parameter	Units (Detection Limit)	Average Value	District Percentile	Florida Percentile
Chlorophyll a	ug/l (1)	9.4	62	36
Total Phosphorus	mg/l as P (0.01)	0.010	33	5
Total Nitrogen	mg/l as N (0.06)	0.52	6	11
Transparency (Secchi depth)	meters	1.83	59	82
Florida Trophic State Index		38	50	13
Specific Conductance	S/cm at 25C (1)	170	45	46
pH	standard units (0.1)	7.2	43	40
Color	PtCo units (1)	5	9	5
Turbidity	NTU (1)	2.7	60	29
Total Alkalinity	mg/l as CaCO3 (1)	10	27	25
Hardness	mg/l as CaCO3 (0.02)	45	46	
Total Suspended Solids	mg/l (0.05)	2.1	54	
Ammonia	mg/l as N (0.03)	0.015	60	
Nitrate+Nitrite	mg/l as N (0.01)	0.053	71	
Total Kjeldahl Nitrogen	mg/l as N (0.06)	0.46	7	
Orthophosphorus	mg/l as P (0.01)	0.005	56	
Chloride	mg/l (0.05)	18	46	
Sulfate	mg/l (0.05)	8	31	
Sodium	mg/l (0.06)	8.5	48	
Potassium	mg/l (0.07)	5.2	67	
Calcium	mg/l (0.04)	9.0	33	
Magnesium	mg/l (0.006)	5.5	73	
Iron	ug/l (0.03)	32	42	

Based upon the average FTSI of 38, water quality is considered good. Lake June in Winter can be characterized as a clear (color<=10 color units), soft water, meso-eutrophic lake, with very low concentrations of total nitrogen. The chemical type of water (predominant ionic composition) is calcium sulfate.

Plots and Trends: Lake June in Winter surface elevations have been relatively stable over the long (>50 years) period of record. Most of the water chemistry plots demonstrate that the recent samples collected from the lake are within the historic ranges for the respective variables. A trend is suggested by the data for specific conductivity, however, due to the gaps in the available data, it is difficult to conclude there is a long term trend or change. Also shown is a diagram of the relative ionic composition of the lake water.

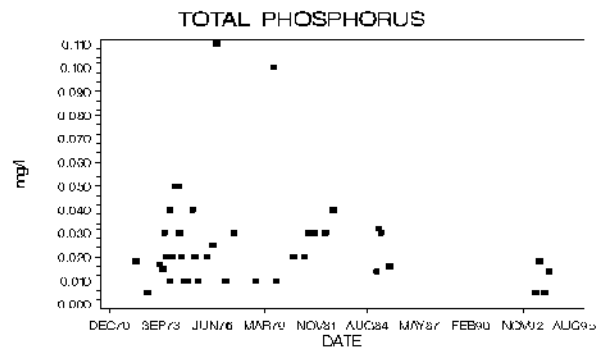
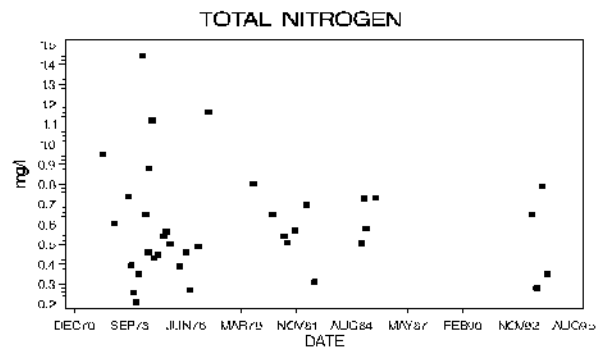
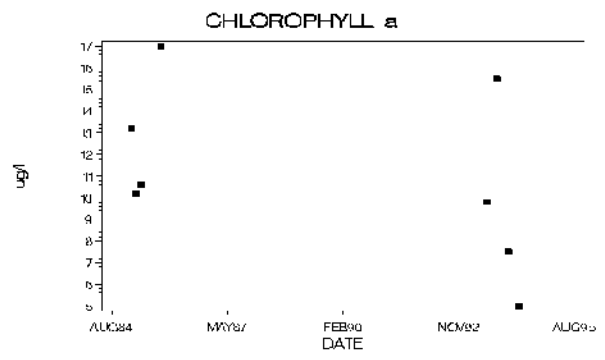
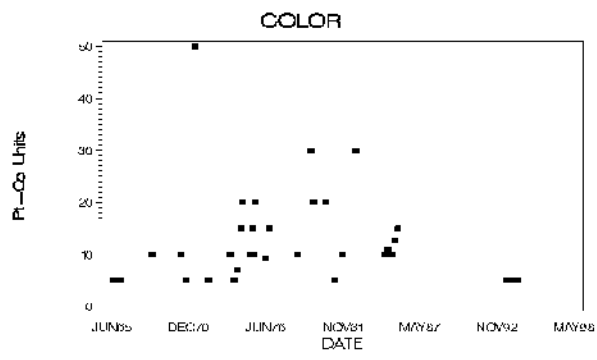
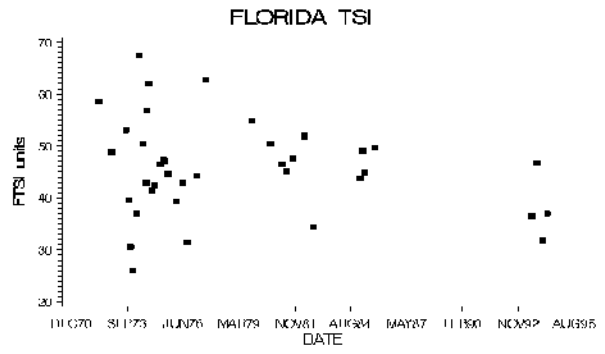
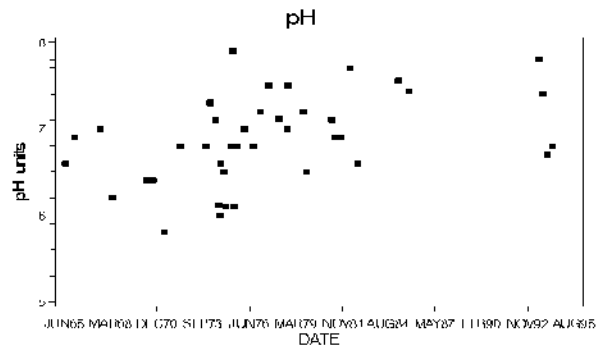
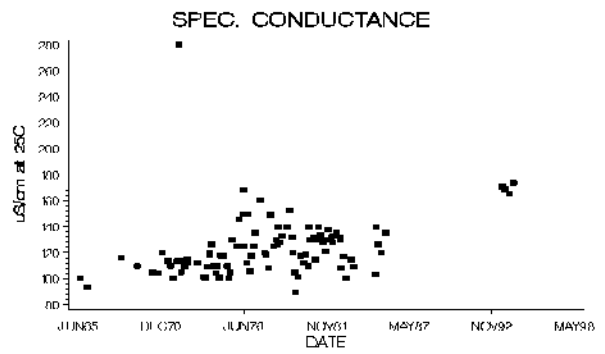
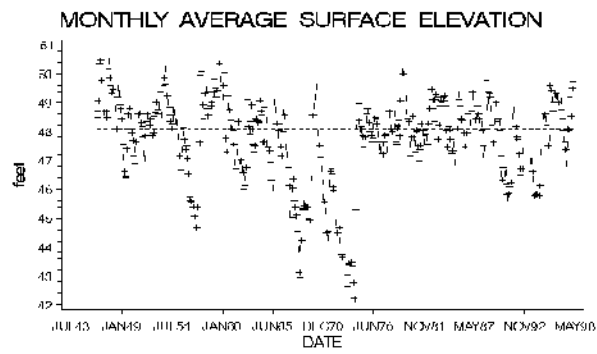

Lake June in Winter, Highlands County

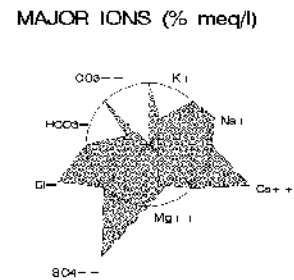
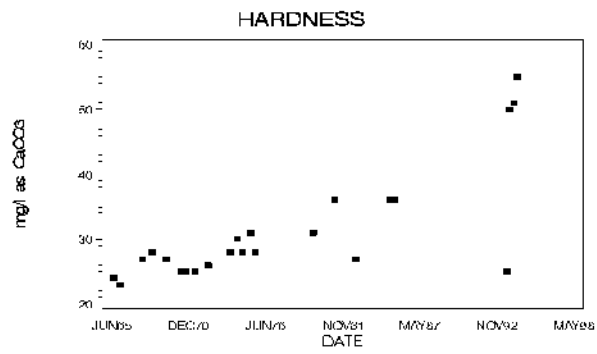
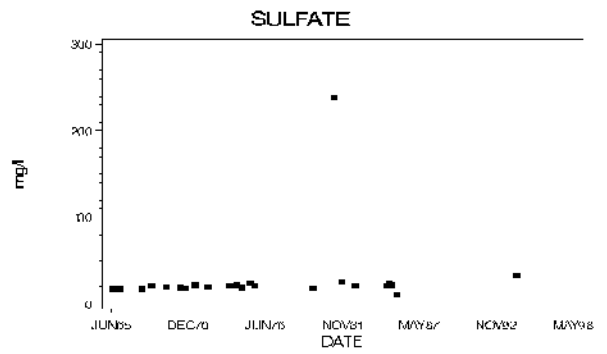
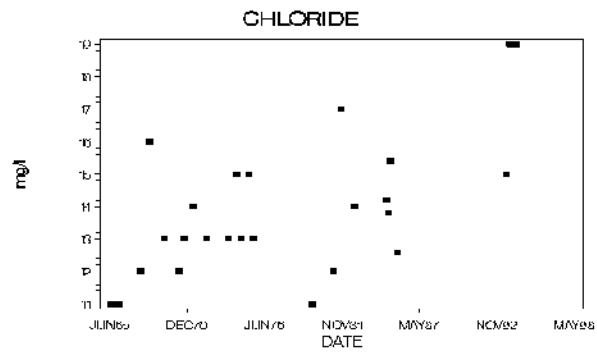
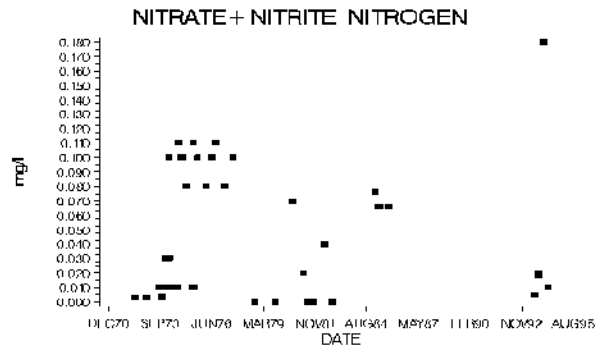
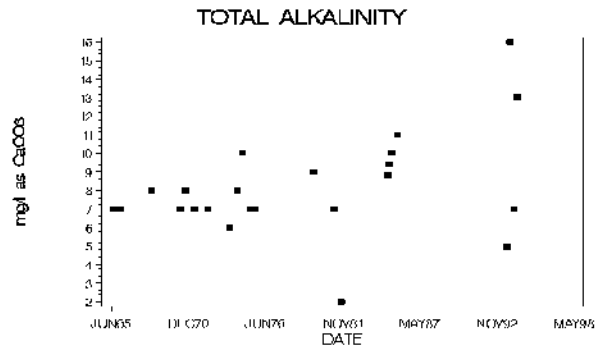
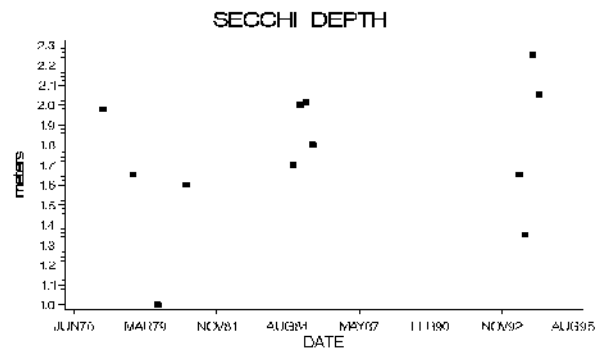
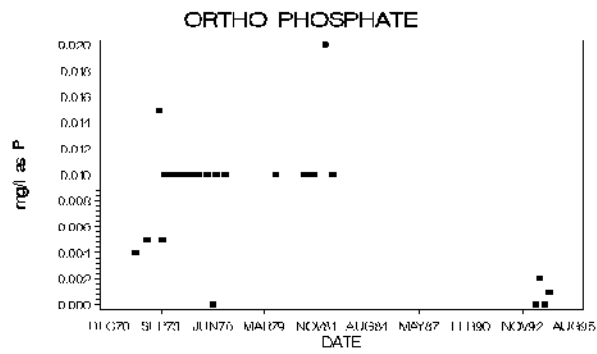

Lake June in Winter, Highlands County

Lake Lachard Highlands County

USGS Quadrangle:	Lake Placid	Major Land Use/Land Cover (1990)
Section/Township/Range:	36-36S-29E	within 500 meters of the lakeshore:
Approx. Lake Center, Lat/Long:	271814/812209	- tree crops, typically citrus (44%)
Surface Area:	15 acres	- low density residential (14%)
Approx. Lake Elevation:	79 feet	- medium density residential (14%)
Average Depth: 21.9 feet		
Observed Maximum Depth: 46 feet (reference elevation 76 feet)		
Lake Type: isolated (type 4)		
Major Basin: Kissimmee Ridge		
Minor Basin: Lake Francis Outlet		
Lake Region: Southern Lake Wales Ridge		

Total Number of Samples Collected: 2 Most Recent Sample Collected: January 1996

Parameter	Units (Detection Limit)	Average Value	District Percentile	Florida Percentile
Chlorophyll a	ug/l (1)	10.4	66	39
Total Phosphorus	mg/l as P (0.01)	0.010	33	5
Total Nitrogen	mg/l as N (0.06)	0.99	40	33
Transparency (Secchi depth)	meters	2.00	64	85
Florida Trophic State Index		48	70	31
Specific Conductance	S/cm at 25C (1)	212	64	54
pH	standard units (0.1)	8.2	85	75
Color	PtCo units (1)	5	9	5
Turbidity	NTU (1)	3.5	67	37
Total Alkalinity	mg/l as CaCO3 (1)	41	72	57
Hardness	mg/l as CaCO3 (0.02)	65	68	
Total Suspended Solids	mg/l (0.05)	2.1	54	
Ammonia	mg/l as N (0.03)	0.090	86	
Nitrate+Nitrite	mg/l as N (0.01)	0.433	90	
Total Kjeldahl Nitrogen	mg/l as N (0.06)	0.56	12	
Orthophosphorus	mg/l as P (0.01)	0.005	56	
Chloride	mg/l (0.05)	20	56	
Sulfate	mg/l (0.05)	27	73	
Sodium	mg/l (0.06)	11.0	64	
Potassium	mg/l (0.07)	5.5	70	
Calcium	mg/l (0.04)	20.5	77	
Magnesium	mg/l (0.006)	3.3	49	
Iron	ug/l (0.03)	7	<5	

Based upon the average FTSI of 48, water quality is considered good. Lake Lachard can be characterized as a clear (color<=10 color units), medium hard water, meso-eutrophic lake. The chemical type of water (predominant ionic composition) is calcium chloride.

Also of note:

- The measured pH was high.

Plots and Trends: No or insufficient data available for plotting or trend detection. Shown is a diagram of the relative ionic composition of the lake water.

MAJOR IONS (% meq/l)

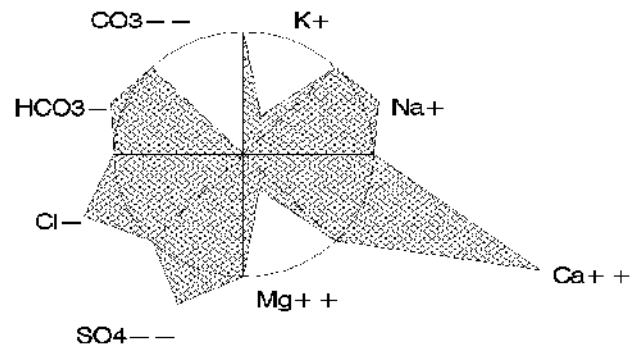

Lake Lelia

Highlands County

USGS Quadrangle: Avon Park Major Land Use/Land Cover (1990)
 Section/Township/Range: 34-33S-28E within 500 meters of the lakeshore:
 Approx. Lake Center, Lat/Long: 273424/813016 - medium density residential (17%)
 Surface Area: 165 acres - tree crops, typically citrus (17%)
 Approx. Lake Elevation: 115 feet - commercial and services (11%)
 Lake Type: inflow and outflow (type 3)
 Major Basin: Kissimmee Ridge
 Minor Basin: Carter Creek
 Lake Region: Lake Wales Ridge Transition
 Public Access: yes

Total Number of Samples Collected: 2 Most Recent Sample Collected: January 1995

Parameter	Units (Detection Limit)	Average Value	District Percentile	Florida Percentile
Chlorophyll a	ug/l (1)	7.7	56	32
Total Phosphorus	mg/l as P (0.01)	0.012	41	6
Total Nitrogen	mg/l as N (0.06)	1.26	58	43
Transparency (Secchi depth)	meters	1.65	54	79
Florida Trophic State Index		40	53	16
Specific Conductance	S/cm at 25C (1)	182	51	49
pH	standard units (0.1)	7.4	57	50
Color	PtCo units (1)	8	24	8
Turbidity	NTU (1)	4.2	71	43
Total Alkalinity	mg/l as CaCO3 (1)	22	45	41
Hardness	mg/l as CaCO3 (0.02)	42	39	
Total Suspended Solids	mg/l (0.05)	3.8	71	
Ammonia	mg/l as N (0.03)	0.015	60	
Nitrate+Nitrite	mg/l as N (0.01)	0.275	88	
Total Kjeldahl Nitrogen	mg/l as N (0.06)	0.99	47	
Orthophosphorus	mg/l as P (0.01)	0.014	76	
Chloride	mg/l (0.05)	17	41	
Sulfate	mg/l (0.05)	29	75	
Sodium	mg/l (0.06)	8.5	48	
Potassium	mg/l (0.07)	6.2	74	
Calcium	mg/l (0.04)	7.9	28	
Magnesium	mg/l (0.006)	5.5	73	
Iron	ug/l (0.03)	14	8	

Based upon the average FTSI of 40, water quality is considered good. Lake Lelia can be characterized as a clear (color<=10 color units), soft water, meso-eutrophic lake. The chemical type of water (predominant ionic composition) is calcium sulfate (2 samples) or sodium sulfate (1 sample).

Plots and Trends: Lake surface elevations have trended upward over the relatively short period of record. Also shown is a diagram of the relative ionic composition of the lake water.

MONTHLY AVERAGE SURFACE ELEVATION

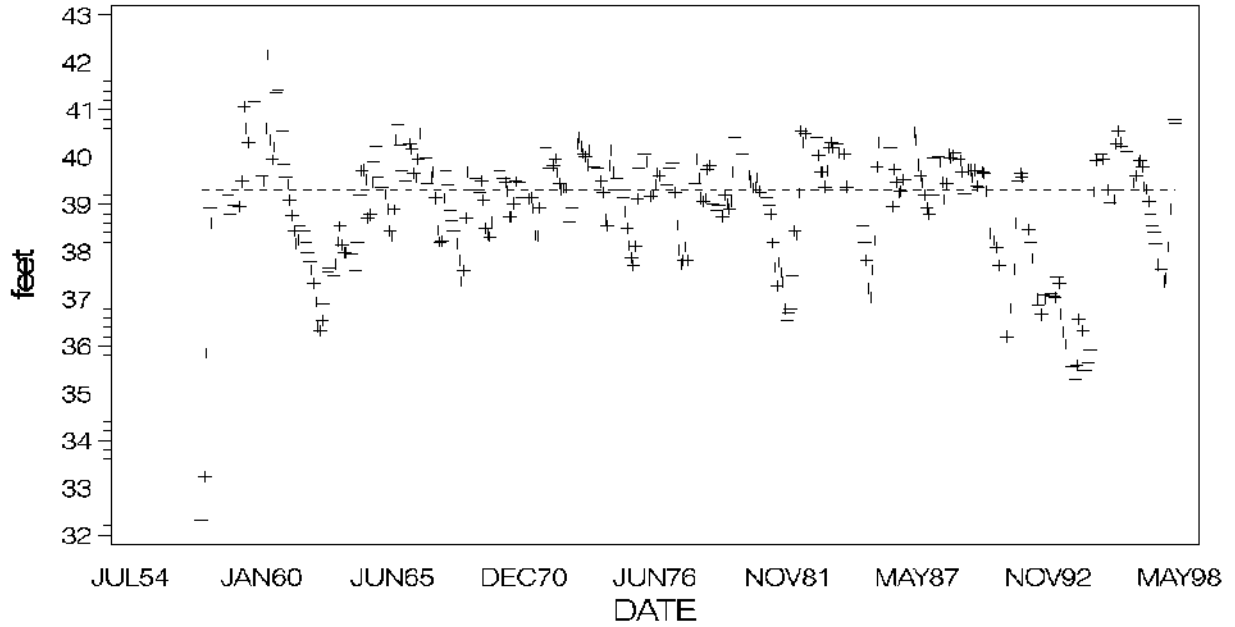

MAJOR IONS (% meq/l)

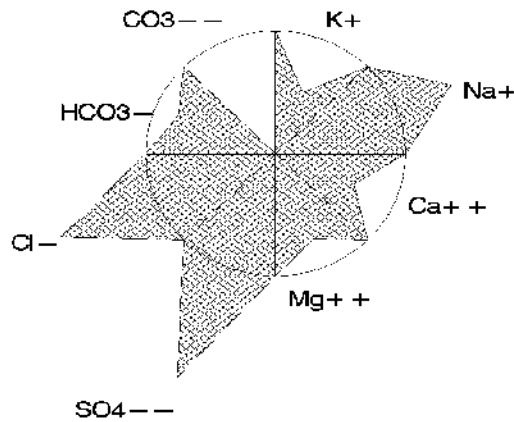

Lake Letta

Highlands County

USGS Quadrangle: Lake Arbuckle SW Major Land Use/Land Cover (1990)
 Section/Township/Range: 31-33S-29E within 500 meters of the lakeshore:
 Approx. Lake Center, Lat/Long: 273340/812742 - tree crops, typically citrus (45%)
 Surface Area: 478 acres - medium density residential (19%)
 Approx. Lake Elevation: 100 feet - hardwood - conifer mixed (11%)
 Average Depth: 5.2 feet
 Observed Maximum Depth: 9 feet
 (reference elevation 91 feet)
 Lake Type: inflow and outflow (type 3)
 Major Basin: Kissimmee Ridge
 Minor Basin: Carter Creek
 Lake Region: Lake Wales Ridge Transition
 Public Access: yes

Total Number of Samples Collected: 2 Most Recent Sample Collected: January 1995

Parameter	Units (Detection Limit)	Average Value	District Percentile	Florida Percentile
Chlorophyll a	ug/l (1)	2.1	13	9
Total Phosphorus	mg/l as P (0.01)	0.025	72	15
Total Nitrogen	mg/l as N (0.06)	1.17	53	39
Transparency (Secchi depth)	meters	1.20	40	70
Florida Trophic State Index		41	55	17
Specific Conductance	S/cm at 25C (1)	155	40	43
pH	standard units (0.1)	6.9	29	28
Color	PtCo units (1)	5	9	5
Turbidity	NTU (1)	2.3	55	24
Total Alkalinity	mg/l as CaCO3 (1)	3	7	8
Hardness	mg/l as CaCO3 (0.02)	35	28	
Total Suspended Solids	mg/l (0.05)	3.5	67	
Ammonia	mg/l as N (0.03)	0.015	60	
Nitrate+Nitrite	mg/l as N (0.01)	0.005	33	
Total Kjeldahl Nitrogen	mg/l as N (0.06)	1.17	60	
Orthophosphorus	mg/l as P (0.01)	0.014	76	
Chloride	mg/l (0.05)	20	56	
Sulfate	mg/l (0.05)	30	77	
Sodium	mg/l (0.06)	8.5	48	
Potassium	mg/l (0.07)	4.9	65	
Calcium	mg/l (0.04)	3.9	8	
Magnesium	mg/l (0.006)	6.2	77	
Iron	ug/l (0.03)	43	55	

Based upon the average FTSI of 41, water quality is considered good. Lake Letta can be characterized as a clear (color<=10 color units), soft water, oligotrophic lake. The chemical type of water (predominant ionic composition) is sodium sulfate.

Plots and Trends: Lake elevations remained high during the first half of the period of record (1950 to 1969). In the early 1970s, lake levels rapidly declined and remained generally low until 1998. More recent levels (through February 1999, not shown) have remained above 97 feet. There are inadequate data to determine long-term changes in water quality. Also shown is a diagram of the relative ionic composition of the lake water.

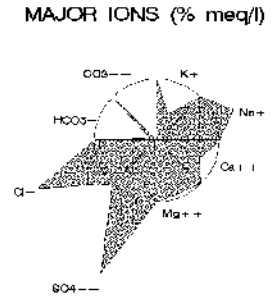
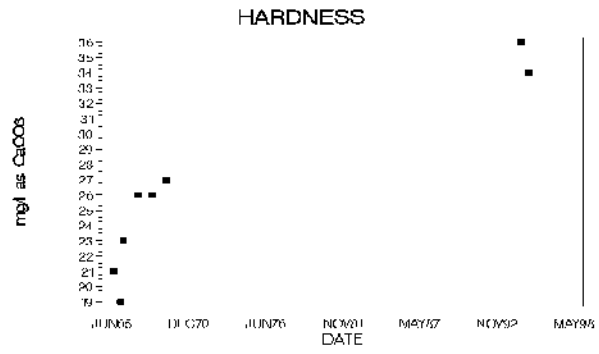
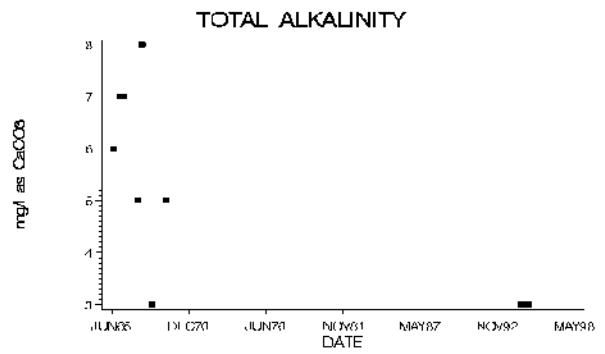
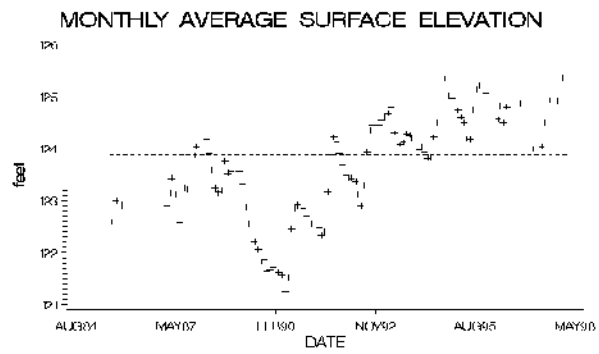

Lake Letta, Highlands County

Lake Lillian

Highlands County

USGS Quadrangle: Frostproof Major Land Use/Land Cover (1990)
 Section/Township/Range: 9-33S-28E within 500 meters of the lakeshore:
 Approx. Lake Center, Lat/Long: 273751/813111 - medium density residential (38%)
 Surface Area: 31 acres - tree crops, typically citrus (22%)
 Approx. Lake Elevation: 106 feet - other open lands - rural (9%)
 Average Depth: 21 feet
 Observed Maximum Depth: 41 feet
 (reference elevation not given)
 Lake Type: isolated (type 4)
 Major Basin: Kissimmee Ridge
 Minor Basin: Grassy Creek
 Lake Region: Southern Lake Wales Ridge

Total Number of Samples Collected: 2 Most Recent Sample Collected: January 1995

Parameter	Units (Detection Limit)	Average Value	District Percentile	Florida Percentile
Chlorophyll a	ug/l (1)	1.6	7	6
Total Phosphorus	mg/l as P (0.01)	0.010	33	5
Total Nitrogen	mg/l as N (0.06)	0.69	16	20
Transparency (Secchi depth)	meters	4.20	94	>95
Florida Trophic State Index		23	10	<5
Specific Conductance	S/cm at 25C (1)	149	38	42
pH	standard units (0.1)	6.6	18	20
Color	PtCo units (1)	5	9	5
Turbidity	NTU (1)	0.8	28	<5
Total Alkalinity	mg/l as CaCO3 (1)	24	48	43
Hardness	mg/l as CaCO3 (0.02)	45	46	
Total Suspended Solids	mg/l (0.05)	0.9	24	
Ammonia	mg/l as N (0.03)	0.015	60	
Nitrate+Nitrite	mg/l as N (0.01)	0.145	84	
Total Kjeldahl Nitrogen	mg/l as N (0.06)	0.54	10	
Orthophosphorus	mg/l as P (0.01)	0.014	76	
Chloride	mg/l (0.05)	11	19	
Sulfate	mg/l (0.05)	29	75	
Sodium	mg/l (0.06)	5.3	15	
Potassium	mg/l (0.07)	7.8	86	
Calcium	mg/l (0.04)	10.5	41	
Magnesium	mg/l (0.006)	4.5	63	
Iron	ug/l (0.03)	10	<5	

Based upon the average FTSI of 23, water quality is considered good. Lake Lillian can be characterized as a clear (color<=10 color units), soft water, oligotrophic lake, with low concentrations of total nitrogen. The chemical type of water (predominant ionic composition) is calcium sulfate.

Plots and Trends: No or insufficient data available for plotting or trend detection. Shown is a diagram of the relative ionic composition of the lake water.

MAJOR IONS (% meq/l)

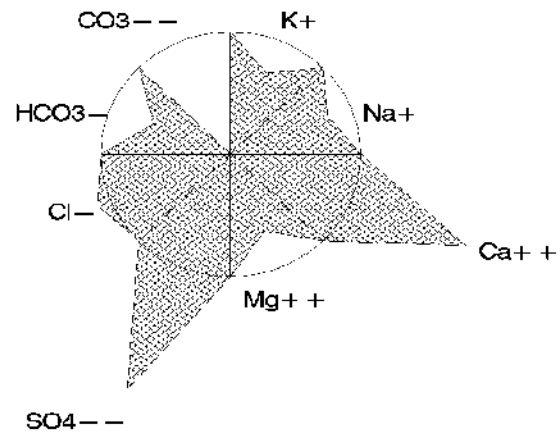

Little Red Water Lake (South) Highlands County

USGS Quadrangle: Lake June-in-Winter
 Section/Township/Range: 14-36S-29E
 Approx. Lake Center, Lat/Long: 272055/812328
 Surface Area: 21 acres
 Approx. Lake Elevation: 71 feet
 Lake Type: outflow (type 2)
 Major Basin: Kissimmee Ridge
 Minor Basin: Lake Francis Outlet
 Lake Region: Lake Wales Ridge Transition
 Public Access: yes

Major Land Use/Land Cover (1990)
 within 500 meters of the lakeshore:
 - tree crops, typically citrus (43%)
 - medium density residential (20%)
 - cropland and pastureland (12%)

Total Number of Samples Collected: 2 Most Recent Sample Collected: February 1995

Parameter	Units (Detection Limit)	Average Value	District Percentile	Florida Percentile
Chlorophyll a	ug/l (1)	10.7	66	39
Total Phosphorus	mg/l as P (0.01)	0.005	31	<5
Total Nitrogen	mg/l as N (0.06)	1.76	77	73
Transparency (Secchi depth)	meters	1.90	61	83
Florida Trophic State Index		35	41	9
Specific Conductance	S/cm at 25C (1)	207	62	53
pH	standard units (0.1)	6.9	29	28
Color	PtCo units (1)	8	24	8
Turbidity	NTU (1)	3.1	64	33
Total Alkalinity	mg/l as CaCO3 (1)	15	36	33
Hardness	mg/l as CaCO3 (0.02)	63	65	
Total Suspended Solids	mg/l (0.05)	2.4	57	
Ammonia	mg/l as N (0.03)	0.015	60	
Nitrate+Nitrite	mg/l as N (0.01)	0.020	51	
Total Kjeldahl Nitrogen	mg/l as N (0.06)	1.75	84	
Orthophosphorus	mg/l as P (0.01)	0.005	56	
Chloride	mg/l (0.05)	25	76	
Sulfate	mg/l (0.05)	40	88	
Sodium	mg/l (0.06)	9.3	55	
Potassium	mg/l (0.07)	8.4	87	
Calcium	mg/l (0.04)	10.4	39	
Magnesium	mg/l (0.006)	8.8	85	
Iron	ug/l (0.03)	22	26	

Based upon the average FTSI of 35, water quality is considered good. Little Red Water Lake (South) can be characterized as a clear (color<=10 color units), medium hard water, meso-eutrophic lake, with low concentrations of total phosphorus. The chemical type of water (predominant ionic composition) is calcium sulfate.

Plots and Trends: No or insufficient data available for plotting or trend detection. Shown is a diagram of the relative ionic composition of the lake water.

MAJOR IONS (% meq/l)

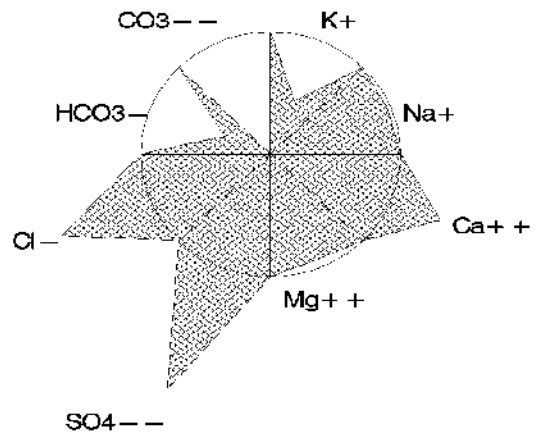

Little Red Water Lake (South), Highlands County

Little Lake Jackson

Highlands County

USGS Quadrangle: Sebring
 Section/Township/Range: 6-35S-29E
 Approx. Lake Center, Lat/Long: 272808/812750
 Surface Area: 125 acres
 Approx. Lake Elevation: 103 feet
 Average Depth: 11.8 feet
 Observed Maximum Depth: 21 feet
 (reference elevation 92.94 feet)
 Lake Type: inflow and outflow (type 3)
 Major Basin: Kissimmee Ridge
 Minor Basin: Josephine Creek
 Lake Region: Lake Wales Ridge Transition
 Public Access: yes

Major Land Use/Land Cover (1990)
 within 500 meters of the lakeshore:
 - recreational (26%)
 - medium density residential (23%)
 - freshwater marshes (15%)

Total Number of Samples Collected: 6 Most Recent Sample Collected: February 1995

Parameter	Units (Detection Limit)	Average Value	District Percentile	Florida Percentile
Chlorophyll a	ug/l (1)	22.5	81	55
Total Phosphorus	mg/l as P (0.01)	0.050	87	40
Total Nitrogen	mg/l as N (0.06)	1.07	46	36
Transparency (Secchi depth)	meters	1.24	41	71
Florida Trophic State Index		55	79	45
Specific Conductance	S/cm at 25C (1)	147	36	41
pH	standard units (0.1)	7.6	64	57
Color	PtCo units (1)	28	65	22
Turbidity	NTU (1)	5.9	77	55
Total Alkalinity	mg/l as CaCO3 (1)	16	37	34
Hardness	mg/l as CaCO3 (0.02)	42	39	
Total Suspended Solids	mg/l (0.05)	4.2	74	
Ammonia	mg/l as N (0.03)	0.015	60	
Nitrate+Nitrite	mg/l as N (0.01)	0.034	61	
Total Kjeldahl Nitrogen	mg/l as N (0.06)	1.04	51	
Orthophosphorus	mg/l as P (0.01)	0.010	59	
Chloride	mg/l (0.05)	16	37	
Sulfate	mg/l (0.05)	11	39	
Sodium	mg/l (0.06)	8.5	48	
Potassium	mg/l (0.07)	4.6	62	
Calcium	mg/l (0.04)	11.3	44	
Magnesium	mg/l (0.006)	3.2	48	
Iron	ug/l (0.03)	21	24	

Based upon the average FTSI of 55, water quality is considered good. Little Lake Jackson can be characterized as a moderately colored, soft water, eutrophic lake, with high concentrations of total phosphorus. The chemical type of water (predominant ionic composition) is calcium chloride (2 samples) or calcium sulfate (1 sample).

Plots and Trends: As shown in plots of lake elevation for other lakes in the Lake Wales Ridge region, Little Lake Jackson surface elevations have generally increased during the 1990s, recovering from the drought years in the mid- to late 1980s in the Lake Wales Ridge region. Chlorophyll a concentrations ranged from 13 to nearly 60 g/l through the 1990s. Also shown is a diagram of the relative ionic composition of the lake water.

MONTHLY AVERAGE SURFACE ELEVATION

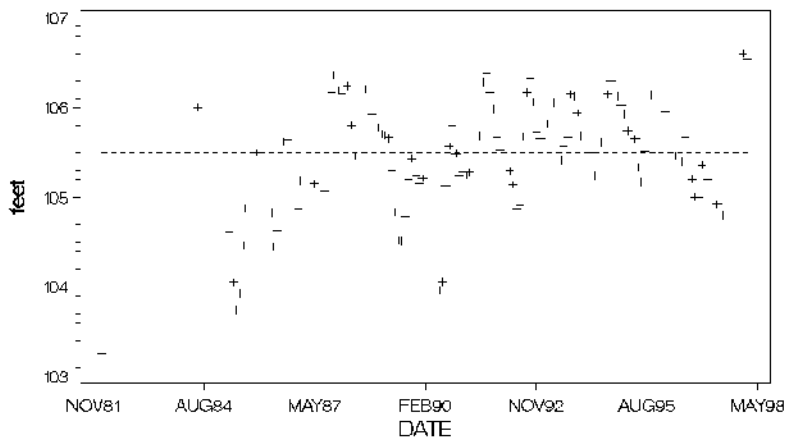

CHLOROPHYLL a

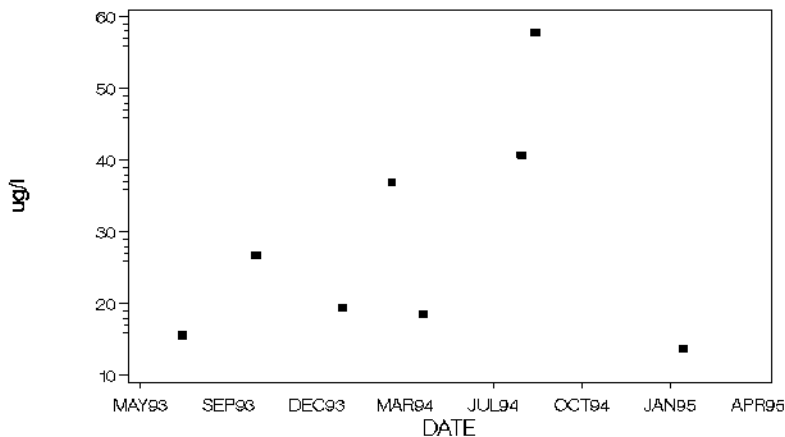

MAJOR IONS (% meq/l)

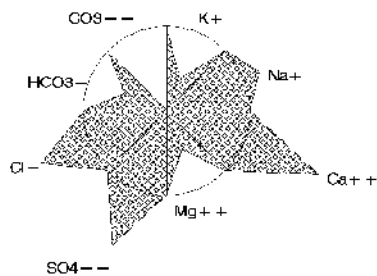

Little Jackson Lake, Highlands County

Little Red Water Lake (North) Highlands County

USGS Quadrangle: Lake Arbuckle SW Major Land Use/Land Cover (1990)
 Section/Township/Range: 12-34S-28E within 500 meters of the lakeshore:
 Approx. Lake Center, Lat/Long: 273225/812820 - tree crops, typically citrus (39%)
 Surface Area: 329 acres - medium density residential (14%)
 Approx. Lake Elevation: 103 feet - open land (10%)
 Average Depth: 9.8 feet
 (reference elevation 92.94 feet)
 Lake Type: inflow and outflow (type 3)
 Major Basin: Kissimmee Ridge
 Minor Basin: Little Red Water Lk 01
 Lake Region: Lake Wales Ridge Transition

Total Number of Samples Collected: 2 Most Recent Sample Collected: January 1995

Parameter	Units (Detection Limit)	Average Value	District Percentile	Florida Percentile
Chlorophyll a	ug/l (1)	5.9	49	25
Total Phosphorus	mg/l as P (0.01)	0.009	31	<5
Total Nitrogen	mg/l as N (0.06)	0.44	<5	7
Transparency (Secchi depth)	meters	1.10	38	67
Florida Trophic State Index		41	55	17
Specific Conductance	S/cm at 25C (1)	90	11	19
pH	standard units (0.1)	6.8	25	25
Color	PtCo units (1)	35	70	27
Turbidity	NTU (1)	2.7	60	29
Total Alkalinity	mg/l as CaCO3 (1)	4	10	10
Hardness	mg/l as CaCO3 (0.02)	13	<5	
Total Suspended Solids	mg/l (0.05)	2.8	62	
Ammonia	mg/l as N (0.03)	0.015	60	
Nitrate+Nitrite	mg/l as N (0.01)	0.005	33	
Total Kjeldahl Nitrogen	mg/l as N (0.06)	0.44	6	
Orthophosphorus	mg/l as P (0.01)	0.014	76	
Chloride	mg/l (0.05)	15	34	
Sulfate	mg/l (0.05)	10	37	
Sodium	mg/l (0.06)	8.4	47	
Potassium	mg/l (0.07)	1.7	28	
Calcium	mg/l (0.04)	2.7	5	
Magnesium	mg/l (0.006)	1.6	18	
Iron	ug/l (0.03)	84	77	

Based upon the average FTSI of 41, water quality is considered good. Little Red Water Lake (North) can be characterized as a moderately colored, soft water, meso-eutrophic lake, with low concentrations of total phosphorus, very low concentrations of total nitrogen. The chemical type of water (predominant ionic composition) is sodium chloride.

Plots and Trends: Lake levels in the 1990s appear to be somewhat greater than those recorded during the 1980s. This is reflective of the increasing trend in rainfall from the period of relative drought in the mid- and late 1980s in the Lake Wales Ridge region. Also shown is a diagram of the relative ionic composition of the lake water.

MONTHLY AVERAGE SURFACE ELEVATION

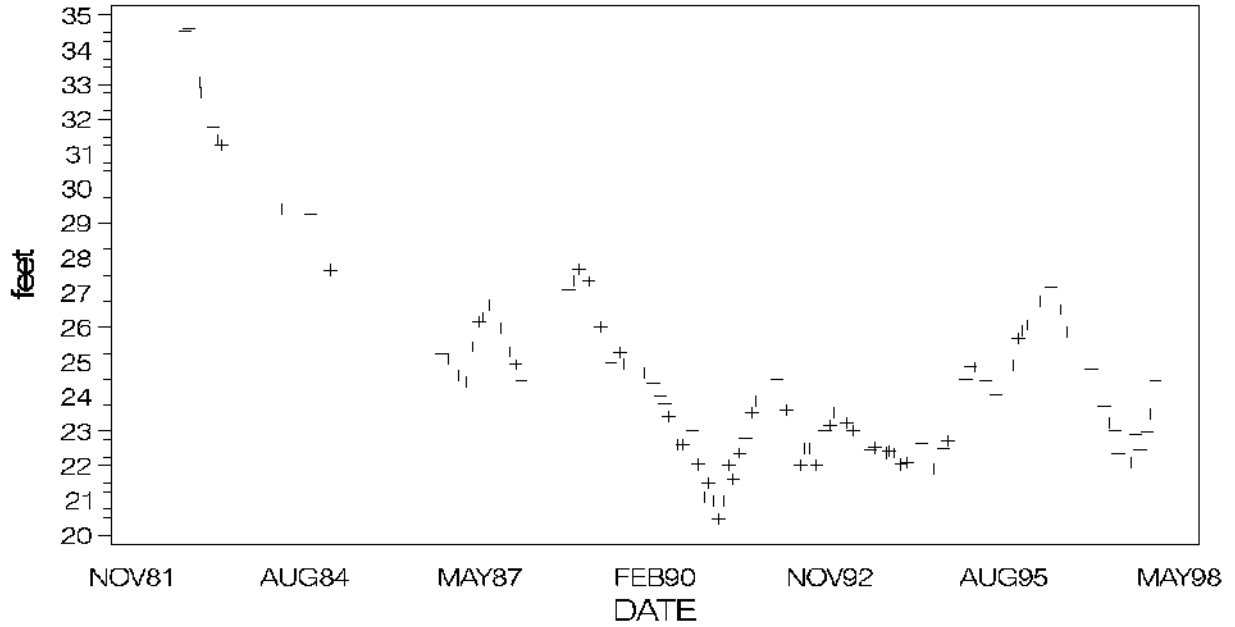

MAJOR IONS (% meq/l)

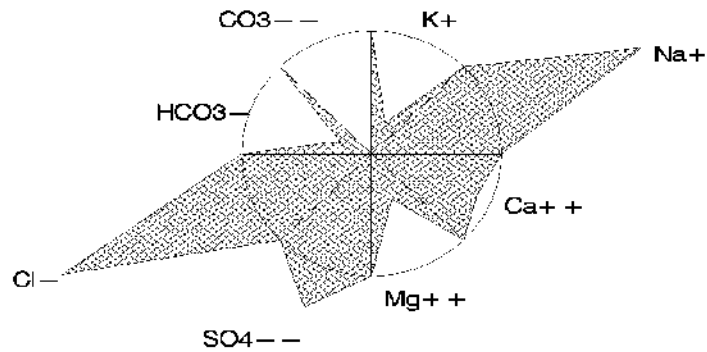

Little Red Water Lake (North), Highlands County

Little Bonnet Lake

Highlands County

USGS Quadrangle: Lake Arbuckle SW Major Land Use/Land Cover (1990)
 Section/Township/Range: 36-33S-28E within 500 meters of the lakeshore:
 Approx. Lake Center, Lat/Long: 273338/812833 - tree crops, typically citrus (35%)
 Surface Area: 84 acres - recreational (18%)
 Approx. Lake Elevation: 100 feet - shrub and brushland range (12%)
 Lake Type: inflow and outflow (type 3)
 Major Basin: Kissimmee Ridge
 Minor Basin: Carter Creek
 Lake Region: Lake Wales Ridge Transition
 Public Access: yes

Total Number of Samples Collected: 2 Most Recent Sample Collected: January 1995

Parameter	Units (Detection Limit)	Average Value	District Percentile	Florida Percentile
Chlorophyll a	ug/l (1)	20.0	79	52
Total Phosphorus	mg/l as P (0.01)	0.015	53	8
Total Nitrogen	mg/l as N (0.06)	3.24	95	92
Transparency (Secchi depth)	meters	0.50	9	20
Florida Trophic State Index		60	84	55
Specific Conductance	S/cm at 25C (1)	260	80	62
pH	standard units (0.1)	7.9	78	67
Color	PtCo units (1)	10	34	10
Turbidity	NTU (1)	12.8	92	74
Total Alkalinity	mg/l as CaCO3 (1)	25	50	44
Hardness	mg/l as CaCO3 (0.02)	84	83	
Total Suspended Solids	mg/l (0.05)	10.6	91	
Ammonia	mg/l as N (0.03)	0.175	95	
Nitrate+Nitrite	mg/l as N (0.01)	0.180	86	
Total Kjeldahl Nitrogen	mg/l as N (0.06)	3.06	>95	
Orthophosphorus	mg/l as P (0.01)	0.016	82	
Chloride	mg/l (0.05)	23	69	
Sulfate	mg/l (0.05)	53	94	
Sodium	mg/l (0.06)	9.2	54	
Potassium	mg/l (0.07)	8.5	87	
Calcium	mg/l (0.04)	16.5	64	
Magnesium	mg/l (0.006)	10.4	88	
Iron	ug/l (0.03)	31	40	

Based upon the average FTSI of 60, water quality is considered fair. Little Bonnet Lake can be characterized as a clear (color<=10 color units), medium hard water, eutrophic lake, with high concentrations of total nitrogen. The chemical type of water (predominant ionic composition) is calcium sulfate.

Plots and Trends: No or insufficient data available for plotting or trend detection. Shown is a diagram of the relative ionic composition of the lake water.

MAJOR IONS (% meq/l)

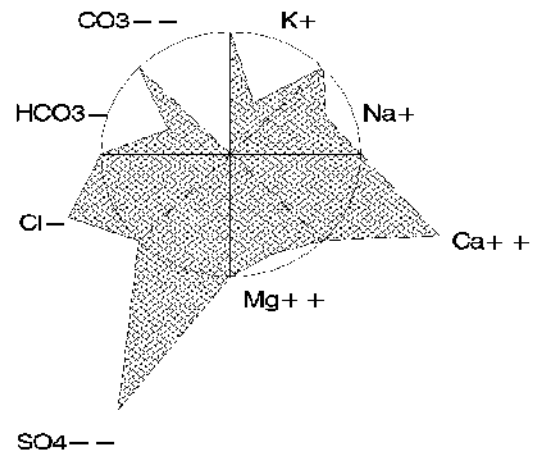

Lost Lake

Highlands County

USGS Quadrangle: Lake Placid Major Land Use/Land Cover (1990)
 Section/Township/Range: 12-37S-29E within 500 meters of the lakeshore:
 Approx. Lake Center, Lat/Long: 271622/812216 - tree crops, typically citrus (90%)
 Surface Area: 20 acres - hardwood - conifer mixed (9%)
 Approx. Lake Elevation: 80 feet - low density residential (1%)
 Lake Type: isolated (type 4)
 Major Basin: Kissimmee Ridge
 Minor Basin: Grassy Creek
 Lake Region: Southern Lake Wales Ridge

Total Number of Samples Collected: 3 Most Recent Sample Collected: January 1995

Parameter	Units (Detection Limit)	Average Value	District Percentile	Florida Percentile
Chlorophyll a	ug/l (1)	1.6	7	6
Total Phosphorus	mg/l as P (0.01)	0.009	31	<5
Total Nitrogen	mg/l as N (0.06)	5.44	>95	>95
Transparency (Secchi depth)	meters	6.00	>95	>95
Florida Trophic State Index		18	<5	<5
Specific Conductance	S/cm at 25C (1)	311	90	70
pH	standard units (0.1)	6.3	10	13
Color	PtCo units (1)	5	9	5
Turbidity	NTU (1)	0.5	28	<5
Total Alkalinity	mg/l as CaCO3 (1)	5	13	13
Hardness	mg/l as CaCO3 (0.02)	113	93	
Total Suspended Solids	mg/l (0.05)	0.4	8	
Ammonia	mg/l as N (0.03)	0.015	60	
Nitrate+Nitrite	mg/l as N (0.01)	5.046	>95	
Total Kjeldahl Nitrogen	mg/l as N (0.06)	0.40	<5	
Orthophosphorus	mg/l as P (0.01)	0.008	56	
Chloride	mg/l (0.05)	24	74	
Sulfate	mg/l (0.05)	50	93	
Sodium	mg/l (0.06)	6.5	27	
Potassium	mg/l (0.07)	12.7	94	
Calcium	mg/l (0.04)	24.0	86	
Magnesium	mg/l (0.006)	11.7	91	
Iron	ug/l (0.03)	17	13	

Based upon the average FTSI of 18, water quality is considered good. Lost Lake can be characterized as a clear (color<=10 color units), medium hard water, oligotrophic lake, with low concentrations of total phosphorus, high concentrations of total nitrogen and very high nitrate concentrations. The chemical type of water (predominant ionic composition) is calcium sulfate.

Also of note:

- Melaleuca was observed on the lake shore.

Plots and Trends: No or insufficient data available for plotting or trend detection. Shown is a diagram of the relative ionic composition of the lake water.

MAJOR IONS (% meq/l)

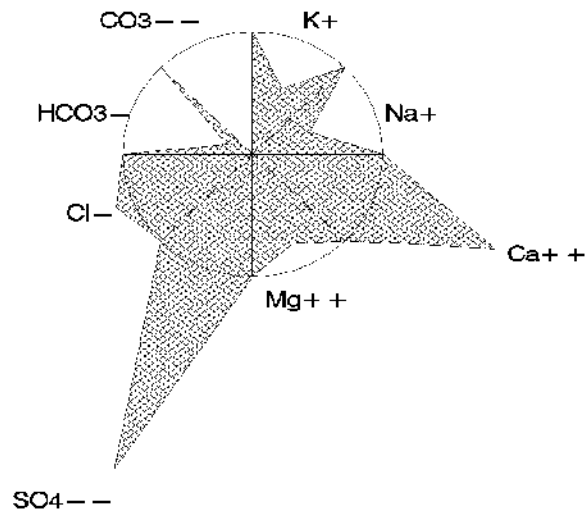

Lake Lotela

Highlands County

USGS Quadrangle: Lake Arbuckle SW Major Land Use/Land Cover (1990)
 Section/Township/Range: 26-33S-28E within 500 meters of the lakeshore:
 Approx. Lake Center, Lat/Long: 273438/812855 - medium density residential (32%)
 Surface Area: 802 acres - tree crops, typically citrus (26%)
 Approx. Lake Elevation: 109 feet - recreational (9%)
 Average Depth: 14.1 feet
 Observed Maximum Depth: 25 feet
 (reference elevation 101.8 feet)
 Lake Type: inflow and outflow (type 3)
 Major Basin: Kissimmee Ridge
 Minor Basin: Carter Creek
 Lake Region: Southern Lake Wales Ridge
 Public Access: yes

Total Number of Samples Collected: 10 Most Recent Sample Collected: April 1994

Parameter	Units (Detection Limit)	Average Value	District Percentile	Florida Percentile
Chlorophyll a	ug/l (1)	24.6	83	58
Total Phosphorus	mg/l as P (0.01)	0.016	56	8
Total Nitrogen	mg/l as N (0.06)	0.73	20	22
Transparency (Secchi depth)	meters	2.34	73	90
Florida Trophic State Index		38	49	13
Specific Conductance	S/cm at 25C (1)	143	33	40
pH	standard units (0.1)	6.9	29	28
Color	PtCo units (1)	4	<5	<5
Turbidity	NTU (1)	1.6	44	14
Total Alkalinity	mg/l as CaCO3 (1)	4	10	10
Hardness	mg/l as CaCO3 (0.02)	22	11	
Total Suspended Solids	mg/l (0.05)	2.6	60	
Ammonia	mg/l as N (0.03)	0.015	60	
Nitrate+Nitrite	mg/l as N (0.01)	0.099	82	
Total Kjeldahl Nitrogen	mg/l as N (0.06)	0.63	18	
Orthophosphorus	mg/l as P (0.01)	0.005	56	
Chloride	mg/l (0.05)	16	37	
Sulfate	mg/l (0.05)	6	23	
Sodium	mg/l (0.06)	5.3	15	
Potassium	mg/l (0.07)	3.2	48	
Calcium	mg/l (0.04)	1.6	<5	
Magnesium	mg/l (0.006)	4.5	63	
Iron	ug/l (0.03)	15	10	

Based upon the average FTSI of 38, water quality is considered good. Lake Lotela can be characterized as a clear (color<=10 color units), soft water, mesotrophic lake, with low concentrations of total nitrogen. The chemical type of water (predominant ionic composition) is sodium sulfate.

Plots and Trends: Lake elevations remained high during the first half of the period of record (1950 to 1969). In the early 1970s, lake levels rapidly declined and remained generally low until 1998. More recent levels (through February 1999, not shown) have remained above 106 feet. Also shown is a diagram of the relative ionic composition of the lake water.

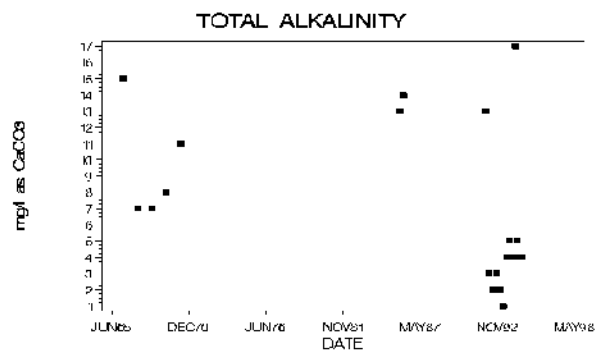
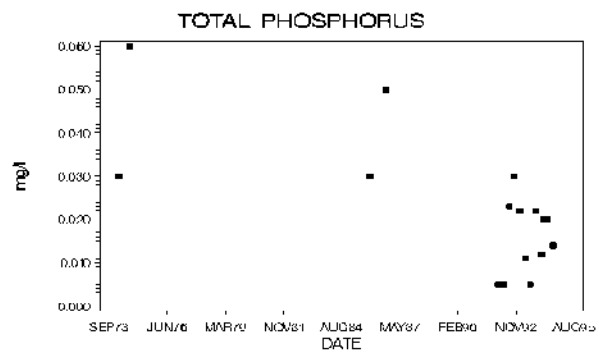
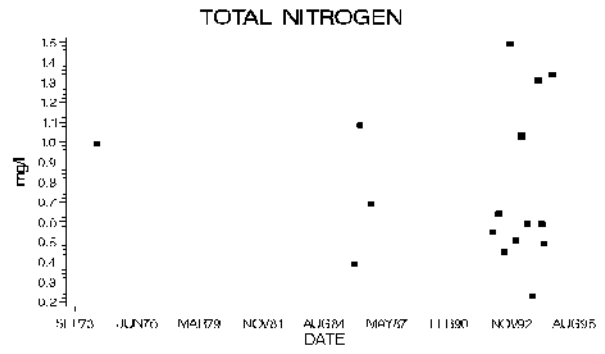
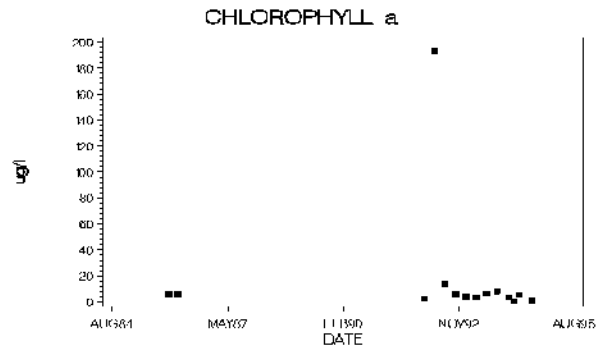
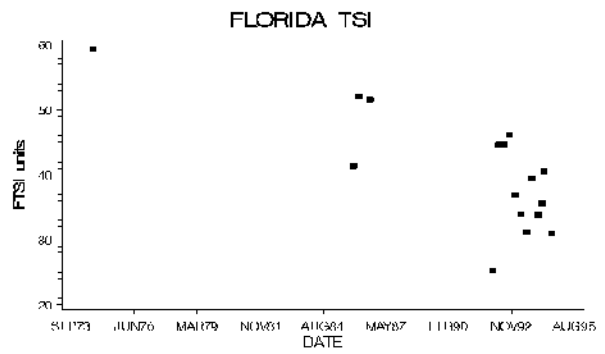
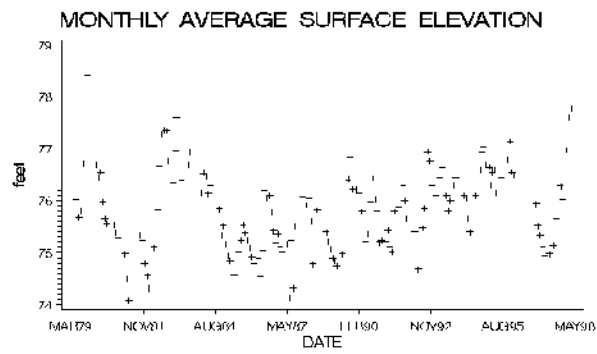

MAJOR IONS (% meq/l)

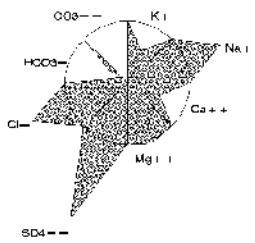

Lake Lotela, Highlands County

Lake Lucas

Highlands County

USGS Quadrangle: Lake Arbuckle SW Major Land Use/Land Cover (1990)
 Section/Township/Range: 21-34S-29E within 500 meters of the lakeshore:
 Approx. Lake Center, Lat/Long: 273043/812521 - cropland and pastureland (22%)
 Surface Area: 10 acres - wetland forested mixed (19%)
 Approx. Lake Elevation: 103 feet - open land (18%)
 Lake Type: isolated (type 4)
 Major Basin: Kissimmee Ridge
 Minor Basin: Arbuckle Creek
 Lake Region: Lake Wales Ridge Transition

Total Number of Samples Collected: 2 Most Recent Sample Collected: January 1996

Parameter	Units (Detection Limit)	Average Value	District Percentile	Florida Percentile
Chlorophyll a	ug/l (1)	10.5	66	39
Total Phosphorus	mg/l as P (0.01)	0.010	33	5
Total Nitrogen	mg/l as N (0.06)	0.84	28	27
Transparency (Secchi depth)	meters	0.80	24	50
Florida Trophic State Index		46	65	27
Specific Conductance	S/cm at 25C (1)	616	>95	84
pH	standard units (0.1)	6.6	18	20
Color	PtCo units (1)	85	86	70
Turbidity	NTU (1)	1.5	41	13
Total Alkalinity	mg/l as CaCO3 (1)	15	36	33
Hardness	mg/l as CaCO3 (0.02)	16	6	
Total Suspended Solids	mg/l (0.05)	1.6	42	
Ammonia	mg/l as N (0.03)	0.118	90	
Nitrate+Nitrite	mg/l as N (0.01)	0.012	40	
Total Kjeldahl Nitrogen	mg/l as N (0.06)	0.83	34	
Orthophosphorus	mg/l as P (0.01)	0.005	56	
Chloride	mg/l (0.05)	8	9	
Sulfate	mg/l (0.05)	2	10	
Sodium	mg/l (0.06)	6.2	24	
Potassium	mg/l (0.07)	0.4	9	
Calcium	mg/l (0.04)	4.2	9	
Magnesium	mg/l (0.006)	1.3	12	
Iron	ug/l (0.03)	507	>95	

Based upon the average FTSI of 46, water quality is considered good. Lake Lucas can be characterized as a highly colored, soft water, meso-eutrophic lake. The chemical type of water (predominant ionic composition) is sodium chloride.

Also of note:

- Cattails dominate more than 30% of the lake shoreline.

Plots and Trends: Shown is a diagram of the relative ionic composition of the lake water.

MAJOR IONS (% meq/l)

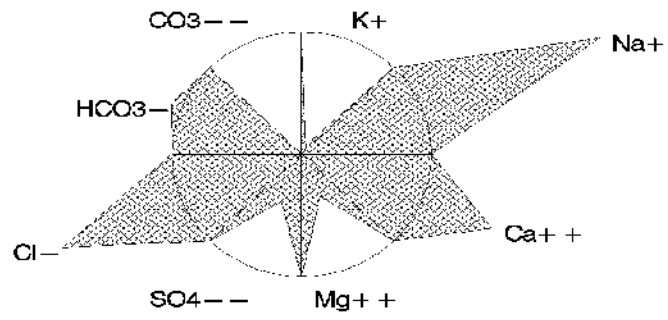

Lake Lynn

Highlands County

USGS Quadrangle: Sebring Major Land Use/Land Cover (1990)
 Section/Township/Range: 35-35S-29E within 500 meters of the lakeshore:
 Approx. Lake Center, Lat/Long: 272342/812348 - tree crops, typically citrus (89%)
 Surface Area: 16 acres - low density residential (8%)
 Approx. Lake Elevation: 61 feet - freshwater marshes (1%)
 Lake Type: isolated (type 4)
 Major Basin: Kissimmee Ridge
 Minor Basin: Josephine Creek
 Lake Region: Southern Lake Wales Ridge

Total Number of Samples Collected: 2 Most Recent Sample Collected: January 1996

Parameter	Units (Detection Limit)	Average Value	District Percentile	Florida Percentile
Chlorophyll a	ug/l (1)	0.8	<5	<5
Total Phosphorus	mg/l as P (0.01)	0.009	31	<5
Total Nitrogen	mg/l as N (0.06)	4.73	>95	>95
Transparency (Secchi depth)	meters	3.70	92	>95
Florida Trophic State Index		19	5	<5
Specific Conductance	S/cm at 25C (1)	342	92	72
pH	standard units (0.1)	8.2	85	75
Color	PtCo units (1)	5	9	5
Turbidity	NTU (1)	0.5	28	<5
Total Alkalinity	mg/l as CaCO3 (1)	55	83	65
Hardness	mg/l as CaCO3 (0.02)	127	95	
Total Suspended Solids	mg/l (0.05)	0.6	15	
Ammonia	mg/l as N (0.03)	0.062	80	
Nitrate+Nitrite	mg/l as N (0.01)	4.610	>95	
Total Kjeldahl Nitrogen	mg/l as N (0.06)	0.13	<5	
Orthophosphorus	mg/l as P (0.01)	0.005	56	
Chloride	mg/l (0.05)	29	83	
Sulfate	mg/l (0.05)	44	91	
Sodium	mg/l (0.06)	7.3	36	
Potassium	mg/l (0.07)	13.0	94	
Calcium	mg/l (0.04)	19.5	74	
Magnesium	mg/l (0.006)	19.0	>95	
Iron	ug/l (0.03)	21	22	

Based upon the average FTSI of 19, water quality is considered good. Lake Lynn can be characterized as a clear (color<=10 color units), hard water, oligotrophic lake, with low concentrations of total phosphorus, high concentrations of total nitrogen and very high nitrate concentrations. The chemical type of water (predominant ionic composition) is calcium sulfate.

Also of note:

- The measured pH was high.

Plots and Trends: No or insufficient data available for plotting or trend detection. Shown is a diagram of the relative ionic composition of the lake water.

MAJOR IONS (% meq/l)

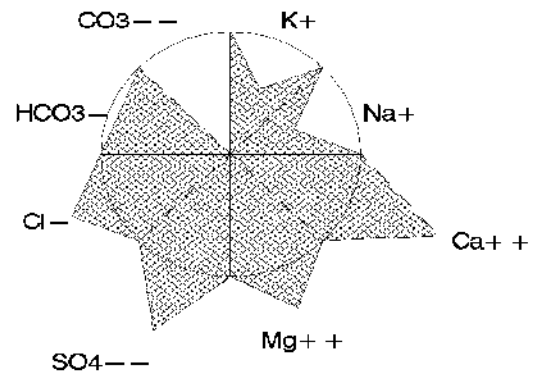

Lake McCoy

Highlands County

USGS Quadrangle: Lake Placid Major Land Use/Land Cover (1990)
 Section/Township/Range: 6-37S-30E within 500 meters of the lakeshore:
 Approx. Lake Center, Lat/Long: 271702/812115 - tree crops, typically citrus (46%)
 Surface Area: 56 acres - medium density residential (31%)
 Approx. Lake Elevation: 87 feet - transportation (8%)
 Average Depth: 27.6 feet
 Observed Maximum Depth: 61 feet
 (reference elevation 85 feet)
 Lake Type: isolated (type 4)
 Major Basin: Kissimmee Ridge
 Minor Basin: Grassy Creek
 Lake Region: Southern Lake Wales Ridge

Total Number of Samples Collected: 2 Most Recent Sample Collected: January 1996

Parameter	Units (Detection Limit)	Average Value	District Percentile	Florida Percentile
Chlorophyll a	ug/l (1)	1.4	<5	<5
Total Phosphorus	mg/l as P (0.01)	0.008	31	<5
Total Nitrogen	mg/l as N (0.06)	1.10	48	37
Transparency (Secchi depth)	meters	3.00	84	>95
Florida Trophic State Index		25	15	<5
Specific Conductance	S/cm at 25C (1)	183	52	49
pH	standard units (0.1)	7.7	69	60
Color	PtCo units (1)	5	9	5
Turbidity	NTU (1)	0.5	28	<5
Total Alkalinity	mg/l as CaCO3 (1)	23	46	42
Hardness	mg/l as CaCO3 (0.02)	55	56	
Total Suspended Solids	mg/l (0.05)	0.6	15	
Ammonia	mg/l as N (0.03)	0.050	75	
Nitrate+Nitrite	mg/l as N (0.01)	0.674	93	
Total Kjeldahl Nitrogen	mg/l as N (0.06)	0.43	5	
Orthophosphorus	mg/l as P (0.01)	0.005	56	
Chloride	mg/l (0.05)	17	41	
Sulfate	mg/l (0.05)	32	81	
Sodium	mg/l (0.06)	8.0	44	
Potassium	mg/l (0.07)	6.5	78	
Calcium	mg/l (0.04)	12.5	51	
Magnesium	mg/l (0.006)	5.7	75	
Iron	ug/l (0.03)	24	29	

Based upon the average FTSI of 25, water quality is considered good. Lake McCoy can be characterized as a clear (color<=10 color units), soft water, oligotrophic lake, with low concentrations of total phosphorus. The chemical type of water (predominant ionic composition) is calcium sulfate.

Plots and Trends: The period of record for lake surface elevation is interrupted for a twenty year period between 1966 and 1986. Recent levels appear to be returning to levels typical of the 1950s and 1960s. Also shown is a diagram of the relative ionic composition of the lake water.

MONTHLY AVERAGE SURFACE ELEVATION

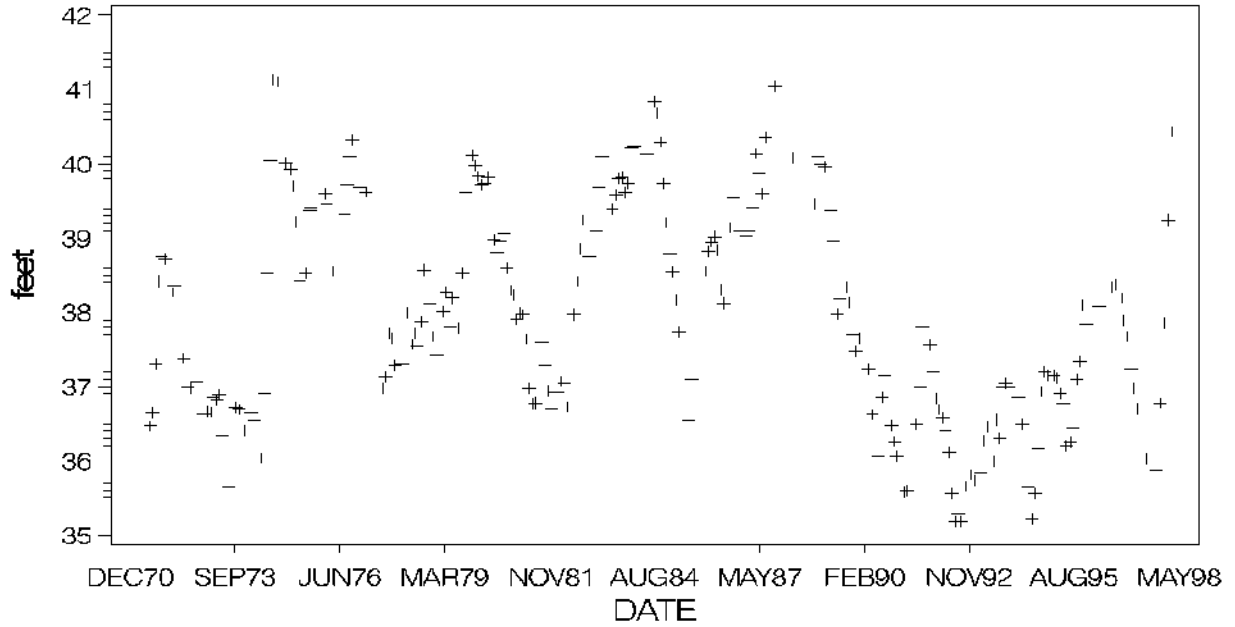

MAJOR IONS (% meq/l)

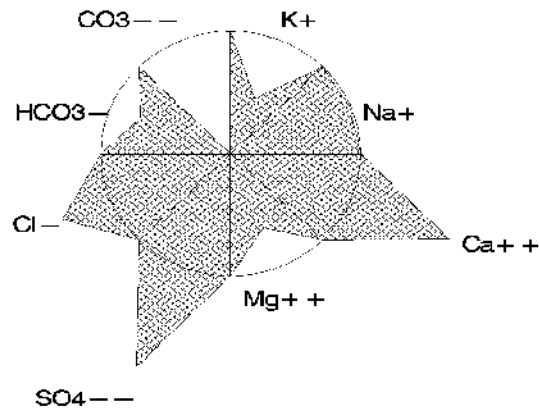

Mirror Lake

Highlands County

USGS Quadrangle: Lake Placid Major Land Use/Land Cover (1990)
 Section/Township/Range: 7-37S-30E within 500 meters of the lakeshore:
 Approx. Lake Center, Lat/Long: 271631/812139 - tree crops, typically citrus (48%)
 Surface Area: 97 acres - hardwood - conifer mixed (14%)
 Approx. Lake Elevation: 94 feet - medium density residential (11%)
 Average Depth: 21 feet
 Observed Maximum Depth: 41 feet
 (reference elevation 92 feet)
 Lake Type: inflow (type 1)
 Major Basin: Kissimmee Ridge
 Minor Basin: Lake Francis Outlet
 Lake Region: Southern Lake Wales Ridge

Total Number of Samples Collected: 2 Most Recent Sample Collected: January 1995

Parameter	Units (Detection Limit)	Average Value	District Percentile	Florida Percentile
Chlorophyll a	ug/l (1)	1.9	11	8
Total Phosphorus	mg/l as P (0.01)	0.005	31	<5
Total Nitrogen	mg/l as N (0.06)	0.53	6	12
Transparency (Secchi depth)	meters	4.55	>95	>95
Florida Trophic State Index		13	<5	<5
Specific Conductance	S/cm at 25C (1)	105	14	25
pH	standard units (0.1)	6.5	15	18
Color	PtCo units (1)	5	9	5
Turbidity	NTU (1)	0.5	28	<5
Total Alkalinity	mg/l as CaCO3 (1)	3	7	8
Hardness	mg/l as CaCO3 (0.02)	21	10	
Total Suspended Solids	mg/l (0.05)	1.0	28	
Ammonia	mg/l as N (0.03)	0.015	60	
Nitrate+Nitrite	mg/l as N (0.01)	0.021	53	
Total Kjeldahl Nitrogen	mg/l as N (0.06)	0.53	10	
Orthophosphorus	mg/l as P (0.01)	0.010	59	
Chloride	mg/l (0.05)	14	30	
Sulfate	mg/l (0.05)	17	54	
Sodium	mg/l (0.06)	5.9	21	
Potassium	mg/l (0.07)	3.8	52	
Calcium	mg/l (0.04)	2.5	<5	
Magnesium	mg/l (0.006)	3.7	55	
Iron	ug/l (0.03)	11	<5	

Based upon the average FTSI of 13, water quality is considered good. Mirror Lake can be characterized as a clear (color<=10 color units), soft water, oligotrophic lake, with low concentrations of total phosphorus, very low concentrations of total nitrogen. The chemical type of water (predominant ionic composition) is sodium chloride.

Plots and Trends: No or insufficient data available for plotting or trend detection. Shown is a diagram of the relative ionic composition of the lake water.

MONTHLY AVERAGE SURFACE ELEVATION

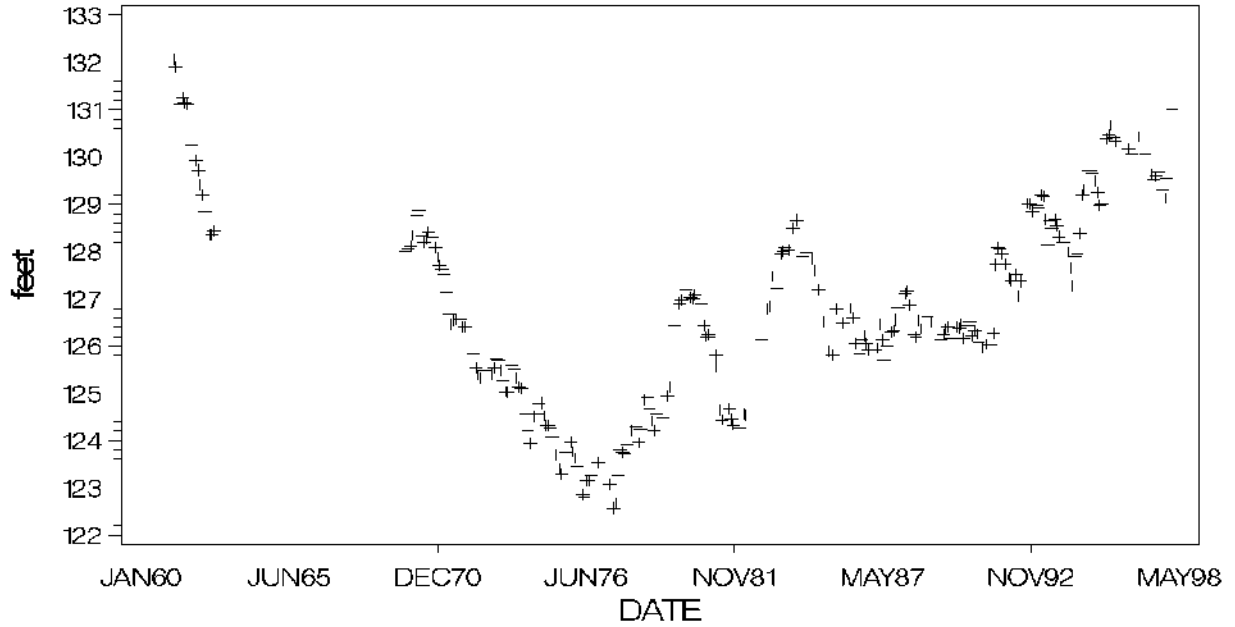

MAJOR IONS (% meq/l)

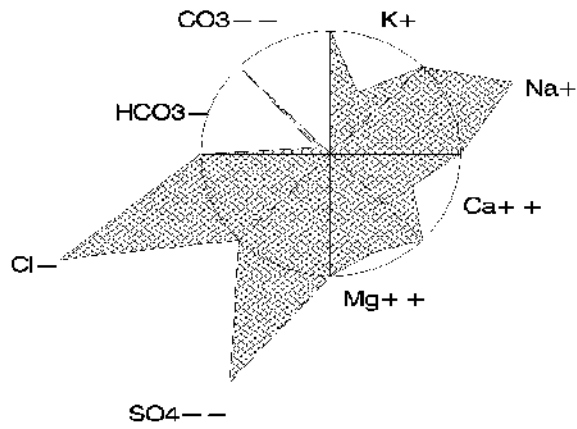

Lake Nellie SE Highlands County

USGS Quadrangle: Lake June-in-Winter
 Section/Township/Range: 13-36S-29E
 Approx. Lake Center, Lat/Long: 272053/812233
 Surface Area: 29 acres
 Approx. Lake Elevation: 71 feet
 Lake Type: inflow and outflow (type 3)
 Major Basin: Kissimmee Ridge
 Minor Basin: Lake Francis Outlet
 Lake Region: Southern Lake Wales Ridge

Major Land Use/Land Cover (1990)
 within 500 meters of the lakeshore:
 - tree crops, typically citrus (91%)
 - cropland and pastureland (9%)
 - other open lands - rural (1%)

Total Number of Samples Collected: 5 Most Recent Sample Collected: January 1996

Parameter	Units (Detection Limit)	Average Value	District Percentile	Florida Percentile
Chlorophyll a	ug/l (1)	4.6	41	19
Total Phosphorus	mg/l as P (0.01)	0.005	31	<5
Total Nitrogen	mg/l as N (0.06)	4.13	>95	>95
Transparency (Secchi depth)	meters	3.06	86	>95
Florida Trophic State Index		29	25	<5
Specific Conductance	S/cm at 25C (1)	391	95	75
pH	standard units (0.1)	7.4	57	50
Color	PtCo units (1)	5	9	5
Turbidity	NTU (1)	1.8	47	17
Total Alkalinity	mg/l as CaCO3 (1)	20	42	39
Hardness	mg/l as CaCO3 (0.02)	131	>95	
Total Suspended Solids	mg/l (0.05)	1.6	42	
Ammonia	mg/l as N (0.03)	0.023	60	
Nitrate+Nitrite	mg/l as N (0.01)	3.422	>95	
Total Kjeldahl Nitrogen	mg/l as N (0.06)	0.71	24	
Orthophosphorus	mg/l as P (0.01)	0.005	56	
Chloride	mg/l (0.05)	34	90	
Sulfate	mg/l (0.05)	76	>95	
Sodium	mg/l (0.06)	10.8	63	
Potassium	mg/l (0.07)	14.2	>95	
Calcium	mg/l (0.04)	27.0	89	
Magnesium	mg/l (0.006)	15.6	>95	
Iron	ug/l (0.03)	13	7	

Based upon the average FTSI of 29, water quality is considered good. Lake Nellie SE can be characterized as a clear (color<=10 color units), hard water, oligo-mesotrophic lake, with low concentrations of total phosphorus, high concentrations of total nitrogen and very high nitrate concentrations. The chemical type of water (predominant ionic composition) is calcium sulfate.

Also of note:

- Melaleuca was observed on the lake shore.

Plots and Trends: The lake elevations shown are for the Lake Nellie group of lakes. Also shown is a diagram of the relative ionic composition of the lake water.

MONTHLY AVERAGE SURFACE ELEVATION

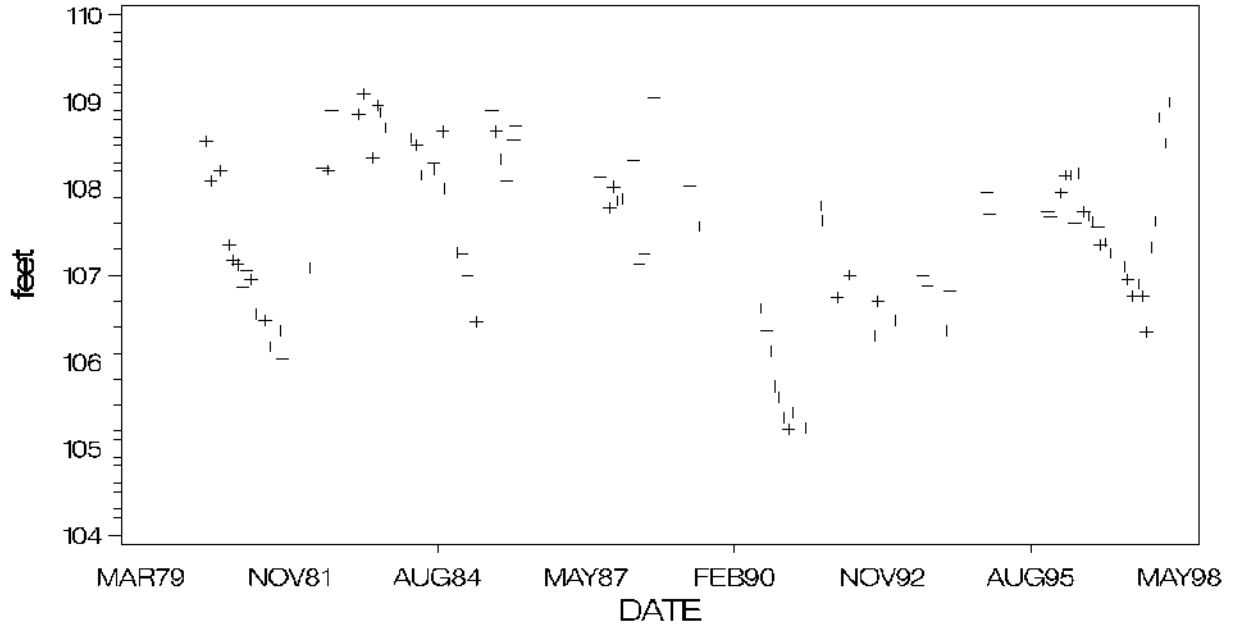

MAJOR IONS (% meq/l)

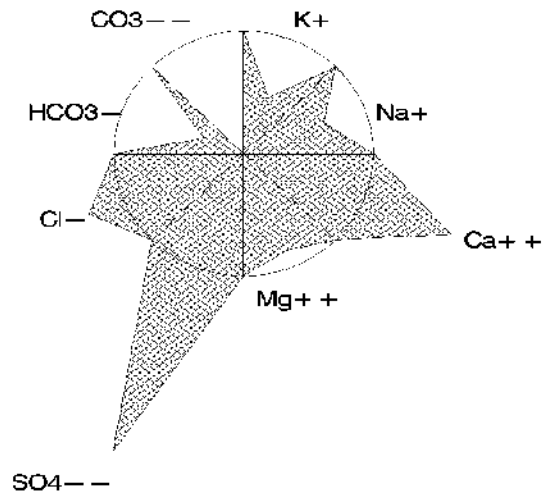

Lake Nellie Center Highlands County

USGS Quadrangle: Lake June-in-Winter
 Section/Township/Range: 13-36S-29E
 Approx. Lake Center, Lat/Long: 272109/812243
 Surface Area: 43 acres
 Approx. Lake Elevation: 71 feet
 Lake Type: inflow and outflow (type 3)
 Major Basin: Kissimmee Ridge
 Minor Basin: Lake Francis Outlet
 Lake Region: Southern Lake Wales Ridge

Major Land Use/Land Cover (1990)
 within 500 meters of the lakeshore:
 - tree crops, typically citrus (82%)
 - cropland and pastureland (13%)
 - other open lands - rural (4%)

Total Number of Samples Collected: 3 Most Recent Sample Collected: January 1996

Parameter	Units (Detection Limit)	Average Value	District Percentile	Florida Percentile
Chlorophyll a	ug/l (1)	11.0	68	40
Total Phosphorus	mg/l as P (0.01)	0.013	46	7
Total Nitrogen	mg/l as N (0.06)	1.41	67	51
Transparency (Secchi depth)	meters	1.08	37	66
Florida Trophic State Index		52	76	39
Specific Conductance	S/cm at 25C (1)	352	93	73
pH	standard units (0.1)	7.8	74	63
Color	PtCo units (1)	5	9	5
Turbidity	NTU (1)	6.5	79	58
Total Alkalinity	mg/l as CaCO3 (1)	25	50	44
Hardness	mg/l as CaCO3 (0.02)	114	94	
Total Suspended Solids	mg/l (0.05)	3.9	72	
Ammonia	mg/l as N (0.03)	0.054	78	
Nitrate+Nitrite	mg/l as N (0.01)	0.077	78	
Total Kjeldahl Nitrogen	mg/l as N (0.06)	1.33	70	
Orthophosphorus	mg/l as P (0.01)	0.012	68	
Chloride	mg/l (0.05)	31	87	
Sulfate	mg/l (0.05)	57	95	
Sodium	mg/l (0.06)	10.4	60	
Potassium	mg/l (0.07)	14.7	>95	
Calcium	mg/l (0.04)	24.0	86	
Magnesium	mg/l (0.006)	13.3	94	
Iron	ug/l (0.03)	20	20	

Based upon the average FTSI of 52, water quality is considered good. Lake Nellie Center can be characterized as a clear (color<=10 color units), medium hard water, eutrophic lake. The chemical type of water (predominant ionic composition) is calcium sulfate.

Also of note:

- Melaleuca was observed on the lake shore.

Plots and Trends: The lake elevations shown are for the Lake Nellie group of lakes. Also shown is a diagram of the relative ionic composition of the lake water.

MONTHLY AVERAGE SURFACE ELEVATION

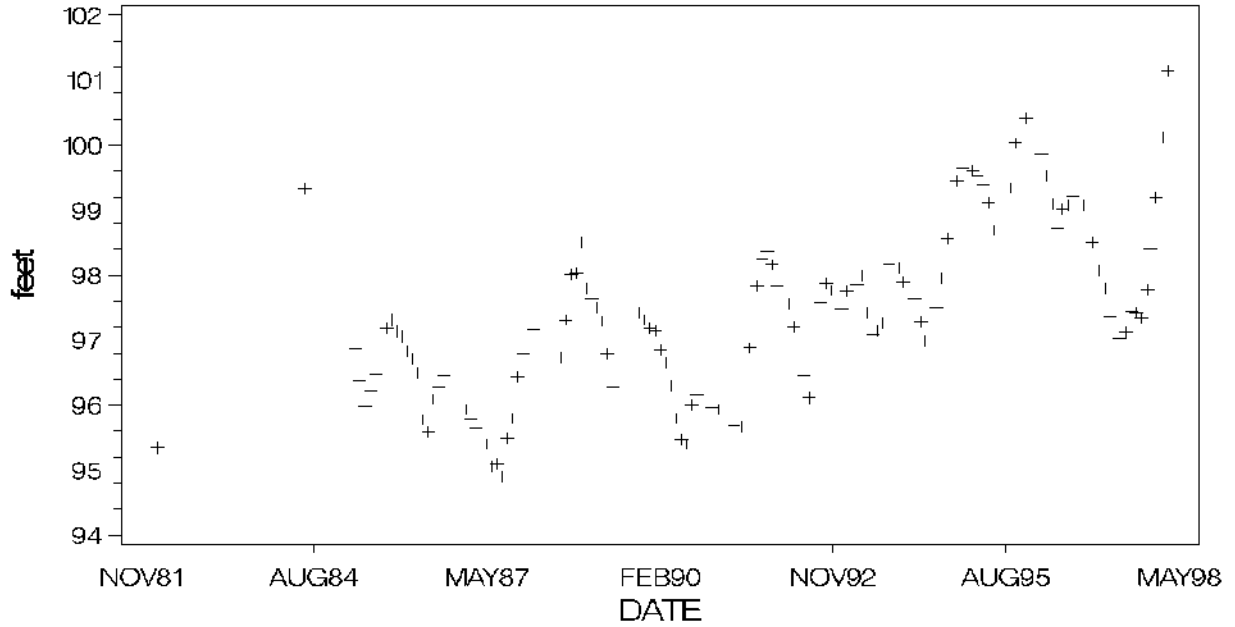

MAJOR IONS (% meq/l)

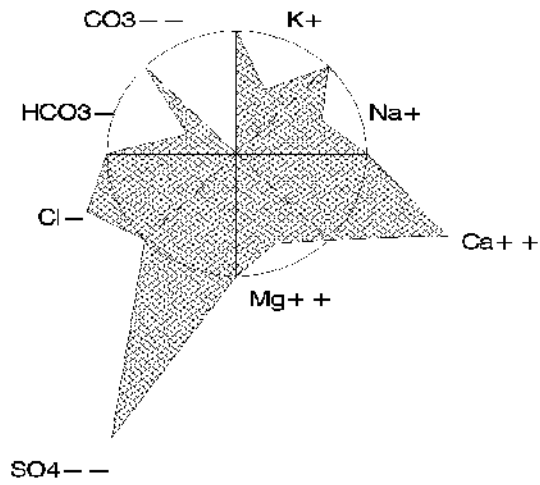

Lake Nellie NW Highlands County

USGS Quadrangle: Lake June-in-Winter
 Section/Township/Range: 13-36S-29E
 Approx. Lake Center, Lat/Long: 272112/812300
 Surface Area: 21 acres
 Approx. Lake Elevation: 71 feet
 Lake Type: inflow and outflow (type 3)
 Major Basin: Kissimmee Ridge
 Minor Basin: Lake Francis Outlet
 Lake Region: Southern Lake Wales Ridge

Major Land Use/Land Cover (1990)
 within 500 meters of the lakeshore:
 - tree crops, typically citrus (71%)
 - cropland and pastureland (23%)
 - transportation (4%)

Total Number of Samples Collected: 3 Most Recent Sample Collected: January 1996

Parameter	Units (Detection Limit)	Average Value	District Percentile	Florida Percentile
Chlorophyll a	ug/l (1)	12.8	71	42
Total Phosphorus	mg/l as P (0.01)	0.012	41	6
Total Nitrogen	mg/l as N (0.06)	1.17	53	39
Transparency (Secchi depth)	meters	0.85	26	55
Florida Trophic State Index		53	77	42
Specific Conductance	S/cm at 25C (1)	339	91	72
pH	standard units (0.1)	7.7	69	60
Color	PtCo units (1)	5	9	5
Turbidity	NTU (1)	7.3	82	61
Total Alkalinity	mg/l as CaCO3 (1)	25	50	44
Hardness	mg/l as CaCO3 (0.02)	108	93	
Total Suspended Solids	mg/l (0.05)	4.4	75	
Ammonia	mg/l as N (0.03)	0.078	84	
Nitrate+Nitrite	mg/l as N (0.01)	0.110	83	
Total Kjeldahl Nitrogen	mg/l as N (0.06)	1.07	53	
Orthophosphorus	mg/l as P (0.01)	0.010	59	
Chloride	mg/l (0.05)	30	85	
Sulfate	mg/l (0.05)	54	94	
Sodium	mg/l (0.06)	10.0	58	
Potassium	mg/l (0.07)	14.0	>95	
Calcium	mg/l (0.04)	22.7	83	
Magnesium	mg/l (0.006)	12.7	93	
Iron	ug/l (0.03)	21	23	

Based upon the average FTSI of 53, water quality is considered good. Lake Nellie NW can be characterized as a clear (color<=10 color units), medium hard water, eutrophic lake. The chemical type of water (predominant ionic composition) is calcium sulfate.

Also of note:

- Melaleuca was observed on the lake shore. -

Plots and Trends: The lake elevations shown are for the Lake Nellie group of lakes. Also shown is a diagram of the relative ionic composition of the lake water.

MONTHLY AVERAGE SURFACE ELEVATION

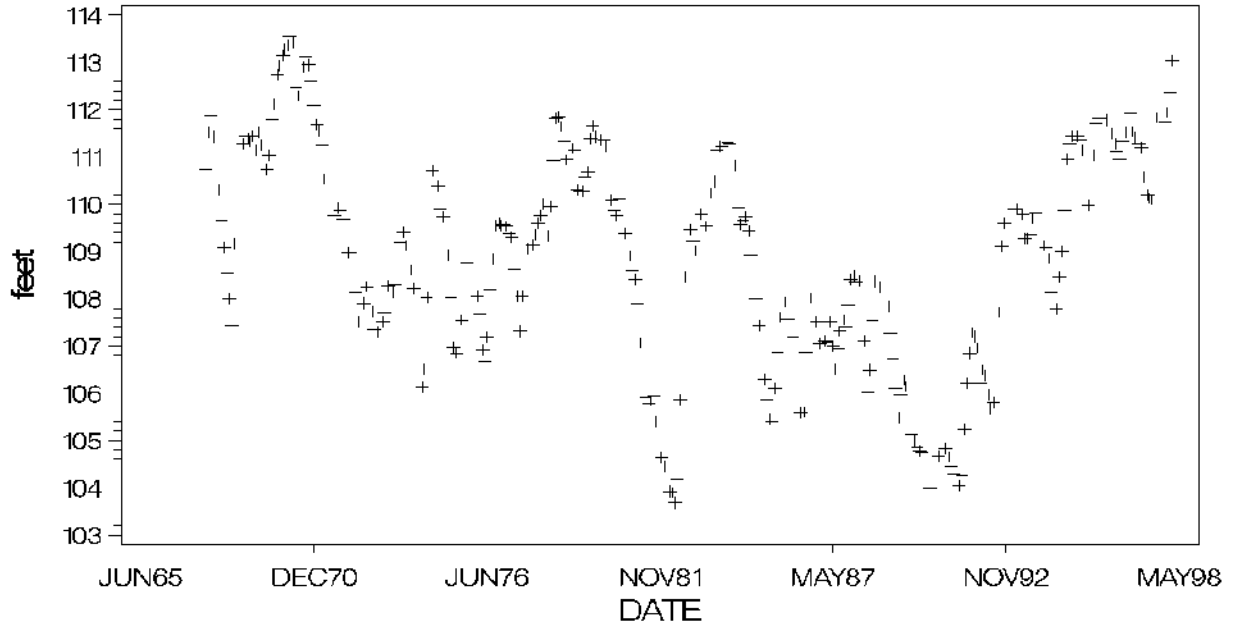

MAJOR IONS (% meq/l)

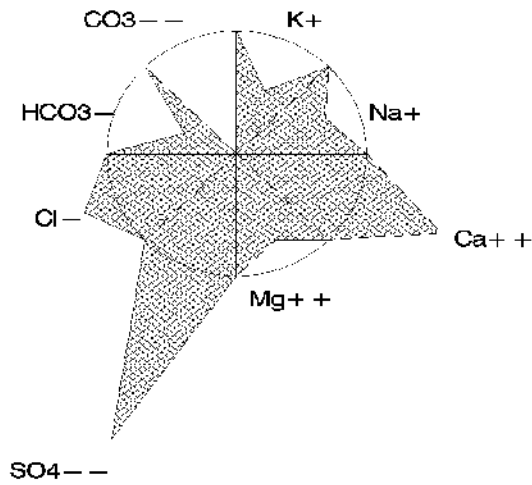

Lake Olivia

Highlands County

USGS Quadrangle: Frostproof Major Land Use/Land Cover (1990)
 Section/Township/Range: 6-33S-28E within 500 meters of the lakeshore:
 Approx. Lake Center, Lat/Long: 273757/813251 - medium density residential (58%)
 Surface Area: 86 acres - low density residential (26%)
 Approx. Lake Elevation: 118 feet - cropland and pastureland (11%)
 Average Depth: 16.4 feet
 Observed Maximum Depth: 41 feet
 (reference elevation 92.94 feet)
 Lake Type: isolated (type 4)
 Major Basin: Kissimmee Ridge
 Minor Basin: Livingston Creek
 Lake Region: Southern Lake Wales Ridge
 Public Access: yes

Total Number of Samples Collected: 2 Most Recent Sample Collected: January 1995

Parameter	Units (Detection Limit)	Average Value	District Percentile	Florida Percentile
Chlorophyll a	ug/l (1)	2.4	17	10
Total Phosphorus	mg/l as P (0.01)	0.009	31	<5
Total Nitrogen	mg/l as N (0.06)	0.60	8	15
Transparency (Secchi depth)	meters	3.25	88	>95
Florida Trophic State Index		26	19	<5
Specific Conductance	S/cm at 25C (1)	78	6	15
pH	standard units (0.1)	6.4	12	15
Color	PtCo units (1)	8	24	8
Turbidity	NTU (1)	0.8	28	<5
Total Alkalinity	mg/l as CaCO3 (1)	7	18	20
Hardness	mg/l as CaCO3 (0.02)	18	8	
Total Suspended Solids	mg/l (0.05)	0.9	24	
Ammonia	mg/l as N (0.03)	0.015	60	
Nitrate+Nitrite	mg/l as N (0.01)	0.040	65	
Total Kjeldahl Nitrogen	mg/l as N (0.06)	0.56	12	
Orthophosphorus	mg/l as P (0.01)	0.014	76	
Chloride	mg/l (0.05)	8	9	
Sulfate	mg/l (0.05)	13	45	
Sodium	mg/l (0.06)	5.6	18	
Potassium	mg/l (0.07)	1.9	32	
Calcium	mg/l (0.04)	3.9	8	
Magnesium	mg/l (0.006)	2.0	25	
Iron	ug/l (0.03)	8	<5	

Based upon the average FTSI of 26, water quality is considered good. Lake Olivia can be characterized as a clear (color<=10 color units), soft water, oligotrophic lake, with low concentrations of total phosphorus, very low concentrations of total nitrogen. The chemical type of water (predominant ionic composition) is sodium sulfate.

Plots and Trends: The plot of lake elevation shows that lake level rose sharply in the mid-1990s, and again in 1998. Also shown is a diagram of the relative ionic composition of the lake water.

MONTHLY AVERAGE SURFACE ELEVATION

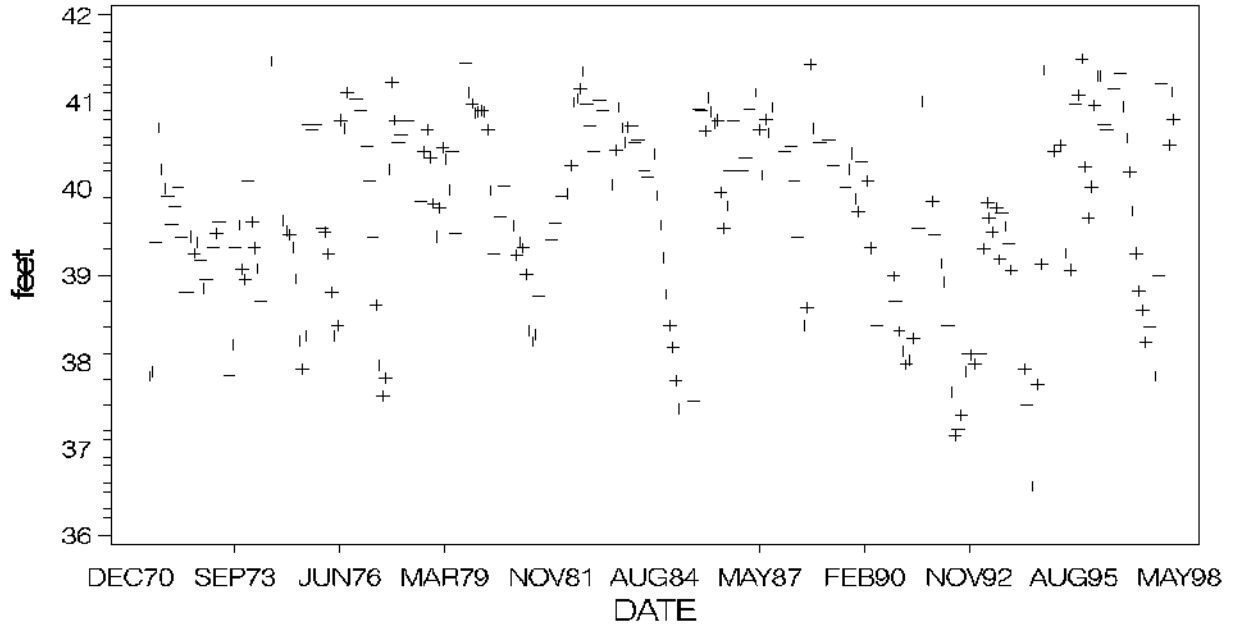

MAJOR IONS (% meq/l)

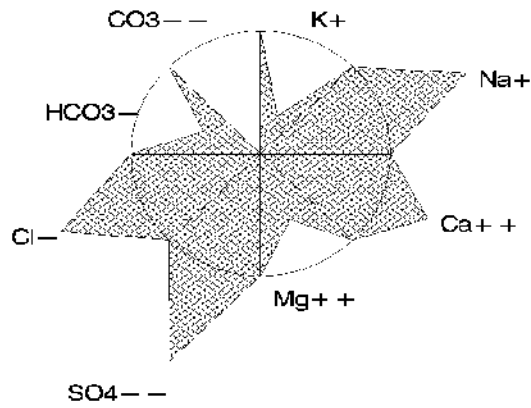

Pansy Lake

Highlands County

USGS Quadrangle: Frostproof Major Land Use/Land Cover (1990)
 Section/Township/Range: 3-33S-28E within 500 meters of the lakeshore:
 Approx. Lake Center, Lat/Long: 273831/813047 - tree crops, typically citrus (40%)
 Surface Area: 8 acres - low density residential (35%)
 Approx. Lake Elevation: 104 feet - recreational (14%)
 Lake Type: isolated (type 4)
 Major Basin: Kissimmee Ridge
 Minor Basin: Grassy Creek
 Lake Region: Southern Lake Wales Ridge

Total Number of Samples Collected: 2 Most Recent Sample Collected: January 1996

Parameter	Units (Detection Limit)	Average Value	District Percentile	Florida Percentile
Chlorophyll a	ug/l (1)	40.0	91	75
Total Phosphorus	mg/l as P (0.01)	0.031	77	21
Total Nitrogen	mg/l as N (0.06)	2.64	93	89
Transparency (Secchi depth)	meters	0.75	21	45
Florida Trophic State Index		63	88	62
Specific Conductance	S/cm at 25C (1)	258	79	61
pH	standard units (0.1)	8.6	92	85
Color	PtCo units (1)	10	34	10
Turbidity	NTU (1)	17.3	95	79
Total Alkalinity	mg/l as CaCO3 (1)	55	83	65
Hardness	mg/l as CaCO3 (0.02)	76	76	
Total Suspended Solids	mg/l (0.05)	10.8	92	
Ammonia	mg/l as N (0.03)	0.315	>95	
Nitrate+Nitrite	mg/l as N (0.01)	0.226	87	
Total Kjeldahl Nitrogen	mg/l as N (0.06)	2.42	95	
Orthophosphorus	mg/l as P (0.01)	0.032	91	
Chloride	mg/l (0.05)	15	34	
Sulfate	mg/l (0.05)	41	88	
Sodium	mg/l (0.06)	4.1	9	
Potassium	mg/l (0.07)	13.5	95	
Calcium	mg/l (0.04)	17.0	65	
Magnesium	mg/l (0.006)	8.2	84	
Iron	ug/l (0.03)	49	60	

Based upon the average FTSI of 63, water quality is considered fair. Pansy Lake can be characterized as a clear (color<=10 color units), medium hard water, eutrophic to hypereutrophic lake, with high concentrations of total nitrogen. The chemical type of water (predominant ionic composition) is calcium sulfate.

Also of note:

- The measured pH was high.

Plots and Trends: Shown are a plot of lake surface elevation, and a diagram of the relative ionic composition of the lake water.

MAJOR IONS (% meq/l)

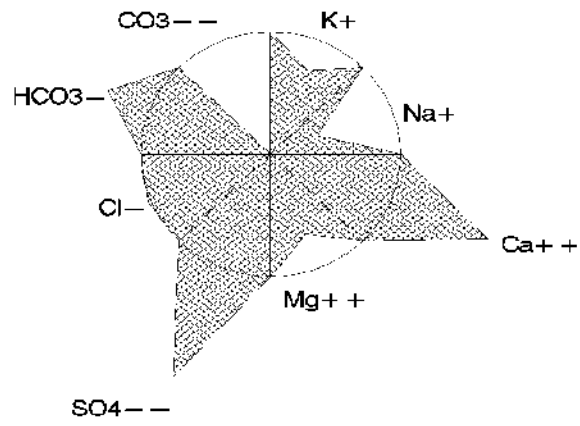

Lake Pearl Highlands County

USGS Quadrangle: Lake Placid
 Section/Township/Range: 6-37S-30E
 Approx. Lake Center, Lat/Long: 271700/812141
 Surface Area: 66 acres
 Approx. Lake Elevation: 87 feet
 Average Depth: 25 feet
 Observed Maximum Depth: 47 feet
 (reference elevation 83.4 feet)
 Lake Type: inflow and outflow (type 3)
 Major Basin: Kissimmee Ridge
 Minor Basin: Grassy Creek
 Lake Region: Southern Lake Wales Ridge

Major Land Use/Land Cover (1990)
 within 500 meters of the lakeshore:
 - medium density residential (45%)
 - tree crops, typically citrus (32%)
 - commercial and services (11%)

Total Number of Samples Collected: 2 Most Recent Sample Collected: January 1996

Parameter	Units (Detection Limit)	Average Value	District Percentile	Florida Percentile
Chlorophyll a	ug/l (1)	1.2	<5	<5
Total Phosphorus	mg/l as P (0.01)	0.010	33	5
Total Nitrogen	mg/l as N (0.06)	0.64	14	17
Transparency (Secchi depth)	meters	3.40	89	>95
Florida Trophic State Index		22	9	<5
Specific Conductance	S/cm at 25C (1)	146	35	41
pH	standard units (0.1)	7.0	34	30
Color	PtCo units (1)	5	9	5
Turbidity	NTU (1)	0.5	28	<5
Total Alkalinity	mg/l as CaCO3 (1)	11	29	27
Hardness	mg/l as CaCO3 (0.02)	38	32	
Total Suspended Solids	mg/l (0.05)	0.4	8	
Ammonia	mg/l as N (0.03)	0.045	71	
Nitrate+Nitrite	mg/l as N (0.01)	0.408	90	
Total Kjeldahl Nitrogen	mg/l as N (0.06)	0.24	<5	
Orthophosphorus	mg/l as P (0.01)	0.005	56	
Chloride	mg/l (0.05)	19	51	
Sulfate	mg/l (0.05)	26	72	
Sodium	mg/l (0.06)	7.2	35	
Potassium	mg/l (0.07)	5.2	67	
Calcium	mg/l (0.04)	8.5	30	
Magnesium	mg/l (0.006)	4.1	59	
Iron	ug/l (0.03)	37	49	

Based upon the average FTSI of 22, water quality is considered good. Lake Pearl can be characterized as a clear (color<=10 color units), soft water, oligotrophic lake, with low concentrations of total nitrogen. The chemical type of water (predominant ionic composition) is calcium chloride.

Also of note:

- Melaleuca was observed on the lake shore.

Plots and Trends: Shown are a plot of lake surface elevation and a diagram of the relative ionic composition of the lake water.

MONTHLY AVERAGE SURFACE ELEVATION

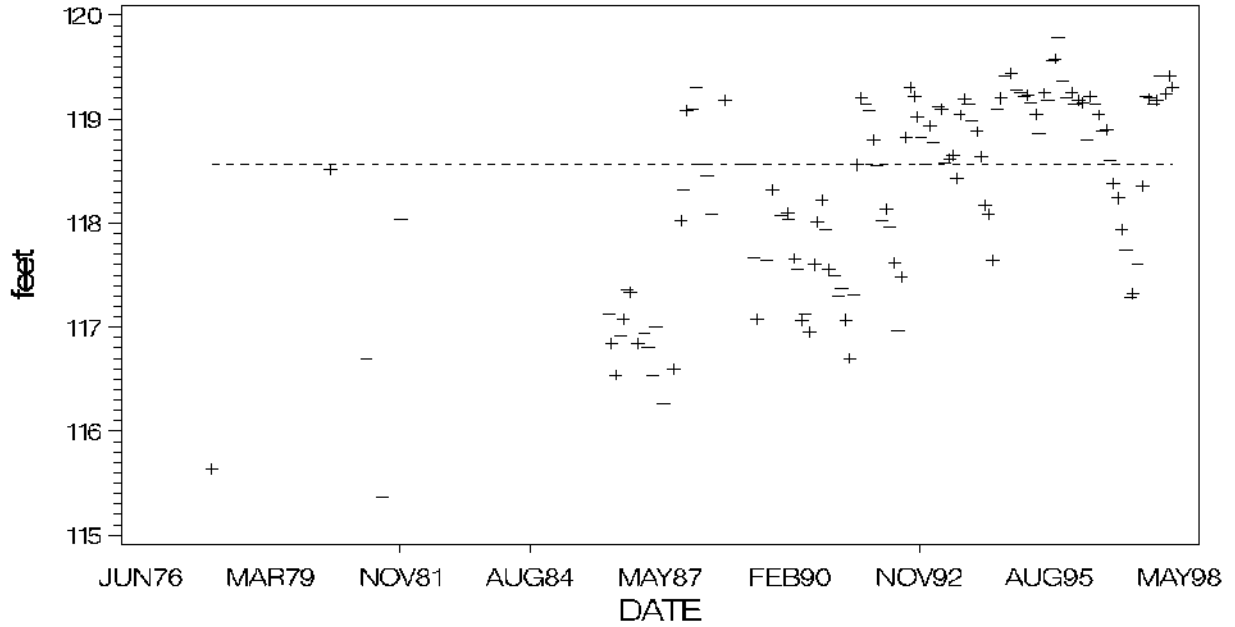

MAJOR IONS (% meq/l)

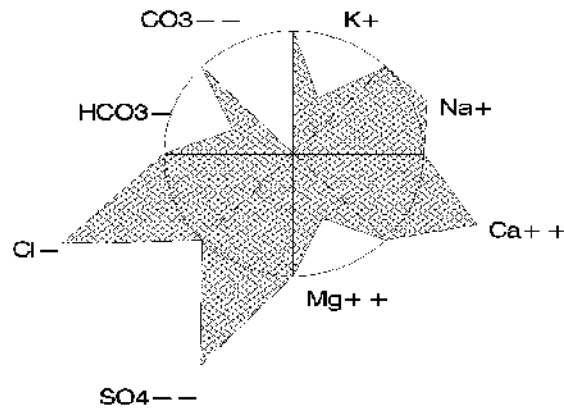

Persimmon Lake Highlands County

USGS Quadrangle: Lake June in Winter
 Section/Township/Range: 10-36S-29E
 Approx. Lake Center, Lat/Long: 272117/812422
 Surface Area: 30 acres
 Approx. Lake Elevation: 68 feet
 Average Depth: 6.6 feet
 Observed Maximum Depth: 11 feet
 (reference elevation 67 feet)
 Lake Type: outflow (type 2)
 Major Basin: Kissimmee Ridge
 Minor Basin: Lake Francis Outlet
 Lake Region: Lake Wales Ridge Transition
 Public Access: yes

Major Land Use/Land Cover (1990)
 within 500 meters of the lakeshore:
 - tree crops, typically citrus (43%)
 - low density residential (24%)
 - pine flatwoods (22%)

Total Number of Samples Collected: 11 Most Recent Sample Collected: July 1995

Parameter	Units (Detection Limit)	Average Value	District Percentile	Florida Percentile
Chlorophyll a	ug/l (1)	94.1	>95	95
Total Phosphorus	mg/l as P (0.01)	0.044	85	37
Total Nitrogen	mg/l as N (0.06)	2.99	95	91
Transparency (Secchi depth)	meters	0.32	<5	<5
Florida Trophic State Index		77	>95	93
Specific Conductance	S/cm at 25C (1)	339	91	72
pH	standard units (0.1)	7.9	78	67
Color	PtCo units (1)	24	60	19
Turbidity	NTU (1)	30.2	>95	90
Total Alkalinity	mg/l as CaCO3 (1)	34	64	52
Hardness	mg/l as CaCO3 (0.02)	94	89	
Total Suspended Solids	mg/l (0.05)	18.4	>95	
Ammonia	mg/l as N (0.03)	0.179	95	
Nitrate+Nitrite	mg/l as N (0.01)	0.262	88	
Total Kjeldahl Nitrogen	mg/l as N (0.06)	2.73	>95	
Orthophosphorus	mg/l as P (0.01)	0.036	91	
Chloride	mg/l (0.05)	35	92	
Sulfate	mg/l (0.05)	19	58	
Sodium	mg/l (0.06)	7.4	37	
Potassium	mg/l (0.07)	7.3	83	
Calcium	mg/l (0.04)	15.0	60	
Magnesium	mg/l (0.006)	13.7	95	
Iron	ug/l (0.03)	18	16	

Based upon the average FTSI of 77, water quality is considered poor. Persimmon Lake can be characterized as a moderately colored, hard water, hypereutrophic lake, with high concentrations of total phosphorus and high concentrations of total nitrogen. The chemical type of water (predominant ionic composition) is calcium sulfate.

Plots and Trends: No or insufficient data available for plotting or trend detection. Shown is a diagram of the relative ionic composition of the lake water.

MAJOR IONS (% meq/l)

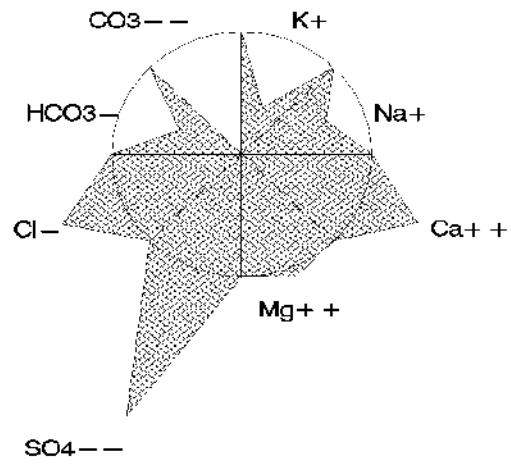

Persimmon Lake, Highlands County

Lake Placid Highlands County

USGS Quadrangle: Childs Major Land Use/Land Cover (1990)
 Section/Township/Range: 30-37S-30E within 500 meters of the lakeshore:
 Approx. Lake Center, Lat/Long: 271345/812145 - tree crops, typically citrus (33%)
 Surface Area: 3320 acres - stream and lake swamps (12%)
 Approx. Lake Elevation: 95 feet - low density residential (11%)
 Average Depth: 20.7 feet
 Observed Maximum Depth: 50 feet
 (reference elevation 92.94 feet)
 Lake Type: inflow and outflow (type 3)
 Major Basin: Kissimmee Ridge
 Minor Basin: Lake Francis Outlet
 Lake Region: Southern Lake Wales Ridge
 Public Access: yes

Total Number of Samples Collected: 5 Most Recent Sample Collected: April 1994

Parameter	Units (Detection Limit)	Average Value	District Percentile	Florida Percentile
Chlorophyll a	ug/l (1)	8.1	58	33
Total Phosphorus	mg/l as P (0.01)	0.014	50	7
Total Nitrogen	mg/l as N (0.06)	0.49	5	10
Transparency (Secchi depth)	meters	2.08	66	86
Florida Trophic State Index		37	47	12
Specific Conductance	S/cm at 25C (1)	106	14	25
pH	standard units (0.1)	6.8	25	25
Color	PtCo units (1)	5	9	5
Turbidity	NTU (1)	2.5	58	26
Total Alkalinity	mg/l as CaCO3 (1)	5	13	13
Hardness	mg/l as CaCO3 (0.02)	30	21	
Total Suspended Solids	mg/l (0.05)	2.7	61	
Ammonia	mg/l as N (0.03)	0.015	60	
Nitrate+Nitrite	mg/l as N (0.01)	0.015	44	
Total Kjeldahl Nitrogen	mg/l as N (0.06)	0.48	8	
Orthophosphorus	mg/l as P (0.01)	0.005	56	
Chloride	mg/l (0.05)	16	37	
Sulfate	mg/l (0.05)	5	20	
Sodium	mg/l (0.06)	7.5	39	
Potassium	mg/l (0.07)	4.3	59	
Calcium	mg/l (0.04)	4.7	13	
Magnesium	mg/l (0.006)	4.5	63	
Iron	ug/l (0.03)	31	41	

Based upon the average FTSI of 37, water quality is considered good. Lake Placid can be characterized as a clear (color<=10 color units), soft water, meso-eutrophic lake, with very low concentrations of total nitrogen. The chemical type of water (predominant ionic composition) is sodium chloride.

Plots and Trends: Similar to plots of lake elevation for other lakes in the Lake Wales Ridge region, Lake Placid surface elevations have generally increased during the 1990s, recovering from the drought years in the mid- to late 1980s in the Lake Wales Ridge region. Measures of water chemistry have generally been stable over the period of record, however, conductivity demonstrates an increasing trend over the past 30 years, probably reflective of land use changes. Conductivity remains quite low (14th percentile of 323 lakes sampled). Also shown is a diagram of the relative ionic composition of the lake water.

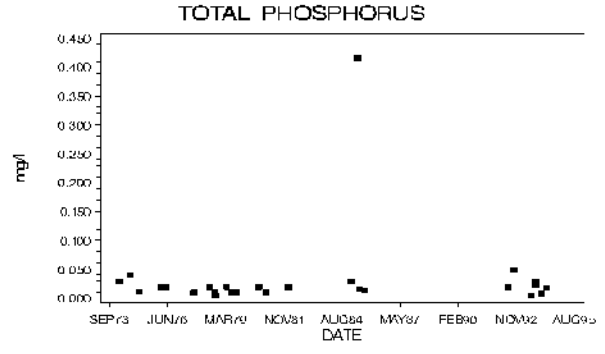
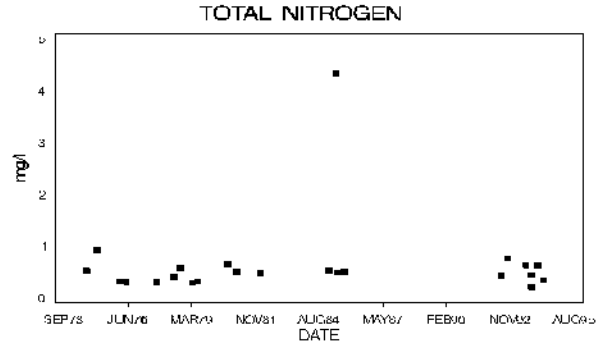
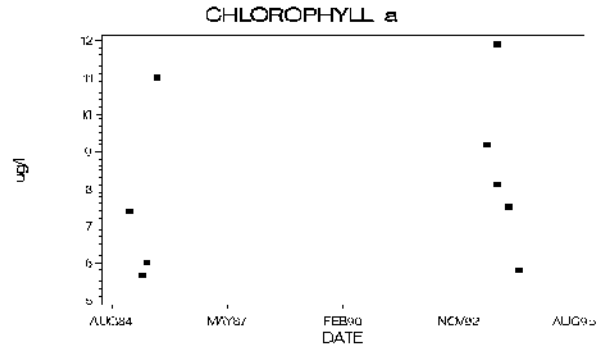
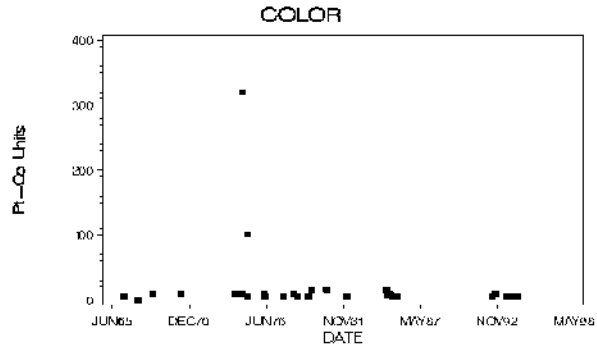
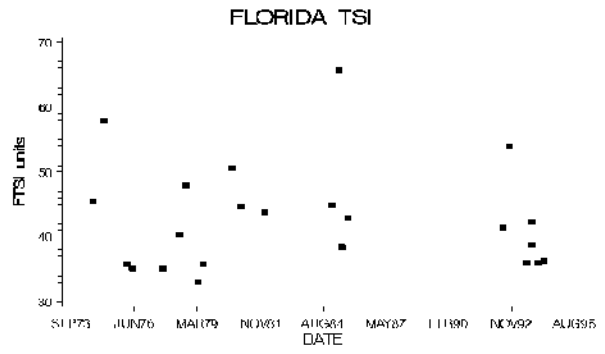
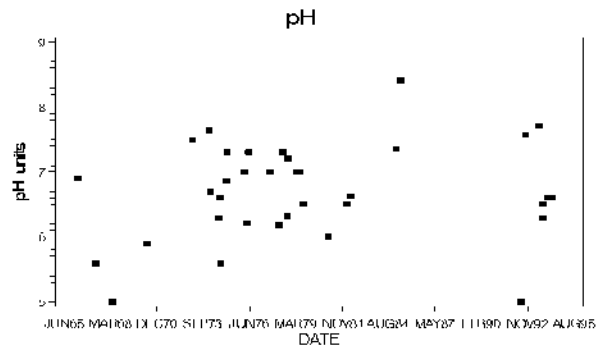
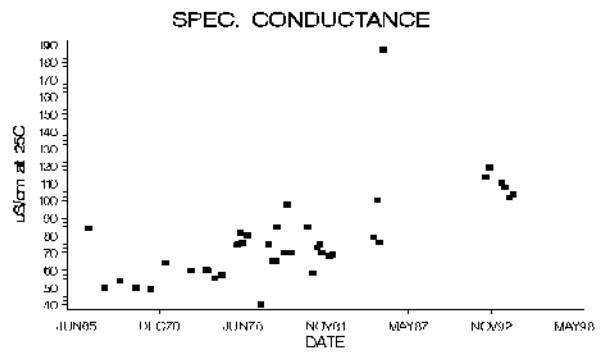
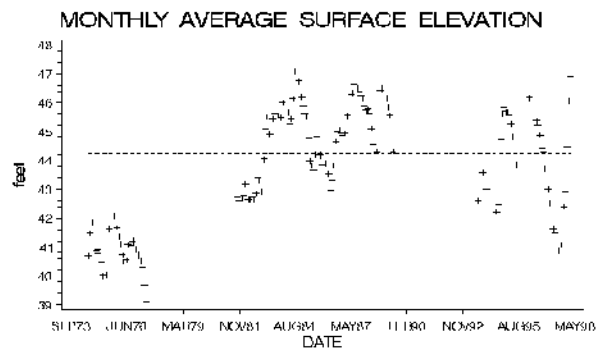

Lake Placid, Highlands County

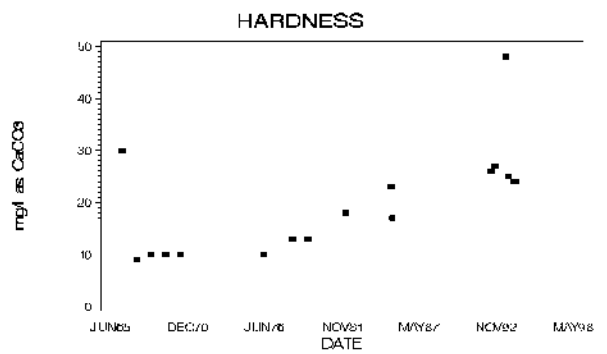
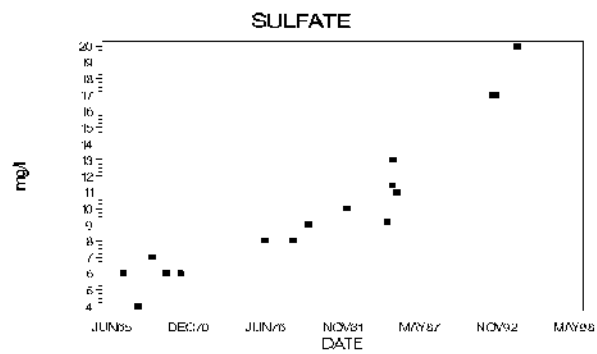
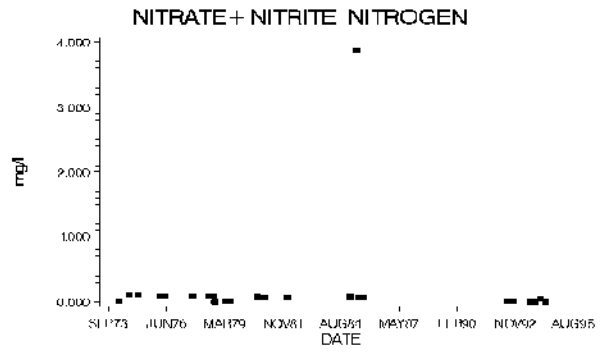
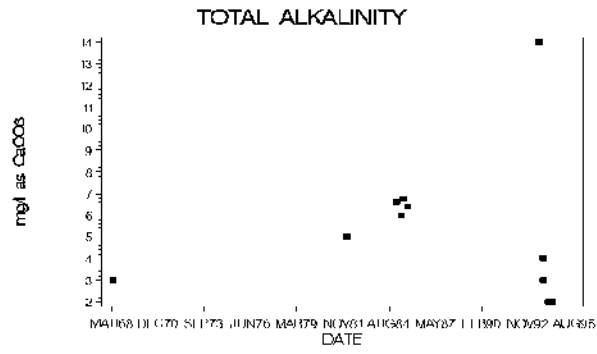
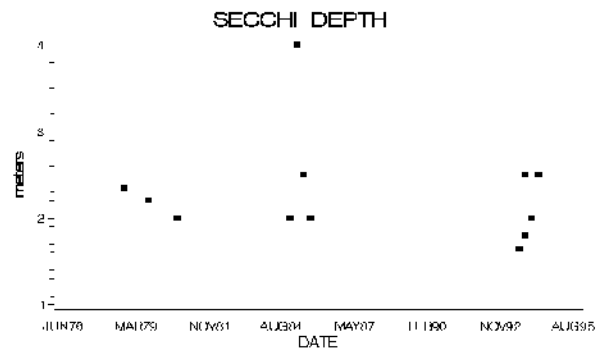
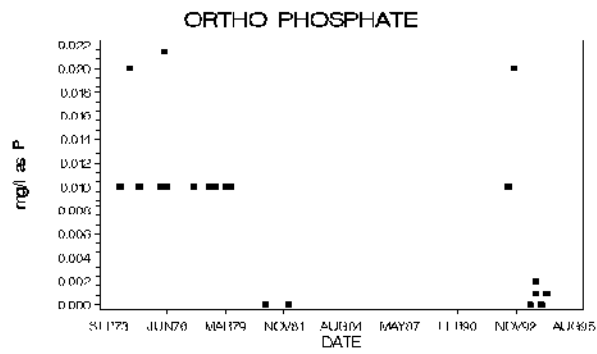

MAJOR IONS (% meq/l)

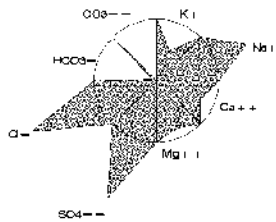

Lake Placid, Highlands County

Lake Pythias

Highlands County

USGS Quadrangle: Lake Arbuckle Major Land Use/Land Cover (1990)
 Section/Township/Range: 2-33S-28E within 500 meters of the lakeshore:
 Approx. Lake Center, Lat/Long: 273808/812951 - tree crops, typically citrus (43%)
 Surface Area: 318 acres - cropland and pastureland (36%)
 Approx. Lake Elevation: 101 feet - wet prairies (8%)
 Lake Type: inflow and outflow (type 3)
 Major Basin: Kissimmee Ridge
 Minor Basin: Grassy Creek
 Lake Region: Southern Lake Wales Ridge

Total Number of Samples Collected: 2 Most Recent Sample Collected: January 1995

Parameter	Units (Detection Limit)	Average Value	District Percentile	Florida Percentile
Chlorophyll a	ug/l (1)	4.1	37	17
Total Phosphorus	mg/l as P (0.01)	0.014	50	7
Total Nitrogen	mg/l as N (0.06)	0.56	7	13
Transparency (Secchi depth)	meters	2.00	64	85
Florida Trophic State Index		33	36	8
Specific Conductance	S/cm at 25C (1)	174	47	47
pH	standard units (0.1)	6.8	25	25
Color	PtCo units (1)	10	34	10
Turbidity	NTU (1)	2.4	56	25
Total Alkalinity	mg/l as CaCO3 (1)	10	27	25
Hardness	mg/l as CaCO3 (0.02)	48	50	
Total Suspended Solids	mg/l (0.05)	2.9	64	
Ammonia	mg/l as N (0.03)	0.015	60	
Nitrate+Nitrite	mg/l as N (0.01)	0.009	33	
Total Kjeldahl Nitrogen	mg/l as N (0.06)	0.56	12	
Orthophosphorus	mg/l as P (0.01)	0.014	76	
Chloride	mg/l (0.05)	20	56	
Sulfate	mg/l (0.05)	34	83	
Sodium	mg/l (0.06)	8.1	45	
Potassium	mg/l (0.07)	6.4	77	
Calcium	mg/l (0.04)	5.7	17	
Magnesium	mg/l (0.006)	8.2	84	
Iron	ug/l (0.03)	62	69	

Based upon the average FTSI of 33, water quality is considered good. Lake Pythias can be characterized as a clear (color<=10 color units), soft water, mesotrophic lake, with very low concentrations of total nitrogen. The chemical type of water (predominant ionic composition) is magnesium sulfate (1 sample) or sodium sulfate (1 sample).

Plots and Trends: No or insufficient data available for plotting or trend detection. Shown is a diagram of the relative ionic composition of the lake water.

MAJOR IONS (% meq/l)

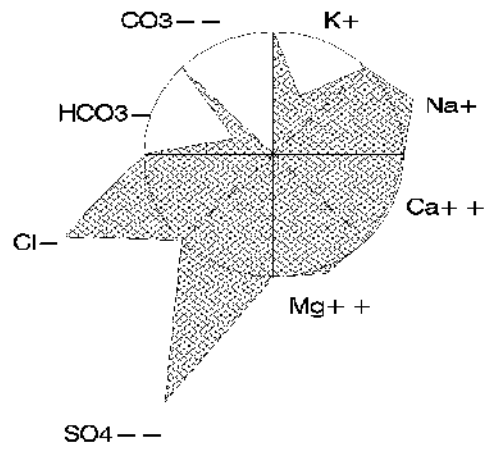

Red Beach Lake Highlands County

USGS Quadrangle: Sebring Major Land Use/Land Cover (1990)
 Section/Township/Range: 15-35S-29E within 500 meters of the lakeshore:
 Approx. Lake Center, Lat/Long: 272556/812414 - medium density residential (26%)
 Surface Area: 335 acres - stream and lake swamps (25%)
 Approx. Lake Elevation: 77 feet - tree crops, typically citrus (20%)
 Average Depth: 9.2 feet
 Observed Maximum Depth: 17 feet
 (reference elevation 75 feet)
 Lake Type: outflow (type 2)
 Major Basin: Kissimmee Ridge
 Minor Basin: Yellow Bluff Creek
 Lake Region: Lake Wales Ridge Transition
 Public Access: yes

Total Number of Samples Collected: 2 Most Recent Sample Collected: January 1995

Parameter	Units (Detection Limit)	Average Value	District Percentile	Florida Percentile
Chlorophyll a	ug/l (1)	6.9	52	30
Total Phosphorus	mg/l as P (0.01)	0.012	41	6
Total Nitrogen	mg/l as N (0.06)	0.71	18	21
Transparency (Secchi depth)	meters	0.93	30	61
Florida Trophic State Index		45	63	26
Specific Conductance	S/cm at 25C (1)	89	10	19
pH	standard units (0.1)	6.7	21	23
Color	PtCo units (1)	45	76	35
Turbidity	NTU (1)	5.3	75	52
Total Alkalinity	mg/l as CaCO3 (1)	22	45	41
Hardness	mg/l as CaCO3 (0.02)	17	7	
Total Suspended Solids	mg/l (0.05)	4.7	77	
Ammonia	mg/l as N (0.03)	0.015	60	
Nitrate+Nitrite	mg/l as N (0.01)	0.290	89	
Total Kjeldahl Nitrogen	mg/l as N (0.06)	0.42	<5	
Orthophosphorus	mg/l as P (0.01)	0.016	82	
Chloride	mg/l (0.05)	12	23	
Sulfate	mg/l (0.05)	12	41	
Sodium	mg/l (0.06)	6.5	27	
Potassium	mg/l (0.07)	2.3	37	
Calcium	mg/l (0.04)	1.9	<5	
Magnesium	mg/l (0.006)	3.0	45	
Iron	ug/l (0.03)	99	81	

Based upon the average FTSI of 45, water quality is considered good. Red Beach Lake can be characterized as a colored, soft water, meso-eutrophic lake, with low concentrations of total nitrogen. The chemical type of water (predominant ionic composition) is sodium bicarbonate (1 sample) or sodium chloride (1 sample).

Plots and Trends: Lake levels in the 1990s appear to be somewhat greater than those recorded during the 1980s. This is reflective of the increasing trend in rainfall from the period of relative drought in the mid- and late 1980s in the Lake Wales Ridge region. Also shown is a diagram of the relative ionic composition of the lake water.

MONTHLY AVERAGE SURFACE ELEVATION

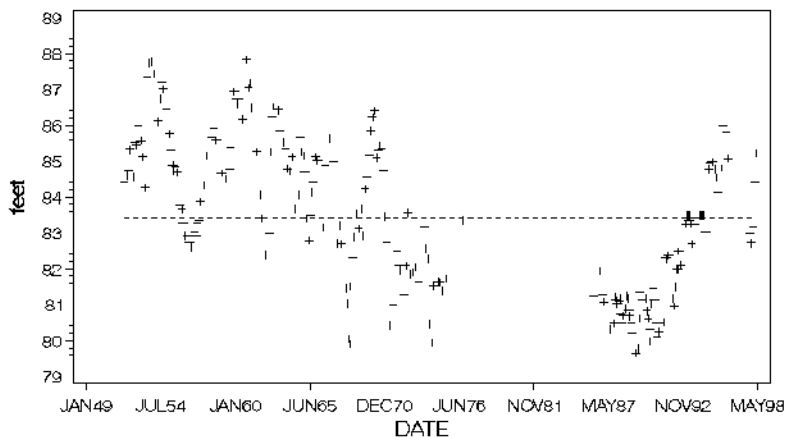

CHLOROPHYLL a

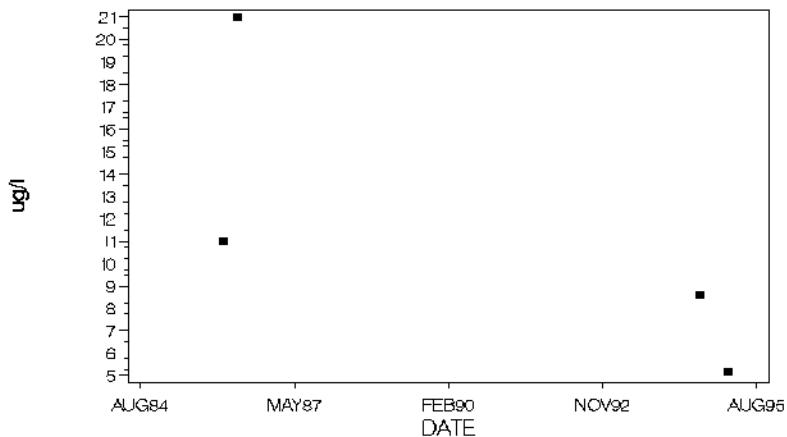

MAJOR IONS (% meq/l)

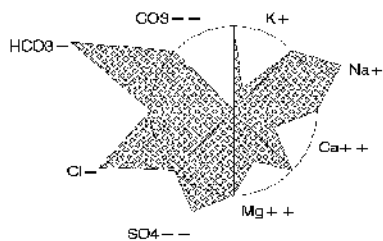

Red Beach Lake, Highlands County

Red Water Lake Highlands County

USGS Quadrangle: Lake June in Winter
 Section/Township/Range: 14-36S-29E
 Approx. Lake Center, Lat/Long: 272050/812343
 Surface Area: 66 acres
 Approx. Lake Elevation: 71 feet
 Average Depth: 8.2 feet
 Observed Maximum Depth: 16 feet
 (reference elevation not given)
 Lake Type: inflow and outflow (type 3)
 Major Basin: Kissimmee Ridge
 Minor Basin: Lake Francis Outlet
 Lake Region: Lake Wales Ridge Transition
 Public Access: yes

Major Land Use/Land Cover (1990)
 within 500 meters of the lakeshore:
 - medium density residential (36%)
 - tree crops, typically citrus (34%)
 - cropland and pastureland (13%)

Total Number of Samples Collected: 2 Most Recent Sample Collected: February 1995

Parameter	Units (Detection Limit)	Average Value	District Percentile	Florida Percentile
Chlorophyll a	ug/l (1)	10.8	67	40
Total Phosphorus	mg/l as P (0.01)	0.008	31	<5
Total Nitrogen	mg/l as N (0.06)	1.71	75	71
Transparency (Secchi depth)	meters	0.95	31	62
Florida Trophic State Index		47	69	30
Specific Conductance	S/cm at 25C (1)	215	65	54
pH	standard units (0.1)	7.1	38	35
Color	PtCo units (1)	8	24	8
Turbidity	NTU (1)	4.9	74	49
Total Alkalinity	mg/l as CaCO3 (1)	16	37	34
Hardness	mg/l as CaCO3 (0.02)	67	70	
Total Suspended Solids	mg/l (0.05)	4.0	73	
Ammonia	mg/l as N (0.03)	0.015	60	
Nitrate+Nitrite	mg/l as N (0.01)	0.611	92	
Total Kjeldahl Nitrogen	mg/l as N (0.06)	1.10	55	
Orthophosphorus	mg/l as P (0.01)	0.014	76	
Chloride	mg/l (0.05)	24	74	
Sulfate	mg/l (0.05)	42	89	
Sodium	mg/l (0.06)	8.8	50	
Potassium	mg/l (0.07)	7.3	83	
Calcium	mg/l (0.04)	11.9	47	
Magnesium	mg/l (0.006)	9.2	86	
Iron	ug/l (0.03)	9	<5	

Based upon the average FTSI of 47, water quality is considered good. Red Water Lake can be characterized as a clear (color<=10 color units), medium hard water, eutrophic lake, with low concentrations of total phosphorus. The chemical type of water (predominant ionic composition) is calcium sulfate.

Plots and Trends: No or insufficient data available for plotting or trend detection. Shown is a diagram of the relative ionic composition of the lake water.

MAJOR IONS (% meq/l)

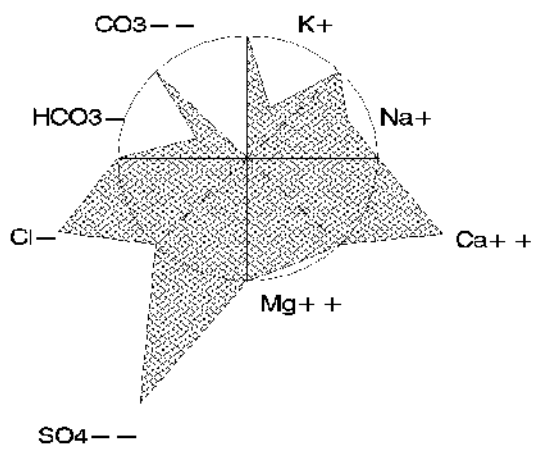

Red Water Lake, Highlands County

Lake Ruth

Highlands County

USGS Quadrangle: Sebring Major Land Use/Land Cover (1990)
 Section/Township/Range: 18-35S-29E within 500 meters of the lakeshore:
 Approx. Lake Center, Lat/Long: 272544/812731 - pine flatwoods (57%)
 Surface Area: 83 acres - open land (19%)
 Approx. Lake Elevation: 94 feet - cropland and pastureland (12%)
 Lake Type: outflow (type 2)
 Major Basin: Kissimmee Ridge
 Minor Basin: Lake Ruth Outlet
 Lake Region: Lake Wales Ridge Transition

Total Number of Samples Collected: 2 Most Recent Sample Collected: February 1995

Parameter	Units (Detection Limit)	Average Value	District Percentile	Florida Percentile
Chlorophyll a	ug/l (1)	3.9	35	16
Total Phosphorus	mg/l as P (0.01)	0.005	31	<5
Total Nitrogen	mg/l as N (0.06)	1.05	45	35
Transparency (Secchi depth)	meters	2.05	65	86
Florida Trophic State Index		29	26	<5
Specific Conductance	S/cm at 25C (1)	53	<5	6
pH	standard units (0.1)	4.4	<5	<5
Color	PtCo units (1)	35	70	27
Turbidity	NTU (1)	1.4	39	11
Total Alkalinity	mg/l as CaCO3 (1)	3	7	8
Hardness	mg/l as CaCO3 (0.02)	10	<5	
Total Suspended Solids	mg/l (0.05)	1.8	47	
Ammonia	mg/l as N (0.03)	0.015	60	
Nitrate+Nitrite	mg/l as N (0.01)	0.009	33	
Total Kjeldahl Nitrogen	mg/l as N (0.06)	1.05	52	
Orthophosphorus	mg/l as P (0.01)	0.010	59	
Chloride	mg/l (0.05)	8	9	
Sulfate	mg/l (0.05)	7	27	
Sodium	mg/l (0.06)	4.2	10	
Potassium	mg/l (0.07)	0.3	7	
Calcium	mg/l (0.04)	2.1	<5	
Magnesium	mg/l (0.006)	1.1	8	
Iron	ug/l (0.03)	56	65	

Based upon the average FTSI of 29, water quality is considered good. Lake Ruth can be characterized as a moderately colored, soft water, oligo-mesotrophic lake, with low concentrations of total phosphorus. The chemical type of water (predominant ionic composition) is sodium chloride.

Also of note:

- The measured pH was very low.

Plots and Trends: No or insufficient data available for plotting or trend detection. Shown is a diagram of the relative ionic composition of the lake water.

MAJOR IONS (% meq/l)

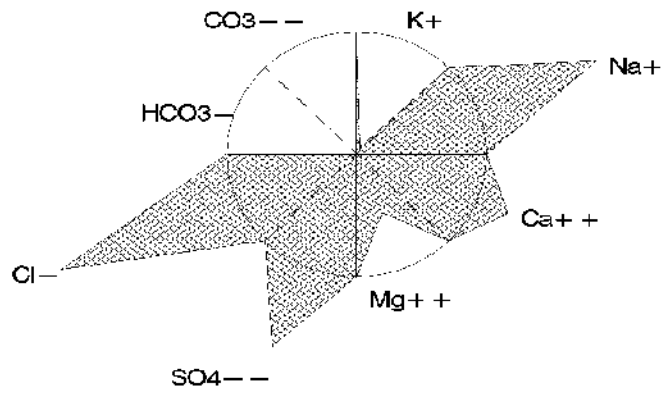

Lake Ruth, Highlands County

Saddlebags Lake Highlands County

USGS Quadrangle:	Lake Placid	Major Land Use/Land Cover (1990)
Section/Township/Range:	6-37S-30E	within 500 meters of the lakeshore:
Approx. Lake Center, Lat/Long:	271739/812117	- tree crops, typically citrus (36%)
Surface Area:	23 acres	- medium density residential (27%)
Approx. Lake Elevation:	84 feet	- commercial and services (21%)
Average Depth: 14.5 feet		
Observed Maximum Depth: 27 feet		
(reference elevation 80.2 feet)		
Lake Type: isolated (type 4)		
Major Basin: Kissimmee Ridge		
Minor Basin: Grassy Creek		
Lake Region: Southern Lake Wales Ridge		

Total Number of Samples Collected: 2 Most Recent Sample Collected: January 1996

Parameter	Units (Detection Limit)	Average Value	District Percentile	Florida Percentile
Chlorophyll a	ug/l (1)	1.5	5	5
Total Phosphorus	mg/l as P (0.01)	0.008	31	<5
Total Nitrogen	mg/l as N (0.06)	1.30	61	45
Transparency (Secchi depth)	meters	2.50	75	92
Florida Trophic State Index		19	5	<5
Specific Conductance	S/cm at 25C (1)	342	92	72
pH	standard units (0.1)	7.7	69	60
Color	PtCo units (1)	5	9	5
Turbidity	NTU (1)	1.1	32	7
Total Alkalinity	mg/l as CaCO3 (1)	27	54	46
Hardness	mg/l as CaCO3 (0.02)	112	93	
Total Suspended Solids	mg/l (0.05)	0.8	21	
Ammonia	mg/l as N (0.03)	0.057	79	
Nitrate+Nitrite	mg/l as N (0.01)	1.001	95	
Total Kjeldahl Nitrogen	mg/l as N (0.06)	0.31	<5	
Orthophosphorus	mg/l as P (0.01)	0.005	56	
Chloride	mg/l (0.05)	27	80	
Sulfate	mg/l (0.05)	88	>95	
Sodium	mg/l (0.06)	8.9	51	
Potassium	mg/l (0.07)	14.0	>95	
Calcium	mg/l (0.04)	23.5	84	
Magnesium	mg/l (0.006)	13.0	93	
Iron	ug/l (0.03)	17	13	

Based upon the average FTSI of 19, water quality is considered good. Saddlebags Lake can be characterized as a clear (color<=10 color units), medium hard water, oligotrophic lake, with low concentrations of total phosphorus and high nitrate concentrations. The chemical type of water (predominant ionic composition) is calcium sulfate.

Plots and Trends: No or insufficient data available for plotting or trend detection. Shown is a diagram of the relative ionic composition of the lake water.

MAJOR IONS (% meq/l)

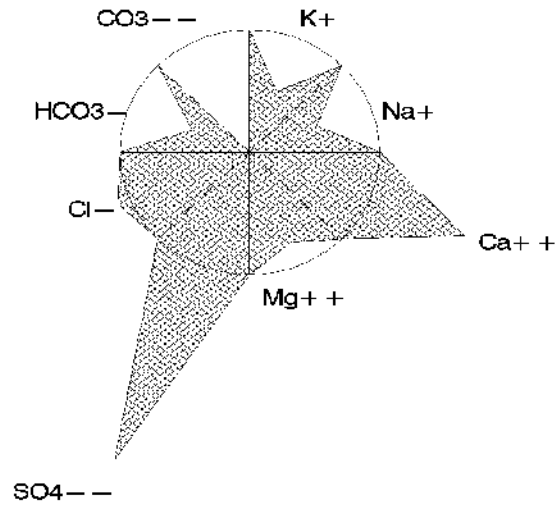

Saddlebags Lake, Highlands County

Lake Sebring Highlands County

USGS Quadrangle: Lake Arbuckle SW Major Land Use/Land Cover (1990)
 Section/Township/Range: 14-34S-28E within 500 meters of the lakeshore:
 Approx. Lake Center, Lat/Long: 273139/812902 - medium density residential (41%)
 Surface Area: 468 acres - open land (13%)
 Approx. Lake Elevation: 107 feet - tree crops, typically citrus (12%)
 Average Depth: 6.6 feet
 Observed Maximum Depth: 17 feet
 (reference elevation 106 feet)
 Lake Type: inflow and outflow (type 3)
 Major Basin: Kissimmee Ridge
 Minor Basin: Little Red Water Lk 01
 Lake Region: Lake Wales Ridge Transition
 Public Access: yes

Total Number of Samples Collected: 2 Most Recent Sample Collected: January 1995

Parameter	Units (Detection Limit)	Average Value	District Percentile	Florida Percentile
Chlorophyll a	ug/l (1)	9.9	63	37
Total Phosphorus	mg/l as P (0.01)	0.053	88	42
Total Nitrogen	mg/l as N (0.06)	1.13	51	38
Transparency (Secchi depth)	meters	0.48	7	17
Florida Trophic State Index		63	87	62
Specific Conductance	S/cm at 25C (1)	96	12	21
pH	standard units (0.1)	6.6	18	20
Color	PtCo units (1)	163	95	93
Turbidity	NTU (1)	7.7	83	62
Total Alkalinity	mg/l as CaCO3 (1)	4	10	10
Hardness	mg/l as CaCO3 (0.02)	16	6	
Total Suspended Solids	mg/l (0.05)	4.0	73	
Ammonia	mg/l as N (0.03)	0.015	60	
Nitrate+Nitrite	mg/l as N (0.01)	0.080	79	
Total Kjeldahl Nitrogen	mg/l as N (0.06)	1.05	52	
Orthophosphorus	mg/l as P (0.01)	0.037	92	
Chloride	mg/l (0.05)	15	34	
Sulfate	mg/l (0.05)	12	41	
Sodium	mg/l (0.06)	9.0	52	
Potassium	mg/l (0.07)	1.8	30	
Calcium	mg/l (0.04)	3.6	7	
Magnesium	mg/l (0.006)	1.6	18	
Iron	ug/l (0.03)	166	90	

Based upon the average FTSI of 63, water quality is considered fair. Lake Sebring can be characterized as a highly colored, soft water, eutrophic lake, with high concentrations of total phosphorus. The chemical type of water (predominant ionic composition) is sodium chloride.

Plots and Trends: Lake surface elevations have been relatively stable over the relatively short period of record. The two more recently collected samples had lower concentrations of total phosphorus than samples collected in the 1970s and 1980s, however, the time interval between samples is sporadic, and no trend is evident. Also shown is a diagram of the relative ionic composition of the lake water.

MONTHLY AVERAGE SURFACE ELEVATION

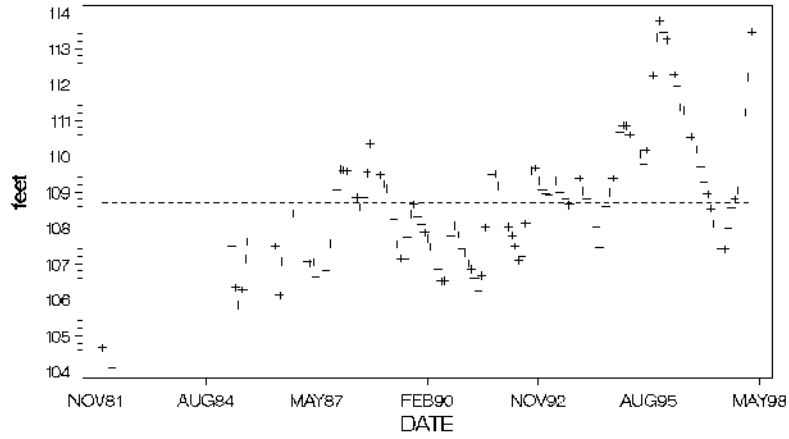

TOTAL PHOSPHORUS

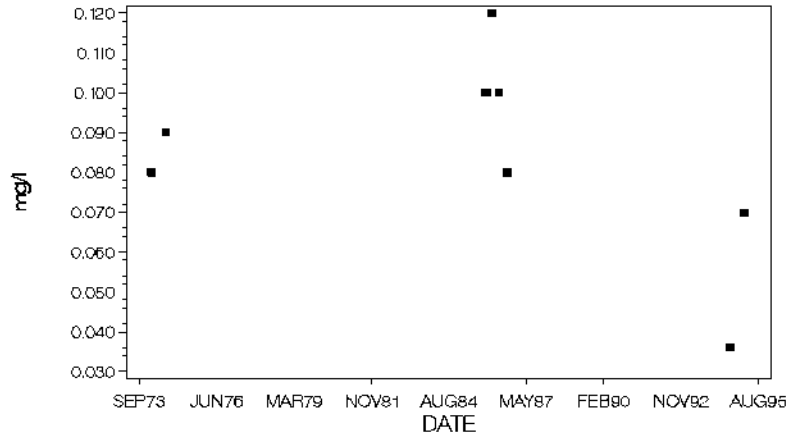

MAJOR IONS (% meq/l)

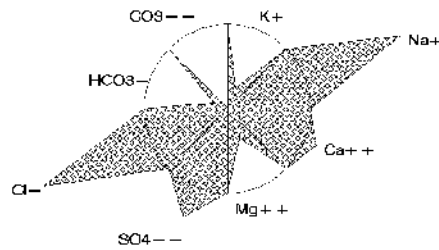

Silver Lake

Highlands County

USGS Quadrangle: Avon Park Major Land Use/Land Cover (1990)
 Section/Township/Range: 33-33S-28E within 500 meters of the lakeshore:
 Approx. Lake Center, Lat/Long: 273358/813123 - shrub and brushland range (41%)
 Surface Area: 20 acres - high density residential (19%)
 Approx. Lake Elevation: 138 feet - other open lands - rural (18%)
 Lake Type: outflow (type 2)
 Major Basin: Kissimmee Ridge
 Minor Basin: Carter Creek
 Lake Region: Southern Lake Wales Ridge

Total Number of Samples Collected: 2 Most Recent Sample Collected: February 1995

Parameter	Units (Detection Limit)	Average Value	District Percentile	Florida Percentile
Chlorophyll a	ug/l (1)	2.3	15	10
Total Phosphorus	mg/l as P (0.01)	0.005	31	<5
Total Nitrogen	mg/l as N (0.06)	2.92	94	91
Transparency (Secchi depth)	meters	4.35	95	>95
Florida Trophic State Index		19	6	<5
Specific Conductance	S/cm at 25C (1)	74	5	13
pH	standard units (0.1)	4.5	<5	<5
Color	PtCo units (1)	5	9	5
Turbidity	NTU (1)	0.5	28	<5
Total Alkalinity	mg/l as CaCO3 (1)	1	<5	<5
Hardness	mg/l as CaCO3 (0.02)	13	<5	
Total Suspended Solids	mg/l (0.05)	1.0	28	
Ammonia	mg/l as N (0.03)	0.015	60	
Nitrate+Nitrite	mg/l as N (0.01)	0.010	34	
Total Kjeldahl Nitrogen	mg/l as N (0.06)	2.91	>95	
Orthophosphorus	mg/l as P (0.01)	0.010	59	
Chloride	mg/l (0.05)	7	7	
Sulfate	mg/l (0.05)	16	52	
Sodium	mg/l (0.06)	3.8	8	
Potassium	mg/l (0.07)	3.8	52	
Calcium	mg/l (0.04)	2.2	<5	
Magnesium	mg/l (0.006)	1.7	20	
Iron	ug/l (0.03)	16	12	

Based upon the average FTSI of 19, water quality is considered good. Silver Lake can be characterized as a clear (color<=10 color units), soft water, oligo-mesotrophic lake, with low concentrations of total phosphorus and high concentrations of total nitrogen. The chemical type of water (predominant ionic composition) is sodium sulfate.

Also of note:

- The measured pH was very low.

Plots and Trends: No or insufficient data available for plotting or trend detection. Shown is a diagram of the relative ionic composition of the lake water.

MAJOR IONS (% meq/l)

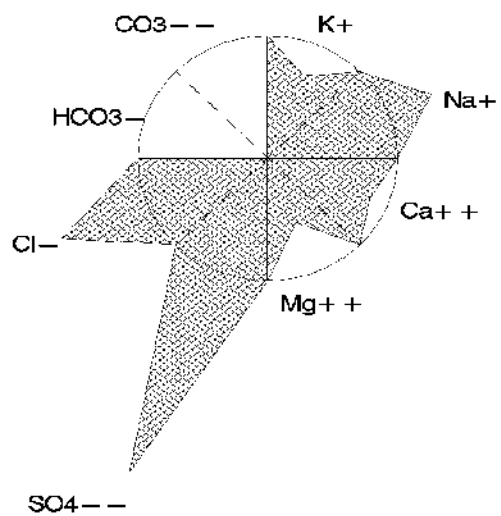

Lake Simmons Highlands County

USGS Quadrangle: Lake June in Winter
 Section/Township/Range: 24-36S-29E
 Approx. Lake Center, Lat/Long: 272017/812233
 Surface Area: 22 acres
 Approx. Lake Elevation: 72 feet
 Lake Type: isolated (type 4)
 Major Basin: Kissimmee Ridge
 Minor Basin: Grassy Creek
 Lake Region: Southern Lake Wales Ridge

Major Land Use/Land Cover (1990)
 within 500 meters of the lakeshore:
 - tree crops, typically citrus (100%)
 - freshwater marshes (1%)
 - (-%)

Total Number of Samples Collected: 2 Most Recent Sample Collected: February 1995

Parameter	Units (Detection Limit)	Average Value	District Percentile	Florida Percentile
Chlorophyll a	ug/l (1)	1.2	<5	<5
Total Phosphorus	mg/l as P (0.01)	0.005	31	<5
Total Nitrogen	mg/l as N (0.06)	7.12	>95	>95
Transparency (Secchi depth)	meters	6.25	>95	>95
Florida Trophic State Index		13	<5	<5
Specific Conductance	S/cm at 25C (1)	431	>95	78
pH	standard units (0.1)	7.9	78	67
Color	PtCo units (1)	5	9	5
Turbidity	NTU (1)	0.5	28	<5
Total Alkalinity	mg/l as CaCO3 (1)	46	77	60
Hardness	mg/l as CaCO3 (0.02)	163	>95	
Total Suspended Solids	mg/l (0.05)	0.4	8	
Ammonia	mg/l as N (0.03)	0.015	60	
Nitrate+Nitrite	mg/l as N (0.01)	7.025	>95	
Total Kjeldahl Nitrogen	mg/l as N (0.06)	0.11	<5	
Orthophosphorus	mg/l as P (0.01)	0.005	56	
Chloride	mg/l (0.05)	38	95	
Sulfate	mg/l (0.05)	77	>95	
Sodium	mg/l (0.06)	9.3	55	
Potassium	mg/l (0.07)	14.0	>95	
Calcium	mg/l (0.04)	29.5	92	
Magnesium	mg/l (0.006)	21.5	>95	
Iron	ug/l (0.03)	18	15	

Based upon the average FTSI of 13, water quality is considered good. Lake Simmons can be characterized as a clear (color<=10 color units), hard water, oligotrophic lake, with low concentrations of total phosphorus and high concentrations of total nitrogen, very high nitrate concentrations. The chemical type of water (predominant ionic composition) is calcium sulfate.

Plots and Trends: No or insufficient data available for plotting or trend detection. Shown is a diagram of the relative ionic composition of the lake water.

MAJOR IONS (% meq/l)

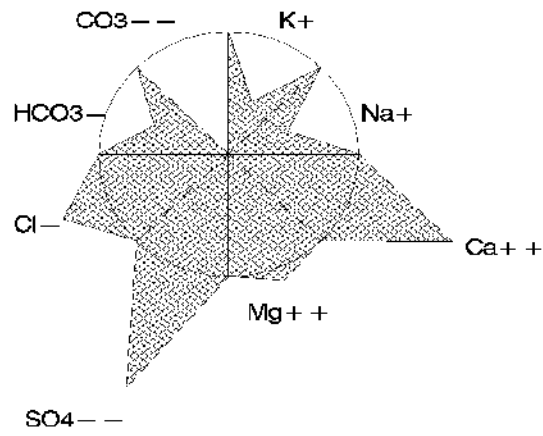

Lake Sirena Highlands County

USGS Quadrangle: Lake Placid
 Section/Township/Range: 1-37S-29E
 Approx. Lake Center, Lat/Long: 271705/812210
 Surface Area: 153 acres
 Approx. Lake Elevation: 87 feet
 Average Depth: 23.3 feet
 Observed Maximum Depth: 58 feet
 (reference elevation 82.5 feet)
 Lake Type: inflow and outflow (type 3)
 Major Basin: Kissimmee Ridge
 Minor Basin: Grassy Creek
 Lake Region: Southern Lake Wales Ridge

Major Land Use/Land Cover (1990)
 within 500 meters of the lakeshore:
 - tree crops, typically citrus (49%)
 - medium density residential (33%)
 - low density residential (6%)

Total Number of Samples Collected: 2 Most Recent Sample Collected: January 1995

Parameter	Units (Detection Limit)	Average Value	District Percentile	Florida Percentile
Chlorophyll a	ug/l (1)	2.0	13	8
Total Phosphorus	mg/l as P (0.01)	0.005	31	<5
Total Nitrogen	mg/l as N (0.06)	0.90	32	30
Transparency (Secchi depth)	meters	4.40	95	>95
Florida Trophic State Index		19	<5	<5
Specific Conductance	S/cm at 25C (1)	171	46	46
pH	standard units (0.1)	7.3	50	45
Color	PtCo units (1)	5	9	5
Turbidity	NTU (1)	0.5	28	<5
Total Alkalinity	mg/l as CaCO3 (1)	22	45	41
Hardness	mg/l as CaCO3 (0.02)	46	48	
Total Suspended Solids	mg/l (0.05)	0.6	15	
Ammonia	mg/l as N (0.03)	0.026	60	
Nitrate+Nitrite	mg/l as N (0.01)	0.084	79	
Total Kjeldahl Nitrogen	mg/l as N (0.06)	0.82	33	
Orthophosphorus	mg/l as P (0.01)	0.010	59	
Chloride	mg/l (0.05)	18	46	
Sulfate	mg/l (0.05)	31	79	
Sodium	mg/l (0.06)	7.5	39	
Potassium	mg/l (0.07)	5.7	71	
Calcium	mg/l (0.04)	9.2	35	
Magnesium	mg/l (0.006)	5.5	73	
Iron	ug/l (0.03)	5	<5	

Based upon the average FTSI of 19, water quality is considered good. Lake Sirena can be characterized as a clear (color<=10 color units), soft water, oligotrophic lake, with low concentrations of total phosphorus. The chemical type of water (predominant ionic composition) is calcium sulfate.

Plots and Trends: Shown are plots of lake surface elevation, total alkalinity, and hardness. Also shown is a diagram of the relative ionic composition of the lake water.

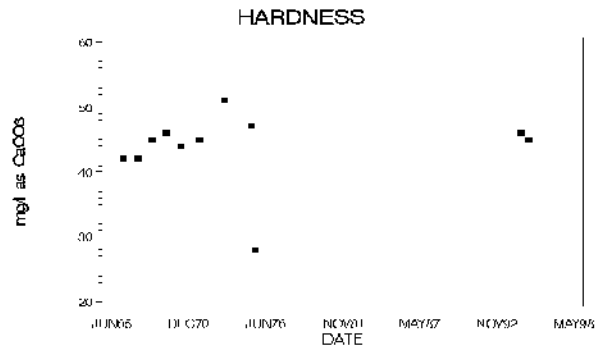
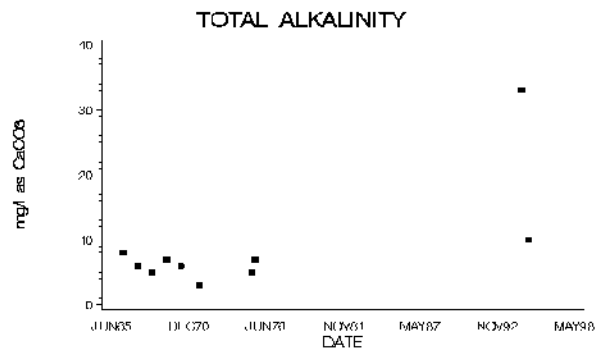
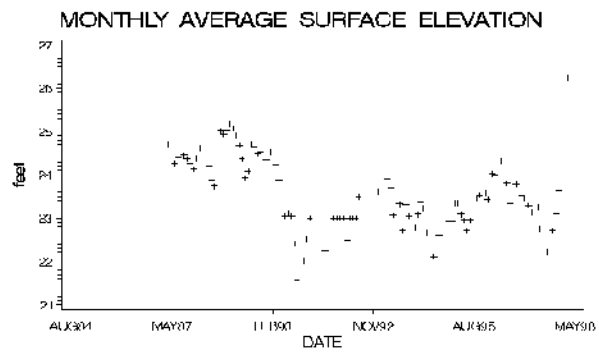

MAJOR IONS (% meq/l)

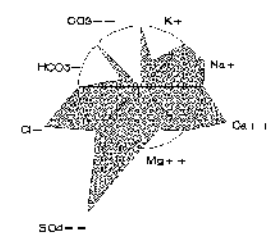

Stormwater Pond Highlands County

USGS Quadrangle: Venus NW Major Land Use/Land Cover (1990)
 Section/Township/Range: 23-37S-29E within 500 meters of the lakeshore:
 Approx. Lake Center, Lat/Long: 271430/812355 - low density residential (41%)
 Surface Area: 4 acres - open land (28%)
 Approx. Lake Elevation: 114 feet - shrub and brushland range (18%)
 Lake Type: outflow (type 2)
 Major Basin: Kissimmee Ridge
 Minor Basin: Lake Francis Outlet
 Lake Region: Lake Wales Ridge Transition

Total Number of Samples Collected: 2 Most Recent Sample Collected: January 1996

Parameter	Units (Detection Limit)	Average Value	District Percentile	Florida Percentile
Chlorophyll a	ug/l (1)	2.7	21	11
Total Phosphorus	mg/l as P (0.01)	0.013	46	7
Total Nitrogen	mg/l as N (0.06)	0.58	8	14
Transparency (Secchi depth)	meters	0.85	26	55
Florida Trophic State Index		38	48	13
Specific Conductance	S/cm at 25C (1)	68	<5	11
pH	standard units (0.1)	6.4	12	15
Color	PtCo units (1)	163	95	93
Turbidity	NTU (1)	3.6	68	38
Total Alkalinity	mg/l as CaCO3 (1)	14	33	32
Hardness	mg/l as CaCO3 (0.02)	20	9	
Total Suspended Solids	mg/l (0.05)	1.3	35	
Ammonia	mg/l as N (0.03)	0.024	60	
Nitrate+Nitrite	mg/l as N (0.01)	0.035	62	
Total Kjeldahl Nitrogen	mg/l as N (0.06)	0.55	11	
Orthophosphorus	mg/l as P (0.01)	0.005	56	
Chloride	mg/l (0.05)	11	19	
Sulfate	mg/l (0.05)	4	17	
Sodium	mg/l (0.06)	5.9	21	
Potassium	mg/l (0.07)	0.5	11	
Calcium	mg/l (0.04)	5.9	19	
Magnesium	mg/l (0.006)	1.4	15	
Iron	ug/l (0.03)	202	92	

Based upon the average FTSI of 38, water quality is considered good. Stormwater Pond can be characterized as a highly colored, soft water, oligo-mesotrophic lake, with very low concentrations of total nitrogen. The chemical type of water (predominant ionic composition) is calcium chloride.

Also of note:

- Melaleuca was observed on the lake shore.

Plots and Trends: No or insufficient data available for plotting or trend detection. Shown is a diagram of the relative ionic composition of the lake water.

MAJOR IONS (% meq/l)

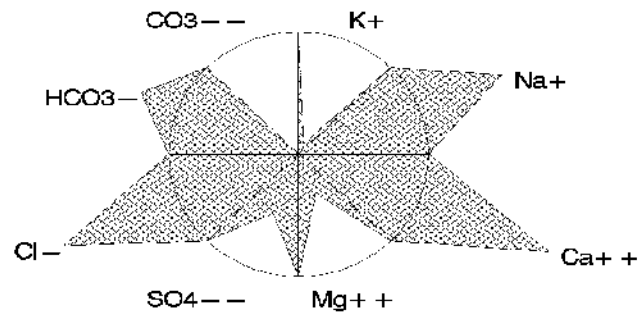

Stormwater Pond, Highlands County

Lake Tulane Highlands County

USGS Quadrangle: Avon Park Major Land Use/Land Cover (1990)
 Section/Township/Range: 27-33S-28E within 500 meters of the lakeshore:
 Approx. Lake Center, Lat/Long: 273509/813015 - medium density residential (73%)
 Surface Area: 89 acres - tree crops, typically citrus (7%)
 Approx. Lake Elevation: 120 feet - commercial and services (6%)
 Average Depth: 34.3 feet
 Observed Maximum Depth: 70 feet
 (reference elevation 109.9 feet)
 Lake Type: isolated (type 4)
 Major Basin: Kissimmee Ridge
 Minor Basin: Carter Creek
 Lake Region: Southern Lake Wales Ridge
 Public Access: yes

Total Number of Samples Collected: 10 Most Recent Sample Collected: April 1994

Parameter	Units (Detection Limit)	Average Value	District Percentile	Florida Percentile
Chlorophyll a	ug/l (1)	2.6	19	11
Total Phosphorus	mg/l as P (0.01)	0.008	31	<5
Total Nitrogen	mg/l as N (0.06)	0.87	30	29
Transparency (Secchi depth)	meters	5.57	>95	>95
Florida Trophic State Index		20	7	<5
Specific Conductance	S/cm at 25C (1)	139	31	39
pH	standard units (0.1)	7.2	43	40
Color	PtCo units (1)	5	9	5
Turbidity	NTU (1)	0.5	28	<5
Total Alkalinity	mg/l as CaCO3 (1)	20	42	39
Hardness	mg/l as CaCO3 (0.02)	30	21	
Total Suspended Solids	mg/l (0.05)	0.9	24	
Ammonia	mg/l as N (0.03)	0.042	70	
Nitrate+Nitrite	mg/l as N (0.01)	0.440	91	
Total Kjeldahl Nitrogen	mg/l as N (0.06)	0.42	<5	
Orthophosphorus	mg/l as P (0.01)	0.005	56	
Chloride	mg/l (0.05)	11	19	
Sulfate	mg/l (0.05)	5	20	
Sodium	mg/l (0.06)	3.3	<5	
Potassium	mg/l (0.07)	2.4	39	
Calcium	mg/l (0.04)	7.3	26	
Magnesium	mg/l (0.006)	3.0	45	
Iron	ug/l (0.03)	5	<5	

Based upon the average FTSI of 20, water quality is considered good. Lake Tulane can be characterized as a clear (color<=10 color units), soft water, oligotrophic lake, with low concentrations of total phosphorus. The chemical type of water (predominant ionic composition) is calcium sulfate.

Plots and Trends: No or insufficient data available for plotting or trend detection. Shown is a diagram of the relative ionic composition of the lake water.

MAJOR IONS (% meq/l)

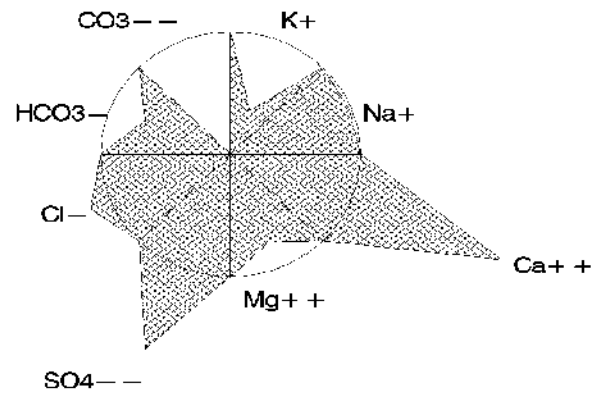

Lake Tulane, Highlands County

Unnamed B Lake Highlands County

USGS Quadrangle:	Lake Placid	Major Land Use/Land Cover (1990)
Section/Township/Range:	17-37S-30E	within 500 meters of the lakeshore:
Approx. Lake Center, Lat/Long:	271506/812030	- tree crops, typically citrus (58%)
Surface Area:	8 acres	- medium density residential (11%)
Approx. Lake Elevation:	89 feet	- hardwood - conifer mixed (8%)
Lake Type:	outflow (type 2)	
Major Basin:	Kissimmee Ridge	
Minor Basin:	Grassy Creek	
Lake Region:	Southern Lake Wales Ridge	

Total Number of Samples Collected: 3 Most Recent Sample Collected: January 1996

Parameter	Units (Detection Limit)	Average Value	District Percentile	Florida Percentile
Chlorophyll a	ug/l (1)	3.3	28	14
Total Phosphorus	mg/l as P (0.01)	0.008	31	<5
Total Nitrogen	mg/l as N (0.06)	1.08	47	36
Transparency (Secchi depth)	meters	2.60	77	93
Florida Trophic State Index		28	22	<5
Specific Conductance	S/cm at 25C (1)	179	49	48
pH	standard units (0.1)	7.3	50	45
Color	PtCo units (1)	5	9	5
Turbidity	NTU (1)	0.7	28	<5
Total Alkalinity	mg/l as CaCO3 (1)	15	36	33
Hardness	mg/l as CaCO3 (0.02)	50	53	
Total Suspended Solids	mg/l (0.05)	2.9	64	
Ammonia	mg/l as N (0.03)	0.026	60	
Nitrate+Nitrite	mg/l as N (0.01)	0.665	93	
Total Kjeldahl Nitrogen	mg/l as N (0.06)	0.42	<5	
Orthophosphorus	mg/l as P (0.01)	0.005	56	
Chloride	mg/l (0.05)	17	41	
Sulfate	mg/l (0.05)	21	63	
Sodium	mg/l (0.06)	7.5	39	
Potassium	mg/l (0.07)	6.3	76	
Calcium	mg/l (0.04)	11.7	46	
Magnesium	mg/l (0.006)	4.9	68	
Iron	ug/l (0.03)	33	43	

Based upon the average FTSI of 28, water quality is considered good. Unnamed B Lake can be characterized as a clear (color<=10 color units), soft water, oligo-mesotrophic lake, with low concentrations of total phosphorus. The chemical type of water (predominant ionic composition) is calcium sulfate.

Plots and Trends: No or insufficient data available for plotting or trend detection. Shown is a diagram of the relative ionic composition of the lake water.

MAJOR IONS (% meq/l)

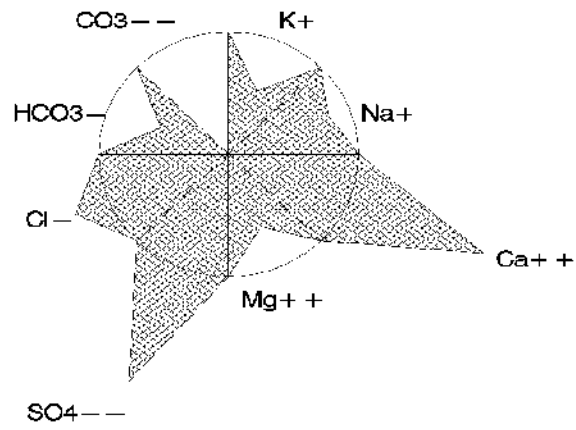

Unnamed "B" Lake, Highlands County

Unnamed E Lake

Highlands County

USGS Quadrangle: Lake June in Winter
 Section/Township/Range: 11-36S-29E
 Approx. Lake Center, Lat/Long: 272157/812338
 Surface Area: 14 acres
 Approx. Lake Elevation: 66 feet
 Lake Type: isolated (type 4)
 Major Basin: Kissimmee Ridge
 Minor Basin: Lake Francis Outlet
 Lake Region: Southern Lake Wales Ridge

Major Land Use/Land Cover (1990)
 within 500 meters of the lakeshore:
 - tree crops, typically citrus (78%)
 - pine flatwoods (7%)
 - transportation (6%)

Total Number of Samples Collected: 1 Most Recent Sample Collected: April 1993

Parameter	Units (Detection Limit)	Average Value	District Percentile	Florida Percentile
Chlorophyll a	ug/l (1)	4.3	39	17
Total Phosphorus	mg/l as P (0.01)	0.018	61	9
Total Nitrogen	mg/l as N (0.06)	1.73	76	72
Transparency (Secchi depth)	meters	-	-	-
Florida Trophic State Index		38	49	13
Specific Conductance	S/cm at 25C (1)	261	81	62
pH	standard units (0.1)	6.9	29	28
Color	PtCo units (1)	5	9	5
Turbidity	NTU (1)	1.2	34	8
Total Alkalinity	mg/l as CaCO3 (1)	13	32	31
Hardness	mg/l as CaCO3 (0.02)	78	78	
Total Suspended Solids	mg/l (0.05)	0.9	24	
Ammonia	mg/l as N (0.03)	0.210	>95	
Nitrate+Nitrite	mg/l as N (0.01)	0.523	91	
Total Kjeldahl Nitrogen	mg/l as N (0.06)	1.21	63	
Orthophosphorus	mg/l as P (0.01)	0.005	56	
Chloride	mg/l (0.05)	26	78	
Sulfate	mg/l (0.05)	0	<5	
Sodium	mg/l (0.06)	8.1	45	
Potassium	mg/l (0.07)	7.9	86	
Calcium	mg/l (0.04)	12.0	48	
Magnesium	mg/l (0.006)	11.0	90	
Iron	ug/l (0.03)	0	<5	

Based upon the average FTSI of 38, water quality is considered good. Unnamed E Lake can be characterized as a clear (color<=10 color units), medium hard water, mesotrophic lake.

Plots and Trends: No plots are shown for Unnamed E Lake.

Lake Schumacher Highlands County

USGS Quadrangle:	Avon Park	Major Land Use/Land Cover (1990)
Section/Township/Range:	22-34S-28E	within 500 meters of the lakeshore:
Approx. Lake Center, Lat/Long:	273037/813047	- open land (38%)
Surface Area:	7 acres	- high density residential (18%)
Approx. Lake Elevation:	165 feet	- specialty farms inc. horse, dairy, kennels (17%)
Lake Type:	isolated (type 4)	
Major Basin:	Peace River	
Minor Basin:	Little Charlie Bowlegs	
Lake Region:	Lake Wales Ridge Transition	

Total Number of Samples Collected: 2 Most Recent Sample Collected: January 1996

Parameter	Units (Detection Limit)	Average Value	District Percentile	Florida Percentile
Chlorophyll a	ug/l (1)	1.0	<5	<5
Total Phosphorus	mg/l as P (0.01)	0.005	31	<5
Total Nitrogen	mg/l as N (0.06)	1.05	45	35
Transparency (Secchi depth)	meters	1.70	56	80
Florida Trophic State Index		21	7	<5
Specific Conductance	S/cm at 25C (1)	459	>95	80
pH	standard units (0.1)	4.8	<5	<5
Color	PtCo units (1)	8	24	8
Turbidity	NTU (1)	0.5	28	<5
Total Alkalinity	mg/l as CaCO3 (1)	2	<5	5
Hardness	mg/l as CaCO3 (0.02)	5	<5	
Total Suspended Solids	mg/l (0.05)	0.2	<5	
Ammonia	mg/l as N (0.03)	0.015	60	
Nitrate+Nitrite	mg/l as N (0.01)	0.005	33	
Total Kjeldahl Nitrogen	mg/l as N (0.06)	1.04	51	
Orthophosphorus	mg/l as P (0.01)	0.005	56	
Chloride	mg/l (0.05)	7	7	
Sulfate	mg/l (0.05)	6	23	
Sodium	mg/l (0.06)	4.4	11	
Potassium	mg/l (0.07)	1.4	24	
Calcium	mg/l (0.04)	1.0	<5	
Magnesium	mg/l (0.006)	0.7	<5	
Iron	ug/l (0.03)	51	61	

Based upon the average FTSI of 21, water quality is considered good. Lake Schumacher can be characterized as a clear (color<=10 color units), soft water, oligotrophic lake, with low concentrations of total phosphorus. The chemical type of water (predominant ionic composition) is sodium chloride.

Also of note:

- measured pH was very low.

Plots and Trends: No or insufficient data available for plotting or trend detection. Shown is a diagram of the relative ionic composition of the lake water.

MAJOR IONS (% meq/l)

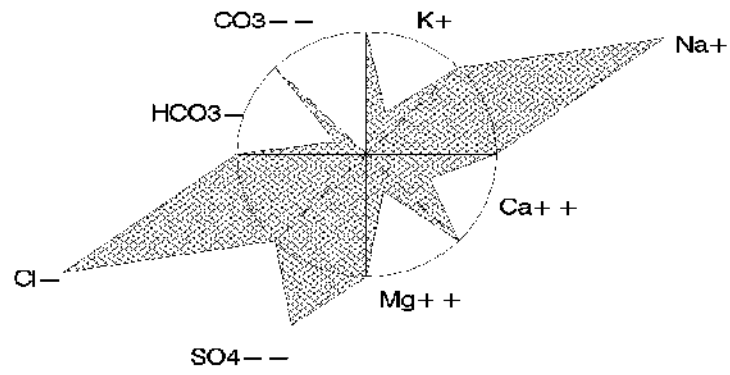

Lake Verona Highlands County

USGS Quadrangle: Lake Arbuckle SW Major Land Use/Land Cover (1990)
 Section/Township/Range: 23-33S-28E within 500 meters of the lakeshore:
 Approx. Lake Center, Lat/Long: 273551/812950 - medium density residential (65%)
 Surface Area: 35 acres - commercial and services (16%)
 Approx. Lake Elevation: 119 feet - tree crops, typically citrus (14%)
 Average Depth: 24.3 feet
 Observed Maximum Depth: 65 feet
 (reference elevation 109.8 feet)
 Lake Type: isolated (type 4)
 Major Basin: Kissimmee Ridge
 Minor Basin: Carter Creek
 Lake Region: Southern Lake Wales Ridge
 Public Access: yes

Total Number of Samples Collected: 10 Most Recent Sample Collected: April 1994

Parameter	Units (Detection Limit)	Average Value	District Percentile	Florida Percentile
Chlorophyll a	ug/l (1)	7.7	56	32
Total Phosphorus	mg/l as P (0.01)	0.008	31	<5
Total Nitrogen	mg/l as N (0.06)	0.62	12	16
Transparency (Secchi depth)	meters	3.69	91	>95
Florida Trophic State Index		29	25	<5
Specific Conductance	S/cm at 25C (1)	108	15	26
pH	standard units (0.1)	7.5	61	53
Color	PtCo units (1)	5	9	5
Turbidity	NTU (1)	1.8	47	17
Total Alkalinity	mg/l as CaCO3 (1)	23	46	42
Hardness	mg/l as CaCO3 (0.02)	27	18	
Total Suspended Solids	mg/l (0.05)	1.7	44	
Ammonia	mg/l as N (0.03)	0.048	74	
Nitrate+Nitrite	mg/l as N (0.01)	0.053	71	
Total Kjeldahl Nitrogen	mg/l as N (0.06)	0.57	13	
Orthophosphorus	mg/l as P (0.01)	0.005	56	
Chloride	mg/l (0.05)	7	7	
Sulfate	mg/l (0.05)	3	14	
Sodium	mg/l (0.06)	2.6	<5	
Potassium	mg/l (0.07)	1.3	22	
Calcium	mg/l (0.04)	8.7	32	
Magnesium	mg/l (0.006)	1.6	18	
Iron	ug/l (0.03)	10	<5	

Based upon the average FTSI of 29, water quality is considered good. Lake Verona can be characterized as a clear (color<=10 color units), soft water, mesotrophic lake, with low concentrations of total phosphorus, low concentrations of total nitrogen. The chemical type of water (predominant ionic composition) is calcium sulfate.

Plots and Trends: No or insufficient data available for plotting or trend detection. Shown is a diagram of the relative ionic composition of the lake water.

MAJOR IONS (% meq/l)

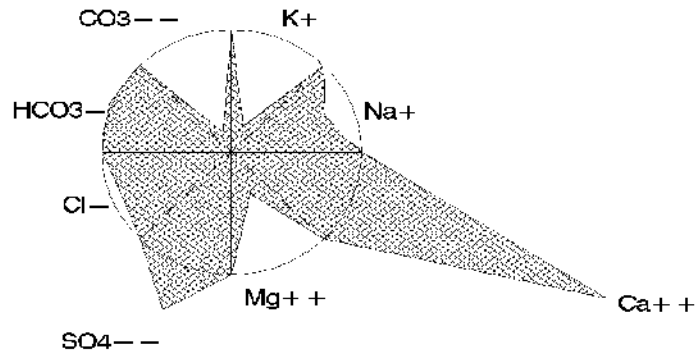

Lake Viola

Highlands County

USGS Quadrangle: Lake Arbuckle SW Major Land Use/Land Cover (1990)
 Section/Township/Range: 14-33S-28E within 500 meters of the lakeshore:
 Approx. Lake Center, Lat/Long: 273646/812941 - tree crops, typically citrus (59%)
 Surface Area: 73 acres - medium density residential (25%)
 Approx. Lake Elevation: 110 feet - low density residential (5%)
 Lake Type: outflow (type 2)
 Major Basin: Kissimmee Ridge
 Minor Basin: Grassy Creek
 Lake Region: Southern Lake Wales Ridge
 Public Access: yes

Total Number of Samples Collected: 10 Most Recent Sample Collected: April 1994

Parameter	Units (Detection Limit)	Average Value	District Percentile	Florida Percentile
Chlorophyll a	ug/l (1)	1.9	11	8
Total Phosphorus	mg/l as P (0.01)	0.009	31	<5
Total Nitrogen	mg/l as N (0.06)	1.31	62	46
Transparency (Secchi depth)	meters	5.40	>95	>95
Florida Trophic State Index		19	6	<5
Specific Conductance	S/cm at 25C (1)	231	71	57
pH	standard units (0.1)	7.4	57	50
Color	PtCo units (1)	4	<5	<5
Turbidity	NTU (1)	1.6	44	14
Total Alkalinity	mg/l as CaCO3 (1)	32	62	51
Hardness	mg/l as CaCO3 (0.02)	59	61	
Total Suspended Solids	mg/l (0.05)	1.1	31	
Ammonia	mg/l as N (0.03)	0.017	60	
Nitrate+Nitrite	mg/l as N (0.01)	0.753	94	
Total Kjeldahl Nitrogen	mg/l as N (0.06)	0.56	12	
Orthophosphorus	mg/l as P (0.01)	0.005	56	
Chloride	mg/l (0.05)	14	30	
Sulfate	mg/l (0.05)	9	34	
Sodium	mg/l (0.06)	3.6	6	
Potassium	mg/l (0.07)	6.5	78	
Calcium	mg/l (0.04)	11.0	43	
Magnesium	mg/l (0.006)	7.9	83	
Iron	ug/l (0.03)	7	<5	

Based upon the average FTSI of 19, water quality is considered good. Lake Viola can be characterized as a clear (color<=10 color units), medium hard water, oligotrophic lake, with low concentrations of total phosphorus. The chemical type of water (predominant ionic composition) is calcium sulfate.

Plots and Trends: No or insufficient data available for plotting or trend detection. Shown is a diagram of the relative ionic composition of the lake water.

MAJOR IONS (% meq/l)

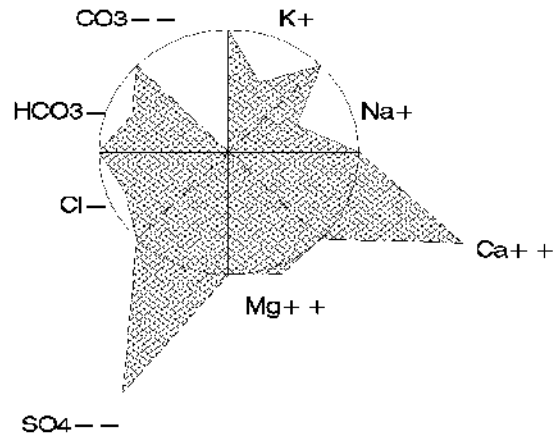

Wolf Lake

Highlands County

USGS Quadrangle: Sebring Major Land Use/Land Cover (1990)
 Section/Township/Range: 24-35S-28E within 500 meters of the lakeshore:
 Approx. Lake Center, Lat/Long: 272519/812825 - open land (48%)
 Surface Area: 122 acres - low density residential (27%)
 Approx. Lake Elevation: 93 feet - cropland and pastureland (8%)
 Lake Type: inflow and outflow (type 3)
 Major Basin: Kissimmee Ridge
 Minor Basin: Unnamed
 Lake Region: Lake Wales Ridge Transition
 Public Access: yes

Total Number of Samples Collected: 10 Most Recent Sample Collected: April 1994

Parameter	Units (Detection Limit)	Average Value	District Percentile	Florida Percentile
Chlorophyll a	ug/l (1)	12.3	70	42
Total Phosphorus	mg/l as P (0.01)	0.217	>95	85
Total Nitrogen	mg/l as N (0.06)	1.39	65	50
Transparency (Secchi depth)	meters	0.38	<5	<5
Florida Trophic State Index		69	94	77
Specific Conductance	S/cm at 25C (1)	84	9	17
pH	standard units (0.1)	5.6	<5	<5
Color	PtCo units (1)	289	>95	>95
Turbidity	NTU (1)	18.4	>95	80
Total Alkalinity	mg/l as CaCO3 (1)	3	7	8
Hardness	mg/l as CaCO3 (0.02)	13	<5	
Total Suspended Solids	mg/l (0.05)	8.3	87	
Ammonia	mg/l as N (0.03)	0.032	63	
Nitrate+Nitrite	mg/l as N (0.01)	0.033	60	
Total Kjeldahl Nitrogen	mg/l as N (0.06)	1.35	71	
Orthophosphorus	mg/l as P (0.01)	0.147	>95	
Chloride	mg/l (0.05)	12	23	
Sulfate	mg/l (0.05)	2	10	
Sodium	mg/l (0.06)	3.8	8	
Potassium	mg/l (0.07)	1.2	21	
Calcium	mg/l (0.04)	3.7	7	
Magnesium	mg/l (0.006)	0.9	<5	
Iron	ug/l (0.03)	168	90	

Based upon the average FTSI of 69, water quality is considered fair. Wolf Lake can be characterized as a highly colored, soft water, meso-eutrophic lake, with high concentrations of total phosphorus. The chemical type of water (predominant ionic composition) is sodium chloride.

Also of note:

- The measured pH was low.

Plots and Trends: Similar to plots of lake elevation for other lakes in the Lake Wales Ridge region, Wolf Lake surface elevations have generally increased during the 1990s, recovering from the drought years in the mid- to late 1980s in the Lake Wales Ridge region. There is no evident trend in Chlorophyll a concentrations. Also shown is a diagram of the relative ionic composition of the lake water.

MONTHLY AVERAGE SURFACE ELEVATION

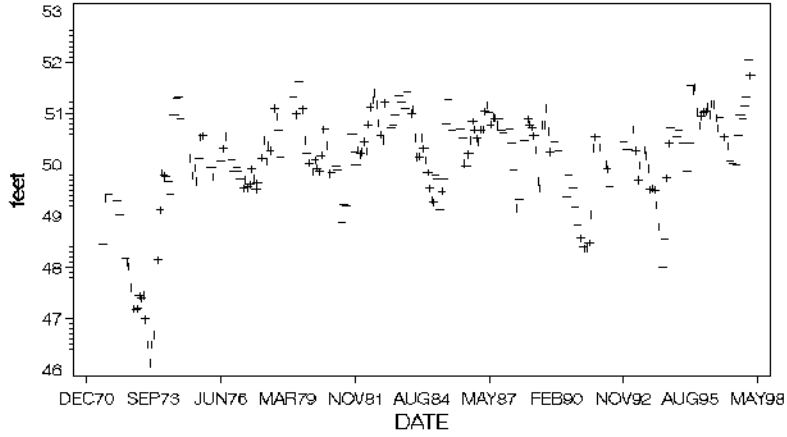

CHLOROPHYLL a

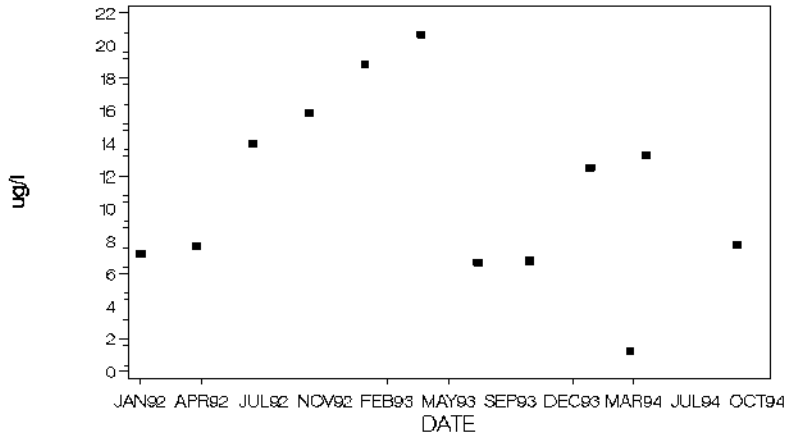

MAJOR IONS (% meq/l)

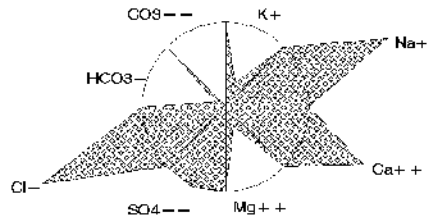

Wolf Lake, Highlands County

Lake Alice

Hillsborough County

USGS Quadrangle: Odessa
 Section/Township/Range: 16-27S-17E
 Approx. Lake Center, Lat/Long: 280753/823616
 Surface Area: 93 acres
 Approx. Lake Elevation: 43 feet
 Average Depth: 6.2 feet
 Observed Maximum Depth: 23.8 feet
 (reference elevation 42.8 feet)
 Lake Type: isolated (type 4)
 Major Basin: Tampa Bay Drainage
 Minor Basin: Unnamed Ditch
 Lake Region: Keystone Lakes

Major Land Use/Land Cover (1990)
 within 500 meters of the lakeshore:
 - medium density residential (39%)
 - other open lands - rural (26%)
 - tree crops, typically citrus (11%)

Total Number of Samples Collected: 2 Most Recent Sample Collected: January 1996

Parameter	Units (Detection Limit)	Average Value	District Percentile	Florida Percentile
Chlorophyll a	ug/l (1)	2.4	17	10
Total Phosphorus	mg/l as P (0.01)	0.008	31	<5
Total Nitrogen	mg/l as N (0.06)	0.92	34	31
Transparency (Secchi depth)	meters	5.00	>95	>95
Florida Trophic State Index		21	8	<5
Specific Conductance	S/cm at 25C (1)	136	29	38
pH	standard units (0.1)	4.5	<5	<5
Color	PtCo units (1)	5	9	5
Turbidity	NTU (1)	0.5	28	<5
Total Alkalinity	mg/l as CaCO3 (1)	1	<5	<5
Hardness	mg/l as CaCO3 (0.02)	24	13	
Total Suspended Solids	mg/l (0.05)	0.3	<5	
Ammonia	mg/l as N (0.03)	0.138	92	
Nitrate+Nitrite	mg/l as N (0.01)	0.022	54	
Total Kjeldahl Nitrogen	mg/l as N (0.06)	0.90	39	
Orthophosphorus	mg/l as P (0.01)	0.008	56	
Chloride	mg/l (0.05)	19	51	
Sulfate	mg/l (0.05)	23	67	
Sodium	mg/l (0.06)	11.0	64	
Potassium	mg/l (0.07)	2.2	37	
Calcium	mg/l (0.04)	5.4	16	
Magnesium	mg/l (0.006)	2.5	36	
Iron	ug/l (0.03)	29	36	

Based upon the average FTSI of 21, water quality is considered good. Lake Alice can be characterized as a clear (color<=10 PtCo units), soft water, oligo-mesotrophic lake, with low concentrations of total phosphorus. The chemical type of water (predominant ionic composition) is sodium chloride.

Also of note:

- the measured pH was very low

Plots and Trends: No clear trends evident in the historical data. Also shown is a diagram of the relative ionic composition of the lake water.

MONTHLY AVERAGE SURFACE ELEVATION

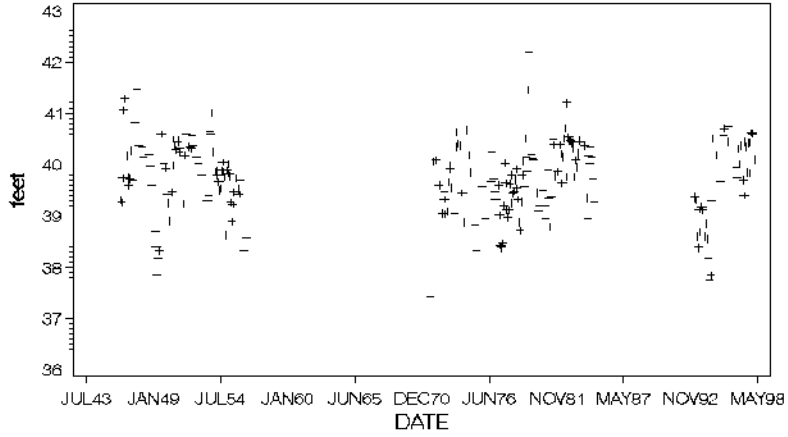

SPEC. CONDUCTANCE

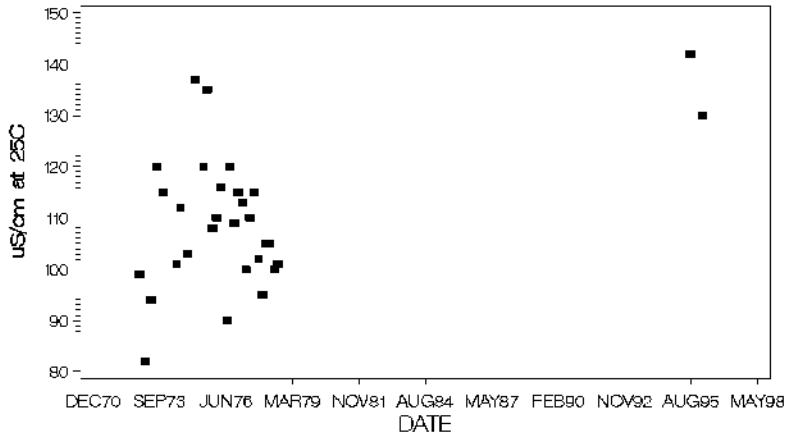

MAJOR IONS (% meq/l)

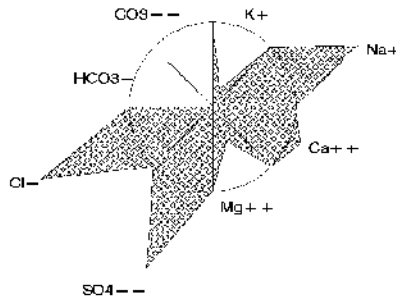

Lake Alice, Hillsborough County

Lake Allen

Hillsborough County

USGS Quadrangle: Lutz Major Land Use/Land Cover (1990)
 Section/Township/Range: 10-27S-18E within 500 meters of the lakeshore:
 Approx. Lake Center, Lat/Long: 280924/822920 - medium density residential (30%)
 Surface Area: 28 acres - cypress (10%)
 Approx. Lake Elevation: 63 feet - hardwood - conifer mixed (10%)
 Lake Type: inflow (type 1)
 Major Basin: Tampa Bay Drainage
 Minor Basin: Upper Rocky Creek
 Lake Region: Land-o-Lakes

Total Number of Samples Collected: 2 Most Recent Sample Collected: January 1995

Parameter	Units (Detection Limit)	Average Value	District Percentile	Florida Percentile
Chlorophyll a	ug/l (1)	10.0	64	38
Total Phosphorus	mg/l as P (0.01)	0.015	53	8
Total Nitrogen	mg/l as N (0.06)	2.18	87	84
Transparency (Secchi depth)	meters	1.33	46	73
Florida Trophic State Index		47	69	29
Specific Conductance	S/cm at 25C (1)	185	53	49
pH	standard units (0.1)	7.4	57	50
Color	PtCo units (1)	23	58	19
Turbidity	NTU (1)	2.6	59	28
Total Alkalinity	mg/l as CaCO3 (1)	9	24	24
Hardness	mg/l as CaCO3 (0.02)	33	26	
Total Suspended Solids	mg/l (0.05)	2.0	51	
Ammonia	mg/l as N (0.03)	0.015	60	
Nitrate+Nitrite	mg/l as N (0.01)	0.005	33	
Total Kjeldahl Nitrogen	mg/l as N (0.06)	2.18	94	
Orthophosphorus	mg/l as P (0.01)	0.005	56	
Chloride	mg/l (0.05)	26	78	
Sulfate	mg/l (0.05)	15	50	
Sodium	mg/l (0.06)	12.8	74	
Potassium	mg/l (0.07)	3.8	52	
Calcium	mg/l (0.04)	8.6	31	
Magnesium	mg/l (0.006)	2.7	40	
Iron	ug/l (0.03)	30	38	

Based upon the average FTSI of 47, water quality is considered good. Lake Allen can be characterized as a moderately colored, soft water, eutrophic lake, with high concentrations of total nitrogen. The chemical type of water (predominant ionic composition) is sodium chloride.

Plots and Trends: No trends are evident in the historical data. Also shown is a diagram of the relative ionic composition of the lake water.

MONTHLY AVERAGE SURFACE ELEVATION

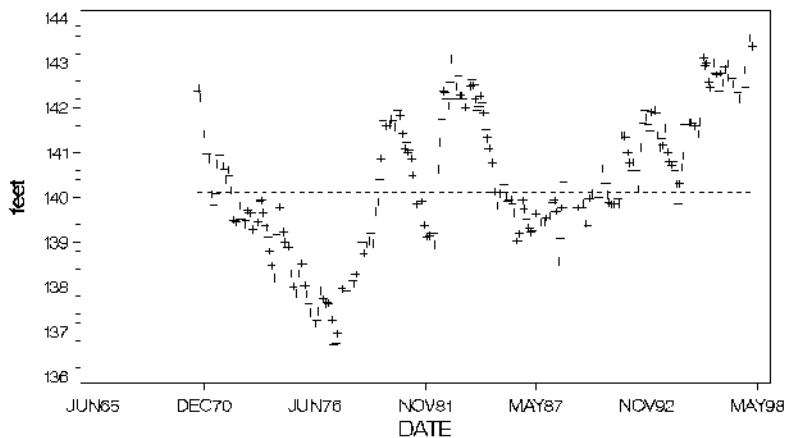

SPEC. CONDUCTANCE

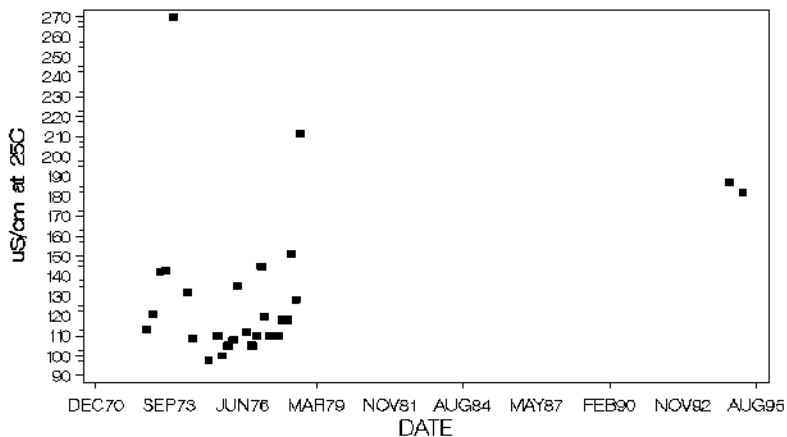

MAJOR IONS (% meq/l)

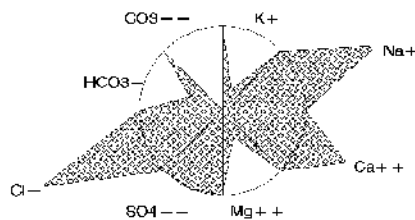

Lake Allen, Hillsborough County

Lake Barbara

Hillsborough County

USGS Quadrangle: Citrus Park Major Land Use/Land Cover (1990)
 Section/Township/Range: 19-27S-18E within 500 meters of the lakeshore:
 Approx. Lake Center, Lat/Long: 280710/823209 - low density residential (52%)
 Surface Area: 4 acres - cypress (16%)
 Approx. Lake Elevation: 53 feet - medium density residential (11%)
 Lake Type: outflow (type 2)
 Major Basin: Tampa Bay Drainage
 Minor Basin: Upper Rocky Creek
 Lake Region: Keystone Lakes

Total Number of Samples Collected: 2 Most Recent Sample Collected: January 1997

Parameter	Units (Detection Limit)	Average Value	District Percentile	Florida Percentile
Chlorophyll a	ug/l (1)	3.8	34	16
Total Phosphorus	mg/l as P (0.01)	0.013	46	7
Total Nitrogen	mg/l as N (0.06)	0.93	35	31
Transparency (Secchi depth)	meters		-	-
Florida Trophic State Index		35	40	9
Specific Conductance	S/cm at 25C (1)	298	88	69
pH	standard units (0.1)	6.5	15	18
Color	PtCo units (1)	25	62	20
Turbidity	NTU (1)	0.5	28	<5
Total Alkalinity	mg/l as CaCO3 (1)	29	57	48
Hardness	mg/l as CaCO3 (0.02)	48	50	
Total Suspended Solids	mg/l (0.05)	1.2	33	
Ammonia	mg/l as N (0.03)	0.032	63	
Nitrate+Nitrite	mg/l as N (0.01)	0.005	33	
Total Kjeldahl Nitrogen	mg/l as N (0.06)	0.92	40	
Orthophosphorus	mg/l as P (0.01)	0.008	56	
Chloride	mg/l (0.05)	67	>95	
Sulfate	mg/l (0.05)	13	45	
Sodium	mg/l (0.06)	36.5	>95	
Potassium	mg/l (0.07)	1.9	32	
Calcium	mg/l (0.04)	15.5	62	
Magnesium	mg/l (0.006)	2.3	33	
Iron	ug/l (0.03)	44	57	

Based upon the average FTSI of 35, water quality is considered good. Lake Barbara can be characterized as a moderately colored, soft water, oligo-mesotrophic lake. The chemical type of water (predominant ionic composition) is sodium chloride.

Also of note:

- Cattails dominate more than 30% of the lake shoreline.

Plots and Trends: No or insufficient data for plotting or trend detection. Shown is a diagram of the relative ionic composition of the lake water.

MAJOR IONS (% meq/l)

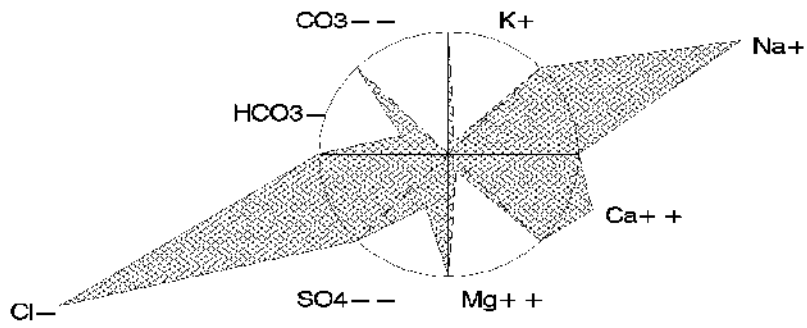

Bay Lake

Hillsborough County

USGS Quadrangle: Citrus Park Major Land Use/Land Cover (1990)
 Section/Township/Range: 4-28S-18E within 500 meters of the lakeshore:
 Approx. Lake Center, Lat/Long: 280414/823004 - medium density residential (47%)
 Surface Area: 38 acres - commercial and services (21%)
 Approx. Lake Elevation: 47 feet - high density residential (18%)
 Lake Type: inflow and outflow (type 3)
 Major Basin: Tampa Bay Drainage
 Minor Basin: Sweetwater Creek
 Lake Region: Land-o-Lakes

Total Number of Samples Collected: 2 Most Recent Sample Collected: January 1995

Parameter	Units (Detection Limit)	Average Value	District Percentile	Florida Percentile
Chlorophyll a	ug/l (1)	21.8	81	54
Total Phosphorus	mg/l as P (0.01)	0.023	69	13
Total Nitrogen	mg/l as N (0.06)	1.63	73	67
Transparency (Secchi depth)	meters	0.75	21	45
Florida Trophic State Index		59	82	53
Specific Conductance	S/cm at 25C (1)	200	58	52
pH	standard units (0.1)	7.8	74	63
Color	PtCo units (1)	20	55	17
Turbidity	NTU (1)	5.6	76	53
Total Alkalinity	mg/l as CaCO3 (1)	40	71	56
Hardness	mg/l as CaCO3 (0.02)	63	65	
Total Suspended Solids	mg/l (0.05)	4.6	76	
Ammonia	mg/l as N (0.03)	0.036	66	
Nitrate+Nitrite	mg/l as N (0.01)	0.005	33	
Total Kjeldahl Nitrogen	mg/l as N (0.06)	1.63	81	
Orthophosphorus	mg/l as P (0.01)	0.005	56	
Chloride	mg/l (0.05)	27	80	
Sulfate	mg/l (0.05)	12	41	
Sodium	mg/l (0.06)	11.5	66	
Potassium	mg/l (0.07)	2.1	35	
Calcium	mg/l (0.04)	21.5	80	
Magnesium	mg/l (0.006)	2.2	31	
Iron	ug/l (0.03)	34	45	

Based upon the average FTSI of 59, water quality is considered good. Bay Lake can be characterized as a moderately colored, medium hard water, eutrophic lake. The chemical type of water (predominant ionic composition) is calcium chloride.

Plots and Trends: Hardness and total alkalinity were greater for the two samples collected in 1994 and 1995 than for samples collected in the late 1960s, however, there are insufficient data to conclude that this difference represents a trend. Also shown is a diagram of the relative ionic composition of the lake water.

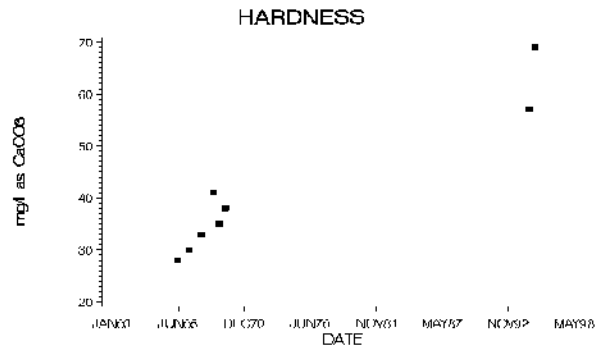
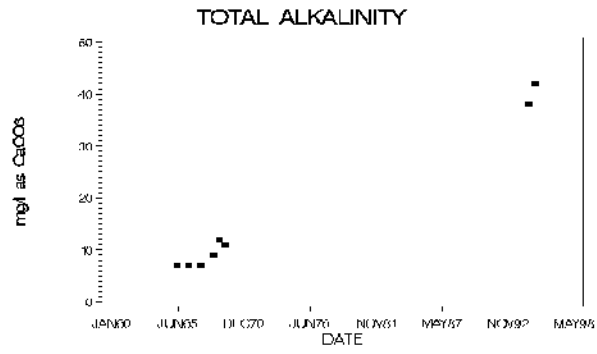
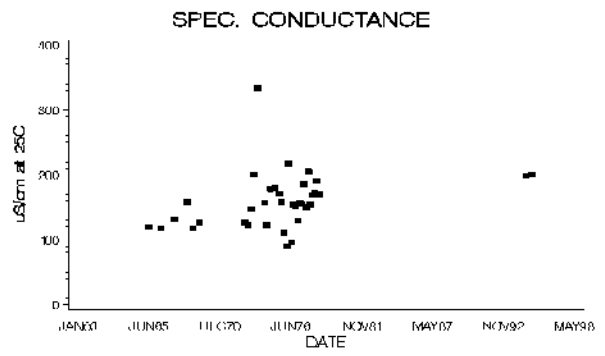
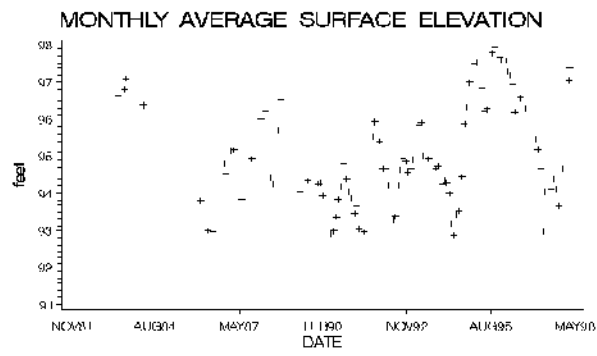

MAJOR IONS (% meq/l)

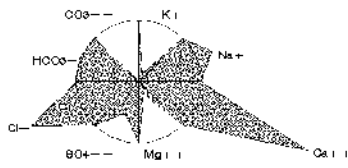

Bellows (East) Lake Hillsborough County

USGS Quadrangle:	Tampa	Major Land Use/Land Cover (1990)
Section/Township/Range:	2-29S-19E	within 500 meters of the lakeshore:
Approx. Lake Center, Lat/Long:	275923/822249	- commercial and services (35%)
Surface Area:	88 acres	- high density residential (21%)
Approx. Lake Elevation:	24 feet	- transportation (10%)
Lake Type:	outflow (type 2)	
Major Basin:	Tampa Bay Drainage	
Minor Basin:	Bellows Lake Outlet	
Lake Region:	Hillsborough Valley	

Total Number of Samples Collected: 2 Most Recent Sample Collected: January 1996

Parameter	Units (Detection Limit)	Average Value	District Percentile	Florida Percentile
Chlorophyll a	ug/l (1)	58.7	95	86
Total Phosphorus	mg/l as P (0.01)	0.065	90	48
Total Nitrogen	mg/l as N (0.06)	1.72	76	71
Transparency (Secchi depth)	meters	0.43	<5	10
Florida Trophic State Index		73	>95	87
Specific Conductance	S/cm at 25C (1)	151	39	42
pH	standard units (0.1)	9.5	>95	>95
Color	PtCo units (1)	20	55	17
Turbidity	NTU (1)	18.7	>95	81
Total Alkalinity	mg/l as CaCO3 (1)	45	76	59
Hardness	mg/l as CaCO3 (0.02)	58	60	
Total Suspended Solids	mg/l (0.05)	34.0	>95	
Ammonia	mg/l as N (0.03)	0.015	60	
Nitrate+Nitrite	mg/l as N (0.01)	0.019	50	
Total Kjeldahl Nitrogen	mg/l as N (0.06)	1.70	83	
Orthophosphorus	mg/l as P (0.01)	0.017	83	
Chloride	mg/l (0.05)	9	12	
Sulfate	mg/l (0.05)	13	45	
Sodium	mg/l (0.06)	5.0	12	
Potassium	mg/l (0.07)	1.9	32	
Calcium	mg/l (0.04)	21.0	78	
Magnesium	mg/l (0.006)	1.4	15	
Iron	ug/l (0.03)	76	73	

Based upon the average FTSI of 73, water quality is considered poor. Bellows (East) Lake can be characterized as a moderately colored, soft water, eutrophic to hypereutrophic lake, with high concentrations of total phosphorus. The chemical type of water (predominant ionic composition) is calcium bicarbonate.

Also of note:

- The measured pH was very high.
- Cattails dominate more than 30% of the lake shoreline.

Plots and Trends: No or insufficient data for plotting or trend detection. Shown is a diagram of the relative ionic composition of the lake water.

MAJOR IONS (% meq/l)

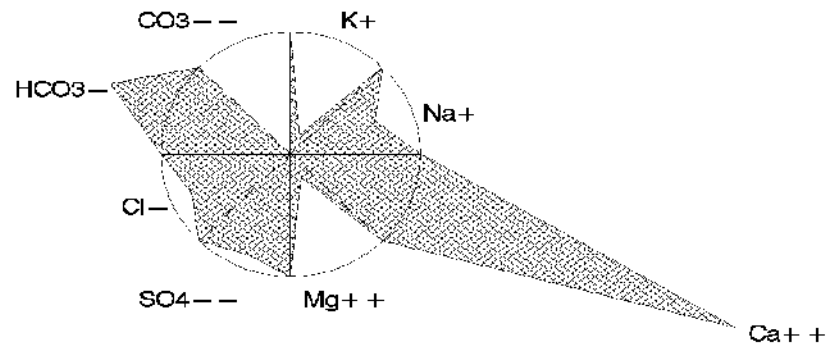

Bellows (East) Lake, Hillsborough County

Brant Lake

Hillsborough County

USGS Quadrangle: Lutz Major Land Use/Land Cover (1990)
 Section/Township/Range: 23-27S-18E within 500 meters of the lakeshore:
 Approx. Lake Center, Lat/Long: 280733/822819 - medium density residential (46%)
 Surface Area: 60 acres - cropland and pastureland (14%)
 Approx. Lake Elevation: 59 feet - cypress (9%)
 Average Depth: 6.1 feet
 Observed Maximum Depth: 16 feet
 (reference elevation 58 feet)
 Lake Type: isolated (type 4)
 Major Basin: Tampa Bay Drainage
 Minor Basin: Lake Drainage Ditch
 Lake Region: Land-o-Lakes

Total Number of Samples Collected: 13 Most Recent Sample Collected: April 1997

Parameter	Units (Detection Limit)	Average Value	District Percentile	Florida Percentile
Chlorophyll a	ug/l (1)	18.7	78	50
Total Phosphorus	mg/l as P (0.01)	0.038	82	28
Total Nitrogen	mg/l as N (0.06)	1.22	56	41
Transparency (Secchi depth)	meters	0.91	29	60
Florida Trophic State Index		53	77	40
Specific Conductance	S/cm at 25C (1)	194	57	51
pH	standard units (0.1)	7.3	50	45
Color	PtCo units (1)	77	85	65
Turbidity	NTU (1)	4.8	74	48
Total Alkalinity	mg/l as CaCO3 (1)	27	54	46
Hardness	mg/l as CaCO3 (0.02)	40	36	
Total Suspended Solids	mg/l (0.05)	4.8	77	
Ammonia	mg/l as N (0.03)	0.030	61	
Nitrate+Nitrite	mg/l as N (0.01)	0.023	56	
Total Kjeldahl Nitrogen	mg/l as N (0.06)	1.20	62	
Orthophosphorus	mg/l as P (0.01)	0.013	72	
Chloride	mg/l (0.05)	30	85	
Sulfate	mg/l (0.05)	9	34	
Sodium	mg/l (0.06)	15.9	86	
Potassium	mg/l (0.07)	4.2	58	
Calcium	mg/l (0.04)	14.6	59	
Magnesium	mg/l (0.006)	3.2	48	
Iron	ug/l (0.03)	58	67	

Based upon the average FTSI of 53, water quality is considered good. Brant Lake can be characterized as a colored, soft water, eutrophic lake, with high concentrations of total phosphorus. The chemical type of water (predominant ionic composition) is sodium chloride (8 samples) or calcium chloride (5 samples).

Also of note:

- Melaleuca was observed on the lake shore.

Plots and Trends: The lake surface elevation has varied by 8 feet over the 28-year period of record. There is no trend in elevation. Though it appears the conductivity is generally greater in the 1990s than for measurements made in the 1970s, it is not possible to determine if there is a trend in conductivity due to the interrupted period of record, Also shown is a diagram of the relative ionic composition of the lake water.

MONTHLY AVERAGE SURFACE ELEVATION

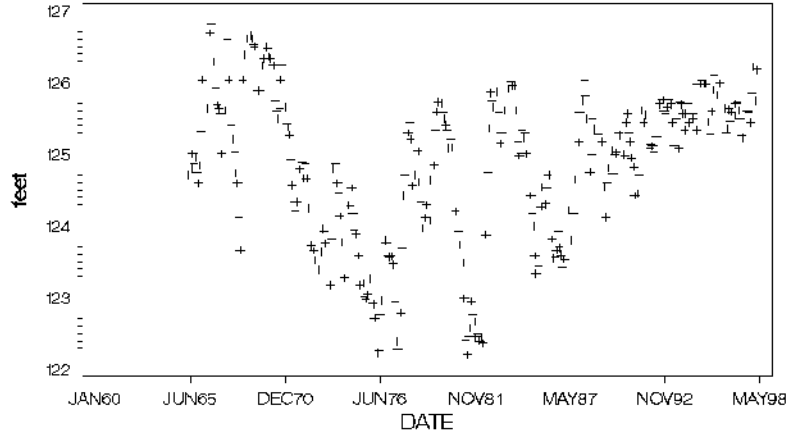

SPEC. CONDUCTANCE

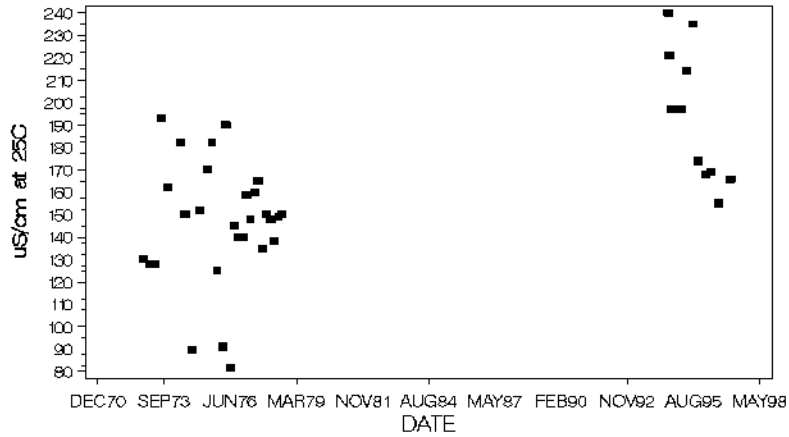

MAJOR IONS (% meq/l)

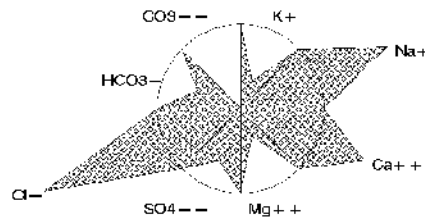

Calm Lake

Hillsborough County

USGS Quadrangle: Odessa Major Land Use/Land Cover (1990)
 Section/Township/Range: 14-27S-17E within 500 meters of the lakeshore:
 Approx. Lake Center, Lat/Long: 280831/823456 - tree crops, typically citrus (24%)
 Surface Area: 127 acres - cropland and pastureland (17%)
 Approx. Lake Elevation: 51 feet - medium density residential (14%)
 Average Depth: 9.4 feet
 Observed Maximum Depth: 25.4 feet
 (reference elevation 50.4 feet)
 Lake Type: isolated (type 4)
 Major Basin: Tampa Bay Drainage
 Minor Basin: Upper Brooker Creek
 Lake Region: Keystone Lakes

Total Number of Samples Collected: 2 Most Recent Sample Collected: February 1997

Parameter	Units (Detection Limit)	Average Value	District Percentile	Florida Percentile
Chlorophyll a	ug/l (1)	2.5	18	11
Total Phosphorus	mg/l as P (0.01)	0.008	31	<5
Total Nitrogen	mg/l as N (0.06)	0.31	<5	<5
Transparency (Secchi depth)	meters	-	-	-
Florida Trophic State Index		30	27	5
Specific Conductance	S/cm at 25C (1)	180	50	48
pH	standard units (0.1)	6.8	25	25
Color	PtCo units (1)	5	9	5
Turbidity	NTU (1)	0.5	28	<5
Total Alkalinity	mg/l as CaCO3 (1)	5	13	13
Hardness	mg/l as CaCO3 (0.02)	43	41	
Total Suspended Solids	mg/l (0.05)	0.9	24	
Ammonia	mg/l as N (0.03)	0.015	60	
Nitrate+Nitrite	mg/l as N (0.01)	0.055	71	
Total Kjeldahl Nitrogen	mg/l as N (0.06)	0.25	<5	
Orthophosphorus	mg/l as P (0.01)	0.008	56	
Chloride	mg/l (0.05)	18	46	
Sulfate	mg/l (0.05)	37	86	
Sodium	mg/l (0.06)	11.5	66	
Potassium	mg/l (0.07)	5.1	66	
Calcium	mg/l (0.04)	11.0	43	
Magnesium	mg/l (0.006)	3.8	56	
Iron	ug/l (0.03)	12	5	

Based upon the average FTSI of 30, water quality is considered good. Calm Lake can be characterized as a clear (color<=10 color units), soft water, oligotrophic lake, with low concentrations of total phosphorus, very low concentrations of total nitrogen. The chemical type of water (predominant ionic composition) is calcium sulfate.

Also of note:

- Melaleuca was observed on the lake shore.

Plots and Trends: The range in lake surface elevation over the period of record was between 6 and 7 feet. Though there are insufficient data to determine trends, hardness was about 10 mg/l less in samples collected in 1996 and 1997 than for samples collected between 1964 and 1970. Also shown is a diagram of the relative ionic composition of the lake water.

MONTHLY AVERAGE SURFACE ELEVATION

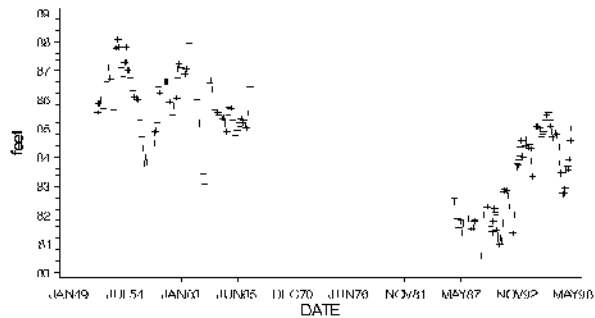

SPEC. CONDUCTANCE

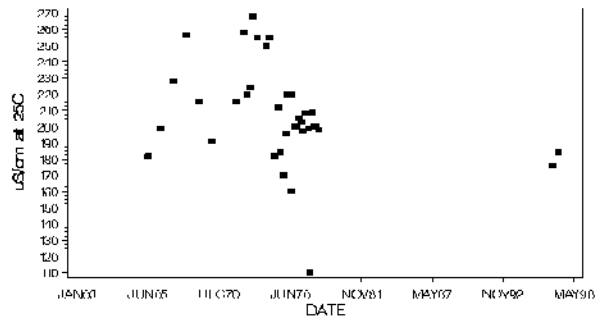

TOTAL ALKALINITY

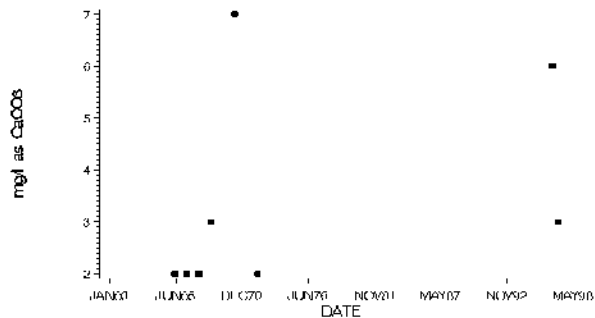

HARDNESS

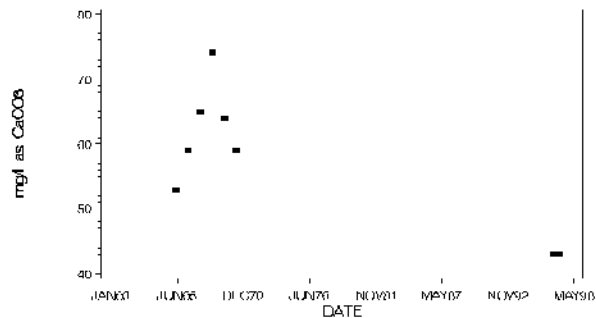

MAJOR IONS (% meq/l)

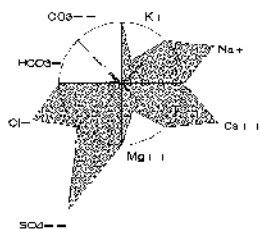

Lake Carroll

Hillsborough County

USGS Quadrangle: Sulphur Springs Major Land Use/Land Cover (1990)
 Section/Township/Range: 15-28S-18E within 500 meters of the lakeshore:
 Approx. Lake Center, Lat/Long: 280304/822914 - high density residential (64%)
 Surface Area: 191 acres - medium density residential (16%)
 Approx. Lake Elevation: 37 feet - low density residential (9%)
 Average Depth: 10.5 feet
 Observed Maximum Depth: 20 feet
 (reference elevation 35.5 feet)
 Lake Type: outflow (type 2)
 Major Basin: Tampa Bay Drainage
 Minor Basin: Sweetwater Creek
 Lake Region: Land-o-Lakes

Total Number of Samples Collected: 2 Most Recent Sample Collected: February 1997

Parameter	Units (Detection Limit)	Average Value	District Percentile	Florida Percentile
Chlorophyll a	ug/l (1)	3.1	26	13
Total Phosphorus	mg/l as P (0.01)	0.008	31	<5
Total Nitrogen	mg/l as N (0.06)	0.51	5	11
Transparency (Secchi depth)	meters	3.66	91	>95
Florida Trophic State Index		24	12	<5
Specific Conductance	S/cm at 25C (1)	206	62	53
pH	standard units (0.1)	7.3	50	45
Color	PtCo units (1)	8	24	8
Turbidity	NTU (1)	0.5	28	<5
Total Alkalinity	mg/l as CaCO3 (1)	31	60	50
Hardness	mg/l as CaCO3 (0.02)	63	65	
Total Suspended Solids	mg/l (0.05)	0.7	18	
Ammonia	mg/l as N (0.03)	0.015	60	
Nitrate+Nitrite	mg/l as N (0.01)	0.064	75	
Total Kjeldahl Nitrogen	mg/l as N (0.06)	0.45	6	
Orthophosphorus	mg/l as P (0.01)	0.005	56	
Chloride	mg/l (0.05)	25	76	
Sulfate	mg/l (0.05)	26	72	
Sodium	mg/l (0.06)	14.0	80	
Potassium	mg/l (0.07)	2.1	35	
Calcium	mg/l (0.04)	21.5	80	
Magnesium	mg/l (0.006)	2.2	31	
Iron	ug/l (0.03)	6	<5	

Based upon the average FTSI of 24, water quality is considered good. Lake Carroll can be characterized as a clear (color<=10 color units), medium hard water, oligo-mesotrophic lake, with low concentrations of total phosphorus and very low concentrations of total nitrogen. The chemical type of water (predominant ionic composition) is calcium chloride.

Plots and Trends: Water quality in Lake Carroll has been quite variable over the 30-year period of record. For pH, all of the values for samples collected between 1965 and 1970 were lower than samples collected between 1979 and 1997. Also shown is a diagram of the relative ionic composition of the lake water.

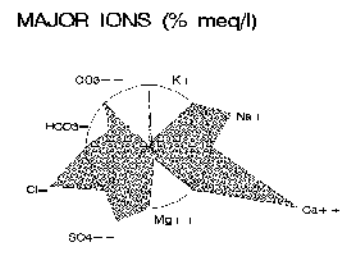
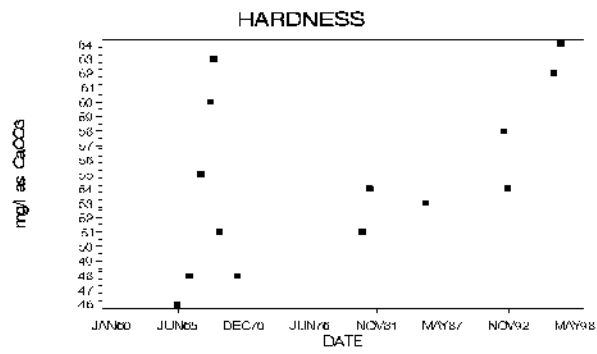
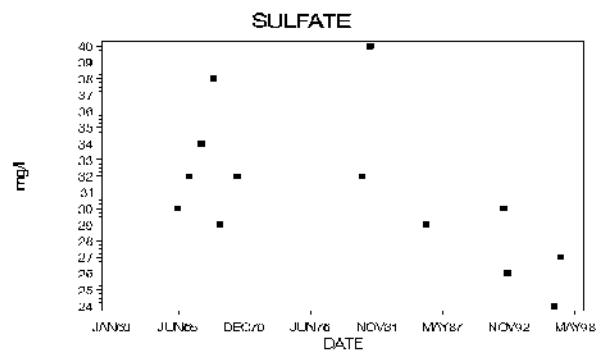
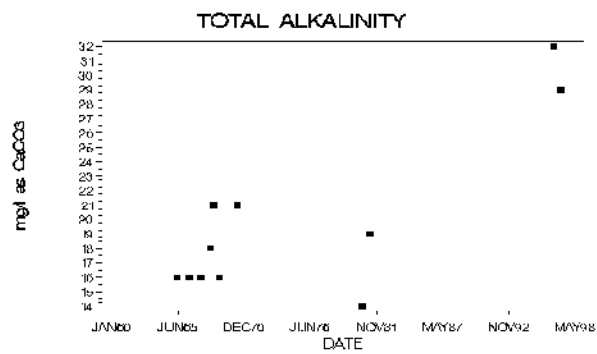
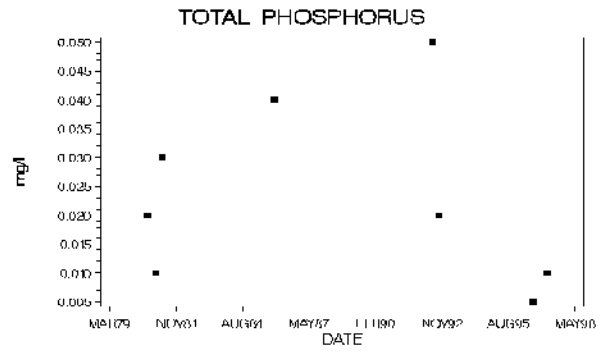
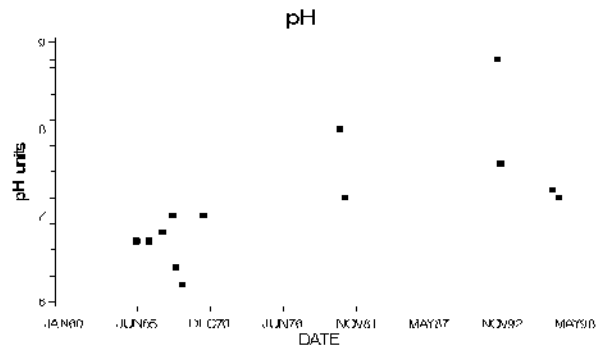
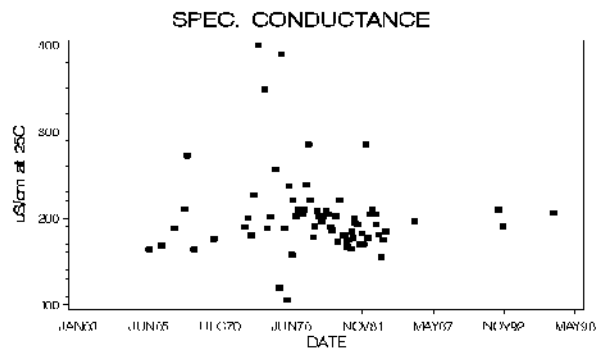
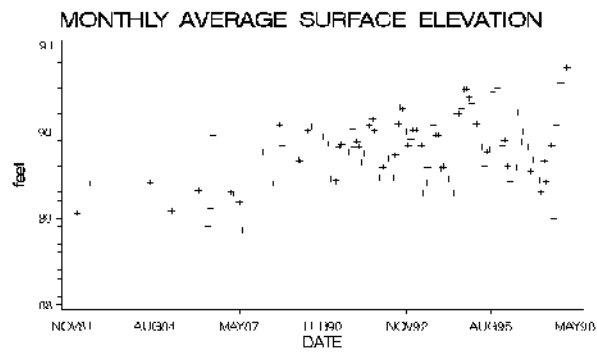

Lake Carroll, Hillsborough County

Cedar Lake Hillsborough County

USGS Quadrangle: Sulphur Springs Major Land Use/Land Cover (1990)
 Section/Township/Range: 11-28S-18E within 500 meters of the lakeshore:
 Approx. Lake Center, Lat/Long: 280354/822823 - high density residential (55%)
 Surface Area: 10 acres - medium density residential (22%)
 Approx. Lake Elevation: 35 feet - hardwood - conifer mixed (9%)
 Lake Type: inflow and outflow (type 3)
 Major Basin: Hillsborough River
 Minor Basin: Curiosity Creek
 Lake Region: Land-o-Lakes

Total Number of Samples Collected: 2 Most Recent Sample Collected: January 1996

Parameter	Units (Detection Limit)	Average Value	District Percentile	Florida Percentile
Chlorophyll a	ug/l (1)	19.0	79	51
Total Phosphorus	mg/l as P (0.01)	0.020	65	10
Total Nitrogen	mg/l as N (0.06)	1.85	81	78
Transparency (Secchi depth)	meters	0.95	31	62
Florida Trophic State Index		52	76	39
Specific Conductance	S/cm at 25C (1)	230	70	57
pH	standard units (0.1)	7.7	69	60
Color	PtCo units (1)	13	41	12
Turbidity	NTU (1)	4.7	73	48
Total Alkalinity	mg/l as CaCO3 (1)	34	64	52
Hardness	mg/l as CaCO3 (0.02)	50	53	
Total Suspended Solids	mg/l (0.05)	6.8	85	
Ammonia	mg/l as N (0.03)	0.015	60	
Nitrate+Nitrite	mg/l as N (0.01)	0.042	66	
Total Kjeldahl Nitrogen	mg/l as N (0.06)	1.81	85	
Orthophosphorus	mg/l as P (0.01)	0.008	56	
Chloride	mg/l (0.05)	33	89	
Sulfate	mg/l (0.05)	21	63	
Sodium	mg/l (0.06)	22.0	94	
Potassium	mg/l (0.07)	2.4	39	
Calcium	mg/l (0.04)	18.0	69	
Magnesium	mg/l (0.006)	1.2	10	
Iron	ug/l (0.03)	79	75	

Based upon the average FTSI of 52, water quality is considered good. Cedar Lake can be characterized as a clear to moderately colored (10<color<20 color units), soft water, eutrophic lake, with high concentrations of total nitrogen. The chemical type of water (predominant ionic composition) is calcium chloride (1 sample) or sodium chloride (1 sample).

Plots and Trends: No or insufficient data for plotting or trend detection. Shown is a diagram of the relative ionic composition of the lake water.

MAJOR IONS (% meq/l)

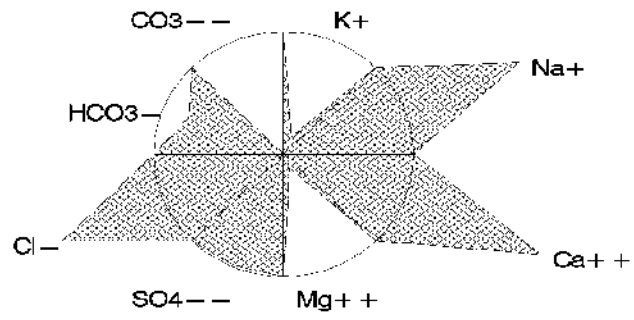

Cedar Lake (East) Hillsborough County

USGS Quadrangle: Sulphur Springs Major Land Use/Land Cover (1990)
 Section/Township/Range: 11-28S-18E within 500 meters of the lakeshore:
 Approx. Lake Center, Lat/Long: 280357/822814 - high density residential (59%)
 Surface Area: 6 acres - medium density residential (15%)
 Approx. Lake Elevation: 35 feet - hardwood - conifer mixed (10%)
 Lake Type: inflow and outflow (type 3)
 Major Basin: Hillsborough River
 Minor Basin: Curiosity Creek
 Lake Region: Land-o-Lakes

Total Number of Samples Collected: 2 Most Recent Sample Collected: January 1996

Parameter	Units (Detection Limit)	Average Value	District Percentile	Florida Percentile
Chlorophyll a	ug/l (1)	2.9	23	12
Total Phosphorus	mg/l as P (0.01)	0.015	53	8
Total Nitrogen	mg/l as N (0.06)	0.86	29	28
Transparency (Secchi depth)	meters	1.50	49	76
Florida Trophic State Index		34	37	8
Specific Conductance	S/cm at 25C (1)	184	52	49
pH	standard units (0.1)	6.8	25	25
Color	PtCo units (1)	23	58	19
Turbidity	NTU (1)	0.5	28	<5
Total Alkalinity	mg/l as CaCO3 (1)	37	69	54
Hardness	mg/l as CaCO3 (0.02)	56	58	
Total Suspended Solids	mg/l (0.05)	0.6	15	
Ammonia	mg/l as N (0.03)	0.069	82	
Nitrate+Nitrite	mg/l as N (0.01)	0.027	58	
Total Kjeldahl Nitrogen	mg/l as N (0.06)	0.84	35	
Orthophosphorus	mg/l as P (0.01)	0.005	56	
Chloride	mg/l (0.05)	19	51	
Sulfate	mg/l (0.05)	18	55	
Sodium	mg/l (0.06)	10.5	62	
Potassium	mg/l (0.07)	3.2	48	
Calcium	mg/l (0.04)	18.5	71	
Magnesium	mg/l (0.006)	2.2	31	
Iron	ug/l (0.03)	73	72	

Based upon the average FTSI of 34, water quality is considered good. Cedar Lake (East) can be characterized as a moderately colored, soft water, oligo-mesotrophic lake. The chemical type of water (predominant ionic composition) is calcium chloride.

Also of note:

- Melaleuca was observed on the lake shore. -

Plots and Trends: No or insufficient data for plotting or trend detection. Shown is a diagram of the relative ionic composition of the lake water.

MAJOR IONS (% meq/l)

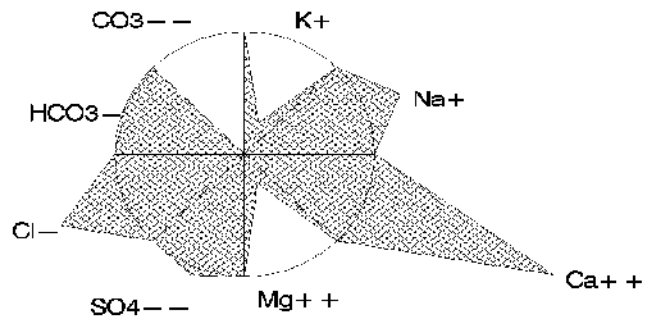

Cedar Lake (East), Hillsborough County

Chapman Lake Hillsborough County

USGS Quadrangle: Sulphur Springs Major Land Use/Land Cover (1990)
 Section/Township/Range: 25-27S-18E within 500 meters of the lakeshore:
 Approx. Lake Center, Lat/Long: 280619/822751 - medium density residential (39%)
 Surface Area: 43 acres - recreational (13%)
 Approx. Lake Elevation: 52 feet - open land (8%)
 Lake Type: inflow and outflow (type 3)
 Major Basin: Tampa Bay Drainage
 Minor Basin: Chapman Lake Outlet
 Lake Region: Land-o-Lakes

Total Number of Samples Collected: 2 Most Recent Sample Collected: January 1995

Parameter	Units (Detection Limit)	Average Value	District Percentile	Florida Percentile
Chlorophyll a	ug/l (1)	3.5	31	14
Total Phosphorus	mg/l as P (0.01)	0.031	77	21
Total Nitrogen	mg/l as N (0.06)	1.50	69	60
Transparency (Secchi depth)	meters	1.70	56	80
Florida Trophic State Index		41	54	17
Specific Conductance	S/cm at 25C (1)	256	79	61
pH	standard units (0.1)	7.3	50	45
Color	PtCo units (1)	30	67	23
Turbidity	NTU (1)	1.0	29	5
Total Alkalinity	mg/l as CaCO3 (1)	46	77	60
Hardness	mg/l as CaCO3 (0.02)	69	71	
Total Suspended Solids	mg/l (0.05)	1.0	28	
Ammonia	mg/l as N (0.03)	0.139	93	
Nitrate+Nitrite	mg/l as N (0.01)	0.111	83	
Total Kjeldahl Nitrogen	mg/l as N (0.06)	1.39	74	
Orthophosphorus	mg/l as P (0.01)	0.015	80	
Chloride	mg/l (0.05)	36	93	
Sulfate	mg/l (0.05)	16	52	
Sodium	mg/l (0.06)	18.0	90	
Potassium	mg/l (0.07)	3.8	52	
Calcium	mg/l (0.04)	22.0	81	
Magnesium	mg/l (0.006)	3.3	49	
Iron	ug/l (0.03)	35	47	

Based upon the average FTSI of 41, water quality is considered good. Chapman Lake can be characterized as a moderately colored, medium hard water, oligo-mesotrophic lake. The chemical type of water (predominant ionic composition) is calcium chloride.

Plots and Trends: There are no trends evident in the available data for lake elevation or conductivity. The two most recently collected samples (1994 and 1995) had the greatest conductivities compared to samples collected during the 1960 and 1970s. Also shown is a diagram of the relative ionic composition of the lake water.

MONTHLY AVERAGE SURFACE ELEVATION

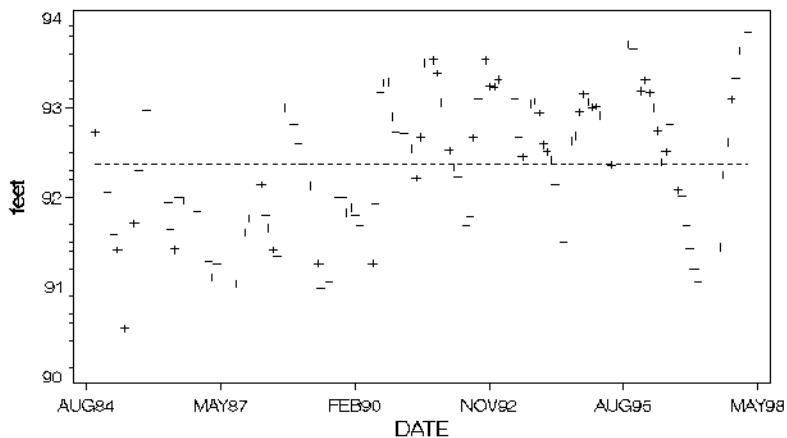

SPEC. CONDUCTANCE

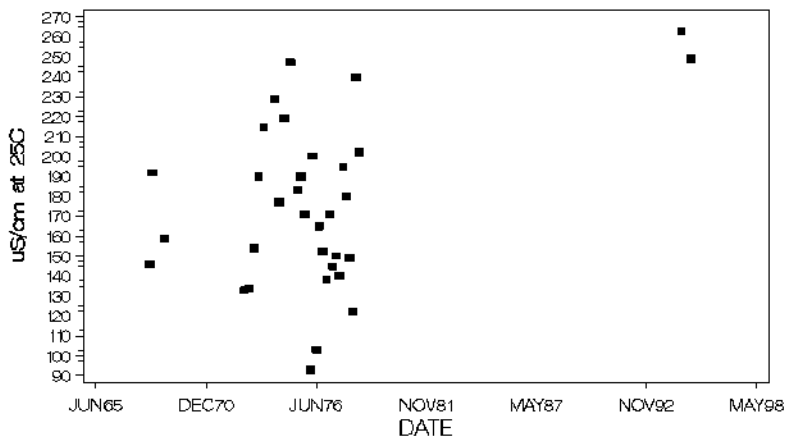

MAJOR IONS (% meq/l)

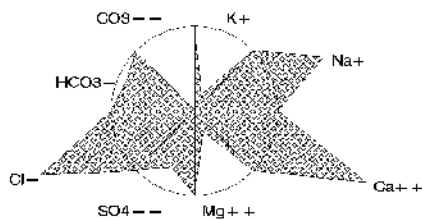

Chapman Lake, Hillsborough County

Chapman Lake Hillsborough County

USGS Quadrangle:	Sulphur Springs	Major Land Use/Land Cover (1990)
Section/Township/Range:	25-27S-18E	within 500 meters of the lakeshore:
Approx. Lake Center, Lat/Long:	280631/822728	- medium density residential (25%)
Surface Area:	19 acres	- low density residential (24%)
Approx. Lake Elevation:	55 feet	- freshwater marshes (10%)
Lake Type:	isolated (type 4)	
Major Basin:	Tampa Bay Drainage	
Minor Basin:	Chapman Lake Outlet	
Lake Region:	Land-o-Lakes	

Total Number of Samples Collected: 2 Most Recent Sample Collected: January 1997

Parameter	Units (Detection Limit)	Average Value	District Percentile	Florida Percentile
Chlorophyll a	ug/l (1)	12.6	70	42
Total Phosphorus	mg/l as P (0.01)	0.011	38	6
Total Nitrogen	mg/l as N (0.06)	2.31	90	85
Transparency (Secchi depth)	meters	1.62	53	78
Florida Trophic State Index		42	57	19
Specific Conductance	S/cm at 25C (1)	218	66	55
pH	standard units (0.1)	7.5	61	53
Color	PtCo units (1)	50	79	40
Turbidity	NTU (1)	2.1	53	21
Total Alkalinity	mg/l as CaCO3 (1)	41	72	57
Hardness	mg/l as CaCO3 (0.02)	57	59	
Total Suspended Solids	mg/l (0.05)	1.7	44	
Ammonia	mg/l as N (0.03)	0.015	60	
Nitrate+Nitrite	mg/l as N (0.01)	0.051	70	
Total Kjeldahl Nitrogen	mg/l as N (0.06)	2.26	95	
Orthophosphorus	mg/l as P (0.01)	0.011	64	
Chloride	mg/l (0.05)	31	87	
Sulfate	mg/l (0.05)	13	45	
Sodium	mg/l (0.06)	19.0	91	
Potassium	mg/l (0.07)	3.3	49	
Calcium	mg/l (0.04)	18.0	69	
Magnesium	mg/l (0.006)	2.9	43	
Iron	ug/l (0.03)	29	37	

Based upon the average FTSI of 42, water quality is considered good. Chapman Lake can be characterized as a colored, soft water, meso-eutrophic lake, with high concentrations of total nitrogen. The chemical type of water (predominant ionic composition) is calcium chloride.

Plots and Trends: No or insufficient data for plotting or trend detection. Shown is a diagram of the relative ionic composition of the lake water.

MAJOR IONS (% meq/l)

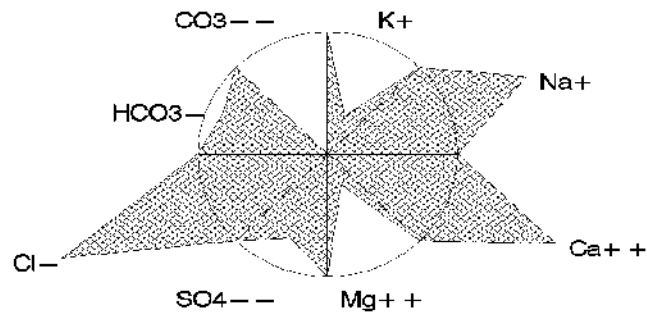

Chapman Lake, Hillsborough County

Church Lake Hillsborough County

USGS Quadrangle: Citrus Park Major Land Use/Land Cover (1990)
 Section/Township/Range: 28-27S-17E within 500 meters of the lakeshore:
 Approx. Lake Center, Lat/Long: 280611/823606 - medium density residential (24%)
 Surface Area: 68 acres - tree crops, typically citrus (18%)
 Approx. Lake Elevation: 36 feet - hardwood - conifer mixed (17%)
 Average Depth: 6.9 feet
 Observed Maximum Depth: 16.7 feet
 (reference elevation 35.7 feet)
 Lake Type: outflow (type 2)
 Major Basin: Tampa Bay Drainage
 Minor Basin: Unnamed Ditch
 Lake Region: Keystone Lakes

Total Number of Samples Collected: 2 Most Recent Sample Collected: January 1995

Parameter	Units (Detection Limit)	Average Value	District Percentile	Florida Percentile
Chlorophyll a	ug/l (1)	3.6	32	15
Total Phosphorus	mg/l as P (0.01)	0.010	33	5
Total Nitrogen	mg/l as N (0.06)	1.84	81	77
Transparency (Secchi depth)	meters	2.50	75	92
Florida Trophic State Index		36	44	11
Specific Conductance	S/cm at 25C (1)	187	54	50
pH	standard units (0.1)	6.9	29	28
Color	PtCo units (1)	8	24	8
Turbidity	NTU (1)	1.2	34	8
Total Alkalinity	mg/l as CaCO3 (1)	8	21	22
Hardness	mg/l as CaCO3 (0.02)	49	51	
Total Suspended Solids	mg/l (0.05)	1.3	35	
Ammonia	mg/l as N (0.03)	0.015	60	
Nitrate+Nitrite	mg/l as N (0.01)	0.005	33	
Total Kjeldahl Nitrogen	mg/l as N (0.06)	1.84	87	
Orthophosphorus	mg/l as P (0.01)	0.005	56	
Chloride	mg/l (0.05)	23	69	
Sulfate	mg/l (0.05)	35	85	
Sodium	mg/l (0.06)	10.5	62	
Potassium	mg/l (0.07)	4.3	59	
Calcium	mg/l (0.04)	11.0	43	
Magnesium	mg/l (0.006)	5.1	70	
Iron	ug/l (0.03)	28	35	

Based upon the average FTSI of 36, water quality is considered good. Church Lake can be characterized as a clear (color<=10 color units), soft water, mesotrophic lake, with high concentrations of total nitrogen. The chemical type of water (predominant ionic composition) is calcium sulfate.

Plots and Trends: The period of record for lake surface elevation extends back in time to the early 1930s. Lake elevations were greater during the brief period of data collection during the 1930s, than for the data collected from the late 1950s to the present. Specific conductivity was stable for the period of record (1965 to present). Also shown is a diagram of the relative ionic composition of the lake water.

MONTHLY AVERAGE SURFACE ELEVATION

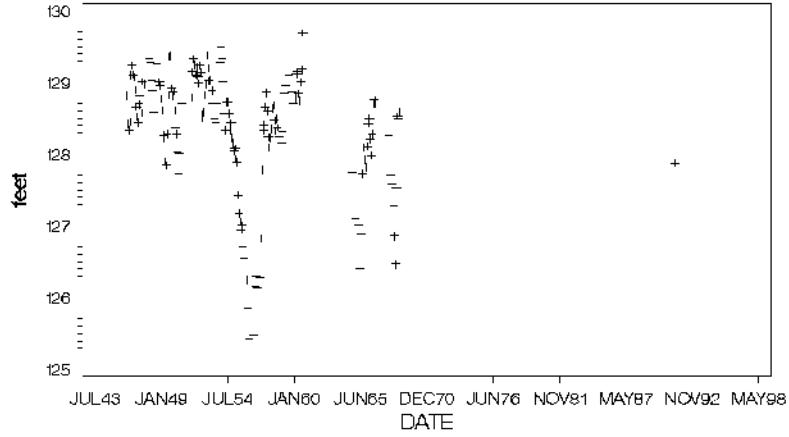

SPEC. CONDUCTANCE

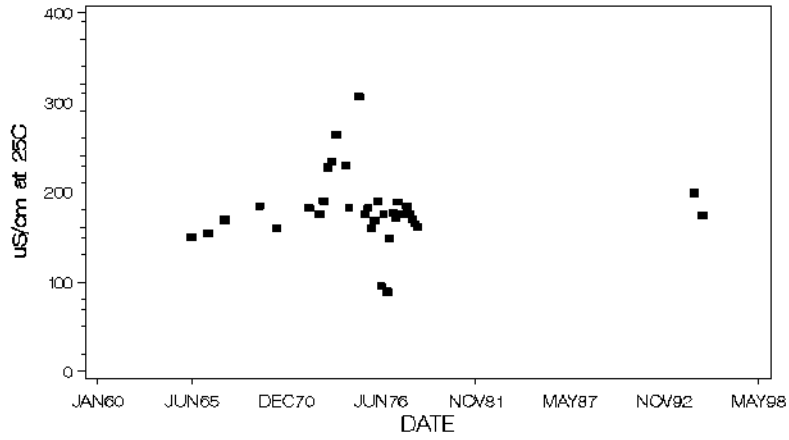

MAJOR IONS (% meq/l)

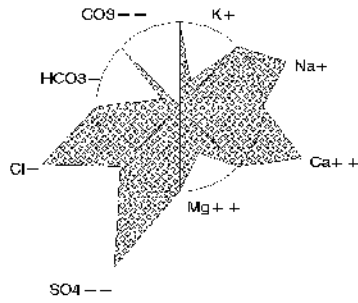

Church Lake, Hillsborough County

Crescent Lake Hillsborough County

USGS Quadrangle: Odessa Major Land Use/Land Cover (1990)
 Section/Township/Range: 10-27S-17E within 500 meters of the lakeshore:
 Approx. Lake Center, Lat/Long: 280931/823534 - medium density residential (24%)
 Surface Area: 46 acres - tree crops, typically citrus (18%)
 Approx. Lake Elevation: 43 feet - stream and lake swamps (13%)
 Average Depth: 8.2 feet
 (reference elevation 39 feet)
 Lake Type: inflow and outflow (type 3)
 Major Basin: Tampa Bay Drainage
 Minor Basin: Brooker Creek
 Lake Region: Keystone Lakes

Total Number of Samples Collected: 2 Most Recent Sample Collected: January 1996

Parameter	Units (Detection Limit)	Average Value	District Percentile	Florida Percentile
Chlorophyll a	ug/l (1)	5.6	46	23
Total Phosphorus	mg/l as P (0.01)	0.010	33	5
Total Nitrogen	mg/l as N (0.06)	0.91	33	30
Transparency (Secchi depth)	meters	2.40	74	91
Florida Trophic State Index		35	42	10
Specific Conductance	S/cm at 25C (1)	148	37	41
pH	standard units (0.1)	5.8	<5	6
Color	PtCo units (1)	70	84	60
Turbidity	NTU (1)	0.5	28	<5
Total Alkalinity	mg/l as CaCO3 (1)	2	<5	5
Hardness	mg/l as CaCO3 (0.02)	40	36	
Total Suspended Solids	mg/l (0.05)	1.2	33	
Ammonia	mg/l as N (0.03)	0.056	79	
Nitrate+Nitrite	mg/l as N (0.01)	0.023	56	
Total Kjeldahl Nitrogen	mg/l as N (0.06)	0.89	38	
Orthophosphorus	mg/l as P (0.01)	0.005	56	
Chloride	mg/l (0.05)	17	41	
Sulfate	mg/l (0.05)	32	81	
Sodium	mg/l (0.06)	7.5	39	
Potassium	mg/l (0.07)	5.0	66	
Calcium	mg/l (0.04)	8.7	32	
Magnesium	mg/l (0.006)	4.4	61	
Iron	ug/l (0.03)	55	64	

Based upon the average FTSI of 35, water quality is considered good. Crescent Lake can be characterized as a colored, soft water, meso-eutrophic lake. The chemical type of water (predominant ionic composition) is calcium sulfate.

Also of note:

- The measured pH was low.

Plots and Trends: Lake surface elevation and conductivity have been stable over the period of record. Also shown is a diagram of the relative ionic composition of the lake water.

MONTHLY AVERAGE SURFACE ELEVATION

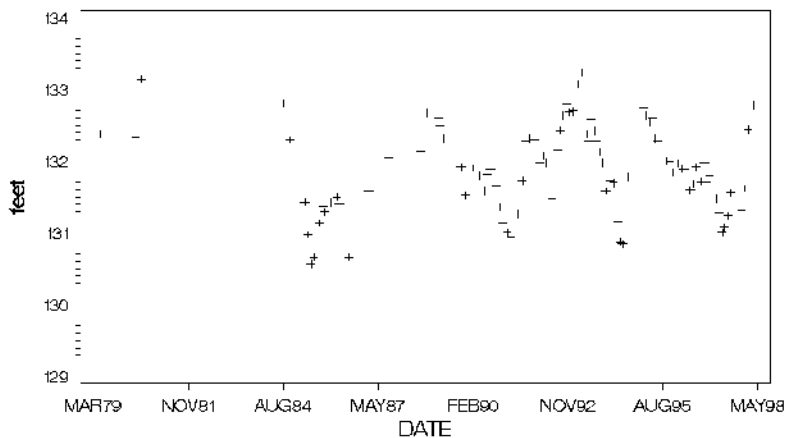

SPEC. CONDUCTANCE

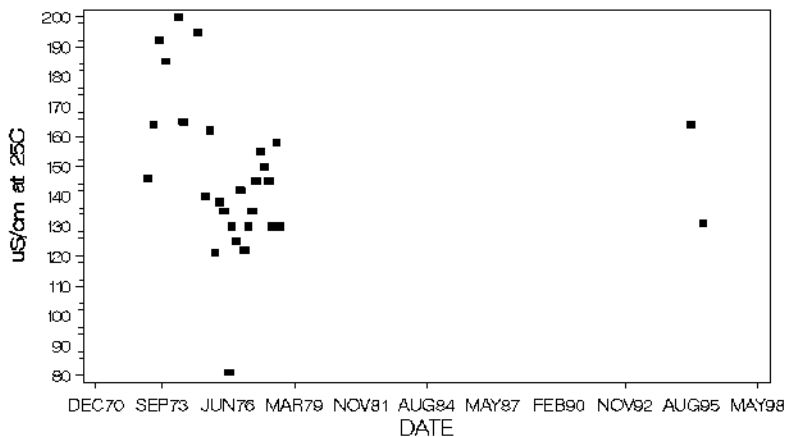

MAJOR IONS (% meq/l)

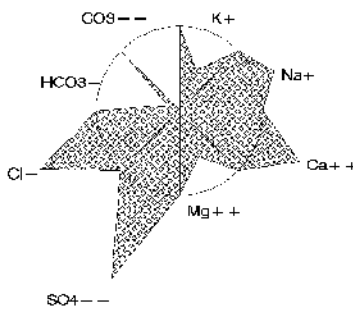

Crescent Lake, Hillsborough County

Lake Cypress Hillsborough County

USGS Quadrangle:	Odessa	Major Land Use/Land Cover (1990)
Section/Township/Range:	24-27S-17E	within 500 meters of the lakeshore:
Approx. Lake Center, Lat/Long:	280731/823356	- shrub and brushland range (22%)
Surface Area:	17 acres	- other open lands - rural (14%)
Approx. Lake Elevation:	49 feet	- medium density residential (13%)
Average Depth: 9.8 feet		
Observed Maximum Depth: 19.9 feet		
(reference elevation 48.9 feet)		
Lake Type: inflow and outflow (type 3)		
Major Basin: Tampa Bay Drainage		
Minor Basin: Upper Rocky Creek		
Lake Region: Tampa Plain		

Total Number of Samples Collected: 4 Most Recent Sample Collected: February 1997

Parameter	Units (Detection Limit)	Average Value	District Percentile	Florida Percentile
Chlorophyll a	ug/l (1)	2.9	23	12
Total Phosphorus	mg/l as P (0.01)	0.008	31	<5
Total Nitrogen	mg/l as N (0.06)	0.64	14	17
Transparency (Secchi depth)	meters	3.27	88	>95
Florida Trophic State Index		26	16	<5
Specific Conductance	S/cm at 25C (1)	210	64	54
pH	standard units (0.1)	6.1	6	9
Color	PtCo units (1)	69	84	59
Turbidity	NTU (1)	1.2	34	8
Total Alkalinity	mg/l as CaCO3 (1)	3	7	8
Hardness	mg/l as CaCO3 (0.02)	30	21	
Total Suspended Solids	mg/l (0.05)	1.1	31	
Ammonia	mg/l as N (0.03)	0.015	60	
Nitrate+Nitrite	mg/l as N (0.01)	0.005	33	
Total Kjeldahl Nitrogen	mg/l as N (0.06)	0.64	19	
Orthophosphorus	mg/l as P (0.01)	0.005	56	
Chloride	mg/l (0.05)	42	>95	
Sulfate	mg/l (0.05)	25	71	
Sodium	mg/l (0.06)	25.5	>95	
Potassium	mg/l (0.07)	1.9	32	
Calcium	mg/l (0.04)	6.3	21	
Magnesium	mg/l (0.006)	3.5	52	
Iron	ug/l (0.03)	46	58	

Based upon the average FTSI of 26, water quality is considered good. Lake Cypress can be characterized as a colored, soft water, oligo-mesotrophic lake, with low concentrations of total phosphorus and low concentrations of total nitrogen. The chemical type of water (predominant ionic composition) is sodium chloride.

Plots and Trends: No or insufficient data for plotting or trend detection. Shown is a diagram of the relative ionic composition of the lake water.

MAJOR IONS (% meq/l)

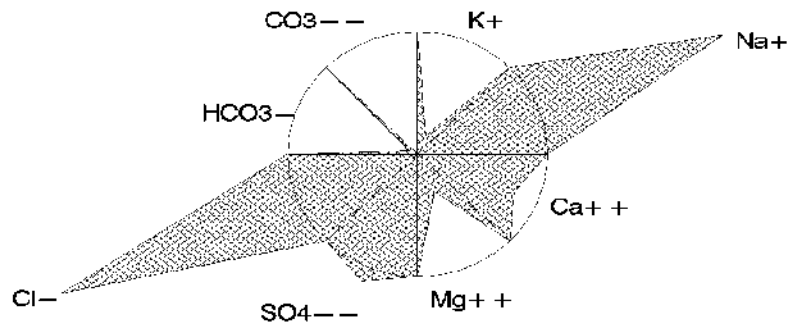

Lake Cypress, Hillsborough County

Deer Lake Hillsborough County

USGS Quadrangle:	Lutz	Major Land Use/Land Cover (1990)
Section/Township/Range:	1-27S-18E	within 500 meters of the lakeshore:
Approx. Lake Center, Lat/Long:	281003/822747	- medium density residential (35%)
Surface Area:	35 acres	- cropland and pastureland (23%)
Approx. Lake Elevation:	67 feet	- other open lands - rural (9%)
Average Depth: 8.3 feet		
Observed Maximum Depth: 19.5 feet		
(reference elevation 66.5 feet)		
Lake Type: outflow (type 2)		
Major Basin: Tampa Bay Drainage		
Minor Basin: Drainage Canal		
Lake Region: Land-o-Lakes		

Total Number of Samples Collected: 2 Most Recent Sample Collected: January 1995

Parameter	Units (Detection Limit)	Average Value	District Percentile	Florida Percentile
Chlorophyll a	ug/l (1)	6.0	50	26
Total Phosphorus	mg/l as P (0.01)	0.005	31	<5
Total Nitrogen	mg/l as N (0.06)	0.71	18	21
Transparency (Secchi depth)	meters	1.95	62	84
Florida Trophic State Index		32	34	7
Specific Conductance	S/cm at 25C (1)	197	58	51
pH	standard units (0.1)	6.9	29	28
Color	PtCo units (1)	18	51	15
Turbidity	NTU (1)	2.5	58	26
Total Alkalinity	mg/l as CaCO3 (1)	9	24	24
Hardness	mg/l as CaCO3 (0.02)	41	38	
Total Suspended Solids	mg/l (0.05)	1.9	49	
Ammonia	mg/l as N (0.03)	0.015	60	
Nitrate+Nitrite	mg/l as N (0.01)	0.058	72	
Total Kjeldahl Nitrogen	mg/l as N (0.06)	0.65	20	
Orthophosphorus	mg/l as P (0.01)	0.005	56	
Chloride	mg/l (0.05)	27	80	
Sulfate	mg/l (0.05)	32	81	
Sodium	mg/l (0.06)	17.5	89	
Potassium	mg/l (0.07)	3.4	49	
Calcium	mg/l (0.04)	11.0	43	
Magnesium	mg/l (0.006)	3.1	47	
Iron	ug/l (0.03)	23	28	

Based upon the average FTSI of 32, water quality is considered good. Deer Lake can be characterized as a clear to moderately colored (10<color<20 color units), soft water, meso-eutrophic lake, with low concentrations of total phosphorus, low concentrations of total nitrogen. The chemical type of water (predominant ionic composition) is sodium chloride.

Plots and Trends: The large dip in the lake surface elevation in the mid-1990s is typical of many lakes in the Northwest Hillsborough region. Over 50 percent of the lakes sampled in the area had the lowest elevations for their individual periods of record in 1994. Lake levels have since recovered from the drought period. Also shown is a diagram of the relative ionic composition of the lake water.

MONTHLY AVERAGE SURFACE ELEVATION

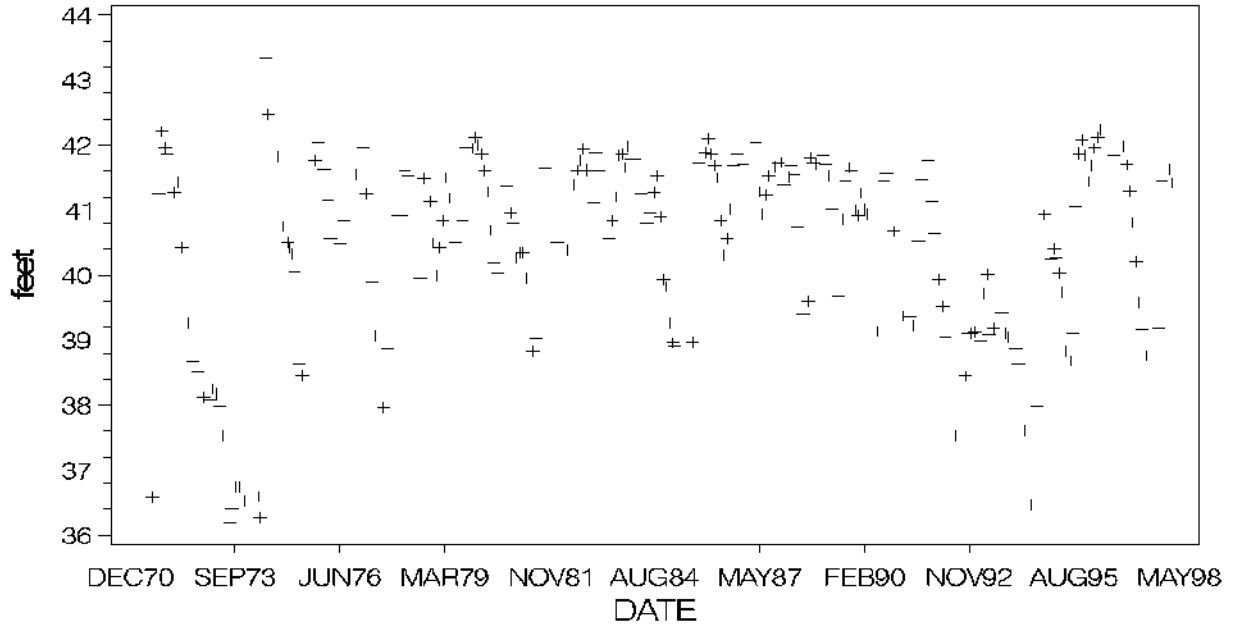

MAJOR IONS (% meq/l)

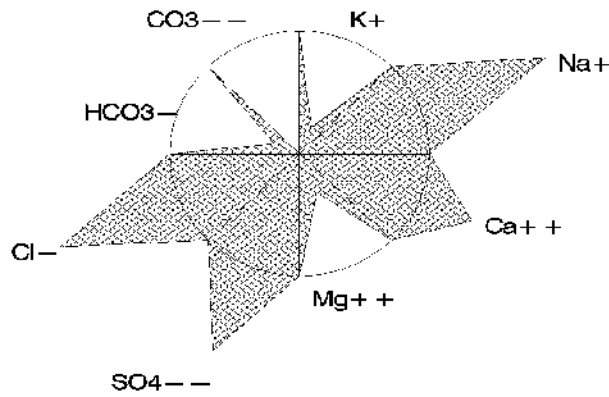

Dosson Lake Hillsborough County

USGS Quadrangle:	Citrus Park	Major Land Use/Land Cover (1990)
Section/Township/Range:	20-27S-18E	within 500 meters of the lakeshore:
Approx. Lake Center, Lat/Long:	280723/823132	- cropland and pastureland (32%)
Surface Area:	11 acres	- low density residential (24%)
Approx. Lake Elevation:	54 feet	- cypress (17%)
Average Depth: 6.4 feet		
Observed Maximum Depth: 17.4 feet		
(reference elevation 53.4 feet)		
Lake Type: inflow and outflow (type 3)		
Major Basin: Tampa Bay Drainage		
Minor Basin: Brushy Creek		
Lake Region: Tampa Plain		

Total Number of Samples Collected: 8 Most Recent Sample Collected: May 1997

Parameter	Units (Detection Limit)	Average Value	District Percentile	Florida Percentile
Chlorophyll a	ug/l (1)	15.4	74	46
Total Phosphorus	mg/l as P (0.01)	0.020	65	10
Total Nitrogen	mg/l as N (0.06)	0.95	37	32
Transparency (Secchi depth)	meters	0.97	32	62
Florida Trophic State Index		48	70	30
Specific Conductance	S/cm at 25C (1)	92	11	20
pH	standard units (0.1)	6.4	12	15
Color	PtCo units (1)	142	93	89
Turbidity	NTU (1)	3.7	68	39
Total Alkalinity	mg/l as CaCO3 (1)	7	18	20
Hardness	mg/l as CaCO3 (0.02)	14	5	
Total Suspended Solids	mg/l (0.05)	1.5	39	
Ammonia	mg/l as N (0.03)	0.065	81	
Nitrate+Nitrite	mg/l as N (0.01)	0.014	42	
Total Kjeldahl Nitrogen	mg/l as N (0.06)	0.94	42	
Orthophosphorus	mg/l as P (0.01)	0.008	56	
Chloride	mg/l (0.05)	12	23	
Sulfate	mg/l (0.05)	3	14	
Sodium	mg/l (0.06)	7.8	42	
Potassium	mg/l (0.07)	1.3	22	
Calcium	mg/l (0.04)	3.9	8	
Magnesium	mg/l (0.006)	1.0	6	
Iron	ug/l (0.03)	86	79	

Based upon the average FTSI of 48, water quality is considered good. Dosson Lake can be characterized as a highly colored, soft water, meso-eutrophic lake. The chemical type of water (predominant ionic composition) is sodium chloride.

Plots and Trends: The large dip in the lake surface elevation in the mid-1990s is typical of many lakes in the Northwest Hillsborough region. Nearly two-thirds of the lakes sampled in the area had the lowest elevations for their individual periods of record between 1991 and 1995. Lake Dosson lake levels have since recovered from the drought period. There is no trend in the available specific conductance data. Also shown is a diagram of the relative ionic composition of the lake water.

MONTHLY AVERAGE SURFACE ELEVATION

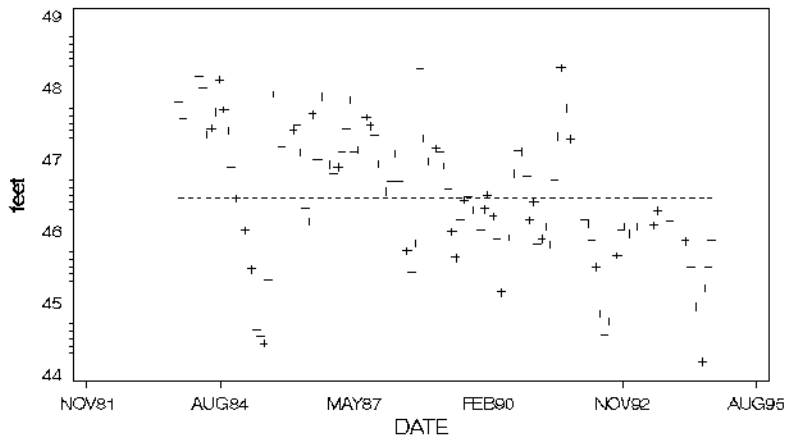

SPEC. CONDUCTANCE

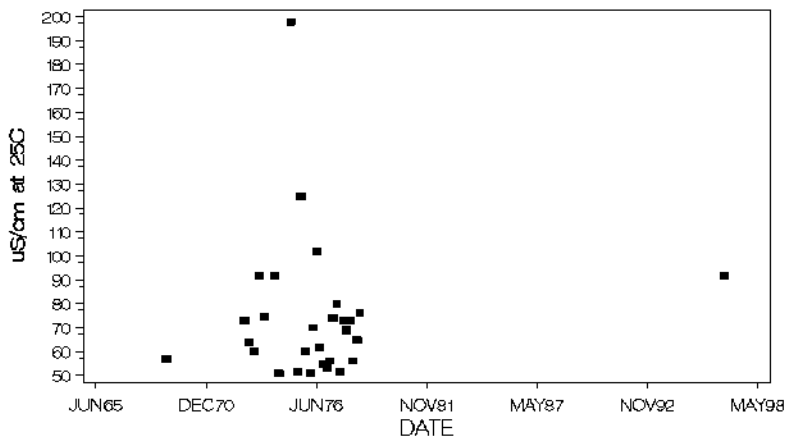

MAJOR IONS (% meq/l)

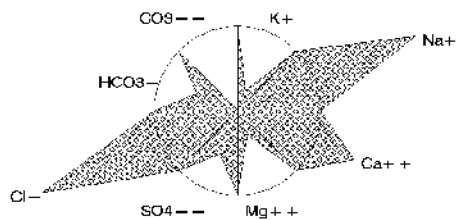

Dosson Lake, Hillsborough County

Lake Eckles

Hillsborough County

USGS Quadrangle: Sulphur Springs Major Land Use/Land Cover (1990)
 Section/Township/Range: 14-28S-18E within 500 meters of the lakeshore:
 Approx. Lake Center, Lat/Long: 280321/822817 - high density residential (57%)
 Surface Area: 25 acres - medium density residential (22%)
 Approx. Lake Elevation: 33 feet - recreational (11%)
 Lake Type: isolated (type 4)
 Major Basin: Hillsborough River
 Minor Basin: Curiosity Creek
 Lake Region: Land-o-Lakes

Total Number of Samples Collected: 2 Most Recent Sample Collected: February 1997

Parameter	Units (Detection Limit)	Average Value	District Percentile	Florida Percentile
Chlorophyll a	ug/l (1)	7.9	57	33
Total Phosphorus	mg/l as P (0.01)	0.011	38	6
Total Nitrogen	mg/l as N (0.06)	1.03	42	34
Transparency (Secchi depth)	meters	0.90	28	60
Florida Trophic State Index		46	66	27
Specific Conductance	S/cm at 25C (1)	213	64	54
pH	standard units (0.1)	7.2	43	40
Color	PtCo units (1)	13	41	12
Turbidity	NTU (1)	3.8	69	40
Total Alkalinity	mg/l as CaCO3 (1)	40	71	56
Hardness	mg/l as CaCO3 (0.02)	58	60	
Total Suspended Solids	mg/l (0.05)	1.9	49	
Ammonia	mg/l as N (0.03)	0.030	61	
Nitrate+Nitrite	mg/l as N (0.01)	0.068	77	
Total Kjeldahl Nitrogen	mg/l as N (0.06)	0.96	44	
Orthophosphorus	mg/l as P (0.01)	0.005	56	
Chloride	mg/l (0.05)	30	85	
Sulfate	mg/l (0.05)	13	45	
Sodium	mg/l (0.06)	17.5	89	
Potassium	mg/l (0.07)	1.8	30	
Calcium	mg/l (0.04)	21.0	78	
Magnesium	mg/l (0.006)	1.5	16	
Iron	ug/l (0.03)	24	29	

Based upon the average FTSI of 46, water quality is considered good. Lake Eckles can be characterized as a clear to moderately colored (10<color<20 color units), soft water, meso-eutrophic lake. The chemical type of water (predominant ionic composition) is calcium chloride.

Plots and Trends: No or insufficient data for plotting or trend detection. Shown is a diagram of the relative ionic composition of the lake water.

MAJOR IONS (% meq/l)

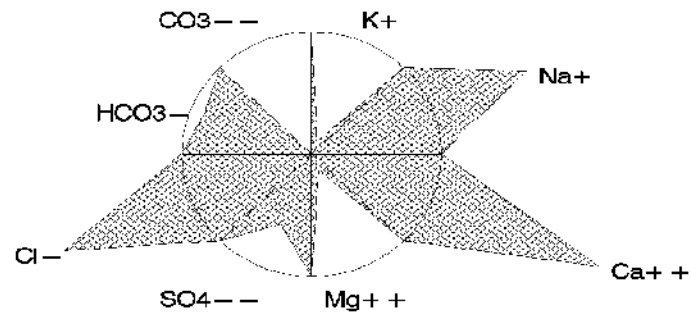

Egypt Lake Hillsborough County

USGS Quadrangle: Sulphur Springs Major Land Use/Land Cover (1990)
 Section/Township/Range: 27-28S-18E within 500 meters of the lakeshore:
 Approx. Lake Center, Lat/Long: 280040/822933 - high density residential (79%)
 Surface Area: 67 acres - institutional (5%)
 Approx. Lake Elevation: 38 feet - commercial and services (5%)
 Average Depth: 16.4 feet
 (reference elevation 37 feet)
 Lake Type: outflow (type 2)
 Major Basin: Tampa Bay Drainage
 Minor Basin: Sweetwater Creek
 Lake Region: Land-o-Lakes

Total Number of Samples Collected: 2 Most Recent Sample Collected: January 1995

Parameter	Units (Detection Limit)	Average Value	District Percentile	Florida Percentile
Chlorophyll a	ug/l (1)	5.5	46	23
Total Phosphorus	mg/l as P (0.01)	0.061	89	46
Total Nitrogen	mg/l as N (0.06)	1.30	61	45
Transparency (Secchi depth)	meters	1.55	51	77
Florida Trophic State Index		46	66	27
Specific Conductance	S/cm at 25C (1)	233	73	57
pH	standard units (0.1)	7.7	69	60
Color	PtCo units (1)	8	24	8
Turbidity	NTU (1)	2.8	61	30
Total Alkalinity	mg/l as CaCO3 (1)	52	81	63
Hardness	mg/l as CaCO3 (0.02)	84	83	
Total Suspended Solids	mg/l (0.05)	2.8	62	
Ammonia	mg/l as N (0.03)	0.159	94	
Nitrate+Nitrite	mg/l as N (0.01)	0.005	33	
Total Kjeldahl Nitrogen	mg/l as N (0.06)	1.29	68	
Orthophosphorus	mg/l as P (0.01)	0.009	56	
Chloride	mg/l (0.05)	18	46	
Sulfate	mg/l (0.05)	23	67	
Sodium	mg/l (0.06)	10.3	60	
Potassium	mg/l (0.07)	2.4	39	
Calcium	mg/l (0.04)	30.0	93	
Magnesium	mg/l (0.006)	2.2	31	
Iron	ug/l (0.03)	17	13	

Based upon the average FTSI of 46, water quality is considered good. Egypt Lake can be characterized as a clear (color<=10 color units), medium hard water, meso-eutrophic lake, with a high concentrations of total phosphorus. The chemical type of water (predominant ionic composition) is calcium bicarbonate (1 sample) or calcium chloride (1 sample).

Plots and Trends: The plot of lake surface elevation shows that lake levels in Egypt Lake were generally about one foot greater during the 1980s than during the 1990s. Also shown is a diagram of the relative ionic composition of the lake water.

MONTHLY AVERAGE SURFACE ELEVATION

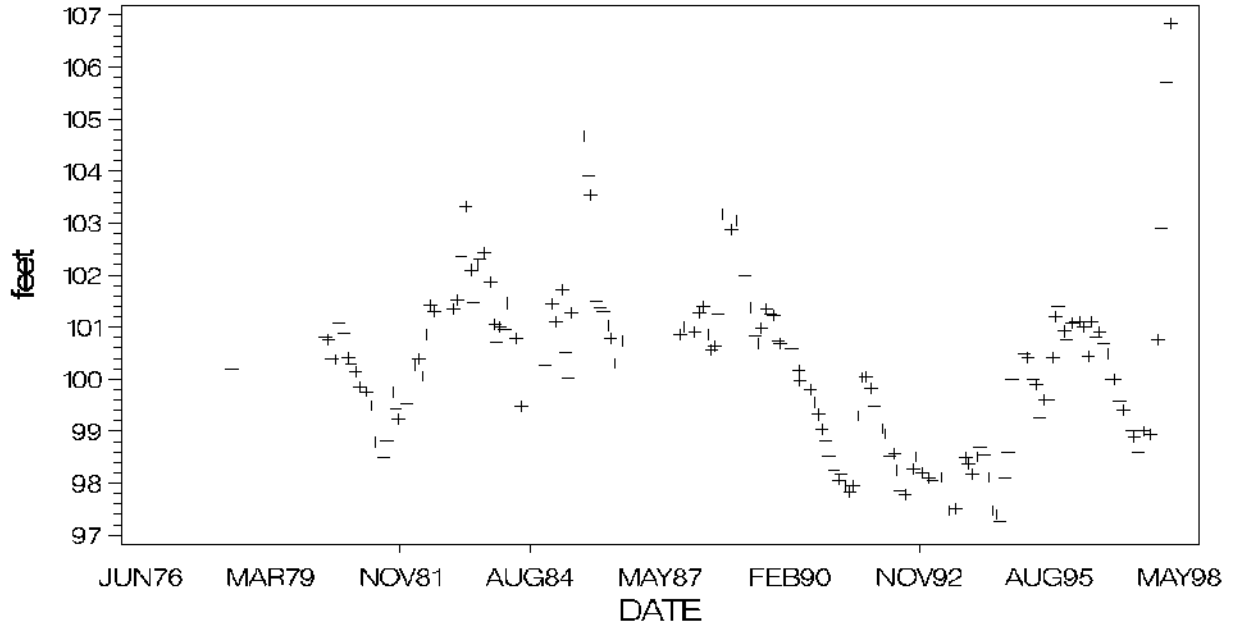

MAJOR IONS (% meq/l)

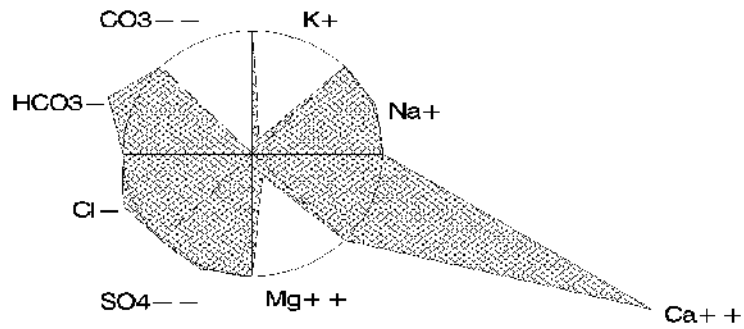

Lake Ellen

Hillsborough County

USGS Quadrangle: Sulphur Springs Major Land Use/Land Cover (1990)
 Section/Township/Range: 10-28S-18E within 500 meters of the lakeshore:
 Approx. Lake Center, Lat/Long: 280340/822949 - high density residential (40%)
 Surface Area: 53 acres - medium density residential (34%)
 Approx. Lake Elevation: 42 feet - commercial and services (10%)
 Lake Type: inflow and outflow (type 3)
 Major Basin: Tampa Bay Drainage
 Minor Basin: Sweetwater Creek
 Lake Region: Land-o-Lakes

Total Number of Samples Collected: 2 Most Recent Sample Collected: February 1997

Parameter	Units (Detection Limit)	Average Value	District Percentile	Florida Percentile
Chlorophyll a	ug/l (1)	7.8	57	32
Total Phosphorus	mg/l as P (0.01)	0.010	33	5
Total Nitrogen	mg/l as N (0.06)	1.01	41	34
Transparency (Secchi depth)	meters	1.92	62	84
Florida Trophic State Index		37	46	12
Specific Conductance	S/cm at 25C (1)	192	56	51
pH	standard units (0.1)	7.3	50	45
Color	PtCo units (1)	15	46	13
Turbidity	NTU (1)	1.3	36	10
Total Alkalinity	mg/l as CaCO3 (1)	40	71	56
Hardness	mg/l as CaCO3 (0.02)	61	63	
Total Suspended Solids	mg/l (0.05)	1.0	28	
Ammonia	mg/l as N (0.03)	0.015	60	
Nitrate+Nitrite	mg/l as N (0.01)	0.062	74	
Total Kjeldahl Nitrogen	mg/l as N (0.06)	0.95	43	
Orthophosphorus	mg/l as P (0.01)	0.005	56	
Chloride	mg/l (0.05)	23	69	
Sulfate	mg/l (0.05)	12	41	
Sodium	mg/l (0.06)	12.5	73	
Potassium	mg/l (0.07)	2.4	39	
Calcium	mg/l (0.04)	21.0	78	
Magnesium	mg/l (0.006)	2.0	25	
Iron	ug/l (0.03)	22	25	

Based upon the average FTSI of 37, water quality is considered good. Lake Ellen can be characterized as a clear to moderately colored (10 < color < 20 color units), medium hard water, meso-eutrophic lake. The chemical type of water (predominant ionic composition) is calcium chloride.

Plots and Trends: Lake surface elevations have been stable in Lake Ellen for the period of record. The range in fluctuation is between 5 and 6 feet over the period of record. Also shown is a diagram of the relative ionic composition of the lake water.

MONTHLY AVERAGE SURFACE ELEVATION

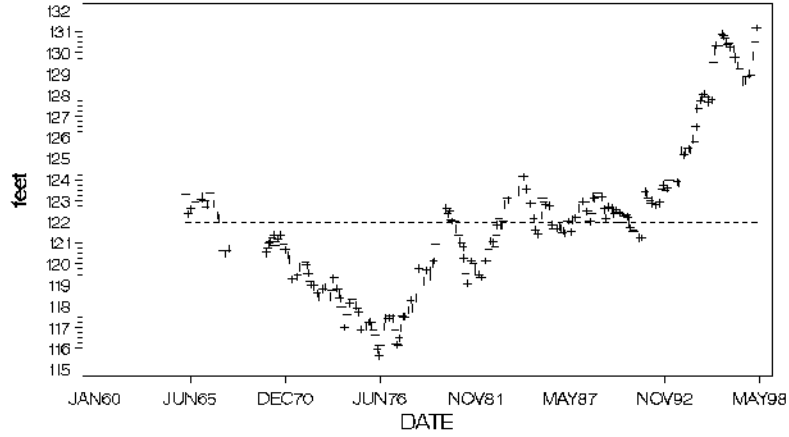

SPEC. CONDUCTANCE

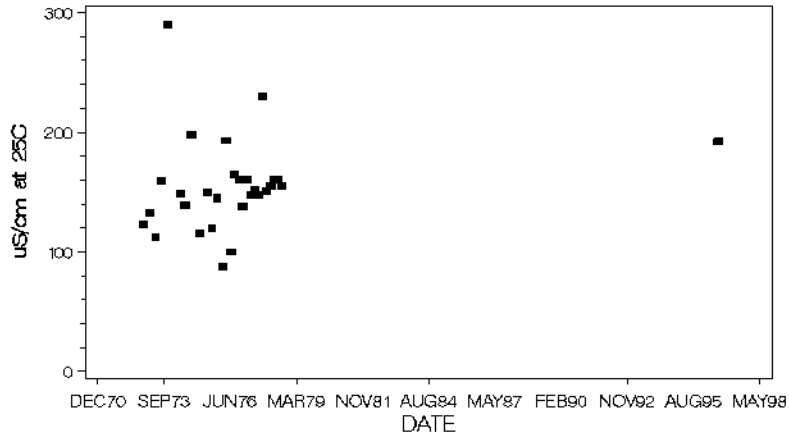

MAJOR IONS (% meq/l)

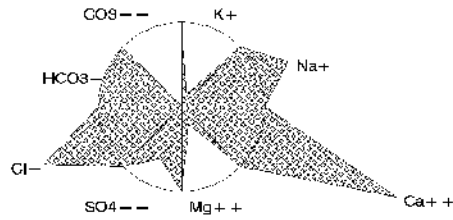

Lake Ellen, Hillsborough County

Lake Ellen

Hillsborough County

USGS Quadrangle: Sulphur Springs Major Land Use/Land Cover (1990)
 Section/Township/Range: 25-27S-18E within 500 meters of the lakeshore:
 Approx. Lake Center, Lat/Long: 280600/822724 - low density residential (34%)
 Surface Area: 7 acres - hardwood - conifer mixed (21%)
 Approx. Lake Elevation: 47 feet - medium density residential (14%)
 Lake Type: isolated (type 4)
 Major Basin: Tampa Bay Drainage
 Minor Basin: Chapman Lake Outlet
 Lake Region: Land-o-Lakes

Total Number of Samples Collected: 2 Most Recent Sample Collected: March 1997

Parameter	Units (Detection Limit)	Average Value	District Percentile	Florida Percentile
Chlorophyll a	ug/l (1)	18.9	79	51
Total Phosphorus	mg/l as P (0.01)	0.012	41	6
Total Nitrogen	mg/l as N (0.06)	1.43	68	53
Transparency (Secchi depth)	meters	1.77	57	81
Florida Trophic State Index		43	59	21
Specific Conductance	S/cm at 25C (1)	233	73	57
pH	standard units (0.1)	7.1	38	35
Color	PtCo units (1)	30	67	23
Turbidity	NTU (1)	1.8	47	17
Total Alkalinity	mg/l as CaCO3 (1)	55	83	65
Hardness	mg/l as CaCO3 (0.02)	86	85	
Total Suspended Solids	mg/l (0.05)	1.7	44	
Ammonia	mg/l as N (0.03)	0.015	60	
Nitrate+Nitrite	mg/l as N (0.01)	0.063	74	
Total Kjeldahl Nitrogen	mg/l as N (0.06)	1.37	72	
Orthophosphorus	mg/l as P (0.01)	0.005	56	
Chloride	mg/l (0.05)	16	37	
Sulfate	mg/l (0.05)	31	79	
Sodium	mg/l (0.06)	8.6	49	
Potassium	mg/l (0.07)	5.3	68	
Calcium	mg/l (0.04)	28.0	90	
Magnesium	mg/l (0.006)	3.8	56	
Iron	ug/l (0.03)	21	22	

Based upon the average FTSI of 43, water quality is considered good. Lake Ellen can be characterized as a moderately colored, medium hard water, eutrophic lake. The chemical type of water (predominant ionic composition) is calcium sulfate.

Plots and Trends: No or insufficient data available for plotting or trend detection. Shown is a diagram of the relative ionic composition of the lake water.

MAJOR IONS (% meq/l)

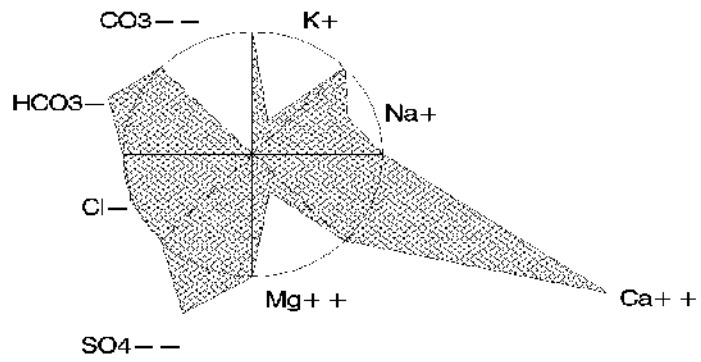

Lake Ellen

Hillsborough County

USGS Quadrangle: Citrus Park Major Land Use/Land Cover (1990)
 Section/Township/Range: 19-27S-18E within 500 meters of the lakeshore:
 Approx. Lake Center, Lat/Long: 280716/823208 - low density residential (45%)
 Surface Area: 5 acres - cropland and pastureland (22%)
 Approx. Lake Elevation: 53 feet - medium density residential (13%)
 Average Depth: 8.8 feet
 Observed Maximum Depth: 14 feet
 (reference elevation 53 feet)
 Lake Type: inflow and outflow (type 3)
 Major Basin: Tampa Bay Drainage
 Minor Basin: Upper Rocky Creek
 Lake Region: Keystone Lakes

Total Number of Samples Collected: 2 Most Recent Sample Collected: January 1997

Parameter	Units (Detection Limit)	Average Value	District Percentile	Florida Percentile
Chlorophyll a	ug/l (1)	3.6	32	15
Total Phosphorus	mg/l as P (0.01)	0.022	68	12
Total Nitrogen	mg/l as N (0.06)	0.57	7	14
Transparency (Secchi depth)	meters	2.73	79	94
Florida Trophic State Index		32	34	7
Specific Conductance	S/cm at 25C (1)	297	88	69
pH	standard units (0.1)	6.8	25	25
Color	PtCo units (1)	25	62	20
Turbidity	NTU (1)	0.8	28	<5
Total Alkalinity	mg/l as CaCO3 (1)	29	57	48
Hardness	mg/l as CaCO3 (0.02)	49	51	
Total Suspended Solids	mg/l (0.05)	0.5	11	
Ammonia	mg/l as N (0.03)	0.015	60	
Nitrate+Nitrite	mg/l as N (0.01)	0.010	34	
Total Kjeldahl Nitrogen	mg/l as N (0.06)	0.56	12	
Orthophosphorus	mg/l as P (0.01)	0.008	56	
Chloride	mg/l (0.05)	65	>95	
Sulfate	mg/l (0.05)	11	39	
Sodium	mg/l (0.06)	36.0	>95	
Potassium	mg/l (0.07)	1.8	30	
Calcium	mg/l (0.04)	16.0	62	
Magnesium	mg/l (0.006)	2.3	33	
Iron	ug/l (0.03)	31	40	

Based upon the average FTSI of 32, water quality is considered good. Lake Ellen can be characterized as a moderately colored, soft water, oligo-mesotrophic lake, with very low concentrations of total nitrogen. The chemical type of water (predominant ionic composition) is sodium chloride.

Plots and Trends: No or insufficient data available for plotting or trend detection. Shown is a diagram of the relative ionic composition of the lake water.

MAJOR IONS (% meq/l)

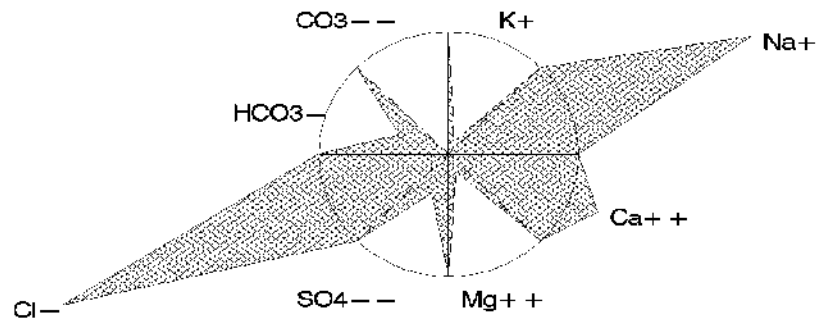

Lake Ellen, Hillsborough County

Lake Estes

Hillsborough County

USGS Quadrangle: Sulphur Springs Major Land Use/Land Cover (1990)
 Section/Township/Range: 24-27S-18E within 500 meters of the lakeshore:
 Approx. Lake Center, Lat/Long: 280710/822758 - medium density residential (42%)
 Surface Area: 14 acres - other open lands - rural (13%)
 Approx. Lake Elevation: 58 feet - commercial and services (9%)
 Lake Type: isolated (type 4)
 Major Basin: Tampa Bay Drainage
 Minor Basin: Chapman Lake Outlet
 Lake Region: Land-o-Lakes

Total Number of Samples Collected: 2 Most Recent Sample Collected: January 1997

Parameter	Units (Detection Limit)	Average Value	District Percentile	Florida Percentile
Chlorophyll a	ug/l (1)	4.8	43	19
Total Phosphorus	mg/l as P (0.01)	0.012	41	6
Total Nitrogen	mg/l as N (0.06)	0.69	16	20
Transparency (Secchi depth)	meters	1.56	51	77
Florida Trophic State Index		39	51	14
Specific Conductance	S/cm at 25C (1)	270	84	64
pH	standard units (0.1)	7.5	61	53
Color	PtCo units (1)	35	70	27
Turbidity	NTU (1)	1.2	34	8
Total Alkalinity	mg/l as CaCO3 (1)	56	84	66
Hardness	mg/l as CaCO3 (0.02)	78	78	
Total Suspended Solids	mg/l (0.05)	1.5	39	
Ammonia	mg/l as N (0.03)	0.015	60	
Nitrate+Nitrite	mg/l as N (0.01)	0.012	40	
Total Kjeldahl Nitrogen	mg/l as N (0.06)	0.68	22	
Orthophosphorus	mg/l as P (0.01)	0.008	56	
Chloride	mg/l (0.05)	37	94	
Sulfate	mg/l (0.05)	20	61	
Sodium	mg/l (0.06)	23.0	95	
Potassium	mg/l (0.07)	1.7	28	
Calcium	mg/l (0.04)	26.5	88	
Magnesium	mg/l (0.006)	2.9	43	
Iron	ug/l (0.03)	27	33	

Based upon the average FTSI of 39, water quality is considered good. Lake Estes can be characterized as a moderately colored, medium hard water, oligo-mesotrophic lake, with low concentrations of total nitrogen. The chemical type of water (predominant ionic composition) is calcium chloride.

Also of note:

- Cattails dominate more than 30% of the lake shoreline.

Plots and Trends: No or insufficient data available for plotting or trend detection. Shown is a diagram of the relative ionic composition of the lake water.

MAJOR IONS (% meq/l)

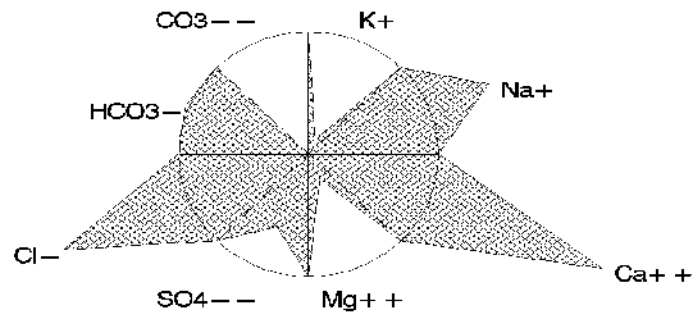

Lake Estes, Hillsborough County

Lake Eva

Hillsborough County

USGS Quadrangle: Citrus Park Major Land Use/Land Cover (1990)
 Section/Township/Range: 22-27S-17E within 500 meters of the lakeshore:
 Approx. Lake Center, Lat/Long: 280708/823535 - medium density residential (72%)
 Surface Area: 6 acres - cropland and pastureland (11%)
 Approx. Lake Elevation: 38 feet - wetland forested mixed (7%)
 Lake Type: isolated (type 4)
 Major Basin: Tampa Bay Drainage
 Minor Basin: Upper Brooker Creek
 Lake Region: Keystone Lakes

Total Number of Samples Collected: 2 Most Recent Sample Collected: January 1996

Parameter	Units (Detection Limit)	Average Value	District Percentile	Florida Percentile
Chlorophyll a	ug/l (1)	11.9	70	41
Total Phosphorus	mg/l as P (0.01)	0.015	53	8
Total Nitrogen	mg/l as N (0.06)	0.32	<5	<5
Transparency (Secchi depth)	meters	2.72	79	94
Florida Trophic State Index		31	31	6
Specific Conductance	S/cm at 25C (1)	962	>95	92
pH	standard units (0.1)	6.3	10	13
Color	PtCo units (1)	5	9	5
Turbidity	NTU (1)	6.0	77	55
Total Alkalinity	mg/l as CaCO3 (1)	8	21	22
Hardness	mg/l as CaCO3 (0.02)	18	8	
Total Suspended Solids	mg/l (0.05)	1.8	47	
Ammonia	mg/l as N (0.03)	0.063	81	
Nitrate+Nitrite	mg/l as N (0.01)	0.005	33	
Total Kjeldahl Nitrogen	mg/l as N (0.06)	0.30	<5	
Orthophosphorus	mg/l as P (0.01)	0.012	68	
Chloride	mg/l (0.05)	13	27	
Sulfate	mg/l (0.05)	15	50	
Sodium	mg/l (0.06)	9.1	53	
Potassium	mg/l (0.07)	0.9	17	
Calcium	mg/l (0.04)	4.5	11	
Magnesium	mg/l (0.006)	1.6	18	
Iron	ug/l (0.03)	73	72	

Based upon the average FTSI of 31, water quality is considered good. Lake Eva can be characterized as a clear (color<=10 color units), soft water, meso-eutrophic lake, with very low concentrations of total nitrogen. The chemical type of water (predominant ionic composition) is sodium chloride.

Also of note:

- Melaleuca was observed on the lake shore.

Plots and Trends: No or insufficient data available for plotting or trend detection. Shown is a diagram of the relative ionic composition of the lake water.

MAJOR IONS (% meq/l)

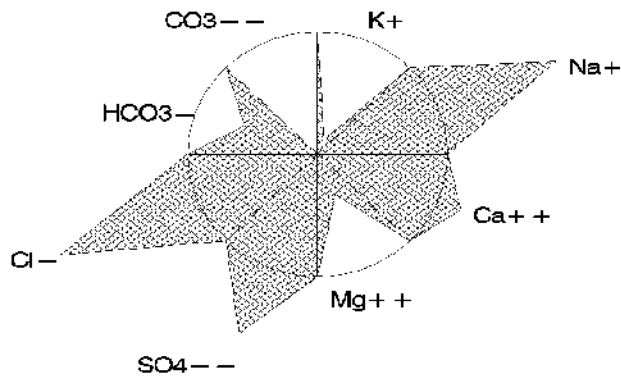

Gant Lake

Hillsborough County

USGS Quadrangle: Citrus Park Major Land Use/Land Cover (1990)
 Section/Township/Range: 1-28S-17E within 500 meters of the lakeshore:
 Approx. Lake Center, Lat/Long: 280420/823341 - high density residential (35%)
 Surface Area: 10 acres - low density residential (10%)
 Approx. Lake Elevation: 31 feet - cropland and pastureland (9%)
 Lake Type: isolated (type 4)
 Major Basin: Tampa Bay Drainage
 Minor Basin: Brushy Creek
 Lake Region: Keystone Lakes

Total Number of Samples Collected: 2 Most Recent Sample Collected: January 1996

Parameter	Units (Detection Limit)	Average Value	District Percentile	Florida Percentile
Chlorophyll a	ug/l (1)	3.3	28	14
Total Phosphorus	mg/l as P (0.01)	0.008	31	<5
Total Nitrogen	mg/l as N (0.06)	0.78	26	24
Transparency (Secchi depth)	meters	2.08	66	86
Florida Trophic State Index		33	35	7
Specific Conductance	S/cm at 25C (1)	724	>95	87
pH	standard units (0.1)	7.0	34	30
Color	PtCo units (1)	48	77	38
Turbidity	NTU (1)	0.5	28	<5
Total Alkalinity	mg/l as CaCO3 (1)	13	32	31
Hardness	mg/l as CaCO3 (0.02)	34	27	
Total Suspended Solids	mg/l (0.05)	0.6	15	
Ammonia	mg/l as N (0.03)	0.092	86	
Nitrate+Nitrite	mg/l as N (0.01)	0.011	37	
Total Kjeldahl Nitrogen	mg/l as N (0.06)	0.77	31	
Orthophosphorus	mg/l as P (0.01)	0.008	56	
Chloride	mg/l (0.05)	11	19	
Sulfate	mg/l (0.05)	21	63	
Sodium	mg/l (0.06)	7.1	34	
Potassium	mg/l (0.07)	1.3	22	
Calcium	mg/l (0.04)	9.1	34	
Magnesium	mg/l (0.006)	2.7	40	
Iron	ug/l (0.03)	82	75	

Based upon the average FTSI of 33, water quality is considered good. Gant Lake can be characterized as a colored, soft water, oligotrophic lake, with low concentrations of total phosphorus. The chemical type of water (predominant ionic composition) is calcium sulfate.

Plots and Trends: No or insufficient data available for plotting or trend detection. Shown is a diagram of the relative ionic composition of the lake water.

MAJOR IONS (% meq/l)

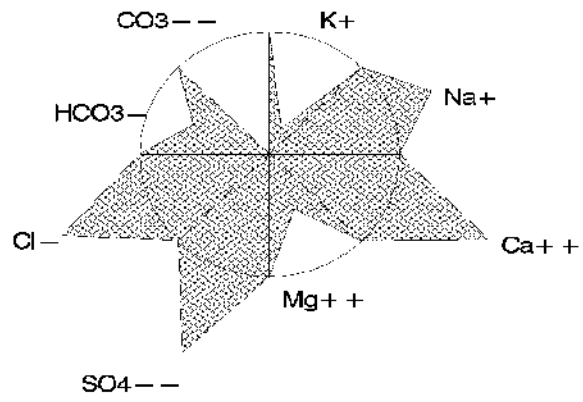

Golden Trout Lake Hillsborough County

USGS Quadrangle:	Sulphur Springs	Major Land Use/Land Cover (1990)
Section/Township/Range:	2-28S-18E	within 500 meters of the lakeshore:
Approx. Lake Center, Lat/Long:	280427/822818	- high density residential (37%)
Surface Area:	10 acres	- medium density residential (23%)
Approx. Lake Elevation:	43 feet	- low density residential (14%)
Lake Type:	isolated (type 4)	
Major Basin:	Hillsborough River	
Minor Basin:	Curiosity Creek	
Lake Region:	Land-o-Lakes	

Total Number of Samples Collected: 2 Most Recent Sample Collected: January 1996

Parameter	Units (Detection Limit)	Average Value	District Percentile	Florida Percentile
Chlorophyll a	ug/l (1)	4.4	40	18
Total Phosphorus	mg/l as P (0.01)	0.014	50	7
Total Nitrogen	mg/l as N (0.06)	1.39	65	50
Transparency (Secchi depth)	meters	1.80	58	82
Florida Trophic State Index		31	33	6
Specific Conductance	S/cm at 25C (1)	191	55	50
pH	standard units (0.1)	6.7	21	23
Color	PtCo units (1)	20	55	17
Turbidity	NTU (1)	0.5	28	<5
Total Alkalinity	mg/l as CaCO3 (1)	27	54	46
Hardness	mg/l as CaCO3 (0.02)	50	53	
Total Suspended Solids	mg/l (0.05)	0.9	24	
Ammonia	mg/l as N (0.03)	0.046	72	
Nitrate+Nitrite	mg/l as N (0.01)	0.017	46	
Total Kjeldahl Nitrogen	mg/l as N (0.06)	1.37	72	
Orthophosphorus	mg/l as P (0.01)	0.005	56	
Chloride	mg/l (0.05)	20	56	
Sulfate	mg/l (0.05)	28	74	
Sodium	mg/l (0.06)	9.6	56	
Potassium	mg/l (0.07)	5.3	68	
Calcium	mg/l (0.04)	17.3	66	
Magnesium	mg/l (0.006)	3.4	50	
Iron	ug/l (0.03)	30	39	

Based upon the average FTSI of 31, water quality is considered good. Golden Trout Lake can be characterized as a moderately colored, soft water, mesotrophic lake. The chemical type of water (predominant ionic composition) is calcium chloride (1 sample) or calcium sulfate (1 sample).

Also of note:

- Melaleuca was observed on the lake shore.
- Cattails dominate more than 30% of the lake shoreline.

Plots and Trends: No or insufficient data available for plotting or trend detection. Shown is a diagram of the relative ionic composition of the lake water.

MAJOR IONS (% meq/l)

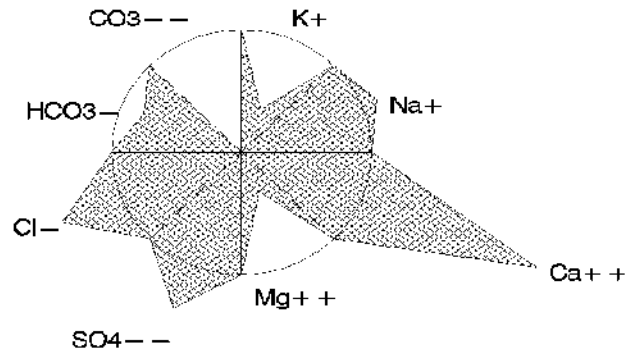

Golden Trout Lake, Hillsborough County

Gornto Lake

Hillsborough County

USGS Quadrangle: Brandon Major Land Use/Land Cover (1990)
 Section/Township/Range: 21-29S-19E within 500 meters of the lakeshore:
 Approx. Lake Center, Lat/Long: 275642/821901 - low density residential (33%)
 Surface Area: 17 acres - hardwood - conifer mixed (25%)
 Approx. Lake Elevation: 39 feet - cropland and pastureland (14%)
 Lake Type: isolated (type 4)
 Major Basin: Tampa Bay Drainage
 Minor Basin: Delaney Creek
 Lake Region: Hillsborough Valley

Total Number of Samples Collected: 2 Most Recent Sample Collected: January 1996

Parameter	Units (Detection Limit)	Average Value	District Percentile	Florida Percentile
Chlorophyll a	ug/l (1)	26.1	84	60
Total Phosphorus	mg/l as P (0.01)	0.030	77	20
Total Nitrogen	mg/l as N (0.06)	0.85	29	28
Transparency (Secchi depth)	meters	1.33	46	73
Florida Trophic State Index		50	73	35
Specific Conductance	S/cm at 25C (1)	201	59	52
pH	standard units (0.1)	8.6	92	85
Color	PtCo units (1)	23	58	19
Turbidity	NTU (1)	4.0	70	42
Total Alkalinity	mg/l as CaCO3 (1)	15	36	33
Hardness	mg/l as CaCO3 (0.02)	41	38	
Total Suspended Solids	mg/l (0.05)	6.2	82	
Ammonia	mg/l as N (0.03)	0.025	60	
Nitrate+Nitrite	mg/l as N (0.01)	0.161	85	
Total Kjeldahl Nitrogen	mg/l as N (0.06)	0.69	23	
Orthophosphorus	mg/l as P (0.01)	0.009	56	
Chloride	mg/l (0.05)	36	93	
Sulfate	mg/l (0.05)	19	58	
Sodium	mg/l (0.06)	19.5	92	
Potassium	mg/l (0.07)	1.6	27	
Calcium	mg/l (0.04)	13.0	53	
Magnesium	mg/l (0.006)	2.0	25	
Iron	ug/l (0.03)	58	67	

Based upon the average FTSI of 50, water quality is considered good. Gornto Lake can be characterized as a moderately colored, soft water, eutrophic lake. The chemical type of water (predominant ionic composition) is sodium chloride.

Also of note:

- The measured pH was high.

Plots and Trends: Lake surface elevation has generally been stable over the period of record, although a recent elevation of 39.4 feet is nearly 10 feet greater than the lowest elevations recorded at the beginning of the period of record, in 1979. Also shown is a diagram of the relative ionic composition of the lake water.

MONTHLY AVERAGE SURFACE ELEVATION

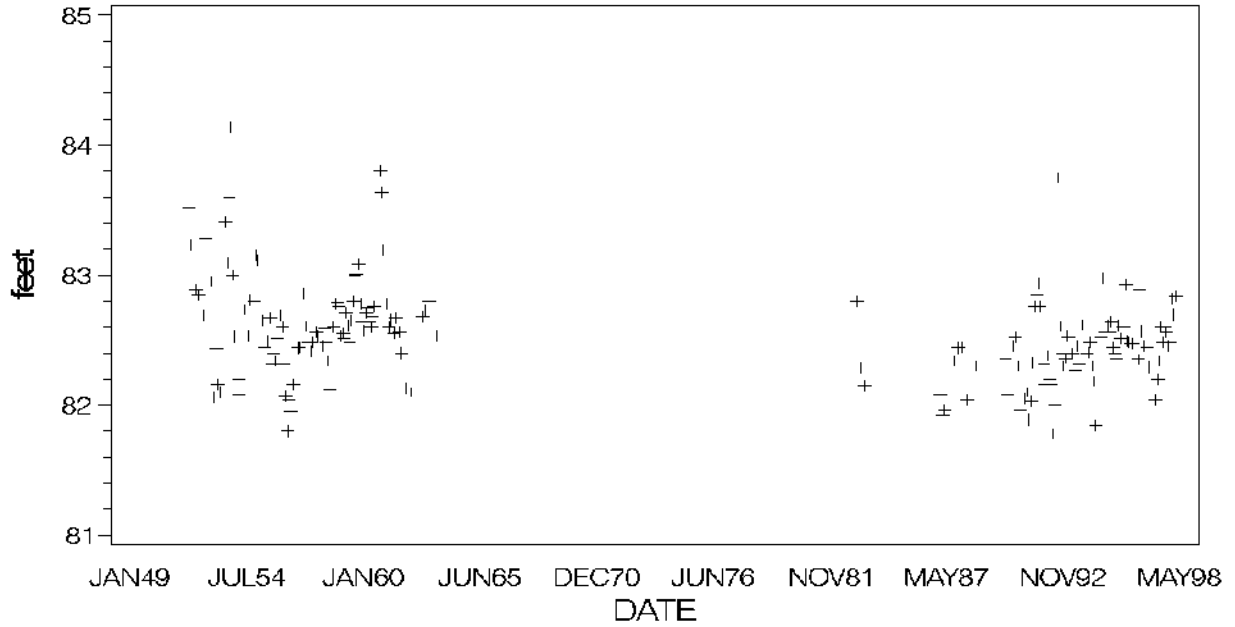

MAJOR IONS (% meq/l)

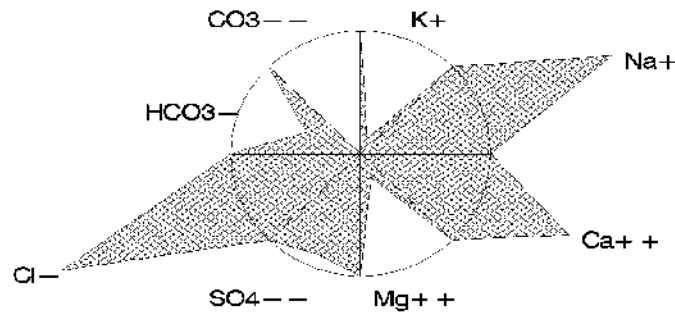

Grace Lake Hillsborough County

USGS Quadrangle:	Citrus Park	Major Land Use/Land Cover (1990)
Section/Township/Range:	34-27S-17E	within 500 meters of the lakeshore:
Approx. Lake Center, Lat/Long:	280549/823517	- medium density residential (26%)
Surface Area:	15 acres	- hardwood - conifer mixed (22%)
Approx. Lake Elevation:	33 feet	- other open lands - rural (20%)
Lake Type:	inflow and outflow (type 3)	
Major Basin:	Tampa Bay Drainage	
Minor Basin:	Double Branch	
Lake Region:	Keystone Lakes	

Total Number of Samples Collected: 2 Most Recent Sample Collected: February 1997

Parameter	Units (Detection Limit)	Average Value	District Percentile	Florida Percentile
Chlorophyll a	ug/l (1)	3.3	28	14
Total Phosphorus	mg/l as P (0.01)	0.005	31	<5
Total Nitrogen	mg/l as N (0.06)	0.45	<5	8
Transparency (Secchi depth)	meters	4.20	94	>95
Florida Trophic State Index		29	24	<5
Specific Conductance	S/cm at 25C (1)	205	61	53
pH	standard units (0.1)	7.0	34	30
Color	PtCo units (1)	10	34	10
Turbidity	NTU (1)	0.5	28	<5
Total Alkalinity	mg/l as CaCO3 (1)	17	39	35
Hardness	mg/l as CaCO3 (0.02)	39	34	
Total Suspended Solids	mg/l (0.05)	0.5	11	
Ammonia	mg/l as N (0.03)	0.015	60	
Nitrate+Nitrite	mg/l as N (0.01)	0.005	33	
Total Kjeldahl Nitrogen	mg/l as N (0.06)	0.45	6	
Orthophosphorus	mg/l as P (0.01)	0.005	56	
Chloride	mg/l (0.05)	41	95	
Sulfate	mg/l (0.05)	19	58	
Sodium	mg/l (0.06)	20.5	93	
Potassium	mg/l (0.07)	3.9	54	
Calcium	mg/l (0.04)	10.5	41	
Magnesium	mg/l (0.006)	3.1	47	
Iron	ug/l (0.03)	38	50	

Based upon the average FTSI of 29, water quality is considered good. Grace Lake can be characterized as a clear (color<=10 color units), soft water, oligo-mesotrophic lake, with low concentrations of total phosphorus, very low concentrations of total nitrogen. The chemical type of water (predominant ionic composition) is sodium chloride.

Plots and Trends: The record of lake elevation is incomplete, but shows some periods when lake levels were extremely low. The range in surface elevation fluctuation over the period of record is 15 feet. Also shown is a diagram of the relative ionic composition of the lake water.

MONTHLY AVERAGE SURFACE ELEVATION

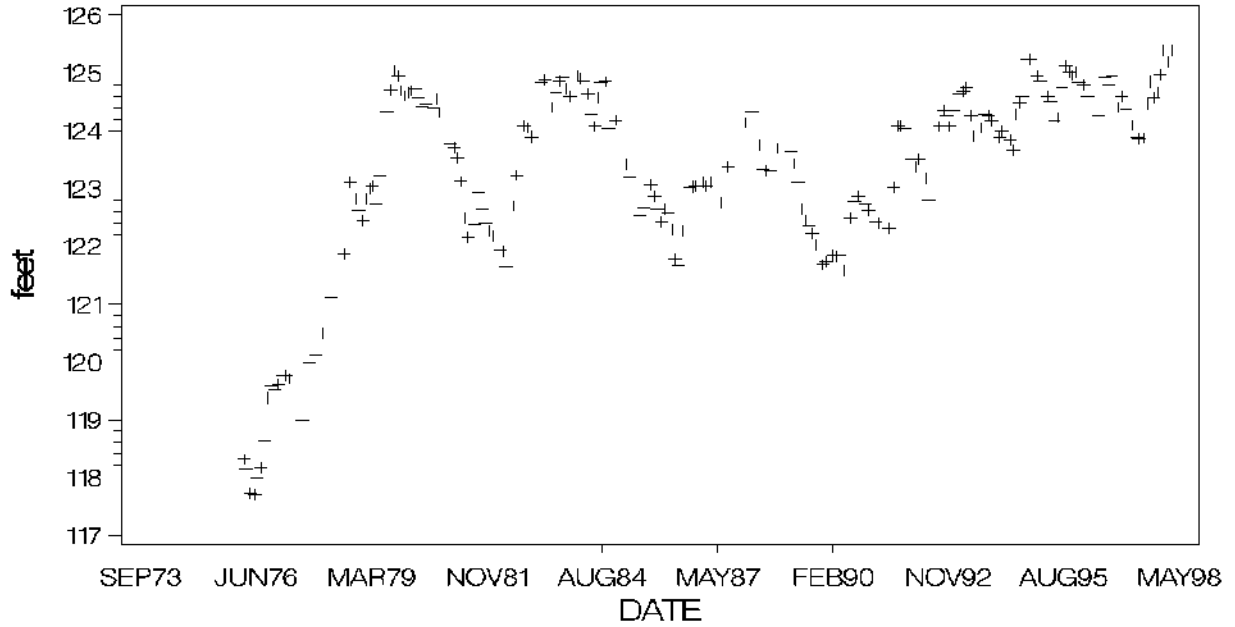

MAJOR IONS (% meq/l)

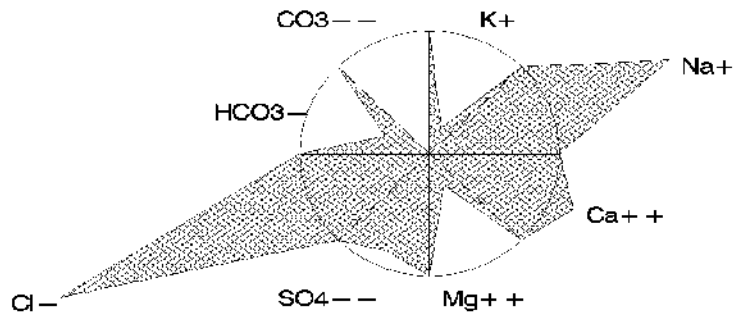

Halfmoon Lake Hillsborough County

USGS Quadrangle: Citrus Park Major Land Use/Land Cover (1990)
 Section/Township/Range: 31-27S-18E within 500 meters of the lakeshore:
 Approx. Lake Center, Lat/Long: 280546/823251 - medium density residential (35%)
 Surface Area: 32 acres - other open lands - rural (11%)
 Approx. Lake Elevation: 45 feet - tree crops, typically citrus (10%)
 Average Depth: 8.2 feet
 Observed Maximum Depth: 15.3 feet
 (reference elevation 44.3 feet)
 Lake Type: outflow (type 2)
 Major Basin: Tampa Bay Drainage
 Minor Basin: Halfmoon Lake Drain
 Lake Region: Keystone Lakes

Total Number of Samples Collected: 20 Most Recent Sample Collected: May 1997

Parameter	Units (Detection Limit)	Average Value	District Percentile	Florida Percentile
Chlorophyll a	ug/l (1)	3.0	25	13
Total Phosphorus	mg/l as P (0.01)	0.009	31	<5
Total Nitrogen	mg/l as N (0.06)	0.70	17	20
Transparency (Secchi depth)	meters	2.43	74	91
Florida Trophic State Index		28	22	<5
Specific Conductance	S/cm at 25C (1)	187	54	50
pH	standard units (0.1)	6.3	10	13
Color	PtCo units (1)	9	30	9
Turbidity	NTU (1)	1.4	39	11
Total Alkalinity	mg/l as CaCO3 (1)	4	10	10
Hardness	mg/l as CaCO3 (0.02)	27	18	
Total Suspended Solids	mg/l (0.05)	1.3	35	
Ammonia	mg/l as N (0.03)	0.039	68	
Nitrate+Nitrite	mg/l as N (0.01)	0.016	45	
Total Kjeldahl Nitrogen	mg/l as N (0.06)	0.69	23	
Orthophosphorus	mg/l as P (0.01)	0.006	56	
Chloride	mg/l (0.05)	26	78	
Sulfate	mg/l (0.05)	23	67	
Sodium	mg/l (0.06)	15.0	83	
Potassium	mg/l (0.07)	2.6	42	
Calcium	mg/l (0.04)	7.2	25	
Magnesium	mg/l (0.006)	2.9	43	
Iron	ug/l (0.03)	25	31	

Based upon the average FTSI of 28, water quality is considered good. Halfmoon Lake can be characterized as a clear (color<=10 color units), soft water, oligo-mesotrophic lake, with low concentrations of total phosphorus. The chemical type of water (predominant ionic composition) is sodium chloride.

Plots and Trends: The large dip in the lake surface elevation in the mid-1990s is typical of many lakes in the Northwest Hillsborough region. Nearly two-thirds of the lakes sampled in the area had the lowest elevations for their individual periods of record between 1991 and 1995. Halfmoon Lake levels have since recovered from the drought period. Also shown is a diagram of the relative ionic composition of the lake water.

MONTHLY AVERAGE SURFACE ELEVATION

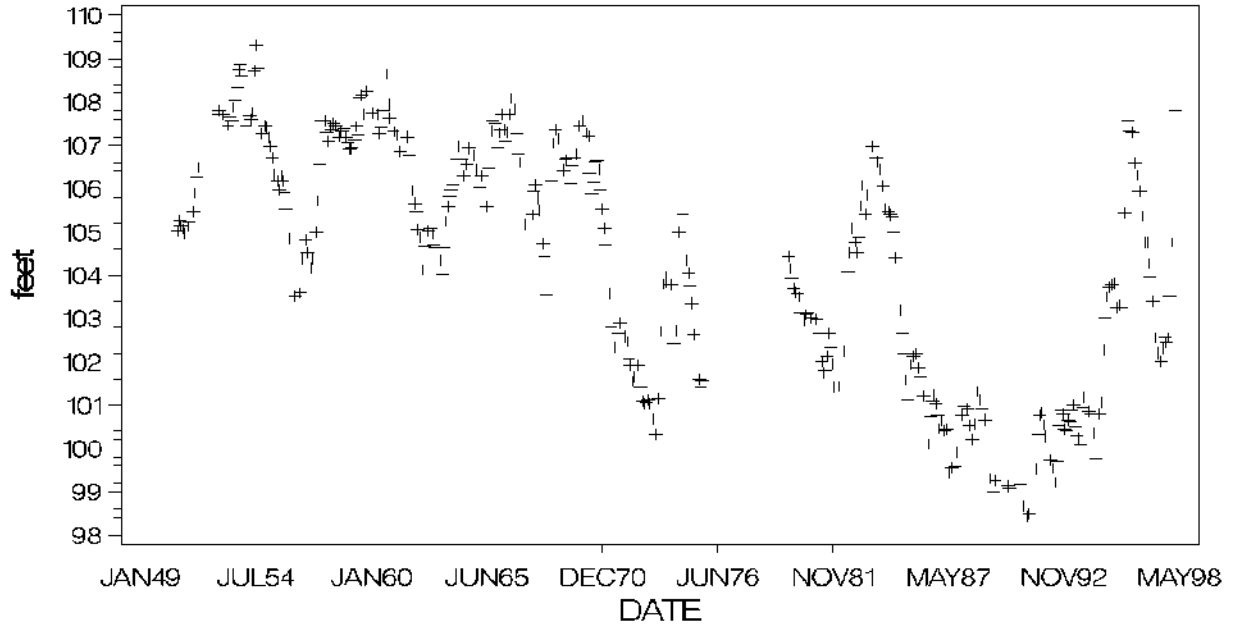

MAJOR IONS (% meq/l)

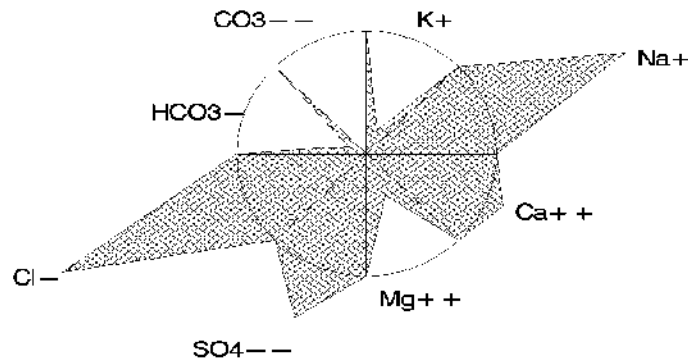

Halfmoon Lake, Hillsborough County

Lake Helen Hillsborough County

USGS Quadrangle: Citrus Park Major Land Use/Land Cover (1990)
 Section/Township/Range: 19-27S-18E within 500 meters of the lakeshore:
 Approx. Lake Center, Lat/Long: 280717/823219 - low density residential (51%)
 Surface Area: 16 acres - cropland and pastureland (21%)
 Approx. Lake Elevation: 53 feet - medium density residential (8%)
 Average Depth: 9.4 feet
 Observed Maximum Depth: 16 feet
 (reference elevation 53 feet)
 Lake Type: inflow and outflow (type 3)
 Major Basin: Tampa Bay Drainage
 Minor Basin: Upper Rocky Creek
 Lake Region: Keystone Lakes

Total Number of Samples Collected: 4 Most Recent Sample Collected: January 1997

Parameter	Units (Detection Limit)	Average Value	District Percentile	Florida Percentile
Chlorophyll a	ug/l (1)	1.8	10	7
Total Phosphorus	mg/l as P (0.01)	0.012	41	6
Total Nitrogen	mg/l as N (0.06)	0.40	<5	5
Transparency (Secchi depth)	meters	3.66	91	>95
Florida Trophic State Index		21	8	<5
Specific Conductance	S/cm at 25C (1)	301	88	69
pH	standard units (0.1)	7.2	43	40
Color	PtCo units (1)	15	46	13
Turbidity	NTU (1)	0.6	28	<5
Total Alkalinity	mg/l as CaCO3 (1)	23	46	42
Hardness	mg/l as CaCO3 (0.02)	44	43	
Total Suspended Solids	mg/l (0.05)	0.7	18	
Ammonia	mg/l as N (0.03)	0.032	63	
Nitrate+Nitrite	mg/l as N (0.01)	0.012	40	
Total Kjeldahl Nitrogen	mg/l as N (0.06)	0.40	<5	
Orthophosphorus	mg/l as P (0.01)	0.009	56	
Chloride	mg/l (0.05)	65	>95	
Sulfate	mg/l (0.05)	14	48	
Sodium	mg/l (0.06)	38.5	>95	
Potassium	mg/l (0.07)	1.9	32	
Calcium	mg/l (0.04)	13.8	55	
Magnesium	mg/l (0.006)	2.4	35	
Iron	ug/l (0.03)	25	31	

Based upon the average FTSI of 21, water quality is considered good. Lake Helen can be characterized as a clear to moderately colored (10<color<20 color units), soft water, oligotrophic lake, with very low concentrations of total nitrogen. The chemical type of water (predominant ionic composition) is sodium chloride.

Plots and Trends: No or insufficient data available for plotting or trend detection. Shown is a diagram of the relative ionic composition of the lake water.

MAJOR IONS (% meq/l)

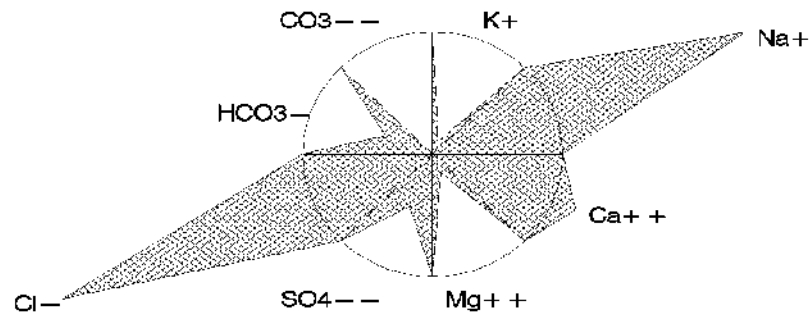

Lake Helen, Hillsborough County

Hog Island Lake

Hillsborough County

USGS Quadrangle: Lutz Major Land Use/Land Cover (1990)
 Section/Township/Range: 6-27S-19E within 500 meters of the lakeshore:
 Approx. Lake Center, Lat/Long: 281009/822656 - other open lands - rural (31%)
 Surface Area: 47 acres - freshwater marshes (20%)
 Approx. Lake Elevation: 66 feet - low density residential (11%)
 Lake Type: isolated (type 4)
 Major Basin: Hillsborough River
 Minor Basin: Cypress Creek
 Lake Region: Land-o-Lakes

Total Number of Samples Collected: 2 Most Recent Sample Collected: January 1995

Parameter	Units (Detection Limit)	Average Value	District Percentile	Florida Percentile
Chlorophyll a	ug/l (1)	4.7	42	19
Total Phosphorus	mg/l as P (0.01)	0.025	72	15
Total Nitrogen	mg/l as N (0.06)	1.04	43	35
Transparency (Secchi depth)	meters	1.85	59	83
Florida Trophic State Index		41	54	17
Specific Conductance	S/cm at 25C (1)	185	53	49
pH	standard units (0.1)	6.6	18	20
Color	PtCo units (1)	10	34	10
Turbidity	NTU (1)	1.8	47	17
Total Alkalinity	mg/l as CaCO3 (1)	14	33	32
Hardness	mg/l as CaCO3 (0.02)	49	51	
Total Suspended Solids	mg/l (0.05)	2.0	51	
Ammonia	mg/l as N (0.03)	0.038	67	
Nitrate+Nitrite	mg/l as N (0.01)	0.047	68	
Total Kjeldahl Nitrogen	mg/l as N (0.06)	0.99	47	
Orthophosphorus	mg/l as P (0.01)	0.005	56	
Chloride	mg/l (0.05)	22	64	
Sulfate	mg/l (0.05)	30	77	
Sodium	mg/l (0.06)	10.0	58	
Potassium	mg/l (0.07)	6.3	76	
Calcium	mg/l (0.04)	9.1	34	
Magnesium	mg/l (0.006)	6.3	78	
Iron	ug/l (0.03)	35	47	

Based upon the average FTSI of 41, water quality is considered good. Hog Island Lake can be characterized as a clear (color<=10 color units), soft water, meso-eutrophic lake. The chemical type of water (predominant ionic composition) is calcium sulfate (1 sample) or sodium chloride (1 sample).

Also of note:

- Cattails dominate more than 30% of the lake shoreline.

Plots and Trends: No or insufficient data available for plotting or trend detection. Shown is a diagram of the relative ionic composition of the lake water.

MAJOR IONS (% meq/l)

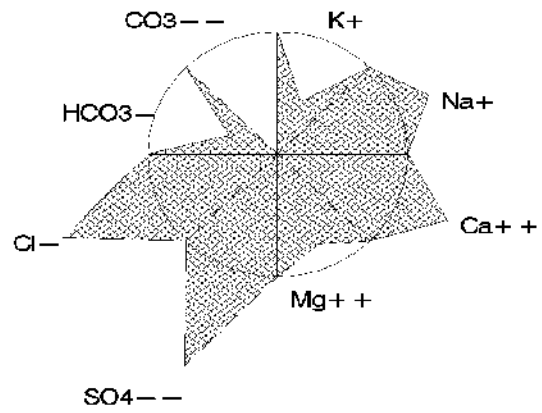

Hog Island Lake, Hillsborough County

Horse Lake

Hillsborough County

USGS Quadrangle: Citrus Park Major Land Use/Land Cover (1990)
 Section/Township/Range: 26-27S-17E within 500 meters of the lakeshore:
 Approx. Lake Center, Lat/Long: 280638/823446 - hardwood - conifer mixed (24%)
 Surface Area: 28 acres - tree crops, typically citrus (20%)
 Approx. Lake Elevation: 47 feet - other open lands - rural (15%)
 Average Depth: 4.4 feet
 Observed Maximum Depth: 16.9 feet
 (reference elevation 46.9 feet)
 Lake Type: isolated (type 4)
 Major Basin: Tampa Bay Drainage
 Minor Basin: Horse Lake
 Lake Region: Keystone Lakes

Total Number of Samples Collected: 2 Most Recent Sample Collected: January 1995

Parameter	Units (Detection Limit)	Average Value	District Percentile	Florida Percentile
Chlorophyll a	ug/l (1)	5.1	45	21
Total Phosphorus	mg/l as P (0.01)	0.008	31	<5
Total Nitrogen	mg/l as N (0.06)	2.18	87	84
Transparency (Secchi depth)	meters	1.80	58	82
Florida Trophic State Index		35	42	10
Specific Conductance	S/cm at 25C (1)	221	67	55
pH	standard units (0.1)	6.6	18	20
Color	PtCo units (1)	10	34	10
Turbidity	NTU (1)	1.5	41	13
Total Alkalinity	mg/l as CaCO3 (1)	6	15	17
Hardness	mg/l as CaCO3 (0.02)	66	69	
Total Suspended Solids	mg/l (0.05)	2.0	51	
Ammonia	mg/l as N (0.03)	0.182	>95	
Nitrate+Nitrite	mg/l as N (0.01)	0.067	76	
Total Kjeldahl Nitrogen	mg/l as N (0.06)	2.11	92	
Orthophosphorus	mg/l as P (0.01)	0.005	56	
Chloride	mg/l (0.05)	23	69	
Sulfate	mg/l (0.05)	54	94	
Sodium	mg/l (0.06)	8.8	50	
Potassium	mg/l (0.07)	5.5	70	
Calcium	mg/l (0.04)	14.0	56	
Magnesium	mg/l (0.006)	7.5	82	
Iron	ug/l (0.03)	26	32	

Based upon the average FTSI of 35, water quality is considered good. Horse Lake can be characterized as a clear (color<=10 color units), medium hard water, mesotrophic lake, with low concentrations of total phosphorus and high concentrations of total nitrogen. The chemical type of water (predominant ionic composition) is calcium sulfate.

Plots and Trends: Horse Lake has a period of record that spans over 50 years. Lake levels appear to have declined beginning in the 1940s or 1950s, and continued into the 1980s. The lake is in close proximity to a linear well field, which may have affected lake levels over time. From January through March of 1998 (not shown on the plot), water was pumped from nearby Lake Rogers to Horse Lake, to raise the lake levels. Also shown is a diagram of the relative ionic composition of the lake water.

MONTHLY AVERAGE SURFACE ELEVATION

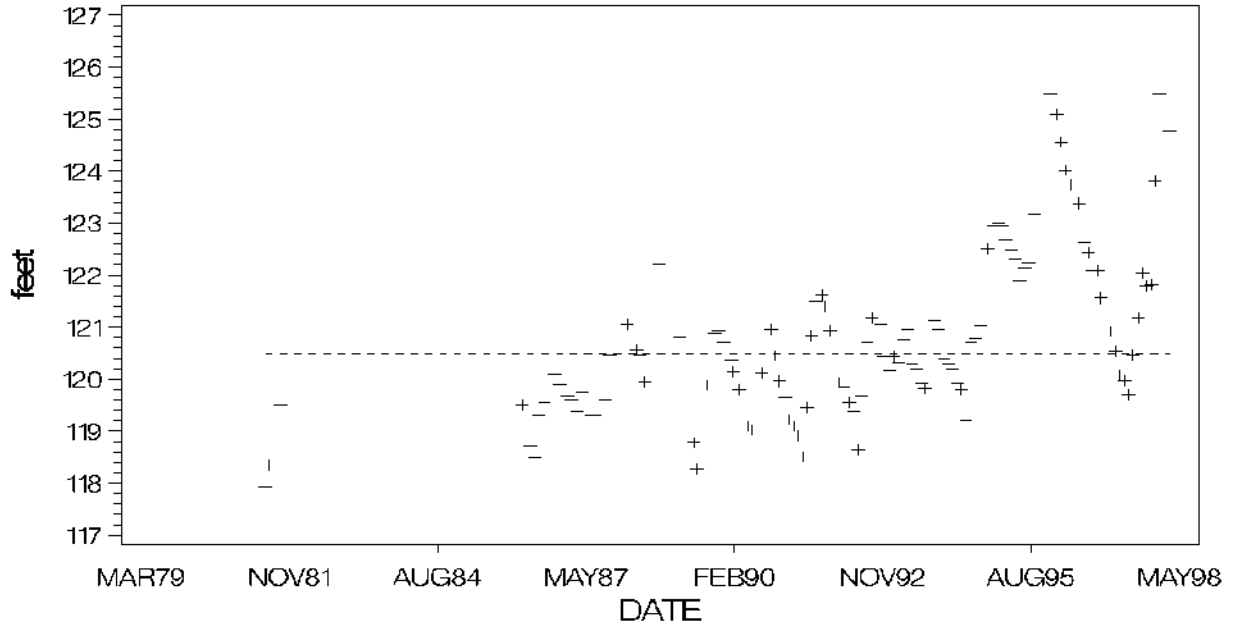

MAJOR IONS (% meq/l)

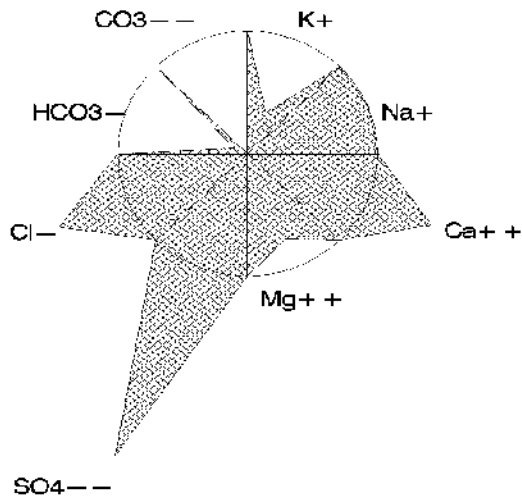

Island Ford Lake

Hillsborough County

USGS Quadrangle: Odessa Major Land Use/Land Cover (1990)
 Section/Township/Range: 10-27S-17E within 500 meters of the lakeshore:
 Approx. Lake Center, Lat/Long: 280909/823559 - low density residential (17%)
 Surface Area: 96 acres - cropland and pastureland (17%)
 Approx. Lake Elevation: 42 feet - medium density residential (13%)
 Average Depth: 11.2 feet
 Observed Maximum Depth: 25 feet
 (reference elevation not given)
 Lake Type: inflow and outflow (type 3)
 Major Basin: Tampa Bay Drainage
 Minor Basin: Brooker Creek
 Lake Region: Keystone Lakes

Total Number of Samples Collected: 2 Most Recent Sample Collected: January 1995

Parameter	Units (Detection Limit)	Average Value	District Percentile	Florida Percentile
Chlorophyll a	ug/l (1)	4.0	36	16
Total Phosphorus	mg/l as P (0.01)	0.011	38	6
Total Nitrogen	mg/l as N (0.06)	2.02	85	82
Transparency (Secchi depth)	meters	2.75	80	94
Florida Trophic State Index		31	33	6
Specific Conductance	S/cm at 25C (1)	117	18	30
pH	standard units (0.1)	6.5	15	18
Color	PtCo units (1)	8	24	8
Turbidity	NTU (1)	1.9	49	19
Total Alkalinity	mg/l as CaCO3 (1)	2	<5	5
Hardness	mg/l as CaCO3 (0.02)	23	12	
Total Suspended Solids	mg/l (0.05)	2.1	54	
Ammonia	mg/l as N (0.03)	0.076	84	
Nitrate+Nitrite	mg/l as N (0.01)	0.005	33	
Total Kjeldahl Nitrogen	mg/l as N (0.06)	2.02	90	
Orthophosphorus	mg/l as P (0.01)	0.005	56	
Chloride	mg/l (0.05)	18	46	
Sulfate	mg/l (0.05)	19	58	
Sodium	mg/l (0.06)	8.6	49	
Potassium	mg/l (0.07)	2.3	37	
Calcium	mg/l (0.04)	5.6	17	
Magnesium	mg/l (0.006)	2.2	31	
Iron	ug/l (0.03)	32	42	

Based upon the average FTSI of 31, water quality is considered good. Island Ford Lake can be characterized as a clear (color<=10 color units), soft water, mesotrophic lake, with high concentrations of total nitrogen. The chemical type of water (predominant ionic composition) is sodium chloride.

Plots and Trends: Lake levels in Island Ford Lake are controlled to some extent by a Southwest Florida Water management District operable structure. Lake surface elevations have remained relatively stable over the period of record, the total range of fluctuation is approximately 5 feet. Recent specific conductance measurements are within the range of values measured sporadically in Island Ford Lake since the 1970s. Also shown is a diagram of the relative ionic composition of the lake water.

MONTHLY AVERAGE SURFACE ELEVATION

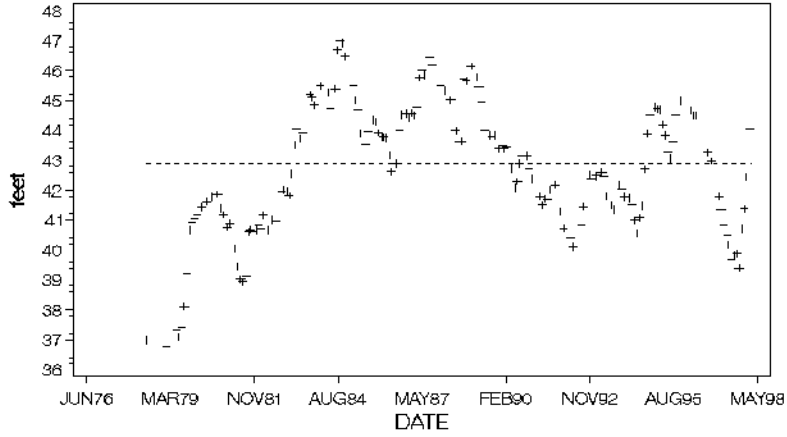

SPEC. CONDUCTANCE

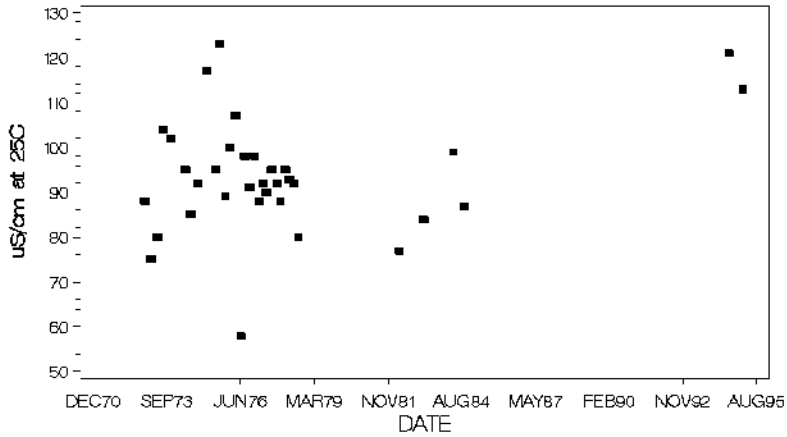

MAJOR IONS (% meq/l)

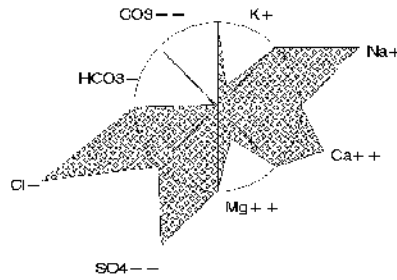

Island Ford Lake, Hillsborough County

Lake Jackson Hillsborough County

USGS Quadrangle: Elfers Major Land Use/Land Cover (1990)
 Section/Township/Range: 17-27S-17E within 500 meters of the lakeshore:
 Approx. Lake Center, Lat/Long: 280815/823748 - cropland and pastureland (41%)
 Surface Area: 10 acres - low density residential (24%)
 Approx. Lake Elevation: 34 feet - stream and lake swamps (15%)
 Average Depth: 4.2 feet
 Observed Maximum Depth: 16 feet
 (reference elevation 27 feet)
 Lake Type: inflow and outflow (type 3)
 Major Basin: Tampa Bay Drainage
 Minor Basin: Sunset Lake Outlet
 Lake Region: Keystone Lakes

Total Number of Samples Collected: 2 Most Recent Sample Collected: January 1996

Parameter	Units (Detection Limit)	Average Value	District Percentile	Florida Percentile
Chlorophyll a	ug/l (1)	8.4	59	34
Total Phosphorus	mg/l as P (0.01)	0.011	38	6
Total Nitrogen	mg/l as N (0.06)	1.93	83	80
Transparency (Secchi depth)	meters	2.40	74	91
Florida Trophic State Index		45	63	25
Specific Conductance	S/cm at 25C (1)	167	44	45
pH	standard units (0.1)	6.9	29	28
Color	PtCo units (1)	143	94	89
Turbidity	NTU (1)	0.5	28	<5
Total Alkalinity	mg/l as CaCO3 (1)	28	55	47
Hardness	mg/l as CaCO3 (0.02)	47	49	
Total Suspended Solids	mg/l (0.05)	0.9	24	
Ammonia	mg/l as N (0.03)	0.265	>95	
Nitrate+Nitrite	mg/l as N (0.01)	0.019	50	
Total Kjeldahl Nitrogen	mg/l as N (0.06)	1.91	88	
Orthophosphorus	mg/l as P (0.01)	0.005	56	
Chloride	mg/l (0.05)	27	80	
Sulfate	mg/l (0.05)	7	27	
Sodium	mg/l (0.06)	14.0	80	
Potassium	mg/l (0.07)	2.0	34	
Calcium	mg/l (0.04)	14.0	56	
Magnesium	mg/l (0.006)	2.8	41	
Iron	ug/l (0.03)	101	82	

Based upon the average FTSI of 45, water quality is considered good. Lake Jackson can be characterized as a highly colored, soft water, mesotrophic lake, with high concentrations of total nitrogen. The chemical type of water (predominant ionic composition) is calcium chloride (1 sample) or sodium chloride (1 sample).

Also of note: -
 - Hydrilla was observed in the lake.
 - Cattails dominate more than 30% of the lake shoreline.

Plots and Trends: The dip in the lake surface elevation in the early to mid-1990s is typical of many lakes in the Northwest Hillsborough region. Nearly two-thirds of the lakes sampled in the area had the lowest elevations for their individual periods of record between 1991 and 1995. Lake Jackson lake levels have since recovered from the drought period. Also shown is a diagram of the relative ionic composition of the lake water.

MONTHLY AVERAGE SURFACE ELEVATION

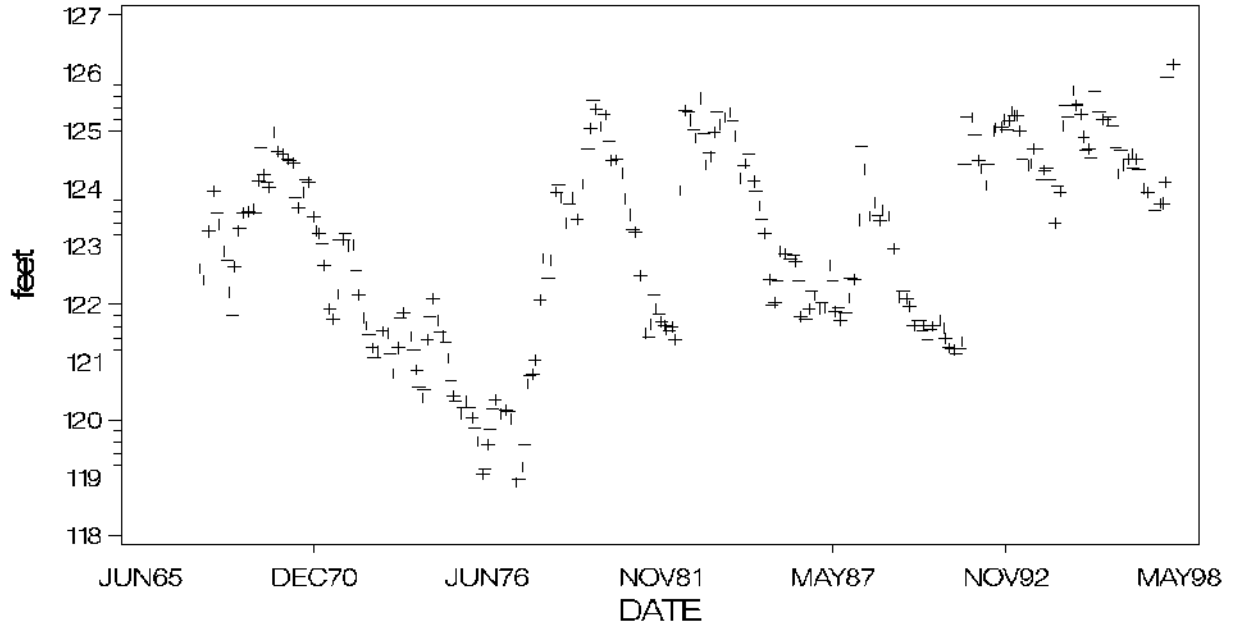

MAJOR IONS (% meq/l)

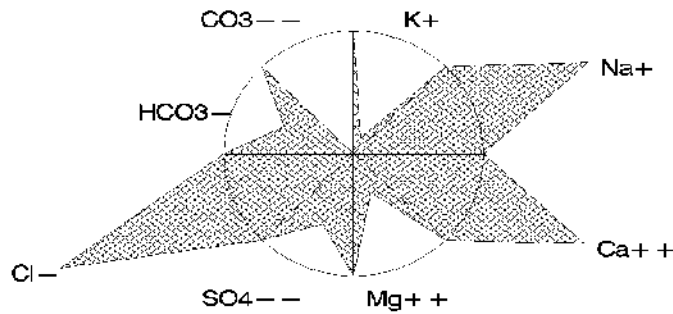

Lake Juanita

Hillsborough County

USGS Quadrangle: Citrus Park Major Land Use/Land Cover (1990)
 Section/Township/Range: 22-27S-17E within 500 meters of the lakeshore:
 Approx. Lake Center, Lat/Long: 280702/823521 - medium density residential (56%)
 Surface Area: 24 acres - hardwood - conifer mixed (13%)
 Approx. Lake Elevation: 42 feet - tree crops, typically citrus (8%)
 Average Depth: 8.4 feet
 Observed Maximum Depth: 16.7 feet
 (reference elevation 41.7 feet)
 Lake Type: outflow (type 2)
 Major Basin: Tampa Bay Drainage
 Minor Basin: Upper Brooker Creek
 Lake Region: Keystone Lakes

Total Number of Samples Collected: 2 Most Recent Sample Collected: January 1996

Parameter	Units (Detection Limit)	Average Value	District Percentile	Florida Percentile
Chlorophyll a	ug/l (1)	2.0	13	8
Total Phosphorus	mg/l as P (0.01)	0.008	31	<5
Total Nitrogen	mg/l as N (0.06)	0.66	15	18
Transparency (Secchi depth)	meters	-	-	-
Florida Trophic State Index		26	17	<5
Specific Conductance	S/cm at 25C (1)	156	40	43
pH	standard units (0.1)	7.0	34	30
Color	PtCo units (1)	5	9	5
Turbidity	NTU (1)	0.5	28	<5
Total Alkalinity	mg/l as CaCO3 (1)	6	15	17
Hardness	mg/l as CaCO3 (0.02)	28	19	
Total Suspended Solids	mg/l (0.05)	0.5	11	
Ammonia	mg/l as N (0.03)	0.053	77	
Nitrate+Nitrite	mg/l as N (0.01)	0.032	60	
Total Kjeldahl Nitrogen	mg/l as N (0.06)	0.63	18	
Orthophosphorus	mg/l as P (0.01)	0.008	56	
Chloride	mg/l (0.05)	26	78	
Sulfate	mg/l (0.05)	21	63	
Sodium	mg/l (0.06)	16.5	87	
Potassium	mg/l (0.07)	1.4	24	
Calcium	mg/l (0.04)	7.3	26	
Magnesium	mg/l (0.006)	2.3	33	
Iron	ug/l (0.03)	53	63	

Based upon the average FTSI of 26, water quality is considered good. Lake Juanita can be characterized as a clear (color<=10 color units), soft water, oligotrophic lake, with low concentrations of total phosphorus, low concentrations of total nitrogen. The chemical type of water (predominant ionic composition) is sodium chloride.

Plots and Trends: The large dip in the lake surface elevation in the mid-1990s is typical of many lakes in the Northwest Hillsborough region. Nearly two-thirds of the lakes sampled in the area had the lowest elevations for their individual periods of record between 1991 and 1995. Lake Juanita lake levels rebounded in 1998. Specific conductivity during 1995-1996 was generally higher than measured during the 1970s. Also shown is a diagram of the relative ionic composition of the lake water.

MONTHLY AVERAGE SURFACE ELEVATION

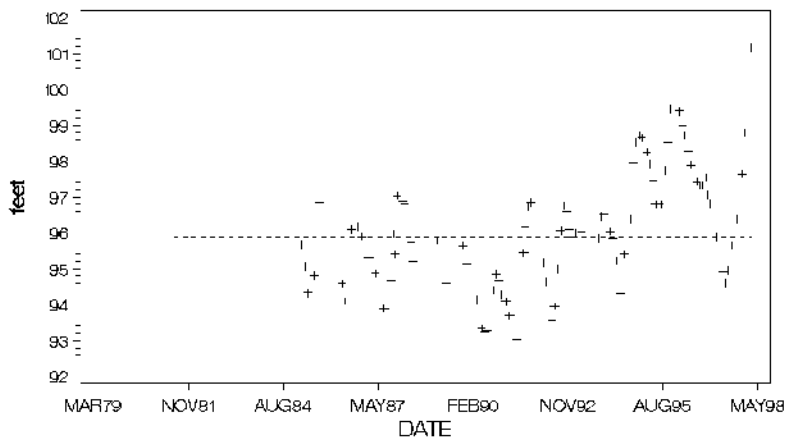

SPEC. CONDUCTANCE

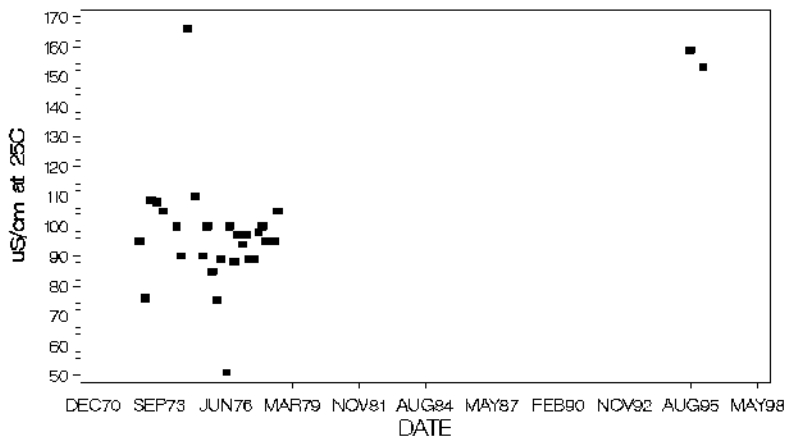

MAJOR IONS (% meq/l)

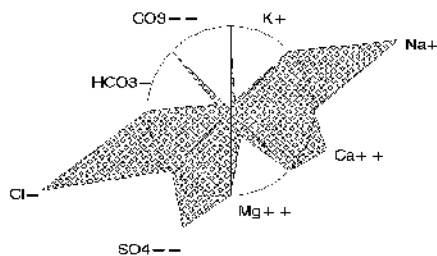

Keystone Lake Hillsborough County

USGS Quadrangle: Odessa Major Land Use/Land Cover (1990)
 Section/Township/Range: 15-27S-17E within 500 meters of the lakeshore:
 Approx. Lake Center, Lat/Long: 280759/823528 - medium density residential (42%)
 Surface Area: 417 acres - tree crops, typically citrus (18%)
 Approx. Lake Elevation: 42 feet - low density residential (15%)
 Average Depth: 8.5 feet
 (reference elevation 38 feet)
 Lake Type: inflow and outflow (type 3)
 Major Basin: Tampa Bay Drainage
 Minor Basin: Upper Brooker Creek
 Lake Region: Keystone Lakes

Total Number of Samples Collected: 2 Most Recent Sample Collected: January 1995

Parameter	Units (Detection Limit)	Average Value	District Percentile	Florida Percentile
Chlorophyll a	ug/l (1)	4.8	43	19
Total Phosphorus	mg/l as P (0.01)	0.008	31	<5
Total Nitrogen	mg/l as N (0.06)	1.08	47	36
Transparency (Secchi depth)	meters	2.70	78	93
Florida Trophic State Index		29	24	<5
Specific Conductance	S/cm at 25C (1)	122	21	32
pH	standard units (0.1)	6.1	6	9
Color	PtCo units (1)	10	34	10
Turbidity	NTU (1)	0.8	28	<5
Total Alkalinity	mg/l as CaCO3 (1)	3	7	8
Hardness	mg/l as CaCO3 (0.02)	24	13	
Total Suspended Solids	mg/l (0.05)	0.7	18	
Ammonia	mg/l as N (0.03)	0.015	60	
Nitrate+Nitrite	mg/l as N (0.01)	0.061	73	
Total Kjeldahl Nitrogen	mg/l as N (0.06)	1.02	49	
Orthophosphorus	mg/l as P (0.01)	0.005	56	
Chloride	mg/l (0.05)	20	56	
Sulfate	mg/l (0.05)	17	54	
Sodium	mg/l (0.06)	9.2	54	
Potassium	mg/l (0.07)	2.2	37	
Calcium	mg/l (0.04)	6.2	20	
Magnesium	mg/l (0.006)	2.1	28	
Iron	ug/l (0.03)	60	68	

Based upon the average FTSI of 29, water quality is considered good. Keystone Lake can be characterized as a clear (color<=10 color units), soft water, mesotrophic lake, with low concentrations of total phosphorus. The chemical type of water (predominant ionic composition) is sodium chloride.

Plots and Trends: Lake surface elevations for Lake Keystone have been remarkably stable over the period of record. The lake typically fluctuates within a range of approximately 4 feet. The recent measurements of specific conductivity are similar to those made during the 1970s and 1980s. Also shown is a diagram of the relative ionic composition of the lake water.

MONTHLY AVERAGE SURFACE ELEVATION

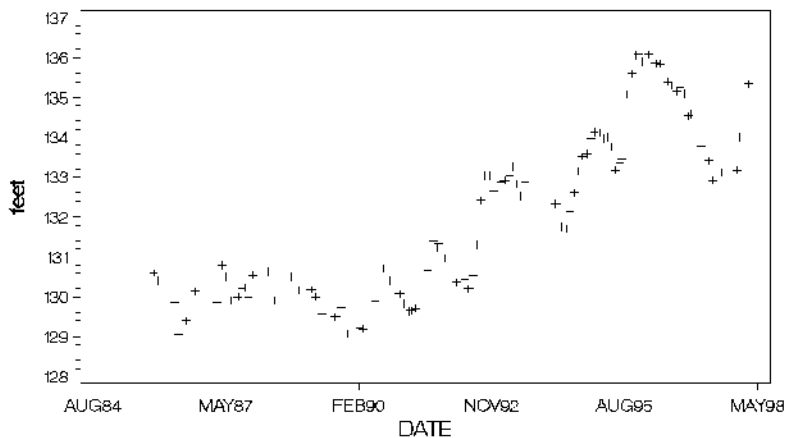

SPEC. CONDUCTANCE

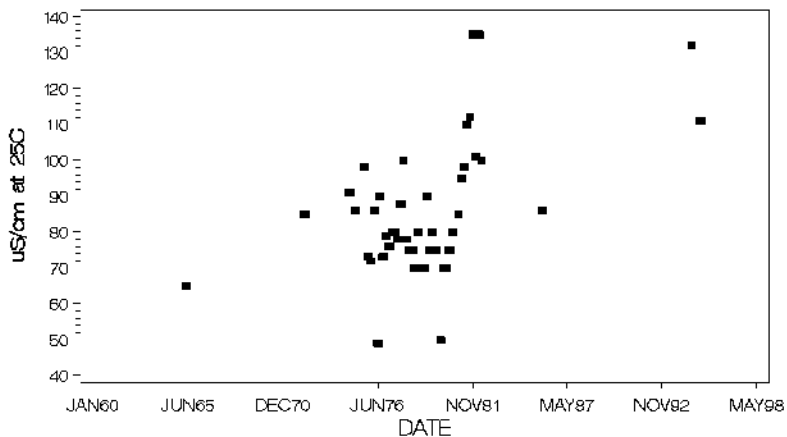

MAJOR IONS (% meq/l)

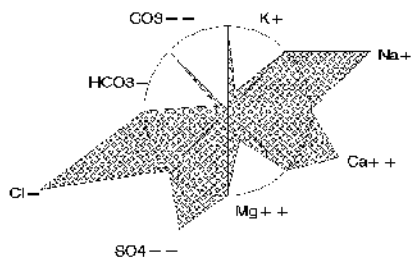

Keystone Lake, Hillsborough County

Little Halfmoon Lake Hillsborough County

USGS Quadrangle: Citrus Park Major Land Use/Land Cover (1990)
 Section/Township/Range: 30-27S-18E within 500 meters of the lakeshore:
 Approx. Lake Center, Lat/Long: 280611/823300 - medium density residential (26%)
 Surface Area: 12 acres - other open lands - rural (18%)
 Approx. Lake Elevation: 48 feet - wetland forested mixed (14%)
 Average Depth: 5.2 feet
 (reference elevation 43 feet)
 Lake Type: isolated (type 4)
 Major Basin: Tampa Bay Drainage
 Minor Basin: Halfmoon Lake Drain
 Lake Region: Keystone Lakes

Total Number of Samples Collected: 2 Most Recent Sample Collected: January 1996

Parameter	Units (Detection Limit)	Average Value	District Percentile	Florida Percentile
Chlorophyll a	ug/l (1)	1.2	<5	<5
Total Phosphorus	mg/l as P (0.01)	0.008	31	<5
Total Nitrogen	mg/l as N (0.06)	0.89	31	30
Transparency (Secchi depth)	meters	2.78	80	94
Florida Trophic State Index		20	7	<5
Specific Conductance	S/cm at 25C (1)	253	78	61
pH	standard units (0.1)	6.2	8	10
Color	PtCo units (1)	28	65	22
Turbidity	NTU (1)	0.5	28	<5
Total Alkalinity	mg/l as CaCO3 (1)	9	24	24
Hardness	mg/l as CaCO3 (0.02)	44	43	
Total Suspended Solids	mg/l (0.05)	0.3	<5	
Ammonia	mg/l as N (0.03)	0.133	92	
Nitrate+Nitrite	mg/l as N (0.01)	0.040	65	
Total Kjeldahl Nitrogen	mg/l as N (0.06)	0.85	35	
Orthophosphorus	mg/l as P (0.01)	0.008	56	
Chloride	mg/l (0.05)	43	>95	
Sulfate	mg/l (0.05)	35	85	
Sodium	mg/l (0.06)	24.0	95	
Potassium	mg/l (0.07)	6.3	76	
Calcium	mg/l (0.04)	12.0	48	
Magnesium	mg/l (0.006)	3.4	50	
Iron	ug/l (0.03)	55	64	

Based upon the average FTSI of 20, water quality is considered good. Little Halfmoon Lake can be characterized as a moderately colored, soft water, oligotrophic lake, with low concentrations of total phosphorus. The chemical type of water (predominant ionic composition) is sodium chloride.

Plots and Trends: No or insufficient data available for plotting or trend detection. Shown is a diagram of the relative ionic composition of the lake water.

MAJOR IONS (% meq/l)

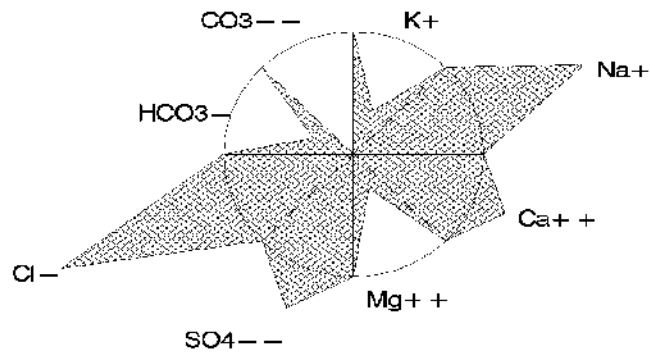

Little Halfmoon Lake, Hillsborough County

Little Moon Lake

Hillsborough County

USGS Quadrangle: Citrus Park Major Land Use/Land Cover (1990)
 Section/Township/Range: 28-27S-17E within 500 meters of the lakeshore:
 Approx. Lake Center, Lat/Long: 280648/823602 - medium density residential (36%)
 Surface Area: 13 acres - tree crops, typically citrus (31%)
 Approx. Lake Elevation: 39 feet - hardwood - conifer mixed (10%)
 Average Depth: 10.9 feet
 Observed Maximum Depth: 20 feet
 (reference elevation 39 feet)
 Lake Type: inflow (type 1)
 Major Basin: Tampa Bay Drainage
 Minor Basin: Unnamed Ditch
 Lake Region: Keystone Lakes

Total Number of Samples Collected: 4 Most Recent Sample Collected: January 1997

Parameter	Units (Detection Limit)	Average Value	District Percentile	Florida Percentile
Chlorophyll a	ug/l (1)	1.8	10	7
Total Phosphorus	mg/l as P (0.01)	0.009	31	<5
Total Nitrogen	mg/l as N (0.06)	0.62	12	16
Transparency (Secchi depth)	meters	3.25	88	>95
Florida Trophic State Index		24	11	<5
Specific Conductance	S/cm at 25C (1)	265	82	63
pH	standard units (0.1)	6.9	29	28
Color	PtCo units (1)	8	24	8
Turbidity	NTU (1)	0.5	28	<5
Total Alkalinity	mg/l as CaCO3 (1)	6	15	17
Hardness	mg/l as CaCO3 (0.02)	38	32	
Total Suspended Solids	mg/l (0.05)	0.5	11	
Ammonia	mg/l as N (0.03)	0.019	60	
Nitrate+Nitrite	mg/l as N (0.01)	0.022	54	
Total Kjeldahl Nitrogen	mg/l as N (0.06)	0.60	15	
Orthophosphorus	mg/l as P (0.01)	0.008	56	
Chloride	mg/l (0.05)	32	88	
Sulfate	mg/l (0.05)	35	85	
Sodium	mg/l (0.06)	19.3	91	
Potassium	mg/l (0.07)	2.4	39	
Calcium	mg/l (0.04)	11.3	44	
Magnesium	mg/l (0.006)	2.5	36	
Iron	ug/l (0.03)	22	26	

Based upon the average FTSI of 24, water quality is considered good. Little Moon Lake can be characterized as a clear (color<=10 color units), soft water, oligotrophic lake, with low concentrations of total phosphorus, low concentrations of total nitrogen. The chemical type of water (predominant ionic composition) is sodium chloride.

Also of note:

- Cattails dominate more than 30% of the lake shoreline.

Plots and Trends: No or insufficient data available for plotting or trend detection. Shown is a diagram of the relative ionic composition of the lake water.

MAJOR IONS (% meq/l)

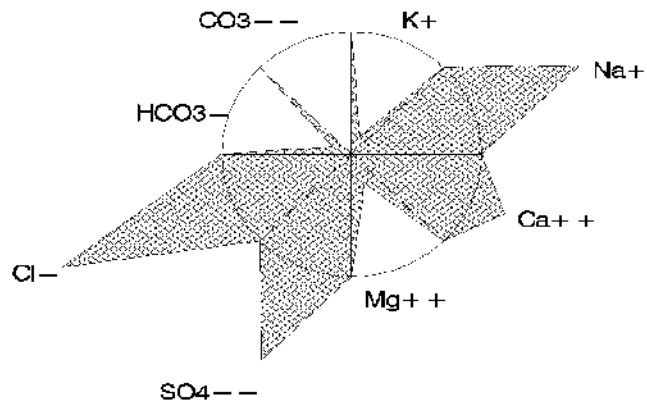

Little Moon Lake, Hillsborough County

Little Deer Lake

Hillsborough County

USGS Quadrangle: Lutz Major Land Use/Land Cover (1990)
 Section/Township/Range: 1-27S-18E within 500 meters of the lakeshore:
 Approx. Lake Center, Lat/Long: 280949/822756 - medium density residential (46%)
 Surface Area: 12 acres - cropland and pastureland (16%)
 Approx. Lake Elevation: 67 feet - other open lands - rural (13%)
 Lake Type: isolated (type 4)
 Major Basin: Tampa Bay Drainage
 Minor Basin: Drainage Canal
 Lake Region: Land-o-Lakes

Total Number of Samples Collected: 2 Most Recent Sample Collected: February 1997

Parameter	Units (Detection Limit)	Average Value	District Percentile	Florida Percentile
Chlorophyll a	ug/l (1)	8.6	59	34
Total Phosphorus	mg/l as P (0.01)	0.014	50	7
Total Nitrogen	mg/l as N (0.06)	0.62	12	16
Transparency (Secchi depth)	meters	2.25	70	89
Florida Trophic State Index		39	52	15
Specific Conductance	S/cm at 25C (1)	183	52	49
pH	standard units (0.1)	5.9	<5	7
Color	PtCo units (1)	8	24	8
Turbidity	NTU (1)	1.2	34	8
Total Alkalinity	mg/l as CaCO3 (1)	2	<5	5
Hardness	mg/l as CaCO3 (0.02)	45	46	
Total Suspended Solids	mg/l (0.05)	1.8	47	
Ammonia	mg/l as N (0.03)	0.015	60	
Nitrate+Nitrite	mg/l as N (0.01)	0.065	75	
Total Kjeldahl Nitrogen	mg/l as N (0.06)	0.55	11	
Orthophosphorus	mg/l as P (0.01)	0.008	56	
Chloride	mg/l (0.05)	16	37	
Sulfate	mg/l (0.05)	45	91	
Sodium	mg/l (0.06)	11.0	64	
Potassium	mg/l (0.07)	4.5	60	
Calcium	mg/l (0.04)	10.5	41	
Magnesium	mg/l (0.006)	4.5	63	
Iron	ug/l (0.03)	18	15	

Based upon the average FTSI of 39, water quality is considered good. Little Deer Lake can be characterized as a clear (color<=10 color units), soft water, meso-eutrophic lake, with low concentrations of total nitrogen. The chemical type of water (predominant ionic composition) is calcium sulfate.

Also of note:

- The measured pH was low.

Plots and Trends: No or insufficient data available for plotting or trend detection. Shown is a diagram of the relative ionic composition of the lake water.

MAJOR IONS (% meq/l)

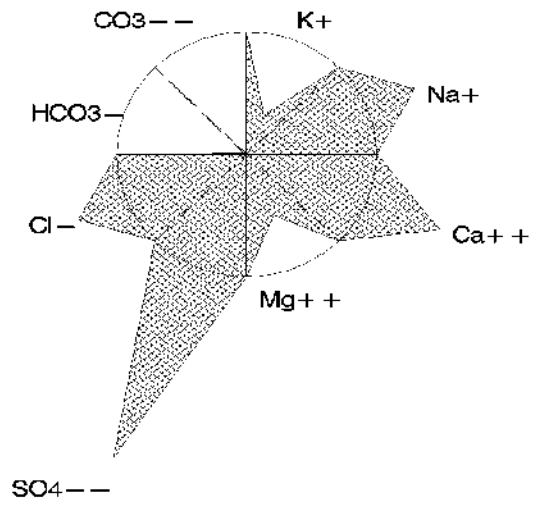

Long Pond Hillsborough County

USGS Quadrangle: Brandon Major Land Use/Land Cover (1990)
 Section/Township/Range: 13-29S-20E within 500 meters of the lakeshore:
 Approx. Lake Center, Lat/Long: 275756/821556 - medium density residential (38%)
 Surface Area: 52 acres - tree crops, typically citrus (17%)
 Approx. Lake Elevation: 47 feet - high density residential (14%)
 Lake Type: inflow and outflow (type 3)
 Major Basin: Hillsborough River
 Minor Basin: Selfer Canal
 Lake Region: Hillsborough Valley

Total Number of Samples Collected: 2 Most Recent Sample Collected: January 1996

Parameter	Units (Detection Limit)	Average Value	District Percentile	Florida Percentile
Chlorophyll a	ug/l (1)	8.3	58	34
Total Phosphorus	mg/l as P (0.01)	0.015	53	8
Total Nitrogen	mg/l as N (0.06)	0.72	19	21
Transparency (Secchi depth)	meters	2.10	67	87
Florida Trophic State Index		40	54	17
Specific Conductance	S/cm at 25C (1)	145	34	41
pH	standard units (0.1)	7.3	50	45
Color	PtCo units (1)	15	46	13
Turbidity	NTU (1)	0.9	28	<5
Total Alkalinity	mg/l as CaCO3 (1)	25	50	44
Hardness	mg/l as CaCO3 (0.02)	47	49	
Total Suspended Solids	mg/l (0.05)	1.8	47	
Ammonia	mg/l as N (0.03)	0.029	60	
Nitrate+Nitrite	mg/l as N (0.01)	0.012	40	
Total Kjeldahl Nitrogen	mg/l as N (0.06)	0.71	24	
Orthophosphorus	mg/l as P (0.01)	0.005	56	
Chloride	mg/l (0.05)	23	69	
Sulfate	mg/l (0.05)	8	31	
Sodium	mg/l (0.06)	7.9	43	
Potassium	mg/l (0.07)	2.6	42	
Calcium	mg/l (0.04)	11.5	46	
Magnesium	mg/l (0.006)	4.5	63	
Iron	ug/l (0.03)	41	54	

Based upon the average FTSI of 40, water quality is considered good. Long Pond can be characterized as a clear to moderately colored (10<color<20 color units), soft water, meso-eutrophic lake, with low concentrations of total nitrogen. The chemical type of water (predominant ionic composition) is calcium chloride.

Plots and Trends: Lake surface elevations in Long Pond were quite low at the beginning of the record, but have generally fluctuated through a range of approximately seven feet since then. Also shown is a diagram of the relative ionic composition of the lake water.

MONTHLY AVERAGE SURFACE ELEVATION

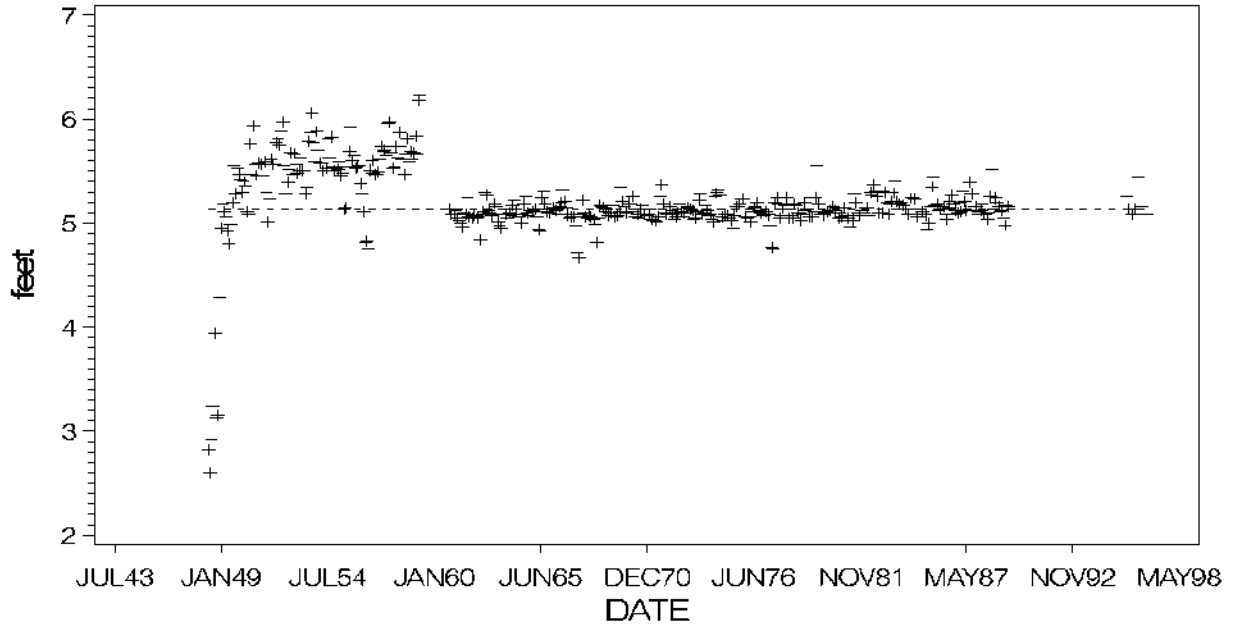

MAJOR IONS (% meq/l)

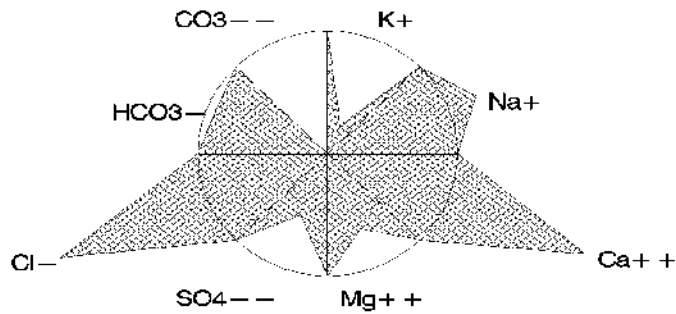

Lake Magdalene

Hillsborough County

USGS Quadrangle: Sulphur Springs Major Land Use/Land Cover (1990)
 Section/Township/Range: 2-28S-18E within 500 meters of the lakeshore:
 Approx. Lake Center, Lat/Long: 280453/822857 - medium density residential (35%)
 Surface Area: 238 acres - high density residential (32%)
 Approx. Lake Elevation: 50 feet - low density residential (10%)
 Average Depth: 7.5 feet
 (reference elevation 47 feet)
 Lake Type: inflow and outflow (type 3)
 Major Basin: Tampa Bay Drainage
 Minor Basin: Sweetwater Creek
 Lake Region: Land-o-Lakes

Total Number of Samples Collected: 2 Most Recent Sample Collected: February 1997

Parameter	Units (Detection Limit)	Average Value	District Percentile	Florida Percentile
Chlorophyll a	ug/l (1)	1.5	5	5
Total Phosphorus	mg/l as P (0.01)	0.009	31	<5
Total Nitrogen	mg/l as N (0.06)	0.96	37	32
Transparency (Secchi depth)	meters		-	-
Florida Trophic State Index		18	<5	<5
Specific Conductance	S/cm at 25C (1)	174	47	47
pH	standard units (0.1)	7.5	61	53
Color	PtCo units (1)	10	34	10
Turbidity	NTU (1)	1.0	29	5
Total Alkalinity	mg/l as CaCO3 (1)	35	66	53
Hardness	mg/l as CaCO3 (0.02)	54	55	
Total Suspended Solids	mg/l (0.05)	0.7	18	
Ammonia	mg/l as N (0.03)	0.015	60	
Nitrate+Nitrite	mg/l as N (0.01)	0.063	74	
Total Kjeldahl Nitrogen	mg/l as N (0.06)	0.90	39	
Orthophosphorus	mg/l as P (0.01)	0.005	56	
Chloride	mg/l (0.05)	21	61	
Sulfate	mg/l (0.05)	14	48	
Sodium	mg/l (0.06)	11.5	66	
Potassium	mg/l (0.07)	2.2	37	
Calcium	mg/l (0.04)	18.5	71	
Magnesium	mg/l (0.006)	2.0	25	
Iron	ug/l (0.03)	6	<5	

Based upon the average FTSI of 18, water quality is considered good. Lake Magdalene can be characterized as a clear (color<=10 color units), soft water, oligotrophic lake, with low concentrations of total phosphorus. The chemical type of water (predominant ionic composition) is calcium chloride.

Also of note:

- Melaleuca was observed on the lake shore.

Plots and Trends: Lake surface elevation has remained relatively stable over the long period of record. Measures of water chemistry generally show a wide range of variation for their periods of record. Recently collected samples had lower concentrations of sulfate than for the preceding period of record, and pH from 1975 to present seems to be higher than for the preceding period of record. Also shown is a diagram of the relative ionic composition of the lake water.

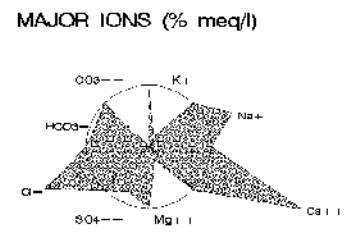
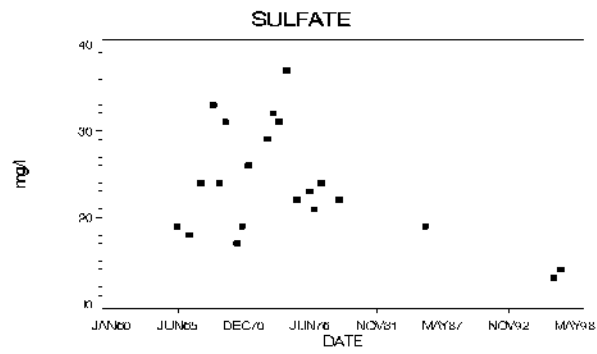
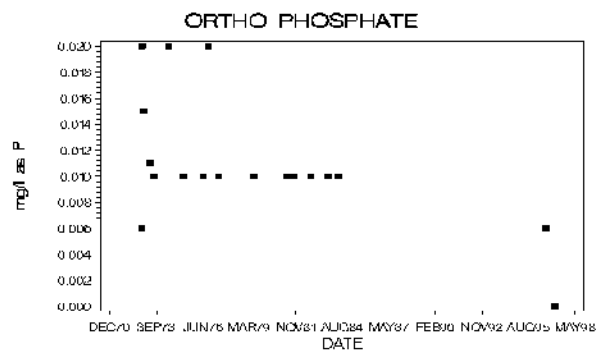
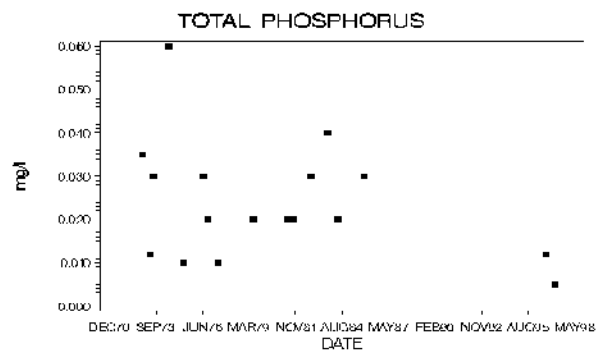
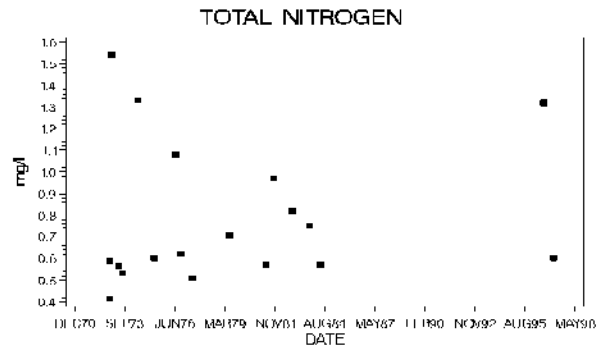
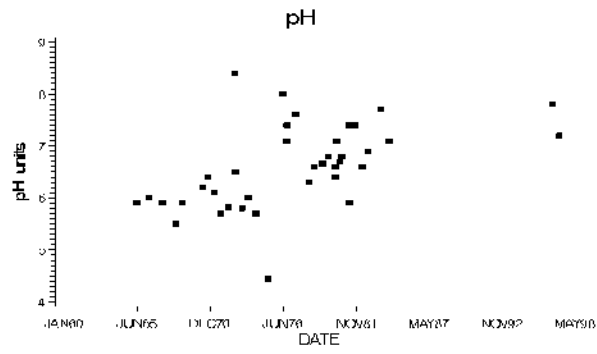
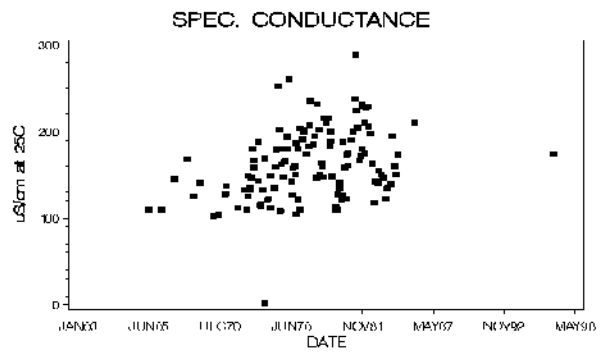
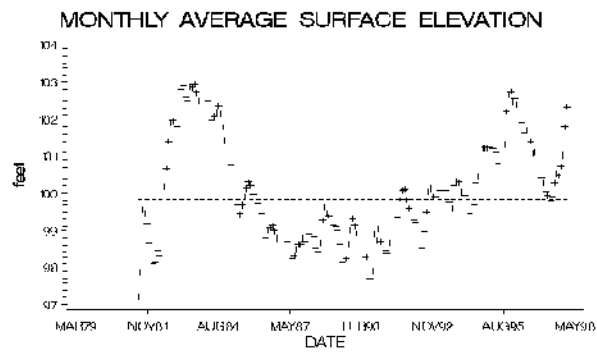

Lake Magdalene, Hillsborough County

Lake Mango

Hillsborough County

USGS Quadrangle: Brandon Major Land Use/Land Cover (1990)
 Section/Township/Range: 9-29S-20E within 500 meters of the lakeshore:
 Approx. Lake Center, Lat/Long: 275805/821808 - high density residential (43%)
 Surface Area: 30 acres - open land (19%)
 Approx. Lake Elevation: 29 feet - cropland and pastureland (10%)
 Lake Type: isolated (type 4)
 Major Basin: Tampa Bay Drainage
 Minor Basin: Mango Drain
 Lake Region: Hillsborough Valley

Total Number of Samples Collected: 2 Most Recent Sample Collected: January 1996

Parameter	Units (Detection Limit)	Average Value	District Percentile	Florida Percentile
Chlorophyll a	ug/l (1)	37.3	90	72
Total Phosphorus	mg/l as P (0.01)	0.066	91	48
Total Nitrogen	mg/l as N (0.06)	0.85	29	28
Transparency (Secchi depth)	meters	0.67	18	37
Florida Trophic State Index		65	90	65
Specific Conductance	S/cm at 25C (1)	122	21	32
pH	standard units (0.1)	7.2	43	40
Color	PtCo units (1)	65	83	55
Turbidity	NTU (1)	9.3	86	68
Total Alkalinity	mg/l as CaCO3 (1)	24	48	43
Hardness	mg/l as CaCO3 (0.02)	41	38	
Total Suspended Solids	mg/l (0.05)	11.3	92	
Ammonia	mg/l as N (0.03)	0.015	60	
Nitrate+Nitrite	mg/l as N (0.01)	0.005	33	
Total Kjeldahl Nitrogen	mg/l as N (0.06)	0.84	35	
Orthophosphorus	mg/l as P (0.01)	0.024	87	
Chloride	mg/l (0.05)	14	30	
Sulfate	mg/l (0.05)	8	31	
Sodium	mg/l (0.06)	7.5	39	
Potassium	mg/l (0.07)	2.6	42	
Calcium	mg/l (0.04)	12.0	48	
Magnesium	mg/l (0.006)	2.6	38	
Iron	ug/l (0.03)	314	>95	

Based upon the average FTSI of 65, water quality is considered fair. Lake Mango can be characterized as a colored, soft water, eutrophic lake, with high concentrations of total phosphorus. The chemical type of water (predominant ionic composition) is calcium chloride.

Plots and Trends: No or insufficient data available for plotting or trend detection. Shown is a diagram of the relative ionic composition of the lake water.

MAJOR IONS (% meq/l)

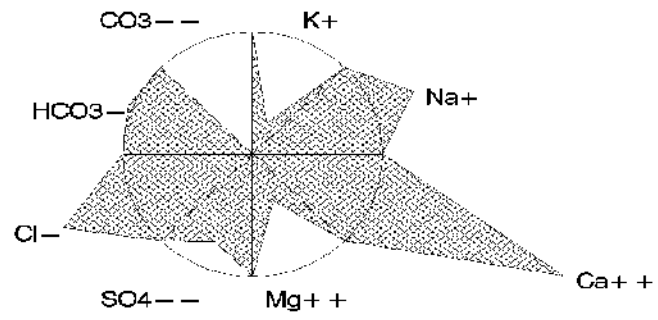

Marlee Lake

Hillsborough County

USGS Quadrangle: Citrus Park Major Land Use/Land Cover (1990)
 Section/Township/Range: 28-27S-17E within 500 meters of the lakeshore:
 Approx. Lake Center, Lat/Long: 280559/823630 - tree crops, typically citrus (25%)
 Surface Area: 12 acres - medium density residential (18%)
 Approx. Lake Elevation: 32 feet - other open lands - rural (14%)
 Lake Type: isolated (type 4)
 Major Basin: Tampa Bay Drainage
 Minor Basin: Double Branch
 Lake Region: Keystone Lakes

Total Number of Samples Collected: 2 Most Recent Sample Collected: January 1996

Parameter	Units (Detection Limit)	Average Value	District Percentile	Florida Percentile
Chlorophyll a	ug/l (1)	1.5	5	5
Total Phosphorus	mg/l as P (0.01)	0.008	31	<5
Total Nitrogen	mg/l as N (0.06)	0.61	9	16
Transparency (Secchi depth)	meters	2.98	83	>95
Florida Trophic State Index		22	9	<5
Specific Conductance	S/cm at 25C (1)	174	47	47
pH	standard units (0.1)	6.9	29	28
Color	PtCo units (1)	28	65	22
Turbidity	NTU (1)	1.0	29	5
Total Alkalinity	mg/l as CaCO3 (1)	11	29	27
Hardness	mg/l as CaCO3 (0.02)	46	48	
Total Suspended Solids	mg/l (0.05)	0.3	<5	
Ammonia	mg/l as N (0.03)	0.102	87	
Nitrate+Nitrite	mg/l as N (0.01)	0.092	81	
Total Kjeldahl Nitrogen	mg/l as N (0.06)	0.52	9	
Orthophosphorus	mg/l as P (0.01)	0.009	56	
Chloride	mg/l (0.05)	19	51	
Sulfate	mg/l (0.05)	34	83	
Sodium	mg/l (0.06)	10.0	58	
Potassium	mg/l (0.07)	3.0	46	
Calcium	mg/l (0.04)	11.0	43	
Magnesium	mg/l (0.006)	4.4	61	
Iron	ug/l (0.03)	56	65	

Based upon the average FTSI of 22, water quality is considered good. Marlee Lake can be characterized as a moderately colored, soft water, oligotrophic lake, with low concentrations of total phosphorus, low concentrations of total nitrogen. The chemical type of water (predominant ionic composition) is calcium sulfate.

Plots and Trends: No or insufficient data available for plotting or trend detection. Shown is a diagram of the relative ionic composition of the lake water.

MAJOR IONS (% meq/l)

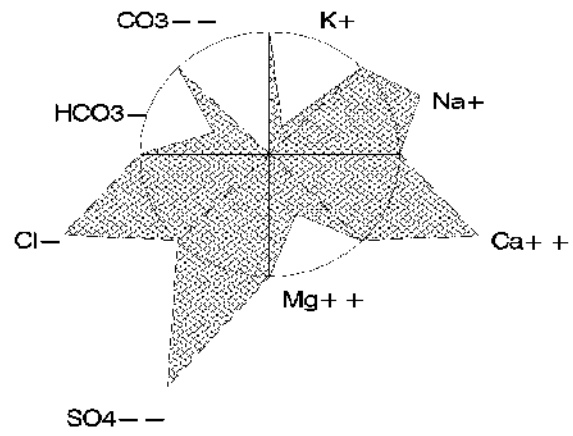

Mead Lake

Hillsborough County

USGS Quadrangle: Brandon Major Land Use/Land Cover (1990)
 Section/Township/Range: 22-29S-20E within 500 meters of the lakeshore:
 Approx. Lake Center, Lat/Long: 275652/821742 - high density residential (30%)
 Surface Area: 14 acres - medium density residential (25%)
 Approx. Lake Elevation: 29 feet - freshwater marshes (18%)
 Lake Type: isolated (type 4)
 Major Basin: Tampa Bay Drainage
 Minor Basin: Delaney Creek
 Lake Region: Hillsborough Valley

Total Number of Samples Collected: 2 Most Recent Sample Collected: January 1996

Parameter	Units (Detection Limit)	Average Value	District Percentile	Florida Percentile
Chlorophyll a	ug/l (1)	3.3	28	14
Total Phosphorus	mg/l as P (0.01)	0.030	77	20
Total Nitrogen	mg/l as N (0.06)	0.74	21	22
Transparency (Secchi depth)	meters	1.90	61	83
Florida Trophic State Index		36	44	10
Specific Conductance	S/cm at 25C (1)	83	9	16
pH	standard units (0.1)	6.7	21	23
Color	PtCo units (1)	55	80	45
Turbidity	NTU (1)	0.5	28	<5
Total Alkalinity	mg/l as CaCO3 (1)	17	39	35
Hardness	mg/l as CaCO3 (0.02)	25	14	
Total Suspended Solids	mg/l (0.05)	0.7	18	
Ammonia	mg/l as N (0.03)	0.035	66	
Nitrate+Nitrite	mg/l as N (0.01)	0.009	33	
Total Kjeldahl Nitrogen	mg/l as N (0.06)	0.73	27	
Orthophosphorus	mg/l as P (0.01)	0.010	59	
Chloride	mg/l (0.05)	12	23	
Sulfate	mg/l (0.05)	2	10	
Sodium	mg/l (0.06)	6.1	23	
Potassium	mg/l (0.07)	2.6	42	
Calcium	mg/l (0.04)	7.7	27	
Magnesium	mg/l (0.006)	1.3	12	
Iron	ug/l (0.03)	79	74	

Based upon the average FTSI of 36, water quality is considered good. Mead Lake can be characterized as a colored, soft water, oligo-mesotrophic lake, with low concentrations of total nitrogen. The chemical type of water (predominant ionic composition) is calcium chloride.

Plots and Trends: No or insufficient data available for plotting or trend detection. Shown is a diagram of the relative ionic composition of the lake water.

MAJOR IONS (% meq/l)

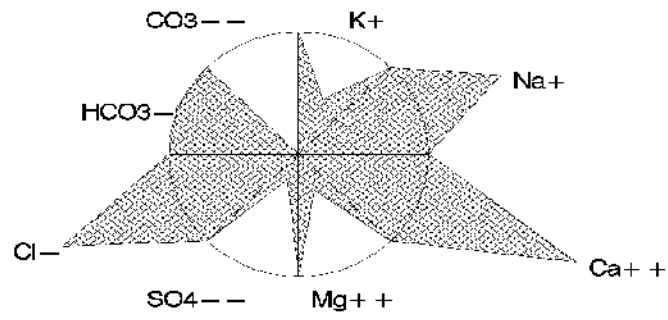

Mead Lake, Hillsborough County

Lake Merrywater Hillsborough County

USGS Quadrangle: Sulphur Springs Major Land Use/Land Cover (1990)
 Section/Township/Range: 22-27S-18E within 500 meters of the lakeshore:
 Approx. Lake Center, Lat/Long: 280723/822914 - cropland and pastureland (39%)
 Surface Area: 25 acres - low density residential (14%)
 Approx. Lake Elevation: 57 feet - tree crops, typically citrus (12%)
 Average Depth: 7.4 feet
 Observed Maximum Depth: 14.8 feet
 (reference elevation 55.8 feet)
 Lake Type: inflow and outflow (type 3)
 Major Basin: Tampa Bay Drainage
 Minor Basin: Drainage Canal
 Lake Region: Land-o-Lakes

Total Number of Samples Collected: 2 Most Recent Sample Collected: January 1995

Parameter	Units (Detection Limit)	Average Value	District Percentile	Florida Percentile
Chlorophyll a	ug/l (1)	49.2	94	81
Total Phosphorus	mg/l as P (0.01)	0.036	81	26
Total Nitrogen	mg/l as N (0.06)	1.99	84	81
Transparency (Secchi depth)	meters	0.55	13	25
Florida Trophic State Index		69	94	77
Specific Conductance	S/cm at 25C (1)	197	58	51
pH	standard units (0.1)	7.2	43	40
Color	PtCo units (1)	20	55	17
Turbidity	NTU (1)	7.9	83	63
Total Alkalinity	mg/l as CaCO3 (1)	10	27	25
Hardness	mg/l as CaCO3 (0.02)	58	60	
Total Suspended Solids	mg/l (0.05)	10.0	90	
Ammonia	mg/l as N (0.03)	0.023	60	
Nitrate+Nitrite	mg/l as N (0.01)	0.005	33	
Total Kjeldahl Nitrogen	mg/l as N (0.06)	1.98	90	
Orthophosphorus	mg/l as P (0.01)	0.021	86	
Chloride	mg/l (0.05)	18	46	
Sulfate	mg/l (0.05)	43	90	
Sodium	mg/l (0.06)	7.9	43	
Potassium	mg/l (0.07)	6.6	79	
Calcium	mg/l (0.04)	14.5	58	
Magnesium	mg/l (0.006)	5.3	72	
Iron	ug/l (0.03)	47	59	

Based upon the average FTSI of 69, water quality is considered fair. Lake Merrywater can be characterized as a moderately colored, soft water, eutrophic to hypereutrophic lake, with high concentrations of total phosphorus and high concentrations of total nitrogen. The chemical type of water (predominant ionic composition) is calcium sulfate.

Plots and Trends: No or insufficient data available for plotting or trend detection. Shown is a diagram of the relative ionic composition of the lake water.

MAJOR IONS (% meq/l)

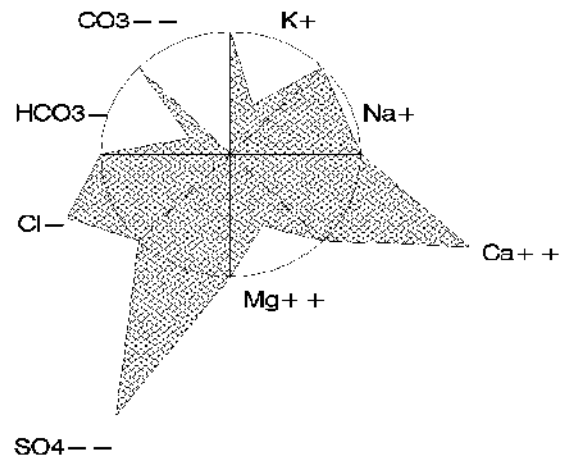

Platt Lake

Hillsborough County

USGS Quadrangle: Sulphur Springs Major Land Use/Land Cover (1990)
 Section/Township/Range: 35-27S-18E within 500 meters of the lakeshore:
 Approx. Lake Center, Lat/Long: 280540/822844 - medium density residential (35%)
 Surface Area: 63 acres - low density residential (27%)
 Approx. Lake Elevation: 51 feet - tree crops, typically citrus (7%)
 Lake Type: inflow and outflow (type 3)
 Major Basin: Tampa Bay Drainage
 Minor Basin: Sweetwater Creek
 Lake Region: Land-o-Lakes

Total Number of Samples Collected: 2 Most Recent Sample Collected: January 1995

Parameter	Units (Detection Limit)	Average Value	District Percentile	Florida Percentile
Chlorophyll a	ug/l (1)	3.0	25	13
Total Phosphorus	mg/l as P (0.01)	0.012	41	6
Total Nitrogen	mg/l as N (0.06)	0.91	33	30
Transparency (Secchi depth)	meters	2.10	67	87
Florida Trophic State Index		35	43	10
Specific Conductance	S/cm at 25C (1)	103	13	24
pH	standard units (0.1)	7.7	69	60
Color	PtCo units (1)	23	58	19
Turbidity	NTU (1)	0.5	28	<5
Total Alkalinity	mg/l as CaCO3 (1)	10	27	25
Hardness	mg/l as CaCO3 (0.02)	31	23	
Total Suspended Solids	mg/l (0.05)	0.7	18	
Ammonia	mg/l as N (0.03)	0.015	60	
Nitrate+Nitrite	mg/l as N (0.01)	0.018	48	
Total Kjeldahl Nitrogen	mg/l as N (0.06)	0.89	38	
Orthophosphorus	mg/l as P (0.01)	0.005	56	
Chloride	mg/l (0.05)	13	27	
Sulfate	mg/l (0.05)	9	34	
Sodium	mg/l (0.06)	6.5	27	
Potassium	mg/l (0.07)	0.4	9	
Calcium	mg/l (0.04)	9.3	36	
Magnesium	mg/l (0.006)	1.8	22	
Iron	ug/l (0.03)	47	59	

Based upon the average FTSI of 35, water quality is considered good. Platt Lake can be characterized as a moderately colored, soft water, oligo-mesotrophic lake. The chemical type of water (predominant ionic composition) is calcium chloride.

Plots and Trends: Lake surface elevations from 1970 to present appears similar to elevations during the mid-1940s to the mid-1950s. Also shown is a diagram of the relative ionic composition of the lake water.

MONTHLY AVERAGE SURFACE ELEVATION

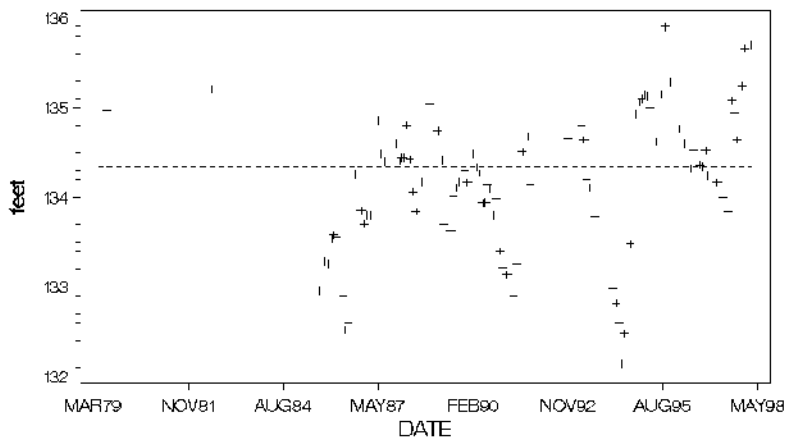

SPEC. CONDUCTANCE

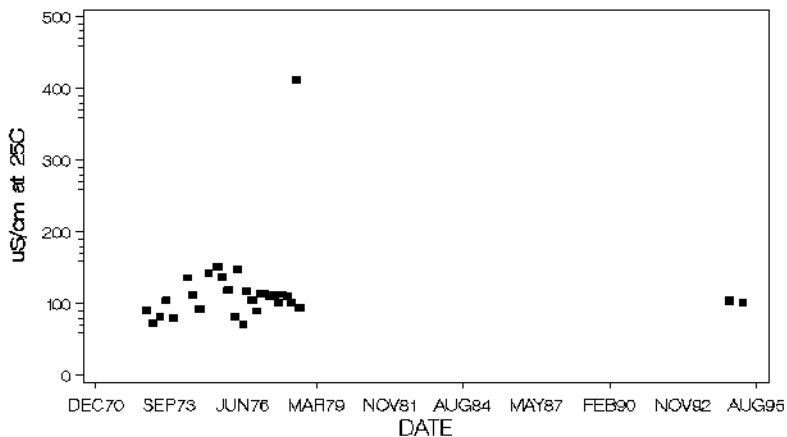

MAJOR IONS (% meq/l)

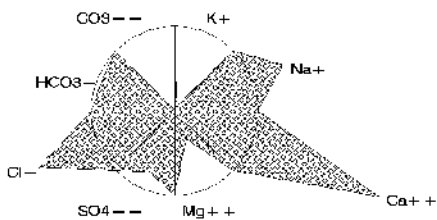

Platt Lake, Hillsborough County

Pretty Lake Hillsborough County

USGS Quadrangle: Citrus Park Major Land Use/Land Cover (1990)
 Section/Township/Range: 26-27S-17E within 500 meters of the lakeshore:
 Approx. Lake Center, Lat/Long: 280626/823404 - other open lands - rural (21%)
 Surface Area: 80 acres - medium density residential (20%)
 Approx. Lake Elevation: 46 feet - cropland and pastureland (15%)
 Lake Type: inflow and outflow (type 3)
 Major Basin: Tampa Bay Drainage
 Minor Basin: Lower Rocky Creek
 Lake Region: Tampa Plain

Total Number of Samples Collected: 2 Most Recent Sample Collected: January 1995

Parameter	Units (Detection Limit)	Average Value	District Percentile	Florida Percentile
Chlorophyll a	ug/l (1)	2.2	14	9
Total Phosphorus	mg/l as P (0.01)	0.015	53	8
Total Nitrogen	mg/l as N (0.06)	1.50	69	60
Transparency (Secchi depth)	meters	1.88	60	83
Florida Trophic State Index		34	37	8
Specific Conductance	S/cm at 25C (1)	124	22	33
pH	standard units (0.1)	6.4	12	15
Color	PtCo units (1)	95	89	75
Turbidity	NTU (1)	1.5	41	13
Total Alkalinity	mg/l as CaCO3 (1)	17	39	35
Hardness	mg/l as CaCO3 (0.02)	34	27	
Total Suspended Solids	mg/l (0.05)	0.6	15	
Ammonia	mg/l as N (0.03)	0.015	60	
Nitrate+Nitrite	mg/l as N (0.01)	0.052	70	
Total Kjeldahl Nitrogen	mg/l as N (0.06)	1.45	77	
Orthophosphorus	mg/l as P (0.01)	0.005	56	
Chloride	mg/l (0.05)	26	78	
Sulfate	mg/l (0.05)	15	50	
Sodium	mg/l (0.06)	11.9	67	
Potassium	mg/l (0.07)	4.0	56	
Calcium	mg/l (0.04)	9.4	37	
Magnesium	mg/l (0.006)	2.6	38	
Iron	ug/l (0.03)	177	91	

Based upon the average FTSI of 34, water quality is considered good. Pretty Lake can be characterized as a highly colored, soft water, oligo-mesotrophic lake. The chemical type of water (predominant ionic composition) is calcium chloride (1 sample) or sodium chloride (1 sample).

Plots and Trends: Shown are plots of lake surface elevation and specific conductance, and a diagram of the relative ionic composition of the lake water. There is no significant trend for annual median lake surface elevation for Pretty Lake (p=0.95, Sen's slope estimator). There has been no detectable change in specific conductance.

MONTHLY AVERAGE SURFACE ELEVATION

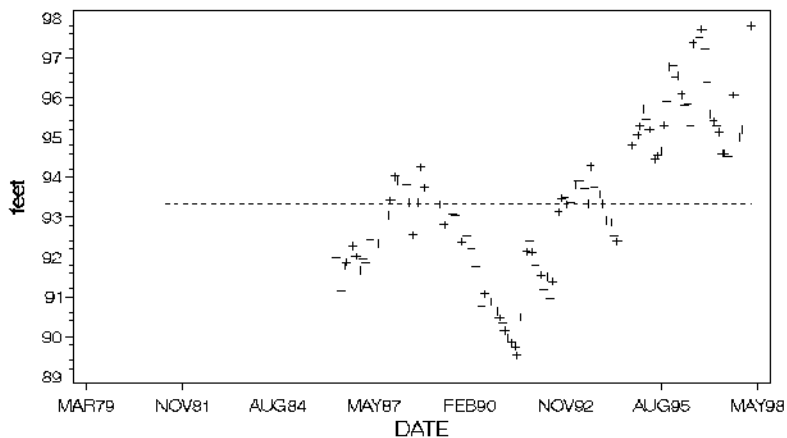

SPEC. CONDUCTANCE

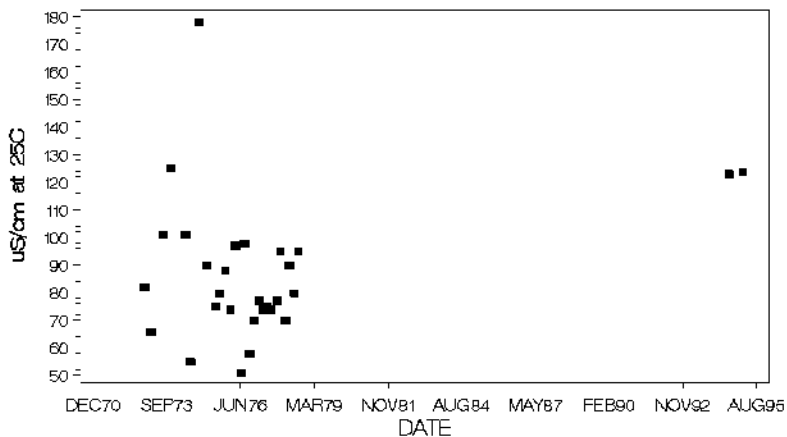

MAJOR IONS (% meq/l)

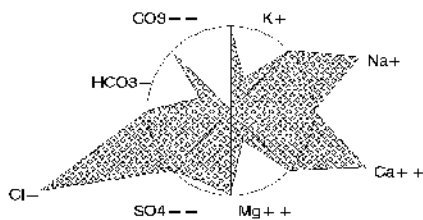

Pretty Lake, Hillsborough County

Rainbow Lake

Hillsborough County

USGS Quadrangle: Citrus Park Major Land Use/Land Cover (1990)
 Section/Township/Range: 22-27S-17E within 500 meters of the lakeshore:
 Approx. Lake Center, Lat/Long: 280657/823547 - medium density residential (51%)
 Surface Area: 47 acres - cropland and pastureland (10%)
 Approx. Lake Elevation: 41 feet - hardwood - conifer mixed (9%)
 Average Depth: 8.9 feet
 Observed Maximum Depth: 19.1 feet
 (reference elevation 39.1 feet)
 Lake Type: inflow and outflow (type 3)
 Major Basin: Tampa Bay Drainage
 Minor Basin: Unnamed Ditch
 Lake Region: Keystone Lakes

Total Number of Samples Collected: 2 Most Recent Sample Collected: January 1996

Parameter	Units (Detection Limit)	Average Value	District Percentile	Florida Percentile
Chlorophyll a	ug/l (1)	3.3	28	14
Total Phosphorus	mg/l as P (0.01)	0.009	31	<5
Total Nitrogen	mg/l as N (0.06)	1.33	62	47
Transparency (Secchi depth)	meters	2.80	81	94
Florida Trophic State Index		26	20	<5
Specific Conductance	S/cm at 25C (1)	142	32	40
pH	standard units (0.1)	6.8	25	25
Color	PtCo units (1)	10	34	10
Turbidity	NTU (1)	0.5	28	<5
Total Alkalinity	mg/l as CaCO3 (1)	10	27	25
Hardness	mg/l as CaCO3 (0.02)	31	23	
Total Suspended Solids	mg/l (0.05)	0.8	21	
Ammonia	mg/l as N (0.03)	0.108	89	
Nitrate+Nitrite	mg/l as N (0.01)	0.005	33	
Total Kjeldahl Nitrogen	mg/l as N (0.06)	1.33	70	
Orthophosphorus	mg/l as P (0.01)	0.005	56	
Chloride	mg/l (0.05)	22	64	
Sulfate	mg/l (0.05)	19	58	
Sodium	mg/l (0.06)	14.5	82	
Potassium	mg/l (0.07)	0.5	11	
Calcium	mg/l (0.04)	8.5	30	
Magnesium	mg/l (0.006)	2.4	35	
Iron	ug/l (0.03)	41	54	

Based upon the average FTSI of 26, water quality is considered good. Rainbow Lake can be characterized as a clear (color<=10 color units), soft water, oligo-mesotrophic lake, with low concentrations of total phosphorus. The chemical type of water (predominant ionic composition) is sodium chloride.

Also of note:

- Melaleuca and Hydrilla were observed.

Plots and Trends: The large dip in the lake surface elevation in the mid-1990s is typical of many lakes in the Northwest Hillsborough region. Nearly two-thirds of the lakes sampled in the area had the lowest elevations for their individual periods of record between 1991 and 1995. Recent measures of conductivity were similar to those measured during the 1970s. Also shown is a diagram of the relative ionic composition of the lake water.

MONTHLY AVERAGE SURFACE ELEVATION

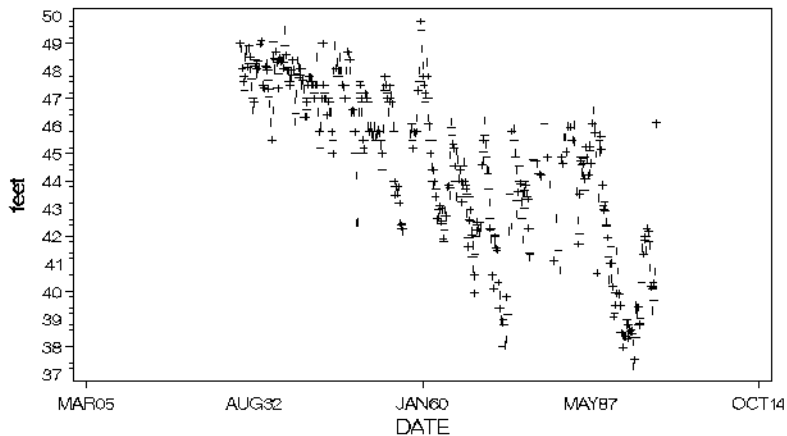

SPEC. CONDUCTANCE

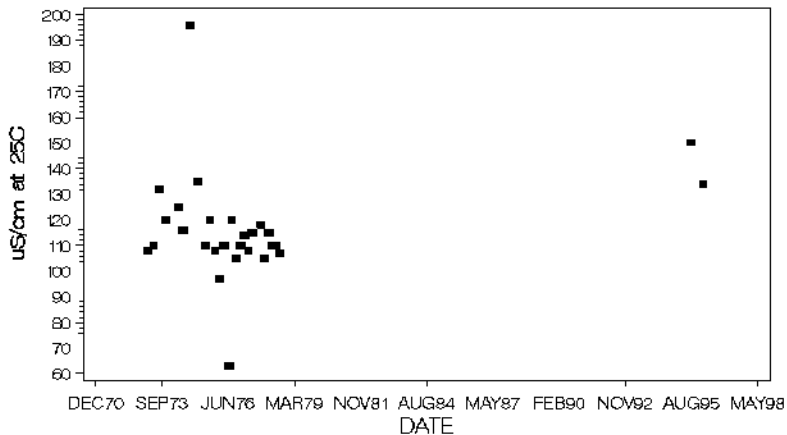

MAJOR IONS (% meq/l)

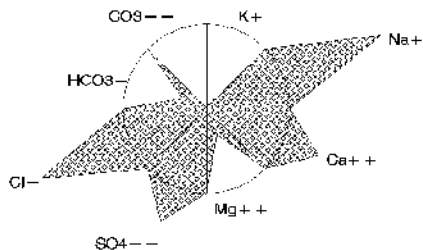

Rainbow Lake, Hillsborough County

Lake Raleigh Hillsborough County

USGS Quadrangle:	Citrus Park	Major Land Use/Land Cover (1990)
Section/Township/Range:	27-27S-17E	within 500 meters of the lakeshore:
Approx. Lake Center, Lat/Long:	280620/823503	- hardwood - conifer mixed (38%)
Surface Area:	24 acres	- institutional (17%)
Approx. Lake Elevation:	45 feet	- wet prairies (15%)

Average Depth: 10.7 feet
 Observed Maximum Depth: 25.6 feet
 (reference elevation 44.6 feet)
 Lake Type: isolated (type 4)
 Major Basin: Tampa Bay Drainage
 Minor Basin: Double Branch
 Lake Region: Keystone Lakes

Total Number of Samples Collected: 2 Most Recent Sample Collected: January 1995

Parameter	Units (Detection Limit)	Average Value	District Percentile	Florida Percentile
Chlorophyll a	ug/l (1)	2.4	17	10
Total Phosphorus	mg/l as P (0.01)	0.009	31	<5
Total Nitrogen	mg/l as N (0.06)	0.77	25	24
Transparency (Secchi depth)	meters	3.15	87	>95
Florida Trophic State Index		31	32	6
Specific Conductance	S/cm at 25C (1)	172	46	47
pH	standard units (0.1)	5.6	<5	<5
Color	PtCo units (1)	33	69	25
Turbidity	NTU (1)	1.7	45	16
Total Alkalinity	mg/l as CaCO3 (1)	1	<5	<5
Hardness	mg/l as CaCO3 (0.02)	52	54	
Total Suspended Solids	mg/l (0.05)	1.4	37	
Ammonia	mg/l as N (0.03)	0.015	60	
Nitrate+Nitrite	mg/l as N (0.01)	0.005	33	
Total Kjeldahl Nitrogen	mg/l as N (0.06)	0.77	31	
Orthophosphorus	mg/l as P (0.01)	0.005	56	
Chloride	mg/l (0.05)	12	23	
Sulfate	mg/l (0.05)	52	93	
Sodium	mg/l (0.06)	6.8	31	
Potassium	mg/l (0.07)	0.4	9	
Calcium	mg/l (0.04)	14.5	58	
Magnesium	mg/l (0.006)	3.6	54	
Iron	ug/l (0.03)	23	27	

Based upon the average FTSI of 31, water quality is considered good. Lake Raleigh can be characterized as a moderately colored, soft water, oligo-mesotrophic lake, with low concentrations of total phosphorus. The chemical type of water (predominant ionic composition) is calcium sulfate.

Also of note:

- The measured pH was low.

Plots and Trends: Lake Raleigh is situated in the Cosme-Odessa Wellfield in northwestern Hillsborough County. The depressed lake elevations that have occurred since the early 1960s, shown in the lake elevation plot, are likely due to groundwater withdrawals. The total range of fluctuation in lake level is approximately 17 feet. Also shown is a diagram of the relative ionic composition of the lake water.

MONTHLY AVERAGE SURFACE ELEVATION

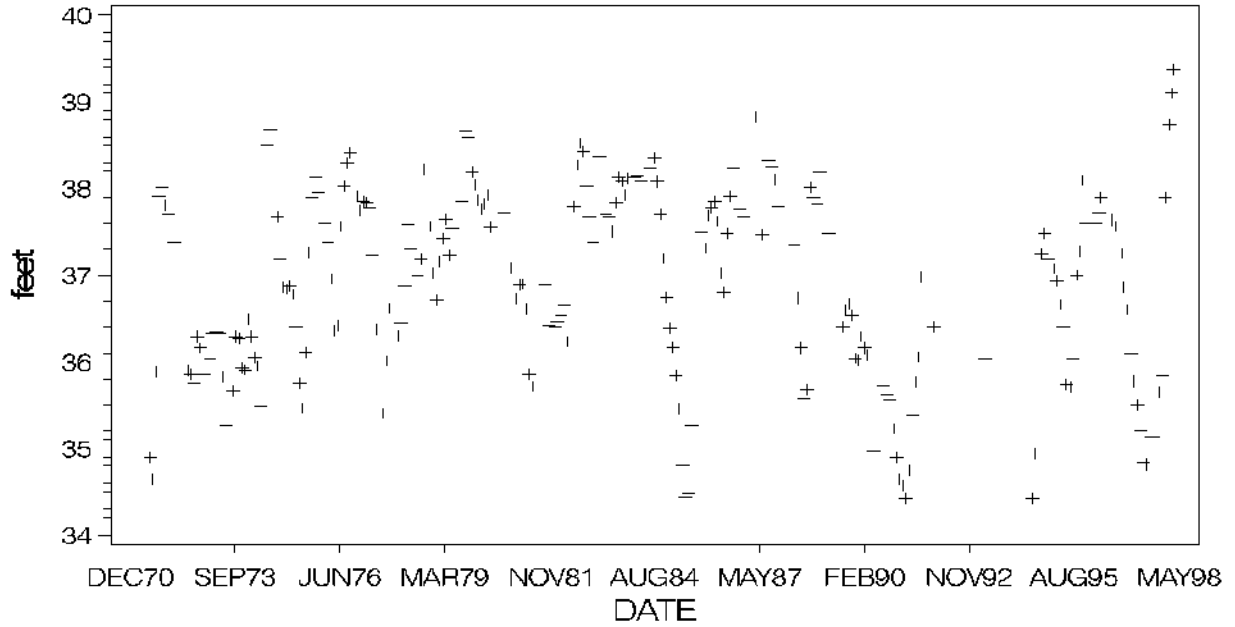

MAJOR IONS (% meq/l)

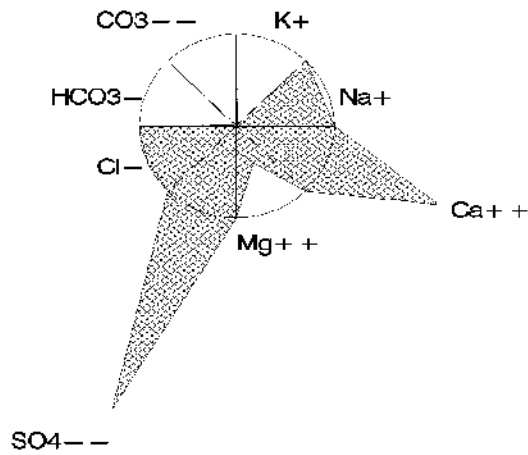

Lake Reinheimer Hillsborough County

USGS Quadrangle: Lutz Major Land Use/Land Cover (1990)
 Section/Township/Range: 15-27S-18E within 500 meters of the lakeshore:
 Approx. Lake Center, Lat/Long: 280747/822913 - cropland and pastureland (46%)
 Surface Area: 23 acres - medium density residential (26%)
 Approx. Lake Elevation: 60 feet - cypress (10%)
 Average Depth: 3.5 feet
 Observed Maximum Depth: 16.5 feet
 (reference elevation 59.5 feet)
 Lake Type: inflow and outflow (type 3)
 Major Basin: Tampa Bay Drainage
 Minor Basin: Drainage Canal
 Lake Region: Land-o-Lakes

Total Number of Samples Collected: 2 Most Recent Sample Collected: January 1995

Parameter	Units (Detection Limit)	Average Value	District Percentile	Florida Percentile
Chlorophyll a	ug/l (1)	11.2	68	40
Total Phosphorus	mg/l as P (0.01)	0.019	63	10
Total Nitrogen	mg/l as N (0.06)	2.55	91	88
Transparency (Secchi depth)	meters	1.20	40	70
Florida Trophic State Index		47	67	28
Specific Conductance	S/cm at 25C (1)	240	75	58
pH	standard units (0.1)	5.9	<5	7
Color	PtCo units (1)	8	24	8
Turbidity	NTU (1)	2.1	53	21
Total Alkalinity	mg/l as CaCO3 (1)	1	<5	<5
Hardness	mg/l as CaCO3 (0.02)	63	65	
Total Suspended Solids	mg/l (0.05)	3.6	69	
Ammonia	mg/l as N (0.03)	1.082	>95	
Nitrate+Nitrite	mg/l as N (0.01)	0.040	65	
Total Kjeldahl Nitrogen	mg/l as N (0.06)	2.50	>95	
Orthophosphorus	mg/l as P (0.01)	0.005	56	
Chloride	mg/l (0.05)	18	46	
Sulfate	mg/l (0.05)	34	83	
Sodium	mg/l (0.06)	10.2	59	
Potassium	mg/l (0.07)	3.9	54	
Calcium	mg/l (0.04)	15.0	60	
Magnesium	mg/l (0.006)	6.2	77	
Iron	ug/l (0.03)	104	83	

Based upon the average FTSI of 47, water quality is considered good. Lake Reinheimer can be characterized as a clear (color<=10 color units), medium hard water, meso-eutrophic lake, with high concentrations of total nitrogen. The chemical type of water (predominant ionic composition) is calcium chloride (1 sample) or calcium sulfate (1 sample).

Also of note:

- The measured pH was low.

Plots and Trends: No or insufficient data available for plotting or trend detection. Shown is a diagram of the relative ionic composition of the lake water.

MAJOR IONS (% meq/l)

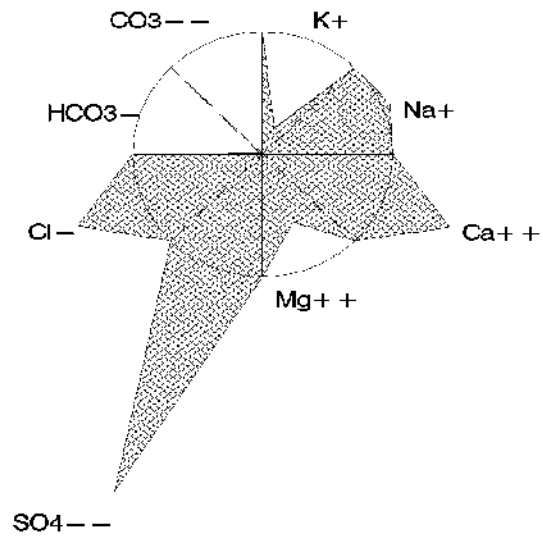

Lake Rogers Hillsborough County

USGS Quadrangle:	Citrus Park	Major Land Use/Land Cover (1990)
Section/Township/Range:	27-27S-17E	within 500 meters of the lakeshore:
Approx. Lake Center, Lat/Long:	280631/823520	- hardwood - conifer mixed (55%)
Surface Area:	93 acres	- wet prairies (11%)
Approx. Lake Elevation:	45 feet	- medium density residential (7%)
Average Depth: 13.7 feet		
Observed Maximum Depth: 28.6 feet		
(reference elevation 44.6 feet)		
Lake Type: isolated (type 4)		
Major Basin: Tampa Bay Drainage		
Minor Basin: Double Branch		
Lake Region: Keystone Lakes		

Total Number of Samples Collected: 2 Most Recent Sample Collected: January 1996

Parameter	Units (Detection Limit)	Average Value	District Percentile	Florida Percentile
Chlorophyll a	ug/l (1)	0.8	<5	<5
Total Phosphorus	mg/l as P (0.01)	0.008	31	<5
Total Nitrogen	mg/l as N (0.06)	0.89	31	30
Transparency (Secchi depth)	meters	3.30	89	>95
Florida Trophic State Index		8	<5	<5
Specific Conductance	S/cm at 25C (1)	147	36	41
pH	standard units (0.1)	6.2	8	10
Color	PtCo units (1)	5	9	5
Turbidity	NTU (1)	0.5	28	<5
Total Alkalinity	mg/l as CaCO3 (1)	7	18	20
Hardness	mg/l as CaCO3 (0.02)	44	43	
Total Suspended Solids	mg/l (0.05)	0.4	8	
Ammonia	mg/l as N (0.03)	0.051	75	
Nitrate+Nitrite	mg/l as N (0.01)	0.005	33	
Total Kjeldahl Nitrogen	mg/l as N (0.06)	0.88	37	
Orthophosphorus	mg/l as P (0.01)	0.008	56	
Chloride	mg/l (0.05)	10	15	
Sulfate	mg/l (0.05)	42	89	
Sodium	mg/l (0.06)	6.5	27	
Potassium	mg/l (0.07)	0.3	7	
Calcium	mg/l (0.04)	13.0	53	
Magnesium	mg/l (0.006)	2.8	41	
Iron	ug/l (0.03)	29	36	

Based upon the average FTSI of 8, water quality is considered good. Lake Rogers can be characterized as a clear (color<=10 color units), soft water, oligotrophic lake, with low concentrations of total phosphorus. The chemical type of water (predominant ionic composition) is calcium sulfate.

Plots and Trends: Lake Rogers is situated in the Cosme-Odessa Wellfield in northwestern Hillsborough County. The depressed lake elevations that have occurred since the early 1960s, shown in the lake elevation plot, are likely due to groundwater withdrawals. The total range of fluctuation in lake level is approximately 18 feet. Also shown is a diagram of the relative ionic composition of the lake water.

MONTHLY AVERAGE SURFACE ELEVATION

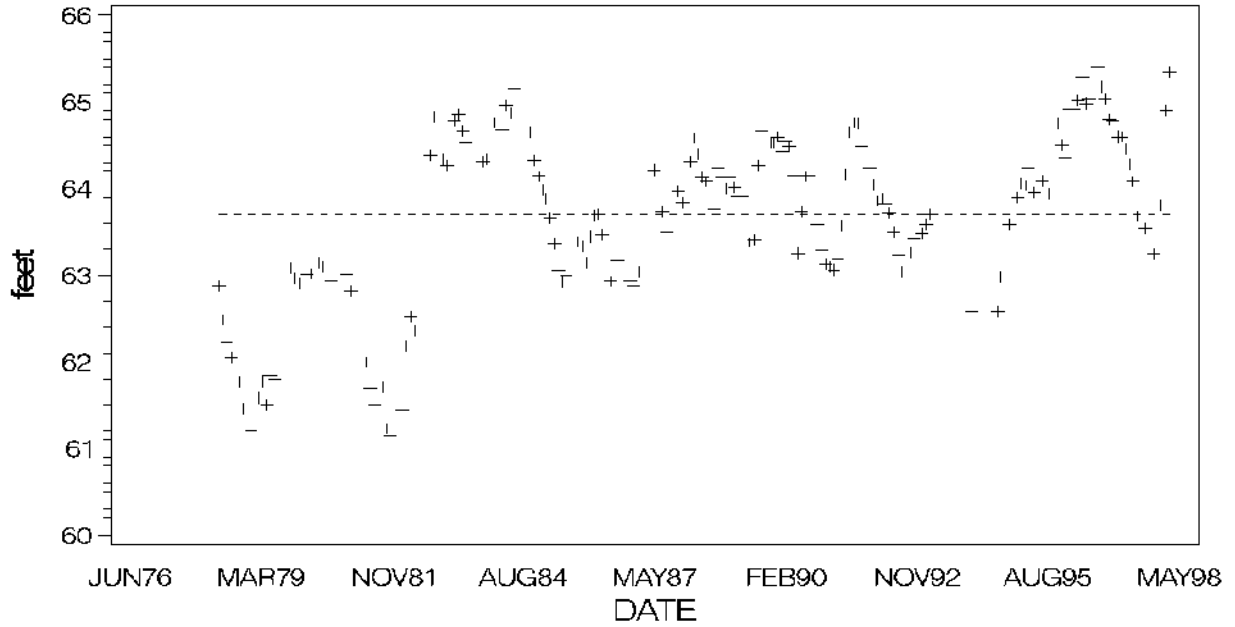

MAJOR IONS (% meq/l)

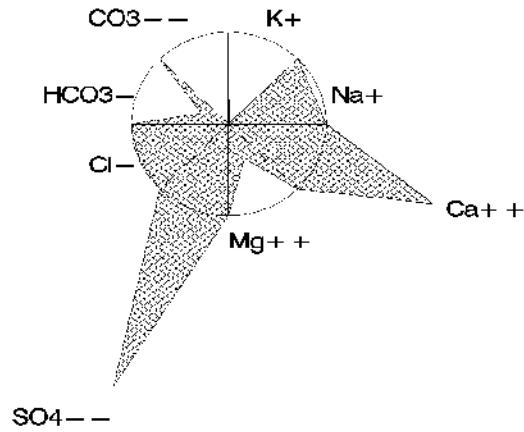

Round Lake Hillsborough County

USGS Quadrangle:	Citrus Park	Major Land Use/Land Cover (1990)
Section/Township/Range:	22-27S-18E	within 500 meters of the lakeshore:
Approx. Lake Center, Lat/Long:	280714/823001	- medium density residential (41%)
Surface Area:	19 acres	- wetland forested mixed (17%)
Approx. Lake Elevation:	58 feet	- open land (12%)
Average Depth: 6.2 feet		
Observed Maximum Depth: 14.6 feet		
(reference elevation 55.6 feet)		
Lake Type: outflow (type 2)		
Major Basin: Tampa Bay Drainage		
Minor Basin: Drainage Canal		
Lake Region: Land-o-Lakes		

Total Number of Samples Collected: 8 Most Recent Sample Collected: May 1997

Parameter	Units (Detection Limit)	Average Value	District Percentile	Florida Percentile
Chlorophyll a	ug/l (1)	2.3	15	10
Total Phosphorus	mg/l as P (0.01)	0.006	31	<5
Total Nitrogen	mg/l as N (0.06)	0.39	<5	<5
Transparency (Secchi depth)	meters	3.00	84	>95
Florida Trophic State Index		26	17	<5
Specific Conductance	S/cm at 25C (1)	225	68	56
pH	standard units (0.1)	7.7	69	60
Color	PtCo units (1)	9	30	9
Turbidity	NTU (1)	0.6	28	<5
Total Alkalinity	mg/l as CaCO3 (1)	82	95	78
Hardness	mg/l as CaCO3 (0.02)	84	83	
Total Suspended Solids	mg/l (0.05)	0.7	18	
Ammonia	mg/l as N (0.03)	0.019	60	
Nitrate+Nitrite	mg/l as N (0.01)	0.006	33	
Total Kjeldahl Nitrogen	mg/l as N (0.06)	0.39	<5	
Orthophosphorus	mg/l as P (0.01)	0.005	56	
Chloride	mg/l (0.05)	12	23	
Sulfate	mg/l (0.05)	1	6	
Sodium	mg/l (0.06)	7.2	35	
Potassium	mg/l (0.07)	0.3	7	
Calcium	mg/l (0.04)	31.0	93	
Magnesium	mg/l (0.006)	1.7	20	
Iron	ug/l (0.03)	18	16	

Based upon the average FTSI of 26, water quality is considered good. Round Lake can be characterized as a clear (color<=10 color units), medium hard water, oligotrophic lake, with low concentrations of total phosphorus, very low concentrations of total nitrogen. The chemical type of water (predominant ionic composition) is calcium bicarbonate. Round Lake is augmented with water from the Floridan Aquifer, resulting in relatively high total alkalinity, total hardness, and calcium, in a region typified by much lower natural levels (see, for example, neighboring lakes Zambito, Reinheimer, and Merrywater).

Plots and Trends: Plots of conductance, total alkalinity, and hardness show a wide range in fluctuation, probably due to variable augmentation of the lake water with water from the Florida Aquifer. Also shown is a diagram of the relative ionic composition of the lake water.

MONTHLY AVERAGE SURFACE ELEVATION

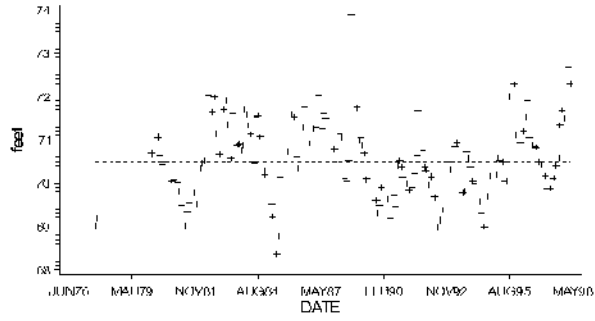

SPEC. CONDUCTANCE

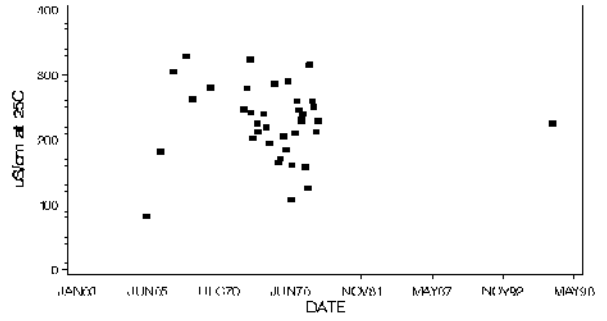

TOTAL ALKALINITY

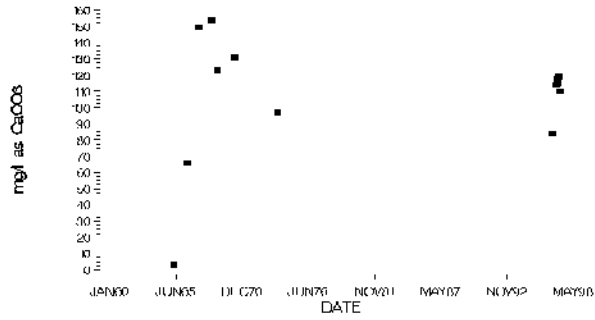

HARDNESS

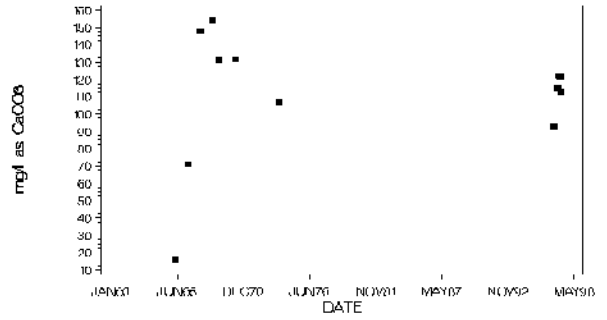

MAJOR IONS (% meq/l)

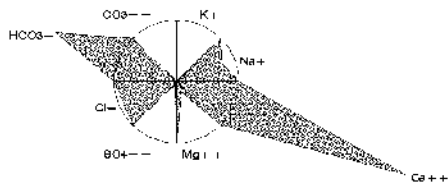

Sapphire Lake

Hillsborough County

USGS Quadrangle: Lutz Major Land Use/Land Cover (1990)
 Section/Township/Range: 14-27S-18E within 500 meters of the lakeshore:
 Approx. Lake Center, Lat/Long: 280826/822853 - medium density residential (29%)
 Surface Area: 11 acres - cypress (24%)
 Approx. Lake Elevation: 64 feet - low density residential (14%)
 Average Depth: 7.6 feet
 Observed Maximum Depth: 20.5 feet
 (reference elevation 63.5 feet)
 Lake Type: isolated (type 4)
 Major Basin: Tampa Bay Drainage
 Minor Basin: Upper Rocky Creek
 Lake Region: Land-o-Lakes

Total Number of Samples Collected: 4 Most Recent Sample Collected: February 1997

Parameter	Units (Detection Limit)	Average Value	District Percentile	Florida Percentile
Chlorophyll a	ug/l (1)	6.5	51	28
Total Phosphorus	mg/l as P (0.01)	0.016	56	8
Total Nitrogen	mg/l as N (0.06)	1.29	60	45
Transparency (Secchi depth)	meters	1.86	60	83
Florida Trophic State Index		40	54	16
Specific Conductance	S/cm at 25C (1)	237	75	58
pH	standard units (0.1)	7.6	64	57
Color	PtCo units (1)	24	60	19
Turbidity	NTU (1)	2.5	58	26
Total Alkalinity	mg/l as CaCO3 (1)	24	48	43
Hardness	mg/l as CaCO3 (0.02)	36	29	
Total Suspended Solids	mg/l (0.05)	2.1	54	
Ammonia	mg/l as N (0.03)	0.032	63	
Nitrate+Nitrite	mg/l as N (0.01)	0.050	69	
Total Kjeldahl Nitrogen	mg/l as N (0.06)	1.24	64	
Orthophosphorus	mg/l as P (0.01)	0.008	56	
Chloride	mg/l (0.05)	46	>95	
Sulfate	mg/l (0.05)	12	41	
Sodium	mg/l (0.06)	31.3	>95	
Potassium	mg/l (0.07)	2.4	39	
Calcium	mg/l (0.04)	11.1	44	
Magnesium	mg/l (0.006)	2.1	28	
Iron	ug/l (0.03)	22	25	

Based upon the average FTSI of 40, water quality is considered good. Sapphire Lake can be characterized as a moderately colored, soft water, mesotrophic lake. The chemical type of water (predominant ionic composition) is sodium chloride.

Also of note:

- Melaleuca was observed on the lake shore.

Plots and Trends: No or insufficient data available for plotting or trend detection. Shown is a diagram of the relative ionic composition of the lake water.

MAJOR IONS (% meq/l)

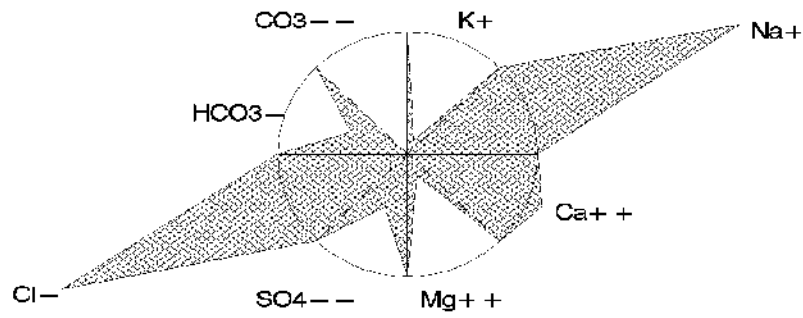

Sapphire Lake, Hillsborough County

Starvation Lake

Hillsborough County

USGS Quadrangle: Citrus Park Major Land Use/Land Cover (1990)
 Section/Township/Range: 21-27S-18E within 500 meters of the lakeshore:
 Approx. Lake Center, Lat/Long: 280725/823018 - open land (23%)
 Surface Area: 52 acres - shrub and brushland range (20%)
 Approx. Lake Elevation: 53 feet - wetland forested mixed (12%)
 Average Depth: 5.2 feet
 Observed Maximum Depth: 14.5 feet
 (reference elevation 52.5 feet)
 Lake Type: isolated (type 4)
 Major Basin: Tampa Bay Drainage
 Minor Basin: Brushy Creek
 Lake Region: Land-o-Lakes
 Public Access: yes

Total Number of Samples Collected: 2 Most Recent Sample Collected: January 1995

Parameter	Units (Detection Limit)	Average Value	District Percentile	Florida Percentile
Chlorophyll a	ug/l (1)	2.6	19	11
Total Phosphorus	mg/l as P (0.01)	0.005	31	<5
Total Nitrogen	mg/l as N (0.06)	0.62	12	16
Transparency (Secchi depth)	meters	1.80	58	82
Florida Trophic State Index		31	31	6
Specific Conductance	S/cm at 25C (1)	159	42	44
pH	standard units (0.1)	7.6	64	57
Color	PtCo units (1)	10	34	10
Turbidity	NTU (1)	1.4	39	11
Total Alkalinity	mg/l as CaCO3 (1)	34	64	52
Hardness	mg/l as CaCO3 (0.02)	65	68	
Total Suspended Solids	mg/l (0.05)	1.6	42	
Ammonia	mg/l as N (0.03)	0.015	60	
Nitrate+Nitrite	mg/l as N (0.01)	0.005	33	
Total Kjeldahl Nitrogen	mg/l as N (0.06)	0.62	17	
Orthophosphorus	mg/l as P (0.01)	0.005	56	
Chloride	mg/l (0.05)	11	19	
Sulfate	mg/l (0.05)	21	63	
Sodium	mg/l (0.06)	4.2	10	
Potassium	mg/l (0.07)	0.0	<5	
Calcium	mg/l (0.04)	22.5	82	
Magnesium	mg/l (0.006)	2.1	28	
Iron	ug/l (0.03)	44	57	

Based upon the average FTSI of 31, water quality is considered good. Starvation Lake can be characterized as a clear (color<=10 color units), medium hard water, oligo-mesotrophic lake, with low concentrations of total phosphorus and low concentrations of total nitrogen. The chemical type of water (predominant ionic composition) is calcium sulfate.

Plots and Trends: Historically, Starvation Lake was augmented with water from the Florida Aquifer. The wide range in variation for some of the variables plotted, including conductance, hardness and alkalinity, may be a reflection of this. Lake surface elevation has fluctuated over a 14-foot range. Also shown is a diagram of the relative ionic composition of the lake water.

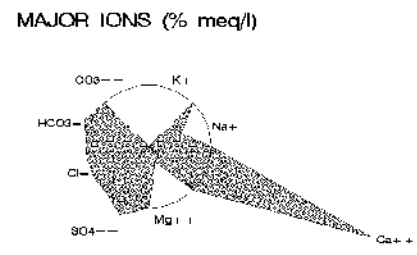
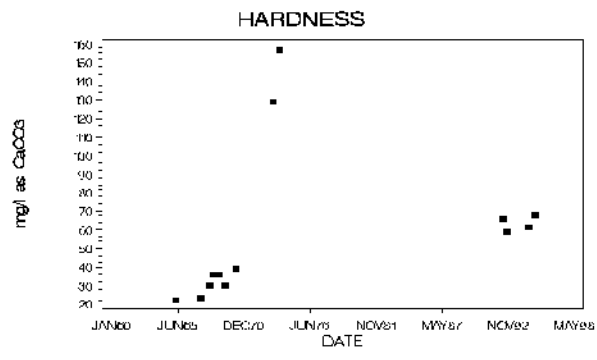
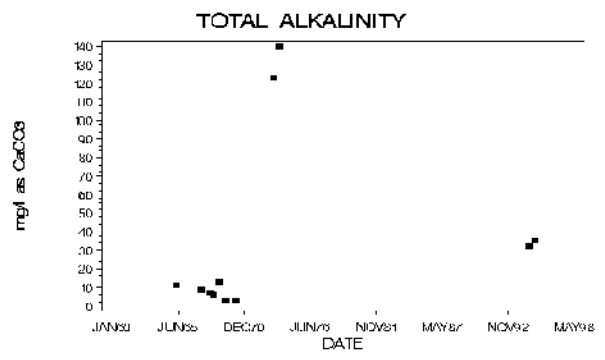
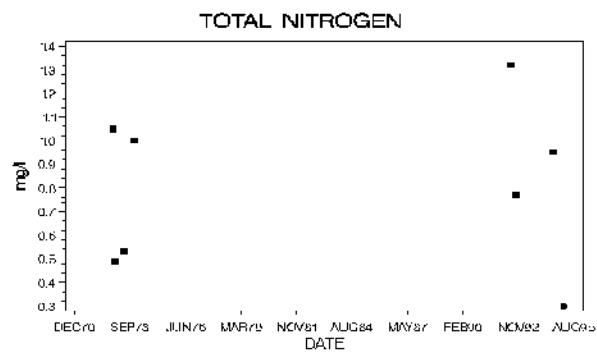
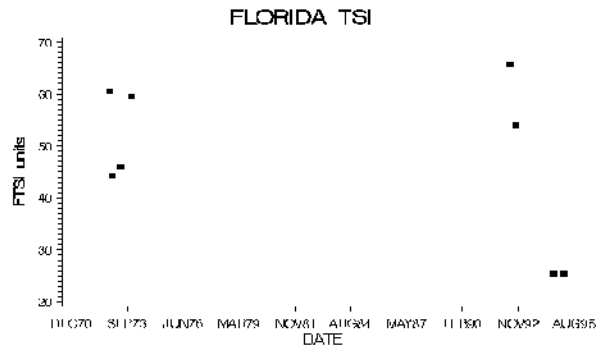
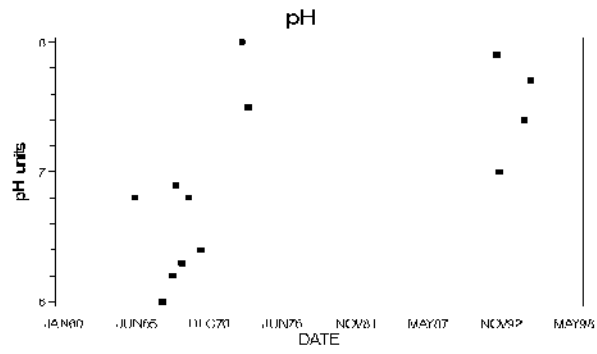
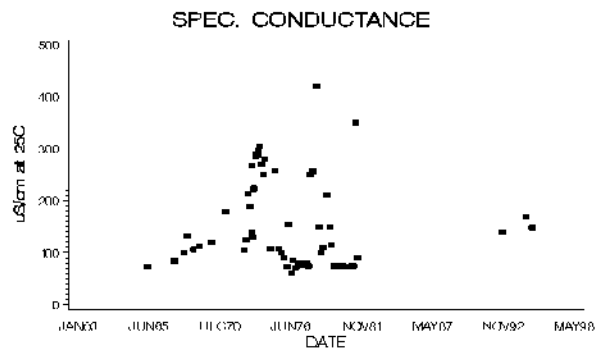
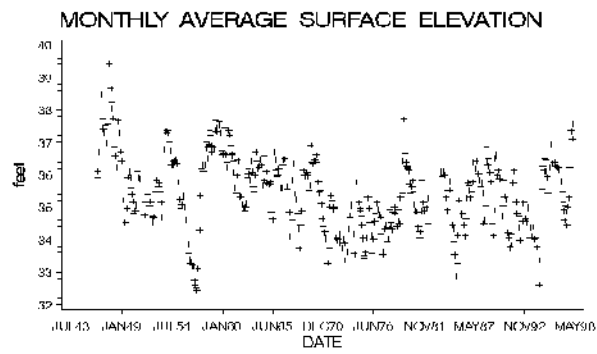

Starvation Lake, Hillsborough County

Lake Stemper Hillsborough County

USGS Quadrangle:	Lutz	Major Land Use/Land Cover (1990)
Section/Township/Range:	13-27S-18E	within 500 meters of the lakeshore:
Approx. Lake Center, Lat/Long:	280802/822726	- tree crops, typically citrus (25%)
Surface Area:	126 acres	- cropland and pastureland (13%)
Approx. Lake Elevation:	62 feet	- cypress (13%)
Average Depth:	3.5 feet	
Observed Maximum Depth:	12.2 feet	
(reference elevation 61.2 feet)		
Lake Type:	inflow and outflow (type 3)	
Major Basin:	Hillsborough River	
Minor Basin:	Lake Hanna Outlet	
Lake Region:	Land-o-Lakes	

Total Number of Samples Collected: 12 Most Recent Sample Collected: February 1997

Parameter	Units (Detection Limit)	Average Value	District Percentile	Florida Percentile
Chlorophyll a	ug/l (1)	15.8	75	46
Total Phosphorus	mg/l as P (0.01)	0.024	71	14
Total Nitrogen	mg/l as N (0.06)	2.22	88	84
Transparency (Secchi depth)	meters	0.89	28	59
Florida Trophic State Index		51	75	37
Specific Conductance	S/cm at 25C (1)	179	49	48
pH	standard units (0.1)	7.2	43	40
Color	PtCo units (1)	68	83	58
Turbidity	NTU (1)	6.5	79	58
Total Alkalinity	mg/l as CaCO3 (1)	20	42	39
Hardness	mg/l as CaCO3 (0.02)	37	30	
Total Suspended Solids	mg/l (0.05)	6.2	82	
Ammonia	mg/l as N (0.03)	0.089	85	
Nitrate+Nitrite	mg/l as N (0.01)	0.074	78	
Total Kjeldahl Nitrogen	mg/l as N (0.06)	2.14	93	
Orthophosphorus	mg/l as P (0.01)	0.010	59	
Chloride	mg/l (0.05)	24	74	
Sulfate	mg/l (0.05)	19	58	
Sodium	mg/l (0.06)	13.2	78	
Potassium	mg/l (0.07)	4.0	56	
Calcium	mg/l (0.04)	14.9	59	
Magnesium	mg/l (0.006)	3.2	48	
Iron	ug/l (0.03)	53	63	

Based upon the average FTSI of 51, water quality is considered good. Lake Stemper can be characterized as a colored, soft water, meso-eutrophic lake, with high concentrations of total nitrogen. The chemical type of water (predominant ionic composition) is sodium chloride (6 samples) or calcium chloride (4 samples).

Also of note:

- Melaleuca was observed on the lake shore.

Plots and Trends: Shown are plots of conductance, alkalinity and hardness. Though variable, the large gap in the data makes it impossible to conclude any changes in water chemistry over time. Lake surface elevations appear to be fluctuating with greater amplitude in recent decades, compared to historical data of the 1940s through the 1960s. Also shown is a diagram of the relative ionic composition of the lake water.

MONTHLY AVERAGE SURFACE ELEVATION

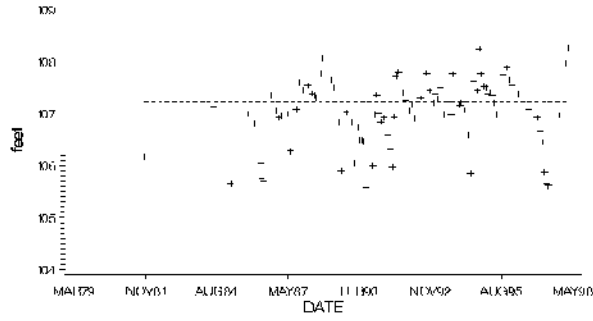

SPEC. CONDUCTANCE

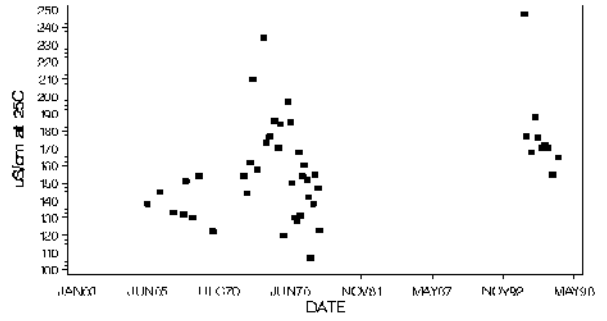

TOTAL ALKALINITY

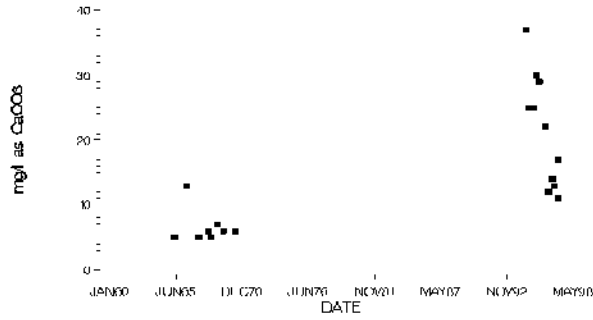

HARDNESS

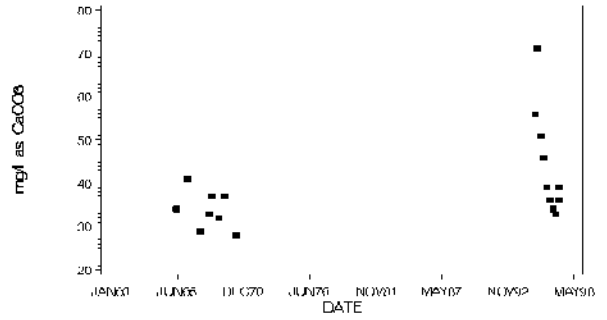

MAJOR IONS (% meq/l)

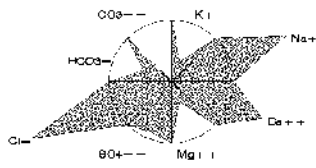

Sunshine Lake

Hillsborough County

USGS Quadrangle: Citrus Park Major Land Use/Land Cover (1990)
 Section/Township/Range: 20-27S-18E within 500 meters of the lakeshore:
 Approx. Lake Center, Lat/Long: 280710/823132 - low density residential (38%)
 Surface Area: 17 acres - cropland and pastureland (31%)
 Approx. Lake Elevation: 54 feet - cypress (14%)
 Average Depth: 7.3 feet
 Observed Maximum Depth: 11.4 feet
 (reference elevation 53.4 feet)
 Lake Type: inflow and outflow (type 3)
 Major Basin: Tampa Bay Drainage
 Minor Basin: Brushy Creek
 Lake Region: Tampa Plain

Total Number of Samples Collected: 2 Most Recent Sample Collected: January 1997

Parameter	Units (Detection Limit)	Average Value	District Percentile	Florida Percentile
Chlorophyll a	ug/l (1)	7.7	56	32
Total Phosphorus	mg/l as P (0.01)	0.012	41	6
Total Nitrogen	mg/l as N (0.06)	1.18	54	39
Transparency (Secchi depth)	meters	1.75	57	81
Florida Trophic State Index		40	52	15
Specific Conductance	S/cm at 25C (1)	130	25	35
pH	standard units (0.1)	7.4	57	50
Color	PtCo units (1)	50	79	40
Turbidity	NTU (1)	2.8	61	30
Total Alkalinity	mg/l as CaCO3 (1)	21	43	40
Hardness	mg/l as CaCO3 (0.02)	31	23	
Total Suspended Solids	mg/l (0.05)	2.4	57	
Ammonia	mg/l as N (0.03)	0.015	60	
Nitrate+Nitrite	mg/l as N (0.01)	0.018	48	
Total Kjeldahl Nitrogen	mg/l as N (0.06)	1.16	59	
Orthophosphorus	mg/l as P (0.01)	0.008	56	
Chloride	mg/l (0.05)	20	56	
Sulfate	mg/l (0.05)	9	34	
Sodium	mg/l (0.06)	13.5	78	
Potassium	mg/l (0.07)	1.1	20	
Calcium	mg/l (0.04)	9.3	36	
Magnesium	mg/l (0.006)	2.0	25	
Iron	ug/l (0.03)	23	27	

Based upon the average FTSI of 40, water quality is considered good. Sunshine Lake can be characterized as a colored, soft water, eutrophic lake. The chemical type of water (predominant ionic composition) is calcium chloride (1 sample) or sodium chloride (1 sample).

Plots and Trends: No or insufficient data available for plotting or trend detection. Shown is a diagram of the relative ionic composition of the lake water.

MAJOR IONS (% meq/l)

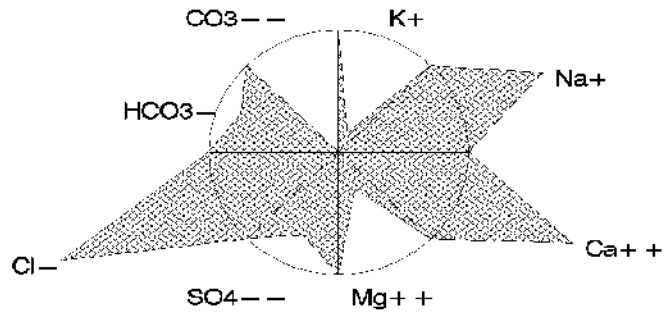

Sunshine Lake, Hillsborough County

Sunset Lake

Hillsborough County

USGS Quadrangle: Elfers Major Land Use/Land Cover (1990)
 Section/Township/Range: 17-27S-17E within 500 meters of the lakeshore:
 Approx. Lake Center, Lat/Long: 280806/823733 - low density residential (38%)
 Surface Area: 37 acres - stream and lake swamps (11%)
 Approx. Lake Elevation: 35 feet - cropland and pastureland (9%)
 Average Depth: 5.9 feet
 Observed Maximum Depth: 12.2 feet
 (reference elevation 33.2 feet)
 Lake Type: isolated (type 4)
 Major Basin: Tampa Bay Drainage
 Minor Basin: Sunset Lake Outlet
 Lake Region: Keystone Lakes

Total Number of Samples Collected: 2 Most Recent Sample Collected: January 1996

Parameter	Units (Detection Limit)	Average Value	District Percentile	Florida Percentile
Chlorophyll a	ug/l (1)	8.3	58	34
Total Phosphorus	mg/l as P (0.01)	0.011	38	6
Total Nitrogen	mg/l as N (0.06)	1.40	66	50
Transparency (Secchi depth)	meters	1.00	35	63
Florida Trophic State Index		47	68	29
Specific Conductance	S/cm at 25C (1)	201	59	52
pH	standard units (0.1)	7.8	74	63
Color	PtCo units (1)	40	72	30
Turbidity	NTU (1)	2.5	58	26
Total Alkalinity	mg/l as CaCO3 (1)	36	67	53
Hardness	mg/l as CaCO3 (0.02)	52	54	
Total Suspended Solids	mg/l (0.05)	3.3	66	
Ammonia	mg/l as N (0.03)	0.096	87	
Nitrate+Nitrite	mg/l as N (0.01)	0.019	50	
Total Kjeldahl Nitrogen	mg/l as N (0.06)	1.38	73	
Orthophosphorus	mg/l as P (0.01)	0.009	56	
Chloride	mg/l (0.05)	29	83	
Sulfate	mg/l (0.05)	12	41	
Sodium	mg/l (0.06)	17.0	88	
Potassium	mg/l (0.07)	1.7	28	
Calcium	mg/l (0.04)	16.5	64	
Magnesium	mg/l (0.006)	2.6	38	
Iron	ug/l (0.03)	35	47	

Based upon the average FTSI of 47, water quality is considered good. Sunset Lake can be characterized as a colored, soft water, meso-eutrophic lake. The chemical type of water (predominant ionic composition) is calcium chloride.

Plots and Trends: Lake surface elevation has been stable over the period of record. Though it is greater than measured in the 1970s, specific conductance data are insufficient to determine if there has been a significant change over time. Also shown is a diagram of the relative ionic composition of the lake water.

MONTHLY AVERAGE SURFACE ELEVATION

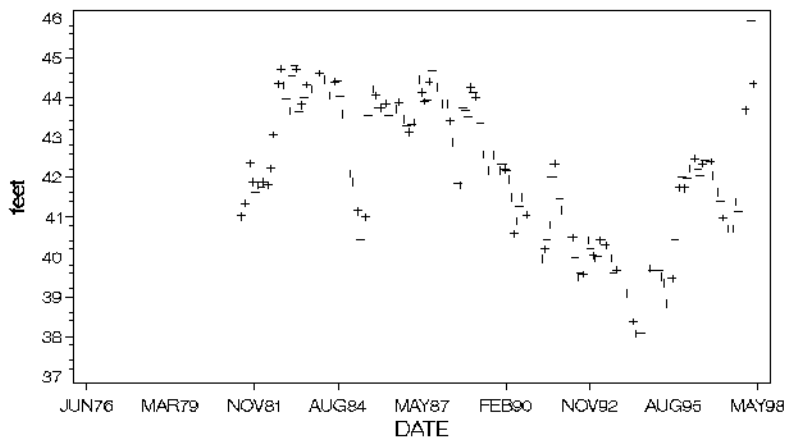

SPEC. CONDUCTANCE

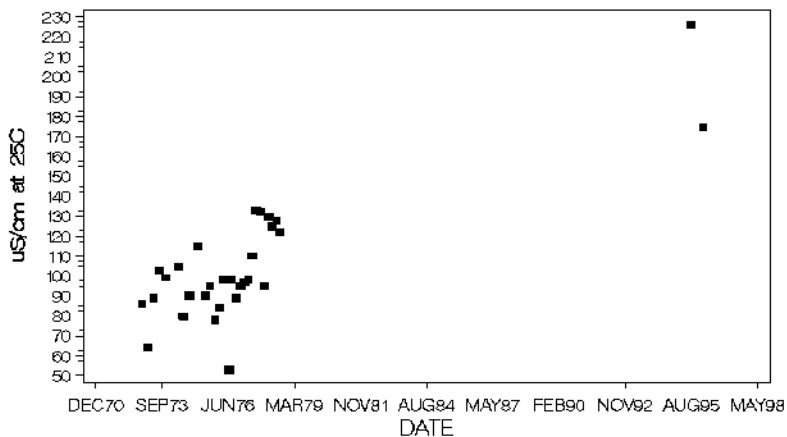

MAJOR IONS (% meq/l)

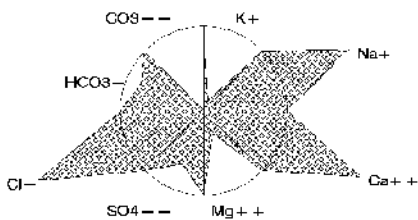

Lake Taylor Hillsborough County

USGS Quadrangle: Odessa Major Land Use/Land Cover (1990)
 Section/Township/Range: 16-27S-17E within 500 meters of the lakeshore:
 Approx. Lake Center, Lat/Long: 280810/823646 - low density residential (17%)
 Surface Area: 44 acres - medium density residential (16%)
 Approx. Lake Elevation: 39 feet - cropland and pastureland (13%)
 Average Depth: 5.7 feet
 Observed Maximum Depth: 15.3 feet
 (reference elevation 39.3 feet)
 Lake Type: inflow and outflow (type 3)
 Major Basin: Tampa Bay Drainage
 Minor Basin: Unnamed Ditch
 Lake Region: Keystone Lakes

Total Number of Samples Collected: 2 Most Recent Sample Collected: February 1997

Parameter	Units (Detection Limit)	Average Value	District Percentile	Florida Percentile
Chlorophyll a	ug/l (1)	4.6	41	19
Total Phosphorus	mg/l as P (0.01)	0.012	41	6
Total Nitrogen	mg/l as N (0.06)	0.73	20	22
Transparency (Secchi depth)	meters	2.71	79	93
Florida Trophic State Index		34	38	9
Specific Conductance	S/cm at 25C (1)	126	23	34
pH	standard units (0.1)	6.6	18	20
Color	PtCo units (1)	13	41	12
Turbidity	NTU (1)	1.4	39	11
Total Alkalinity	mg/l as CaCO3 (1)	6	15	17
Hardness	mg/l as CaCO3 (0.02)	22	11	
Total Suspended Solids	mg/l (0.05)	1.2	33	
Ammonia	mg/l as N (0.03)	0.015	60	
Nitrate+Nitrite	mg/l as N (0.01)	0.060	72	
Total Kjeldahl Nitrogen	mg/l as N (0.06)	0.67	22	
Orthophosphorus	mg/l as P (0.01)	0.008	56	
Chloride	mg/l (0.05)	20	56	
Sulfate	mg/l (0.05)	12	41	
Sodium	mg/l (0.06)	12.5	73	
Potassium	mg/l (0.07)	2.1	35	
Calcium	mg/l (0.04)	5.5	16	
Magnesium	mg/l (0.006)	2.2	31	
Iron	ug/l (0.03)	20	19	

Based upon the average FTSI of 34, water quality is considered good. Lake Taylor can be characterized as a clear to moderately colored (10<color<20 color units), soft water, mesotrophic lake, with low concentrations of total nitrogen. The chemical type of water (predominant ionic composition) is sodium chloride.

Also of note:

- Melaleuca was observed on the lake shore.

Plots and Trends: Lake surface elevations have been relatively stable over the period of record. Recent measures of specific conductance were similar to the historic values. Also shown is a diagram of the relative ionic composition of the lake water.

Tenmile Lake

Hillsborough County

USGS Quadrangle: Brandon Major Land Use/Land Cover (1990)
 Section/Township/Range: 20-29S-20E within 500 meters of the lakeshore:
 Approx. Lake Center, Lat/Long: 275624/821854 - commercial and services (27%)
 Surface Area: 6 acres - low density residential (22%)
 Approx. Lake Elevation: 35 feet - cropland and pastureland (17%)
 Lake Type: outflow (type 2)
 Major Basin: Tampa Bay Drainage
 Minor Basin: Delaney Creek
 Lake Region: Southwestern Flatlands

Total Number of Samples Collected: 2 Most Recent Sample Collected: January 1996

Parameter	Units (Detection Limit)	Average Value	District Percentile	Florida Percentile
Chlorophyll a	ug/l (1)	31.1	85	66
Total Phosphorus	mg/l as P (0.01)	0.025	72	15
Total Nitrogen	mg/l as N (0.06)	0.87	30	29
Transparency (Secchi depth)	meters	0.86	27	56
Florida Trophic State Index		58	82	51
Specific Conductance	S/cm at 25C (1)	146	35	41
pH	standard units (0.1)	8.2	85	75
Color	PtCo units (1)	13	41	12
Turbidity	NTU (1)	11.4	91	72
Total Alkalinity	mg/l as CaCO3 (1)	44	76	59
Hardness	mg/l as CaCO3 (0.02)	56	58	
Total Suspended Solids	mg/l (0.05)	6.6	85	
Ammonia	mg/l as N (0.03)	0.023	60	
Nitrate+Nitrite	mg/l as N (0.01)	0.005	33	
Total Kjeldahl Nitrogen	mg/l as N (0.06)	0.86	36	
Orthophosphorus	mg/l as P (0.01)	0.005	56	
Chloride	mg/l (0.05)	12	23	
Sulfate	mg/l (0.05)	9	34	
Sodium	mg/l (0.06)	6.5	27	
Potassium	mg/l (0.07)	1.1	20	
Calcium	mg/l (0.04)	17.5	67	
Magnesium	mg/l (0.006)	2.9	43	
Iron	ug/l (0.03)	57	66	

Based upon the average FTSI of 58, water quality is considered good. Tenmile Lake can be characterized as a clear to moderately colored (10<color<20 color units), soft water, eutrophic to hypereutrophic lake. The chemical type of water (predominant ionic composition) is calcium bicarbonate.

Also of note:

- The measured pH was high

Plots and Trends: No or insufficient data available for plotting or trend detection. Shown is a diagram of the relative ionic composition of the lake water.

MAJOR IONS (% meq/l)

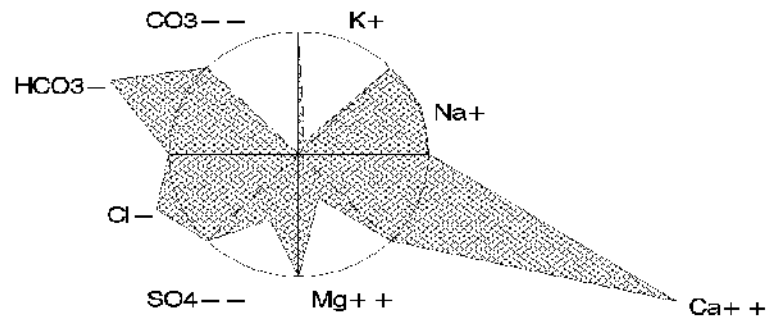

Tenmile Lake, Hillsborough County

Thorpe Lake Hillsborough County

USGS Quadrangle: Citrus Park Major Land Use/Land Cover (1990)
 Section/Township/Range: 28-27S-17E within 500 meters of the lakeshore:
 Approx. Lake Center, Lat/Long: 280603/823618 - medium density residential (42%)
 Surface Area: 13 acres - tree crops, typically citrus (22%)
 Approx. Lake Elevation: 32 feet - wetland forested mixed (8%)
 Lake Type: isolated (type 4)
 Major Basin: Tampa Bay Drainage
 Minor Basin: Unnamed Ditch
 Lake Region: Keystone Lakes

Total Number of Samples Collected: 2 Most Recent Sample Collected: February 1997

Parameter	Units (Detection Limit)	Average Value	District Percentile	Florida Percentile
Chlorophyll a	ug/l (1)	4.1	37	17
Total Phosphorus	mg/l as P (0.01)	0.005	31	<5
Total Nitrogen	mg/l as N (0.06)	0.70	17	20
Transparency (Secchi depth)	meters	2.32	72	90
Florida Trophic State Index		29	24	<5
Specific Conductance	S/cm at 25C (1)	141	31	40
pH	standard units (0.1)	5.2	<5	<5
Color	PtCo units (1)	18	51	15
Turbidity	NTU (1)	0.9	28	<5
Total Alkalinity	mg/l as CaCO3 (1)	2	<5	5
Hardness	mg/l as CaCO3 (0.02)	29	19	
Total Suspended Solids	mg/l (0.05)	1.0	28	
Ammonia	mg/l as N (0.03)	0.015	60	
Nitrate+Nitrite	mg/l as N (0.01)	0.062	74	
Total Kjeldahl Nitrogen	mg/l as N (0.06)	0.64	19	
Orthophosphorus	mg/l as P (0.01)	0.005	56	
Chloride	mg/l (0.05)	21	61	
Sulfate	mg/l (0.05)	23	67	
Sodium	mg/l (0.06)	12.0	69	
Potassium	mg/l (0.07)	2.1	35	
Calcium	mg/l (0.04)	6.6	22	
Magnesium	mg/l (0.006)	3.1	47	
Iron	ug/l (0.03)	83	76	

Based upon the average FTSI of 29, water quality is considered good. Thorpe Lake can be characterized as a clear to moderately colored (10 < color < 20 color units), soft water, mesotrophic lake, with low concentrations of total phosphorus, low concentrations of total nitrogen. The chemical type of water (predominant ionic composition) is sodium chloride.

Also of note:

- The measured pH was low.

Plots and Trends: No or insufficient data available for plotting or trend detection. Shown is a diagram of the relative ionic composition of the lake water.

MAJOR IONS (% meq/l)

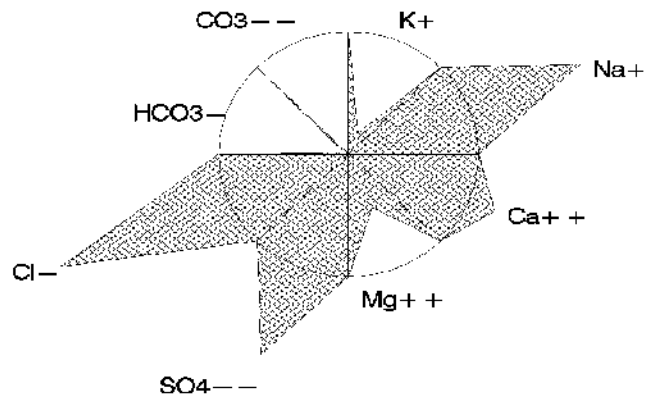

Thorpe Lake, Hillsborough County

Turkey Ford Lake Hillsborough County

USGS Quadrangle:	Odessa	Major Land Use/Land Cover (1990)
Section/Township/Range:	18-27S-18E	within 500 meters of the lakeshore:
Approx. Lake Center, Lat/Long:	280757/823226	- high density residential (32%)
Surface Area:	93 acres	- cypress (30%)
Approx. Lake Elevation:	54 feet	- cropland and pastureland (17%)
Lake Type:	outflow (type 2)	
Major Basin:	Tampa Bay Drainage	
Minor Basin:	Upper Rocky Creek	
Lake Region:	Tampa Plain	

Total Number of Samples Collected: 2 Most Recent Sample Collected: January 1995

Parameter	Units (Detection Limit)	Average Value	District Percentile	Florida Percentile
Chlorophyll a	ug/l (1)	0.8	<5	<5
Total Phosphorus	mg/l as P (0.01)	0.039	83	29
Total Nitrogen	mg/l as N (0.06)	1.04	43	35
Transparency (Secchi depth)	meters	0.88	27	58
Florida Trophic State Index		43	59	20
Specific Conductance	S/cm at 25C (1)	127	23	34
pH	standard units (0.1)	6.2	8	10
Color	PtCo units (1)	23	58	19
Turbidity	NTU (1)	4.0	70	42
Total Alkalinity	mg/l as CaCO3 (1)	6	15	17
Hardness	mg/l as CaCO3 (0.02)	26	16	
Total Suspended Solids	mg/l (0.05)	2.8	62	
Ammonia	mg/l as N (0.03)	0.015	60	
Nitrate+Nitrite	mg/l as N (0.01)	0.069	77	
Total Kjeldahl Nitrogen	mg/l as N (0.06)	0.97	45	
Orthophosphorus	mg/l as P (0.01)	0.016	82	
Chloride	mg/l (0.05)	24	74	
Sulfate	mg/l (0.05)	10	37	
Sodium	mg/l (0.06)	10.5	62	
Potassium	mg/l (0.07)	3.9	54	
Calcium	mg/l (0.04)	6.8	23	
Magnesium	mg/l (0.006)	2.1	28	
Iron	ug/l (0.03)	266	94	

Based upon the average FTSI of 43, water quality is considered good. Turkey Ford Lake can be characterized as a moderately colored, soft water, mesotrophic lake, with high concentrations of total phosphorus. The chemical type of water (predominant ionic composition) is sodium chloride.

Plots and Trends: Lake surface elevations have been relatively stable over the period of record. Recent measurements of specific conductance were within the range of the historical values. Also shown is a diagram of the relative ionic composition of the lake water.

MONTHLY AVERAGE SURFACE ELEVATION

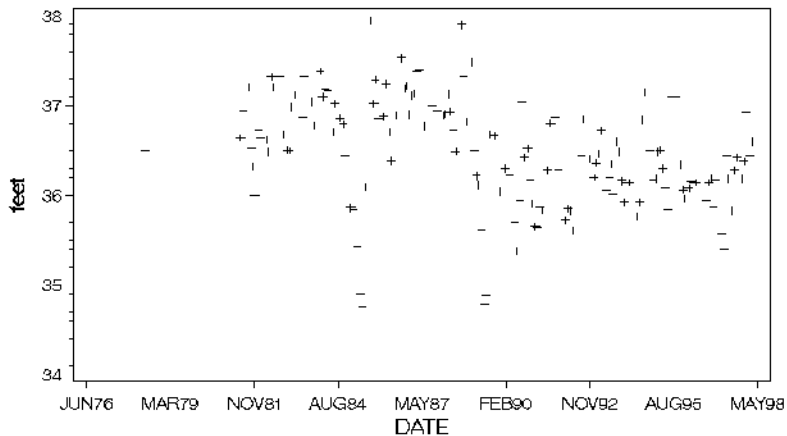

SPEC. CONDUCTANCE

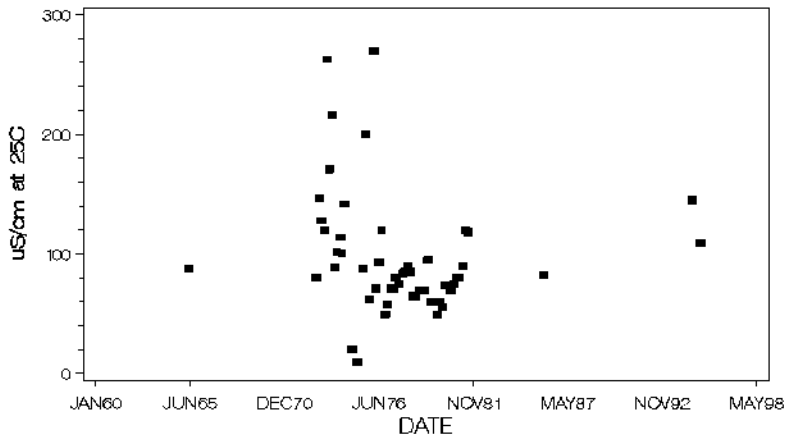

MAJOR IONS (% meq/l)

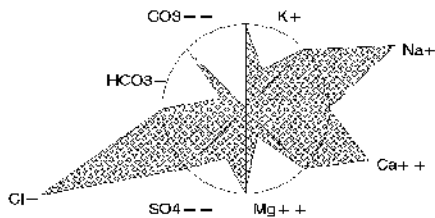

Turkey Ford Lake, Hillsborough County

Twin Lake

Hillsborough County

USGS Quadrangle: Sulphur Springs Major Land Use/Land Cover (1990)
 Section/Township/Range: 22-28S-18E within 500 meters of the lakeshore:
 Approx. Lake Center, Lat/Long: 280157/822923 - high density residential (58%)
 Surface Area: 27 acres - commercial and services (12%)
 Approx. Lake Elevation: 32 feet - medium density residential (7%)
 Lake Type: outflow (type 2)
 Major Basin: Hillsborough River
 Minor Basin: Twin Lake Outlet
 Lake Region: Land-o-Lakes

Total Number of Samples Collected: 2 Most Recent Sample Collected: January 1995

Parameter	Units (Detection Limit)	Average Value	District Percentile	Florida Percentile
Chlorophyll a	ug/l (1)	18.2	77	50
Total Phosphorus	mg/l as P (0.01)	0.021	66	11
Total Nitrogen	mg/l as N (0.06)	0.74	21	22
Transparency (Secchi depth)	meters	0.80	24	50
Florida Trophic State Index		55	78	44
Specific Conductance	S/cm at 25C (1)	236	75	58
pH	standard units (0.1)	7.7	69	60
Color	PtCo units (1)	10	34	10
Turbidity	NTU (1)	3.4	66	36
Total Alkalinity	mg/l as CaCO3 (1)	56	84	66
Hardness	mg/l as CaCO3 (0.02)	76	76	
Total Suspended Solids	mg/l (0.05)	4.8	77	
Ammonia	mg/l as N (0.03)	0.078	84	
Nitrate+Nitrite	mg/l as N (0.01)	0.005	33	
Total Kjeldahl Nitrogen	mg/l as N (0.06)	0.74	28	
Orthophosphorus	mg/l as P (0.01)	0.013	72	
Chloride	mg/l (0.05)	23	69	
Sulfate	mg/l (0.05)	27	73	
Sodium	mg/l (0.06)	12.5	73	
Potassium	mg/l (0.07)	3.0	46	
Calcium	mg/l (0.04)	26.5	88	
Magnesium	mg/l (0.006)	2.4	35	
Iron	ug/l (0.03)	28	34	

Based upon the average FTSI of 55, water quality is considered good. Twin Lake can be characterized as a clear (color<=10 color units), medium hard water, eutrophic lake, with low concentrations of total nitrogen. The chemical type of water (predominant ionic composition) is calcium bicarbonate (1 sample) or calcium chloride (1 sample).

Plots and Trends: No or insufficient data available for plotting or trend detection. Shown is a diagram of the relative ionic composition of the lake water.

MAJOR IONS (% meq/l)

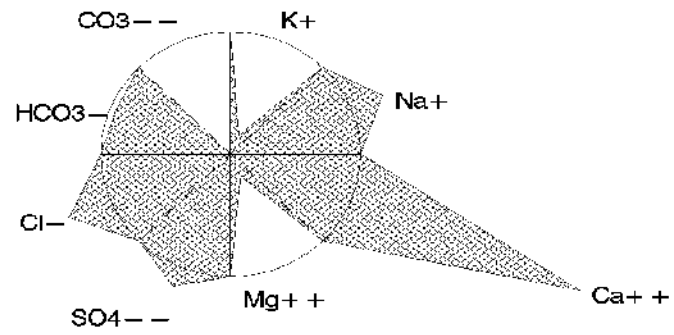

Valrico Lake

Hillsborough County

USGS Quadrangle: Brandon Major Land Use/Land Cover (1990)
 Section/Township/Range: 13-29S-20E within 500 meters of the lakeshore:
 Approx. Lake Center, Lat/Long: 275711/821529 - medium density residential (38%)
 Surface Area: 127 acres - open land (16%)
 Approx. Lake Elevation: 45 feet - high density residential (14%)
 Lake Type: outflow (type 2)
 Major Basin: Hillsborough River
 Minor Basin: Selfer Canal
 Lake Region: Hillsborough Valley

Total Number of Samples Collected: 2 Most Recent Sample Collected: January 1996

Parameter	Units (Detection Limit)	Average Value	District Percentile	Florida Percentile
Chlorophyll a	ug/l (1)	3.7	33	15
Total Phosphorus	mg/l as P (0.01)	0.043	85	37
Total Nitrogen	mg/l as N (0.06)	1.27	59	44
Transparency (Secchi depth)	meters	0.90	28	60
Florida Trophic State Index		43	58	20
Specific Conductance	S/cm at 25C (1)	134	27	37
pH	standard units (0.1)	8.2	85	75
Color	PtCo units (1)	15	46	13
Turbidity	NTU (1)	1.7	45	16
Total Alkalinity	mg/l as CaCO3 (1)	36	67	53
Hardness	mg/l as CaCO3 (0.02)	43	41	
Total Suspended Solids	mg/l (0.05)	2.5	59	
Ammonia	mg/l as N (0.03)	0.096	87	
Nitrate+Nitrite	mg/l as N (0.01)	0.009	33	
Total Kjeldahl Nitrogen	mg/l as N (0.06)	1.27	66	
Orthophosphorus	mg/l as P (0.01)	0.024	87	
Chloride	mg/l (0.05)	16	37	
Sulfate	mg/l (0.05)	3	14	
Sodium	mg/l (0.06)	7.7	41	
Potassium	mg/l (0.07)	3.9	54	
Calcium	mg/l (0.04)	12.5	51	
Magnesium	mg/l (0.006)	2.8	41	
Iron	ug/l (0.03)	55	64	

Based upon the average FTSI of 43, water quality is considered good. Valrico Lake can be characterized as a clear to moderately colored (10<color<20 color units), soft water, oligo-mesotrophic lake, with high concentrations of total phosphorus. The chemical type of water (predominant ionic composition) is calcium chloride.

Also of note:

- The measured pH was high
- Hydrilla was observed in the lake.

Plots and Trends: Shown are a plot of lake surface elevation and is a diagram of the relative ionic composition of the lake water.

MONTHLY AVERAGE SURFACE ELEVATION

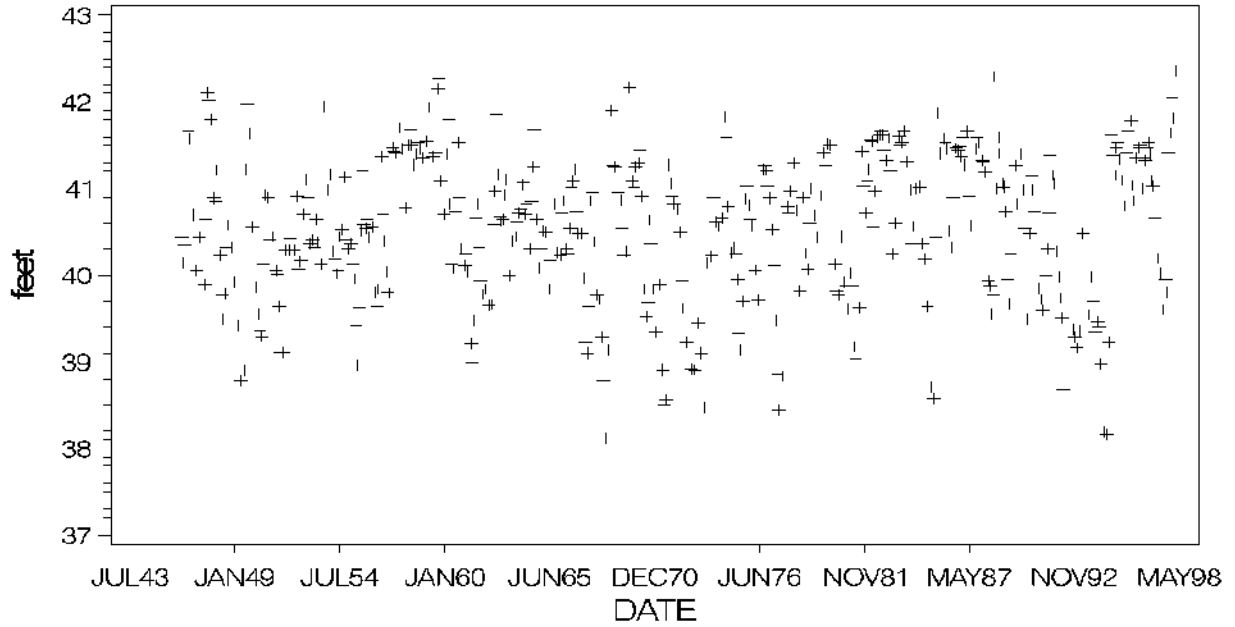

MAJOR IONS (% meq/l)

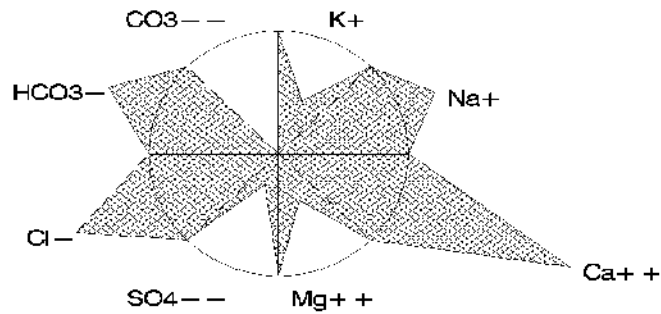

Valrico Lake, Hillsborough County

Wastena Lake

Hillsborough County

USGS Quadrangle: Odessa Major Land Use/Land Cover (1990)
 Section/Township/Range: 3-27S-17E within 500 meters of the lakeshore:
 Approx. Lake Center, Lat/Long: 280946/823529 - medium density residential (34%)
 Surface Area: 16 acres - tree crops, typically citrus (15%)
 Approx. Lake Elevation: 39 feet - low density residential (11%)
 Lake Type: outflow (type 2)
 Major Basin: Tampa Bay Drainage
 Minor Basin: Brooker Creek
 Lake Region: Keystone Lakes

Total Number of Samples Collected: 2 Most Recent Sample Collected: January 1996

Parameter	Units (Detection Limit)	Average Value	District Percentile	Florida Percentile
Chlorophyll a	ug/l (1)	2.4	17	10
Total Phosphorus	mg/l as P (0.01)	0.009	31	<5
Total Nitrogen	mg/l as N (0.06)	1.23	56	42
Transparency (Secchi depth)	meters	3.00	84	>95
Florida Trophic State Index		25	15	<5
Specific Conductance	S/cm at 25C (1)	180	50	48
pH	standard units (0.1)	7.2	43	40
Color	PtCo units (1)	10	34	10
Turbidity	NTU (1)	0.9	28	<5
Total Alkalinity	mg/l as CaCO3 (1)	9	24	24
Hardness	mg/l as CaCO3 (0.02)	45	46	
Total Suspended Solids	mg/l (0.05)	0.9	24	
Ammonia	mg/l as N (0.03)	0.052	76	
Nitrate+Nitrite	mg/l as N (0.01)	0.066	76	
Total Kjeldahl Nitrogen	mg/l as N (0.06)	1.16	59	
Orthophosphorus	mg/l as P (0.01)	0.008	56	
Chloride	mg/l (0.05)	23	69	
Sulfate	mg/l (0.05)	24	69	
Sodium	mg/l (0.06)	12.5	73	
Potassium	mg/l (0.07)	5.4	69	
Calcium	mg/l (0.04)	12.0	48	
Magnesium	mg/l (0.006)	3.6	54	
Iron	ug/l (0.03)	38	50	

Based upon the average FTSI of 25, water quality is considered good. Wastena Lake can be characterized as a clear (color<=10 color units), soft water, oligo-mesotrophic lake, with low concentrations of total phosphorus. The chemical type of water (predominant ionic composition) is calcium chloride.

Also of note:

- Hydrilla was observed in the lake.

Plots and Trends: No or insufficient data available for plotting or trend detection. Shown is a diagram of the relative ionic composition of the lake water.

MAJOR IONS (% meq/l)

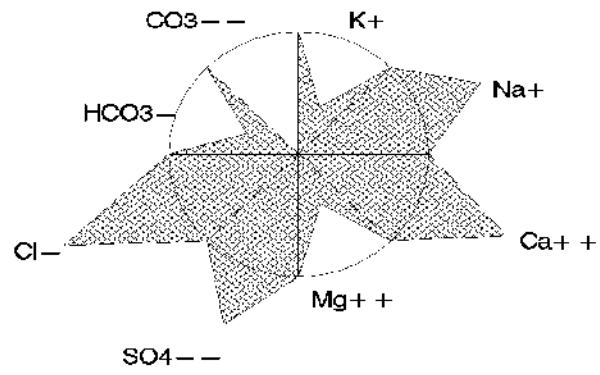

Wastena Lake, Hillsborough County

Lake Weeks

Hillsborough County

USGS Quadrangle: Brandon Major Land Use/Land Cover (1990)
 Section/Township/Range: 1-29S-20E within 500 meters of the lakeshore:
 Approx. Lake Center, Lat/Long: 275921/821608 - low density residential (21%)
 Surface Area: 55 acres - hardwood - conifer mixed (17%)
 Approx. Lake Elevation: 43 feet - medium density residential (16%)
 Lake Type: inflow and outflow (type 3)
 Major Basin: Hillsborough River
 Minor Basin: Selfer Canal
 Lake Region: Hillsborough Valley
 Public Access: yes

Total Number of Samples Collected: 2 Most Recent Sample Collected: January 1996

Parameter	Units (Detection Limit)	Average Value	District Percentile	Florida Percentile
Chlorophyll a	ug/l (1)	17.0	76	48
Total Phosphorus	mg/l as P (0.01)	0.118	95	72
Total Nitrogen	mg/l as N (0.06)	0.98	39	33
Transparency (Secchi depth)	meters	0.48	7	17
Florida Trophic State Index		66	92	69
Specific Conductance	S/cm at 25C (1)	163	43	45
pH	standard units (0.1)	7.2	43	40
Color	PtCo units (1)	45	76	35
Turbidity	NTU (1)	10.7	89	71
Total Alkalinity	mg/l as CaCO3 (1)	17	39	35
Hardness	mg/l as CaCO3 (0.02)	33	26	
Total Suspended Solids	mg/l (0.05)	12.5	94	
Ammonia	mg/l as N (0.03)	0.071	83	
Nitrate+Nitrite	mg/l as N (0.01)	0.009	33	
Total Kjeldahl Nitrogen	mg/l as N (0.06)	0.97	45	
Orthophosphorus	mg/l as P (0.01)	0.052	94	
Chloride	mg/l (0.05)	29	83	
Sulfate	mg/l (0.05)	11	39	
Sodium	mg/l (0.06)	15.5	85	
Potassium	mg/l (0.07)	4.6	62	
Calcium	mg/l (0.04)	8.8	33	
Magnesium	mg/l (0.006)	2.8	41	
Iron	ug/l (0.03)	161	89	

Based upon the average FTSI of 66, water quality is considered fair. Lake Weeks can be characterized as a colored, soft water, eutrophic lake, with high concentrations of total phosphorus. The chemical type of water (predominant ionic composition) is sodium chloride.

Plots and Trends: Lake levels have been stable over the period of record. Also shown is a diagram of the relative ionic composition of the lake water.

MONTHLY AVERAGE SURFACE ELEVATION

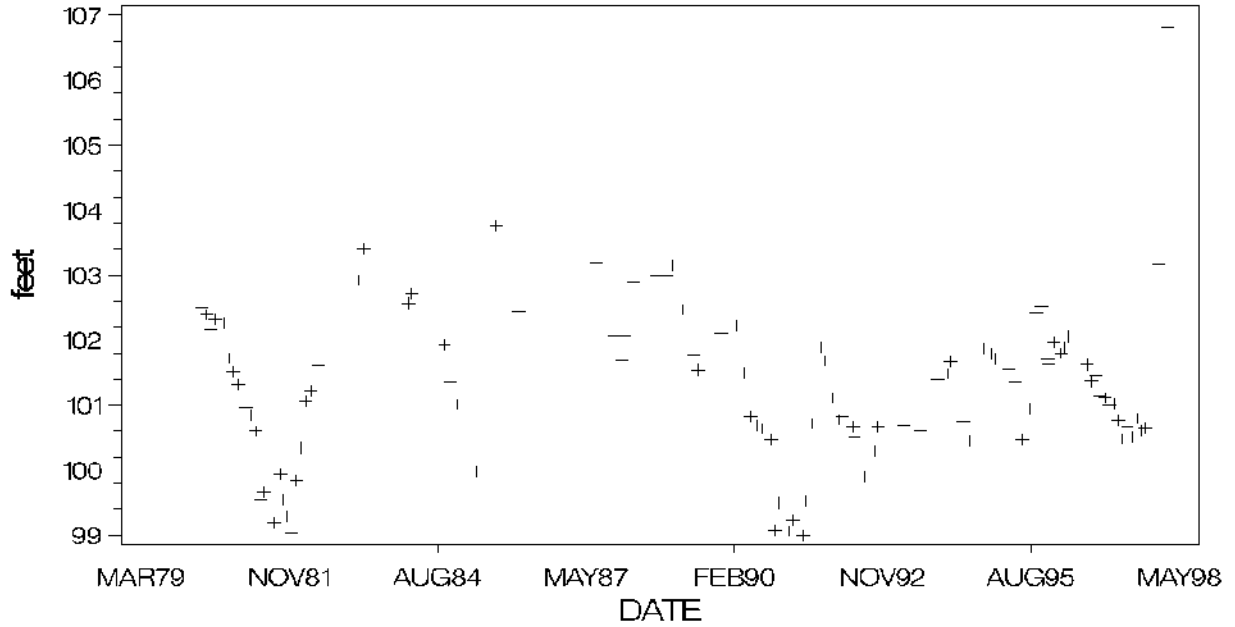

MAJOR IONS (% meq/l)

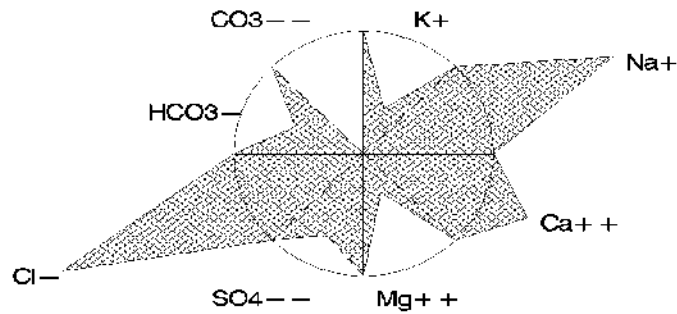

White Trout Lake Hillsborough County

USGS Quadrangle: Sulphur Springs Major Land Use/Land Cover (1990)
 Section/Township/Range: 22-28S-18E within 500 meters of the lakeshore:
 Approx. Lake Center, Lat/Long: 280221/822946 - high density residential (39%)
 Surface Area: 77 acres - medium density residential (14%)
 Approx. Lake Elevation: 37 feet - low density residential (12%)
 Lake Type: inflow and outflow (type 3)
 Major Basin: Tampa Bay Drainage
 Minor Basin: Sweetwater Creek
 Lake Region: Land-o-Lakes

Total Number of Samples Collected: 2 Most Recent Sample Collected: January 1995

Parameter	Units (Detection Limit)	Average Value	District Percentile	Florida Percentile
Chlorophyll a	ug/l (1)	3.4	30	14
Total Phosphorus	mg/l as P (0.01)	0.009	31	<5
Total Nitrogen	mg/l as N (0.06)	0.60	8	15
Transparency (Secchi depth)	meters	3.15	87	>95
Florida Trophic State Index		26	19	<5
Specific Conductance	S/cm at 25C (1)	201	59	52
pH	standard units (0.1)	7.4	57	50
Color	PtCo units (1)	5	9	5
Turbidity	NTU (1)	1.3	36	10
Total Alkalinity	mg/l as CaCO3 (1)	30	58	49
Hardness	mg/l as CaCO3 (0.02)	60	62	
Total Suspended Solids	mg/l (0.05)	0.6	15	
Ammonia	mg/l as N (0.03)	0.015	60	
Nitrate+Nitrite	mg/l as N (0.01)	0.041	66	
Total Kjeldahl Nitrogen	mg/l as N (0.06)	0.56	12	
Orthophosphorus	mg/l as P (0.01)	0.005	56	
Chloride	mg/l (0.05)	23	69	
Sulfate	mg/l (0.05)	24	69	
Sodium	mg/l (0.06)	10.5	62	
Potassium	mg/l (0.07)	2.6	42	
Calcium	mg/l (0.04)	20.0	75	
Magnesium	mg/l (0.006)	2.5	36	
Iron	ug/l (0.03)	16	11	

Based upon the average FTSI of 26, water quality is considered good. White Trout Lake can be characterized as a clear (color<=10 color units), soft water, oligo-mesotrophic lake, with low concentrations of total phosphorus, very low concentrations of total nitrogen. The chemical type of water (predominant ionic composition) is calcium chloride.

Plots and Trends: No trends are evident in the plots of lake surface elevation and specific conductance. Also shown is a diagram of the relative ionic composition of the lake water.

MONTHLY AVERAGE SURFACE ELEVATION

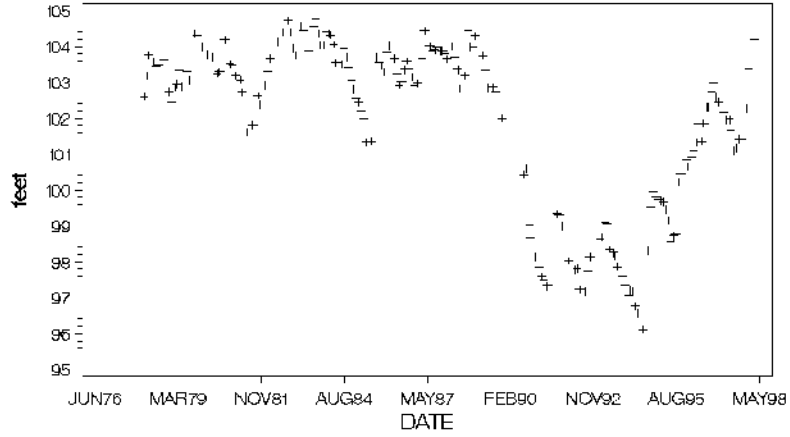

SPEC. CONDUCTANCE

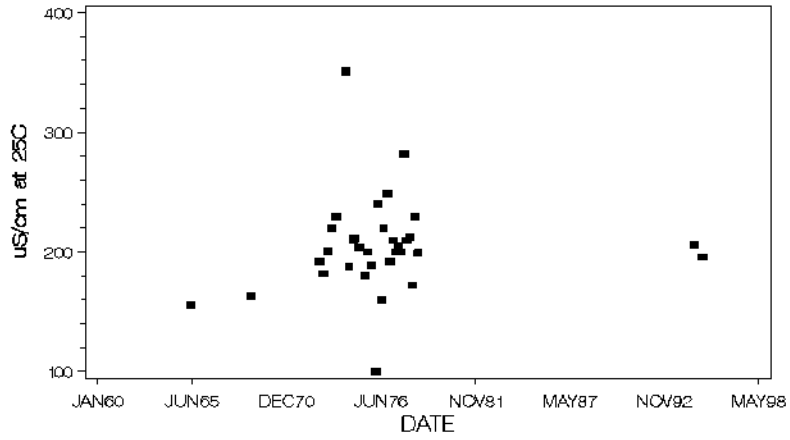

MAJOR IONS (% meq/l)

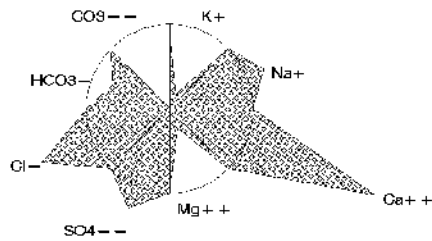

White Trout Lake, Hillsborough County

Williams Lake Hillsborough County

USGS Quadrangle: Citrus Park Major Land Use/Land Cover (1990)
 Section/Township/Range: 33-27S-17E within 500 meters of the lakeshore:
 Approx. Lake Center, Lat/Long: 280555/823611 - medium density residential (33%)
 Surface Area: 15 acres - tree crops, typically citrus (15%)
 Approx. Lake Elevation: 32 feet - cropland and pastureland (14%)
 Lake Type: isolated (type 4)
 Major Basin: Tampa Bay Drainage
 Minor Basin: Unnamed Ditch
 Lake Region: Keystone Lakes

Total Number of Samples Collected: 2 Most Recent Sample Collected: February 1997

Parameter	Units (Detection Limit)	Average Value	District Percentile	Florida Percentile
Chlorophyll a	ug/l (1)	4.0	36	16
Total Phosphorus	mg/l as P (0.01)	0.005	31	<5
Total Nitrogen	mg/l as N (0.06)	0.94	36	31
Transparency (Secchi depth)	meters	2.59	76	92
Florida Trophic State Index		27	21	<5
Specific Conductance	S/cm at 25C (1)	161	43	44
pH	standard units (0.1)	6.6	18	20
Color	PtCo units (1)	20	55	17
Turbidity	NTU (1)	1.0	29	5
Total Alkalinity	mg/l as CaCO3 (1)	14	33	32
Hardness	mg/l as CaCO3 (0.02)	37	30	
Total Suspended Solids	mg/l (0.05)	0.5	11	
Ammonia	mg/l as N (0.03)	0.015	60	
Nitrate+Nitrite	mg/l as N (0.01)	0.005	33	
Total Kjeldahl Nitrogen	mg/l as N (0.06)	0.94	42	
Orthophosphorus	mg/l as P (0.01)	0.005	56	
Chloride	mg/l (0.05)	23	69	
Sulfate	mg/l (0.05)	20	61	
Sodium	mg/l (0.06)	12.5	73	
Potassium	mg/l (0.07)	4.7	64	
Calcium	mg/l (0.04)	9.3	36	
Magnesium	mg/l (0.006)	3.4	50	
Iron	ug/l (0.03)	33	44	

Based upon the average FTSI of 27, water quality is considered good. Williams Lake can be characterized as a moderately colored, soft water, mesotrophic lake, with low concentrations of total phosphorus. The chemical type of water (predominant ionic composition) is sodium chloride.

Also of note:

- Cattails dominate more than 30% of the lake shoreline.

Plots and Trends: No or insufficient data available for plotting or trend detection. Shown is a diagram of the relative ionic composition of the lake water.

MAJOR IONS (% meq/l)

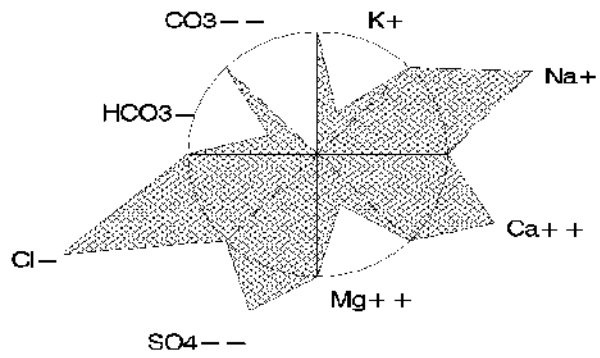

Williams Lake, Hillsborough County

Lake Wimauma

Hillsborough County

USGS Quadrangle: Wimauma Major Land Use/Land Cover (1990)
 Section/Township/Range: 9-32S-20E within 500 meters of the lakeshore:
 Approx. Lake Center, Lat/Long: 274229/821845 - low density residential (30%)
 Surface Area: 135 acres - cropland and pastureland (30%)
 Approx. Lake Elevation: 87 feet - medium density residential (12%)
 Average Depth: 8.7 feet
 Observed Maximum Depth: 23 feet
 (reference elevation 81.8 feet)
 Lake Type: isolated (type 4)
 Major Basin: Little Manatee River
 Minor Basin: Lake Wimauma Drain
 Lake Region: Wimauma Lakes

Total Number of Samples Collected: 2 Most Recent Sample Collected: January 1996

Parameter	Units (Detection Limit)	Average Value	District Percentile	Florida Percentile
Chlorophyll a	ug/l (1)	2.2	14	9
Total Phosphorus	mg/l as P (0.01)	0.011	38	6
Total Nitrogen	mg/l as N (0.06)	0.83	27	27
Transparency (Secchi depth)	meters	2.13	69	87
Florida Trophic State Index		30	27	<5
Specific Conductance	S/cm at 25C (1)	112	16	28
pH	standard units (0.1)	6.0	5	8
Color	PtCo units (1)	8	24	8
Turbidity	NTU (1)	1.5	41	13
Total Alkalinity	mg/l as CaCO3 (1)	2	<5	5
Hardness	mg/l as CaCO3 (0.02)	26	16	
Total Suspended Solids	mg/l (0.05)	1.2	33	
Ammonia	mg/l as N (0.03)	0.038	67	
Nitrate+Nitrite	mg/l as N (0.01)	0.005	33	
Total Kjeldahl Nitrogen	mg/l as N (0.06)	0.82	33	
Orthophosphorus	mg/l as P (0.01)	0.005	56	
Chloride	mg/l (0.05)	15	34	
Sulfate	mg/l (0.05)	22	65	
Sodium	mg/l (0.06)	7.8	42	
Potassium	mg/l (0.07)	2.9	46	
Calcium	mg/l (0.04)	5.8	18	
Magnesium	mg/l (0.006)	2.8	41	
Iron	ug/l (0.03)	67	71	

Based upon the average FTSI of 30, water quality is considered good. Lake Wimauma can be characterized as a clear (color<=10 color units), soft water, oligotrophic lake, with low concentrations of total nitrogen. The chemical type of water (predominant ionic composition) is sodium sulfate.

Also of note:

- The measured pH was low.
- Cattails dominate more than 30% of the lake shoreline.

Plots and Trends: Lake levels in Lake Wimauma have fluctuated over a range of over 12 feet. Also shown is a diagram of the relative ionic composition of the lake water.

MONTHLY AVERAGE SURFACE ELEVATION

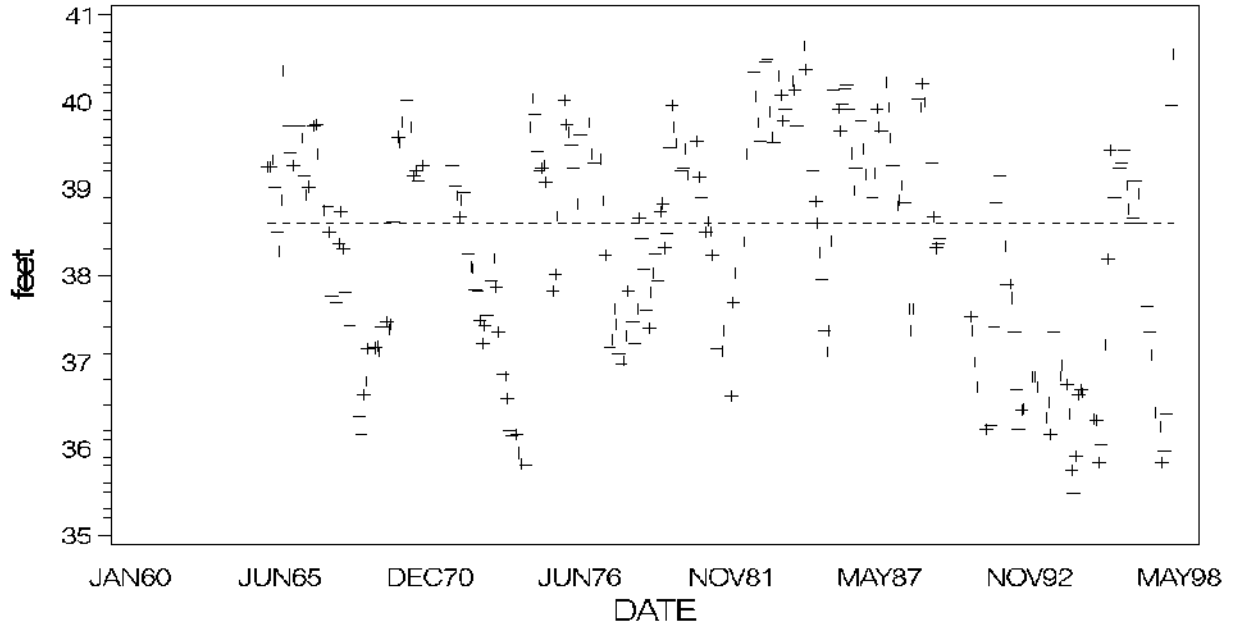

MAJOR IONS (% meq/l)

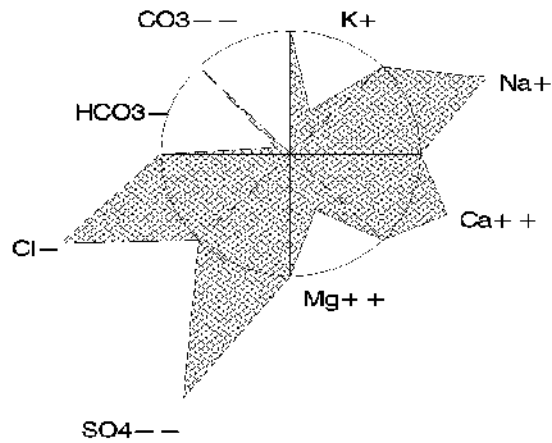

Lake Wimauma, Hillsborough County

Wood Lake Hillsborough County

USGS Quadrangle: Odessa Major Land Use/Land Cover (1990)
 Section/Township/Range: 11-27S-17E within 500 meters of the lakeshore:
 Approx. Lake Center, Lat/Long: 280917/823439 - medium density residential (32%)
 Surface Area: 18 acres - tree crops, typically citrus (19%)
 Approx. Lake Elevation: 46 feet - other open lands - rural (18%)
 Lake Type: inflow and outflow (type 3)
 Major Basin: Tampa Bay Drainage
 Minor Basin: Brooker Creek
 Lake Region: Keystone Lakes

Total Number of Samples Collected: 2 Most Recent Sample Collected: January 1996

Parameter	Units (Detection Limit)	Average Value	District Percentile	Florida Percentile
Chlorophyll a	ug/l (1)	1.5	5	5
Total Phosphorus	mg/l as P (0.01)	0.008	31	<5
Total Nitrogen	mg/l as N (0.06)	1.07	46	36
Transparency (Secchi depth)	meters		-	-
Florida Trophic State Index		18	<5	<5
Specific Conductance	S/cm at 25C (1)	134	27	37
pH	standard units (0.1)	6.8	25	25
Color	PtCo units (1)	8	24	8
Turbidity	NTU (1)	0.5	28	<5
Total Alkalinity	mg/l as CaCO3 (1)	4	10	10
Hardness	mg/l as CaCO3 (0.02)	30	21	
Total Suspended Solids	mg/l (0.05)	0.3	<5	
Ammonia	mg/l as N (0.03)	0.015	60	
Nitrate+Nitrite	mg/l as N (0.01)	0.046	68	
Total Kjeldahl Nitrogen	mg/l as N (0.06)	1.02	49	
Orthophosphorus	mg/l as P (0.01)	0.008	56	
Chloride	mg/l (0.05)	17	41	
Sulfate	mg/l (0.05)	24	69	
Sodium	mg/l (0.06)	9.8	57	
Potassium	mg/l (0.07)	3.2	48	
Calcium	mg/l (0.04)	7.3	26	
Magnesium	mg/l (0.006)	2.9	43	
Iron	ug/l (0.03)	42	55	

Based upon the average FTSI of 18, water quality is considered good. Wood Lake can be characterized as a clear (color<=10 color units), soft water, oligotrophic lake, with low concentrations of total phosphorus. The chemical type of water (predominant ionic composition) is calcium chloride (1 sample) or sodium sulfate (1 sample).

Plots and Trends: No or insufficient data available for plotting or trend detection. Shown is a diagram of the relative ionic composition of the lake water.

MAJOR IONS (% meq/l)

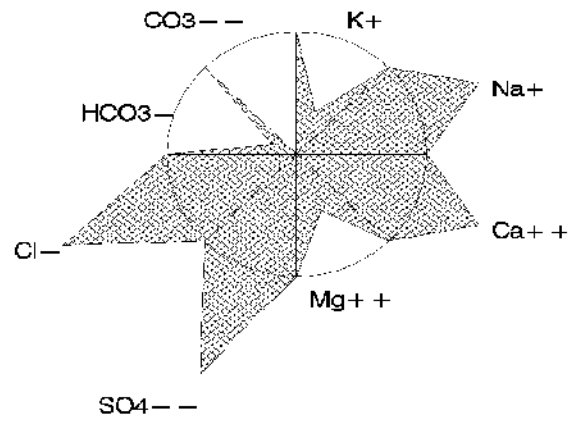

Zambito Lake

Hillsborough County

USGS Quadrangle: Sulphur Springs Major Land Use/Land Cover (1990)
 Section/Township/Range: 22-27S-18E within 500 meters of the lakeshore:
 Approx. Lake Center, Lat/Long: 280650/822929 - high density residential (43%)
 Surface Area: 17 acres - medium density residential (21%)
 Approx. Lake Elevation: 54 feet - wetland forested mixed (11%)
 Lake Type: inflow and outflow (type 3)
 Major Basin: Tampa Bay Drainage
 Minor Basin: Drainage Canal
 Lake Region: Land-o-Lakes

Total Number of Samples Collected: 2 Most Recent Sample Collected: January 1995

Parameter	Units (Detection Limit)	Average Value	District Percentile	Florida Percentile
Chlorophyll a	ug/l (1)	6.3	51	27
Total Phosphorus	mg/l as P (0.01)	0.012	41	6
Total Nitrogen	mg/l as N (0.06)	1.76	77	73
Transparency (Secchi depth)	meters	1.30	45	72
Florida Trophic State Index		40	52	15
Specific Conductance	S/cm at 25C (1)	133	26	36
pH	standard units (0.1)	6.9	29	28
Color	PtCo units (1)	40	72	30
Turbidity	NTU (1)	1.0	29	5
Total Alkalinity	mg/l as CaCO3 (1)	21	43	40
Hardness	mg/l as CaCO3 (0.02)	38	32	
Total Suspended Solids	mg/l (0.05)	1.2	33	
Ammonia	mg/l as N (0.03)	0.023	60	
Nitrate+Nitrite	mg/l as N (0.01)	0.045	67	
Total Kjeldahl Nitrogen	mg/l as N (0.06)	1.71	83	
Orthophosphorus	mg/l as P (0.01)	0.009	56	
Chloride	mg/l (0.05)	15	34	
Sulfate	mg/l (0.05)	11	39	
Sodium	mg/l (0.06)	7.0	33	
Potassium	mg/l (0.07)	4.6	62	
Calcium	mg/l (0.04)	12.0	48	
Magnesium	mg/l (0.006)	1.9	23	
Iron	ug/l (0.03)	63	70	

Based upon the average FTSI of 40, water quality is considered good. Zambito Lake can be characterized as a moderately colored, soft water, mesotrophic lake. The chemical type of water (predominant ionic composition) is calcium chloride.

Plots and Trends: No or insufficient data available for plotting or trend detection. Shown is a diagram of the relative ionic composition of the lake water.

MAJOR IONS (% meq/l)

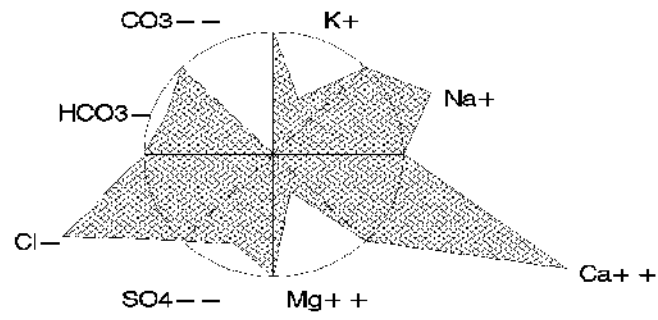

Zambito Lake, Hillsborough County

Lake Marion

Levy County

USGS Quadrangle: Bronson SE Major Land Use/Land Cover (1990)
 Section/Township/Range: 2-14S-17E within 500 meters of the lakeshore:
 Approx. Lake Center, Lat/Long: 291743/823434 - cropland and pastureland (72%)
 Surface Area: 74 acres - wet prairies (17%)
 Approx. Lake Elevation: 51 feet - freshwater marshes (6%)
 Lake Type: isolated (type 4)
 Major Basin: Waccasassa River
 Minor Basin: Wekiva River
 Lake Region: Northern Brooksville Ridge

Total Number of Samples Collected: 2 Most Recent Sample Collected: January 1995

Parameter	Units (Detection Limit)	Average Value	District Percentile	Florida Percentile
Chlorophyll a	ug/l (1)	9.7	62	37
Total Phosphorus	mg/l as P (0.01)	0.005	31	<5
Total Nitrogen	mg/l as N (0.06)	1.96	84	81
Transparency (Secchi depth)	meters	-	-	-
Florida Trophic State Index		43	59	21
Specific Conductance	S/cm at 25C (1)	25	<5	<5
pH	standard units (0.1)	5.6	<5	<5
Color	PtCo units (1)	18	51	15
Turbidity	NTU (1)	1.3	36	10
Total Alkalinity	mg/l as CaCO3 (1)	2	<5	5
Hardness	mg/l as CaCO3 (0.02)	7	<5	
Total Suspended Solids	mg/l (0.05)	2.0	51	
Ammonia	mg/l as N (0.03)	0.023	60	
Nitrate+Nitrite	mg/l as N (0.01)	0.005	33	
Total Kjeldahl Nitrogen	mg/l as N (0.06)	1.95	89	
Orthophosphorus	mg/l as P (0.01)	0.026	89	
Chloride	mg/l (0.05)	4	<5	
Sulfate	mg/l (0.05)	2	10	
Sodium	mg/l (0.06)	1.5	<5	
Potassium	mg/l (0.07)	0.2	<5	
Calcium	mg/l (0.04)	1.3	<5	
Magnesium	mg/l (0.006)	0.8	<5	
Iron	ug/l (0.03)	14	8	

Based upon the average FTSI of 43, water quality is considered good. Lake Marion can be characterized as a clear to moderately colored (10<color<20 color units), soft water, mesotrophic lake, with low concentrations of total phosphorus and high concentrations of total nitrogen. The chemical type of water (predominant ionic composition) is calcium chloride (1 sample) or sodium chloride (1 sample).

Also of note:

- The measured pH was low.

Plots and Trends: No or insufficient data available for plotting or trend detection. Shown is a diagram of the relative ionic composition of the lake water.

MAJOR IONS (% meq/l)

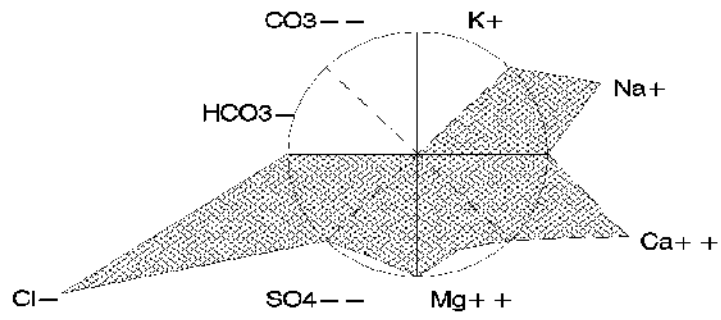

Lake Marion, Levy County

Bonable Lake Marion County

USGS Quadrangle: Tidewater
 Section/Township/Range: 31-15S-18E
 Approx. Lake Center, Lat/Long: 290815/823123
 Surface Area: 211 acres
 Approx. Lake Elevation: 68 feet
 Lake Type: inflow and outflow (type 3)
 Major Basin: Waccasassa River
 Minor Basin: Sand Slough
 Lake Region: Northern Brooksville Ridge
 Public Access: yes

Major Land Use/Land Cover (1990)
 within 500 meters of the lakeshore:
 - open land (20%)
 - cropland and pastureland (19%)
 - low density residential (17%)

Total Number of Samples Collected: 2 Most Recent Sample Collected: January 1995

Parameter	Units (Detection Limit)	Average Value	District Percentile	Florida Percentile
Chlorophyll a	ug/l (1)	11.7	69	41
Total Phosphorus	mg/l as P (0.01)	0.038	82	28
Total Nitrogen	mg/l as N (0.06)	1.55	71	63
Transparency (Secchi depth)	meters	0.55	13	25
Florida Trophic State Index		63	86	60
Specific Conductance	S/cm at 25C (1)	51	<5	5
pH	standard units (0.1)	6.5	15	18
Color	PtCo units (1)	78	85	65
Turbidity	NTU (1)	10.2	88	70
Total Alkalinity	mg/l as CaCO3 (1)	4	10	10
Hardness	mg/l as CaCO3 (0.02)	12	<5	
Total Suspended Solids	mg/l (0.05)	6.4	84	
Ammonia	mg/l as N (0.03)	0.027	60	
Nitrate+Nitrite	mg/l as N (0.01)	0.053	71	
Total Kjeldahl Nitrogen	mg/l as N (0.06)	1.50	77	
Orthophosphorus	mg/l as P (0.01)	0.031	90	
Chloride	mg/l (0.05)	6	5	
Sulfate	mg/l (0.05)	7	27	
Sodium	mg/l (0.06)	3.6	6	
Potassium	mg/l (0.07)	0.3	7	
Calcium	mg/l (0.04)	3.1	6	
Magnesium	mg/l (0.006)	0.9	<5	
Iron	ug/l (0.03)	102	82	

Based upon the average FTSI of 63, water quality is considered fair. Bonable Lake can be characterized as a colored, soft water, meso-eutrophic lake, with high concentrations of total phosphorus. The chemical type of water (predominant ionic composition) is calcium chloride (1 sample) or sodium sulfate (1 sample).

Plots and Trends: No or insufficient data for plotting or trend detection. Shown is a diagram of the relative ionic composition of the lake water.

MAJOR IONS (% meq/l)

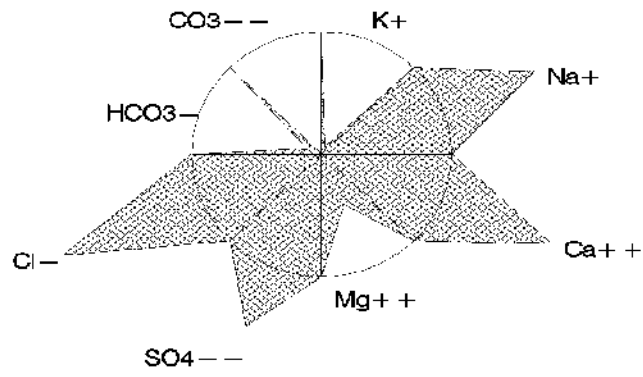

Bonable Lake, Marion County

Little Bream Lake

Marion County

USGS Quadrangle:	Yankeetown SE	Major Land Use/Land Cover (1990)
Section/Township/Range:	19-16S-18E	within 500 meters of the lakeshore:
Approx. Lake Center, Lat/Long:	290438/823158	- upland coniferous forests (50%)
Surface Area:	19 acres	- cropland and pastureland (17%)
Approx. Lake Elevation:	73 feet	- other open lands - rural (13%)
Lake Type:	isolated (type 4)	
Major Basin:	Withlacoochee River	
Minor Basin:	Bell Branch	
Lake Region:	Gulf Coast Lowlands	

Total Number of Samples Collected: 2 Most Recent Sample Collected: January 1995

Parameter	Units (Detection Limit)	Average Value	District Percentile	Florida Percentile
Chlorophyll a	ug/l (1)	1.9	11	8
Total Phosphorus	mg/l as P (0.01)	0.013	46	7
Total Nitrogen	mg/l as N (0.06)	1.41	67	51
Transparency (Secchi depth)	meters	2.35	73	90
Florida Trophic State Index		26	16	<5
Specific Conductance	S/cm at 25C (1)	40	<5	<5
pH	standard units (0.1)	6.5	15	18
Color	PtCo units (1)	40	72	30
Turbidity	NTU (1)	0.5	28	<5
Total Alkalinity	mg/l as CaCO3 (1)	8	21	22
Hardness	mg/l as CaCO3 (0.02)	15	5	
Total Suspended Solids	mg/l (0.05)	0.8	21	
Ammonia	mg/l as N (0.03)	0.104	88	
Nitrate+Nitrite	mg/l as N (0.01)	0.005	33	
Total Kjeldahl Nitrogen	mg/l as N (0.06)	1.40	75	
Orthophosphorus	mg/l as P (0.01)	0.005	56	
Chloride	mg/l (0.05)	4	<5	
Sulfate	mg/l (0.05)	3	14	
Sodium	mg/l (0.06)	2.0	<5	
Potassium	mg/l (0.07)	0.1	<5	
Calcium	mg/l (0.04)	4.9	14	
Magnesium	mg/l (0.006)	0.6	<5	
Iron	ug/l (0.03)	57	66	

Based upon the average FTSI of 26, water quality is considered good. Little Bream Lake can be characterized as a colored, soft water, oligotrophic lake. The chemical type of water (predominant ionic composition) is calcium bicarbonate (1 sample) or calcium chloride.

Plots and Trends: No or insufficient data available for plotting or trend detection. Shown is a diagram of the relative ionic composition of the lake water.

MAJOR IONS (% meq/l)

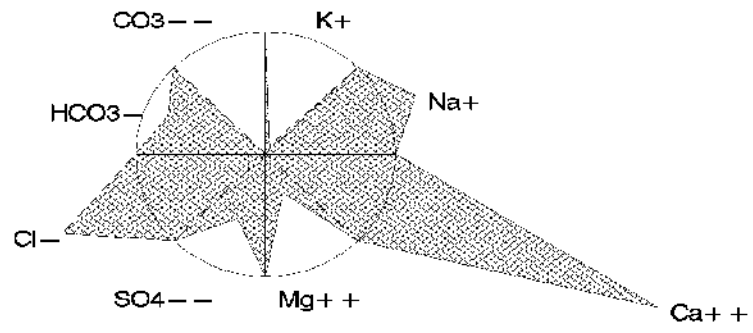

Little Bream Lake, Marion County

Little Bonable Lake

Marion County

USGS Quadrangle: Tidewater Major Land Use/Land Cover (1990)
 Section/Township/Range: 30-15S-18E within 500 meters of the lakeshore:
 Approx. Lake Center, Lat/Long: 290906/823153 - cropland and pastureland (31%)
 Surface Area: 157 acres - open land (23%)
 Approx. Lake Elevation: 58 feet - freshwater marshes (12%)
 Lake Type: outflow (type 2)
 Major Basin: Waccasassa River
 Minor Basin: Sand Slough
 Lake Region: Northern Brooksville Ridge
 Public Access: yes

Total Number of Samples Collected: 2 Most Recent Sample Collected: January 1995

Parameter	Units (Detection Limit)	Average Value	District Percentile	Florida Percentile
Chlorophyll a	ug/l (1)	21.6	80	54
Total Phosphorus	mg/l as P (0.01)	0.044	85	37
Total Nitrogen	mg/l as N (0.06)	2.10	86	83
Transparency (Secchi depth)	meters	0.55	13	25
Florida Trophic State Index		68	92	74
Specific Conductance	S/cm at 25C (1)	55	<5	7
pH	standard units (0.1)	6.7	21	23
Color	PtCo units (1)	45	76	35
Turbidity	NTU (1)	12.8	92	74
Total Alkalinity	mg/l as CaCO3 (1)	4	10	10
Hardness	mg/l as CaCO3 (0.02)	13	<5	
Total Suspended Solids	mg/l (0.05)	9.7	90	
Ammonia	mg/l as N (0.03)	0.043	71	
Nitrate+Nitrite	mg/l as N (0.01)	0.005	33	
Total Kjeldahl Nitrogen	mg/l as N (0.06)	2.09	91	
Orthophosphorus	mg/l as P (0.01)	0.012	68	
Chloride	mg/l (0.05)	6	5	
Sulfate	mg/l (0.05)	8	31	
Sodium	mg/l (0.06)	3.4	5	
Potassium	mg/l (0.07)	1.1	20	
Calcium	mg/l (0.04)	3.7	7	
Magnesium	mg/l (0.006)	1.0	6	
Iron	ug/l (0.03)	73	73	

Based upon the average FTSI of 68, water quality is considered fair. Little Bonable Lake can be characterized as a colored, soft water, eutrophic lake, with high concentrations of total phosphorus and high concentrations of total nitrogen. The chemical type of water (predominant ionic composition) is calcium chloride.

Plots and Trends: No or insufficient data available for plotting or trend detection. Shown is a diagram of the relative ionic composition of the lake water.

MAJOR IONS (% meq/l)

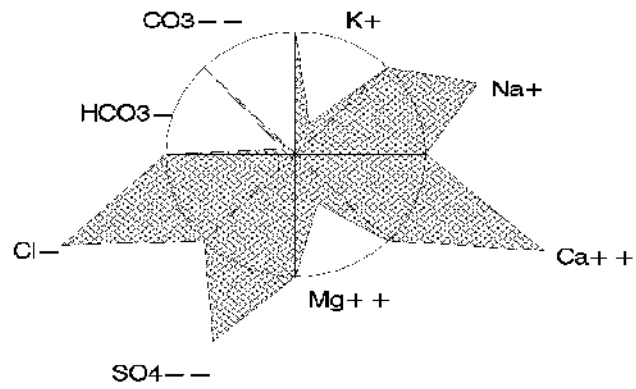

Little Bonable Lake, Marion County

Lake Otting Marion County

USGS Quadrangle:	Dunellon SE	Major Land Use/Land Cover (1990)
Section/Township/Range:	30-16S-20E	within 500 meters of the lakeshore:
Approx. Lake Center, Lat/Long:	290422/822033	- open land (60%)
Surface Area:	4 acres	- hardwood - conifer mixed (18%)
Approx. Lake Elevation:	45 feet	- low density residential (18%)
Lake Type:	isolated (type 4)	
Major Basin:	Withlacoochee River	
Minor Basin:	Withlacoochee River	
Lake Region:	Tsala Apopka	

Total Number of Samples Collected: 2 Most Recent Sample Collected: January 1996

Parameter	Units (Detection Limit)	Average Value	District Percentile	Florida Percentile
Chlorophyll a	ug/l (1)	9.2	60	36
Total Phosphorus	mg/l as P (0.01)	0.018	61	9
Total Nitrogen	mg/l as N (0.06)	1.13	51	38
Transparency (Secchi depth)	meters		-	-
Florida Trophic State Index		47	67	28
Specific Conductance	S/cm at 25C (1)	149	38	42
pH	standard units (0.1)	7.4	57	50
Color	PtCo units (1)	8	24	8
Turbidity	NTU (1)	1.6	44	14
Total Alkalinity	mg/l as CaCO3 (1)	73	93	74
Hardness	mg/l as CaCO3 (0.02)	74	75	
Total Suspended Solids	mg/l (0.05)	2.0	51	
Ammonia	mg/l as N (0.03)	0.125	91	
Nitrate+Nitrite	mg/l as N (0.01)	0.037	63	
Total Kjeldahl Nitrogen	mg/l as N (0.06)	1.09	54	
Orthophosphorus	mg/l as P (0.01)	0.005	56	
Chloride	mg/l (0.05)	2	<5	
Sulfate	mg/l (0.05)	0	<5	
Sodium	mg/l (0.06)	1.1	<5	
Potassium	mg/l (0.07)	0.1	<5	
Calcium	mg/l (0.04)	28.0	90	
Magnesium	mg/l (0.006)	0.8	<5	
Iron	ug/l (0.03)	84	77	

Based upon the average FTSI of 47, water quality is considered good. Lake Otting can be characterized as a clear (color<=10 color units), medium hard water, meso-eutrophic lake. The chemical type of water (predominant ionic composition) is calcium bicarbonate.

Also of note:

- Hydrilla was observed in the lake.

Plots and Trends: No or insufficient data available for plotting or trend detection. Shown is a diagram of the relative ionic composition of the lake water.

MAJOR IONS (% meq/l)

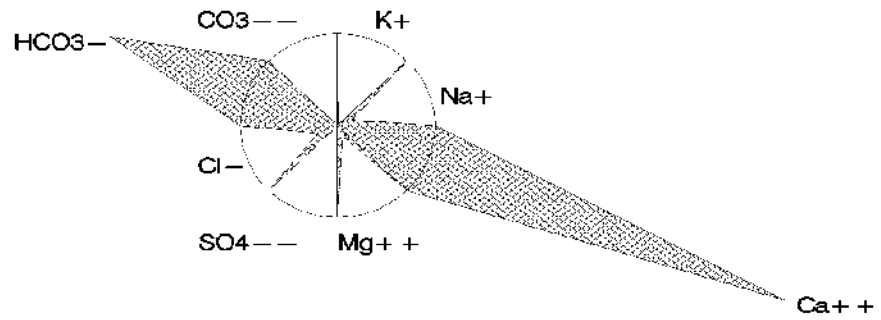

Tiger Lake

Marion County

USGS Quadrangle: Tidewater Major Land Use/Land Cover (1990)
 Section/Township/Range: 32-15S-18E within 500 meters of the lakeshore:
 Approx. Lake Center, Lat/Long: 290751/823101 - low density residential (33%)
 Surface Area: 77 acres - open land (25%)
 Approx. Lake Elevation: 68 feet - cropland and pastureland (14%)
 Average Depth: 5.9 feet
 Observed Maximum Depth: 12 feet
 (reference elevation 57.4 feet)
 Lake Type: outflow (type 2)
 Major Basin: Waccasassa River
 Minor Basin: Sand Slough
 Lake Region: Northern Brooksville Ridge
 Public Access: yes

Total Number of Samples Collected: 2 Most Recent Sample Collected: January 1995

Parameter	Units (Detection Limit)	Average Value	District Percentile	Florida Percentile
Chlorophyll a	ug/l (1)	6.9	52	30
Total Phosphorus	mg/l as P (0.01)	0.022	68	12
Total Nitrogen	mg/l as N (0.06)	1.05	45	35
Transparency (Secchi depth)	meters	1.05	36	65
Florida Trophic State Index		46	63	26
Specific Conductance	S/cm at 25C (1)	49	<5	<5
pH	standard units (0.1)	6.1	6	9
Color	PtCo units (1)	18	51	15
Turbidity	NTU (1)	6.6	80	58
Total Alkalinity	mg/l as CaCO3 (1)	2	<5	5
Hardness	mg/l as CaCO3 (0.02)	12	<5	
Total Suspended Solids	mg/l (0.05)	5.5	80	
Ammonia	mg/l as N (0.03)	0.027	60	
Nitrate+Nitrite	mg/l as N (0.01)	0.030	59	
Total Kjeldahl Nitrogen	mg/l as N (0.06)	1.01	48	
Orthophosphorus	mg/l as P (0.01)	0.009	56	
Chloride	mg/l (0.05)	6	5	
Sulfate	mg/l (0.05)	8	31	
Sodium	mg/l (0.06)	3.4	5	
Potassium	mg/l (0.07)	0.3	7	
Calcium	mg/l (0.04)	3.3	6	
Magnesium	mg/l (0.006)	0.8	<5	
Iron	ug/l (0.03)	50	60	

Based upon the average FTSI of 46, water quality is considered good. Tiger Lake can be characterized as a clear to moderately colored (10<color<20 color units), soft water, meso-eutrophic lake. The chemical type of water (predominant ionic composition) is calcium chloride (1 sample) or sodium chloride (1 sample).

Plots and Trends: No or insufficient data available for plotting or trend detection. Shown is a diagram of the relative ionic composition of the lake water.

MAJOR IONS (% meq/l)

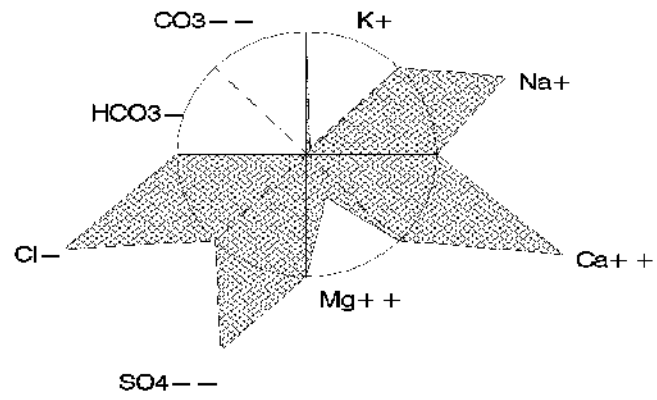

Tiger Lake, Marion County

Banjo Lake

Pasco County

USGS Quadrangle: Lutz Major Land Use/Land Cover (1990)
 Section/Township/Range: 18-26S-19E within 500 meters of the lakeshore:
 Approx. Lake Center, Lat/Long: 281309/822632 - other open lands - rural (58%)
 Surface Area: 11 acres - low density residential (8%)
 Approx. Lake Elevation: 73 feet - medium density residential (7%)
 Lake Type: outflow (type 2)
 Major Basin: Hillsborough River
 Minor Basin: Banjo Lake Outlet
 Lake Region: Land-o-Lakes

Total Number of Samples Collected: 2 Most Recent Sample Collected: January 1996

Parameter	Units (Detection Limit)	Average Value	District Percentile	Florida Percentile
Chlorophyll a	ug/l (1)	31.4	86	66
Total Phosphorus	mg/l as P (0.01)	0.005	31	<5
Total Nitrogen	mg/l as N (0.06)	2.08	86	82
Transparency (Secchi depth)	meters	0.80	24	50
Florida Trophic State Index		59	82	52
Specific Conductance	S/cm at 25C (1)	231	71	57
pH	standard units (0.1)	7.8	74	63
Color	PtCo units (1)	55	80	45
Turbidity	NTU (1)	4.3	72	44
Total Alkalinity	mg/l as CaCO3 (1)	62	87	69
Hardness	mg/l as CaCO3 (0.02)	72	74	
Total Suspended Solids	mg/l (0.05)	4.4	75	
Ammonia	mg/l as N (0.03)	0.104	88	
Nitrate+Nitrite	mg/l as N (0.01)	0.059	72	
Total Kjeldahl Nitrogen	mg/l as N (0.06)	2.02	90	
Orthophosphorus	mg/l as P (0.01)	0.005	56	
Chloride	mg/l (0.05)	22	64	
Sulfate	mg/l (0.05)	13	45	
Sodium	mg/l (0.06)	16.5	87	
Potassium	mg/l (0.07)	3.7	51	
Calcium	mg/l (0.04)	23.0	84	
Magnesium	mg/l (0.006)	3.6	54	
Iron	ug/l (0.03)	105	83	

Based upon the average FTSI of 59, water quality is considered good. Banjo Lake can be characterized as a colored, medium hard water, eutrophic lake, with low concentrations of total phosphorus and high concentrations of total nitrogen. The chemical type of water (predominant ionic composition) is calcium bicarbonate (1 sample) or calcium chloride (1 sample).

Plots and Trends: No or insufficient data for plotting or trend detection. Shown is a diagram of the relative ionic composition of the lake water.

MAJOR IONS (% meq/l)

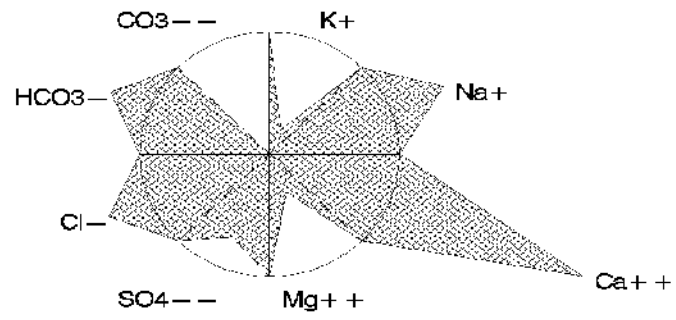

Banjo Lake, Pasco County

Bell Lake

Pasco County

USGS Quadrangle: Lutz Major Land Use/Land Cover (1990)
 Section/Township/Range: 13-26S-18E within 500 meters of the lakeshore:
 Approx. Lake Center, Lat/Long: 281317/822714 - medium density residential (38%)
 Surface Area: 80 acres - cropland and pastureland (20%)
 Approx. Lake Elevation: 73 feet - commercial and services (10%)
 Average Depth: 7.2 feet
 Observed Maximum Depth: 20 feet
 (reference elevation not given)
 Lake Type: inflow and outflow (type 3)
 Major Basin: Hillsborough River
 Minor Basin: Lake Hanna Outlet
 Lake Region: Land-o-Lakes

Total Number of Samples Collected: 2 Most Recent Sample Collected: January 1995

Parameter	Units (Detection Limit)	Average Value	District Percentile	Florida Percentile
Chlorophyll a	ug/l (1)	5.0	44	20
Total Phosphorus	mg/l as P (0.01)	0.013	46	7
Total Nitrogen	mg/l as N (0.06)	0.61	9	16
Transparency (Secchi depth)	meters	1.90	61	83
Florida Trophic State Index		33	37	8
Specific Conductance	S/cm at 25C (1)	217	65	55
pH	standard units (0.1)	7.9	78	67
Color	PtCo units (1)	5	9	5
Turbidity	NTU (1)	1.3	36	10
Total Alkalinity	mg/l as CaCO3 (1)	44	76	59
Hardness	mg/l as CaCO3 (0.02)	63	65	
Total Suspended Solids	mg/l (0.05)	1.5	39	
Ammonia	mg/l as N (0.03)	0.027	60	
Nitrate+Nitrite	mg/l as N (0.01)	0.010	34	
Total Kjeldahl Nitrogen	mg/l as N (0.06)	0.60	15	
Orthophosphorus	mg/l as P (0.01)	0.005	56	
Chloride	mg/l (0.05)	31	87	
Sulfate	mg/l (0.05)	8	31	
Sodium	mg/l (0.06)	16.5	87	
Potassium	mg/l (0.07)	3.4	49	
Calcium	mg/l (0.04)	19.5	74	
Magnesium	mg/l (0.006)	3.4	50	
Iron	ug/l (0.03)	24	29	

Based upon the average FTSI of 33, water quality is considered good. Bell Lake can be characterized as a clear (color<=10 color units), medium hard water, mesotrophic lake, with very low concentrations of total nitrogen. The chemical type of water (predominant ionic composition) is calcium chloride.

Plots and Trends: Shown are a plot of the average monthly surface elevation, and a diagram of the relative ionic composition of the lake water. There is no discernable trend in surface elevation for the period of record.

MONTHLY AVERAGE SURFACE ELEVATION

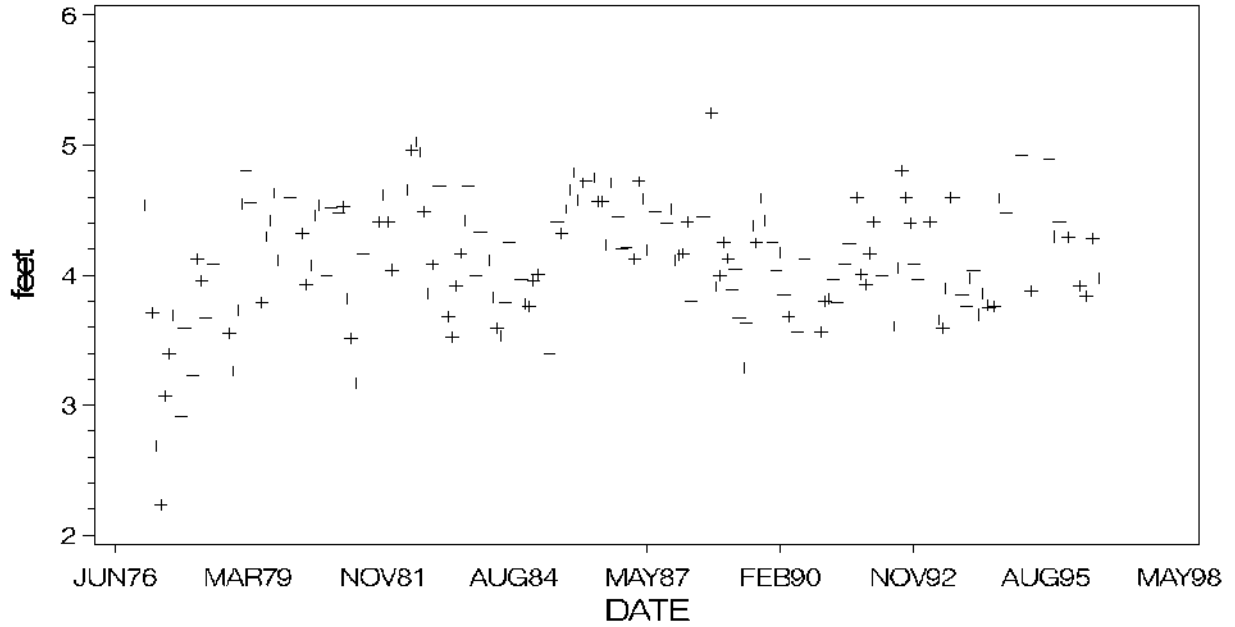

MAJOR IONS (% meq/l)

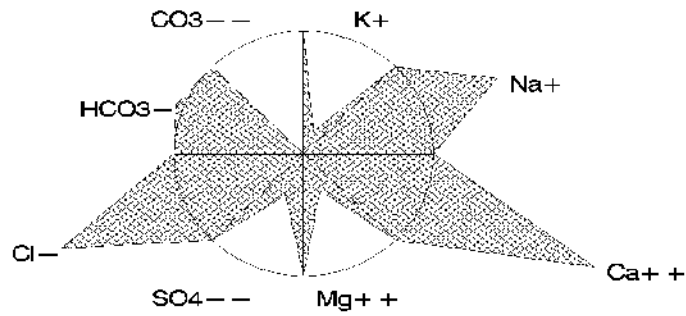

Lake Bernadette

Pasco County

USGS Quadrangle: Zephyrhills Major Land Use/Land Cover (1990)
 Section/Township/Range: 8-26S-21E within 500 meters of the lakeshore:
 Approx. Lake Center, Lat/Long: 281404/821403 - medium density residential (31%)
 Surface Area: 24 acres - recreational (17%)
 Approx. Lake Elevation: 79 feet - open land (10%)
 Lake Type: isolated (type 4)
 Major Basin: Hillsborough River
 Minor Basin: Indian Creek
 Lake Region: Hillsborough Valley

Total Number of Samples Collected: 2 Most Recent Sample Collected: January 1996

Parameter	Units (Detection Limit)	Average Value	District Percentile	Florida Percentile
Chlorophyll a	ug/l (1)	11.3	69	40
Total Phosphorus	mg/l as P (0.01)	0.235	>95	86
Total Nitrogen	mg/l as N (0.06)	1.34	63	47
Transparency (Secchi depth)	meters	0.90	28	60
Florida Trophic State Index		45	62	24
Specific Conductance	S/cm at 25C (1)	204	61	53
pH	standard units (0.1)	7.2	43	40
Color	PtCo units (1)	85	86	70
Turbidity	NTU (1)	1.7	45	16
Total Alkalinity	mg/l as CaCO3 (1)	42	74	57
Hardness	mg/l as CaCO3 (0.02)	62	64	
Total Suspended Solids	mg/l (0.05)	2.6	60	
Ammonia	mg/l as N (0.03)	0.050	75	
Nitrate+Nitrite	mg/l as N (0.01)	0.085	80	
Total Kjeldahl Nitrogen	mg/l as N (0.06)	1.25	65	
Orthophosphorus	mg/l as P (0.01)	0.208	>95	
Chloride	mg/l (0.05)	24	74	
Sulfate	mg/l (0.05)	14	48	
Sodium	mg/l (0.06)	12.0	69	
Potassium	mg/l (0.07)	5.6	70	
Calcium	mg/l (0.04)	21.0	78	
Magnesium	mg/l (0.006)	2.2	31	
Iron	ug/l (0.03)	126	86	

Based upon the average FTSI of 45, water quality is considered good. Lake Bernadette can be characterized as a highly colored, medium hard water, meso-eutrophic lake, with high concentrations of total phosphorus. The chemical type of water (predominant ionic composition) is calcium chloride.

Also of note:

- Cattails dominate more than 30% of the lake shoreline.

Plots and Trends: No or insufficient data for plotting or trend detection. Shown is a diagram of the relative ionic composition of the lake water.

MAJOR IONS (% meq/l)

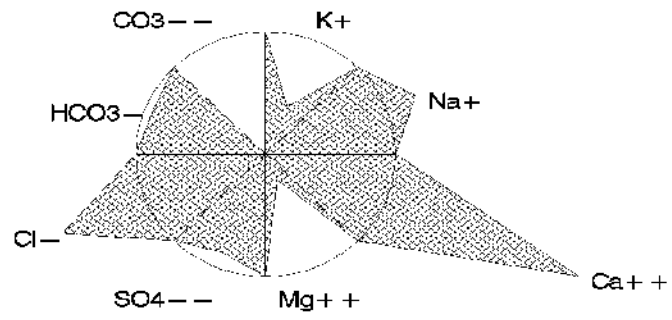

Big Lake Vienna

Pasco County

USGS Quadrangle: Lutz Major Land Use/Land Cover (1990)
 Section/Township/Range: 23-26S-18E within 500 meters of the lakeshore:
 Approx. Lake Center, Lat/Long: 281221/822818 - rowcrops (33%)
 Surface Area: 36 acres - tree crops, typically citrus (17%)
 Approx. Lake Elevation: 70 feet - freshwater marshes (13%)
 Lake Type: outflow (type 2)
 Major Basin: Upper Coastal Drainage
 Minor Basin: South Branch
 Lake Region: Land-o-Lakes

Total Number of Samples Collected: 2 Most Recent Sample Collected: January 1995

Parameter	Units (Detection Limit)	Average Value	District Percentile	Florida Percentile
Chlorophyll a	ug/l (1)	3.1	26	13
Total Phosphorus	mg/l as P (0.01)	0.009	31	<5
Total Nitrogen	mg/l as N (0.06)	0.48	<5	9
Transparency (Secchi depth)	meters	2.00	64	85
Florida Trophic State Index		27	21	<5
Specific Conductance	S/cm at 25C (1)	227	69	56
pH	standard units (0.1)	6.8	25	25
Color	PtCo units (1)	13	41	12
Turbidity	NTU (1)	1.5	41	13
Total Alkalinity	mg/l as CaCO3 (1)	15	36	33
Hardness	mg/l as CaCO3 (0.02)	44	43	
Total Suspended Solids	mg/l (0.05)	1.3	35	
Ammonia	mg/l as N (0.03)	0.040	69	
Nitrate+Nitrite	mg/l as N (0.01)	0.021	53	
Total Kjeldahl Nitrogen	mg/l as N (0.06)	0.46	7	
Orthophosphorus	mg/l as P (0.01)	0.005	56	
Chloride	mg/l (0.05)	37	94	
Sulfate	mg/l (0.05)	30	77	
Sodium	mg/l (0.06)	19.5	92	
Potassium	mg/l (0.07)	6.7	79	
Calcium	mg/l (0.04)	9.5	37	
Magnesium	mg/l (0.006)	4.8	66	
Iron	ug/l (0.03)	15	9	

Based upon the average FTSI of 27, water quality is considered good. Big Lake Vienna can be characterized as a clear to moderately colored (color<=20 color units), soft water, oligo-mesotrophic lake, with low concentrations of total phosphorus, very low concentrations of total nitrogen. The chemical type of water (predominant ionic composition) is sodium chloride.

Plots and Trends: No or insufficient data for plotting or trend detection. Shown is a diagram of the relative ionic composition of the lake water.

MAJOR IONS (% meq/l)

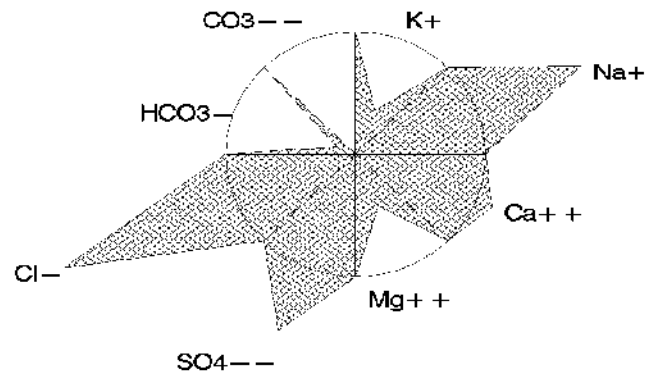

Big Lake Vienna, Pasco County

Bird Lake

Pasco County

USGS Quadrangle: Lutz Major Land Use/Land Cover (1990)
 Section/Township/Range: 36-26S-18E within 500 meters of the lakeshore:
 Approx. Lake Center, Lat/Long: 281050/822713 - freshwater marshes (24%)
 Surface Area: 150 acres - other open lands - rural (18%)
 Approx. Lake Elevation: 68 feet - cypress (12%)
 Average Depth: 5.7 feet
 Observed Maximum Depth: 16.6 feet
 (reference elevation 49.6 feet)
 Lake Type: inflow and outflow (type 3)
 Major Basin: Hillsborough River
 Minor Basin: Lake Hanna Outlet
 Lake Region: Land-o-Lakes

Total Number of Samples Collected: 2 Most Recent Sample Collected: February 1997

Parameter	Units (Detection Limit)	Average Value	District Percentile	Florida Percentile
Chlorophyll a	ug/l (1)	5.2	45	21
Total Phosphorus	mg/l as P (0.01)	0.014	50	7
Total Nitrogen	mg/l as N (0.06)	1.19	54	40
Transparency (Secchi depth)	meters	1.30	45	72
Florida Trophic State Index		35	40	9
Specific Conductance	S/cm at 25C (1)	179	49	48
pH	standard units (0.1)	7.4	57	50
Color	PtCo units (1)	15	46	13
Turbidity	NTU (1)	2.0	51	20
Total Alkalinity	mg/l as CaCO3 (1)	43	75	58
Hardness	mg/l as CaCO3 (0.02)	53	55	
Total Suspended Solids	mg/l (0.05)	1.4	37	
Ammonia	mg/l as N (0.03)	0.015	60	
Nitrate+Nitrite	mg/l as N (0.01)	0.028	58	
Total Kjeldahl Nitrogen	mg/l as N (0.06)	1.17	60	
Orthophosphorus	mg/l as P (0.01)	0.008	56	
Chloride	mg/l (0.05)	22	64	
Sulfate	mg/l (0.05)	8	31	
Sodium	mg/l (0.06)	12.2	71	
Potassium	mg/l (0.07)	2.7	44	
Calcium	mg/l (0.04)	17.6	68	
Magnesium	mg/l (0.006)	2.3	33	
Iron	ug/l (0.03)	17	13	

Based upon the average FTSI of 35, water quality is considered good. Bird Lake can be characterized as a clear to moderately colored (color<=20 color units), soft water, mesotrophic lake. The chemical type of water (predominant ionic composition) is calcium bicarbonate (1 sample) or sodium chloride.

Also of note:

- Melaleuca was observed on the lake shore.
- Cattails dominate more than 30% of the lake shoreline.

Plots and Trends: There is no trend in lake surface elevation for the period of record. Lowest elevations were recorded during the drought years of the early 1990s, but levels have rebounded in recent years. Also shown is a diagram of the relative ionic composition of the lake water.

MONTHLY AVERAGE SURFACE ELEVATION

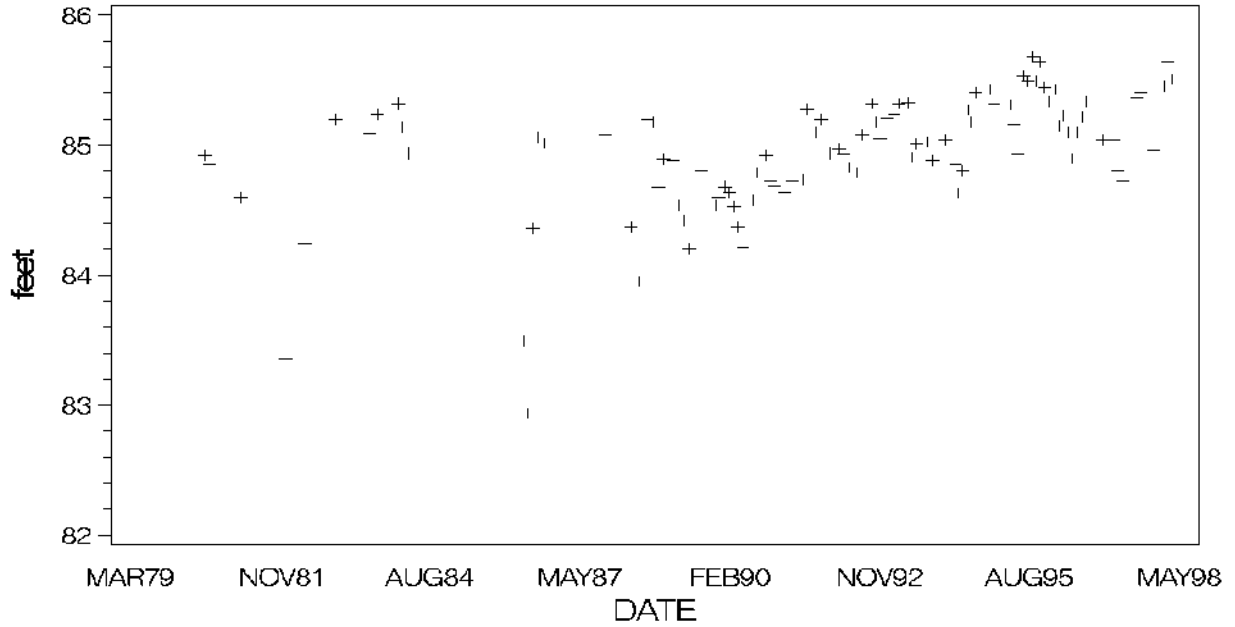

MAJOR IONS (% meq/l)

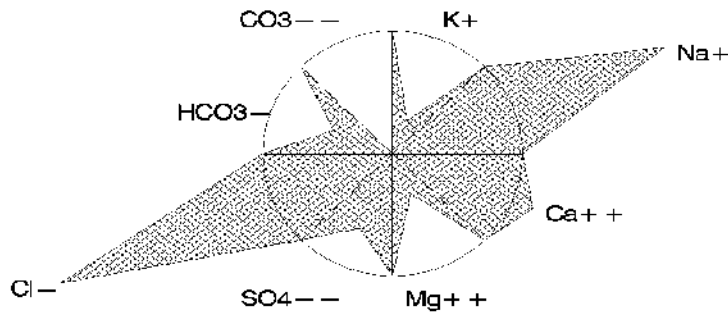

Black Lake

Pasco County

USGS Quadrangle: Odessa Major Land Use/Land Cover (1990)
 Section/Township/Range: 26-26S-17E within 500 meters of the lakeshore:
 Approx. Lake Center, Lat/Long: 281125/823437 - cropland and pastureland (32%)
 Surface Area: 5 acres - stream and lake swamps (22%)
 Approx. Lake Elevation: 49 feet - medium density residential (21%)
 Lake Type: isolated (type 4)
 Major Basin: Upper Coastal Drainage
 Minor Basin: Lake Ann Outlet
 Lake Region: Keystone Lakes

Total Number of Samples Collected: 2 Most Recent Sample Collected: February 1997

Parameter	Units (Detection Limit)	Average Value	District Percentile	Florida Percentile
Chlorophyll a	ug/l (1)	13.7	72	44
Total Phosphorus	mg/l as P (0.01)	0.029	76	19
Total Nitrogen	mg/l as N (0.06)	1.34	63	47
Transparency (Secchi depth)	meters	1.65	54	79
Florida Trophic State Index		46	64	26
Specific Conductance	S/cm at 25C (1)	136	29	38
pH	standard units (0.1)	7.4	57	50
Color	PtCo units (1)	60	82	50
Turbidity	NTU (1)	3.3	65	35
Total Alkalinity	mg/l as CaCO3 (1)	27	54	46
Hardness	mg/l as CaCO3 (0.02)	45	46	
Total Suspended Solids	mg/l (0.05)	3.6	69	
Ammonia	mg/l as N (0.03)	0.015	60	
Nitrate+Nitrite	mg/l as N (0.01)	0.060	72	
Total Kjeldahl Nitrogen	mg/l as N (0.06)	1.29	68	
Orthophosphorus	mg/l as P (0.01)	0.016	82	
Chloride	mg/l (0.05)	12	23	
Sulfate	mg/l (0.05)	13	45	
Sodium	mg/l (0.06)	6.1	23	
Potassium	mg/l (0.07)	4.9	65	
Calcium	mg/l (0.04)	12.0	48	
Magnesium	mg/l (0.006)	3.6	54	
Iron	ug/l (0.03)	28	35	

Based upon the average FTSI of 46, water quality is considered good. Black Lake can be characterized as a colored, soft water, meso-eutrophic lake. The chemical type of water (predominant ionic composition) is calcium chloride (1 sample) or calcium sulfate (1 sample).

Also of note:

- Cattails dominate more than 30% of the lake shoreline.

Plots and Trends: No or insufficient data for plotting or trend detection. Shown is a diagram of the relative ionic composition of the lake water.

MAJOR IONS (% meq/l)

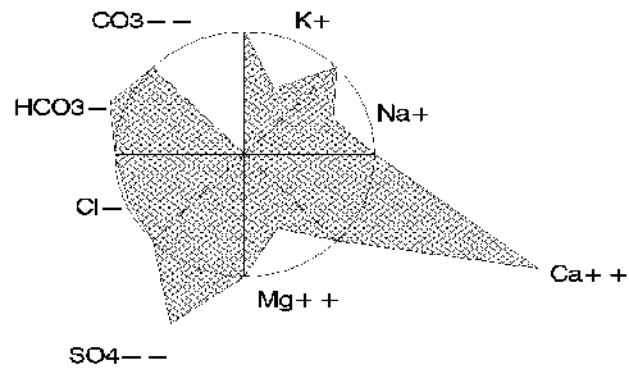

Blanton Lake

Pasco County

USGS Quadrangle: Lacoochee Major Land Use/Land Cover (1990)
 Section/Township/Range: 18-24S-21E within 500 meters of the lakeshore:
 Approx. Lake Center, Lat/Long: 282409/821450 - cropland and pastureland (45%)
 Surface Area: 90 acres - hardwood - conifer mixed (20%)
 Approx. Lake Elevation: 92 feet - low density residential (14%)
 Lake Type: isolated (type 4)
 Major Basin: Withlacoochee River
 Minor Basin: Owensboro Swamp Outlet
 Lake Region: Southern Brooksville Ridge

Total Number of Samples Collected: 2 Most Recent Sample Collected: January 1996

Parameter	Units (Detection Limit)	Average Value	District Percentile	Florida Percentile
Chlorophyll a	ug/l (1)	10.1	64	38
Total Phosphorus	mg/l as P (0.01)	0.009	31	<5
Total Nitrogen	mg/l as N (0.06)	1.29	60	45
Transparency (Secchi depth)	meters	0.85	26	55
Florida Trophic State Index		50	72	35
Specific Conductance	S/cm at 25C (1)	114	17	29
pH	standard units (0.1)	7.0	34	30
Color	PtCo units (1)	113	91	82
Turbidity	NTU (1)	2.3	55	24
Total Alkalinity	mg/l as CaCO3 (1)	16	37	34
Hardness	mg/l as CaCO3 (0.02)	37	30	
Total Suspended Solids	mg/l (0.05)	2.6	60	
Ammonia	mg/l as N (0.03)	0.052	76	
Nitrate+Nitrite	mg/l as N (0.01)	0.005	33	
Total Kjeldahl Nitrogen	mg/l as N (0.06)	1.28	67	
Orthophosphorus	mg/l as P (0.01)	0.005	56	
Chloride	mg/l (0.05)	19	51	
Sulfate	mg/l (0.05)	5	20	
Sodium	mg/l (0.06)	6.4	25	
Potassium	mg/l (0.07)	2.3	37	
Calcium	mg/l (0.04)	7.1	25	
Magnesium	mg/l (0.006)	4.5	63	
Iron	ug/l (0.03)	133	87	

Based upon the average FTSI of 50, water quality is considered good. Blanton Lake can be characterized as a highly colored, soft water, eutrophic lake, with low concentrations of total phosphorus. The chemical type of water (predominant ionic composition) is calcium chloride.

Plots and Trends: No or insufficient data for plotting or trend detection. Shown is a diagram of the relative ionic composition of the lake water.

MAJOR IONS (% meq/l)

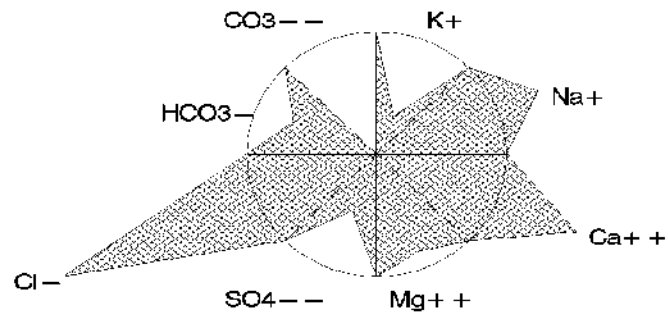

Blanton Lake, Pasco County

Crews Lake Pasco County

USGS Quadrangle:	Port Richey NE	Major Land Use/Land Cover (1990)
Section/Township/Range:	16-24S-18E	within 500 meters of the lakeshore:
Approx. Lake Center, Lat/Long:	282341/823039	- cropland and pastureland (22%)
Surface Area:	693 acres	- hardwood - conifer mixed (18%)
Approx. Lake Elevation:	93 feet	- wet prairies (14%)
Observed Maximum Depth: 6.6 feet (reference elevation 92.94 feet)		
Lake Type: inflow and outflow (type 3)		
Major Basin: Upper Coastal Drainage		
Minor Basin: Crews Lake Outlet		
Lake Region: Weeki Wachee Hills		
Public Access: yes		

Total Number of Samples Collected: 2 Most Recent Sample Collected: February 1997

Parameter	Units (Detection Limit)	Average Value	District Percentile	Florida Percentile
Chlorophyll a	ug/l (1)	4.0	36	16
Total Phosphorus	mg/l as P (0.01)	0.009	31	<5
Total Nitrogen	mg/l as N (0.06)	1.43	68	53
Transparency (Secchi depth)	meters	-	-	-
Florida Trophic State Index		36	45	11
Specific Conductance	S/cm at 25C (1)	96	12	21
pH	standard units (0.1)	7.1	38	35
Color	PtCo units (1)	40	72	30
Turbidity	NTU (1)	0.9	28	<5
Total Alkalinity	mg/l as CaCO3 (1)	30	58	49
Hardness	mg/l as CaCO3 (0.02)	38	32	
Total Suspended Solids	mg/l (0.05)	1.0	28	
Ammonia	mg/l as N (0.03)	0.015	60	
Nitrate+Nitrite	mg/l as N (0.01)	0.005	33	
Total Kjeldahl Nitrogen	mg/l as N (0.06)	1.43	76	
Orthophosphorus	mg/l as P (0.01)	0.005	56	
Chloride	mg/l (0.05)	9	12	
Sulfate	mg/l (0.05)	1	6	
Sodium	mg/l (0.06)	4.8	11	
Potassium	mg/l (0.07)	0.8	16	
Calcium	mg/l (0.04)	13.1	54	
Magnesium	mg/l (0.006)	1.3	12	
Iron	ug/l (0.03)	146	88	

Based upon the average FTSI of 36, water quality is considered good. Crews Lake can be characterized as a colored, soft water, mesotrophic lake. The chemical type of water (predominant ionic composition) is calcium bicarbonate.

Plots and Trends: Lake surface elevation has been depressed through most of the 1990s, compared to lake levels during the period 1964 to late 1980s. Measures of water chemistry have been highly variable (total alkalinity range 10 to 100 mg/l, conductivity range 50 to 270 S/cm, hardness range 20 to 100 mg/l). Also shown is a diagram of the relative ionic composition of the lake water.

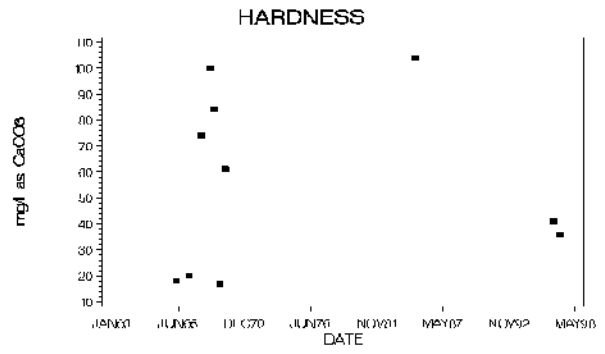
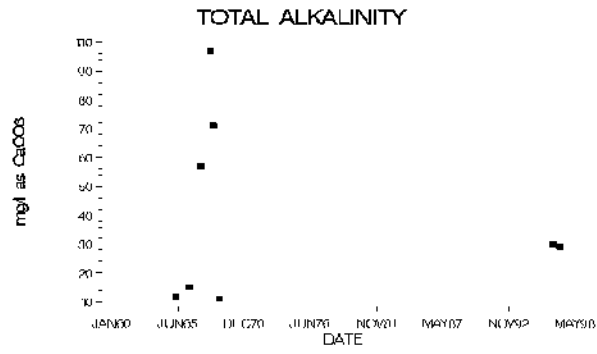
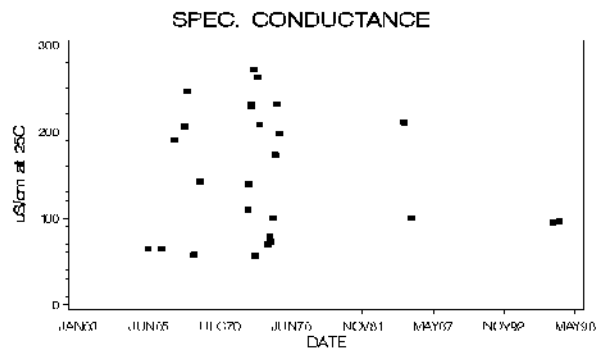
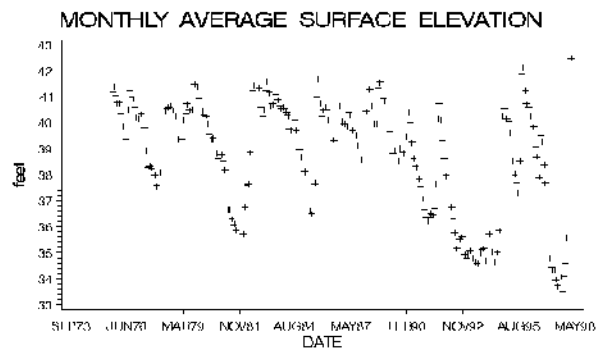

MAJOR IONS (% meq/l)

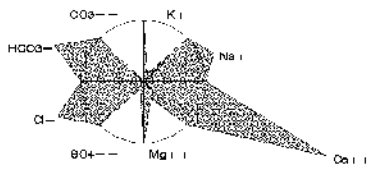

Dowling Lake

Pasco County

USGS Quadrangle: Spring Lake Major Land Use/Land Cover (1990)
 Section/Township/Range: 31-23S-21E within 500 meters of the lakeshore:
 Approx. Lake Center, Lat/Long: 282611/821459 - cropland and pastureland (32%)
 Surface Area: 90 acres - upland coniferous forests (19%)
 Approx. Lake Elevation: 89 feet - hardwood - conifer mixed (17%)
 Lake Type: isolated (type 4)
 Major Basin: Withlacoochee River
 Minor Basin: Withlacoochee River
 Lake Region: Southern Brooksville Ridge

Total Number of Samples Collected: 2 Most Recent Sample Collected: January 1996

Parameter	Units (Detection Limit)	Average Value	District Percentile	Florida Percentile
Chlorophyll a	ug/l (1)	4.1	37	17
Total Phosphorus	mg/l as P (0.01)	0.005	31	<5
Total Nitrogen	mg/l as N (0.06)	1.66	74	68
Transparency (Secchi depth)	meters	1.50	49	76
Florida Trophic State Index		31	29	6
Specific Conductance	S/cm at 25C (1)	95	12	21
pH	standard units (0.1)	7.3	50	45
Color	PtCo units (1)	45	76	35
Turbidity	NTU (1)	1.9	49	19
Total Alkalinity	mg/l as CaCO3 (1)	10	27	25
Hardness	mg/l as CaCO3 (0.02)	26	16	
Total Suspended Solids	mg/l (0.05)	1.4	37	
Ammonia	mg/l as N (0.03)	0.015	60	
Nitrate+Nitrite	mg/l as N (0.01)	0.020	51	
Total Kjeldahl Nitrogen	mg/l as N (0.06)	1.64	81	
Orthophosphorus	mg/l as P (0.01)	0.005	56	
Chloride	mg/l (0.05)	17	41	
Sulfate	mg/l (0.05)	6	23	
Sodium	mg/l (0.06)	7.4	37	
Potassium	mg/l (0.07)	1.0	18	
Calcium	mg/l (0.04)	4.5	11	
Magnesium	mg/l (0.006)	3.6	54	
Iron	ug/l (0.03)	61	69	

Based upon the average FTSI of 31, water quality is considered good. Dowling Lake can be characterized as a colored, soft water, oligo-mesotrophic lake, with low concentrations of total phosphorus. The chemical type of water (predominant ionic composition) is sodium chloride.

Also of note:

- Hydrilla and waterhyacinth were observed.

Plots and Trends: No or insufficient data for plotting or trend detection. Shown is a diagram of the relative ionic composition of the lake water.

MAJOR IONS (% meq/l)

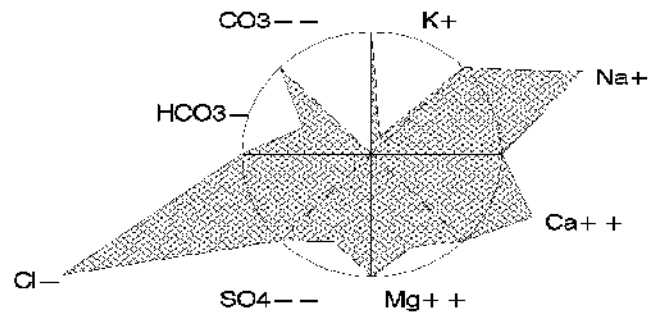

Dowling Lake, Pasco County

East (Cow) Lake

Pasco County

USGS Quadrangle: Lutz Major Land Use/Land Cover (1990)
 Section/Township/Range: 19-26S-19E within 500 meters of the lakeshore:
 Approx. Lake Center, Lat/Long: 281233/822627 - medium density residential (51%)
 Surface Area: 98 acres - tree crops, typically citrus (23%)
 Approx. Lake Elevation: 79 feet - other open lands - rural (13%)
 Lake Type: outflow (type 2)
 Major Basin: Hillsborough River
 Minor Basin: Lake Hanna Outlet
 Lake Region: Land-o-Lakes

Total Number of Samples Collected: 2 Most Recent Sample Collected: January 1995

Parameter	Units (Detection Limit)	Average Value	District Percentile	Florida Percentile
Chlorophyll a	ug/l (1)	8.4	59	34
Total Phosphorus	mg/l as P (0.01)	0.019	63	10
Total Nitrogen	mg/l as N (0.06)	0.99	40	33
Transparency (Secchi depth)	meters	2.00	64	85
Florida Trophic State Index		44	61	23
Specific Conductance	S/cm at 25C (1)	309	89	70
pH	standard units (0.1)	7.3	50	45
Color	PtCo units (1)	5	9	5
Turbidity	NTU (1)	2.4	56	25
Total Alkalinity	mg/l as CaCO3 (1)	31	60	50
Hardness	mg/l as CaCO3 (0.02)	55	56	
Total Suspended Solids	mg/l (0.05)	3.5	67	
Ammonia	mg/l as N (0.03)	0.015	60	
Nitrate+Nitrite	mg/l as N (0.01)	0.009	33	
Total Kjeldahl Nitrogen	mg/l as N (0.06)	0.99	47	
Orthophosphorus	mg/l as P (0.01)	0.005	56	
Chloride	mg/l (0.05)	59	>95	
Sulfate	mg/l (0.05)	24	69	
Sodium	mg/l (0.06)	33.5	>95	
Potassium	mg/l (0.07)	4.7	64	
Calcium	mg/l (0.04)	14.0	56	
Magnesium	mg/l (0.006)	4.9	68	
Iron	ug/l (0.03)	18	15	

Based upon the average FTSI of 44, water quality is considered good. East (Cow) Lake can be characterized as a clear (color<=10 color units), soft water, eutrophic lake. The chemical type of water (predominant ionic composition) is sodium chloride.

Plots and Trends: The plot of lake surface elevation demonstrates that lake level in East Lake has been stable over the period of record. The range in fluctuation was approximately 3 feet over the period of record. Also shown is a diagram of the relative ionic composition of the lake water.

MONTHLY AVERAGE SURFACE ELEVATION

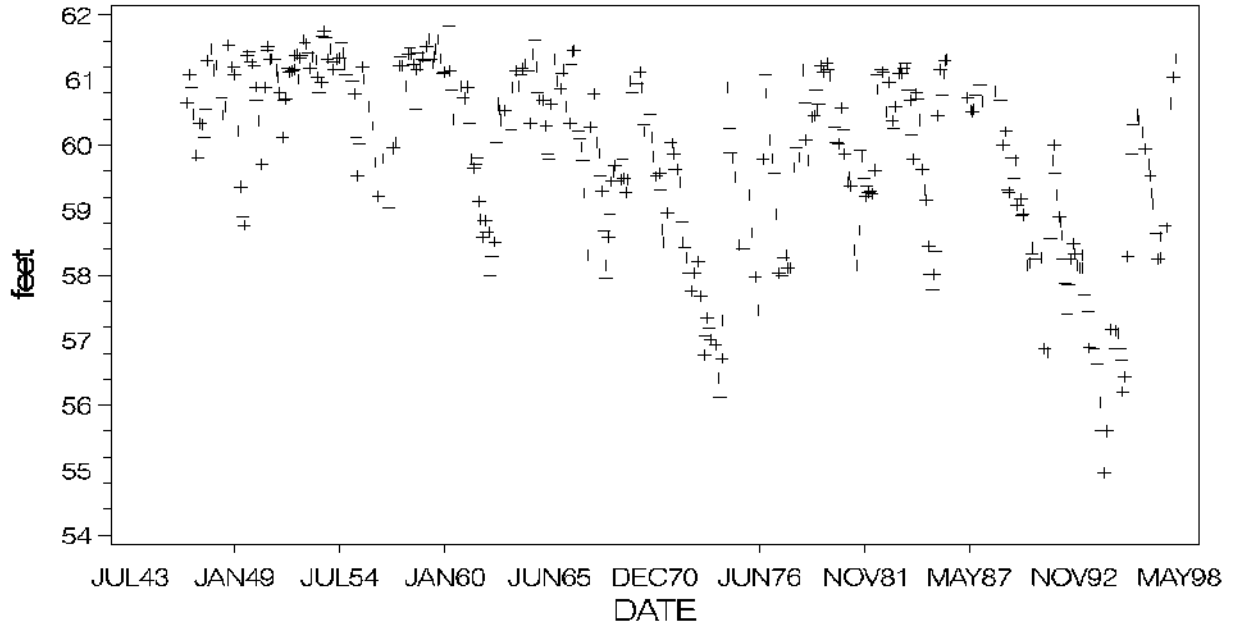

MAJOR IONS (% meq/l)

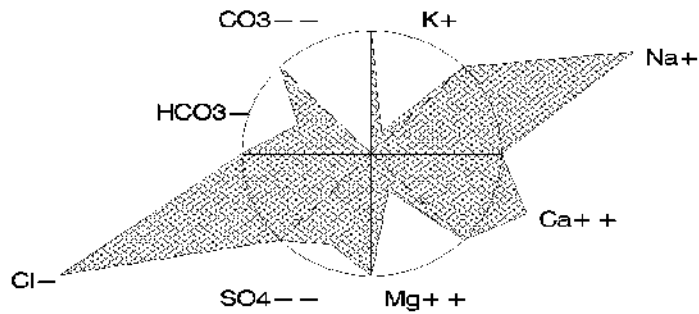

East (Cow) Lake, Pasco County

Fishing Lake Pasco County

USGS Quadrangle: Odessa Major Land Use/Land Cover (1990)
 Section/Township/Range: 34-26S-17E within 500 meters of the lakeshore:
 Approx. Lake Center, Lat/Long: 281057/823519 - open land (27%)
 Surface Area: 13 acres - medium density residential (21%)
 Approx. Lake Elevation: 49 feet - shrub and brushland range (13%)
 Lake Type: outflow (type 2)
 Major Basin: Upper Coastal Drainage
 Minor Basin: Lake Ann Outlet
 Lake Region: Keystone Lakes

Total Number of Samples Collected: 2 Most Recent Sample Collected: January 1995

Parameter	Units (Detection Limit)	Average Value	District Percentile	Florida Percentile
Chlorophyll a	ug/l (1)	11.8	70	41
Total Phosphorus	mg/l as P (0.01)	0.019	63	10
Total Nitrogen	mg/l as N (0.06)	0.74	21	22
Transparency (Secchi depth)	meters	1.65	54	79
Florida Trophic State Index		47	69	29
Specific Conductance	S/cm at 25C (1)	154	40	43
pH	standard units (0.1)	7.4	57	50
Color	PtCo units (1)	25	62	20
Turbidity	NTU (1)	2.4	56	25
Total Alkalinity	mg/l as CaCO3 (1)	14	33	32
Hardness	mg/l as CaCO3 (0.02)	31	23	
Total Suspended Solids	mg/l (0.05)	2.0	51	
Ammonia	mg/l as N (0.03)	0.015	60	
Nitrate+Nitrite	mg/l as N (0.01)	0.010	34	
Total Kjeldahl Nitrogen	mg/l as N (0.06)	0.73	27	
Orthophosphorus	mg/l as P (0.01)	0.005	56	
Chloride	mg/l (0.05)	30	85	
Sulfate	mg/l (0.05)	8	31	
Sodium	mg/l (0.06)	16.5	87	
Potassium	mg/l (0.07)	2.1	35	
Calcium	mg/l (0.04)	7.6	27	
Magnesium	mg/l (0.006)	2.9	43	
Iron	ug/l (0.03)	23	28	

Based upon the average FTSI of 47, water quality is considered good. Fishing Lake can be characterized as a moderately colored, soft water, meso-eutrophic lake, with low concentrations of total nitrogen. The chemical type of water (predominant ionic composition) is sodium chloride.

Plots and Trends: Lake surface elevation shows a decline in lake levels over the short period of record. Fishing Lake is connected by a canal to Lake Parker (Ann), which has a longer period of record for lake elevation. Lake Parker shows a similar decline over the same period, but no long-term trend for the period of record extending from 1969 through the present. Also shown is a diagram of the relative ionic composition of the lake water.

MONTHLY AVERAGE SURFACE ELEVATION

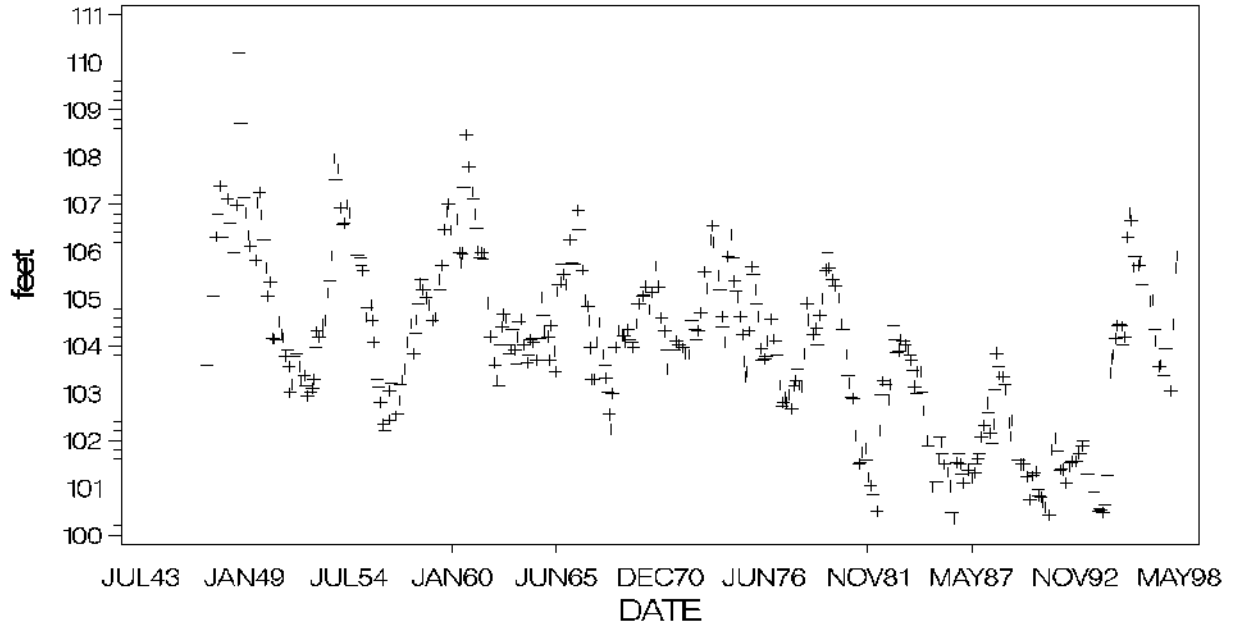

MAJOR IONS (% meq/l)

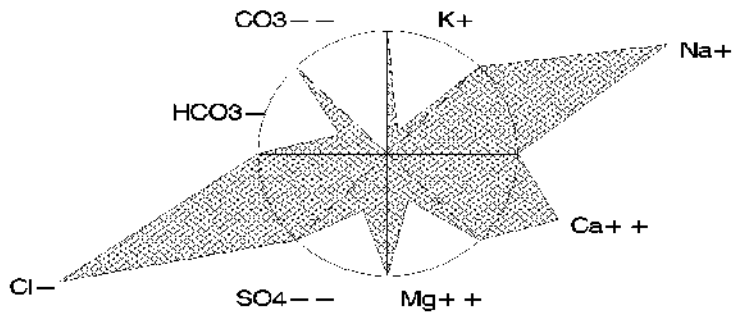

Fishing Lake, Pasco County

Floyd Lake

Pasco County

USGS Quadrangle: Lutz Major Land Use/Land Cover (1990)
 Section/Township/Range: 36-26S-18E within 500 meters of the lakeshore:
 Approx. Lake Center, Lat/Long: 281107/822753 - commercial and services (25%)
 Surface Area: 53 acres - high density residential (19%)
 Approx. Lake Elevation: 69 feet - open land (9%)
 Average Depth: 3.3 feet
 (reference elevation 66 feet)
 Lake Type: inflow and outflow (type 3)
 Major Basin: Hillsborough River
 Minor Basin: Lake Hanna Outlet
 Lake Region: Land-o-Lakes

Total Number of Samples Collected: 2 Most Recent Sample Collected: January 1995

Parameter	Units (Detection Limit)	Average Value	District Percentile	Florida Percentile
Chlorophyll a	ug/l (1)	2.3	15	10
Total Phosphorus	mg/l as P (0.01)	0.011	38	6
Total Nitrogen	mg/l as N (0.06)	1.04	43	35
Transparency (Secchi depth)	meters	1.00	35	63
Florida Trophic State Index		35	42	9
Specific Conductance	S/cm at 25C (1)	180	50	48
pH	standard units (0.1)	7.3	50	45
Color	PtCo units (1)	18	51	15
Turbidity	NTU (1)	0.9	28	<5
Total Alkalinity	mg/l as CaCO3 (1)	32	62	51
Hardness	mg/l as CaCO3 (0.02)	55	56	
Total Suspended Solids	mg/l (0.05)	1.0	28	
Ammonia	mg/l as N (0.03)	0.034	65	
Nitrate+Nitrite	mg/l as N (0.01)	0.005	33	
Total Kjeldahl Nitrogen	mg/l as N (0.06)	1.04	51	
Orthophosphorus	mg/l as P (0.01)	0.005	56	
Chloride	mg/l (0.05)	18	46	
Sulfate	mg/l (0.05)	20	61	
Sodium	mg/l (0.06)	12.0	69	
Potassium	mg/l (0.07)	3.0	46	
Calcium	mg/l (0.04)	17.5	67	
Magnesium	mg/l (0.006)	2.6	38	
Iron	ug/l (0.03)	39	52	

Based upon the average FTSI of 35, water quality is considered good. Floyd Lake can be characterized as a clear to moderately colored (10<color<20 color units), soft water, oligotrophic lake. The chemical type of water (predominant ionic composition) is calcium chloride (2 samples) or calcium sulfate (1 sample).

Plots and Trends: No or insufficient data available for plotting or trend detection. Shown is a diagram of the relative ionic composition of the lake water.

MAJOR IONS (% meq/l)

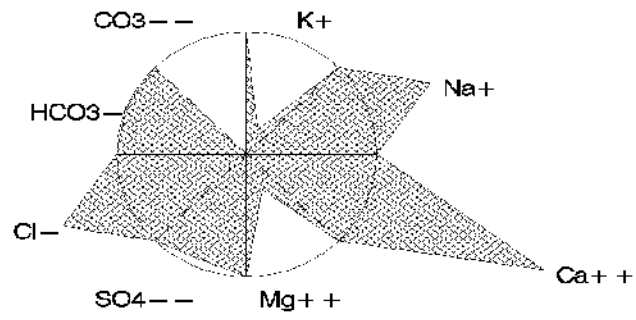

Gooseneck Lake

Pasco County

USGS Quadrangle: Lutz Major Land Use/Land Cover (1990)
 Section/Township/Range: 29-26S-19E within 500 meters of the lakeshore:
 Approx. Lake Center, Lat/Long: 281143/822546 - cropland and pastureland (30%)
 Surface Area: 27 acres - low density residential (22%)
 Approx. Lake Elevation: 74 feet - tree crops, typically citrus (16%)
 Average Depth: 6.1 feet
 Observed Maximum Depth: 13 feet
 (reference elevation 72.1 feet)
 Lake Type: outflow (type 2)
 Major Basin: Hillsborough River
 Minor Basin: Cypress Creek
 Lake Region: Land-o-Lakes

Total Number of Samples Collected: 2 Most Recent Sample Collected: February 1997

Parameter	Units (Detection Limit)	Average Value	District Percentile	Florida Percentile
Chlorophyll a	ug/l (1)	1.8	10	7
Total Phosphorus	mg/l as P (0.01)	0.005	31	<5
Total Nitrogen	mg/l as N (0.06)	0.54	6	12
Transparency (Secchi depth)	meters		-	-
Florida Trophic State Index		25	14	<5
Specific Conductance	S/cm at 25C (1)	119	19	31
pH	standard units (0.1)	7.3	50	45
Color	PtCo units (1)	23	58	19
Turbidity	NTU (1)	0.5	28	<5
Total Alkalinity	mg/l as CaCO3 (1)	28	55	47
Hardness	mg/l as CaCO3 (0.02)	38	32	
Total Suspended Solids	mg/l (0.05)	0.4	8	
Ammonia	mg/l as N (0.03)	0.015	60	
Nitrate+Nitrite	mg/l as N (0.01)	0.005	33	
Total Kjeldahl Nitrogen	mg/l as N (0.06)	0.54	10	
Orthophosphorus	mg/l as P (0.01)	0.005	56	
Chloride	mg/l (0.05)	11	19	
Sulfate	mg/l (0.05)	7	27	
Sodium	mg/l (0.06)	6.7	30	
Potassium	mg/l (0.07)	3.7	51	
Calcium	mg/l (0.04)	11.4	45	
Magnesium	mg/l (0.006)	2.2	31	
Iron	ug/l (0.03)	52	62	

Based upon the average FTSI of 25, water quality is considered good. Gooseneck Lake can be characterized as a moderately colored, soft water, oligotrophic lake, with low concentrations of total phosphorus, very low concentrations of total nitrogen. The chemical type of water (predominant ionic composition) is calcium chloride.

Also of note:

- Cattails dominate more than 30% of the lake shoreline.

Plots and Trends: No or insufficient data available for plotting or trend detection. Shown is a diagram of the relative ionic composition of the lake water.

MAJOR IONS (% meq/l)

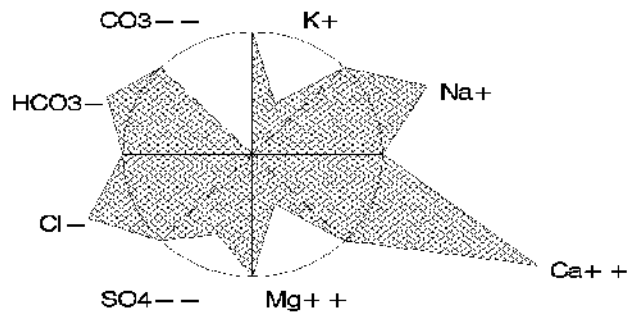

Gooseneck Lake, Pasco County

Green Lake Pasco County

USGS Quadrangle:	Fivay Junction	Major Land Use/Land Cover (1990)
Section/Township/Range:	16-25S-18E	within 500 meters of the lakeshore:
Approx. Lake Center, Lat/Long:	281857/823011	- pine flatwoods (31%)
Surface Area:	26 acres	- cropland and pastureland (28%)
Approx. Lake Elevation:	74 feet	- medium density residential (12%)
Average Depth: 6.4 feet		
Observed Maximum Depth: 10 feet		
(reference elevation not given)		
Lake Type: isolated (type 4)		
Major Basin: Upper Coastal Drainage		
Minor Basin: Gowers Corner Slough		
Lake Region: Weeki Wachee Hills		

Total Number of Samples Collected: 2 Most Recent Sample Collected: January 1995

Parameter	Units (Detection Limit)	Average Value	District Percentile	Florida Percentile
Chlorophyll a	ug/l (1)	5.8	48	24
Total Phosphorus	mg/l as P (0.01)	0.019	63	10
Total Nitrogen	mg/l as N (0.06)	1.85	81	78
Transparency (Secchi depth)	meters	1.45	48	75
Florida Trophic State Index		45	62	25
Specific Conductance	S/cm at 25C (1)	103	13	24
pH	standard units (0.1)	6.7	21	23
Color	PtCo units (1)	18	51	15
Turbidity	NTU (1)	3.3	65	35
Total Alkalinity	mg/l as CaCO3 (1)	7	18	20
Hardness	mg/l as CaCO3 (0.02)	18	8	
Total Suspended Solids	mg/l (0.05)	4.4	75	
Ammonia	mg/l as N (0.03)	0.029	60	
Nitrate+Nitrite	mg/l as N (0.01)	0.022	54	
Total Kjeldahl Nitrogen	mg/l as N (0.06)	1.82	86	
Orthophosphorus	mg/l as P (0.01)	0.008	56	
Chloride	mg/l (0.05)	19	51	
Sulfate	mg/l (0.05)	7	27	
Sodium	mg/l (0.06)	11.0	64	
Potassium	mg/l (0.07)	1.1	20	
Calcium	mg/l (0.04)	5.2	15	
Magnesium	mg/l (0.006)	1.2	10	
Iron	ug/l (0.03)	31	40	

Based upon the average FTSI of 45, water quality is considered good. Green Lake can be characterized as a clear to moderately colored (10<color<20 color units), soft water, meso-eutrophic lake, with high concentrations of total nitrogen. The chemical type of water (predominant ionic composition) is sodium chloride.

Plots and Trends: No or insufficient data available for plotting or trend detection. Shown is a diagram of the relative ionic composition of the lake water.

MAJOR IONS (% meq/l)

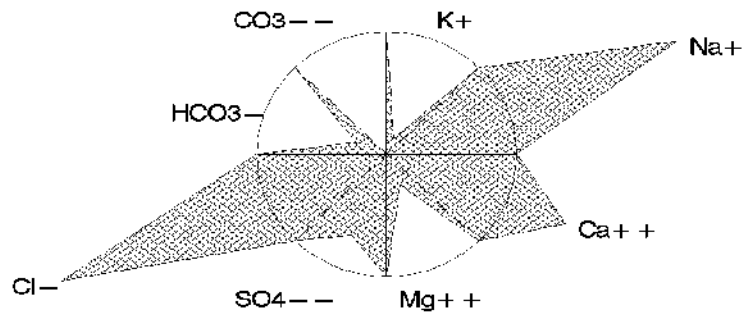

Green Lake, Pasco County

Lake Hancock

Pasco County

USGS Quadrangle: Spring Lake Major Land Use/Land Cover (1990)
 Section/Township/Range: 5-24S-20E within 500 meters of the lakeshore:
 Approx. Lake Center, Lat/Long: 282556/821957 - stream and lake swamps (24%)
 Surface Area: 519 acres - hardwood - conifer mixed (23%)
 Approx. Lake Elevation: 107 feet - other open lands - rural (14%)
 Lake Type: inflow (type 1)
 Major Basin: Upper Coastal Drainage
 Minor Basin: Crews Lake Outlet
 Lake Region: Southern Brooksville Ridge

Total Number of Samples Collected: 15 Most Recent Sample Collected: September 1995

Parameter	Units (Detection Limit)	Average Value	District Percentile	Florida Percentile
Chlorophyll a	ug/l (1)	7.5	55	32
Total Phosphorus	mg/l as P (0.01)	0.020	65	10
Total Nitrogen	mg/l as N (0.06)	0.84	28	27
Transparency (Secchi depth)	meters	0.85	26	55
Florida Trophic State Index		37	46	12
Specific Conductance	S/cm at 25C (1)	123	21	32
pH	standard units (0.1)	8.8	95	90
Color	PtCo units (1)	18	51	15
Turbidity	NTU (1)	2.4	56	25
Total Alkalinity	mg/l as CaCO3 (1)	20	42	39
Hardness	mg/l as CaCO3 (0.02)	41	38	
Total Suspended Solids	mg/l (0.05)	2.3	56	
Ammonia	mg/l as N (0.03)	0.030	61	
Nitrate+Nitrite	mg/l as N (0.01)	0.006	33	
Total Kjeldahl Nitrogen	mg/l as N (0.06)	0.83	34	
Orthophosphorus	mg/l as P (0.01)	0.006	56	
Chloride	mg/l (0.05)	18	46	
Sulfate	mg/l (0.05)	2	10	
Sodium	mg/l (0.06)	7.6	40	
Potassium	mg/l (0.07)	1.4	24	
Calcium	mg/l (0.04)	9.7	38	
Magnesium	mg/l (0.006)	4.0	58	
Iron	ug/l (0.03)	43	56	

Based upon the average FTSI of 37, water quality is considered good. Lake Hancock can be characterized as a clear to moderately colored (10<color<20 color units), soft water, oligo-mesotrophic lake. The chemical type of water (predominant ionic composition) is calcium chloride.

Also of note:

- The measured pH was high.
- Hydrilla was observed in the lake.

Plots and Trends: No trends are evident in the lake surface elevation period of record for Lake Hancock. Lake levels were low for much of the 1990s, but have since recovered. Also shown is a diagram of the relative ionic composition of the lake water.

MONTHLY AVERAGE SURFACE ELEVATION

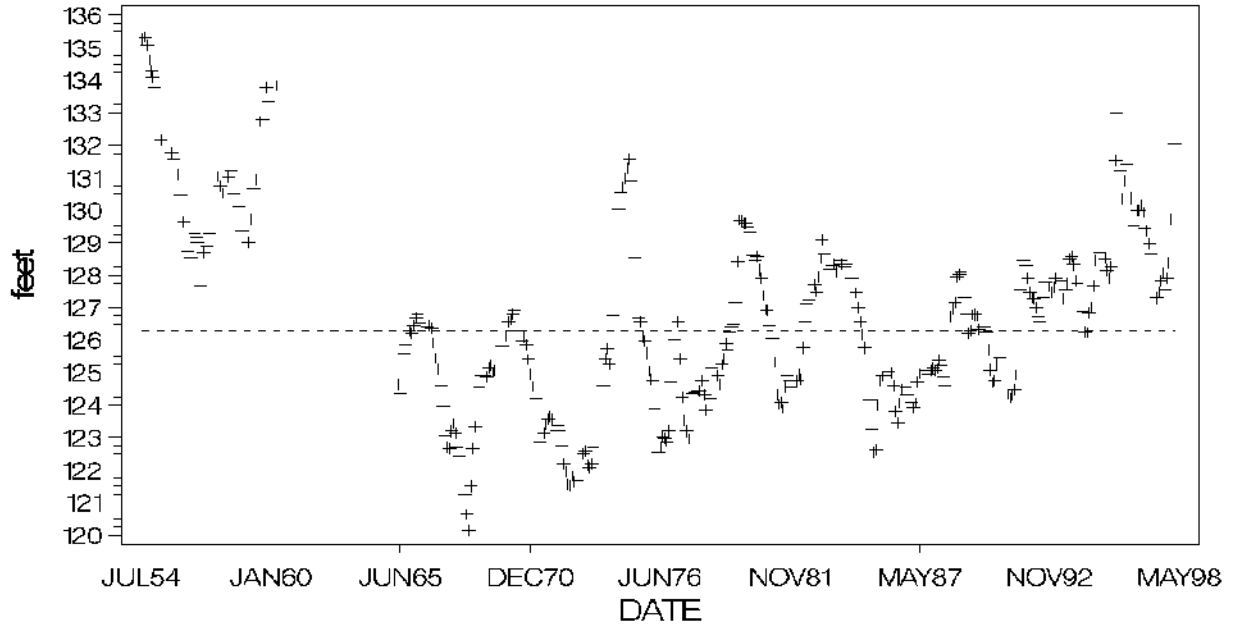

MAJOR IONS (% meq/l)

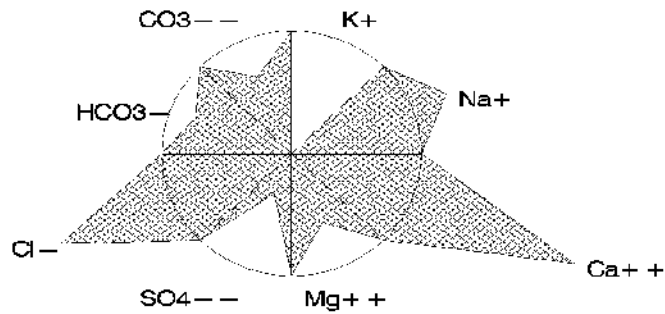

Hunters Lake Pasco County

USGS Quadrangle: Fivay Junction Major Land Use/Land Cover (1990)
 Section/Township/Range: 4-25S-17E within 500 meters of the lakeshore:
 Approx. Lake Center, Lat/Long: 281958/823628 - stream and lake swamps (26%)
 Surface Area: 5 acres - medium density residential (20%)
 Approx. Lake Elevation: 33 feet - pine flatwoods (19%)
 Lake Type: outflow (type 2)
 Major Basin: Upper Coastal Drainage
 Minor Basin: Bear Creek
 Lake Region: Tampa Plain

Total Number of Samples Collected: 2 Most Recent Sample Collected: January 1995

Parameter	Units (Detection Limit)	Average Value	District Percentile	Florida Percentile
Chlorophyll a	ug/l (1)	3.6	32	15
Total Phosphorus	mg/l as P (0.01)	0.029	76	19
Total Nitrogen	mg/l as N (0.06)	2.20	88	84
Transparency (Secchi depth)	meters	1.10	38	67
Florida Trophic State Index		44	61	23
Specific Conductance	S/cm at 25C (1)	232	72	57
pH	standard units (0.1)	7.5	61	53
Color	PtCo units (1)	110	91	81
Turbidity	NTU (1)	3.0	63	32
Total Alkalinity	mg/l as CaCO3 (1)	82	95	78
Hardness	mg/l as CaCO3 (0.02)	103	91	
Total Suspended Solids	mg/l (0.05)	1.4	37	
Ammonia	mg/l as N (0.03)	0.282	>95	
Nitrate+Nitrite	mg/l as N (0.01)	0.036	62	
Total Kjeldahl Nitrogen	mg/l as N (0.06)	2.16	93	
Orthophosphorus	mg/l as P (0.01)	0.024	87	
Chloride	mg/l (0.05)	14	30	
Sulfate	mg/l (0.05)	5	20	
Sodium	mg/l (0.06)	7.6	40	
Potassium	mg/l (0.07)	0.3	7	
Calcium	mg/l (0.04)	38.5	>95	
Magnesium	mg/l (0.006)	1.7	20	
Iron	ug/l (0.03)	774	>95	

Based upon the average FTSI of 44, water quality is considered good. Hunters Lake can be characterized as a highly colored, medium hard water, oligo-mesotrophic lake, with high concentrations of total nitrogen. The chemical type of water (predominant ionic composition) is calcium bicarbonate.

Plots and Trends: No or insufficient data available for plotting or trend detection. Shown is a diagram of the relative ionic composition of the lake water.

MAJOR IONS (% meq/l)

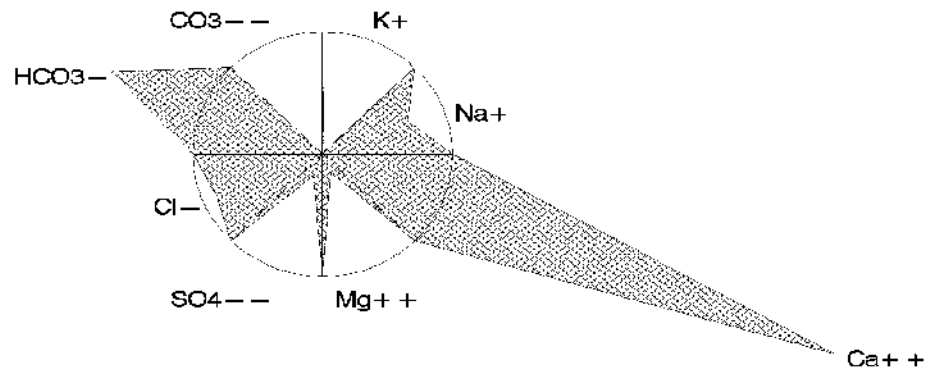

Hunters Lake, Pasco County

Lake Iola

Pasco County

USGS Quadrangle: Spring Lake Major Land Use/Land Cover (1990)
 Section/Township/Range: 15-24S-20E within 500 meters of the lakeshore:
 Approx. Lake Center, Lat/Long: 282338/821753 - upland coniferous forests (44%)
 Surface Area: 107 acres - medium density residential (11%)
 Approx. Lake Elevation: 148 feet - other open lands - rural (10%)
 Average Depth: 24.7 feet
 Observed Maximum Depth: 45 feet
 (reference elevation 146.2 feet)
 Lake Type: outflow (type 2)
 Major Basin: Upper Coastal Drainage
 Minor Basin: Crews Lake Outlet
 Lake Region: Southern Brooksville Ridge
 Public Access: yes

Total Number of Samples Collected: 2 Most Recent Sample Collected: January 1995

Parameter	Units (Detection Limit)	Average Value	District Percentile	Florida Percentile
Chlorophyll a	ug/l (1)	2.2	14	9
Total Phosphorus	mg/l as P (0.01)	0.005	31	<5
Total Nitrogen	mg/l as N (0.06)	0.92	34	31
Transparency (Secchi depth)	meters	3.55	90	>95
Florida Trophic State Index		22	9	<5
Specific Conductance	S/cm at 25C (1)	149	38	42
pH	standard units (0.1)	7.3	50	45
Color	PtCo units (1)	5	9	5
Turbidity	NTU (1)	1.1	32	7
Total Alkalinity	mg/l as CaCO3 (1)	8	21	22
Hardness	mg/l as CaCO3 (0.02)	39	34	
Total Suspended Solids	mg/l (0.05)	1.0	28	
Ammonia	mg/l as N (0.03)	0.015	60	
Nitrate+Nitrite	mg/l as N (0.01)	0.102	82	
Total Kjeldahl Nitrogen	mg/l as N (0.06)	0.82	33	
Orthophosphorus	mg/l as P (0.01)	0.005	56	
Chloride	mg/l (0.05)	23	69	
Sulfate	mg/l (0.05)	16	52	
Sodium	mg/l (0.06)	9.6	56	
Potassium	mg/l (0.07)	3.9	54	
Calcium	mg/l (0.04)	5.2	15	
Magnesium	mg/l (0.006)	6.2	77	
Iron	ug/l (0.03)	16	11	

Based upon the average FTSI of 22, water quality is considered good. Lake Iola can be characterized as a clear (color<=10 color units), soft water, oligotrophic lake, with low concentrations of total phosphorus. The chemical type of water (predominant ionic composition) is sodium chloride.

Plots and Trends: Lake surface elevations have been highly variable over the period of record. The total range in lake level fluctuation was approximately 12 feet. Though it appears that recent concentrations of total alkalinity and hardness are different from those made in the mid- to late 1960s, the data are too sparse to conclude there are trends. In both cases, the y-axis scales represent a narrow range, and values of total alkalinity (8th percentile) and hardness (39th percentile) for all samples are low to moderate. Specific conductivity has remained fairly constant. Also shown is a diagram of the relative ionic composition of the lake water.

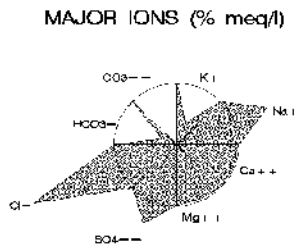
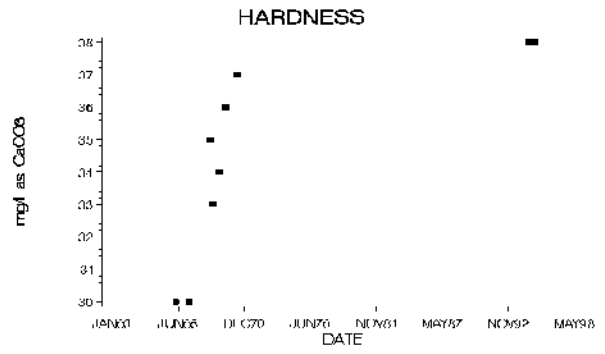
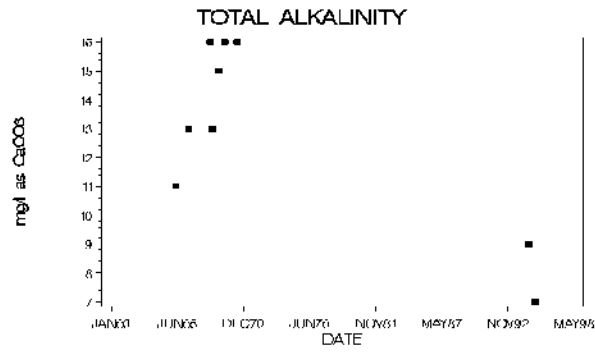
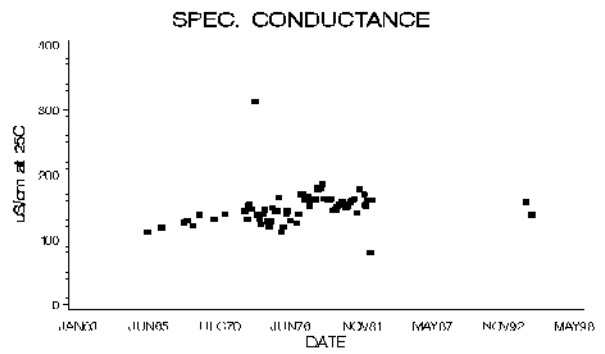
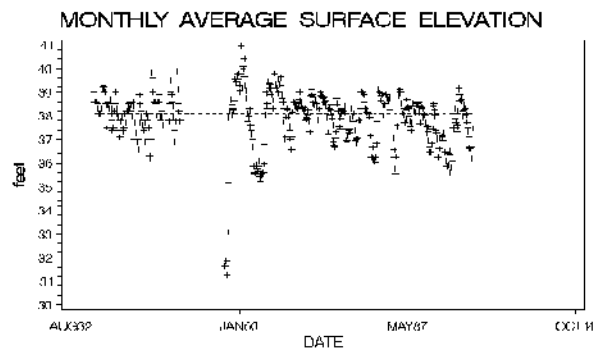

Lake Iola, Pasco County

Jessamine Lake

Pasco County

USGS Quadrangle: Spring Lake Major Land Use/Land Cover (1990)
 Section/Township/Range: 11-24S-20E within 500 meters of the lakeshore:
 Approx. Lake Center, Lat/Long: 282507/821621 - other open lands - rural (67%)
 Surface Area: 77 acres - hardwood - conifer mixed (19%)
 Approx. Lake Elevation: 142 feet - cropland and pastureland (4%)
 Average Depth: 13.2 feet
 Observed Maximum Depth: 21 feet
 (reference elevation 130 feet)
 Lake Type: isolated (type 4)
 Major Basin: Upper Coastal Drainage
 Minor Basin: Crews Lake Outlet
 Lake Region: Southern Brooksville Ridge

Total Number of Samples Collected: 2 Most Recent Sample Collected: February 1997

Parameter	Units (Detection Limit)	Average Value	District Percentile	Florida Percentile
Chlorophyll a	ug/l (1)	38.3	90	73
Total Phosphorus	mg/l as P (0.01)	0.013	46	7
Total Nitrogen	mg/l as N (0.06)	2.36	91	86
Transparency (Secchi depth)	meters	0.99	34	63
Florida Trophic State Index		65	91	67
Specific Conductance	S/cm at 25C (1)	121	20	32
pH	standard units (0.1)	8.1	83	73
Color	PtCo units (1)	30	67	23
Turbidity	NTU (1)	16.9	95	79
Total Alkalinity	mg/l as CaCO3 (1)	27	54	46
Hardness	mg/l as CaCO3 (0.02)	41	38	
Total Suspended Solids	mg/l (0.05)	12.9	94	
Ammonia	mg/l as N (0.03)	0.156	94	
Nitrate+Nitrite	mg/l as N (0.01)	0.218	87	
Total Kjeldahl Nitrogen	mg/l as N (0.06)	2.15	93	
Orthophosphorus	mg/l as P (0.01)	0.005	56	
Chloride	mg/l (0.05)	15	34	
Sulfate	mg/l (0.05)	5	20	
Sodium	mg/l (0.06)	5.6	18	
Potassium	mg/l (0.07)	3.1	47	
Calcium	mg/l (0.04)	4.6	12	
Magnesium	mg/l (0.006)	7.3	81	
Iron	ug/l (0.03)	59	68	

Based upon the average FTSI of 65, water quality is considered fair. Jessamine Lake can be characterized as a moderately colored, soft water, eutrophic to hypereutrophic lake, with high concentrations of total nitrogen. The chemical type of water (predominant ionic composition) is magnesium chloride.

Also of note:

- The measured pH was high.

Plots and Trends: The record of lake surface elevation shows a very wide range of fluctuation. The total range in fluctuation for the period of record is approximately 19 feet. Also shown is a diagram of the relative ionic composition of the lake water.

MONTHLY AVERAGE SURFACE ELEVATION

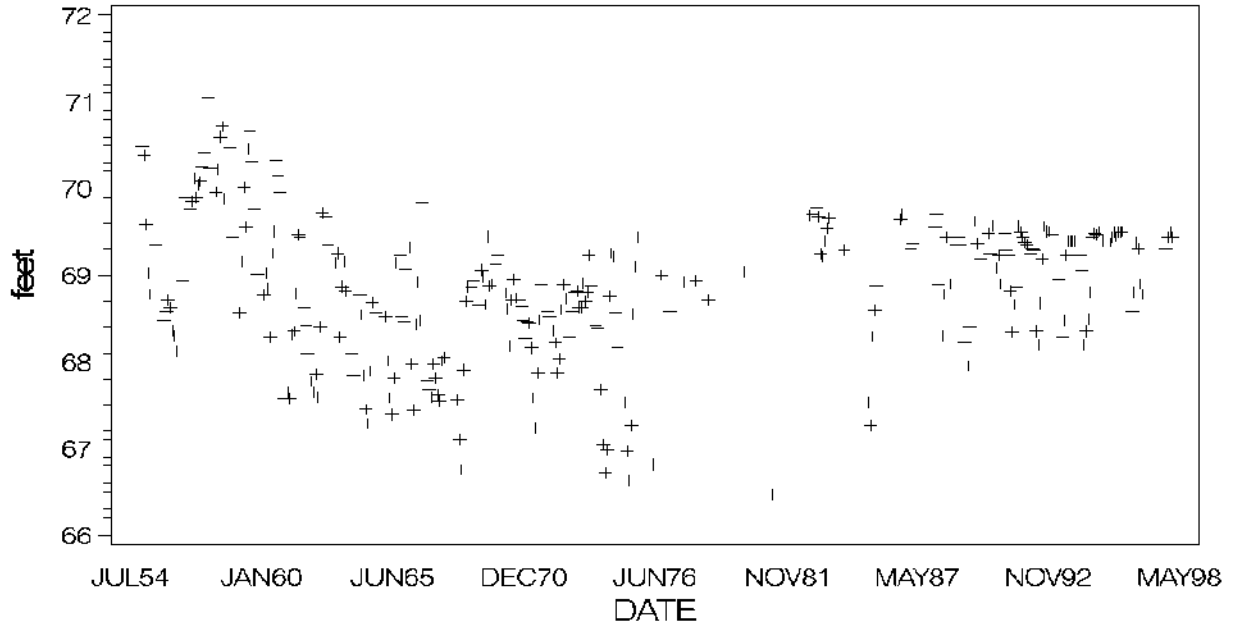

MAJOR IONS (% meq/l)

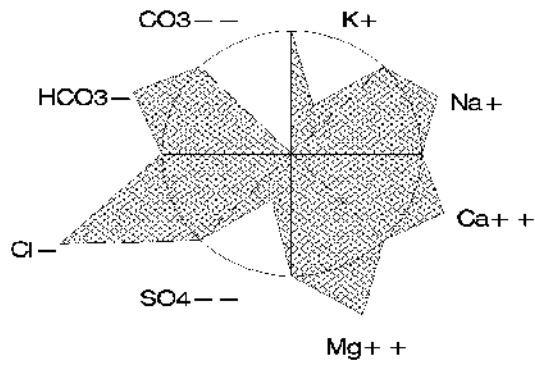

King Lake

Pasco County

USGS Quadrangle: Lutz Major Land Use/Land Cover (1990)
 Section/Township/Range: 7-26S-19E within 500 meters of the lakeshore:
 Approx. Lake Center, Lat/Long: 281349/822707 - medium density residential (31%)
 Surface Area: 122 acres - cypress (14%)
 Approx. Lake Elevation: 74 feet - tree crops, typically citrus (14%)
 Lake Type: outflow (type 2)
 Major Basin: Hillsborough River
 Minor Basin: Lake Hanna Outlet
 Lake Region: Land-o-Lakes

Total Number of Samples Collected: 2 Most Recent Sample Collected: February 1997

Parameter	Units (Detection Limit)	Average Value	District Percentile	Florida Percentile
Chlorophyll a	ug/l (1)	4.1	37	17
Total Phosphorus	mg/l as P (0.01)	0.005	31	<5
Total Nitrogen	mg/l as N (0.06)	0.77	25	24
Transparency (Secchi depth)	meters	3.03	86	>95
Florida Trophic State Index		26	18	<5
Specific Conductance	S/cm at 25C (1)	158	41	43
pH	standard units (0.1)	8.0	81	70
Color	PtCo units (1)	20	55	17
Turbidity	NTU (1)	0.8	28	<5
Total Alkalinity	mg/l as CaCO3 (1)	30	58	49
Hardness	mg/l as CaCO3 (0.02)	43	41	
Total Suspended Solids	mg/l (0.05)	1.1	31	
Ammonia	mg/l as N (0.03)	0.024	60	
Nitrate+Nitrite	mg/l as N (0.01)	0.005	33	
Total Kjeldahl Nitrogen	mg/l as N (0.06)	0.77	31	
Orthophosphorus	mg/l as P (0.01)	0.005	56	
Chloride	mg/l (0.05)	20	56	
Sulfate	mg/l (0.05)	7	27	
Sodium	mg/l (0.06)	10.7	63	
Potassium	mg/l (0.07)	4.9	65	
Calcium	mg/l (0.04)	11.8	46	
Magnesium	mg/l (0.006)	3.3	49	
Iron	ug/l (0.03)	40	53	

Based upon the average FTSI of 26, water quality is considered good. King Lake can be characterized as a moderately colored, soft water, mesotrophic lake, with low concentrations of total phosphorus. The chemical type of water (predominant ionic composition) is calcium chloride.

Also of note:

- The measured pH was high.
- Cattails dominate more than 30% of the lake shoreline.

Plots and Trends: The plot of King Lake surface elevations reveal no long-term trends for the period of record. Also shown is a diagram of the relative ionic composition of the lake water.

MONTHLY AVERAGE SURFACE ELEVATION

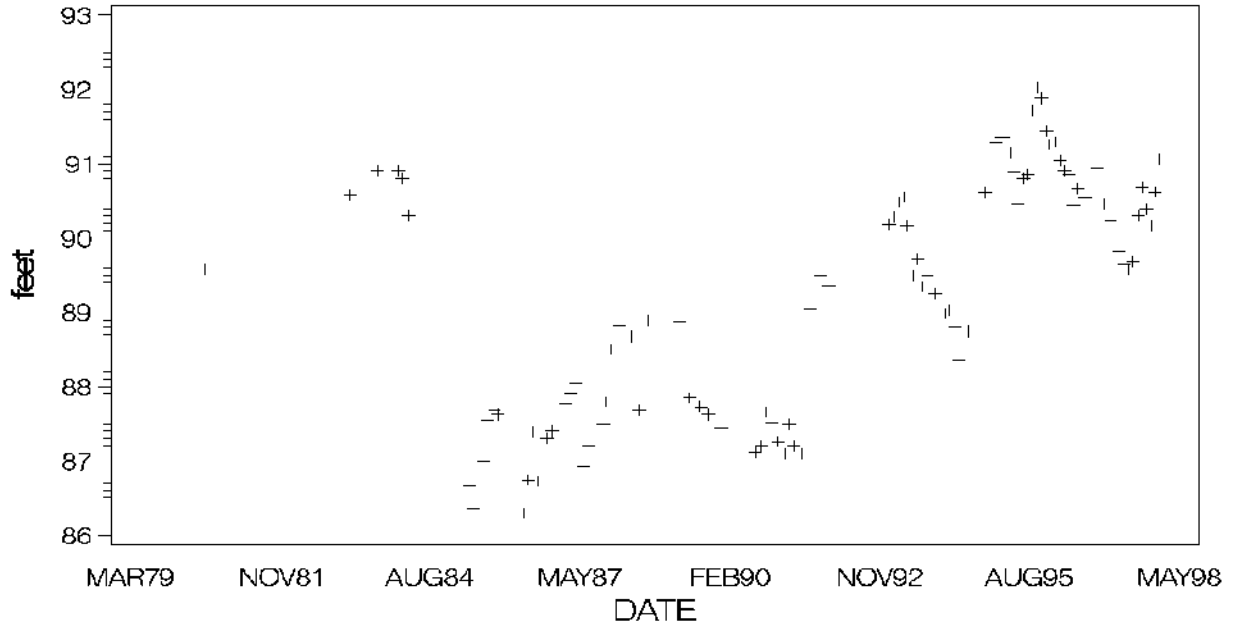

MAJOR IONS (% meq/l)

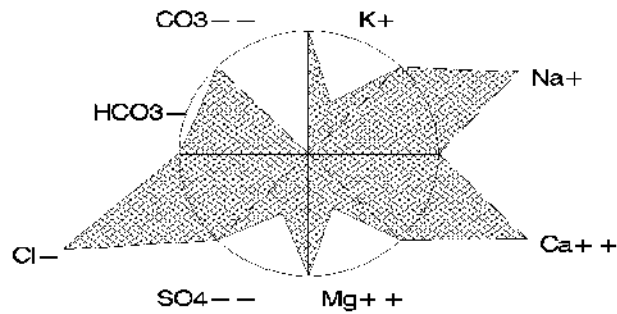

King (East) Lake

Pasco County

USGS Quadrangle: San Antonio Major Land Use/Land Cover (1990)
 Section/Township/Range: 22-25S-20E within 500 meters of the lakeshore:
 Approx. Lake Center, Lat/Long: 281727/821736 - cropland and pastureland (33%)
 Surface Area: 263 acres - freshwater marshes (27%)
 Approx. Lake Elevation: 105 feet - other open lands - rural (12%)
 Average Depth: 4.9 feet
 Observed Maximum Depth: 10 feet
 (reference elevation 103.7 feet)
 Lake Type: outflow (type 2)
 Major Basin: Hillsborough River
 Minor Basin: Bayou Branch
 Lake Region: Southern Brooksville Ridge

Total Number of Samples Collected: 2 Most Recent Sample Collected: January 1995

Parameter	Units (Detection Limit)	Average Value	District Percentile	Florida Percentile
Chlorophyll a	ug/l (1)	14.5	74	45
Total Phosphorus	mg/l as P (0.01)	0.026	73	16
Total Nitrogen	mg/l as N (0.06)	1.99	84	81
Transparency (Secchi depth)	meters	0.50	9	20
Florida Trophic State Index		43	58	20
Specific Conductance	S/cm at 25C (1)	180	50	48
pH	standard units (0.1)	7.3	50	45
Color	PtCo units (1)	78	85	65
Turbidity	NTU (1)	6.1	78	56
Total Alkalinity	mg/l as CaCO3 (1)	8	21	22
Hardness	mg/l as CaCO3 (0.02)	45	46	
Total Suspended Solids	mg/l (0.05)	6.5	84	
Ammonia	mg/l as N (0.03)	0.015	60	
Nitrate+Nitrite	mg/l as N (0.01)	0.018	48	
Total Kjeldahl Nitrogen	mg/l as N (0.06)	1.97	89	
Orthophosphorus	mg/l as P (0.01)	0.010	59	
Chloride	mg/l (0.05)	24	74	
Sulfate	mg/l (0.05)	29	75	
Sodium	mg/l (0.06)	7.7	41	
Potassium	mg/l (0.07)	11.0	91	
Calcium	mg/l (0.04)	9.4	37	
Magnesium	mg/l (0.006)	5.2	71	
Iron	ug/l (0.03)	34	45	

Based upon the average FTSI of 43, water quality is considered good. King (East) Lake can be characterized as a colored, soft water, mesotrophic lake, with high concentrations of total nitrogen. The chemical type of water (predominant ionic composition) is calcium chloride.

Plots and Trends: King Lake surface elevations declined to period-of-record lows during the early to mid-1990s. Overall, however, there is no long-term trend in lake levels for the relatively short period of record. Also shown is a diagram of the relative ionic composition of the lake water.

MONTHLY AVERAGE SURFACE ELEVATION

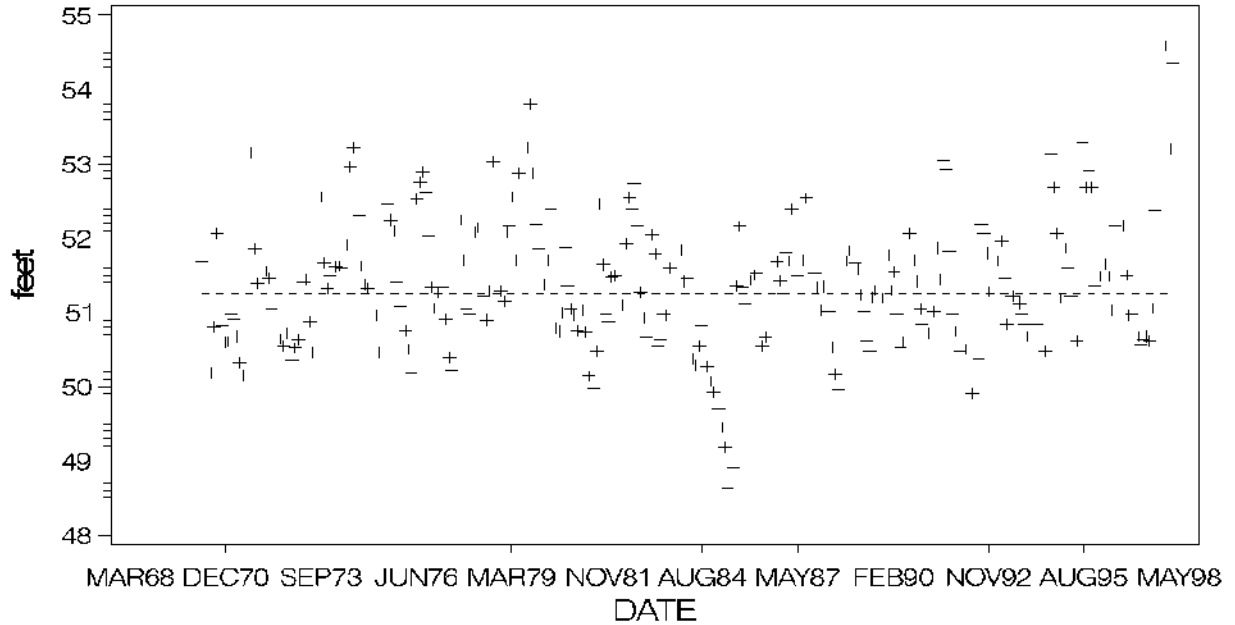

MAJOR IONS (% meq/l)

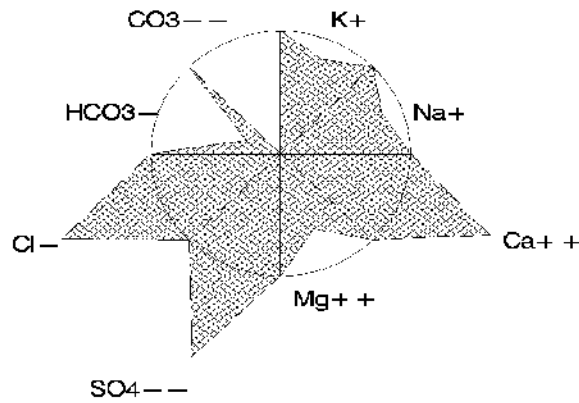

King (East) Lake, Pasco County

Loyce Lake

Pasco County

USGS Quadrangle: Ehren Major Land Use/Land Cover (1990)
 Section/Township/Range: 22-24S-18E within 500 meters of the lakeshore:
 Approx. Lake Center, Lat/Long: 282230/822943 - hardwood - conifer mixed (32%)
 Surface Area: 45 acres - cropland and pastureland (25%)
 Approx. Lake Elevation: 63 feet - freshwater marshes (14%)
 Lake Type: inflow and outflow (type 3)
 Major Basin: Upper Coastal Drainage
 Minor Basin: Jumping Gully
 Lake Region: Tampa Plain

Total Number of Samples Collected: 2 Most Recent Sample Collected: January 1996

Parameter	Units (Detection Limit)	Average Value	District Percentile	Florida Percentile
Chlorophyll a	ug/l (1)	15.9	75	47
Total Phosphorus	mg/l as P (0.01)	0.005	31	<5
Total Nitrogen	mg/l as N (0.06)	2.59	92	89
Transparency (Secchi depth)	meters	0.75	21	45
Florida Trophic State Index		42	57	19
Specific Conductance	S/cm at 25C (1)	141	31	40
pH	standard units (0.1)	7.2	43	40
Color	PtCo units (1)	50	79	40
Turbidity	NTU (1)	2.8	61	30
Total Alkalinity	mg/l as CaCO3 (1)	57	85	66
Hardness	mg/l as CaCO3 (0.02)	61	63	
Total Suspended Solids	mg/l (0.05)	3.5	67	
Ammonia	mg/l as N (0.03)	0.291	>95	
Nitrate+Nitrite	mg/l as N (0.01)	0.022	54	
Total Kjeldahl Nitrogen	mg/l as N (0.06)	2.57	>95	
Orthophosphorus	mg/l as P (0.01)	0.005	56	
Chloride	mg/l (0.05)	6	5	
Sulfate	mg/l (0.05)	3	14	
Sodium	mg/l (0.06)	3.7	7	
Potassium	mg/l (0.07)	1.5	25	
Calcium	mg/l (0.04)	21.5	80	
Magnesium	mg/l (0.006)	1.6	18	
Iron	ug/l (0.03)	198	92	

Based upon the average FTSI of 42, water quality is considered good. Loyce Lake can be characterized as a colored, medium hard water, meso-eutrophic lake, with low concentrations of total phosphorus and high concentrations of total nitrogen. The chemical type of water (predominant ionic composition) is calcium bicarbonate. Lake Loyce has been augmented with water from the Floridan Aquifer.

Plots and Trends: No or insufficient data available for plotting or trend detection. Shown is a diagram of the relative ionic composition of the lake water.

MAJOR IONS (% meq/l)

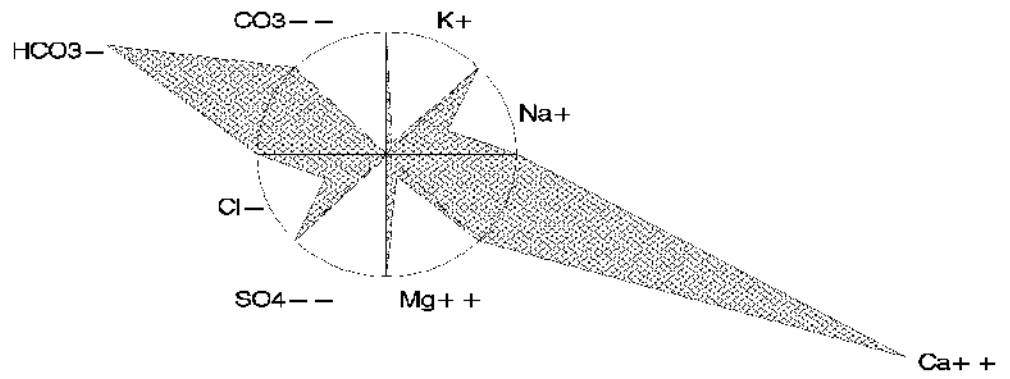

Loyce Lake, Pasco County

Middle Lake

Pasco County

USGS Quadrangle: Spring Lake Major Land Use/Land Cover (1990)
 Section/Township/Range: 4-24S-20E within 500 meters of the lakeshore:
 Approx. Lake Center, Lat/Long: 282517/821855 - other open lands - rural (35%)
 Surface Area: 215 acres - hardwood - conifer mixed (20%)
 Approx. Lake Elevation: 107 feet - stream and lake swamps (17%)
 Lake Type: inflow and outflow (type 3)
 Major Basin: Upper Coastal Drainage
 Minor Basin: Crews Lake Outlet
 Lake Region: Southern Brooksville Ridge
 Public Access: yes

Total Number of Samples Collected: 2 Most Recent Sample Collected: February 1997

Parameter	Units (Detection Limit)	Average Value	District Percentile	Florida Percentile
Chlorophyll a	ug/l (1)	9.3	61	36
Total Phosphorus	mg/l as P (0.01)	0.016	56	8
Total Nitrogen	mg/l as N (0.06)	0.89	31	30
Transparency (Secchi depth)	meters	0.95	31	62
Florida Trophic State Index		46	65	27
Specific Conductance	S/cm at 25C (1)	134	27	37
pH	standard units (0.1)	7.6	64	57
Color	PtCo units (1)	40	72	30
Turbidity	NTU (1)	3.3	65	35
Total Alkalinity	mg/l as CaCO3 (1)	27	54	46
Hardness	mg/l as CaCO3 (0.02)	45	46	
Total Suspended Solids	mg/l (0.05)	3.5	67	
Ammonia	mg/l as N (0.03)	0.025	60	
Nitrate+Nitrite	mg/l as N (0.01)	0.037	63	
Total Kjeldahl Nitrogen	mg/l as N (0.06)	0.86	36	
Orthophosphorus	mg/l as P (0.01)	0.005	56	
Chloride	mg/l (0.05)	17	41	
Sulfate	mg/l (0.05)	7	27	
Sodium	mg/l (0.06)	5.6	18	
Potassium	mg/l (0.07)	4.4	60	
Calcium	mg/l (0.04)	9.8	39	
Magnesium	mg/l (0.006)	5.1	70	
Iron	ug/l (0.03)	39	52	

Based upon the average FTSI of 46, water quality is considered good. Middle Lake can be characterized as a colored, soft water, meso-eutrophic lake. The chemical type of water (predominant ionic composition) is calcium chloride.

Plots and Trends: Recent lake elevations in Middle Lake were higher than at any other time during the 18 year period of record. Also shown is a diagram of the relative ionic composition of the lake water.

MONTHLY AVERAGE SURFACE ELEVATION

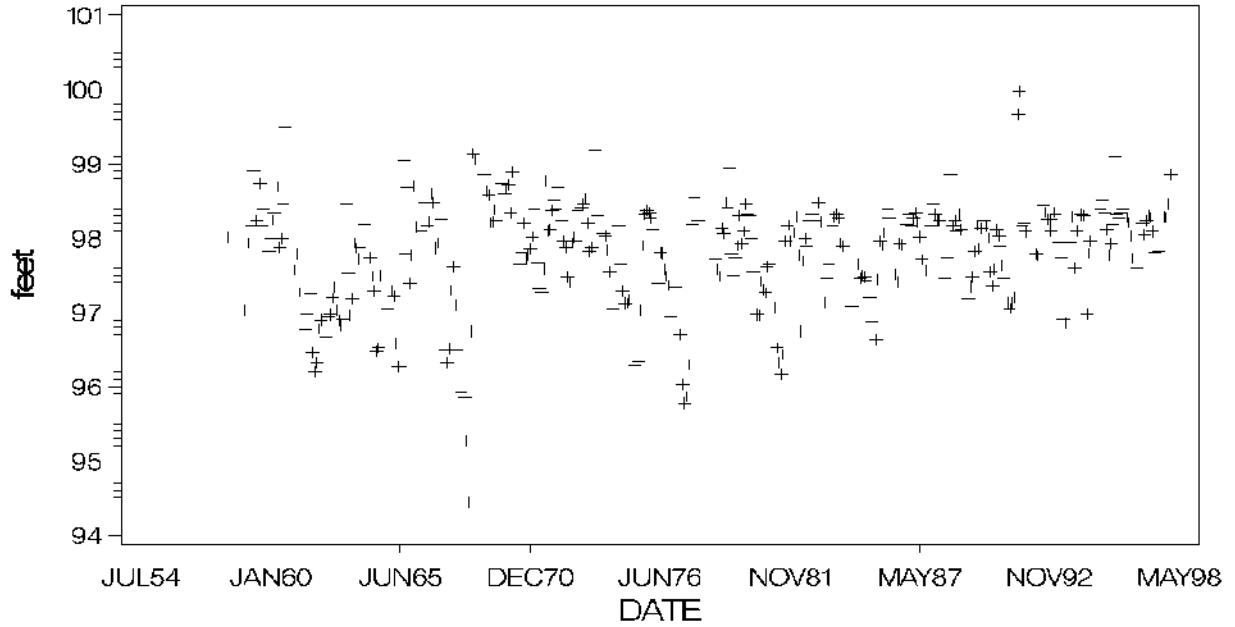

MAJOR IONS (% meq/l)

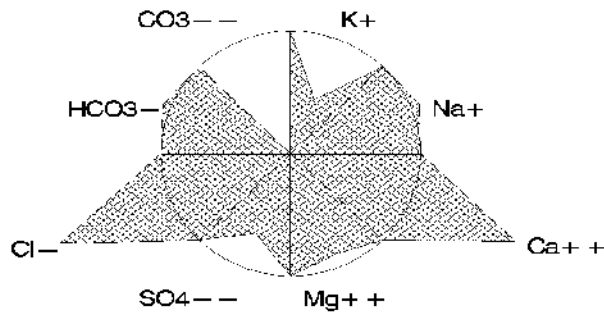

Moody Lake (East) Pasco County

USGS Quadrangle:	Spring Lake	Major Land Use/Land Cover (1990)
Section/Township/Range:	10-24S-20E	within 500 meters of the lakeshore:
Approx. Lake Center, Lat/Long:	282431/821740	- stream and lake swamps (32%)
Surface Area:	105 acres	- hardwood - conifer mixed (20%)
Approx. Lake Elevation:	110 feet	- other open lands - rural (18%)
Lake Type:	inflow and outflow (type 3)	
Major Basin:	Upper Coastal Drainage	
Minor Basin:	Crews Lake Outlet	
Lake Region:	Southern Brooksville Ridge	

Total Number of Samples Collected: 2 Most Recent Sample Collected: January 1995

Parameter	Units (Detection Limit)	Average Value	District Percentile	Florida Percentile
Chlorophyll a	ug/l (1)	1.1	<5	<5
Total Phosphorus	mg/l as P (0.01)	0.017	58	9
Total Nitrogen	mg/l as N (0.06)	1.32	62	46
Transparency (Secchi depth)	meters		-	-
Florida Trophic State Index		19	<5	<5
Specific Conductance	S/cm at 25C (1)	129	24	35
pH	standard units (0.1)	8.3	87	78
Color	PtCo units (1)	78	85	65
Turbidity	NTU (1)	0.5	28	<5
Total Alkalinity	mg/l as CaCO3 (1)	24	48	43
Hardness	mg/l as CaCO3 (0.02)	44	43	
Total Suspended Solids	mg/l (0.05)	0.4	8	
Ammonia	mg/l as N (0.03)	0.015	60	
Nitrate+Nitrite	mg/l as N (0.01)	0.005	33	
Total Kjeldahl Nitrogen	mg/l as N (0.06)	1.32	69	
Orthophosphorus	mg/l as P (0.01)	0.005	56	
Chloride	mg/l (0.05)	17	41	
Sulfate	mg/l (0.05)	3	14	
Sodium	mg/l (0.06)	6.1	23	
Potassium	mg/l (0.07)	0.9	17	
Calcium	mg/l (0.04)	8.6	31	
Magnesium	mg/l (0.006)	5.5	73	
Iron	ug/l (0.03)	36	48	

Based upon the average FTSI of 19, water quality is considered good. Moody Lake (East) can be characterized as a colored, soft water, oligotrophic lake. The chemical type of water (predominant ionic composition) is calcium chloride.

Also of note:

- The measured pH was high.
- Hydrilla was observed in the lake.

Plots and Trends: Moody Lake (East) is joined to Moody Lake (West). There is no trend evident in the plot of lake surface elevation. Also shown is a diagram of the relative ionic composition of the lake water.

MONTHLY AVERAGE SURFACE ELEVATION

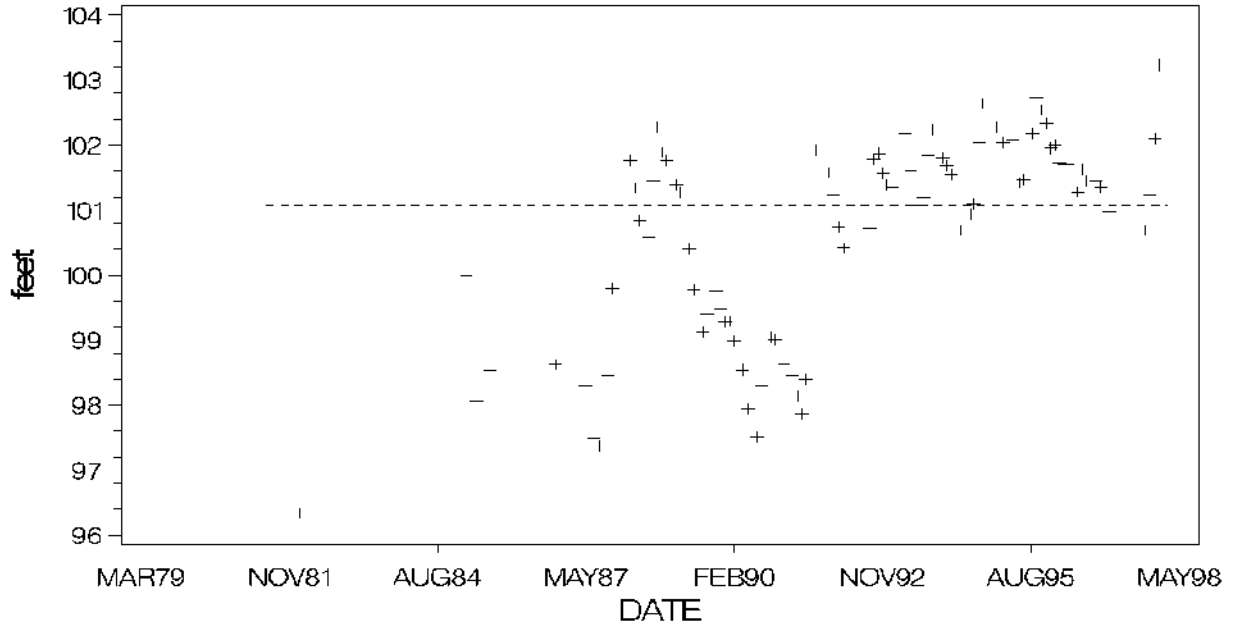

MAJOR IONS (% meq/l)

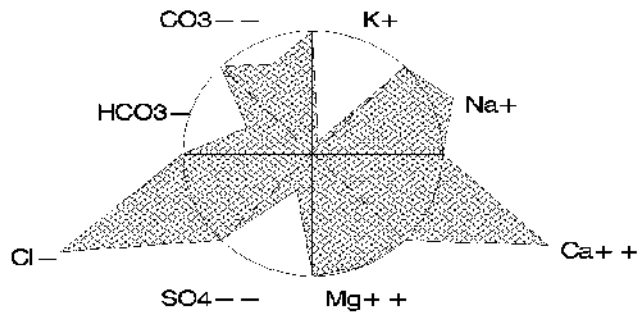

Moody Lake (East), Pasco County

Moody Lake (West) Pasco County

USGS Quadrangle: Spring Lake Major Land Use/Land Cover (1990)
 Section/Township/Range: 10-24S-20E within 500 meters of the lakeshore:
 Approx. Lake Center, Lat/Long: 282445/821804 - other open lands - rural (20%)
 Surface Area: 100 acres - stream and lake swamps (18%)
 Approx. Lake Elevation: 110 feet - hardwood - conifer mixed (18%)
 Lake Type: inflow and outflow (type 3)
 Major Basin: Upper Coastal Drainage
 Minor Basin: Crews Lake Outlet
 Lake Region: Southern Brooksville Ridge

Total Number of Samples Collected: 2 Most Recent Sample Collected: January 1995

Parameter	Units (Detection Limit)	Average Value	District Percentile	Florida Percentile
Chlorophyll a	ug/l (1)	3.4	30	14
Total Phosphorus	mg/l as P (0.01)	0.005	31	<5
Total Nitrogen	mg/l as N (0.06)	0.61	9	16
Transparency (Secchi depth)	meters		-	-
Florida Trophic State Index		30	27	<5
Specific Conductance	S/cm at 25C (1)	137	30	38
pH	standard units (0.1)	8.4	90	80
Color	PtCo units (1)	18	51	15
Turbidity	NTU (1)	0.5	28	<5
Total Alkalinity	mg/l as CaCO3 (1)	27	54	46
Hardness	mg/l as CaCO3 (0.02)	48	50	
Total Suspended Solids	mg/l (0.05)	1.6	42	
Ammonia	mg/l as N (0.03)	0.015	60	
Nitrate+Nitrite	mg/l as N (0.01)	0.005	33	
Total Kjeldahl Nitrogen	mg/l as N (0.06)	0.61	16	
Orthophosphorus	mg/l as P (0.01)	0.005	56	
Chloride	mg/l (0.05)	19	51	
Sulfate	mg/l (0.05)	3	14	
Sodium	mg/l (0.06)	6.5	27	
Potassium	mg/l (0.07)	1.7	28	
Calcium	mg/l (0.04)	11.0	43	
Magnesium	mg/l (0.006)	4.9	68	
Iron	ug/l (0.03)	23	27	

Based upon the average FTSI of 30, water quality is considered good. Moody Lake (West) can be characterized as a clear to moderately colored (10<color<20 color units), soft water, oligo-mesotrophic lake, with low concentrations of total phosphorus, low concentrations of total nitrogen. The chemical type of water (predominant ionic composition) is calcium chloride.

Also of note:

- The measured pH was high
- Hydrilla was observed in the lake.

Plots and Trends: Moody Lake (West) is joined with Moody Lake (East). There is no trend evident in the plot of lake surface elevation. Also shown is a diagram of the relative ionic composition of the lake water.

MONTHLY AVERAGE SURFACE ELEVATION

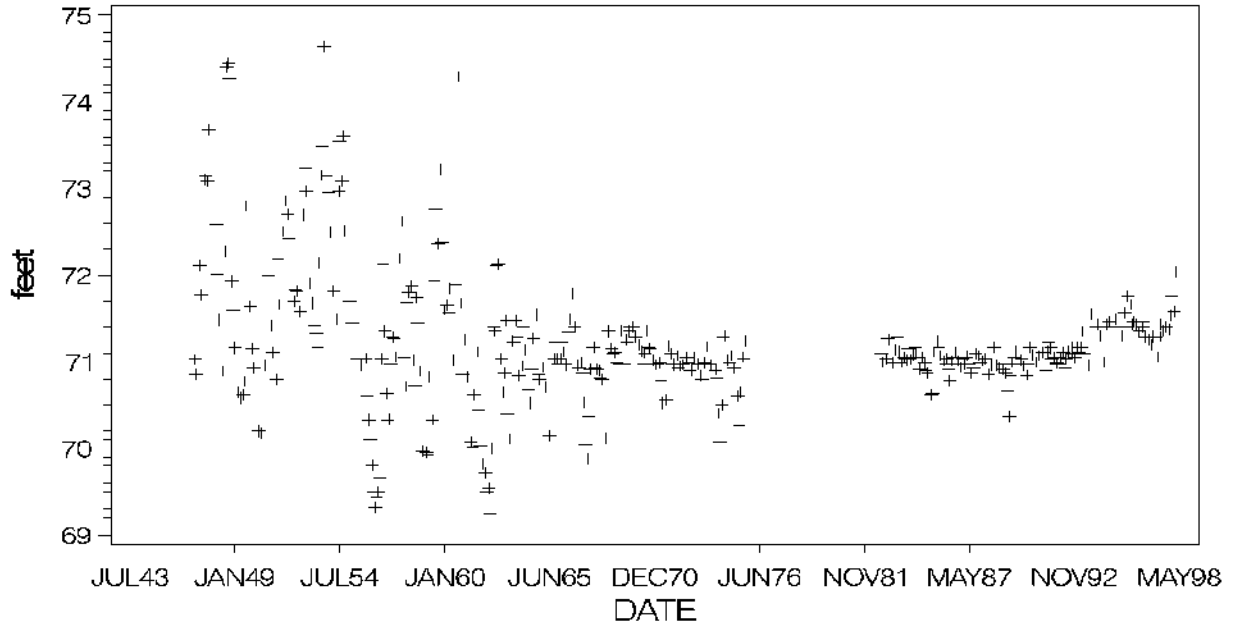

MAJOR IONS (% meq/l)

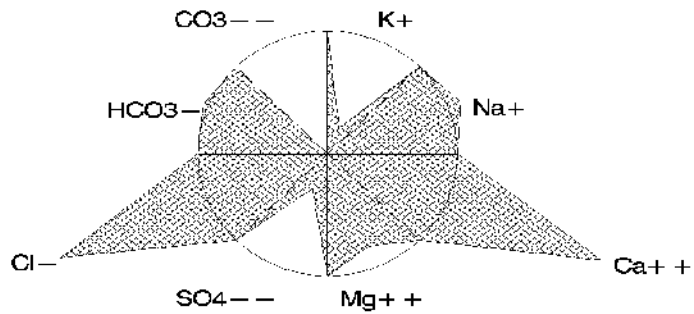

Moody Lake (West), Pasco County

Moon Lake

Pasco County

USGS Quadrangle: Fivay Junction Major Land Use/Land Cover (1990)
 Section/Township/Range: 28-25S-17E within 500 meters of the lakeshore:
 Approx. Lake Center, Lat/Long: 281706/823639 - medium density residential (50%)
 Surface Area: 99 acres - pine flatwoods (13%)
 Approx. Lake Elevation: 93 feet - cypress (11%)
 Observed Maximum Depth: 19.7 feet
 (reference elevation 92.94 feet)
 Lake Type: inflow (type 1)
 Major Basin: Upper Coastal Drainage
 Minor Basin: Pithlachascotee River
 Lake Region: Weeki Wachee Hills
 Public Access: yes

Total Number of Samples Collected: 2 Most Recent Sample Collected: January 1996

Parameter	Units (Detection Limit)	Average Value	District Percentile	Florida Percentile
Chlorophyll a	ug/l (1)	9.1	60	35
Total Phosphorus	mg/l as P (0.01)	0.005	31	<5
Total Nitrogen	mg/l as N (0.06)	0.95	37	32
Transparency (Secchi depth)	meters	1.75	57	81
Florida Trophic State Index		43	58	20
Specific Conductance	S/cm at 25C (1)	129	24	35
pH	standard units (0.1)	7.3	50	45
Color	PtCo units (1)	23	58	19
Turbidity	NTU (1)	3.4	66	36
Total Alkalinity	mg/l as CaCO3 (1)	17	39	35
Hardness	mg/l as CaCO3 (0.02)	27	18	
Total Suspended Solids	mg/l (0.05)	3.3	66	
Ammonia	mg/l as N (0.03)	0.113	90	
Nitrate+Nitrite	mg/l as N (0.01)	0.028	58	
Total Kjeldahl Nitrogen	mg/l as N (0.06)	0.92	40	
Orthophosphorus	mg/l as P (0.01)	0.005	56	
Chloride	mg/l (0.05)	24	74	
Sulfate	mg/l (0.05)	6	23	
Sodium	mg/l (0.06)	14.0	80	
Potassium	mg/l (0.07)	1.1	20	
Calcium	mg/l (0.04)	8.3	29	
Magnesium	mg/l (0.006)	1.4	15	
Iron	ug/l (0.03)	36	48	

Based upon the average FTSI of 43, water quality is considered good. Moon Lake can be characterized as a moderately colored, soft water, eutrophic lake, with low concentrations of total phosphorus. The chemical type of water (predominant ionic composition) is sodium chloride.

Plots and Trends: Though there are insufficient data to make a conclusion, the plots suggest that total alkalinity, total hardness, and specific conductance have increased somewhat over the period of record. Also shown is a diagram of the relative ionic composition of the lake water.

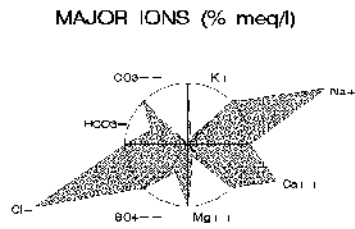
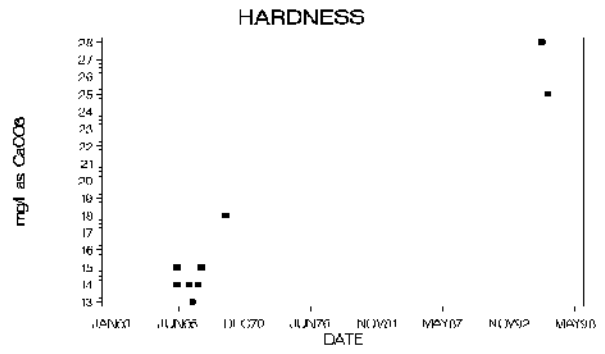
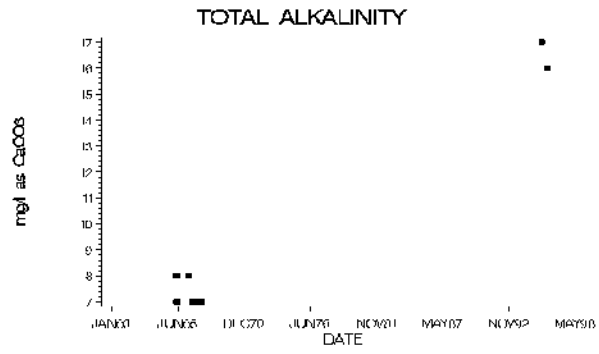
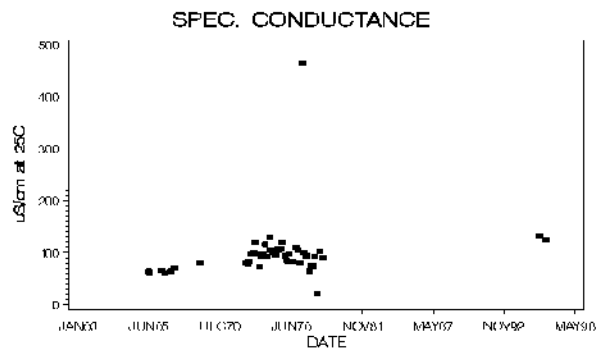
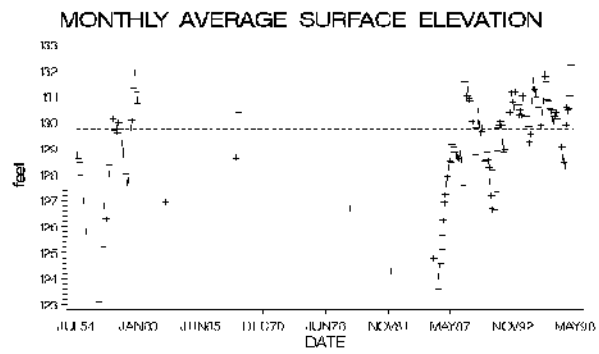

Moon Lake, Pasco County

Moss Lake

Pasco County

USGS Quadrangle: Lutz Major Land Use/Land Cover (1990)
 Section/Township/Range: 35-26S-18E within 500 meters of the lakeshore:
 Approx. Lake Center, Lat/Long: 281034/822856 - medium density residential (33%)
 Surface Area: 33 acres - cropland and pastureland (23%)
 Approx. Lake Elevation: 64 feet - tree crops, typically citrus (11%)
 Lake Type: inflow and outflow (type 3)
 Major Basin: Tampa Bay Drainage
 Minor Basin: Upper Rocky Creek
 Lake Region: Land-o-Lakes

Total Number of Samples Collected: 2 Most Recent Sample Collected: January 1995

Parameter	Units (Detection Limit)	Average Value	District Percentile	Florida Percentile
Chlorophyll a	ug/l (1)	2.0	13	8
Total Phosphorus	mg/l as P (0.01)	0.008	31	<5
Total Nitrogen	mg/l as N (0.06)	2.14	86	83
Transparency (Secchi depth)	meters	2.90	81	95
Florida Trophic State Index		26	17	<5
Specific Conductance	S/cm at 25C (1)	164	44	45
pH	standard units (0.1)	7.4	57	50
Color	PtCo units (1)	8	24	8
Turbidity	NTU (1)	0.9	28	<5
Total Alkalinity	mg/l as CaCO3 (1)	24	48	43
Hardness	mg/l as CaCO3 (0.02)	39	34	
Total Suspended Solids	mg/l (0.05)	1.8	47	
Ammonia	mg/l as N (0.03)	0.074	83	
Nitrate+Nitrite	mg/l as N (0.01)	0.005	33	
Total Kjeldahl Nitrogen	mg/l as N (0.06)	2.13	92	
Orthophosphorus	mg/l as P (0.01)	0.005	56	
Chloride	mg/l (0.05)	23	69	
Sulfate	mg/l (0.05)	14	48	
Sodium	mg/l (0.06)	14.5	82	
Potassium	mg/l (0.07)	1.0	18	
Calcium	mg/l (0.04)	12.5	51	
Magnesium	mg/l (0.006)	1.9	23	
Iron	ug/l (0.03)	13	6	

Based upon the average FTSI of 26, water quality is considered good. Moss Lake can be characterized as a clear (color<=10 color units), soft water, oligotrophic lake, with low concentrations of total phosphorus and high concentrations of total nitrogen. The chemical type of water (predominant ionic composition) is calcium chloride (1 sample) or sodium chloride (1 sample).

Plots and Trends: No or insufficient data available for plotting or trend detection. Shown is a diagram of the relative ionic composition of the lake water.

MAJOR IONS (% meq/l)

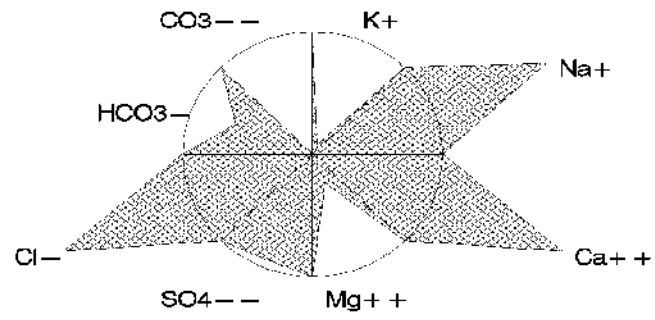

Moss Lake, Pasco County

Lake Padgett Pasco County

USGS Quadrangle: Lutz Major Land Use/Land Cover (1990)
 Section/Township/Range: 24-26S-18E within 500 meters of the lakeshore:
 Approx. Lake Center, Lat/Long: 281220/822737 - medium density residential (28%)
 Surface Area: 200 acres - commercial and services (10%)
 Approx. Lake Elevation: 71 feet - low density residential (9%)
 Average Depth: 8.2 feet
 Observed Maximum Depth: 26.2 feet
 (reference elevation 67 feet)
 Lake Type: inflow and outflow (type 3)
 Major Basin: Hillsborough River
 Minor Basin: Lake Hanna Outlet
 Lake Region: Land-o-Lakes

Total Number of Samples Collected: 2 Most Recent Sample Collected: January 1995

Parameter	Units (Detection Limit)	Average Value	District Percentile	Florida Percentile
Chlorophyll a	ug/l (1)	5.7	47	24
Total Phosphorus	mg/l as P (0.01)	0.017	58	9
Total Nitrogen	mg/l as N (0.06)	1.38	64	49
Transparency (Secchi depth)	meters	3.45	90	>95
Florida Trophic State Index		33	35	7
Specific Conductance	S/cm at 25C (1)	264	81	63
pH	standard units (0.1)	6.7	21	23
Color	PtCo units (1)	8	24	8
Turbidity	NTU (1)	1.4	39	11
Total Alkalinity	mg/l as CaCO3 (1)	8	21	22
Hardness	mg/l as CaCO3 (0.02)	40	36	
Total Suspended Solids	mg/l (0.05)	2.4	57	
Ammonia	mg/l as N (0.03)	0.015	60	
Nitrate+Nitrite	mg/l as N (0.01)	0.034	61	
Total Kjeldahl Nitrogen	mg/l as N (0.06)	1.35	71	
Orthophosphorus	mg/l as P (0.01)	0.005	56	
Chloride	mg/l (0.05)	53	>95	
Sulfate	mg/l (0.05)	24	69	
Sodium	mg/l (0.06)	30.0	>95	
Potassium	mg/l (0.07)	5.1	66	
Calcium	mg/l (0.04)	8.8	33	
Magnesium	mg/l (0.006)	4.3	60	
Iron	ug/l (0.03)	26	32	

Based upon the average FTSI of 33, water quality is considered good. Lake Padgett can be characterized as a clear (color<=10 color units), soft water, mesotrophic lake. The chemical type of water (predominant ionic composition) is sodium chloride.

Plots and Trends: Although specific conductance may have increased slightly over the period of record, plots of water chemistry demonstrate no conclusive change in water chemistry for the available data. Also shown is a diagram of the relative ionic composition of the lake water.

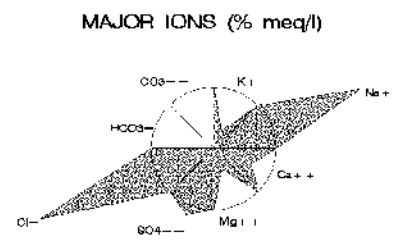
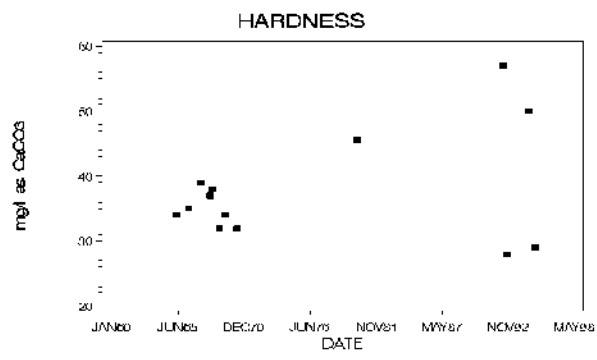
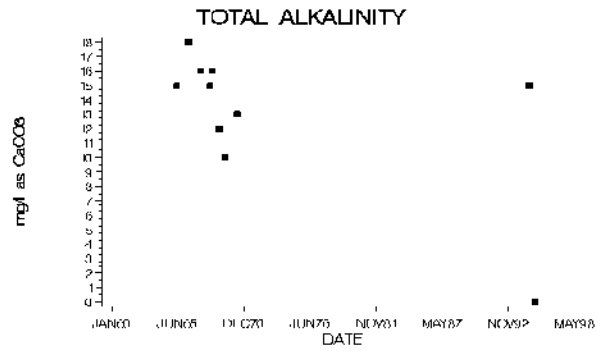
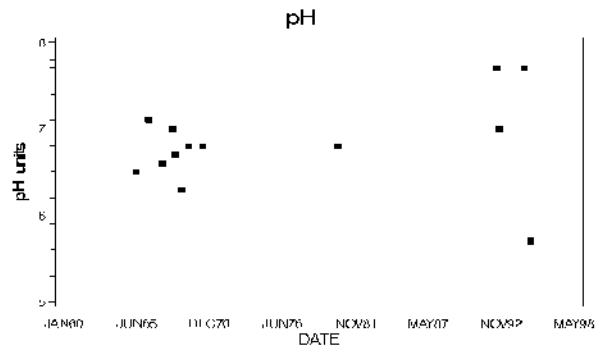
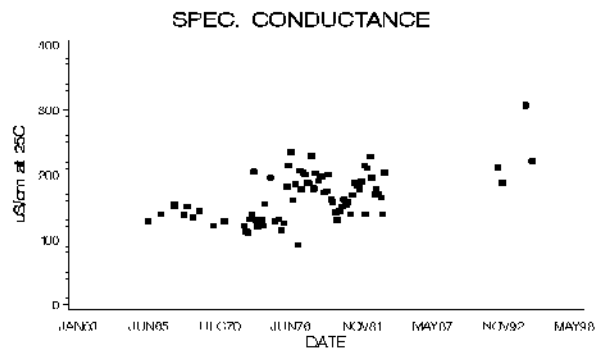
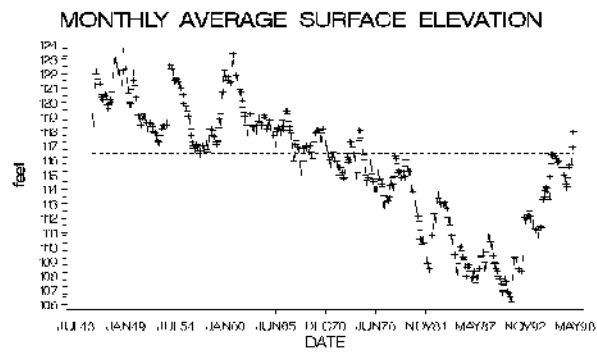

Lake Padgett, Pasco County

Parker Lake

Pasco County

USGS Quadrangle: Odessa Major Land Use/Land Cover (1990)
 Section/Township/Range: 35-26S-17E within 500 meters of the lakeshore:
 Approx. Lake Center, Lat/Long: 281039/823454 - medium density residential (38%)
 Surface Area: 93 acres - tree crops, typically citrus (17%)
 Approx. Lake Elevation: 49 feet - open land (15%)
 Average Depth: 8.9 feet
 (reference elevation 45 feet)
 Lake Type: isolated (type 4)
 Major Basin: Upper Coastal Drainage
 Minor Basin: Lake Ann Outlet
 Lake Region: Keystone Lakes

Total Number of Samples Collected: 2 Most Recent Sample Collected: January 1995

Parameter	Units (Detection Limit)	Average Value	District Percentile	Florida Percentile
Chlorophyll a	ug/l (1)	2.4	17	10
Total Phosphorus	mg/l as P (0.01)	0.013	46	7
Total Nitrogen	mg/l as N (0.06)	1.83	80	77
Transparency (Secchi depth)	meters	1.95	62	84
Florida Trophic State Index		35	39	9
Specific Conductance	S/cm at 25C (1)	167	44	45
pH	standard units (0.1)	7.3	50	45
Color	PtCo units (1)	8	24	8
Turbidity	NTU (1)	2.0	51	20
Total Alkalinity	mg/l as CaCO3 (1)	10	27	25
Hardness	mg/l as CaCO3 (0.02)	25	14	
Total Suspended Solids	mg/l (0.05)	2.6	60	
Ammonia	mg/l as N (0.03)	0.015	60	
Nitrate+Nitrite	mg/l as N (0.01)	0.005	33	
Total Kjeldahl Nitrogen	mg/l as N (0.06)	1.82	86	
Orthophosphorus	mg/l as P (0.01)	0.005	56	
Chloride	mg/l (0.05)	31	87	
Sulfate	mg/l (0.05)	13	45	
Sodium	mg/l (0.06)	15.5	85	
Potassium	mg/l (0.07)	1.8	30	
Calcium	mg/l (0.04)	6.4	22	
Magnesium	mg/l (0.006)	2.1	28	
Iron	ug/l (0.03)	33	43	

Based upon the average FTSI of 35, water quality is considered good. Parker Lake can be characterized as a clear (color<=10 color units), soft water, oligo-mesotrophic lake, with high concentrations of total nitrogen. The chemical type of water (predominant ionic composition) is sodium chloride.

Plots and Trends: The specific conductance for recent samples was greater than for observations made during the 1970s. Also shown are a plot of lake surface elevation and a diagram of the relative ionic composition of the lake water.

MONTHLY AVERAGE SURFACE ELEVATION

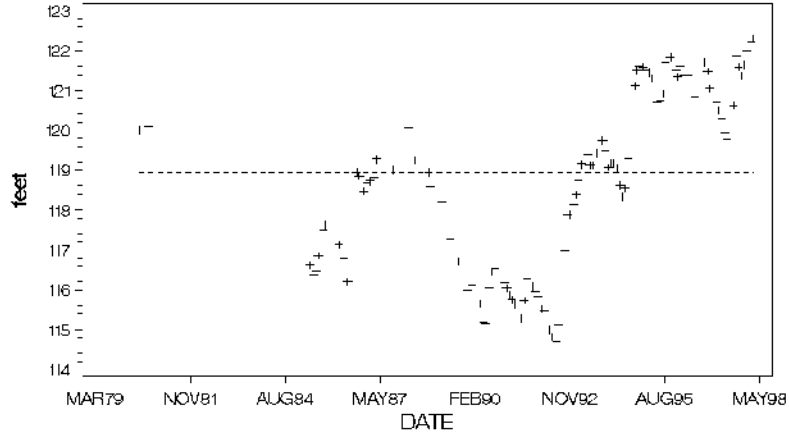

SPEC. CONDUCTANCE

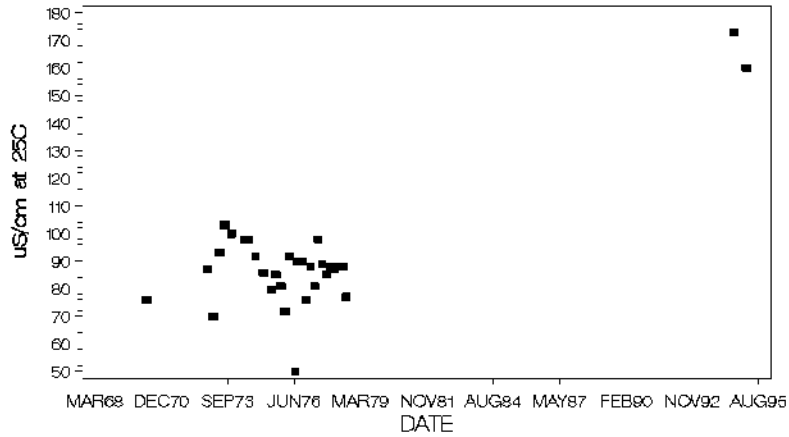

MAJOR IONS (% meq/l)

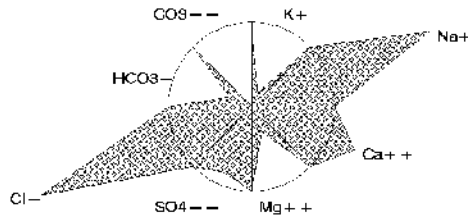

Lake Pasadena Pasco County

USGS Quadrangle:	Dade City	Major Land Use/Land Cover (1990)
Section/Township/Range:	16-25S-21E	within 500 meters of the lakeshore:
Approx. Lake Center, Lat/Long:	281912/821320	- cropland and pastureland (27%)
Surface Area:	373 acres	- freshwater marshes (16%)
Approx. Lake Elevation:	95 feet	- tree crops, typically citrus (12%)

Observed Maximum Depth: 6.6 feet
(reference elevation not given)

Lake Type: isolated (type 4)

Major Basin: Hillsborough River

Minor Basin: Noncontributing Area

Lake Region: Southern Brooksville Ridge

Public Access: yes

Total Number of Samples Collected: 2 Most Recent Sample Collected: January 1996

Parameter	Units (Detection Limit)	Average Value	District Percentile	Florida Percentile
Chlorophyll a	ug/l (1)	6.5	51	28
Total Phosphorus	mg/l as P (0.01)	0.005	31	<5
Total Nitrogen	mg/l as N (0.06)	1.83	80	77
Transparency (Secchi depth)	meters		-	-
Florida Trophic State Index		40	53	16
Specific Conductance	S/cm at 25C (1)	139	31	39
pH	standard units (0.1)	8.8	95	90
Color	PtCo units (1)	60	82	50
Turbidity	NTU (1)	0.8	28	<5
Total Alkalinity	mg/l as CaCO3 (1)	15	36	33
Hardness	mg/l as CaCO3 (0.02)	38	32	
Total Suspended Solids	mg/l (0.05)	0.8	21	
Ammonia	mg/l as N (0.03)	0.023	60	
Nitrate+Nitrite	mg/l as N (0.01)	0.023	56	
Total Kjeldahl Nitrogen	mg/l as N (0.06)	1.80	85	
Orthophosphorus	mg/l as P (0.01)	0.005	56	
Chloride	mg/l (0.05)	24	74	
Sulfate	mg/l (0.05)	6	23	
Sodium	mg/l (0.06)	8.1	45	
Potassium	mg/l (0.07)	3.9	54	
Calcium	mg/l (0.04)	6.3	21	
Magnesium	mg/l (0.006)	5.5	73	
Iron	ug/l (0.03)	47	59	

Based upon the average FTSI of 40, water quality is considered good. Lake Pasadena can be characterized as a colored, soft water, mesotrophic lake, with low concentrations of total phosphorus and high concentrations of total nitrogen. The chemical type of water (predominant ionic composition) is sodium chloride.

Also of note:

- The measured pH was high.
- Hydrilla and waterhyacinth were observed.
- Cattails dominate more than 30% of the lake shoreline.

Plots and Trends: Lake Pasadena surface elevation dropped between 1988 and 1992, similar to nearby King Lake and Clear (Jovita) Lake, though more precipitously. Also shown is a diagram of the relative ionic composition of the lake water.

MONTHLY AVERAGE SURFACE ELEVATION

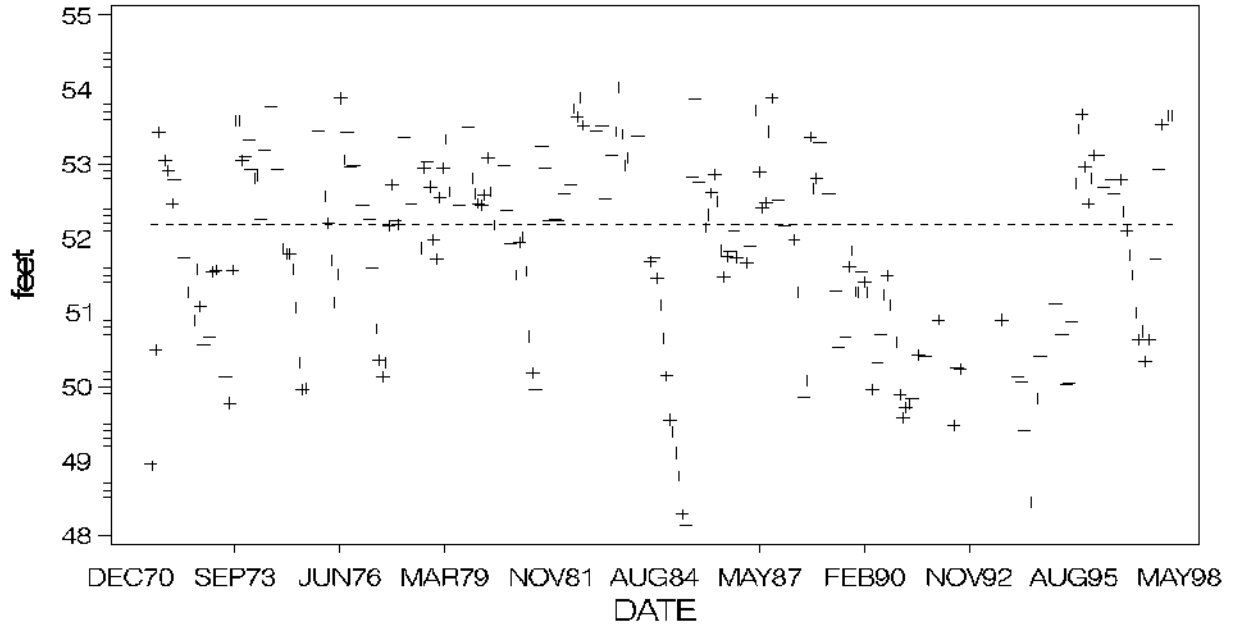

MAJOR IONS (% meq/l)

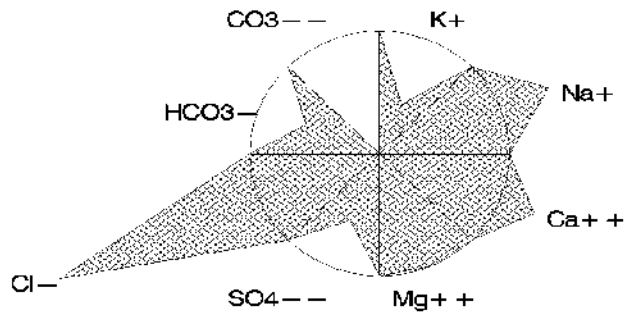

Pierce Lake

Pasco County

USGS Quadrangle: Fivay Junction Major Land Use/Land Cover (1990)
 Section/Township/Range: 9-25S-18E within 500 meters of the lakeshore:
 Approx. Lake Center, Lat/Long: 281916/823050 - low density residential (30%)
 Surface Area: 39 acres - pine flatwoods (21%)
 Approx. Lake Elevation: 73 feet - cropland and pastureland (11%)
 Average Depth: 5 feet
 Observed Maximum Depth: 10 feet
 (reference elevation 69 feet)
 Lake Type: isolated (type 4)
 Major Basin: Upper Coastal Drainage
 Minor Basin: Gowers Corner Slough
 Lake Region: Weeki Wachee Hills

Total Number of Samples Collected: 2 Most Recent Sample Collected: January 1995

Parameter	Units (Detection Limit)	Average Value	District Percentile	Florida Percentile
Chlorophyll a	ug/l (1)	3.7	33	15
Total Phosphorus	mg/l as P (0.01)	0.005	31	<5
Total Nitrogen	mg/l as N (0.06)	0.96	37	32
Transparency (Secchi depth)	meters	2.10	67	87
Florida Trophic State Index		25	14	<5
Specific Conductance	S/cm at 25C (1)	59	<5	8
pH	standard units (0.1)	6.0	5	8
Color	PtCo units (1)	23	58	19
Turbidity	NTU (1)	0.8	28	<5
Total Alkalinity	mg/l as CaCO3 (1)	5	13	13
Hardness	mg/l as CaCO3 (0.02)	12	<5	
Total Suspended Solids	mg/l (0.05)	1.2	33	
Ammonia	mg/l as N (0.03)	0.039	68	
Nitrate+Nitrite	mg/l as N (0.01)	0.010	34	
Total Kjeldahl Nitrogen	mg/l as N (0.06)	0.95	43	
Orthophosphorus	mg/l as P (0.01)	0.005	56	
Chloride	mg/l (0.05)	8	9	
Sulfate	mg/l (0.05)	5	20	
Sodium	mg/l (0.06)	4.9	12	
Potassium	mg/l (0.07)	0.6	13	
Calcium	mg/l (0.04)	3.2	6	
Magnesium	mg/l (0.006)	0.9	<5	
Iron	ug/l (0.03)	29	36	

Based upon the average FTSI of 25, water quality is considered good. Pierce Lake can be characterized as a moderately colored, soft water, oligo-mesotrophic lake, with low concentrations of total phosphorus. The chemical type of water (predominant ionic composition) is sodium chloride.

Also of note:

- The measured pH was low - -

Plots and Trends: No or insufficient data available for plotting or trend detection. Shown is a diagram of the relative ionic composition of the lake water.

MAJOR IONS (% meq/l)

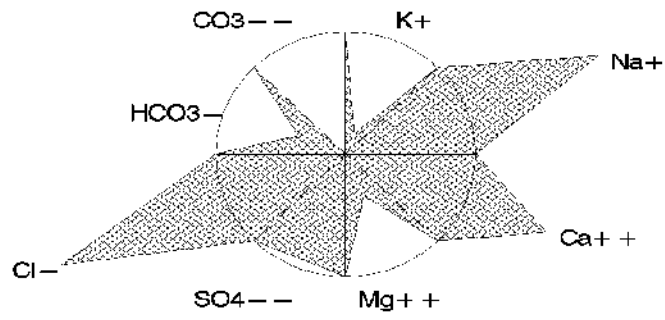

Sumner Lake

Pasco County

USGS Quadrangle: Dade City Major Land Use/Land Cover (1990)
 Section/Township/Range: 36-24S-21E within 500 meters of the lakeshore:
 Approx. Lake Center, Lat/Long: 282136/820942 - cropland and pastureland (34%)
 Surface Area: 65 acres - freshwater marshes (17%)
 Approx. Lake Elevation: 72 feet - other open lands - rural (10%)
 Lake Type: inflow and outflow (type 3)
 Major Basin: Withlacoochee River
 Minor Basin: Tank Lake Outlet
 Lake Region: Southern Brooksville Ridge

Total Number of Samples Collected: 1 Most Recent Sample Collected: February 1997

Parameter	Units (Detection Limit)	Average Value	District Percentile	Florida Percentile
Chlorophyll a	ug/l (1)	3.5	31	14
Total Phosphorus	mg/l as P (0.01)	0.005	31	<5
Total Nitrogen	mg/l as N (0.06)	1.20	55	40
Transparency (Secchi depth)	meters	1.63	53	79
Florida Trophic State Index		32	34	6
Specific Conductance	S/cm at 25C (1)	79	7	15
pH	standard units (0.1)	6.2	8	10
Color	PtCo units (1)	60	82	50
Turbidity	NTU (1)	0.5	28	<5
Total Alkalinity	mg/l as CaCO3 (1)	17	39	35
Hardness	mg/l as CaCO3 (0.02)	24	13	
Total Suspended Solids	mg/l (0.05)	0.0	<5	
Ammonia	mg/l as N (0.03)	0.015	60	
Nitrate+Nitrite	mg/l as N (0.01)	0.005	33	
Total Kjeldahl Nitrogen	mg/l as N (0.06)	1.19	62	
Orthophosphorus	mg/l as P (0.01)	0.005	56	
Chloride	mg/l (0.05)	10	15	
Sulfate	mg/l (0.05)	1	6	
Sodium	mg/l (0.06)	6.6	29	
Potassium	mg/l (0.07)	0.5	11	
Calcium	mg/l (0.04)	6.0	20	
Magnesium	mg/l (0.006)	2.1	28	
Iron	ug/l (0.03)	191	91	

Based upon the average FTSI of 32, water quality is considered good. Sumner Lake can be characterized as a colored, soft water, mesotrophic lake, with low concentrations of total phosphorus. The chemical type of water (predominant ionic composition) is calcium chloride.

Plots and Trends: No or insufficient data available for plotting or trend detection. Shown is a diagram of the relative ionic composition of the lake water.

MAJOR IONS (% meq/l)

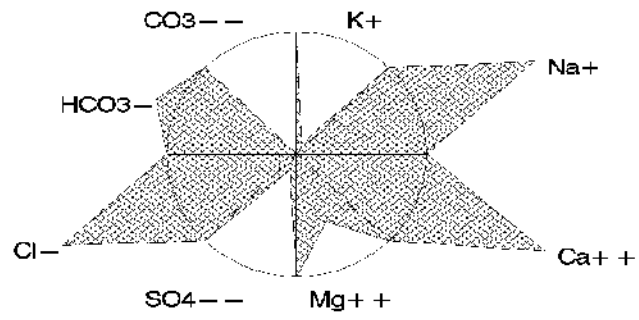

Sumner Lake, Pasco County

Lake Thomas

Pasco County

USGS Quadrangle: Lutz Major Land Use/Land Cover (1990)
 Section/Township/Range: 11-26S-18E within 500 meters of the lakeshore:
 Approx. Lake Center, Lat/Long: 281427/822812 - low density residential (27%)
 Surface Area: 164 acres - rowcrops (11%)
 Approx. Lake Elevation: 75 feet - medium density residential (9%)
 Lake Type: outflow (type 2)
 Major Basin: Upper Coastal Drainage
 Minor Basin: South Branch
 Lake Region: Land-o-Lakes

Total Number of Samples Collected: 2 Most Recent Sample Collected: January 1995

Parameter	Units (Detection Limit)	Average Value	District Percentile	Florida Percentile
Chlorophyll a	ug/l (1)	1.7	8	6
Total Phosphorus	mg/l as P (0.01)	0.010	33	5
Total Nitrogen	mg/l as N (0.06)	0.71	18	21
Transparency (Secchi depth)	meters	4.43	>95	>95
Florida Trophic State Index		17	<5	<5
Specific Conductance	S/cm at 25C (1)	144	33	40
pH	standard units (0.1)	7.2	43	40
Color	PtCo units (1)	8	24	8
Turbidity	NTU (1)	0.5	28	<5
Total Alkalinity	mg/l as CaCO3 (1)	14	33	32
Hardness	mg/l as CaCO3 (0.02)	35	28	
Total Suspended Solids	mg/l (0.05)	0.6	15	
Ammonia	mg/l as N (0.03)	0.015	60	
Nitrate+Nitrite	mg/l as N (0.01)	0.029	59	
Total Kjeldahl Nitrogen	mg/l as N (0.06)	0.71	24	
Orthophosphorus	mg/l as P (0.01)	0.005	56	
Chloride	mg/l (0.05)	22	64	
Sulfate	mg/l (0.05)	13	45	
Sodium	mg/l (0.06)	12.0	69	
Potassium	mg/l (0.07)	2.8	45	
Calcium	mg/l (0.04)	9.2	35	
Magnesium	mg/l (0.006)	3.0	45	
Iron	ug/l (0.03)	20	20	

Based upon the average FTSI of 17, water quality is considered good. Lake Thomas can be characterized as a clear (color<=10 color units), soft water, oligotrophic lake. The chemical type of water (predominant ionic composition) is sodium chloride.

Plots and Trends: Lake surface elevation has been stable over the period of record. Also shown is a diagram of the relative ionic composition of the lake water.

MONTHLY AVERAGE SURFACE ELEVATION

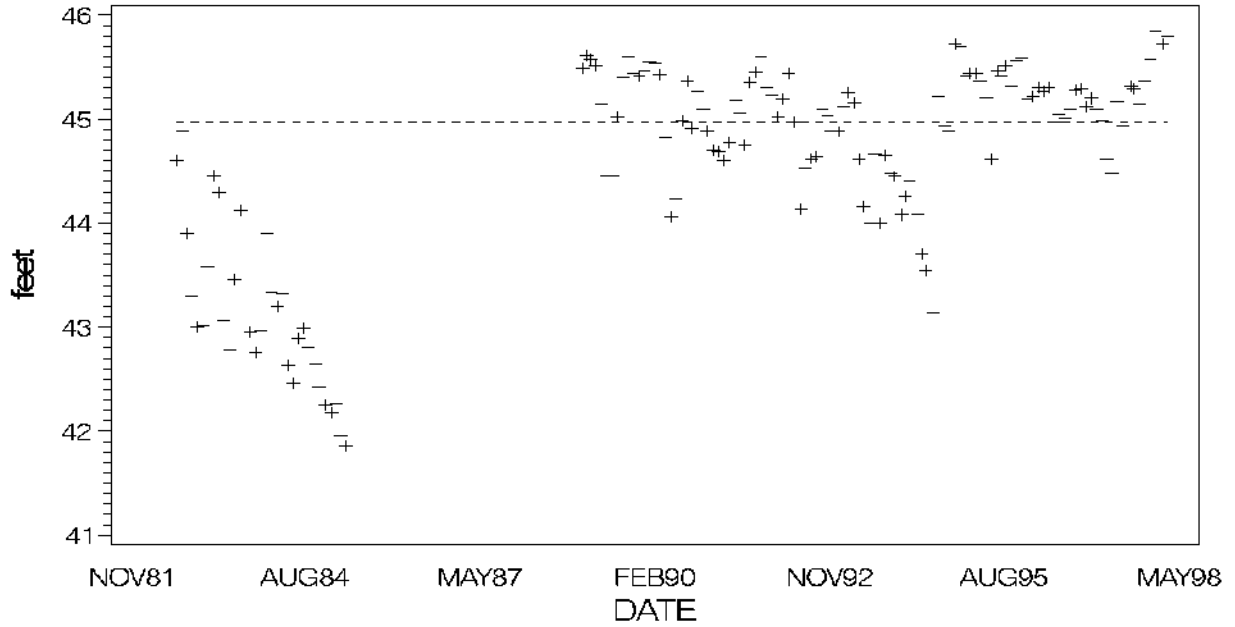

MAJOR IONS (% meq/l)

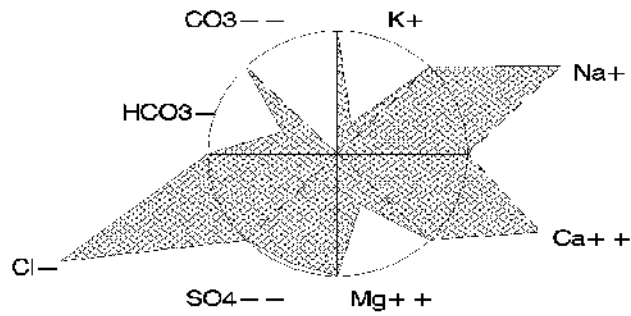

Treasure (Lucy) Lake

Pasco County

USGS Quadrangle: Lutz Major Land Use/Land Cover (1990)
 Section/Township/Range: 1-26S-18E within 500 meters of the lakeshore:
 Approx. Lake Center, Lat/Long: 281453/822740 - medium density residential (23%)
 Surface Area: 26 acres - tree crops, typically citrus (23%)
 Approx. Lake Elevation: 73 feet - cropland and pastureland (11%)
 Lake Type: outflow (type 2)
 Major Basin: Hillsborough River
 Minor Basin: Lake Hanna Outlet
 Lake Region: Land-o-Lakes

Total Number of Samples Collected: 2 Most Recent Sample Collected: January 1995

Parameter	Units (Detection Limit)	Average Value	District Percentile	Florida Percentile
Chlorophyll a	ug/l (1)	1.1	<5	<5
Total Phosphorus	mg/l as P (0.01)	0.005	31	<5
Total Nitrogen	mg/l as N (0.06)	2.15	87	83
Transparency (Secchi depth)	meters	3.00	84	>95
Florida Trophic State Index		19	<5	<5
Specific Conductance	S/cm at 25C (1)	184	52	49
pH	standard units (0.1)	7.2	43	40
Color	PtCo units (1)	10	34	10
Turbidity	NTU (1)	0.9	28	<5
Total Alkalinity	mg/l as CaCO3 (1)	36	67	53
Hardness	mg/l as CaCO3 (0.02)	57	59	
Total Suspended Solids	mg/l (0.05)	0.8	21	
Ammonia	mg/l as N (0.03)	0.015	60	
Nitrate+Nitrite	mg/l as N (0.01)	0.011	37	
Total Kjeldahl Nitrogen	mg/l as N (0.06)	2.14	93	
Orthophosphorus	mg/l as P (0.01)	0.005	56	
Chloride	mg/l (0.05)	22	64	
Sulfate	mg/l (0.05)	12	41	
Sodium	mg/l (0.06)	12.3	71	
Potassium	mg/l (0.07)	1.4	24	
Calcium	mg/l (0.04)	19.5	74	
Magnesium	mg/l (0.006)	2.1	28	
Iron	ug/l (0.03)	19	18	

Based upon the average FTSI of 19, water quality is considered good. Treasure (Lucy) Lake can be characterized as a clear (color<=10 color units), soft water, oligotrophic lake, with low concentrations of total phosphorus and high concentrations of total nitrogen. The chemical type of water (predominant ionic composition) is calcium chloride.

Plots and Trends: No or insufficient data available for plotting or trend detection. Shown is a diagram of the relative ionic composition of the lake water.

MAJOR IONS (% meq/l)

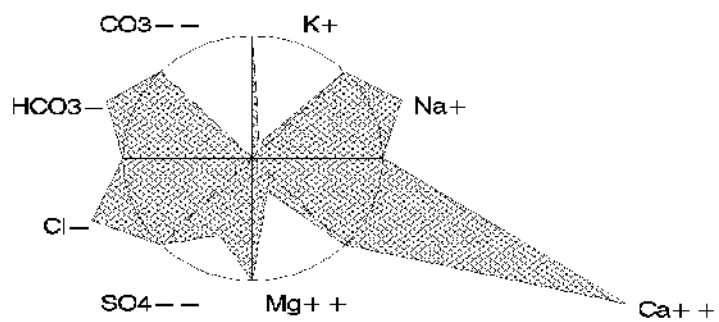

Treasure (Lucy) Lake, Pasco County

Turtle (Tampa) Lake Pasco County

USGS Quadrangle: Lutz Major Land Use/Land Cover (1990)
 Section/Township/Range: 32-26S-19E within 500 meters of the lakeshore:
 Approx. Lake Center, Lat/Long: 281026/822529 - high density residential (26%)
 Surface Area: 65 acres - medium density residential (19%)
 Approx. Lake Elevation: 66 feet - other open lands - rural (13%)
 Lake Type: inflow and outflow (type 3)
 Major Basin: Hillsborough River
 Minor Basin: Cypress Creek
 Lake Region: Land-o-Lakes

Total Number of Samples Collected: 2 Most Recent Sample Collected: January 1996

Parameter	Units (Detection Limit)	Average Value	District Percentile	Florida Percentile
Chlorophyll a	ug/l (1)	1.7	8	6
Total Phosphorus	mg/l as P (0.01)	0.005	31	<5
Total Nitrogen	mg/l as N (0.06)	1.59	72	65
Transparency (Secchi depth)	meters		-	-
Florida Trophic State Index		25	13	<5
Specific Conductance	S/cm at 25C (1)	106	14	25
pH	standard units (0.1)	6.7	21	23
Color	PtCo units (1)	10	34	10
Turbidity	NTU (1)	1.4	39	11
Total Alkalinity	mg/l as CaCO3 (1)	6	15	17
Hardness	mg/l as CaCO3 (0.02)	25	14	
Total Suspended Solids	mg/l (0.05)	0.6	15	
Ammonia	mg/l as N (0.03)	0.033	64	
Nitrate+Nitrite	mg/l as N (0.01)	0.026	57	
Total Kjeldahl Nitrogen	mg/l as N (0.06)	1.57	79	
Orthophosphorus	mg/l as P (0.01)	0.005	56	
Chloride	mg/l (0.05)	15	34	
Sulfate	mg/l (0.05)	15	50	
Sodium	mg/l (0.06)	8.0	44	
Potassium	mg/l (0.07)	2.4	39	
Calcium	mg/l (0.04)	6.8	23	
Magnesium	mg/l (0.006)	1.9	23	
Iron	ug/l (0.03)	39	52	

Based upon the average FTSI of 25, water quality is considered good. Turtle (Tampa) Lake can be characterized as a clear (color<=10 color units), soft water, oligotrophic lake, with low concentrations of total phosphorus. The chemical type of water (predominant ionic composition) is calcium chloride (1 sample) or sodium chloride (1 sample).

Plots and Trends: No or insufficient data available for plotting or trend detection. Shown is a diagram of the relative ionic composition of the lake water.

MAJOR IONS (% meq/l)

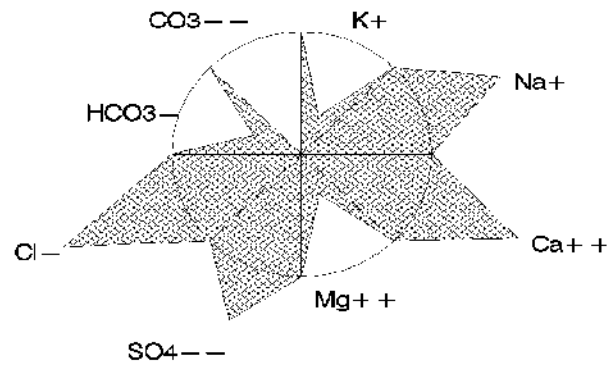

Turtle (Tampa) Lake, Pasco County

Twin Lake

Pasco County

USGS Quadrangle: Lutz Major Land Use/Land Cover (1990)
 Section/Township/Range: 28-26S-19E within 500 meters of the lakeshore:
 Approx. Lake Center, Lat/Long: 281119/822507 - upland coniferous forests (25%)
 Surface Area: 35 acres - hardwood - conifer mixed (15%)
 Approx. Lake Elevation: 68 feet - other open lands - rural (14%)
 Average Depth: 5.2 feet
 Observed Maximum Depth: 10 feet
 (reference elevation 67.1 feet)
 Lake Type: inflow and outflow (type 3)
 Major Basin: Hillsborough River
 Minor Basin: Cypress Creek
 Lake Region: Land-o-Lakes

Total Number of Samples Collected: 2 Most Recent Sample Collected: January 1996

Parameter	Units (Detection Limit)	Average Value	District Percentile	Florida Percentile
Chlorophyll a	ug/l (1)	4.2	39	17
Total Phosphorus	mg/l as P (0.01)	0.005	31	<5
Total Nitrogen	mg/l as N (0.06)	1.19	54	40
Transparency (Secchi depth)	meters	-	-	-
Florida Trophic State Index		31	32	6
Specific Conductance	S/cm at 25C (1)	201	59	52
pH	standard units (0.1)	7.0	34	30
Color	PtCo units (1)	40	72	30
Turbidity	NTU (1)	0.5	28	<5
Total Alkalinity	mg/l as CaCO3 (1)	50	80	62
Hardness	mg/l as CaCO3 (0.02)	71	73	
Total Suspended Solids	mg/l (0.05)	0.2	<5	
Ammonia	mg/l as N (0.03)	0.071	83	
Nitrate+Nitrite	mg/l as N (0.01)	0.010	34	
Total Kjeldahl Nitrogen	mg/l as N (0.06)	1.18	61	
Orthophosphorus	mg/l as P (0.01)	0.005	56	
Chloride	mg/l (0.05)	16	37	
Sulfate	mg/l (0.05)	17	54	
Sodium	mg/l (0.06)	6.6	29	
Potassium	mg/l (0.07)	6.8	80	
Calcium	mg/l (0.04)	23.5	84	
Magnesium	mg/l (0.006)	3.0	45	
Iron	ug/l (0.03)	28	35	

Based upon the average FTSI of 31, water quality is considered good. Twin Lake can be characterized as a colored, medium hard water, mesotrophic lake, with low concentrations of total phosphorus. The chemical type of water (predominant ionic composition) is calcium bicarbonate.

Also of note:

- Cattails dominate more than 30% of the lake shoreline.

Plots and Trends: No or insufficient data available for plotting or trend detection. Shown is a diagram of the relative ionic composition of the lake water.

MAJOR IONS (% meq/l)

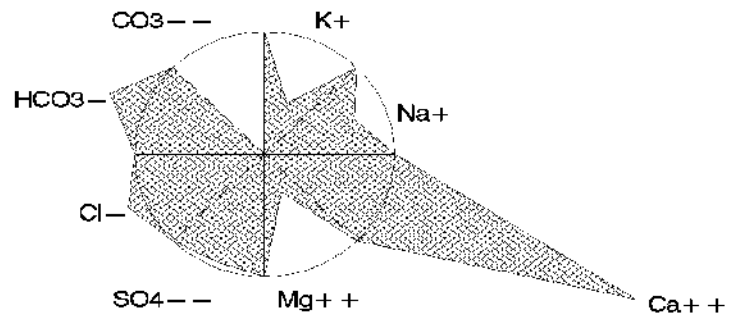

Unnamed Pasco Lake

Pasco County

USGS Quadrangle: Port Richey NE Major Land Use/Land Cover (1990)
 Section/Township/Range: 2-24S-17E within 500 meters of the lakeshore:
 Approx. Lake Center, Lat/Long: 282532/823445 - medium density residential (78%)
 Surface Area: 4 acres - open land (6%)
 Approx. Lake Elevation: 15 feet - low density residential (5%)
 Lake Type: isolated (type 4)
 Major Basin: Upper Coastal Drainage
 Minor Basin: Hammock Creek
 Lake Region: Weeki Wachee Hills

Total Number of Samples Collected: 2 Most Recent Sample Collected: January 1996

Parameter	Units (Detection Limit)	Average Value	District Percentile	Florida Percentile
Chlorophyll a	ug/l (1)	2.7	21	11
Total Phosphorus	mg/l as P (0.01)	0.015	53	8
Total Nitrogen	mg/l as N (0.06)	1.73	76	72
Transparency (Secchi depth)	meters		-	-
Florida Trophic State Index		31	30	6
Specific Conductance	S/cm at 25C (1)	204	61	53
pH	standard units (0.1)	7.6	64	57
Color	PtCo units (1)	8	24	8
Turbidity	NTU (1)	6.6	80	58
Total Alkalinity	mg/l as CaCO3 (1)	90	>95	81
Hardness	mg/l as CaCO3 (0.02)	93	89	
Total Suspended Solids	mg/l (0.05)	6.9	86	
Ammonia	mg/l as N (0.03)	0.112	89	
Nitrate+Nitrite	mg/l as N (0.01)	0.424	90	
Total Kjeldahl Nitrogen	mg/l as N (0.06)	1.30	68	
Orthophosphorus	mg/l as P (0.01)	0.012	68	
Chloride	mg/l (0.05)	6	5	
Sulfate	mg/l (0.05)	6	23	
Sodium	mg/l (0.06)	3.5	5	
Potassium	mg/l (0.07)	0.1	<5	
Calcium	mg/l (0.04)	36.0	>95	
Magnesium	mg/l (0.006)	0.8	<5	
Iron	ug/l (0.03)	56	65	

Based upon the average FTSI of 31, water quality is considered good. Unnamed Pasco Lake can be characterized as a clear (color<=10 color units), medium hard water, oligotrophic lake. The chemical type of water (predominant ionic composition) is calcium bicarbonate.

Plots and Trends: No or insufficient data available for plotting or trend detection. Shown is a diagram of the relative ionic composition of the lake water.

MAJOR IONS (% meq/l)

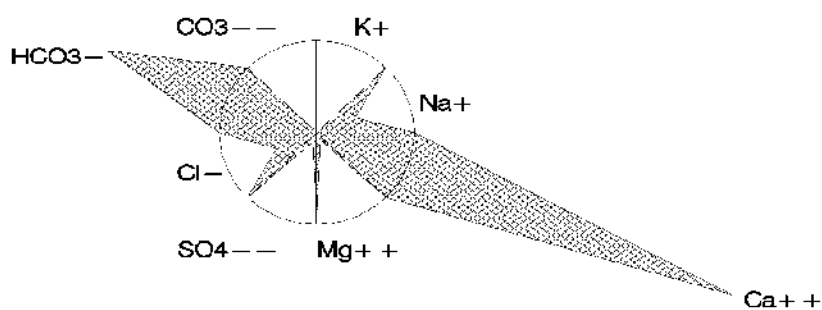

Unnamed Pasco Lake, Pasco County

Vienna Lake

Pasco County

USGS Quadrangle: Lutz Major Land Use/Land Cover (1990)
 Section/Township/Range: 24-26S-18E within 500 meters of the lakeshore:
 Approx. Lake Center, Lat/Long: 281245/822801 - rowcrops (21%)
 Surface Area: 21 acres - tree crops, typically citrus (12%)
 Approx. Lake Elevation: 70 feet - freshwater marshes (10%)
 Lake Type: outflow (type 2)
 Major Basin: Upper Coastal Drainage
 Minor Basin: South Branch
 Lake Region: Land-o-Lakes

Total Number of Samples Collected: 2 Most Recent Sample Collected: January 1995

Parameter	Units (Detection Limit)	Average Value	District Percentile	Florida Percentile
Chlorophyll a	ug/l (1)	3.9	35	16
Total Phosphorus	mg/l as P (0.01)	0.015	53	8
Total Nitrogen	mg/l as N (0.06)	0.48	<5	9
Transparency (Secchi depth)	meters	2.25	70	89
Florida Trophic State Index		31	30	6
Specific Conductance	S/cm at 25C (1)	232	72	57
pH	standard units (0.1)	6.9	29	28
Color	PtCo units (1)	15	46	13
Turbidity	NTU (1)	1.5	41	13
Total Alkalinity	mg/l as CaCO3 (1)	9	24	24
Hardness	mg/l as CaCO3 (0.02)	54	55	
Total Suspended Solids	mg/l (0.05)	1.8	47	
Ammonia	mg/l as N (0.03)	0.015	60	
Nitrate+Nitrite	mg/l as N (0.01)	0.036	62	
Total Kjeldahl Nitrogen	mg/l as N (0.06)	0.46	7	
Orthophosphorus	mg/l as P (0.01)	0.005	56	
Chloride	mg/l (0.05)	32	88	
Sulfate	mg/l (0.05)	37	86	
Sodium	mg/l (0.06)	17.5	89	
Potassium	mg/l (0.07)	6.2	74	
Calcium	mg/l (0.04)	13.5	54	
Magnesium	mg/l (0.006)	4.8	66	
Iron	ug/l (0.03)	21	23	

Based upon the average FTSI of 31, water quality is considered good. Vienna Lake can be characterized as a clear to moderately colored (10<color<20 color units), soft water, oligo-mesotrophic lake, with very low concentrations of total nitrogen. The chemical type of water (predominant ionic composition) is sodium chloride.

Plots and Trends: No or insufficient data available for plotting or trend detection. Shown is a diagram of the relative ionic composition of the lake water.

MAJOR IONS (% meq/l)

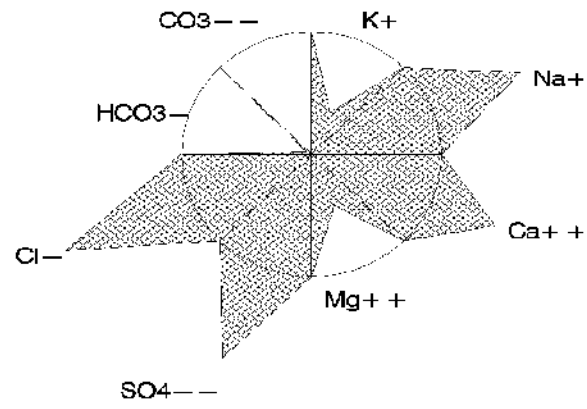

West Moon Lake

Pasco County

USGS Quadrangle: Fivay Junction Major Land Use/Land Cover (1990)
 Section/Township/Range: 29-25S-17E within 500 meters of the lakeshore:
 Approx. Lake Center, Lat/Long: 281715/823722 - hardwood - conifer mixed (30%)
 Surface Area: 53 acres - cypress (14%)
 Approx. Lake Elevation: 33 feet - medium density residential (13%)
 Lake Type: isolated (type 4)
 Major Basin: Upper Coastal Drainage
 Minor Basin: Bear Creek
 Lake Region: Weeki Wachee Hills

Total Number of Samples Collected: 1 Most Recent Sample Collected: July 1994

Parameter	Units (Detection Limit)	Average Value	District Percentile	Florida Percentile
Chlorophyll a	ug/l (1)	3.5	31	14
Total Phosphorus	mg/l as P (0.01)	0.005	31	<5
Total Nitrogen	mg/l as N (0.06)	1.86	82	78
Transparency (Secchi depth)	meters		-	-
Florida Trophic State Index		35	40	9
Specific Conductance	S/cm at 25C (1)	120	20	31
pH	standard units (0.1)	6.9	29	28
Color	PtCo units (1)	15	46	13
Turbidity	NTU (1)	0.5	28	<5
Total Alkalinity	mg/l as CaCO3 (1)	11	29	27
Hardness	mg/l as CaCO3 (0.02)	27	18	
Total Suspended Solids	mg/l (0.05)	1.7	44	
Ammonia	mg/l as N (0.03)	0.015	60	
Nitrate+Nitrite	mg/l as N (0.01)	0.005	33	
Total Kjeldahl Nitrogen	mg/l as N (0.06)	1.86	87	
Orthophosphorus	mg/l as P (0.01)	0.005	56	
Chloride	mg/l (0.05)	15	34	
Sulfate	mg/l (0.05)	11	39	
Sodium	mg/l (0.06)	9.1	53	
Potassium	mg/l (0.07)	0.8	16	
Calcium	mg/l (0.04)	8.2	28	
Magnesium	mg/l (0.006)	1.5	16	
Iron	ug/l (0.03)	0	<5	

Based upon the average FTSI of 35, water quality is considered good. West Moon Lake can be characterized as a clear to moderately colored (10<color<20 color units), soft water, mesotrophic lake, with low concentrations of total phosphorus and high concentrations of total nitrogen. The chemical type of water (predominant ionic composition) is calcium chloride.

Plots and Trends: No or insufficient data available for plotting or trend detection. Shown is a diagram of the relative ionic composition of the lake water.

MAJOR IONS (% meq/l)

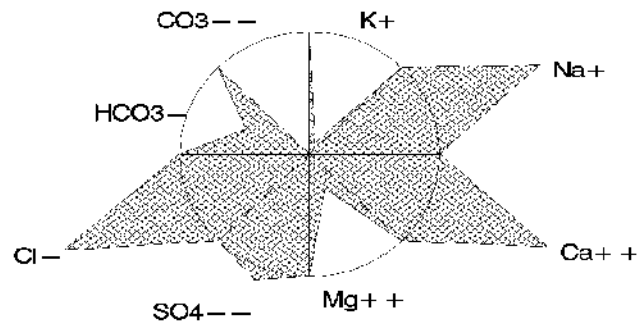

Wistaria Lake Pasco County

USGS Quadrangle: Ehren Major Land Use/Land Cover (1990)
 Section/Township/Range: 2-26S-18E within 500 meters of the lakeshore:
 Approx. Lake Center, Lat/Long: 281504/822838 - low density residential (30%)
 Surface Area: 25 acres - tree crops, typically citrus (20%)
 Approx. Lake Elevation: 74 feet - rowcrops (13%)
 Average Depth: 10.8 feet
 Observed Maximum Depth: 25 feet
 (reference elevation 72.4 feet)
 Lake Type: outflow (type 2)
 Major Basin: Upper Coastal Drainage
 Minor Basin: Anclote River
 Lake Region: Land-o-Lakes

Total Number of Samples Collected: 2 Most Recent Sample Collected: February 1997

Parameter	Units (Detection Limit)	Average Value	District Percentile	Florida Percentile
Chlorophyll a	ug/l (1)	5.6	46	23
Total Phosphorus	mg/l as P (0.01)	0.005	31	<5
Total Nitrogen	mg/l as N (0.06)	0.99	40	33
Transparency (Secchi depth)	meters	2.27	71	90
Florida Trophic State Index		30	28	5
Specific Conductance	S/cm at 25C (1)	176	48	47
pH	standard units (0.1)	7.7	69	60
Color	PtCo units (1)	18	51	15
Turbidity	NTU (1)	2.2	54	23
Total Alkalinity	mg/l as CaCO3 (1)	31	60	50
Hardness	mg/l as CaCO3 (0.02)	51	53	
Total Suspended Solids	mg/l (0.05)	2.5	59	
Ammonia	mg/l as N (0.03)	0.015	60	
Nitrate+Nitrite	mg/l as N (0.01)	0.005	33	
Total Kjeldahl Nitrogen	mg/l as N (0.06)	0.99	47	
Orthophosphorus	mg/l as P (0.01)	0.005	56	
Chloride	mg/l (0.05)	21	61	
Sulfate	mg/l (0.05)	21	63	
Sodium	mg/l (0.06)	9.0	52	
Potassium	mg/l (0.07)	6.9	81	
Calcium	mg/l (0.04)	12.2	50	
Magnesium	mg/l (0.006)	4.9	68	
Iron	ug/l (0.03)	28	34	

Based upon the average FTSI of 30, water quality is considered good. Wistaria Lake can be characterized as a clear to moderately colored (10<color<20 color units), soft water, meso-eutrophic lake, with low concentrations of total phosphorus. The chemical type of water (predominant ionic composition) is calcium chloride.

Plots and Trends: No or insufficient data available for plotting or trend detection. Shown is a diagram of the relative ionic composition of the lake water.

MAJOR IONS (% meq/l)

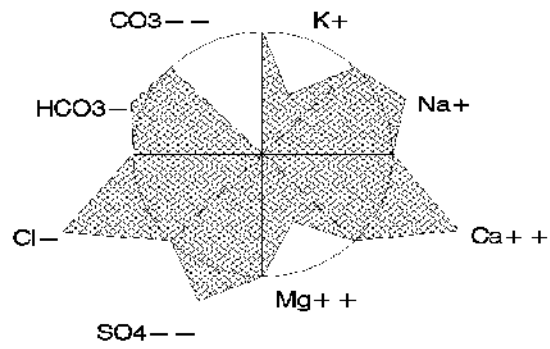

Wistaria Lake, Pasco County

Lake Worrell

Pasco County

USGS Quadrangle: Port Richey Major Land Use/Land Cover (1990)
 Section/Township/Range: 26-25S-16E within 500 meters of the lakeshore:
 Approx. Lake Center, Lat/Long: 281701/824006 - low density residential (33%)
 Surface Area: 22 acres - medium density residential (23%)
 Approx. Lake Elevation: 19 feet - wetland forested mixed (9%)
 Lake Type: inflow and outflow (type 3)
 Major Basin: Upper Coastal Drainage
 Minor Basin: Double Hammock Creek
 Lake Region: Tampa Plain

Total Number of Samples Collected: 2 Most Recent Sample Collected: January 1995

Parameter	Units (Detection Limit)	Average Value	District Percentile	Florida Percentile
Chlorophyll a	ug/l (1)	2.9	23	12
Total Phosphorus	mg/l as P (0.01)	0.024	71	14
Total Nitrogen	mg/l as N (0.06)	1.63	73	67
Transparency (Secchi depth)	meters	1.00	35	63
Florida Trophic State Index		46	64	27
Specific Conductance	S/cm at 25C (1)	230	70	57
pH	standard units (0.1)	7.4	57	50
Color	PtCo units (1)	188	>95	>95
Turbidity	NTU (1)	1.3	36	10
Total Alkalinity	mg/l as CaCO3 (1)	58	86	67
Hardness	mg/l as CaCO3 (0.02)	89	86	
Total Suspended Solids	mg/l (0.05)	1.4	37	
Ammonia	mg/l as N (0.03)	0.026	60	
Nitrate+Nitrite	mg/l as N (0.01)	0.013	41	
Total Kjeldahl Nitrogen	mg/l as N (0.06)	1.61	80	
Orthophosphorus	mg/l as P (0.01)	0.018	84	
Chloride	mg/l (0.05)	26	78	
Sulfate	mg/l (0.05)	5	20	
Sodium	mg/l (0.06)	13.0	76	
Potassium	mg/l (0.07)	0.5	11	
Calcium	mg/l (0.04)	32.5	94	
Magnesium	mg/l (0.006)	2.0	25	
Iron	ug/l (0.03)	295	>95	

Based upon the average FTSI of 46, water quality is considered good. Lake Worrell can be characterized as a highly colored, medium hard water, oligo-mesotrophic lake. The chemical type of water (predominant ionic composition) is calcium chloride.

Plots and Trends: No or insufficient data available for plotting or trend detection. Shown is a diagram of the relative ionic composition of the lake water.

MAJOR IONS (% meq/l)

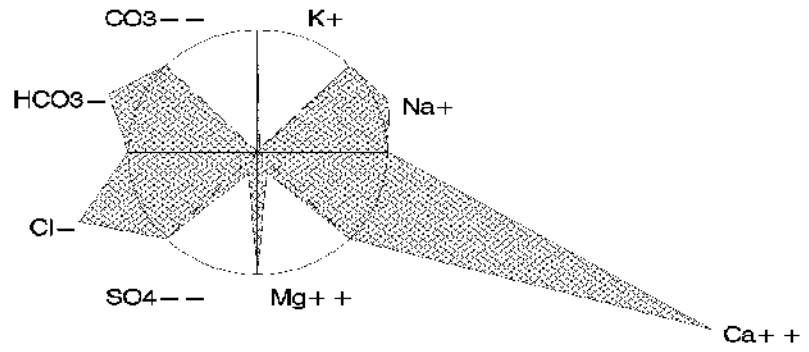

Alligator Lake

Pinellas County

USGS Quadrangle: Safety Harbor Major Land Use/Land Cover (1990)
 Section/Township/Range: 9-29S-16E within 500 meters of the lakeshore:
 Approx. Lake Center, Lat/Long: 275852/824154 - high density residential (44%)
 Surface Area: 77 acres - medium density residential (13%)
 Approx. Lake Elevation: 5 feet - commercial and services (13%)
 Lake Type: inflow and outflow (type 3)
 Major Basin: Tampa Bay Drainage
 Minor Basin: Alligator Creek
 Lake Region: Pinellas Peninsula
 Public Access: yes

Total Number of Samples Collected: 2 Most Recent Sample Collected: February 1997

Parameter	Units (Detection Limit)	Average Value	District Percentile	Florida Percentile
Chlorophyll a	ug/l (1)	32.2	86	67
Total Phosphorus	mg/l as P (0.01)	0.117	95	72
Total Nitrogen	mg/l as N (0.06)	0.87	30	29
Transparency (Secchi depth)	meters	1.05	36	65
Florida Trophic State Index		57	81	48
Specific Conductance	S/cm at 25C (1)	370	94	74
pH	standard units (0.1)	7.9	78	67
Color	PtCo units (1)	25	62	20
Turbidity	NTU (1)	3.2	64	34
Total Alkalinity	mg/l as CaCO3 (1)	98	>95	85
Hardness	mg/l as CaCO3 (0.02)	120	95	
Total Suspended Solids	mg/l (0.05)	3.4	66	
Ammonia	mg/l as N (0.03)	0.015	60	
Nitrate+Nitrite	mg/l as N (0.01)	0.011	37	
Total Kjeldahl Nitrogen	mg/l as N (0.06)	0.86	36	
Orthophosphorus	mg/l as P (0.01)	0.085	>95	
Chloride	mg/l (0.05)	45	>95	
Sulfate	mg/l (0.05)	17	54	
Sodium	mg/l (0.06)	24.5	>95	
Potassium	mg/l (0.07)	3.6	50	
Calcium	mg/l (0.04)	40.5	>95	
Magnesium	mg/l (0.006)	4.6	65	
Iron	ug/l (0.03)	73	72	

Based upon the average FTSI of 57, water quality is considered good. Alligator Lake can be characterized as a moderately colored, medium hard water, eutrophic to hypereutrophic lake, with high concentrations of total phosphorus. The chemical type of water (predominant ionic composition) is calcium chloride (1 sample) or calcium bicarbonate (1 sample).

Plots and Trends: Due to the high variability in the plotted concentrations, as well as the sporadic sampling intervals, no trends are evident. Also shown is a diagram of the relative ionic composition of the lake water.

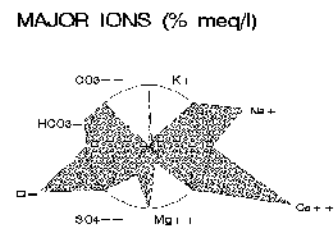
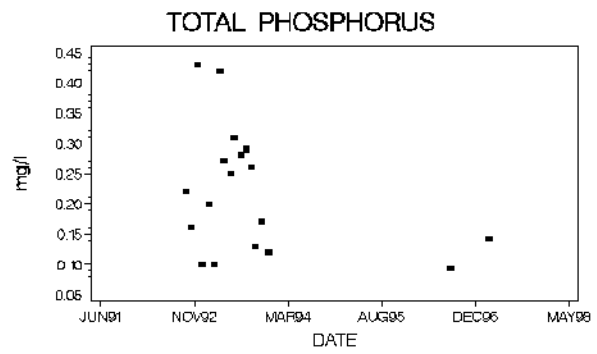
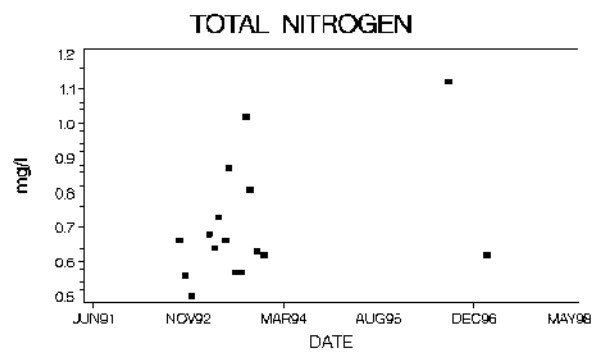
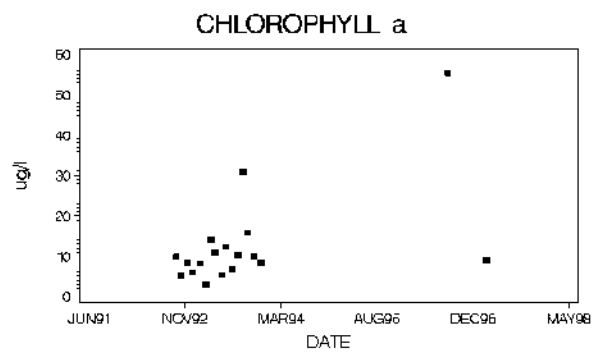
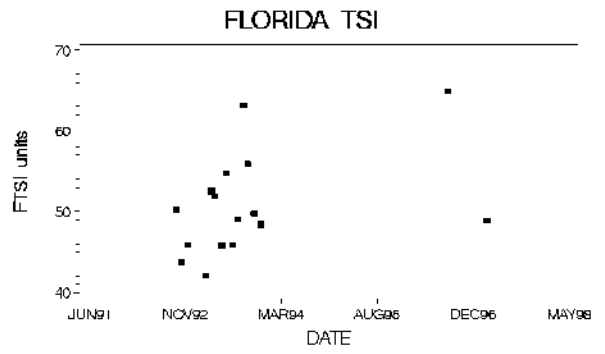
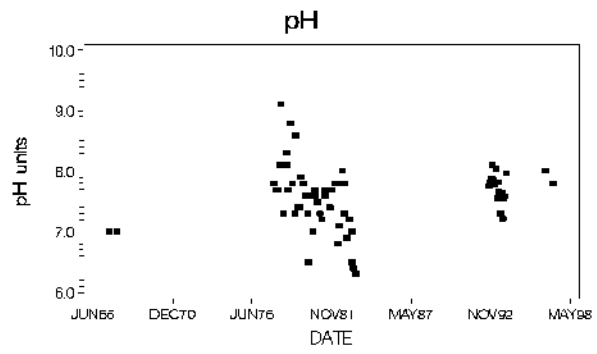
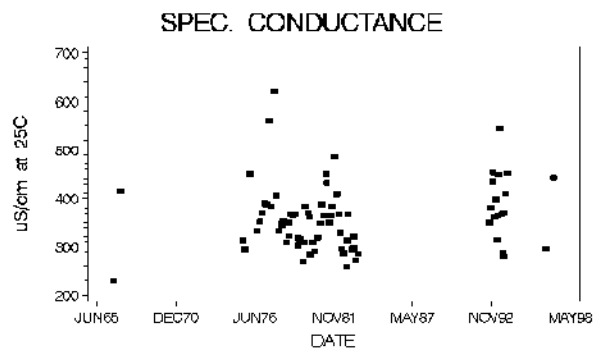
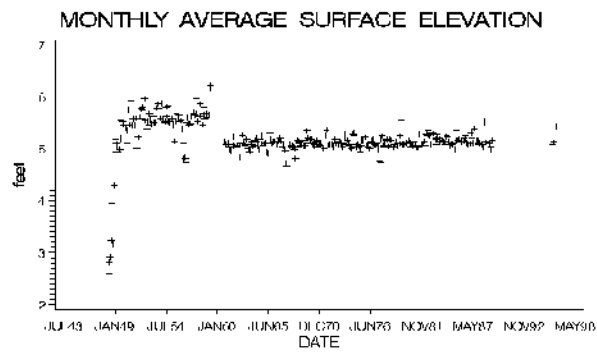

Alligator Lake, Pinellas County

Beckett Lake

Pinellas County

USGS Quadrangle:	Safety Harbor	Major Land Use/Land Cover (1990)
Section/Township/Range:	6-29S-16E	within 500 meters of the lakeshore:
Approx. Lake Center, Lat/Long:	275927/824447	- high density residential (57%)
Surface Area:	16 acres	- industrial (12%)
Approx. Lake Elevation:	52 feet	- commercial and services (7%)
Lake Type:	isolated (type 4)	
Major Basin:	Tampa Bay Drainage	
Minor Basin:	Alligator Creek	
Lake Region:	Pinellas Peninsula	

Total Number of Samples Collected: 2 Most Recent Sample Collected: February 1997

Parameter	Units (Detection Limit)	Average Value	District Percentile	Florida Percentile
Chlorophyll a	ug/l (1)	37.1	89	72
Total Phosphorus	mg/l as P (0.01)	0.056	88	43
Total Nitrogen	mg/l as N (0.06)	1.16	52	39
Transparency (Secchi depth)	meters	0.83	25	53
Florida Trophic State Index		65	90	66
Specific Conductance	S/cm at 25C (1)	316	90	71
pH	standard units (0.1)	7.8	74	63
Color	PtCo units (1)	10	34	10
Turbidity	NTU (1)	6.2	79	56
Total Alkalinity	mg/l as CaCO3 (1)	72	93	73
Hardness	mg/l as CaCO3 (0.02)	105	92	
Total Suspended Solids	mg/l (0.05)	6.9	86	
Ammonia	mg/l as N (0.03)	0.015	60	
Nitrate+Nitrite	mg/l as N (0.01)	0.005	33	
Total Kjeldahl Nitrogen	mg/l as N (0.06)	1.16	59	
Orthophosphorus	mg/l as P (0.01)	0.011	64	
Chloride	mg/l (0.05)	34	90	
Sulfate	mg/l (0.05)	30	77	
Sodium	mg/l (0.06)	17.5	89	
Potassium	mg/l (0.07)	6.1	73	
Calcium	mg/l (0.04)	36.0	>95	
Magnesium	mg/l (0.006)	3.7	55	
Iron	ug/l (0.03)	281	95	

Based upon the average FTSI of 65, water quality is considered fair. Beckett Lake can be characterized as a clear (color<=10 color units), medium hard water, eutrophic to hypereutrophic lake, with high concentrations of total phosphorus. The chemical type of water (predominant ionic composition) is calcium chloride.

Also of note:

- Cattails dominate more than 30% of the lake shoreline.

Plots and Trends: No or insufficient data for plotting or trend detection. Shown is a diagram of the relative ionic composition of the lake water.

MAJOR IONS (% meq/l)

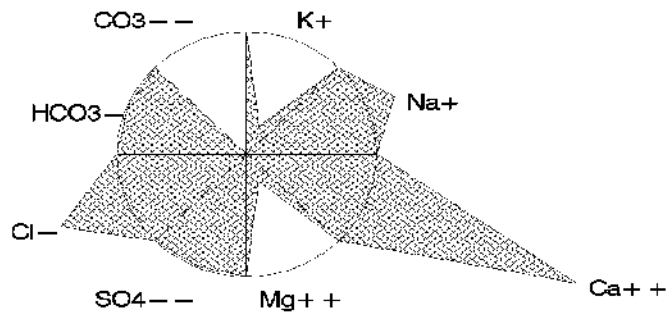

Bellevue Lake

Pinellas County

USGS Quadrangle: Clearwater Major Land Use/Land Cover (1990)
 Section/Township/Range: 22-29S-15E within 500 meters of the lakeshore:
 Approx. Lake Center, Lat/Long: 275649/824739 - high density residential (46%)
 Surface Area: 23 acres - commercial and services (27%)
 Approx. Lake Elevation: 38 feet - recreational (7%)
 Lake Type: outflow (type 2)
 Major Basin: Upper Coastal Drainage
 Minor Basin: Stevenson Creek
 Lake Region: Pinellas Peninsula
 Public Access: yes

Total Number of Samples Collected: 2 Most Recent Sample Collected: February 1997

Parameter	Units (Detection Limit)	Average Value	District Percentile	Florida Percentile
Chlorophyll a	ug/l (1)	40.1	91	75
Total Phosphorus	mg/l as P (0.01)	0.058	89	44
Total Nitrogen	mg/l as N (0.06)	1.27	59	44
Transparency (Secchi depth)	meters	0.64	17	34
Florida Trophic State Index		68	93	75
Specific Conductance	S/cm at 25C (1)	265	82	63
pH	standard units (0.1)	8.4	90	80
Color	PtCo units (1)	15	46	13
Turbidity	NTU (1)	8.8	85	66
Total Alkalinity	mg/l as CaCO3 (1)	91	>95	82
Hardness	mg/l as CaCO3 (0.02)	106	92	
Total Suspended Solids	mg/l (0.05)	12.3	93	
Ammonia	mg/l as N (0.03)	0.015	60	
Nitrate+Nitrite	mg/l as N (0.01)	0.005	33	
Total Kjeldahl Nitrogen	mg/l as N (0.06)	1.27	66	
Orthophosphorus	mg/l as P (0.01)	0.015	80	
Chloride	mg/l (0.05)	19	51	
Sulfate	mg/l (0.05)	15	50	
Sodium	mg/l (0.06)	11.5	66	
Potassium	mg/l (0.07)	2.5	41	
Calcium	mg/l (0.04)	39.0	>95	
Magnesium	mg/l (0.006)	2.2	31	
Iron	ug/l (0.03)	36	48	

Based upon the average FTSI of 68, water quality is considered fair. Bellevue Lake can be characterized as a clear to moderately colored (color<=20 color units), medium hard water, eutrophic to hypereutrophic lake, with high concentrations of total phosphorus. The chemical type of water (predominant ionic composition) is calcium bicarbonate.

Also of note:

- The measured pH was high.
- Waterhyacinth was observed in the lake.

Plots and Trends: No or insufficient data for plotting or trend detection. Shown is a diagram of the relative ionic composition of the lake water.

MAJOR IONS (% meq/l)

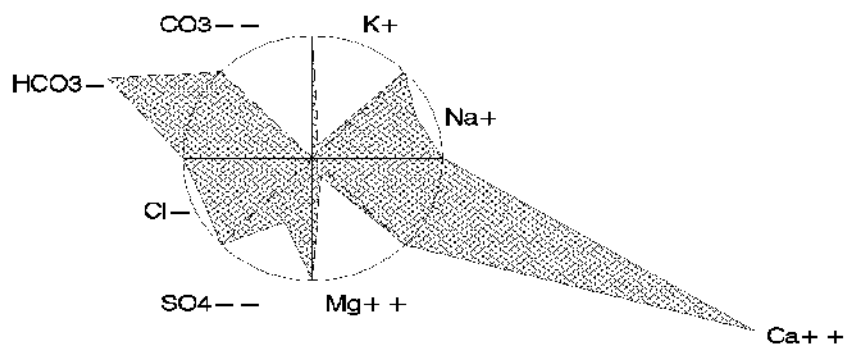

Lake Bowden (Chautauqua) Pinellas County

USGS Quadrangle:	Oldsmar	Major Land Use/Land Cover (1990)
Section/Township/Range:	32-28S-16E	within 500 meters of the lakeshore:
Approx. Lake Center, Lat/Long:	280016/824323	- high density residential (19%)
Surface Area:	91 acres	- low density residential (15%)
Approx. Lake Elevation:	83 feet	- pine flatwoods (13%)
Lake Type:	inflow (type 1)	
Major Basin:	Tampa Bay Drainage	
Minor Basin:	Alligator Creek	
Lake Region:	Pinellas Peninsula	

Total Number of Samples Collected: 2 Most Recent Sample Collected: February 1997

Parameter	Units (Detection Limit)	Average Value	District Percentile	Florida Percentile
Chlorophyll a	ug/l (1)	2.7	21	11
Total Phosphorus	mg/l as P (0.01)	0.008	31	<5
Total Nitrogen	mg/l as N (0.06)	0.67	16	19
Transparency (Secchi depth)	meters		-	-
Florida Trophic State Index		29	25	<5
Specific Conductance	S/cm at 25C (1)	224	68	56
pH	standard units (0.1)	7.8	74	63
Color	PtCo units (1)	20	55	17
Turbidity	NTU (1)	0.5	28	<5
Total Alkalinity	mg/l as CaCO3 (1)	52	81	63
Hardness	mg/l as CaCO3 (0.02)	68	71	
Total Suspended Solids	mg/l (0.05)	0.3	<5	
Ammonia	mg/l as N (0.03)	0.015	60	
Nitrate+Nitrite	mg/l as N (0.01)	0.005	33	
Total Kjeldahl Nitrogen	mg/l as N (0.06)	0.67	22	
Orthophosphorus	mg/l as P (0.01)	0.005	56	
Chloride	mg/l (0.05)	34	90	
Sulfate	mg/l (0.05)	7	27	
Sodium	mg/l (0.06)	16.0	86	
Potassium	mg/l (0.07)	1.7	28	
Calcium	mg/l (0.04)	23.0	84	
Magnesium	mg/l (0.006)	2.6	38	
Iron	ug/l (0.03)	52	62	

Based upon the average FTSI of 29, water quality is considered good. Lake Bowden (Chautauqua) can be characterized as a moderately colored, medium hard water, oligo-mesotrophic lake, with low concentrations of total phosphorus and total nitrogen. The chemical type of water (predominant ionic composition) is calcium chloride.

Also of note:

- Hydrilla was observed in the lake.

Plots and Trends: There are no trends evident in the data shown in the plots. The much greater concentrations of total phosphorus shown for samples collected between 1990 and 1993 reflect the laboratory limit of detection (0.05 mg/l). Also shown is a diagram of the relative ionic composition of the lake water.

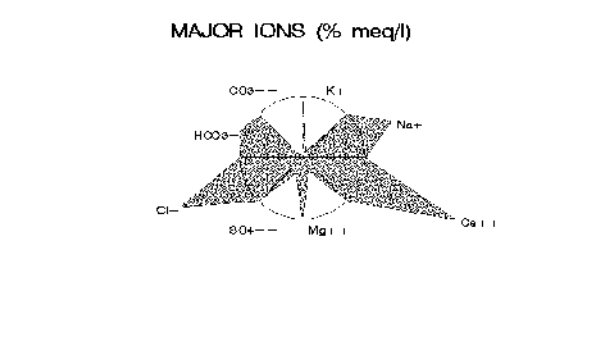
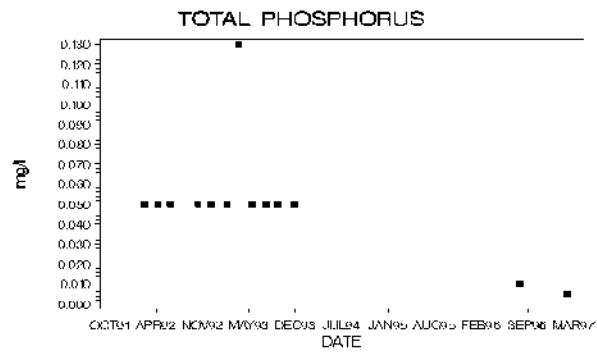
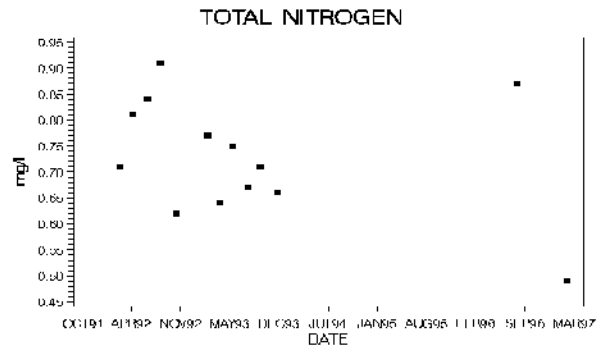
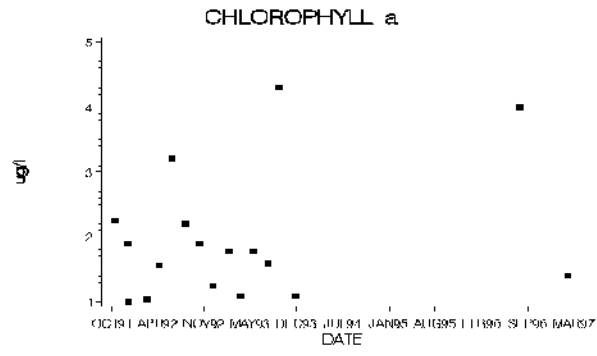
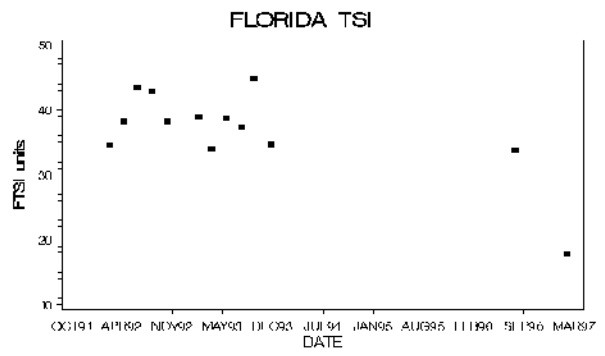
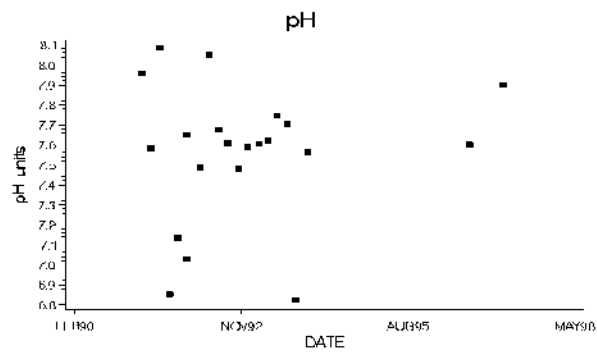

Lake Bowden (Chautauqua), Pinellas County

Crescent Lake

Pinellas County

USGS Quadrangle: St Petersburg Major Land Use/Land Cover (1990)
 Section/Township/Range: 18-31S-17E within 500 meters of the lakeshore:
 Approx. Lake Center, Lat/Long: 274717/823830 - high density residential (69%)
 Surface Area: 20 acres - commercial and services (18%)
 Approx. Lake Elevation: 21 feet - recreational (9%)
 Lake Type: inflow and outflow (type 3)
 Major Basin: Tampa Bay Drainage
 Minor Basin: Coffeepot Bayou
 Lake Region: Pinellas Peninsula
 Public Access: yes

Total Number of Samples Collected: 2 Most Recent Sample Collected: February 1997

Parameter	Units (Detection Limit)	Average Value	District Percentile	Florida Percentile
Chlorophyll a	ug/l (1)	54.6	95	84
Total Phosphorus	mg/l as P (0.01)	0.128	>95	75
Total Nitrogen	mg/l as N (0.06)	0.78	26	24
Transparency (Secchi depth)	meters	1.24	41	71
Florida Trophic State Index		68	93	75
Specific Conductance	S/cm at 25C (1)	297	88	69
pH	standard units (0.1)	8.7	93	88
Color	PtCo units (1)	25	62	20
Turbidity	NTU (1)	4.5	72	46
Total Alkalinity	mg/l as CaCO3 (1)	78	94	76
Hardness	mg/l as CaCO3 (0.02)	101	91	
Total Suspended Solids	mg/l (0.05)	4.0	73	
Ammonia	mg/l as N (0.03)	0.015	60	
Nitrate+Nitrite	mg/l as N (0.01)	0.048	68	
Total Kjeldahl Nitrogen	mg/l as N (0.06)	0.73	27	
Orthophosphorus	mg/l as P (0.01)	0.057	95	
Chloride	mg/l (0.05)	37	94	
Sulfate	mg/l (0.05)	16	52	
Sodium	mg/l (0.06)	19.0	91	
Potassium	mg/l (0.07)	2.6	42	
Calcium	mg/l (0.04)	36.0	>95	
Magnesium	mg/l (0.006)	2.7	40	
Iron	ug/l (0.03)	86	78	

Based upon the average FTSI of 68, water quality is considered fair. Crescent Lake can be characterized as a moderately colored, medium hard water, eutrophic to hypereutrophic lake, with high concentrations of total phosphorus. The chemical type of water (predominant ionic composition) is calcium chloride.

Also of note:

- The measured pH was high.

Plots and Trends: No or insufficient data for plotting or trend detection. Shown is a diagram of the relative ionic composition of the lake water.

MAJOR IONS (% meq/l)

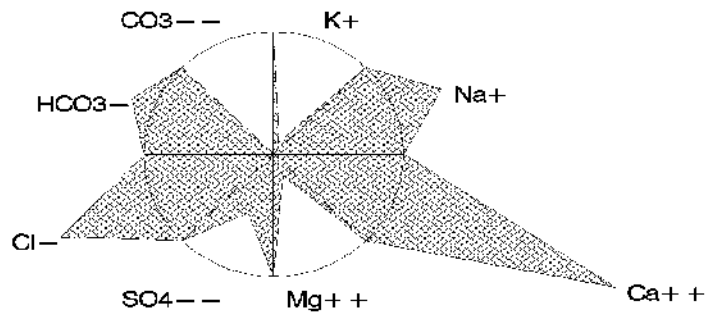

Crest (Excelsior) Lake

Pinellas County

USGS Quadrangle: Clearwater
 Section/Township/Range: 14-29S-15E
 Approx. Lake Center, Lat/Long: 275745/824620
 Surface Area: 13 acres
 Approx. Lake Elevation: 68 feet
 Lake Type: inflow and outflow (type 3)
 Major Basin: Tampa Bay Drainage
 Minor Basin: Allen Creek
 Lake Region: Pinellas Peninsula
 Public Access: yes

Major Land Use/Land Cover (1990)
 within 500 meters of the lakeshore:
 - high density residential (69%)
 - commercial and services (17%)
 - recreational (11%)

Total Number of Samples Collected: 2 Most Recent Sample Collected: February 1997

Parameter	Units (Detection Limit)	Average Value	District Percentile	Florida Percentile
Chlorophyll a	ug/l (1)	3.2	27	13
Total Phosphorus	mg/l as P (0.01)	0.013	46	7
Total Nitrogen	mg/l as N (0.06)	0.65	15	18
Transparency (Secchi depth)	meters	3.00	84	>95
Florida Trophic State Index		31	33	6
Specific Conductance	S/cm at 25C (1)	144	33	40
pH	standard units (0.1)	7.3	50	45
Color	PtCo units (1)	5	9	5
Turbidity	NTU (1)	1.3	36	10
Total Alkalinity	mg/l as CaCO3 (1)	12	31	29
Hardness	mg/l as CaCO3 (0.02)	38	32	
Total Suspended Solids	mg/l (0.05)	0.8	21	
Ammonia	mg/l as N (0.03)	0.015	60	
Nitrate+Nitrite	mg/l as N (0.01)	0.005	33	
Total Kjeldahl Nitrogen	mg/l as N (0.06)	0.65	20	
Orthophosphorus	mg/l as P (0.01)	0.005	56	
Chloride	mg/l (0.05)	20	56	
Sulfate	mg/l (0.05)	22	65	
Sodium	mg/l (0.06)	10.5	62	
Potassium	mg/l (0.07)	1.6	27	
Calcium	mg/l (0.04)	12.5	51	
Magnesium	mg/l (0.006)	1.6	18	
Iron	ug/l (0.03)	24	29	

Based upon the average FTSI of 31, water quality is considered good. Crest (Excelsior) Lake can be characterized as a clear (color<=10 color units), soft water, oligo-mesotrophic lake, with low concentrations of total nitrogen. The chemical type of water (predominant ionic composition) is calcium chloride.

Plots and Trends: No or insufficient data for plotting or trend detection. Shown is a diagram of the relative ionic composition of the lake water.

MAJOR IONS (% meq/l)

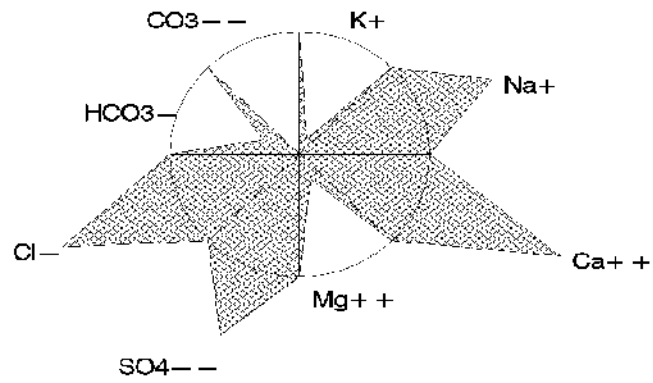

Crest (Excelsior) Lake, Pinellas County

Freedom Lake

Pinellas County

USGS Quadrangle: St Petersburg Major Land Use/Land Cover (1990)
 Section/Township/Range: 21-30S-16E within 500 meters of the lakeshore:
 Approx. Lake Center, Lat/Long: 275144/824153 - high density residential (61%)
 Surface Area: 9 acres - transportation (14%)
 Approx. Lake Elevation: 12 feet - commercial and services (12%)
 Lake Type: inflow and outflow (type 3)
 Major Basin: Tampa Bay Drainage
 Minor Basin: Grande Bayou
 Lake Region: Pinellas Peninsula
 Public Access: yes

Total Number of Samples Collected: 2 Most Recent Sample Collected: February 1997

Parameter	Units (Detection Limit)	Average Value	District Percentile	Florida Percentile
Chlorophyll a	ug/l (1)	6.3	51	27
Total Phosphorus	mg/l as P (0.01)	0.079	92	59
Total Nitrogen	mg/l as N (0.06)	1.10	48	37
Transparency (Secchi depth)	meters	1.28	44	72
Florida Trophic State Index		44	62	23
Specific Conductance	S/cm at 25C (1)	282	85	66
pH	standard units (0.1)	7.6	64	57
Color	PtCo units (1)	40	72	30
Turbidity	NTU (1)	3.8	69	40
Total Alkalinity	mg/l as CaCO3 (1)	61	86	68
Hardness	mg/l as CaCO3 (0.02)	91	87	
Total Suspended Solids	mg/l (0.05)	2.4	57	
Ammonia	mg/l as N (0.03)	0.117	90	
Nitrate+Nitrite	mg/l as N (0.01)	0.079	79	
Total Kjeldahl Nitrogen	mg/l as N (0.06)	1.03	50	
Orthophosphorus	mg/l as P (0.01)	0.037	92	
Chloride	mg/l (0.05)	36	93	
Sulfate	mg/l (0.05)	20	61	
Sodium	mg/l (0.06)	18.5	90	
Potassium	mg/l (0.07)	2.8	45	
Calcium	mg/l (0.04)	29.0	91	
Magnesium	mg/l (0.006)	4.5	63	
Iron	ug/l (0.03)	160	89	

Based upon the average FTSI of 44, water quality is considered good. Freedom Lake is a constructed stormwater treatment pond, for treating the runoff from US 19 and a surrounding area. Freedom Lake can be characterized as a colored, medium hard water, meso-eutrophic lake, with high concentrations of total phosphorus. The chemical type of water (predominant ionic composition) is calcium chloride.

Plots and Trends: No or insufficient data available for plotting or trend detection. Shown is a diagram of the relative ionic composition of the lake water.

MAJOR IONS (% meq/l)

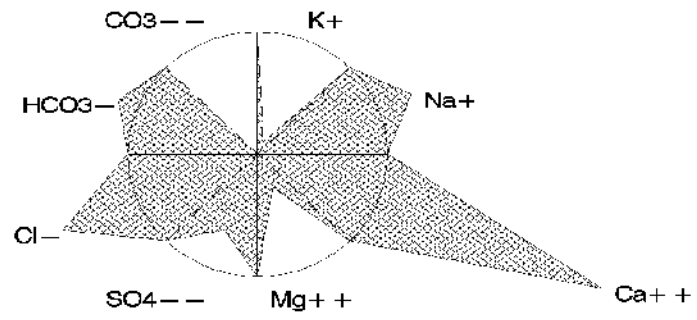

Harbor Lake

Pinellas County

USGS Quadrangle: Safety Harbor Major Land Use/Land Cover (1990)
 Section/Township/Range: 36-28S-15E within 500 meters of the lakeshore:
 Approx. Lake Center, Lat/Long: 275948/824453 - high density residential (75%)
 Surface Area: 39 acres - other open lands - rural (4%)
 Approx. Lake Elevation: 57 feet - low density residential (4%)
 Lake Type: isolated (type 4)
 Major Basin: Tampa Bay Drainage
 Minor Basin: Alligator Creek
 Lake Region: Pinellas Peninsula

Total Number of Samples Collected: 2 Most Recent Sample Collected: February 1997

Parameter	Units (Detection Limit)	Average Value	District Percentile	Florida Percentile
Chlorophyll a	ug/l (1)	7.6	55	32
Total Phosphorus	mg/l as P (0.01)	0.014	50	7
Total Nitrogen	mg/l as N (0.06)	0.94	36	31
Transparency (Secchi depth)	meters	2.92	82	>95
Florida Trophic State Index		37	47	12
Specific Conductance	S/cm at 25C (1)	256	79	61
pH	standard units (0.1)	7.7	69	60
Color	PtCo units (1)	13	41	12
Turbidity	NTU (1)	1.1	32	7
Total Alkalinity	mg/l as CaCO3 (1)	70	92	73
Hardness	mg/l as CaCO3 (0.02)	91	87	
Total Suspended Solids	mg/l (0.05)	0.5	11	
Ammonia	mg/l as N (0.03)	0.015	60	
Nitrate+Nitrite	mg/l as N (0.01)	0.011	37	
Total Kjeldahl Nitrogen	mg/l as N (0.06)	0.93	41	
Orthophosphorus	mg/l as P (0.01)	0.005	56	
Chloride	mg/l (0.05)	20	56	
Sulfate	mg/l (0.05)	24	69	
Sodium	mg/l (0.06)	13.0	76	
Potassium	mg/l (0.07)	4.2	58	
Calcium	mg/l (0.04)	32.5	94	
Magnesium	mg/l (0.006)	2.4	35	
Iron	ug/l (0.03)	15	10	

Based upon the average FTSI of 37, water quality is considered good. Harbor Lake can be characterized as a clear to moderately colored (10<color<20 color units), medium hard water, meso-eutrophic lake. The chemical type of water (predominant ionic composition) is calcium bicarbonate.

Also of note:

- Cattails dominate more than 30% of the lake shoreline.

Plots and Trends: No or insufficient data available for plotting or trend detection. Shown is a diagram of the relative ionic composition of the lake water.

MAJOR IONS (% meq/l)

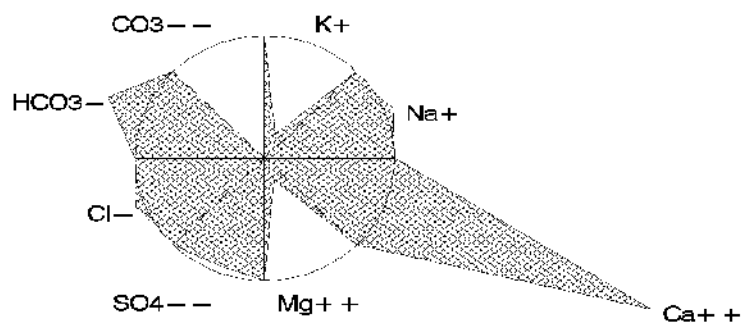

Lake Maggiore

Pinellas County

USGS Quadrangle: Pass-a-Grille Beach Major Land Use/Land Cover (1990)
 Section/Township/Range: 36-31S-16E within 500 meters of the lakeshore:
 Approx. Lake Center, Lat/Long: 274414/823914 - high density residential (49%)
 Surface Area: 380 acres - pine flatwoods (12%)
 Approx. Lake Elevation: 4 feet - recreational (11%)
 Average Depth: 4.4 feet
 (reference elevation not given)
 Lake Type: inflow and outflow (type 3)
 Major Basin: Tampa Bay Drainage
 Minor Basin: Salt Creek
 Lake Region: Pinellas Peninsula
 Public Access: yes

Total Number of Samples Collected: 8 Most Recent Sample Collected: March 1994

Parameter	Units (Detection Limit)	Average Value	District Percentile	Florida Percentile
Chlorophyll a	ug/l (1)	78.6	>95	92
Total Phosphorus	mg/l as P (0.01)	0.181	>95	82
Total Nitrogen	mg/l as N (0.06)	2.28	89	85
Transparency (Secchi depth)	meters	0.63	16	33
Florida Trophic State Index		56	80	46
Specific Conductance	S/cm at 25C (1)	6645	>95	>95
pH	standard units (0.1)	8.0	81	70
Color	PtCo units (1)	29	66	23
Turbidity	NTU (1)	13.3	92	74
Total Alkalinity	mg/l as CaCO3 (1)	107	>95	90
Hardness	mg/l as CaCO3 (0.02)	865	>95	
Total Suspended Solids	mg/l (0.05)	17.5	>95	
Ammonia	mg/l as N (0.03)	0.070	82	
Nitrate+Nitrite	mg/l as N (0.01)	0.014	42	
Total Kjeldahl Nitrogen	mg/l as N (0.06)	2.28	95	
Orthophosphorus	mg/l as P (0.01)	0.049	93	
Chloride	mg/l (0.05)	1695	>95	
Sulfate	mg/l (0.05)	0	<5	
Sodium	mg/l (0.06)	833.1	>95	
Potassium	mg/l (0.07)	37.0	>95	
Calcium	mg/l (0.04)	116.6	>95	
Magnesium	mg/l (0.006)	106.9	>95	
Iron	ug/l (0.03)	98	81	

Based upon the average FTSI of 56, water quality is considered poor. Lake Maggiore can be characterized as a moderately colored, very hard water, hypereutrophic lake, with high concentrations of total phosphorus and high concentrations of total nitrogen.

Also of note:

- The measured pH was high.

Plots and Trends: No plots are shown for Lake Maggiore. Lake Maggiore has been the subject of intensive study through the 1980s and the 1990s, and management efforts are underway to improve water quality in the lake, including sediment removal (dredging), stormwater retrofit, and other nutrient load reduction strategies.

Mirror Lake

Pinellas County

USGS Quadrangle: St Petersburg Major Land Use/Land Cover (1990)
 Section/Township/Range: 19-31S-17E within 500 meters of the lakeshore:
 Approx. Lake Center, Lat/Long: 274627/823833 - commercial and services (47%)
 Surface Area: 12 acres - high density residential (33%)
 Approx. Lake Elevation: 28 feet - institutional (8%)
 Lake Type: isolated (type 4)
 Major Basin: Tampa Bay Drainage
 Minor Basin: Direct Runoff To Bay
 Lake Region: Pinellas Peninsula
 Public Access: yes

Total Number of Samples Collected: 2 Most Recent Sample Collected: February 1997

Parameter	Units (Detection Limit)	Average Value	District Percentile	Florida Percentile
Chlorophyll a	ug/l (1)	19.1	79	51
Total Phosphorus	mg/l as P (0.01)	0.034	80	24
Total Nitrogen	mg/l as N (0.06)	0.75	23	23
Transparency (Secchi depth)	meters	1.09	38	66
Florida Trophic State Index		56	80	47
Specific Conductance	S/cm at 25C (1)	202	60	52
pH	standard units (0.1)	8.4	90	80
Color	PtCo units (1)	8	24	8
Turbidity	NTU (1)	4.7	73	48
Total Alkalinity	mg/l as CaCO3 (1)	72	93	73
Hardness	mg/l as CaCO3 (0.02)	81	80	
Total Suspended Solids	mg/l (0.05)	5.5	80	
Ammonia	mg/l as N (0.03)	0.015	60	
Nitrate+Nitrite	mg/l as N (0.01)	0.005	33	
Total Kjeldahl Nitrogen	mg/l as N (0.06)	0.75	30	
Orthophosphorus	mg/l as P (0.01)	0.010	59	
Chloride	mg/l (0.05)	14	30	
Sulfate	mg/l (0.05)	8	31	
Sodium	mg/l (0.06)	8.6	49	
Potassium	mg/l (0.07)	1.7	28	
Calcium	mg/l (0.04)	29.5	92	
Magnesium	mg/l (0.006)	1.8	22	
Iron	ug/l (0.03)	51	61	

Based upon the average FTSI of 56, water quality is considered good. Mirror Lake can be characterized as a clear (color<=10 color units), medium hard water, eutrophic lake, with high concentrations of total phosphorus. The chemical type of water (predominant ionic composition) is calcium bicarbonate.

Also of note:

- The measured pH was high.

Plots and Trends: Shown is a diagram of the relative ionic composition of the lake water.

MAJOR IONS (% meq/l)

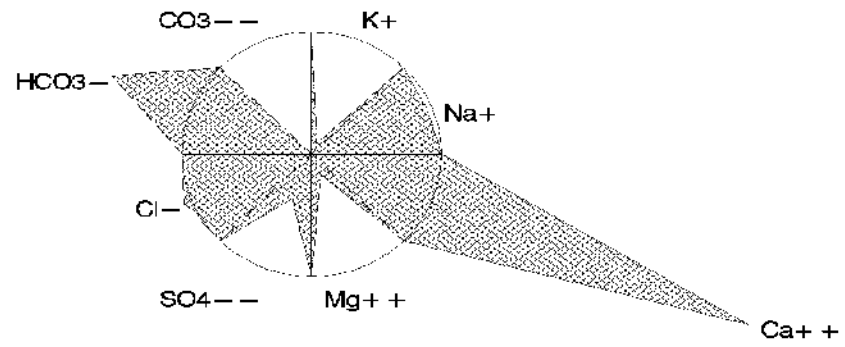

Pasadena Lake

Pinellas County

USGS Quadrangle: St Petersburg Major Land Use/Land Cover (1990)
 Section/Township/Range: 20-31S-16E within 500 meters of the lakeshore:
 Approx. Lake Center, Lat/Long: 274630/824328 - high density residential (84%)
 Surface Area: 5 acres - commercial and services (10%)
 Approx. Lake Elevation: 18 feet - institutional (3%)
 Lake Type: isolated (type 4)
 Major Basin: Upper Coastal Drainage
 Minor Basin: St Joe Creek
 Lake Region: Pinellas Peninsula
 Public Access: yes

Total Number of Samples Collected: 2 Most Recent Sample Collected: February 1997

Parameter	Units (Detection Limit)	Average Value	District Percentile	Florida Percentile
Chlorophyll a	ug/l (1)	121.6	>95	>95
Total Phosphorus	mg/l as P (0.01)	0.170	>95	81
Total Nitrogen	mg/l as N (0.06)	2.90	94	91
Transparency (Secchi depth)	meters	0.35	<5	<5
Florida Trophic State Index		86	>95	>95
Specific Conductance	S/cm at 25C (1)	220	67	55
pH	standard units (0.1)	9.3	>95	>95
Color	PtCo units (1)	40	72	30
Turbidity	NTU (1)	31.6	>95	90
Total Alkalinity	mg/l as CaCO3 (1)	70	92	73
Hardness	mg/l as CaCO3 (0.02)	81	80	
Total Suspended Solids	mg/l (0.05)	31.6	>95	
Ammonia	mg/l as N (0.03)	0.030	61	
Nitrate+Nitrite	mg/l as N (0.01)	0.020	51	
Total Kjeldahl Nitrogen	mg/l as N (0.06)	2.88	>95	
Orthophosphorus	mg/l as P (0.01)	0.048	93	
Chloride	mg/l (0.05)	23	69	
Sulfate	mg/l (0.05)	7	27	
Sodium	mg/l (0.06)	12.0	69	
Potassium	mg/l (0.07)	2.6	42	
Calcium	mg/l (0.04)	29.0	91	
Magnesium	mg/l (0.006)	2.0	25	
Iron	ug/l (0.03)	86	78	

Based upon the average FTSI of 86, water quality is considered poor. Pasadena Lake can be characterized as a colored, medium hard water, hypereutrophic lake, with high concentrations of total phosphorus and high concentrations of total nitrogen. The chemical type of water (predominant ionic composition) is calcium chloride.

Also of note:

- The measured pH was very high.

Plots and Trends: No or insufficient data available for plotting or trend detection. Shown is a diagram of the relative ionic composition of the lake water.

MAJOR IONS (% meq/l)

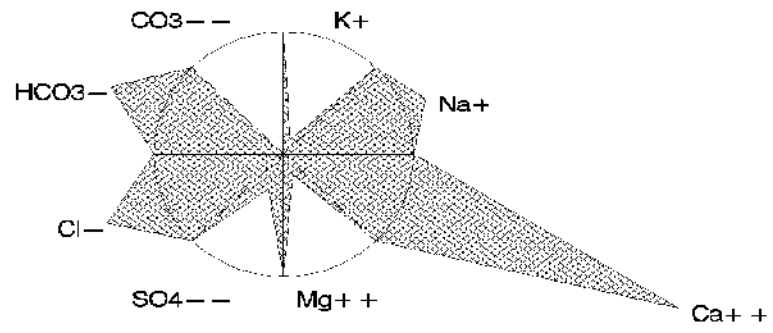

Sawgrass Lake Pinellas County

USGS Quadrangle: St Petersburg Major Land Use/Land Cover (1990)
 Section/Township/Range: 26-30S-16E within 500 meters of the lakeshore:
 Approx. Lake Center, Lat/Long: 275027/824021 - stream and lake swamps (65%)
 Surface Area: 21 acres - high density residential (19%)
 Approx. Lake Elevation: 9 feet - recreational (5%)
 Lake Type: inflow and outflow (type 3)
 Major Basin: Tampa Bay Drainage
 Minor Basin: Grande Bayou
 Lake Region: Pinellas Peninsula
 Public Access: yes

Total Number of Samples Collected: 2 Most Recent Sample Collected: February 1997

Parameter	Units (Detection Limit)	Average Value	District Percentile	Florida Percentile
Chlorophyll a	ug/l (1)	20.8	80	53
Total Phosphorus	mg/l as P (0.01)	0.062	90	46
Total Nitrogen	mg/l as N (0.06)	1.03	42	34
Transparency (Secchi depth)	meters	0.66	17	36
Florida Trophic State Index		57	81	50
Specific Conductance	S/cm at 25C (1)	416	>95	77
pH	standard units (0.1)	8.0	81	70
Color	PtCo units (1)	40	72	30
Turbidity	NTU (1)	5.1	75	51
Total Alkalinity	mg/l as CaCO3 (1)	118	>95	94
Hardness	mg/l as CaCO3 (0.02)	155	>95	
Total Suspended Solids	mg/l (0.05)	6.5	84	
Ammonia	mg/l as N (0.03)	0.015	60	
Nitrate+Nitrite	mg/l as N (0.01)	0.005	33	
Total Kjeldahl Nitrogen	mg/l as N (0.06)	1.03	50	
Orthophosphorus	mg/l as P (0.01)	0.020	85	
Chloride	mg/l (0.05)	49	>95	
Sulfate	mg/l (0.05)	15	50	
Sodium	mg/l (0.06)	22.0	94	
Potassium	mg/l (0.07)	2.8	45	
Calcium	mg/l (0.04)	53.0	>95	
Magnesium	mg/l (0.006)	5.3	72	
Iron	ug/l (0.03)	91	79	

Based upon the average FTSI of 57, water quality is considered good. Sawgrass Lake can be characterized as a colored, hard water, eutrophic lake, with high concentrations of total phosphorus. The chemical type of water (predominant ionic composition) is calcium bicarbonate (1 sample) or calcium chloride (1 sample).

Also of note:

- The measured pH was high.
- Hydrilla was observed in the lake.

Plots and Trends: Shown are plots of lake surface elevation, specific conductance, and pH, and a diagram of the relative ionic composition of the lake water.

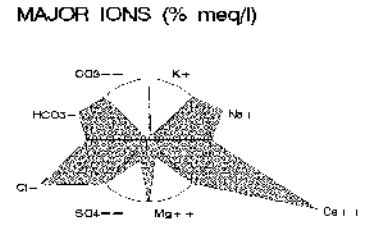
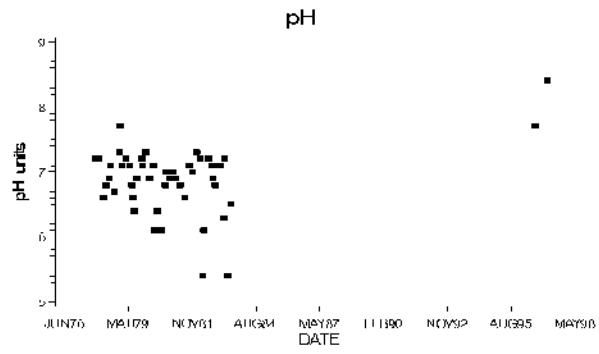
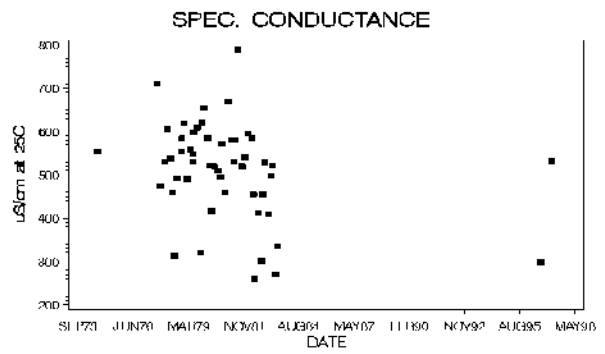
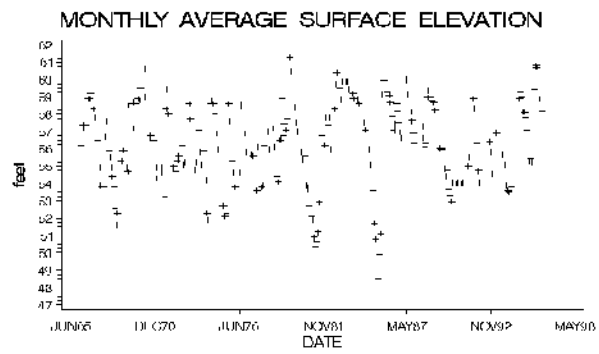

Sawgrass Lake, Pinellas County

Saint George Lake

Pinellas County

USGS Quadrangle: Oldsmar Major Land Use/Land Cover (1990)
 Section/Township/Range: 8-28S-16E within 500 meters of the lakeshore:
 Approx. Lake Center, Lat/Long: 280342/824311 - high density residential (68%)
 Surface Area: 58 acres - stream and lake swamps (11%)
 Approx. Lake Elevation: 14 feet - utilities (6%)
 Lake Type: inflow and outflow (type 3)
 Major Basin: Tampa Bay Drainage
 Minor Basin: Cow Branch
 Lake Region: Pinellas Peninsula

Total Number of Samples Collected: 2 Most Recent Sample Collected: February 1997

Parameter	Units (Detection Limit)	Average Value	District Percentile	Florida Percentile
Chlorophyll a	ug/l (1)	2.9	23	12
Total Phosphorus	mg/l as P (0.01)	0.028	75	18
Total Nitrogen	mg/l as N (0.06)	0.76	24	23
Transparency (Secchi depth)	meters		-	-
Florida Trophic State Index		31	33	6
Specific Conductance	S/cm at 25C (1)	273	84	64
pH	standard units (0.1)	8.3	87	78
Color	PtCo units (1)	15	46	13
Turbidity	NTU (1)	0.5	28	<5
Total Alkalinity	mg/l as CaCO3 (1)	82	95	78
Hardness	mg/l as CaCO3 (0.02)	94	89	
Total Suspended Solids	mg/l (0.05)	0.6	15	
Ammonia	mg/l as N (0.03)	0.042	70	
Nitrate+Nitrite	mg/l as N (0.01)	0.024	57	
Total Kjeldahl Nitrogen	mg/l as N (0.06)	0.74	28	
Orthophosphorus	mg/l as P (0.01)	0.013	72	
Chloride	mg/l (0.05)	33	89	
Sulfate	mg/l (0.05)	10	37	
Sodium	mg/l (0.06)	15.5	85	
Potassium	mg/l (0.07)	4.2	58	
Calcium	mg/l (0.04)	31.0	93	
Magnesium	mg/l (0.006)	4.0	58	
Iron	ug/l (0.03)	20	20	

Based upon the average FTSI of 31, water quality is considered good. Saint George Lake can be characterized as a clear to moderately colored (10<color<20 color units), medium hard water, oligo-mesotrophic lake. The chemical type of water (predominant ionic composition) is calcium chloride.

Also of note:

- The measured pH was high.
- Cattails dominate more than 30% of the lake shoreline.

Plots and Trends: Recent observations of all variables plotted are within the historical ranges. Also shown is a diagram of the relative ionic composition of the lake water.

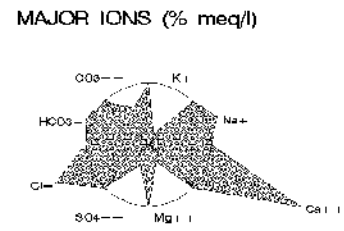
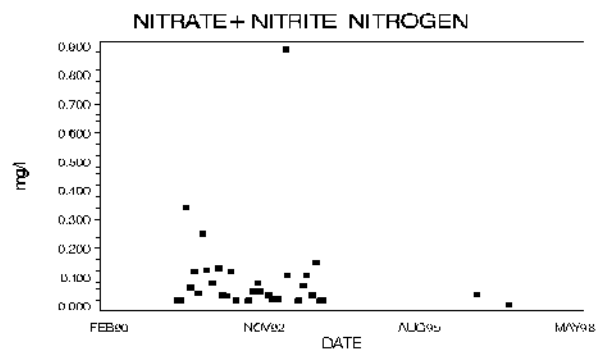
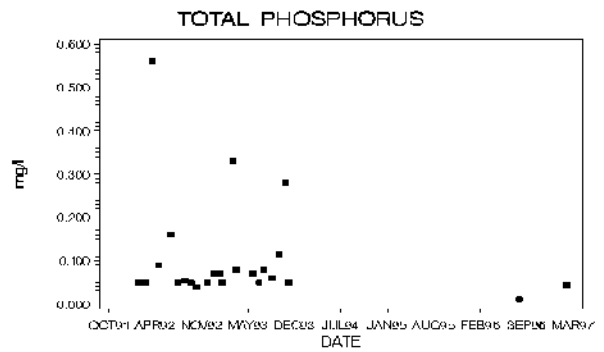
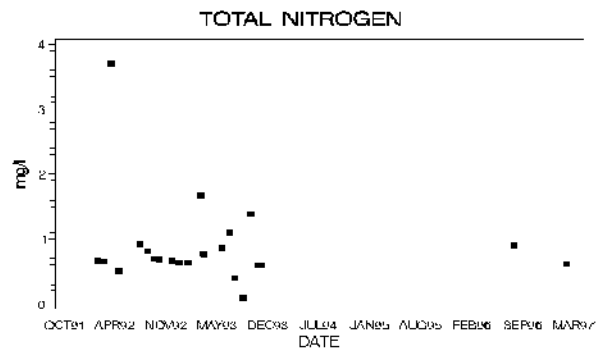
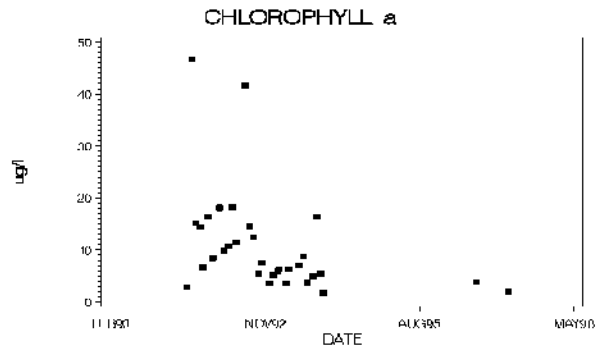
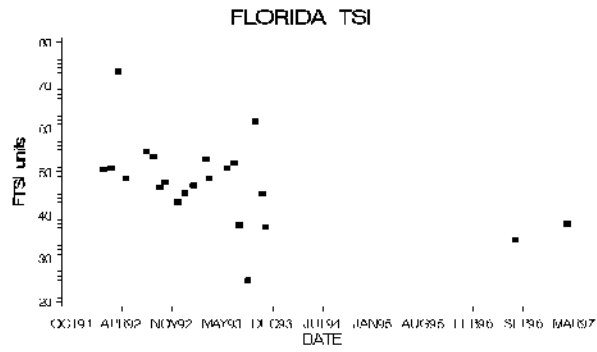
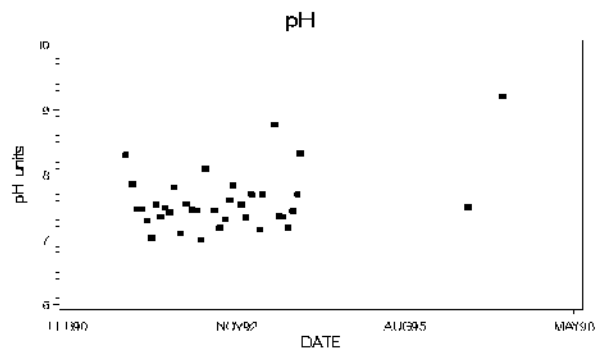
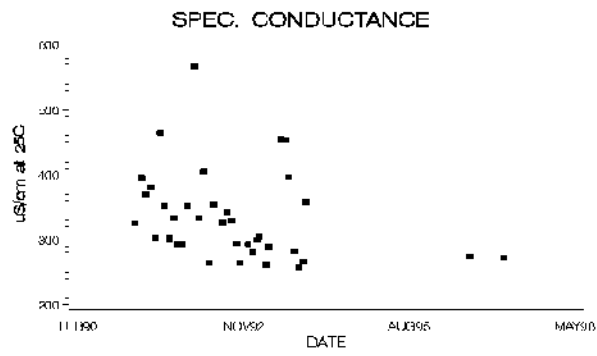

Saint George Lake, Pinellas County

Taylor Lake

Pinellas County

USGS Quadrangle: Clearwater Major Land Use/Land Cover (1990)
 Section/Township/Range: 4-30S-15E within 500 meters of the lakeshore:
 Approx. Lake Center, Lat/Long: 275417/824816 - high density residential (53%)
 Surface Area: 50 acres - recreational (16%)
 Approx. Lake Elevation: 32 feet - institutional (10%)
 Lake Type: inflow and outflow (type 3)
 Major Basin: Upper Coastal Drainage
 Minor Basin: McKay Creek
 Lake Region: Pinellas Peninsula

Total Number of Samples Collected: 2 Most Recent Sample Collected: February 1997

Parameter	Units (Detection Limit)	Average Value	District Percentile	Florida Percentile
Chlorophyll a	ug/l (1)	18.0	77	49
Total Phosphorus	mg/l as P (0.01)	0.037	81	27
Total Nitrogen	mg/l as N (0.06)	0.62	12	16
Transparency (Secchi depth)	meters	0.98	33	63
Florida Trophic State Index		46	65	27
Specific Conductance	S/cm at 25C (1)	478	>95	80
pH	standard units (0.1)	8.0	81	70
Color	PtCo units (1)	20	55	17
Turbidity	NTU (1)	4.2	71	43
Total Alkalinity	mg/l as CaCO3 (1)	133	>95	>95
Hardness	mg/l as CaCO3 (0.02)	171	>95	
Total Suspended Solids	mg/l (0.05)	5.0	78	
Ammonia	mg/l as N (0.03)	0.015	60	
Nitrate+Nitrite	mg/l as N (0.01)	0.005	33	
Total Kjeldahl Nitrogen	mg/l as N (0.06)	0.62	17	
Orthophosphorus	mg/l as P (0.01)	0.010	59	
Chloride	mg/l (0.05)	55	>95	
Sulfate	mg/l (0.05)	28	74	
Sodium	mg/l (0.06)	28.5	>95	
Potassium	mg/l (0.07)	7.4	83	
Calcium	mg/l (0.04)	55.0	>95	
Magnesium	mg/l (0.006)	8.2	84	
Iron	ug/l (0.03)	43	55	

Based upon the average FTSI of 46, water quality is considered good. Taylor Lake can be characterized as a moderately colored, hard water, eutrophic lake, with high concentrations of total phosphorus. The chemical type of water (predominant ionic composition) is calcium bicarbonate (1 sample) or calcium chloride (1 sample).

Also of note:

- The measured pH was high.

Plots and Trends: Specific conductance is greater for observations in the 1990s than for those made in the 1960s. Recent measures of other analytes are generally within their historic ranges. Also shown is a diagram of the relative ionic composition of the lake water.

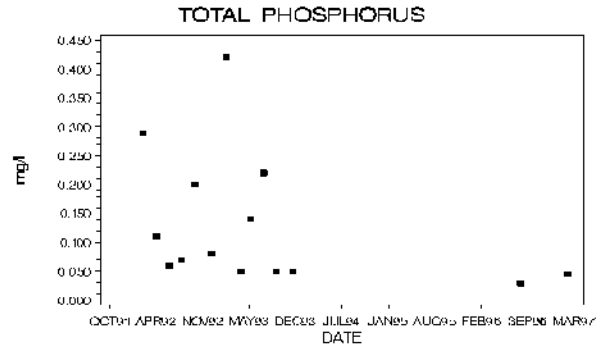
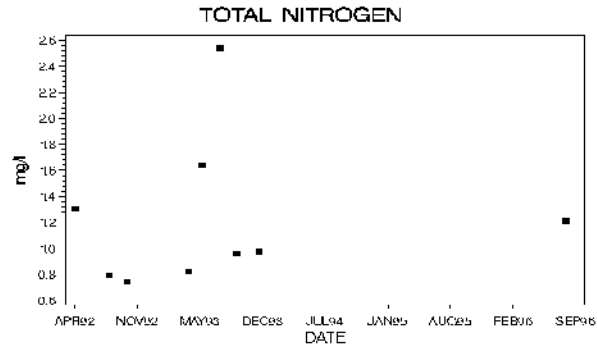
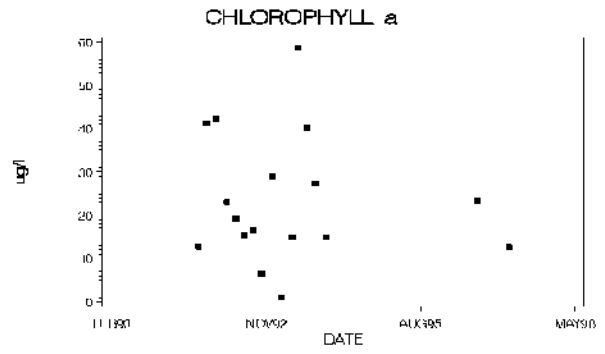
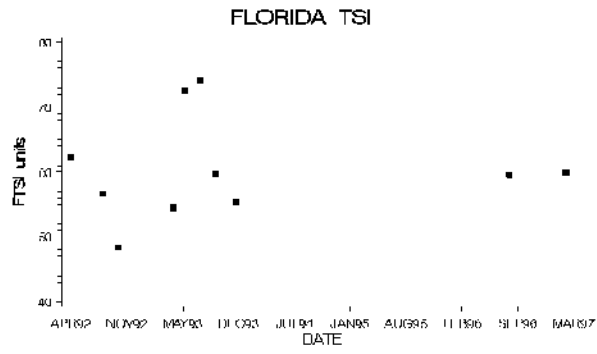
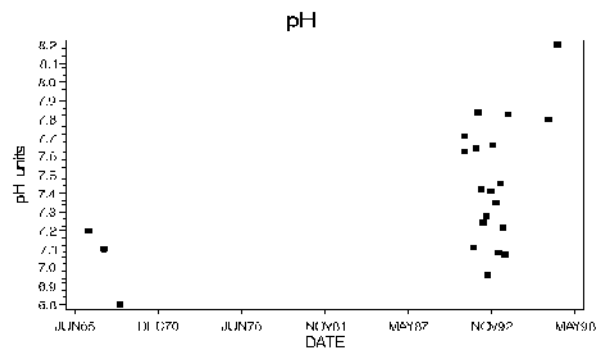
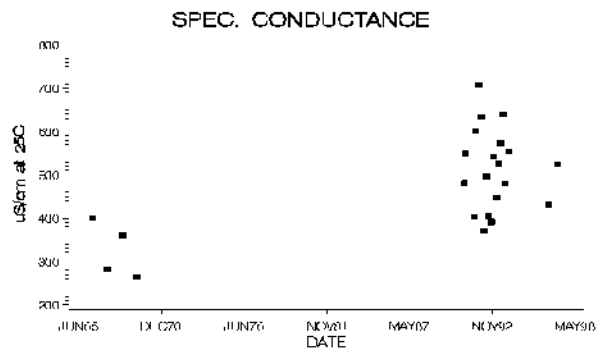

MAJOR IONS (% meq/l)

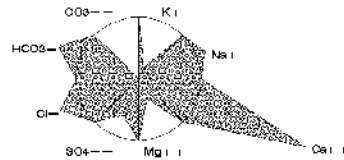

Taylor Lake, Pinellas County

Lake Agnes

Polk County

USGS Quadrangle: Polk City Major Land Use/Land Cover (1990)
 Section/Township/Range: 4-27S-25E within 500 meters of the lakeshore:
 Approx. Lake Center, Lat/Long: 281009/814906 - medium density residential (28%)
 Surface Area: 386 acres - cropland and pastureland (20%)
 Approx. Lake Elevation: 136 feet - other open lands - rural (19%)
 Observed Maximum Depth: 11.5 feet
 (reference elevation not given)
 Lake Type: inflow and outflow (type 3)
 Major Basin: Withlacoochee River
 Minor Basin: Lake Agnes Outlet
 Lake Region: Winter Haven/Lake Henry Ridges
 Public Access: yes

Total Number of Samples Collected: 2 Most Recent Sample Collected: January 1997

Parameter	Units (Detection Limit)	Average Value	District Percentile	Florida Percentile
Chlorophyll a	ug/l (1)	20.3	80	52
Total Phosphorus	mg/l as P (0.01)	0.017	58	9
Total Nitrogen	mg/l as N (0.06)	0.74	21	22
Transparency (Secchi depth)	meters	1.08	37	66
Florida Trophic State Index		51	75	38
Specific Conductance	S/cm at 25C (1)	142	32	40
pH	standard units (0.1)	8.5	91	83
Color	PtCo units (1)	20	55	17
Turbidity	NTU (1)	3.4	66	36
Total Alkalinity	mg/l as CaCO3 (1)	7	18	20
Hardness	mg/l as CaCO3 (0.02)	32	25	
Total Suspended Solids	mg/l (0.05)	2.1	54	
Ammonia	mg/l as N (0.03)	0.015	60	
Nitrate+Nitrite	mg/l as N (0.01)	0.005	33	
Total Kjeldahl Nitrogen	mg/l as N (0.06)	0.74	28	
Orthophosphorus	mg/l as P (0.01)	0.005	56	
Chloride	mg/l (0.05)	20	56	
Sulfate	mg/l (0.05)	23	67	
Sodium	mg/l (0.06)	9.2	54	
Potassium	mg/l (0.07)	6.5	78	
Calcium	mg/l (0.04)	2.1	<5	
Magnesium	mg/l (0.006)	6.4	79	
Iron	ug/l (0.03)	34	46	

Based upon the average FTSI of 51, water quality is considered good. Lake Agnes can be characterized as a moderately colored, soft water, eutrophic lake. The chemical type of water (predominant ionic composition) is sodium chloride.

Also of note:

- the measured pH was high

Plots and Trends: No trends evident in lake surface elevation. Also shown is a diagram of the relative ionic composition of the lake water.

MONTHLY AVERAGE SURFACE ELEVATION

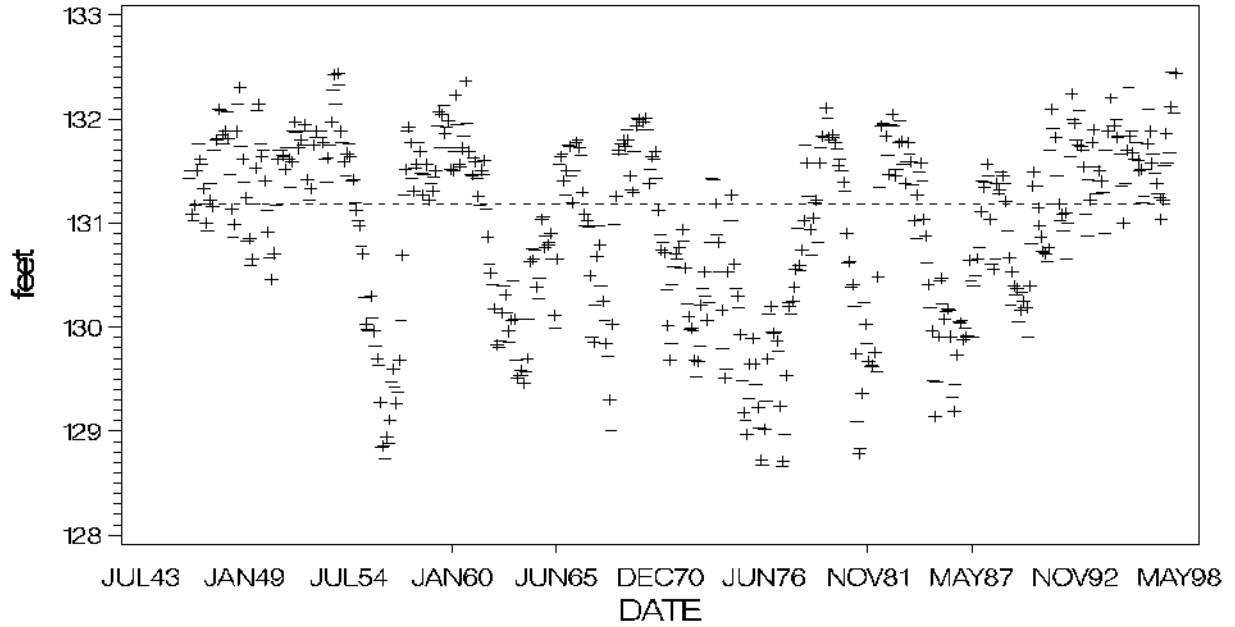

MAJOR IONS (% meq/l)

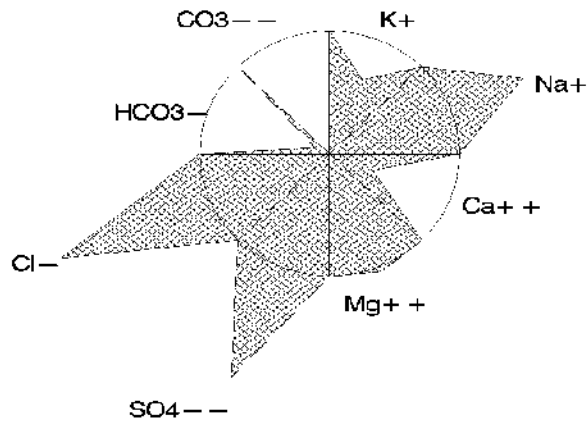

Lake Alfred

Polk County

USGS Quadrangle: Winter Haven Major Land Use/Land Cover (1990)
 Section/Township/Range: 30-27S-26E within 500 meters of the lakeshore:
 Approx. Lake Center, Lat/Long: 280601/814442 - tree crops, typically citrus (30%)
 Surface Area: 736 acres - freshwater marshes (21%)
 Approx. Lake Elevation: 131 feet - medium density residential (16%)
 Observed Maximum Depth: 11.5 feet
 (reference elevation not given)
 Lake Type: inflow (type 1)
 Major Basin: Peace River
 Minor Basin: Lake Fannie Outlet
 Lake Region: Winter Haven/Lake Henry Ridges
 Public Access: yes

Total Number of Samples Collected: 2 Most Recent Sample Collected: February 1997

Parameter	Units (Detection Limit)	Average Value	District Percentile	Florida Percentile
Chlorophyll a	ug/l (1)	13.6	72	43
Total Phosphorus	mg/l as P (0.01)	0.018	61	9
Total Nitrogen	mg/l as N (0.06)	1.25	57	43
Transparency (Secchi depth)	meters	1.31	46	72
Florida Trophic State Index		49	71	34
Specific Conductance	S/cm at 25C (1)	268	84	63
pH	standard units (0.1)	7.9	78	67
Color	PtCo units (1)	20	55	17
Turbidity	NTU (1)	2.6	59	28
Total Alkalinity	mg/l as CaCO3 (1)	58	86	67
Hardness	mg/l as CaCO3 (0.02)	82	82	
Total Suspended Solids	mg/l (0.05)	3.6	69	
Ammonia	mg/l as N (0.03)	0.015	60	
Nitrate+Nitrite	mg/l as N (0.01)	0.005	33	
Total Kjeldahl Nitrogen	mg/l as N (0.06)	1.25	65	
Orthophosphorus	mg/l as P (0.01)	0.008	56	
Chloride	mg/l (0.05)	38	95	
Sulfate	mg/l (0.05)	31	79	
Sodium	mg/l (0.06)	20.5	93	
Potassium	mg/l (0.07)	14.5	>95	
Calcium	mg/l (0.04)	14.5	58	
Magnesium	mg/l (0.006)	11.0	90	
Iron	ug/l (0.03)	12	6	

Based upon the average FTSI of 49, water quality is considered good. Lake Alfred can be characterized as a moderately colored, medium hard water, eutrophic lake. The chemical type of water (predominant ionic composition) is sodium chloride.

Also of note:

- Cattails dominate more than 30% of the lake shoreline

Plots and Trends: Lake levels have generally risen from the lows recorded in the mid-1970s. Also shown is a diagram of the relative ionic composition of the lake water.

MONTHLY AVERAGE SURFACE ELEVATION

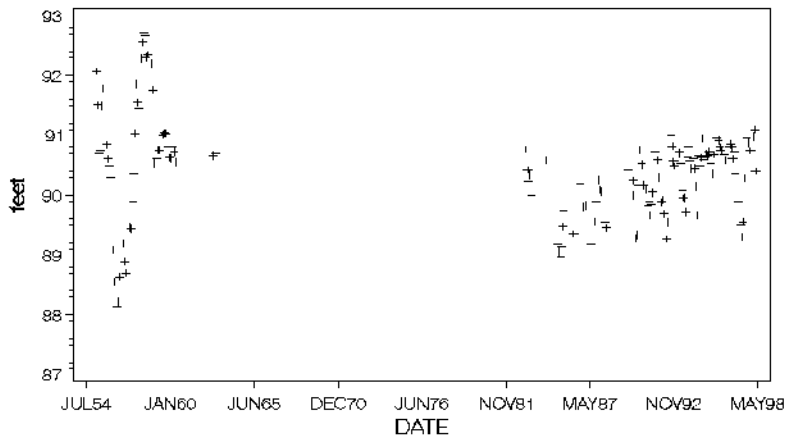

SPEC. CONDUCTANCE

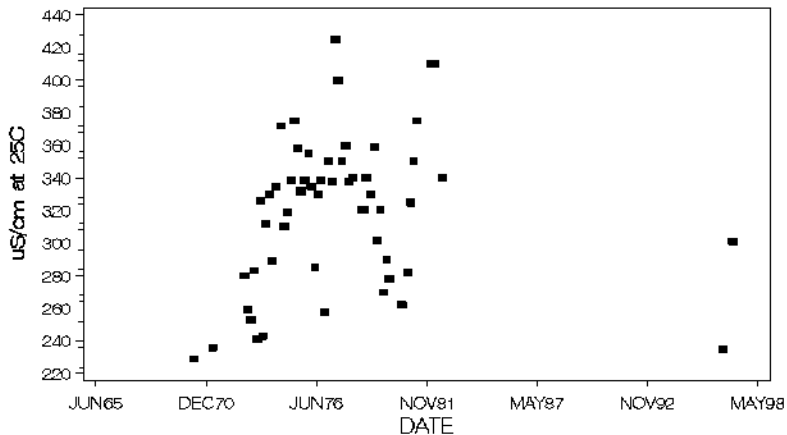

MAJOR IONS (% meq/l)

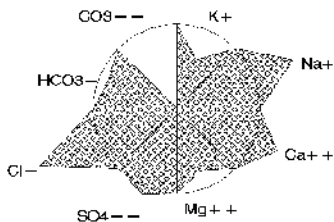

Lake Alfred, Polk County

Lake Ariana

Polk County

USGS Quadrangle: Auburndale Major Land Use/Land Cover (1990)
 Section/Township/Range: 3-28S-25E within 500 meters of the lakeshore:
 Approx. Lake Center, Lat/Long: 280444/814753 - medium density residential (64%)
 Surface Area: 1026 acres - tree crops, typically citrus (8%)
 Approx. Lake Elevation: 137 feet - institutional (7%)
 Average Depth: 15.8 feet
 Observed Maximum Depth: 26 feet
 (reference elevation 134.1 feet)
 Lake Type: inflow and outflow (type 3)
 Major Basin: Peace River
 Minor Basin: Lake Lena Run
 Lake Region: Winter Haven/Lake Henry Ridges
 Public Access: yes

Total Number of Samples Collected: 2 Most Recent Sample Collected: January 1997

Parameter	Units (Detection Limit)	Average Value	District Percentile	Florida Percentile
Chlorophyll a	ug/l (1)	12.8	71	42
Total Phosphorus	mg/l as P (0.01)	0.005	31	<5
Total Nitrogen	mg/l as N (0.06)	0.80	26	25
Transparency (Secchi depth)	meters	1.36	47	73
Florida Trophic State Index		39	52	15
Specific Conductance	S/cm at 25C (1)	247	77	60
pH	standard units (0.1)	8.9	>95	91
Color	PtCo units (1)	8	24	8
Turbidity	NTU (1)	2.5	58	26
Total Alkalinity	mg/l as CaCO3 (1)	37	69	54
Hardness	mg/l as CaCO3 (0.02)	76	76	
Total Suspended Solids	mg/l (0.05)	1.7	44	
Ammonia	mg/l as N (0.03)	0.015	60	
Nitrate+Nitrite	mg/l as N (0.01)	0.005	33	
Total Kjeldahl Nitrogen	mg/l as N (0.06)	0.80	32	
Orthophosphorus	mg/l as P (0.01)	0.009	56	
Chloride	mg/l (0.05)	23	69	
Sulfate	mg/l (0.05)	43	90	
Sodium	mg/l (0.06)	14.0	80	
Potassium	mg/l (0.07)	6.5	78	
Calcium	mg/l (0.04)	15.0	60	
Magnesium	mg/l (0.006)	9.3	86	
Iron	ug/l (0.03)	21	22	

Based upon the average FTSI of 39, water quality is considered good. Lake Ariana can be characterized as a clear (color<=10 color units), medium hard water, eutrophic lake, with low concentrations of total phosphorus. The chemical type of water (predominant ionic composition) is calcium sulfate.

Also of note:

- The measured pH was high
- Cattails dominate more than 30% of the lake shoreline.

Plots and Trends: The range in elevation fluctuation over the period of record was over 6 feet. Lake elevation has generally increased over the past decade, but no long-term trend is clear for lake elevation. There is no trend in specific conductance for the period of record. Also shown is a diagram of the relative ionic composition of the lake water.

MONTHLY AVERAGE SURFACE ELEVATION

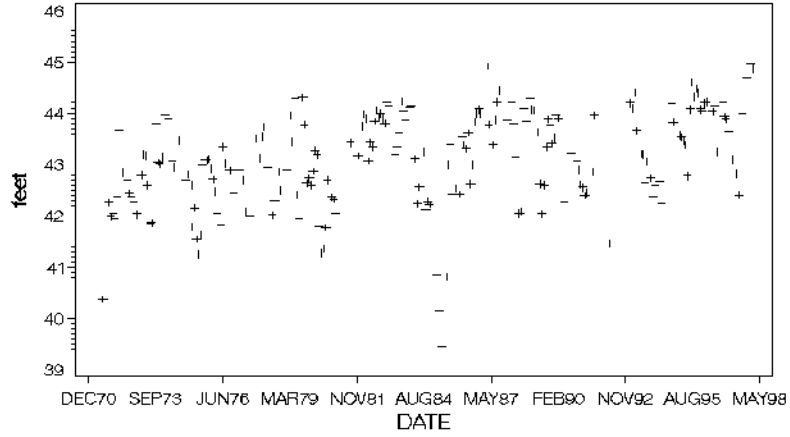

SPEC. CONDUCTANCE

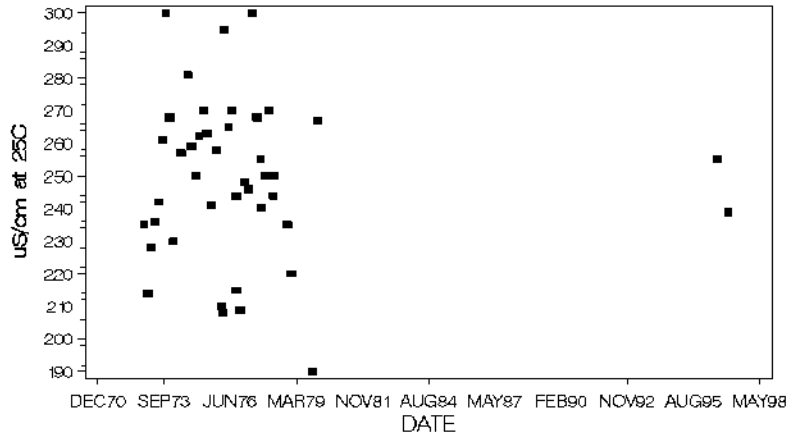

MAJOR IONS (% meq/l)

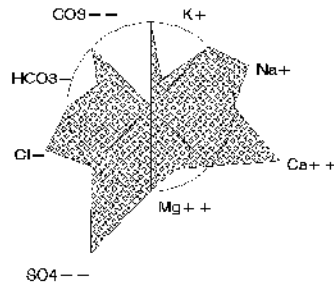

Lake Ariana, Polk County

Lake Arietta

Polk County

USGS Quadrangle: Auburndale Major Land Use/Land Cover (1990)
 Section/Township/Range: 27-27S-25E within 500 meters of the lakeshore:
 Approx. Lake Center, Lat/Long: 280609/814813 - tree crops, typically citrus (43%)
 Surface Area: 758 acres - medium density residential (29%)
 Approx. Lake Elevation: 144 feet - cropland and pastureland (11%)
 Average Depth: 18.5 feet
 (reference elevation not given)
 Lake Type: outflow (type 2)
 Major Basin: Peace River
 Minor Basin: Lake Lena Run
 Lake Region: Winter Haven/Lake Henry Ridges

Total Number of Samples Collected: 2 Most Recent Sample Collected: January 1995

Parameter	Units (Detection Limit)	Average Value	District Percentile	Florida Percentile
Chlorophyll a	ug/l (1)	5.0	44	20
Total Phosphorus	mg/l as P (0.01)	0.010	33	5
Total Nitrogen	mg/l as N (0.06)	1.08	47	36
Transparency (Secchi depth)	meters	2.95	82	>95
Florida Trophic State Index		24	12	<5
Specific Conductance	S/cm at 25C (1)	267	83	63
pH	standard units (0.1)	6.6	18	20
Color	PtCo units (1)	5	9	5
Turbidity	NTU (1)	1.3	36	10
Total Alkalinity	mg/l as CaCO3 (1)	3	7	8
Hardness	mg/l as CaCO3 (0.02)	66	69	
Total Suspended Solids	mg/l (0.05)	1.6	42	
Ammonia	mg/l as N (0.03)	0.015	60	
Nitrate+Nitrite	mg/l as N (0.01)	0.015	44	
Total Kjeldahl Nitrogen	mg/l as N (0.06)	1.07	53	
Orthophosphorus	mg/l as P (0.01)	0.005	56	
Chloride	mg/l (0.05)	34	90	
Sulfate	mg/l (0.05)	60	>95	
Sodium	mg/l (0.06)	15.5	85	
Potassium	mg/l (0.07)	10.5	91	
Calcium	mg/l (0.04)	2.4	<5	
Magnesium	mg/l (0.006)	14.5	>95	
Iron	ug/l (0.03)	27	33	

Based upon the average FTSI of 24, water quality is considered good. Lake Arietta can be characterized as a clear (color<=10 color units), medium hard water, oligo-mesotrophic lake. The chemical type of water (predominant ionic composition) is sodium sulfate.

Plots and Trends: The range in elevation fluctuation over the period of record was nearly 7 feet, and recently recorded elevations are the highest for the period of record. Lake elevation has generally increased over the past decade, but no long-term trend is clear for lake elevation. Also shown is a diagram of the relative ionic composition of the lake water.

MONTHLY AVERAGE SURFACE ELEVATION

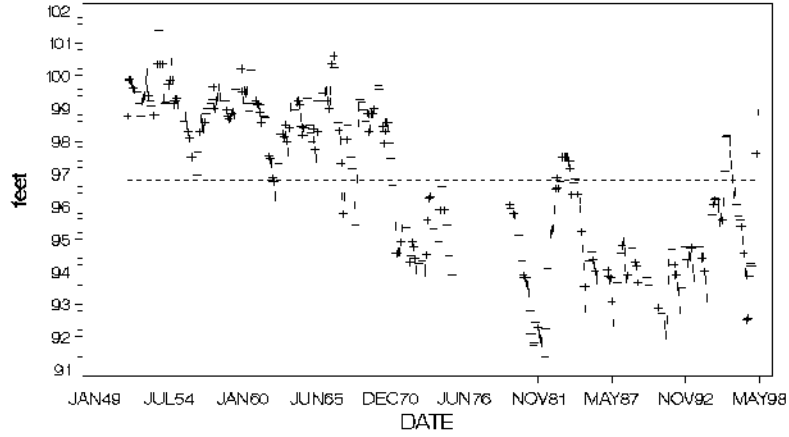

SPEC. CONDUCTANCE

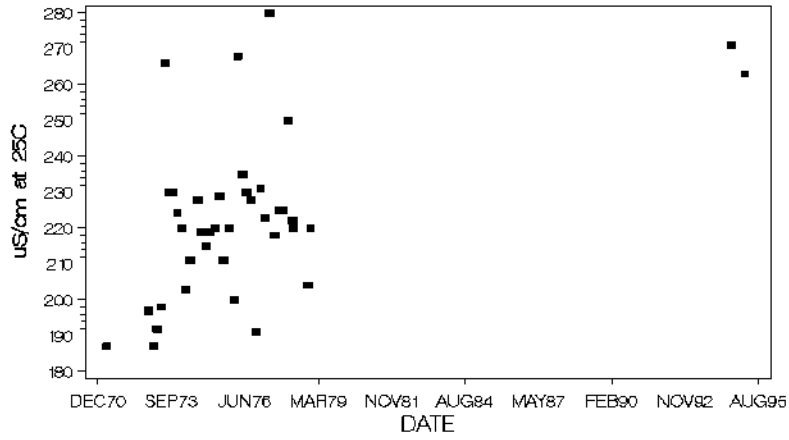

MAJOR IONS (% meq/l)

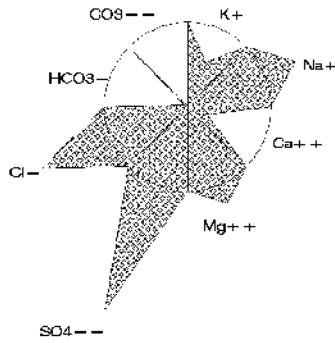

Lake Arietta, Polk County

Lake Bess

Polk County

USGS Quadrangle: Eloise
 Section/Township/Range: 18-29S-27E
 Approx. Lake Center, Lat/Long: 275800/813912
 Surface Area: 148 acres
 Approx. Lake Elevation: 125 feet
 Observed Maximum Depth: 9.8 feet
 (reference elevation not given)
 Lake Type: inflow and outflow (type 3)
 Major Basin: Peace River
 Minor Basin: Lake Myrtle Outlet
 Lake Region: Winter Haven/Lake Henry Ridges
 Public Access: yes

Major Land Use/Land Cover (1990)
 within 500 meters of the lakeshore:
 - tree crops, typically citrus (38%)
 - stream and lake swamps (14%)
 - recreational (12%)

Total Number of Samples Collected: 2 Most Recent Sample Collected: January 1997

Parameter	Units (Detection Limit)	Average Value	District Percentile	Florida Percentile
Chlorophyll a	ug/l (1)	7.0	53	30
Total Phosphorus	mg/l as P (0.01)	0.013	46	7
Total Nitrogen	mg/l as N (0.06)	1.15	52	38
Transparency (Secchi depth)	meters	2.12	68	87
Florida Trophic State Index		37	48	12
Specific Conductance	S/cm at 25C (1)	353	93	73
pH	standard units (0.1)	7.6	64	57
Color	PtCo units (1)	8	24	8
Turbidity	NTU (1)	1.7	45	16
Total Alkalinity	mg/l as CaCO3 (1)	32	62	51
Hardness	mg/l as CaCO3 (0.02)	117	94	
Total Suspended Solids	mg/l (0.05)	1.5	39	
Ammonia	mg/l as N (0.03)	0.032	63	
Nitrate+Nitrite	mg/l as N (0.01)	0.018	48	
Total Kjeldahl Nitrogen	mg/l as N (0.06)	1.13	58	
Orthophosphorus	mg/l as P (0.01)	0.011	64	
Chloride	mg/l (0.05)	35	92	
Sulfate	mg/l (0.05)	76	>95	
Sodium	mg/l (0.06)	13.0	76	
Potassium	mg/l (0.07)	12.0	93	
Calcium	mg/l (0.04)	19.5	74	
Magnesium	mg/l (0.006)	16.5	>95	
Iron	ug/l (0.03)	44	57	

Based upon the average FTSI of 37, water quality is considered good. Lake Bess can be characterized as a clear (color<=10 color units), medium hard water, meso-eutrophic lake. The chemical type of water (predominant ionic composition) is calcium sulfate.

Plots and Trends: The plot of lake surface elevation shows increasing elevation since the low s recorded in 1989-1990, however, the period of record is relatively short. Also shown is a diagram of the relative ionic composition of the lake water.

MONTHLY AVERAGE SURFACE ELEVATION

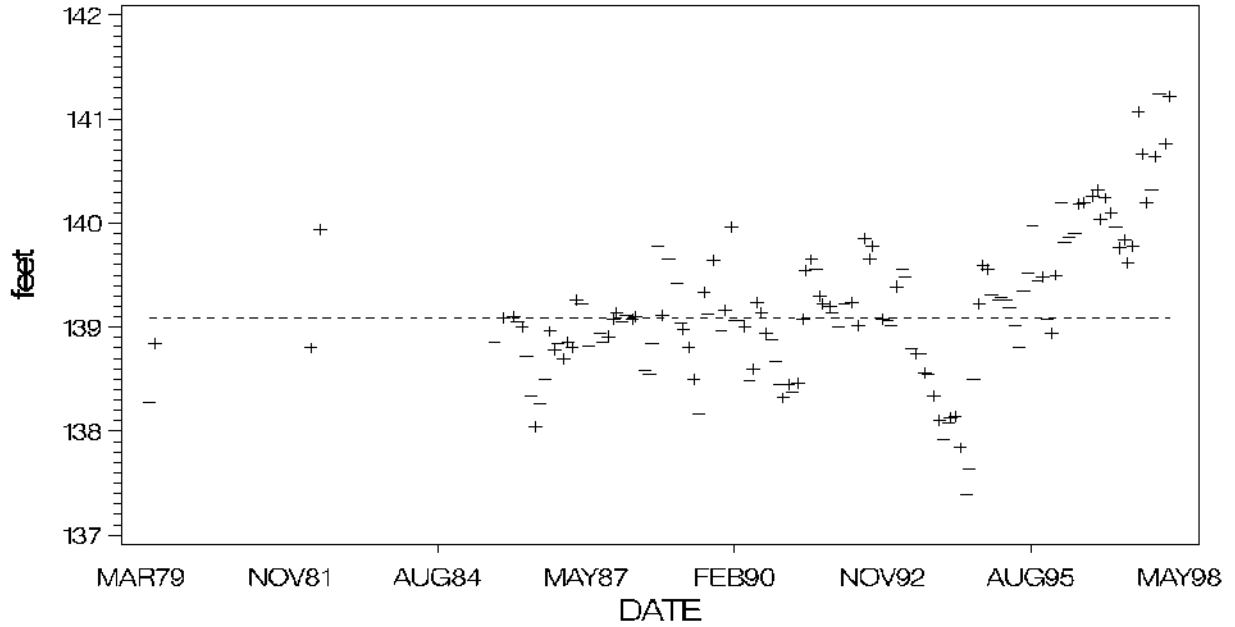

MAJOR IONS (% meq/l)

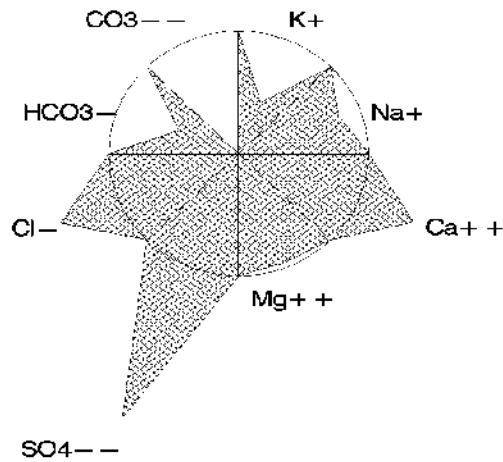

Blue Lake (Big) Polk County

USGS Quadrangle:	Babson Park	Major Land Use/Land Cover (1990)
Section/Township/Range:	24-30S-27E	within 500 meters of the lakeshore:
Approx. Lake Center, Lat/Long:	275105/813439	- tree crops, typically citrus (58%)
Surface Area:	94 acres	- other open lands - rural (13%)
Approx. Lake Elevation:	110 feet	- medium density residential (11%)
Average Depth: 30 feet		
Observed Maximum Depth: 55 feet		
(reference elevation 110 feet)		
Lake Type: isolated (type 4)		
Major Basin: Peace River		
Minor Basin: Peace Cr Trib Canal		
Lake Region: Northern Lake Wales Ridge		
Public Access: yes		

Total Number of Samples Collected: 2 Most Recent Sample Collected: January 1996

Parameter	Units (Detection Limit)	Average Value	District Percentile	Florida Percentile
Chlorophyll a	ug/l (1)	1.6	7	6
Total Phosphorus	mg/l as P (0.01)	0.011	38	6
Total Nitrogen	mg/l as N (0.06)	2.32	90	85
Transparency (Secchi depth)	meters	4.40	95	>95
Florida Trophic State Index		25	14	<5
Specific Conductance	S/cm at 25C (1)	223	67	56
pH	standard units (0.1)	7.8	74	63
Color	PtCo units (1)	5	9	5
Turbidity	NTU (1)	0.5	28	<5
Total Alkalinity	mg/l as CaCO3 (1)	30	58	49
Hardness	mg/l as CaCO3 (0.02)	77	77	
Total Suspended Solids	mg/l (0.05)	0.2	<5	
Ammonia	mg/l as N (0.03)	0.038	67	
Nitrate+Nitrite	mg/l as N (0.01)	1.367	95	
Total Kjeldahl Nitrogen	mg/l as N (0.06)	0.96	44	
Orthophosphorus	mg/l as P (0.01)	0.011	64	
Chloride	mg/l (0.05)	22	64	
Sulfate	mg/l (0.05)	29	75	
Sodium	mg/l (0.06)	8.5	48	
Potassium	mg/l (0.07)	6.7	79	
Calcium	mg/l (0.04)	10.0	39	
Magnesium	mg/l (0.006)	12.5	92	
Iron	ug/l (0.03)	21	22	

Based upon the average FTSI of 25, water quality is considered good. Blue Lake (Big) can be characterized as a clear (color<=10 color units), medium hard water, oligotrophic lake, with high concentrations of total nitrogen and high nitrate concentrations. The chemical type of water (predominant ionic composition) is calcium chloride (1 sample) or magnesium chloride.

Also of note:

- Cattails dominate more than 30% of the lake shoreline.

Plots and Trends: Big Blue Lake and Little Blue Lake are connected above a surface elevation of 111 feet. Lake elevations are recorded from a gage on Little Blue Lake, however, the elevation of the two lakes is probably very similar even when they are not joined. The period of record for lake surface elevation is relatively long, beginning in 1967. The range in fluctuation over the period of record is nearly 10 feet. There is no trend evident. Also shown is a diagram of the relative ionic composition of the lake water.

MONTHLY AVERAGE SURFACE ELEVATION

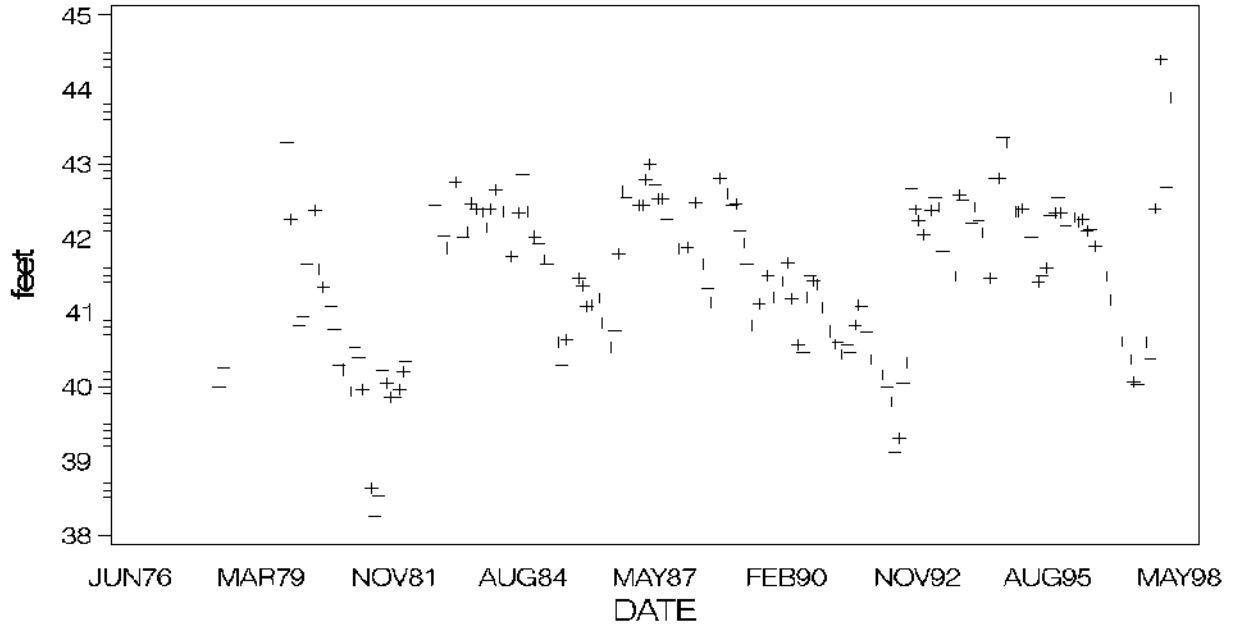

MAJOR IONS (% meq/l)

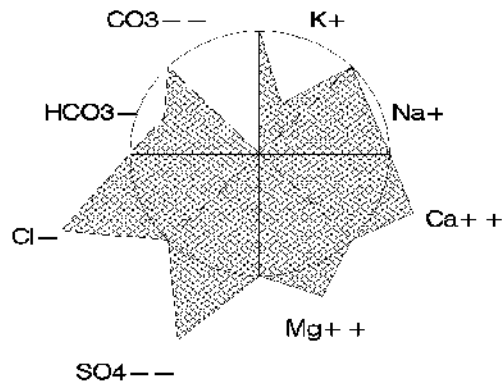

Blue Lake (Big), Polk County

Blue Lake (Little) Polk County

USGS Quadrangle:	Babson Park	Major Land Use/Land Cover (1990)
Section/Township/Range:	24-30S-27E	within 500 meters of the lakeshore:
Approx. Lake Center, Lat/Long:	275121/813450	- tree crops, typically citrus (55%)
Surface Area:	24 acres	- other open lands - rural (20%)
Approx. Lake Elevation:	110 feet	- low density residential (10%)
Average Depth: 23.3 feet		
Observed Maximum Depth: 48 feet		
(reference elevation 110 feet)		
Lake Type: isolated (type 4)		
Major Basin: Peace River		
Minor Basin: Peace Cr Trib Canal		
Lake Region: Northern Lake Wales Ridge		

Total Number of Samples Collected: 2 Most Recent Sample Collected: January 1996

Parameter	Units (Detection Limit)	Average Value	District Percentile	Florida Percentile
Chlorophyll a	ug/l (1)	1.0	<5	<5
Total Phosphorus	mg/l as P (0.01)	0.012	41	6
Total Nitrogen	mg/l as N (0.06)	4.80	>95	>95
Transparency (Secchi depth)	meters	7.30	>95	>95
Florida Trophic State Index		17	<5	<5
Specific Conductance	S/cm at 25C (1)	264	81	63
pH	standard units (0.1)	7.6	64	57
Color	PtCo units (1)	5	9	5
Turbidity	NTU (1)	0.5	28	<5
Total Alkalinity	mg/l as CaCO3 (1)	29	57	48
Hardness	mg/l as CaCO3 (0.02)	99	90	
Total Suspended Solids	mg/l (0.05)	0.0	<5	
Ammonia	mg/l as N (0.03)	0.046	72	
Nitrate+Nitrite	mg/l as N (0.01)	4.297	>95	
Total Kjeldahl Nitrogen	mg/l as N (0.06)	0.50	8	
Orthophosphorus	mg/l as P (0.01)	0.011	64	
Chloride	mg/l (0.05)	20	56	
Sulfate	mg/l (0.05)	39	87	
Sodium	mg/l (0.06)	6.1	23	
Potassium	mg/l (0.07)	9.7	89	
Calcium	mg/l (0.04)	19.0	72	
Magnesium	mg/l (0.006)	12.5	92	
Iron	ug/l (0.03)	15	9	

Based upon the average FTSI of 17, water quality is considered good. Blue Lake (Little) can be characterized as a clear (color≤10 color units), medium hard water, oligotrophic lake, with high concentrations of total nitrogen, very high nitrate concentrations. The chemical type of water (predominant ionic composition) is calcium sulfate.

Plots and Trends: Little Blue Lake and Big Blue Lake are connected above a surface elevation of 111 feet. Lake elevations are recorded from a gage on Little Blue Lake, however, the elevation of the two lakes is probably very similar even when they are not joined. The period of record for lake surface elevation is relatively long, beginning in 1967. The range in fluctuation over the period of record is nearly 10 feet. There is no trend evident. Also shown is a diagram of the relative ionic composition of the lake water.

MONTHLY AVERAGE SURFACE ELEVATION

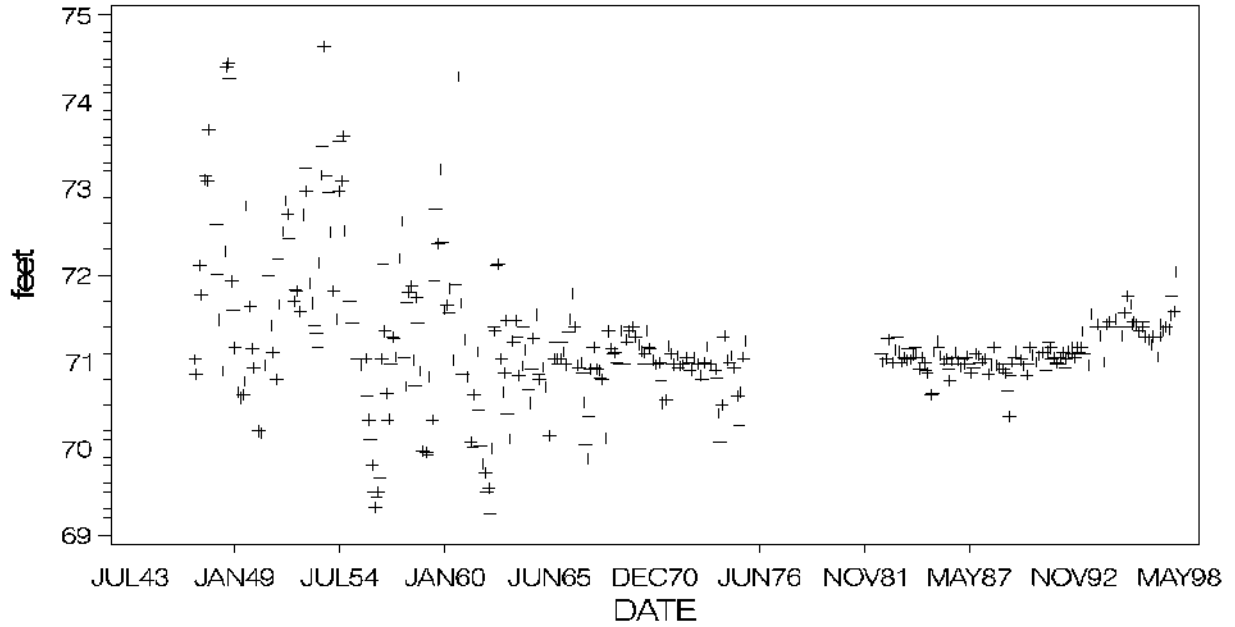

MAJOR IONS (% meq/l)

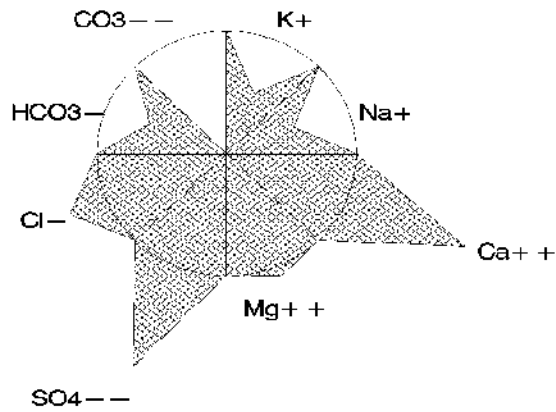

Blue Lake (Little), Polk County

Lake Bonny

Polk County

USGS Quadrangle: Lakeland Major Land Use/Land Cover (1990)
 Section/Township/Range: 20-28S-24E within 500 meters of the lakeshore:
 Approx. Lake Center, Lat/Long: 280217/815530 - medium density residential (32%)
 Surface Area: 354 acres - high density residential (19%)
 Approx. Lake Elevation: 131 feet - commercial and services (12%)
 Observed Maximum Depth: 8.2 feet
 (reference elevation not given)
 Lake Type: outflow (type 2)
 Major Basin: Peace River
 Minor Basin: Saddle Creek
 Lake Region: Lakeland/Bone Valley Upland
 Public Access: yes

Total Number of Samples Collected: 2 Most Recent Sample Collected: January 1997

Parameter	Units (Detection Limit)	Average Value	District Percentile	Florida Percentile
Chlorophyll a	ug/l (1)	33.9	87	69
Total Phosphorus	mg/l as P (0.01)	0.038	82	28
Total Nitrogen	mg/l as N (0.06)	1.60	72	65
Transparency (Secchi depth)	meters	0.51	11	21
Florida Trophic State Index		65	90	66
Specific Conductance	S/cm at 25C (1)	131	25	36
pH	standard units (0.1)	8.8	95	90
Color	PtCo units (1)	20	55	17
Turbidity	NTU (1)	8.9	85	66
Total Alkalinity	mg/l as CaCO3 (1)	42	74	57
Hardness	mg/l as CaCO3 (0.02)	48	50	
Total Suspended Solids	mg/l (0.05)	15.6	>95	
Ammonia	mg/l as N (0.03)	0.015	60	
Nitrate+Nitrite	mg/l as N (0.01)	0.005	33	
Total Kjeldahl Nitrogen	mg/l as N (0.06)	1.60	80	
Orthophosphorus	mg/l as P (0.01)	0.014	76	
Chloride	mg/l (0.05)	9	12	
Sulfate	mg/l (0.05)	8	31	
Sodium	mg/l (0.06)	6.1	23	
Potassium	mg/l (0.07)	2.4	39	
Calcium	mg/l (0.04)	15.5	62	
Magnesium	mg/l (0.006)	2.2	31	
Iron	ug/l (0.03)	35	47	

Based upon the average FTSI of 65, water quality is considered fair. Lake Bonny can be characterized as a moderately colored, soft water, eutrophic to hypereutrophic lake, with high concentrations of total phosphorus. The chemical type of water (predominant ionic composition) is calcium bicarbonate.

Also of note:

- The measured pH was high.
- Cattails dominate more than 30% of the lake shoreline.

Plots and Trends: The period of record for lake surface elevation is incomplete. The plot shows similar elevations for the 1980s and 1990s as for the period 1954 to 1960. The range in elevation fluctuation is between 9 and 10 feet. Also shown is a diagram of the relative ionic composition of the lake water.

MONTHLY AVERAGE SURFACE ELEVATION

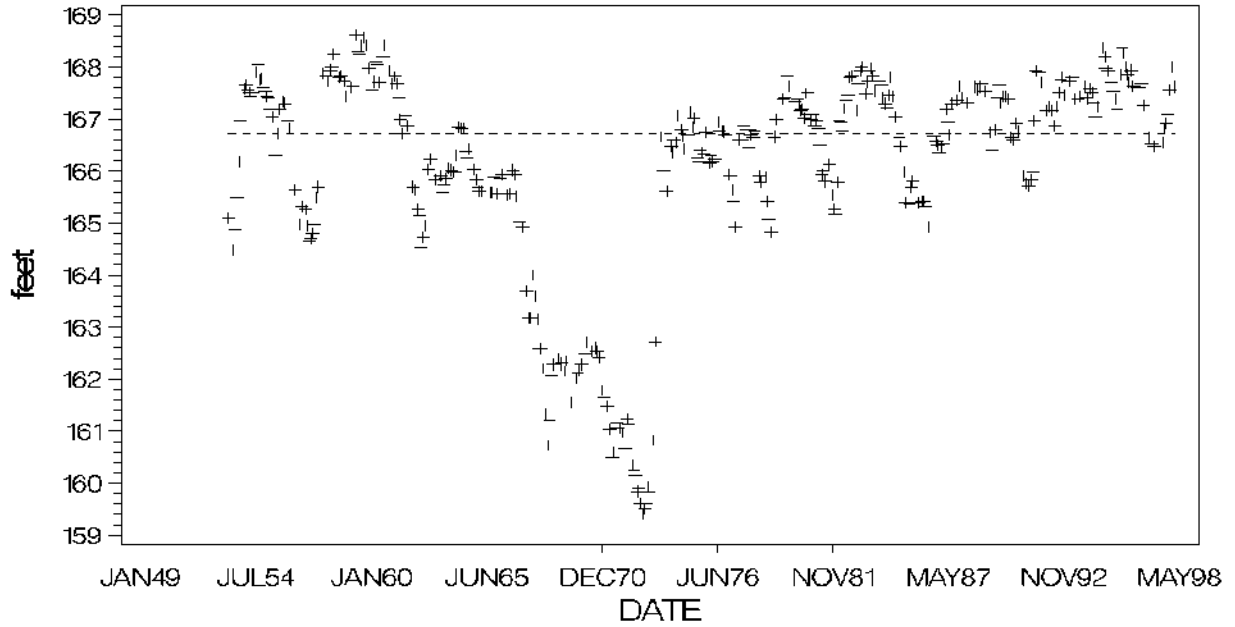

MAJOR IONS (% meq/l)

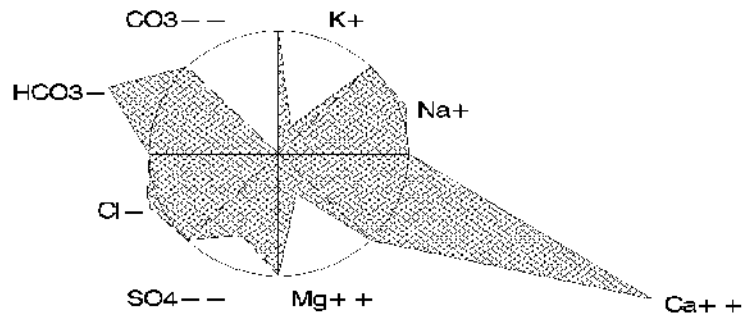

Lake Buffum

Polk County

USGS Quadrangle: Alturas Major Land Use/Land Cover (1990)
 Section/Township/Range: 12-31S-26E within 500 meters of the lakeshore:
 Approx. Lake Center, Lat/Long: 274753/813952 - cropland and pastureland (26%)
 Surface Area: 1543 acres - stream and lake swamps (20%)
 Approx. Lake Elevation: 132 feet - tree crops, typically citrus (19%)
 Observed Maximum Depth: 22 feet
 (reference elevation not given)
 Lake Type: outflow (type 2)
 Major Basin: Peace River
 Minor Basin: Bowlegs Creek
 Lake Region: Lake Wales Ridge Transition
 Public Access: yes

Total Number of Samples Collected: 2 Most Recent Sample Collected: December 1996

Parameter	Units (Detection Limit)	Average Value	District Percentile	Florida Percentile
Chlorophyll a	ug/l (1)	10.8	67	40
Total Phosphorus	mg/l as P (0.01)	0.018	61	9
Total Nitrogen	mg/l as N (0.06)	0.72	19	21
Transparency (Secchi depth)	meters	0.93	30	61
Florida Trophic State Index		38	50	13
Specific Conductance	S/cm at 25C (1)	150	39	42
pH	standard units (0.1)	6.2	8	10
Color	PtCo units (1)	40	72	30
Turbidity	NTU (1)	5.4	75	52
Total Alkalinity	mg/l as CaCO3 (1)	2	<5	5
Hardness	mg/l as CaCO3 (0.02)	32	25	
Total Suspended Solids	mg/l (0.05)	3.1	64	
Ammonia	mg/l as N (0.03)	0.015	60	
Nitrate+Nitrite	mg/l as N (0.01)	0.005	33	
Total Kjeldahl Nitrogen	mg/l as N (0.06)	0.72	25	
Orthophosphorus	mg/l as P (0.01)	0.012	68	
Chloride	mg/l (0.05)	26	78	
Sulfate	mg/l (0.05)	20	61	
Sodium	mg/l (0.06)	11.4	65	
Potassium	mg/l (0.07)	5.3	68	
Calcium	mg/l (0.04)	4.3	10	
Magnesium	mg/l (0.006)	5.1	70	
Iron	ug/l (0.03)	120	85	

Based upon the average FTSI of 38, water quality is considered good. Lake Buffum can be characterized as a colored, soft water, eutrophic lake, with low concentrations of total nitrogen. The chemical type of water (predominant ionic composition) is sodium chloride.

Also of note:

- Melaleuca was observed on the lake shore.

Plots and Trends: There is no apparent trend in either lake elevation or specific conductance. The range in lake level fluctuation is approximately 8 feet for the period of record. Also shown is a diagram of the relative ionic composition of the lake water.

MONTHLY AVERAGE SURFACE ELEVATION

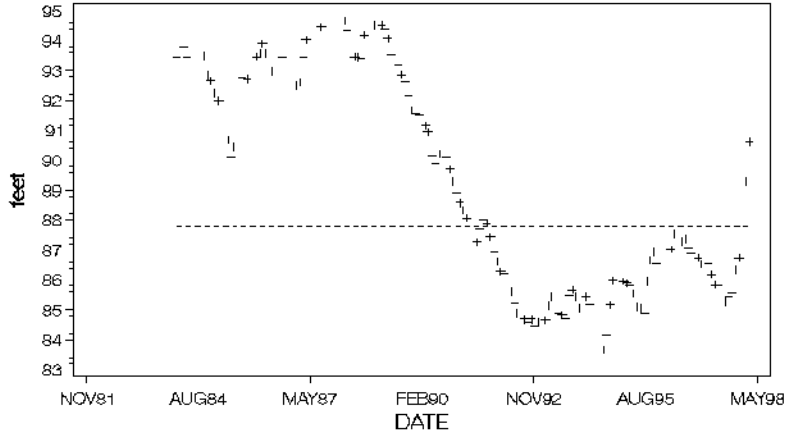

SPEC. CONDUCTANCE

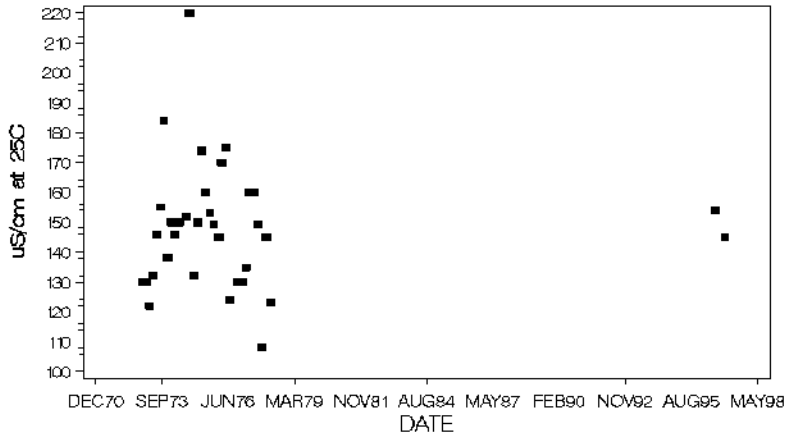

MAJOR IONS (% meq/l)

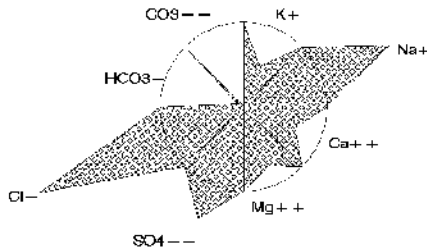

Lake Cannon

Polk County

USGS Quadrangle: Auburndale Major Land Use/Land Cover (1990)
 Section/Township/Range: 19-28S-26E within 500 meters of the lakeshore:
 Approx. Lake Center, Lat/Long: 280219/814511 - medium density residential (70%)
 Surface Area: 336 acres - commercial and services (8%)
 Approx. Lake Elevation: 132 feet - institutional (8%)
 Average Depth: 11.2 feet
 Observed Maximum Depth: 16 feet
 (reference elevation 130 feet)
 Lake Type: inflow and outflow (type 3)
 Major Basin: Peace River
 Minor Basin: Lake Lulu Outlet
 Lake Region: Winter Haven/Lake Henry Ridges
 Public Access: yes

Total Number of Samples Collected: 2 Most Recent Sample Collected: February 1997

Parameter	Units (Detection Limit)	Average Value	District Percentile	Florida Percentile
Chlorophyll a	ug/l (1)	32.5	87	68
Total Phosphorus	mg/l as P (0.01)	0.032	79	22
Total Nitrogen	mg/l as N (0.06)	1.70	75	70
Transparency (Secchi depth)	meters	0.73	19	43
Florida Trophic State Index		64	88	63
Specific Conductance	S/cm at 25C (1)	193	56	51
pH	standard units (0.1)	8.6	92	85
Color	PtCo units (1)	13	41	12
Turbidity	NTU (1)	7.0	82	60
Total Alkalinity	mg/l as CaCO3 (1)	62	87	69
Hardness	mg/l as CaCO3 (0.02)	75	75	
Total Suspended Solids	mg/l (0.05)	6.0	82	
Ammonia	mg/l as N (0.03)	0.015	60	
Nitrate+Nitrite	mg/l as N (0.01)	0.005	33	
Total Kjeldahl Nitrogen	mg/l as N (0.06)	1.70	83	
Orthophosphorus	mg/l as P (0.01)	0.008	56	
Chloride	mg/l (0.05)	18	46	
Sulfate	mg/l (0.05)	20	61	
Sodium	mg/l (0.06)	13.0	76	
Potassium	mg/l (0.07)	4.6	62	
Calcium	mg/l (0.04)	22.5	82	
Magnesium	mg/l (0.006)	4.4	61	
Iron	ug/l (0.03)	32	42	

Based upon the average FTSI of 64, water quality is considered fair. Lake Cannon can be characterized as a clear to moderately colored (color<20 color units), medium hard water, eutrophic to hypereutrophic lake. The chemical type of water (predominant ionic composition) is calcium bicarbonate.

Also of note:

- The measured pH was high.

Plots and Trends: The plots for Lake Canon show that water quality has been relatively stable over the 30 year period of record. Also shown is a diagram of the relative ionic composition of the lake water.

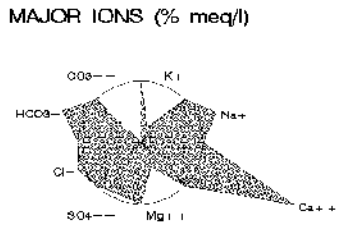
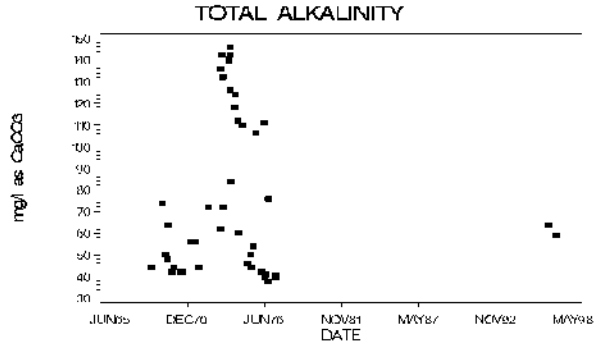
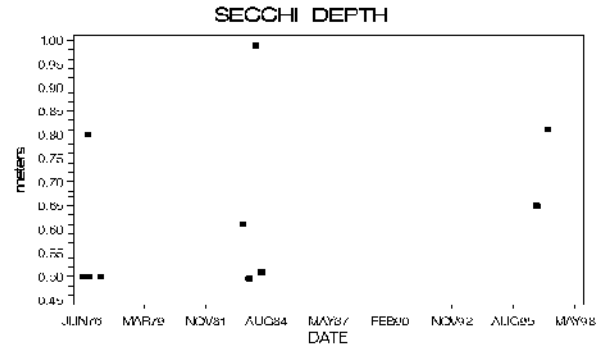
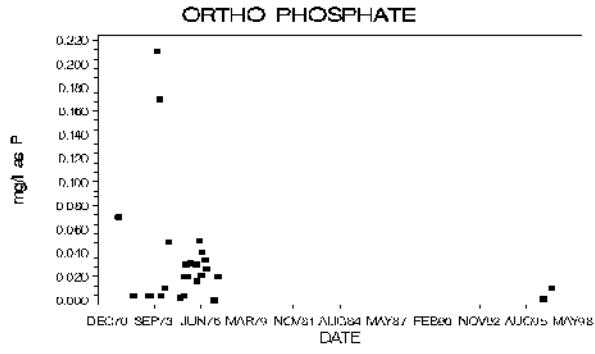
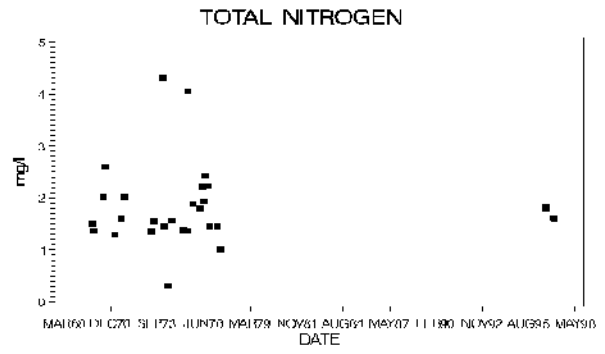
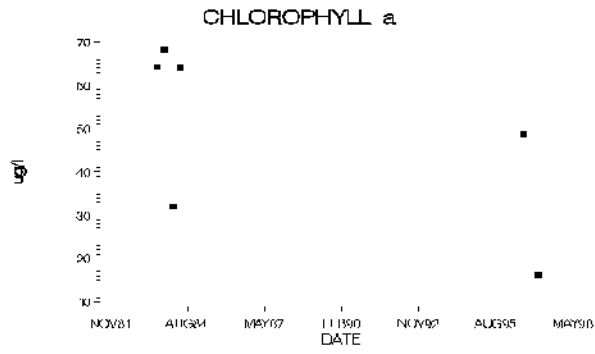
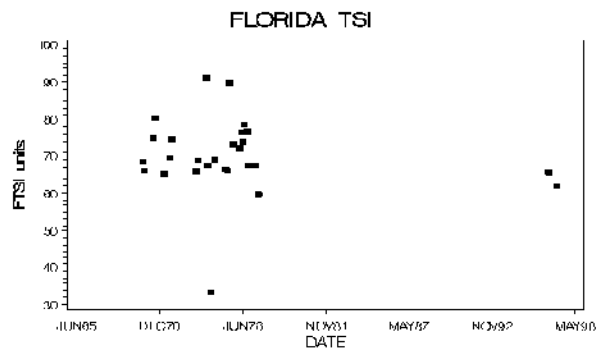
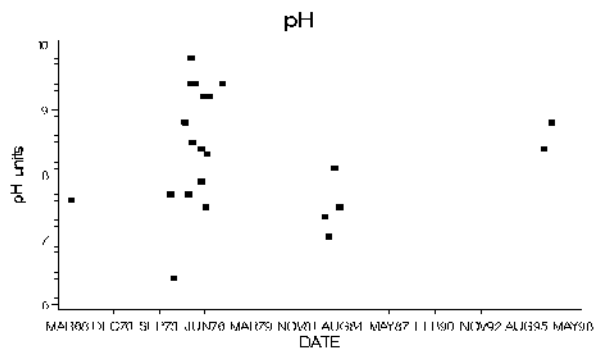

Lake Cannon, Polk County

Lake Clinch Polk County

USGS Quadrangle: Frostproof Major Land Use/Land Cover (1990)
 Section/Township/Range: 31-31S-28E within 500 meters of the lakeshore:
 Approx. Lake Center, Lat/Long: 274440/813256 - tree crops, typically citrus (27%)
 Surface Area: 1207 acres - medium density residential (27%)
 Approx. Lake Elevation: 107 feet - low density residential (17%)
 Average Depth: 17.5 feet
 Observed Maximum Depth: 36 feet
 (reference elevation not given)
 Lake Type: inflow and outflow (type 3)
 Major Basin: Kissimmee Ridge
 Minor Basin: Clinch-Reedy Canal
 Lake Region: Northern Lake Wales Ridge
 Public Access: yes

Total Number of Samples Collected: 2 Most Recent Sample Collected: January 1997

Parameter	Units (Detection Limit)	Average Value	District Percentile	Florida Percentile
Chlorophyll a	ug/l (1)	8.6	59	34
Total Phosphorus	mg/l as P (0.01)	0.005	31	<5
Total Nitrogen	mg/l as N (0.06)	0.66	15	18
Transparency (Secchi depth)	meters	2.13	69	87
Florida Trophic State Index		33	36	8
Specific Conductance	S/cm at 25C (1)	135	28	37
pH	standard units (0.1)	8.4	90	80
Color	PtCo units (1)	10	34	10
Turbidity	NTU (1)	1.6	44	14
Total Alkalinity	mg/l as CaCO3 (1)	6	15	17
Hardness	mg/l as CaCO3 (0.02)	30	21	
Total Suspended Solids	mg/l (0.05)	6.4	84	
Ammonia	mg/l as N (0.03)	0.033	64	
Nitrate+Nitrite	mg/l as N (0.01)	0.009	33	
Total Kjeldahl Nitrogen	mg/l as N (0.06)	0.65	20	
Orthophosphorus	mg/l as P (0.01)	0.009	56	
Chloride	mg/l (0.05)	18	46	
Sulfate	mg/l (0.05)	22	65	
Sodium	mg/l (0.06)	9.6	56	
Potassium	mg/l (0.07)	5.4	69	
Calcium	mg/l (0.04)	4.6	12	
Magnesium	mg/l (0.006)	4.5	63	
Iron	ug/l (0.03)	19	18	

Based upon the average FTSI of 33, water quality is considered good. Lake Clinch can be characterized as a clear (color<=10 color units), soft water, eutrophic lake, with low concentrations of total phosphorus, low concentrations of total nitrogen. The chemical type of water (predominant ionic composition) is sodium chloride.

Also of note:

- The measured pH was high.

Plots and Trends: Similar to plots of lake elevation for other lakes in the Lake Wales Ridge region, Lake Clinch surface elevations have generally increased during the 1990s, recovering from the drought years in the mid- to late 1980s in the Lake Wales Ridge region. Also shown is a diagram of the relative ionic composition of the lake water.

MONTHLY AVERAGE SURFACE ELEVATION

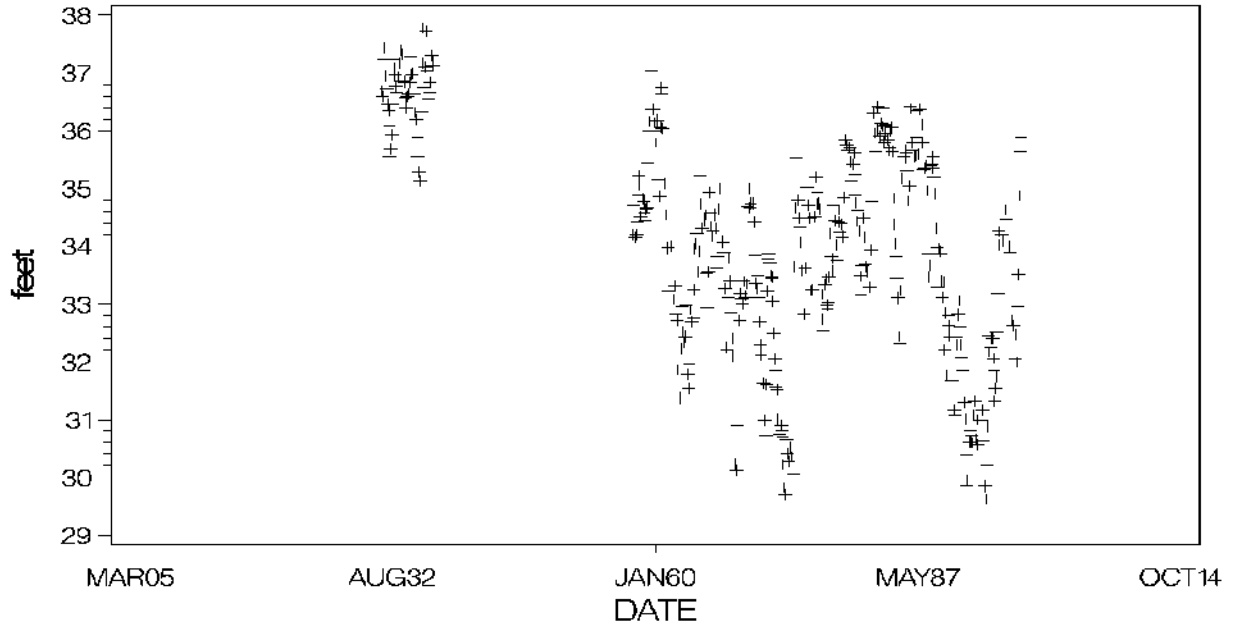

MAJOR IONS (% meq/l)

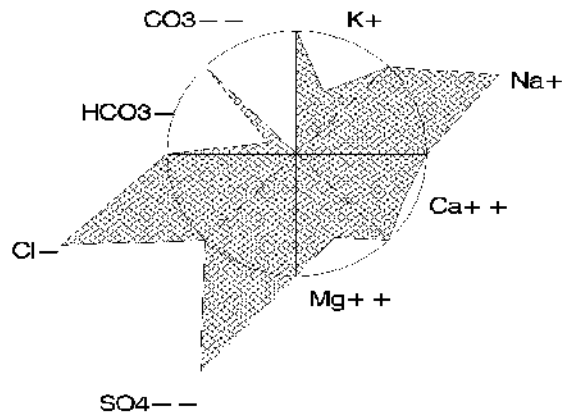

Lake Conine

Polk County

USGS Quadrangle: Winter Haven Major Land Use/Land Cover (1990)
 Section/Township/Range: 9-28S-26E within 500 meters of the lakeshore:
 Approx. Lake Center, Lat/Long: 280335/814330 - medium density residential (29%)
 Surface Area: 236 acres - tree crops, typically citrus (21%)
 Approx. Lake Elevation: 129 feet - commercial and services (17%)
 Average Depth: 10.6 feet
 Observed Maximum Depth: 16 feet
 (reference elevation 128.3 feet)
 Lake Type: inflow and outflow (type 3)
 Major Basin: Peace River
 Minor Basin: Lake Fannie Outlet
 Lake Region: Winter Haven/Lake Henry Ridges
 Public Access: yes

Total Number of Samples Collected: 2 Most Recent Sample Collected: February 1997

Parameter	Units (Detection Limit)	Average Value	District Percentile	Florida Percentile
Chlorophyll a	ug/l (1)	82.0	>95	93
Total Phosphorus	mg/l as P (0.01)	0.048	86	39
Total Nitrogen	mg/l as N (0.06)	1.54	70	62
Transparency (Secchi depth)	meters	0.47	6	16
Florida Trophic State Index		73	>95	87
Specific Conductance	S/cm at 25C (1)	189	55	50
pH	standard units (0.1)	9.1	>95	94
Color	PtCo units (1)	25	62	20
Turbidity	NTU (1)	18.3	>95	80
Total Alkalinity	mg/l as CaCO3 (1)	64	89	70
Hardness	mg/l as CaCO3 (0.02)	67	70	
Total Suspended Solids	mg/l (0.05)	17.3	>95	
Ammonia	mg/l as N (0.03)	0.015	60	
Nitrate+Nitrite	mg/l as N (0.01)	0.005	33	
Total Kjeldahl Nitrogen	mg/l as N (0.06)	1.54	78	
Orthophosphorus	mg/l as P (0.01)	0.012	68	
Chloride	mg/l (0.05)	23	69	
Sulfate	mg/l (0.05)	12	41	
Sodium	mg/l (0.06)	15.0	83	
Potassium	mg/l (0.07)	7.7	85	
Calcium	mg/l (0.04)	17.0	65	
Magnesium	mg/l (0.006)	5.9	75	
Iron	ug/l (0.03)	19	17	

Based upon the average FTSI of 73, water quality is considered poor. Lake Conine can be characterized as a moderately colored, medium hard water, hypereutrophic lake, with high concentrations of total phosphorus. The chemical type of water is calcium chloride.

Also of note:

- The measured pH was very high.
- Cattails dominate more than 30% of the lake shoreline.

Plots and Trends: Concentrations of orthophosphate were very high during the 1970s when the lake received Winter Haven treated effluent. The effluent was diverted from the lake in 1992. Also, in 1994 alum was used in the lake as part of a project to test its effectiveness for reducing phosphorus. The orthophosphate samples collected in 1995 are probably reflective of these actions. Other measures of water chemistry have remained stable over the period of record. Also shown is a diagram of the relative ionic composition of the lake water.

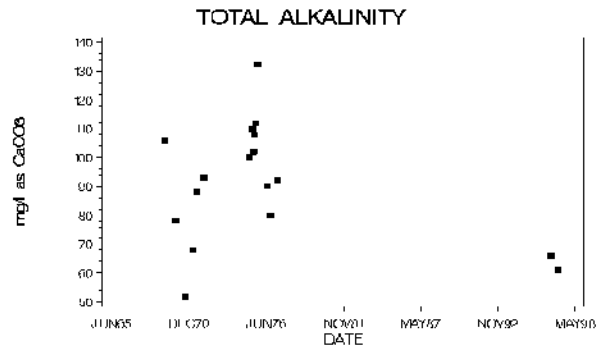
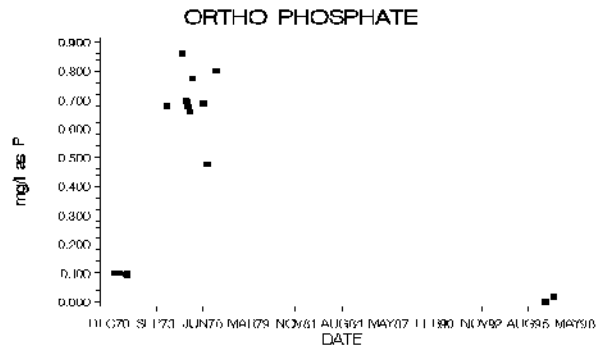
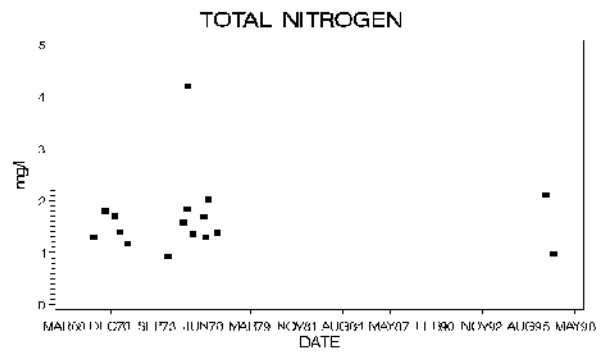
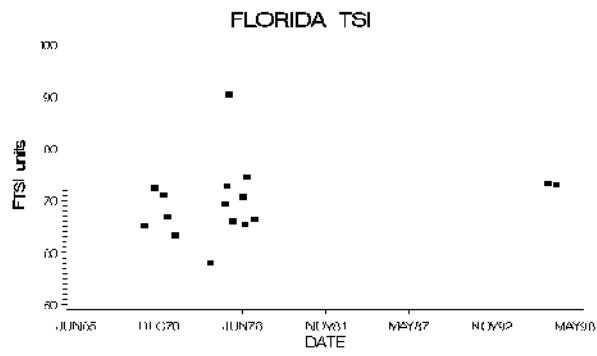

MAJOR IONS (% meq/l)

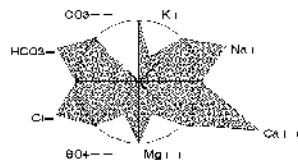

Crooked Lake

Polk County

USGS Quadrangle: Babson Park Major Land Use/Land Cover (1990)
 Section/Township/Range: 1-31S-27E within 500 meters of the lakeshore:
 Approx. Lake Center, Lat/Long: 274906/813349 - herbaceous range (24%)
 Surface Area: 4693 acres - tree crops, typically citrus (19%)
 Approx. Lake Elevation: 122 feet - wet prairies (12%)
 Average Depth: 8.3 feet
 Observed Maximum Depth: 25 feet
 (reference elevation not given)
 Lake Type: inflow and outflow (type 3)
 Major Basin: Kissimmee Ridge
 Minor Basin: Crooked Lake Outlet
 Lake Region: Northern Lake Wales Ridge
 Public Access: yes

Total Number of Samples Collected: 2 Most Recent Sample Collected: January 1997

Parameter	Units (Detection Limit)	Average Value	District Percentile	Florida Percentile
Chlorophyll a	ug/l (1)	3.7	33	15
Total Phosphorus	mg/l as P (0.01)	0.005	31	<5
Total Nitrogen	mg/l as N (0.06)	0.44	<5	7
Transparency (Secchi depth)	meters	2.98	83	>95
Florida Trophic State Index		25	15	<5
Specific Conductance	S/cm at 25C (1)	83	9	16
pH	standard units (0.1)	7.1	38	35
Color	PtCo units (1)	13	41	12
Turbidity	NTU (1)	0.8	28	<5
Total Alkalinity	mg/l as CaCO3 (1)	3	7	8
Hardness	mg/l as CaCO3 (0.02)	17	7	
Total Suspended Solids	mg/l (0.05)	0.8	21	
Ammonia	mg/l as N (0.03)	0.015	60	
Nitrate+Nitrite	mg/l as N (0.01)	0.017	46	
Total Kjeldahl Nitrogen	mg/l as N (0.06)	0.43	5	
Orthophosphorus	mg/l as P (0.01)	0.005	56	
Chloride	mg/l (0.05)	14	30	
Sulfate	mg/l (0.05)	8	31	
Sodium	mg/l (0.06)	8.1	45	
Potassium	mg/l (0.07)	1.5	25	
Calcium	mg/l (0.04)	2.7	5	
Magnesium	mg/l (0.006)	2.4	35	
Iron	ug/l (0.03)	42	54	

Based upon the average FTSI of 25, water quality is considered good. Crooked Lake can be characterized as a clear to moderately colored (10 < color < 20 units), soft water, oligo-mesotrophic lake, with low concentrations of total phosphorus and very low concentrations of total nitrogen. The chemical type of water (predominant ionic composition) is sodium chloride.

Plots and Trends: Lake surface elevation in Crooked Lake declined steadily from the late 1960s until about 1990. As seen in other lakes in the Lake Wales Ridge region, lake levels rebounded through the 1990s to near historical levels. The plots show that measures of water chemistry have been relatively stable over the period of record. Recent samples of the water chemistry variables shown are within their ranges of variability over the period of record, and no trends are evident. Also shown is a diagram of the relative ionic composition of the lake water.

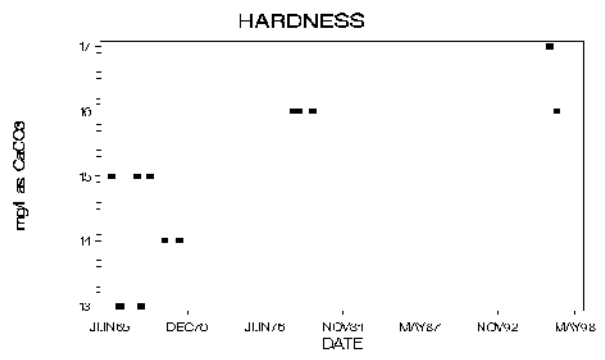
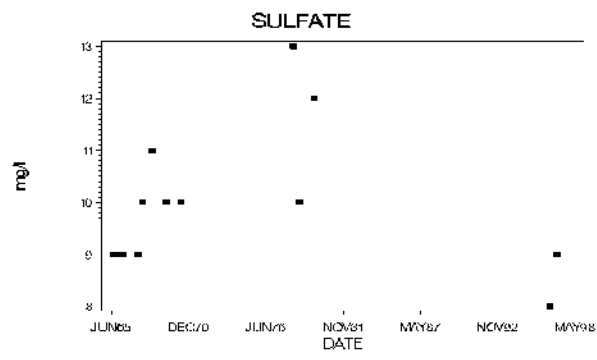
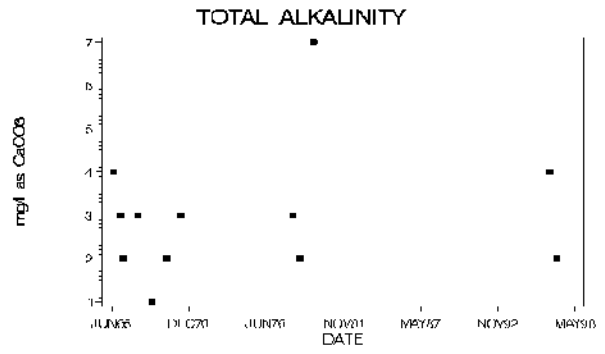
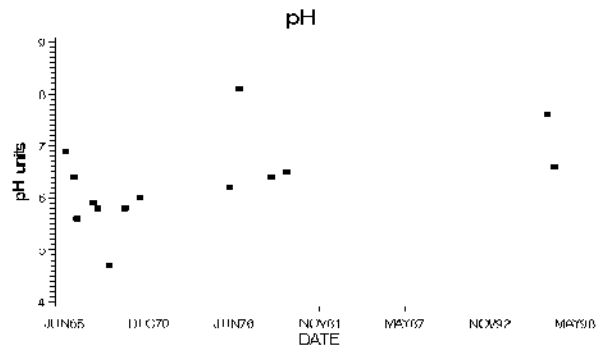
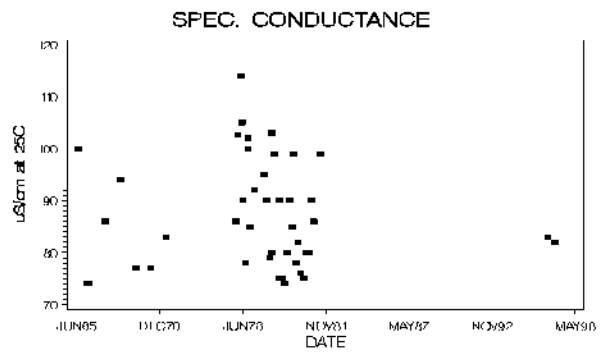
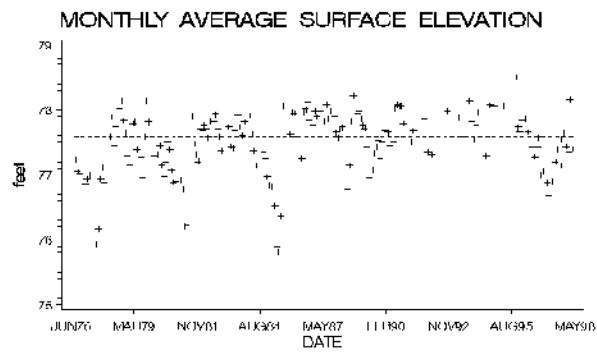

MAJOR IONS (% meq/l)

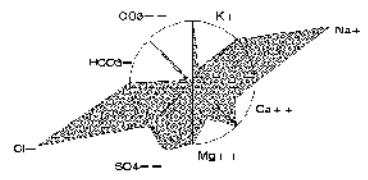

Crooked Lake, Polk County

Cypress Lake

Polk County

USGS Quadrangle: Hesperides Major Land Use/Land Cover (1990)
 Section/Township/Range: 36-29S-28E within 500 meters of the lakeshore:
 Approx. Lake Center, Lat/Long: 275451/812847 - tree crops, typically citrus (92%)
 Surface Area: 71 acres - low density residential (5%)
 Approx. Lake Elevation: 99 feet - stream and lake swamps (2%)
 Average Depth: 12.8 feet
 Observed Maximum Depth: 29 feet
 (reference elevation 92.1 feet)
 Lake Type: inflow and outflow (type 3)
 Major Basin: Kissimmee Ridge
 Minor Basin: Lake Pierce
 Lake Region: Northern Lake Wales Ridge

Total Number of Samples Collected: 2 Most Recent Sample Collected: January 1996

Parameter	Units (Detection Limit)	Average Value	District Percentile	Florida Percentile
Chlorophyll a	ug/l (1)	1.6	7	6
Total Phosphorus	mg/l as P (0.01)	0.013	46	7
Total Nitrogen	mg/l as N (0.06)	1.78	78	74
Transparency (Secchi depth)	meters	3.00	84	>95
Florida Trophic State Index		25	14	<5
Specific Conductance	S/cm at 25C (1)	266	83	63
pH	standard units (0.1)	8.3	87	78
Color	PtCo units (1)	5	9	5
Turbidity	NTU (1)	0.5	28	<5
Total Alkalinity	mg/l as CaCO3 (1)	46	77	60
Hardness	mg/l as CaCO3 (0.02)	94	89	
Total Suspended Solids	mg/l (0.05)	0.0	<5	
Ammonia	mg/l as N (0.03)	0.140	93	
Nitrate+Nitrite	mg/l as N (0.01)	0.647	93	
Total Kjeldahl Nitrogen	mg/l as N (0.06)	1.13	58	
Orthophosphorus	mg/l as P (0.01)	0.011	64	
Chloride	mg/l (0.05)	25	76	
Sulfate	mg/l (0.05)	33	82	
Sodium	mg/l (0.06)	6.9	32	
Potassium	mg/l (0.07)	12.5	93	
Calcium	mg/l (0.04)	18.5	71	
Magnesium	mg/l (0.006)	11.5	91	
Iron	ug/l (0.03)	25	31	

Based upon the average FTSI of 25, water quality is considered good. Cypress Lake can be characterized as a clear (color<=10 color units), medium hard water, oligotrophic lake. The chemical type of water (predominant ionic composition) is calcium chloride (1 sample) or calcium sulfate (1 sample).

Also of note:

- The measured pH was high.

Plots and Trends: Similar to plots of lake elevation for other lakes in the Lake Wales Ridge region, Cypress Lake surface elevations have generally increased during the 1990s, recovering from the drought years in the mid- to late 1980s in the Lake Wales Ridge region. Also shown is a diagram of the relative ionic composition of the lake water.

MONTHLY AVERAGE SURFACE ELEVATION

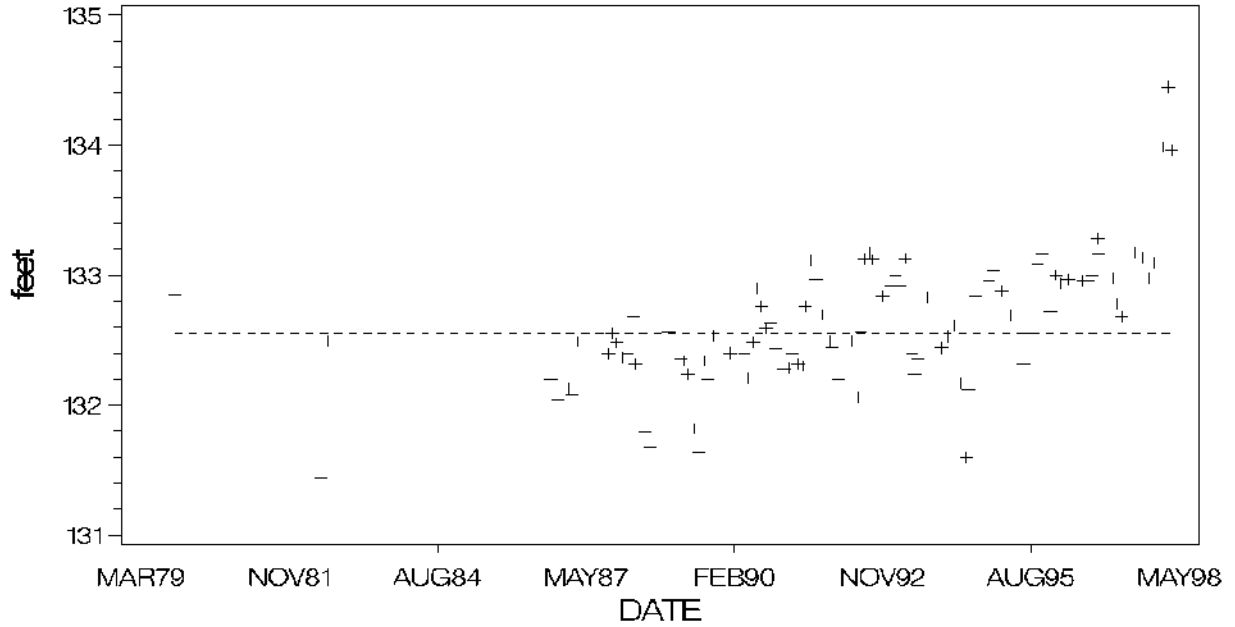

MAJOR IONS (% meq/l)

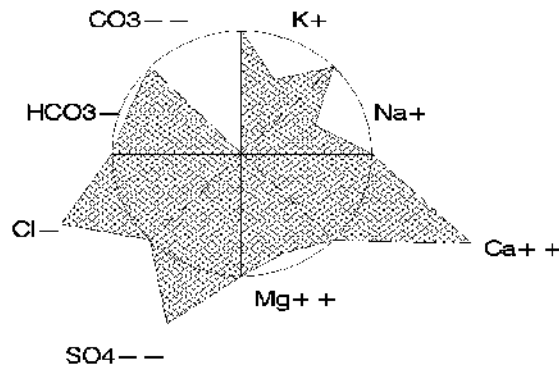

Lake Daisy

Polk County

USGS Quadrangle: Eloise Major Land Use/Land Cover (1990)
 Section/Township/Range: 6-29S-27E within 500 meters of the lakeshore:
 Approx. Lake Center, Lat/Long: 275948/813934 - medium density residential (37%)
 Surface Area: 133 acres - tree crops, typically citrus (25%)
 Approx. Lake Elevation: 130 feet - open land (16%)
 Average Depth: 10.7 feet
 Observed Maximum Depth: 16 feet
 (reference elevation 128.4 feet)
 Lake Type: inflow (type 1)
 Major Basin: Peace River
 Minor Basin: Peace Creek Dr Canal
 Lake Region: Winter Haven/Lake Henry Ridges
 Public Access: yes

Total Number of Samples Collected: 2 Most Recent Sample Collected: February 1997

Parameter	Units (Detection Limit)	Average Value	District Percentile	Florida Percentile
Chlorophyll a	ug/l (1)	3.7	33	15
Total Phosphorus	mg/l as P (0.01)	0.008	31	<5
Total Nitrogen	mg/l as N (0.06)	0.37	<5	<5
Transparency (Secchi depth)	meters	2.51	76	92
Florida Trophic State Index		30	28	5
Specific Conductance	S/cm at 25C (1)	163	43	45
pH	standard units (0.1)	6.4	12	15
Color	PtCo units (1)	13	41	12
Turbidity	NTU (1)	1.2	34	8
Total Alkalinity	mg/l as CaCO3 (1)	4	10	10
Hardness	mg/l as CaCO3 (0.02)	37	30	
Total Suspended Solids	mg/l (0.05)	0.9	24	
Ammonia	mg/l as N (0.03)	0.015	60	
Nitrate+Nitrite	mg/l as N (0.01)	0.005	33	
Total Kjeldahl Nitrogen	mg/l as N (0.06)	0.37	<5	
Orthophosphorus	mg/l as P (0.01)	0.013	72	
Chloride	mg/l (0.05)	21	61	
Sulfate	mg/l (0.05)	33	82	
Sodium	mg/l (0.06)	12.0	69	
Potassium	mg/l (0.07)	4.2	58	
Calcium	mg/l (0.04)	3.1	6	
Magnesium	mg/l (0.006)	7.3	81	
Iron	ug/l (0.03)	25	30	

Based upon the average FTSI of 30, water quality is considered good. Lake Daisy can be characterized as a clear to moderately colored (10<color<20 color units), soft water, oligo-mesotrophic lake, with low concentrations of total phosphorus, very low concentrations of total nitrogen. The chemical type of water (predominant ionic composition) is sodium sulfate.

Also of note:

- Cattails dominate more than 30% of the lake shoreline.

Plots and Trends: No or insufficient data for plotting or trend detection. Shown is a diagram of the relative ionic composition of the lake water.

MAJOR IONS (% meq/l)

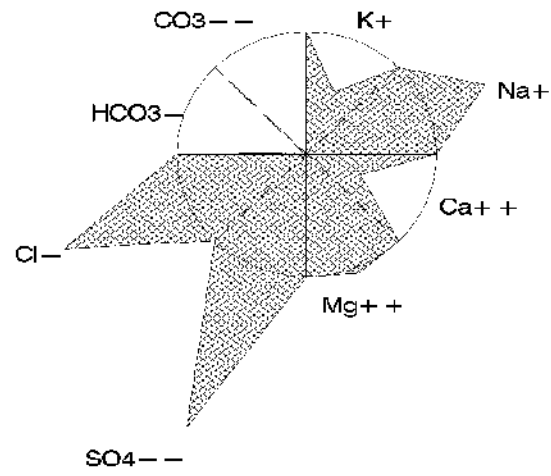

Lake Davenport

Polk County

USGS Quadrangle: Davenport Major Land Use/Land Cover (1990)
 Section/Township/Range: 4-27S-27E within 500 meters of the lakeshore:
 Approx. Lake Center, Lat/Long: 280935/813637 - tree crops, typically citrus (23%)
 Surface Area: 65 acres - low density residential (18%)
 Approx. Lake Elevation: 114 feet - other open lands - rural (18%)
 Lake Type: isolated (type 4)
 Major Basin: Kissimmee Ridge
 Minor Basin: Horse Creek
 Lake Region: Northern Lake Wales Ridge

Total Number of Samples Collected: 2 Most Recent Sample Collected: January 1996

Parameter	Units (Detection Limit)	Average Value	District Percentile	Florida Percentile
Chlorophyll a	ug/l (1)	1.5	5	5
Total Phosphorus	mg/l as P (0.01)	0.010	33	5
Total Nitrogen	mg/l as N (0.06)	1.43	68	53
Transparency (Secchi depth)	meters	1.10	38	67
Florida Trophic State Index		24	12	<5
Specific Conductance	S/cm at 25C (1)	68	<5	11
pH	standard units (0.1)	6.6	18	20
Color	PtCo units (1)	60	82	50
Turbidity	NTU (1)	0.5	28	<5
Total Alkalinity	mg/l as CaCO3 (1)	11	29	27
Hardness	mg/l as CaCO3 (0.02)	23	12	
Total Suspended Solids	mg/l (0.05)	0.5	11	
Ammonia	mg/l as N (0.03)	0.047	73	
Nitrate+Nitrite	mg/l as N (0.01)	0.005	33	
Total Kjeldahl Nitrogen	mg/l as N (0.06)	1.43	76	
Orthophosphorus	mg/l as P (0.01)	0.008	56	
Chloride	mg/l (0.05)	8	9	
Sulfate	mg/l (0.05)	19	58	
Sodium	mg/l (0.06)	4.2	10	
Potassium	mg/l (0.07)	2.0	34	
Calcium	mg/l (0.04)	4.9	14	
Magnesium	mg/l (0.006)	2.5	36	
Iron	ug/l (0.03)	73	72	

Based upon the average FTSI of 24, water quality is considered good. Lake Davenport can be characterized as a colored, soft water, oligotrophic lake. The chemical type of water (predominant ionic composition) is calcium chloride (2 samples) or calcium sulfate (1 sample).

Plots and Trends: No or insufficient data for plotting or trend detection. Also shown is a diagram of the relative ionic composition of the lake water.

MAJOR IONS (% meq/l)

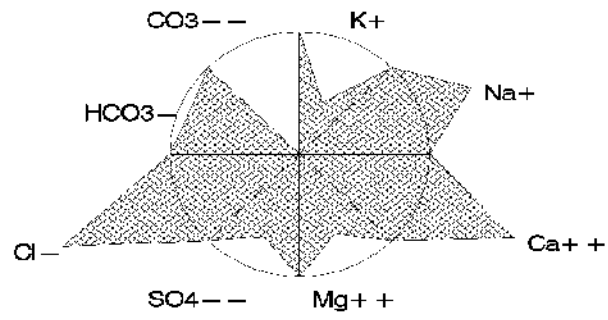

Lake Deeson

Polk County

USGS Quadrangle: Lakeland Major Land Use/Land Cover (1990)
 Section/Township/Range: 29-27S-24E within 500 meters of the lakeshore:
 Approx. Lake Center, Lat/Long: 280644/815550 - medium density residential (41%)
 Surface Area: 117 acres - commercial and services (11%)
 Approx. Lake Elevation: 124 feet - low density residential (11%)
 Observed Maximum Depth: 12.5 feet
 (reference elevation not given)
 Lake Type: isolated (type 4)
 Major Basin: Withlacoochee River
 Minor Basin: Orange Hammock Drain
 Lake Region: Lakeland/Bone Valley Upland
 Public Access: yes

Total Number of Samples Collected: 2 Most Recent Sample Collected: January 1997

Parameter	Units (Detection Limit)	Average Value	District Percentile	Florida Percentile
Chlorophyll a	ug/l (1)	17.3	76	48
Total Phosphorus	mg/l as P (0.01)	0.020	65	10
Total Nitrogen	mg/l as N (0.06)	0.91	33	30
Transparency (Secchi depth)	meters	1.27	43	71
Florida Trophic State Index		46	65	27
Specific Conductance	S/cm at 25C (1)	122	21	32
pH	standard units (0.1)	7.7	69	60
Color	PtCo units (1)	25	62	20
Turbidity	NTU (1)	2.2	54	23
Total Alkalinity	mg/l as CaCO3 (1)	32	62	51
Hardness	mg/l as CaCO3 (0.02)	41	38	
Total Suspended Solids	mg/l (0.05)	2.2	55	
Ammonia	mg/l as N (0.03)	0.015	60	
Nitrate+Nitrite	mg/l as N (0.01)	0.005	33	
Total Kjeldahl Nitrogen	mg/l as N (0.06)	0.91	39	
Orthophosphorus	mg/l as P (0.01)	0.005	56	
Chloride	mg/l (0.05)	13	27	
Sulfate	mg/l (0.05)	8	31	
Sodium	mg/l (0.06)	7.0	33	
Potassium	mg/l (0.07)	1.8	30	
Calcium	mg/l (0.04)	13.0	53	
Magnesium	mg/l (0.006)	2.2	31	
Iron	ug/l (0.03)	37	49	

Based upon the average FTSI of 46, water quality is considered good. Lake Deeson can be characterized as a moderately colored, soft water, eutrophic lake. The chemical type of water (predominant ionic composition) is calcium bicarbonate (1 sample) or calcium chloride.

Also of note:

- Hydrilla was observed in the lake.

Plots and Trends: Lake surface elevations in Lake Deeson were greater during the mid-1950s until the early 1960s when the period of record was interrupted. When lake level record collection resumed in 1965 the surface elevations in Lake Deeson had declined by 8 to 10 feet from the earlier levels, and remained lower until the early 1990s. The low lake levels may be due to groundwater pumping for mining operations in the vicinity of Lake Parker, which ceased in the late 1970s and early 1980s. Also shown is a diagram of the relative ionic composition of the lake water.

MONTHLY AVERAGE SURFACE ELEVATION

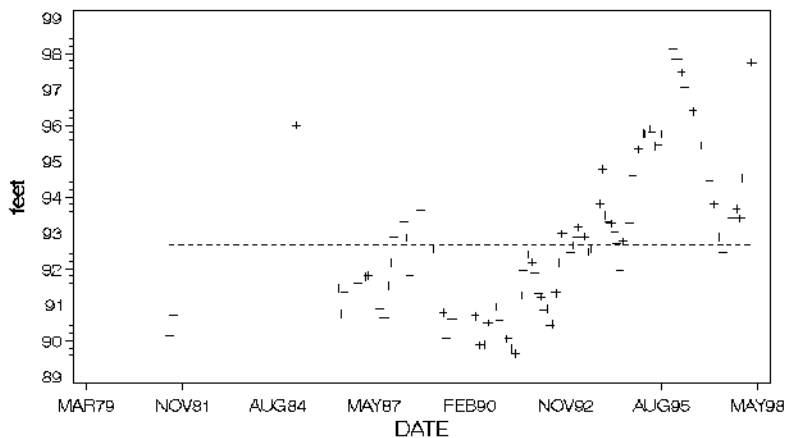

SPEC. CONDUCTANCE

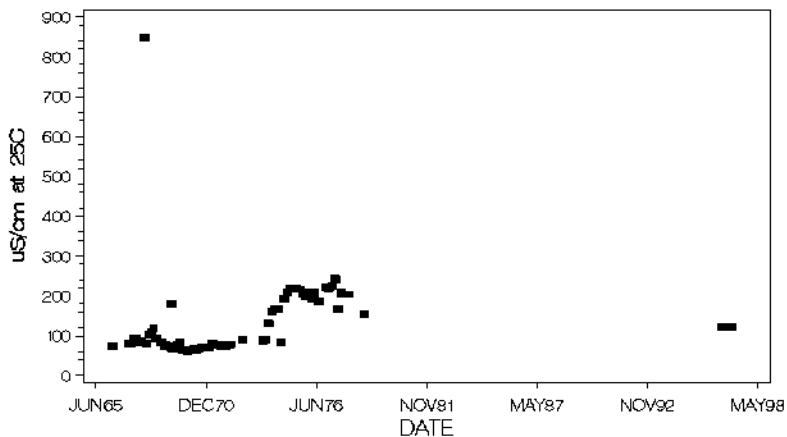

MAJOR IONS (% meq/l)

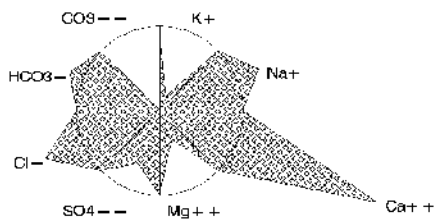

Eagle Lake

Polk County

USGS Quadrangle: Bartow
 Section/Township/Range: 1-29S-25E
 Approx. Lake Center, Lat/Long: 275908/814553
 Surface Area: 651 acres
 Approx. Lake Elevation: 131 feet
 Average Depth: 15.1 feet
 (reference elevation 125 feet)
 Lake Type: outflow (type 2)
 Major Basin: Peace River
 Minor Basin: Saddle Creek
 Lake Region: Winter Haven/Lake Henry Ridges
 Public Access: yes

Major Land Use/Land Cover (1990)
 within 500 meters of the lakeshore:
 - medium density residential (44%)
 - tree crops, typically citrus (26%)
 - freshwater marshes (9%)

Total Number of Samples Collected: 2 Most Recent Sample Collected: January 1997

Parameter	Units (Detection Limit)	Average Value	District Percentile	Florida Percentile
Chlorophyll a	ug/l (1)	9.3	61	36
Total Phosphorus	mg/l as P (0.01)	0.020	65	10
Total Nitrogen	mg/l as N (0.06)	1.20	55	40
Transparency (Secchi depth)	meters	2.11	68	87
Florida Trophic State Index		43	58	20
Specific Conductance	S/cm at 25C (1)	276	85	65
pH	standard units (0.1)	7.9	78	67
Color	PtCo units (1)	5	9	5
Turbidity	NTU (1)	2.0	51	20
Total Alkalinity	mg/l as CaCO3 (1)	31	60	50
Hardness	mg/l as CaCO3 (0.02)	80	80	
Total Suspended Solids	mg/l (0.05)	1.6	42	
Ammonia	mg/l as N (0.03)	0.015	60	
Nitrate+Nitrite	mg/l as N (0.01)	0.039	64	
Total Kjeldahl Nitrogen	mg/l as N (0.06)	1.17	60	
Orthophosphorus	mg/l as P (0.01)	0.011	64	
Chloride	mg/l (0.05)	27	80	
Sulfate	mg/l (0.05)	55	95	
Sodium	mg/l (0.06)	14.0	80	
Potassium	mg/l (0.07)	10.0	90	
Calcium	mg/l (0.04)	14.0	56	
Magnesium	mg/l (0.006)	11.0	90	
Iron	ug/l (0.03)	32	42	

Based upon the average FTSI of 43, water quality is considered good. Eagle Lake can be characterized as a clear (color<=10 color units), medium hard water, meso-eutrophic lake. The chemical type of water (predominant ionic composition) is calcium sulfate.

Also of note:

- Melaleuca was observed on the lake shore.

Plots and Trends: Similar to plots of lake elevation for other lakes in the Lake Wales Ridge region, Eagle Lake surface elevations have generally increased during the 1990s, recovering from the drought years in the mid- to late 1980s in the Lake Wales Ridge region. Also shown is a diagram of the relative ionic composition of the lake water.

MONTHLY AVERAGE SURFACE ELEVATION

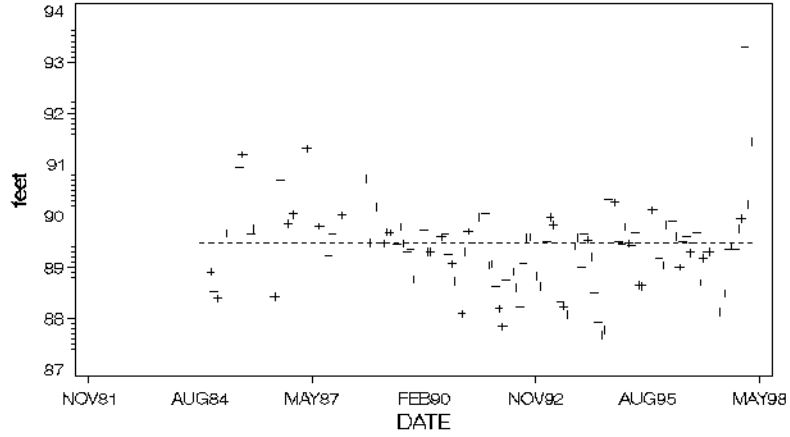

SPEC. CONDUCTANCE

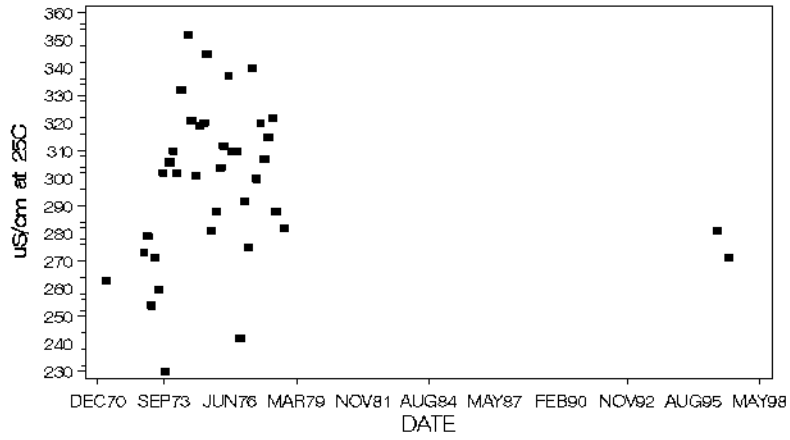

MAJOR IONS (% meq/l)

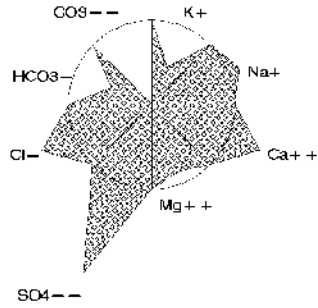

Lake Echo

Polk County

USGS Quadrangle: Winter Haven
 Section/Township/Range: 5-28S-26E
 Approx. Lake Center, Lat/Long: 280456/814403
 Surface Area: 69 acres
 Approx. Lake Elevation: 131 feet
 Average Depth: 11.8 feet
 Observed Maximum Depth: 16 feet
 (reference elevation 130.7 feet)
 Lake Type: outflow (type 2)
 Major Basin: Peace River
 Minor Basin: Lake Fannie Outlet
 Lake Region: Winter Haven/Lake Henry Ridges
 Public Access: yes

Major Land Use/Land Cover (1990)
 within 500 meters of the lakeshore:
 - medium density residential (55%)
 - tree crops, typically citrus (13%)
 - commercial and services (13%)

Total Number of Samples Collected: 1 Most Recent Sample Collected: August 1996

Parameter	Units (Detection Limit)	Average Value	District Percentile	Florida Percentile
Chlorophyll a	ug/l (1)	18.6	78	50
Total Phosphorus	mg/l as P (0.01)	0.010	33	5
Total Nitrogen	mg/l as N (0.06)	0.64	14	17
Transparency (Secchi depth)	meters	0.90	28	60
Florida Trophic State Index		51	75	37
Specific Conductance	S/cm at 25C (1)	208	63	53
pH	standard units (0.1)	8.2	85	75
Color	PtCo units (1)	10	34	10
Turbidity	NTU (1)	3.1	64	33
Total Alkalinity	mg/l as CaCO3 (1)	54	82	64
Hardness	mg/l as CaCO3 (0.02)	61	63	
Total Suspended Solids	mg/l (0.05)	3.6	69	
Ammonia	mg/l as N (0.03)	0.015	60	
Nitrate+Nitrite	mg/l as N (0.01)	0.005	33	
Total Kjeldahl Nitrogen	mg/l as N (0.06)	0.64	19	
Orthophosphorus	mg/l as P (0.01)	0.011	64	
Chloride	mg/l (0.05)	13	27	
Sulfate	mg/l (0.05)	20	61	
Sodium	mg/l (0.06)	22.0	94	
Potassium	mg/l (0.07)	0.5	11	
Calcium	mg/l (0.04)	18.0	69	
Magnesium	mg/l (0.006)	4.0	58	
Iron	ug/l (0.03)	34	46	

Based upon the average FTSI of 51, water quality is considered good. Lake Echo can be characterized as a clear (color<=10 color units), medium hard water, eutrophic lake, with low concentrations of total nitrogen. The chemical type of water (predominant ionic composition) is sodium bicarbonate.

Also of note:

- The measured pH was high.
- Cattails dominate more than 30% of the lake shoreline.

Plots and Trends: No or insufficient data for plotting or trend detection. Shown is a diagram of the relative ionic composition of the lake water.

MAJOR IONS (% meq/l)

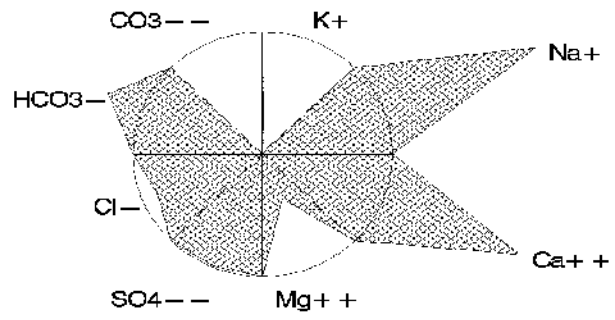

Lake Effie

Polk County

USGS Quadrangle: Lake Wales Major Land Use/Land Cover (1990)
 Section/Township/Range: 3-30S-27E within 500 meters of the lakeshore:
 Approx. Lake Center, Lat/Long: 275429/813619 - disturbed land (18%)
 Surface Area: 102 acres - industrial (15%)
 Approx. Lake Elevation: 117 feet - medium density residential (13%)
 Average Depth: 3.3 feet
 (reference elevation not given)
 Lake Type: inflow and outflow (type 3)
 Major Basin: Peace River
 Minor Basin: Lake Effie Outlet
 Lake Region: Southwestern Flatlands
 Public Access: yes

Total Number of Samples Collected: 2 Most Recent Sample Collected: January 1996

Parameter	Units (Detection Limit)	Average Value	District Percentile	Florida Percentile
Chlorophyll a	ug/l (1)	146.8	>95	>95
Total Phosphorus	mg/l as P (0.01)	0.096	93	65
Total Nitrogen	mg/l as N (0.06)	3.52	95	94
Transparency (Secchi depth)	meters	0.20	<5	<5
Florida Trophic State Index		92	>95	>95
Specific Conductance	S/cm at 25C (1)	352	93	73
pH	standard units (0.1)	9.2	>95	95
Color	PtCo units (1)	93	88	74
Turbidity	NTU (1)	24.5	>95	85
Total Alkalinity	mg/l as CaCO3 (1)	126	>95	>95
Hardness	mg/l as CaCO3 (0.02)	58	60	
Total Suspended Solids	mg/l (0.05)	11.7	93	
Ammonia	mg/l as N (0.03)	0.155	94	
Nitrate+Nitrite	mg/l as N (0.01)	0.108	82	
Total Kjeldahl Nitrogen	mg/l as N (0.06)	3.41	>95	
Orthophosphorus	mg/l as P (0.01)	0.062	95	
Chloride	mg/l (0.05)	20	56	
Sulfate	mg/l (0.05)	14	48	
Sodium	mg/l (0.06)	41.5	>95	
Potassium	mg/l (0.07)	26.5	>95	
Calcium	mg/l (0.04)	16.5	64	
Magnesium	mg/l (0.006)	4.1	59	
Iron	ug/l (0.03)	88	79	

Based upon the average FTSI of 92, water quality is considered poor. Lake Effie can be characterized as a highly colored, soft water, hypereutrophic lake. Of the 323 sample lakes, Lake Effie had the greatest Chlorophyll a concentrations, the greatest FTSI, and the lowest transparency. It was among the lakes having the greatest concentrations of total nitrogen. The chemical type of water (predominant ionic composition) is sodium bicarbonate. It was the only sodium bicarbonate lake of the 323 lakes sampled. The measured pH was very high.

Plots and Trends: The record of lake elevation shows a rapid drop in lake level after 1973. Lake levels remained low until very recently (1998), however, the record is incomplete. Lake Effie received effluent from a nearby orange juice processing plant. The plant now sprays the effluent onto adjacent fields. The available data for hardness, total alkalinity, and conductance were highly variable over the period of record, probably due to the effects of the effluent. Also shown is a diagram of the relative ionic composition of the lake water.

MONTHLY AVERAGE SURFACE ELEVATION

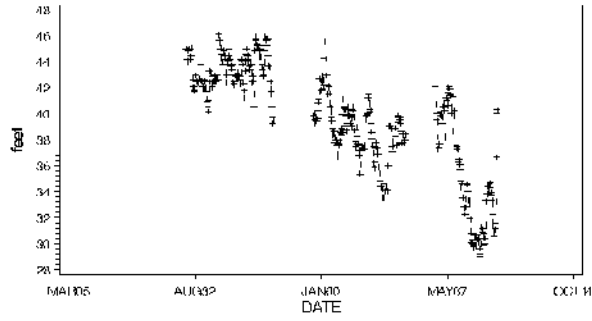

SPEC. CONDUCTANCE

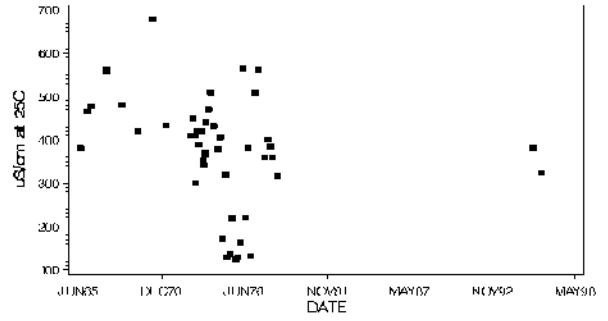

TOTAL ALKALINITY

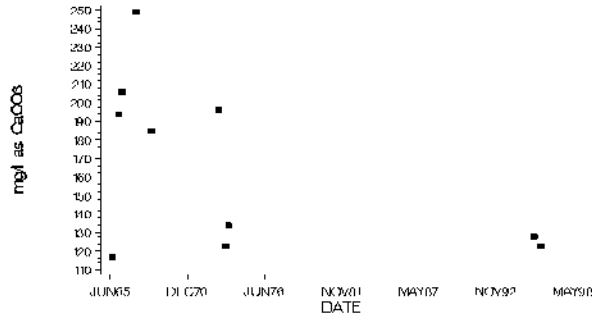

HARDNESS

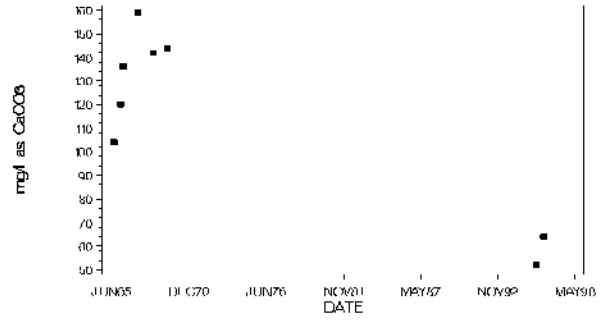

MAJOR IONS (% meq/l)

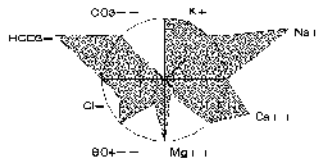

Lake Elbert Polk County

USGS Quadrangle:	Winter Haven	Major Land Use/Land Cover (1990)
Section/Township/Range:	22-28S-26E	within 500 meters of the lakeshore:
Approx. Lake Center, Lat/Long:	280133/814233	- medium density residential (64%)
Surface Area:	173 acres	- institutional (20%)
Approx. Lake Elevation:	136 feet	- open land (7%)

Average Depth: 15.1 feet
(reference elevation 133 feet)
Lake Type: outflow (type 2)
Major Basin: Peace River
Minor Basin: Lake Elbert
Lake Region: Winter Haven/Lake Henry Ridges
Public Access: yes

Total Number of Samples Collected: 2 Most Recent Sample Collected: January 1997

Parameter	Units (Detection Limit)	Average Value	District Percentile	Florida Percentile
Chlorophyll a	ug/l (1)	3.7	33	15
Total Phosphorus	mg/l as P (0.01)	0.009	31	<5
Total Nitrogen	mg/l as N (0.06)	0.72	19	21
Transparency (Secchi depth)	meters	4.00	93	>95
Florida Trophic State Index		26	18	<5
Specific Conductance	S/cm at 25C (1)	173	46	47
pH	standard units (0.1)	7.8	74	63
Color	PtCo units (1)	8	24	8
Turbidity	NTU (1)	0.5	28	<5
Total Alkalinity	mg/l as CaCO3 (1)	36	67	53
Hardness	mg/l as CaCO3 (0.02)	59	61	
Total Suspended Solids	mg/l (0.05)	0.4	8	
Ammonia	mg/l as N (0.03)	0.015	60	
Nitrate+Nitrite	mg/l as N (0.01)	0.034	61	
Total Kjeldahl Nitrogen	mg/l as N (0.06)	0.69	23	
Orthophosphorus	mg/l as P (0.01)	0.005	56	
Chloride	mg/l (0.05)	13	27	
Sulfate	mg/l (0.05)	25	71	
Sodium	mg/l (0.06)	7.5	39	
Potassium	mg/l (0.07)	3.9	54	
Calcium	mg/l (0.04)	18.0	69	
Magnesium	mg/l (0.006)	3.4	50	
Iron	ug/l (0.03)	25	30	

Based upon the average FTSI of 26, water quality is considered good. Lake Elbert can be characterized as a clear (color<=10 color units), soft water, oligo-mesotrophic lake, with low concentrations of total phosphorus, low concentrations of total nitrogen. The chemical type of water (predominant ionic composition) is calcium sulfate.

Also of note:

- Hydrilla was observed in the lake.
- Cattails dominate more than 30% of the lake shoreline.

Plots and Trends: The plot of lake surface elevation shows that lake levels in Lake Elbert have risen sharply since the early 1990s. Also shown is a diagram of the relative ionic composition of the lake water.

MONTHLY AVERAGE SURFACE ELEVATION

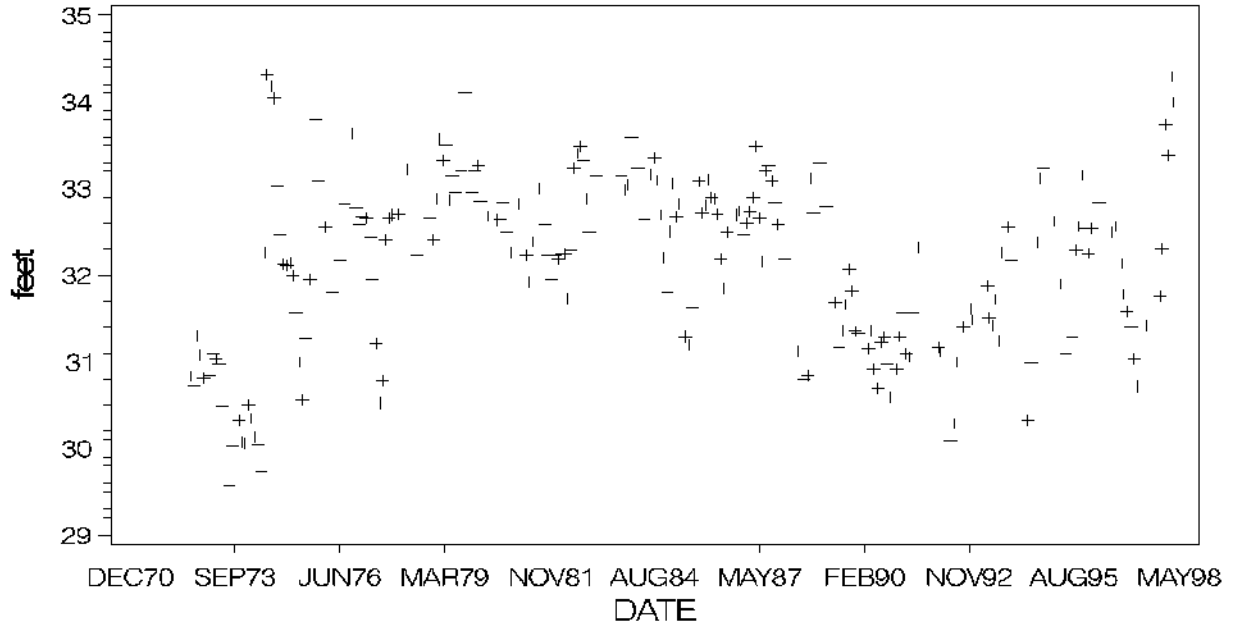

MAJOR IONS (% meq/l)

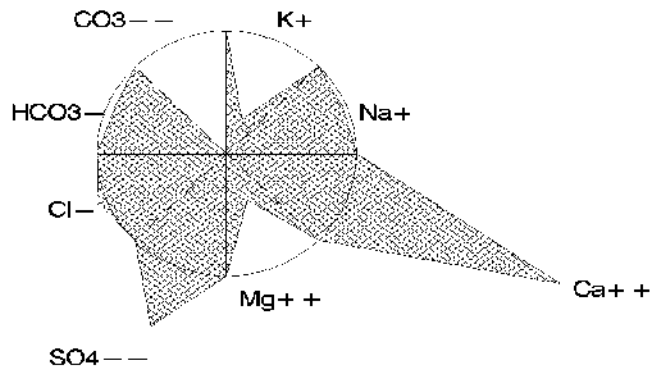

Lake Eloise

Polk County

USGS Quadrangle: Eloise Major Land Use/Land Cover (1990)
 Section/Township/Range: 3-29S-26E within 500 meters of the lakeshore:
 Approx. Lake Center, Lat/Long: 275859/814213 - medium density residential (30%)
 Surface Area: 1160 acres - tree crops, typically citrus (21%)
 Approx. Lake Elevation: 132 feet - commercial and services (13%)
 Average Depth: 10.8 feet
 Observed Maximum Depth: 16 feet
 (reference elevation 130 feet)
 Lake Type: 3
 Major Basin: Peace River
 Minor Basin: Lake Lulu Outlet
 Lake Region: Winter Haven/Lake Henry Ridges
 Public Access: yes

Total Number of Samples Collected: 2 Most Recent Sample Collected: January 1997

Parameter	Units (Detection Limit)	Average Value	District Percentile	Florida Percentile
Chlorophyll a	ug/l (1)	31.3	86	66
Total Phosphorus	mg/l as P (0.01)	0.023	69	13
Total Nitrogen	mg/l as N (0.06)	1.53	70	62
Transparency (Secchi depth)	meters	0.76	22	46
Florida Trophic State Index		56	79	46
Specific Conductance	S/cm at 25C (1)	261	81	62
pH	standard units (0.1)	8.2	85	75
Color	PtCo units (1)	8	24	8
Turbidity	NTU (1)	5.5	75	53
Total Alkalinity	mg/l as CaCO3 (1)	57	85	66
Hardness	mg/l as CaCO3 (0.02)	82	82	
Total Suspended Solids	mg/l (0.05)	5.6	80	
Ammonia	mg/l as N (0.03)	0.029	60	
Nitrate+Nitrite	mg/l as N (0.01)	0.020	51	
Total Kjeldahl Nitrogen	mg/l as N (0.06)	1.51	78	
Orthophosphorus	mg/l as P (0.01)	0.017	83	
Chloride	mg/l (0.05)	26	78	
Sulfate	mg/l (0.05)	29	75	
Sodium	mg/l (0.06)	15.0	83	
Potassium	mg/l (0.07)	6.3	76	
Calcium	mg/l (0.04)	22.5	82	
Magnesium	mg/l (0.006)	6.2	77	
Iron	ug/l (0.03)	86	78	

Based upon the average FTSI of 56, water quality is considered good. Lake Eloise can be characterized as a clear (color<=10 color units), medium hard water, eutrophic lake. The chemical type of water (predominant ionic composition) is calcium chloride. The measured pH was high.

Plots and Trends: The water chemistry of Lake Eloise has been highly variable over the period of record. Total nitrogen and total phosphorus were very high during the 1970s. During that period total alkalinity and pH were quite high, indicating that productivity was fairly great during that period also, although no co-temporal data for Chlorophyll a were available. The more recent total phosphorus concentrations, though relatively high, are an order of magnitude lower than for the samples collected through the 1980s. Lake Lulu is upstream from Lake Eloise and received treatment plant effluent during the 1970s. The effluent was probably the source of excessive nutrients in Lake Eloise during that period. Also shown is a diagram of the relative ionic composition of the lake water.

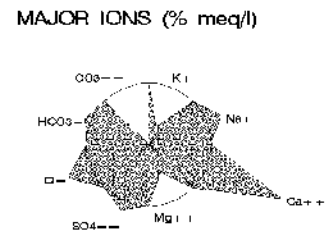
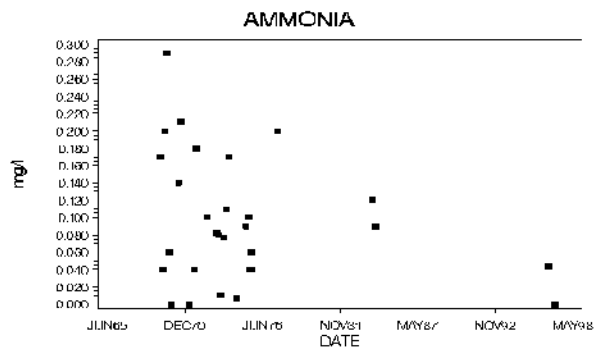
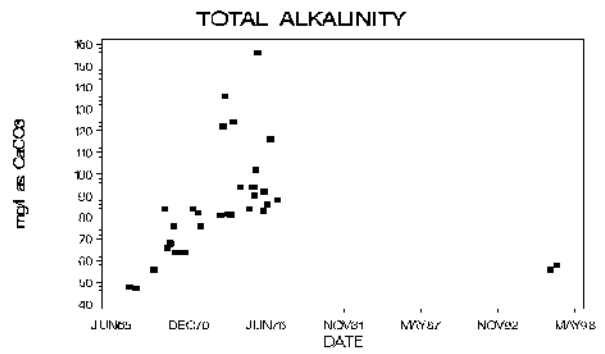
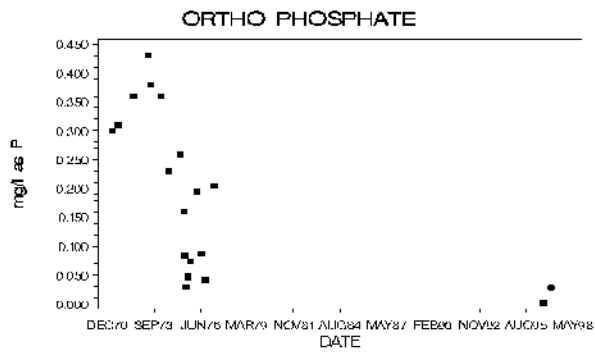
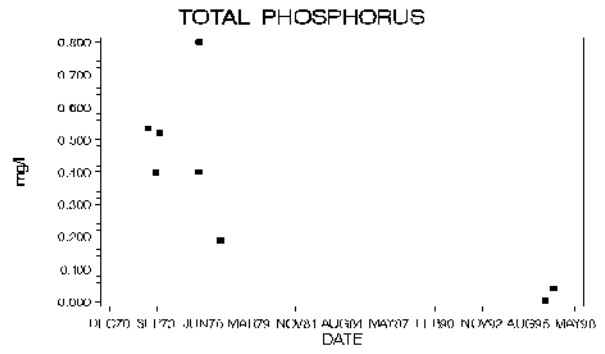
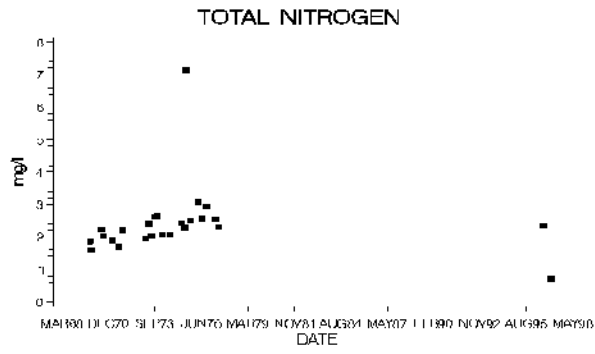
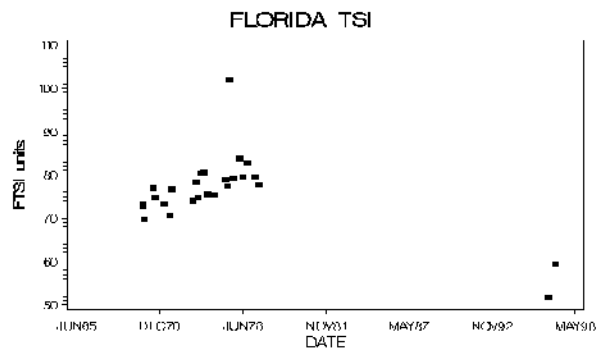
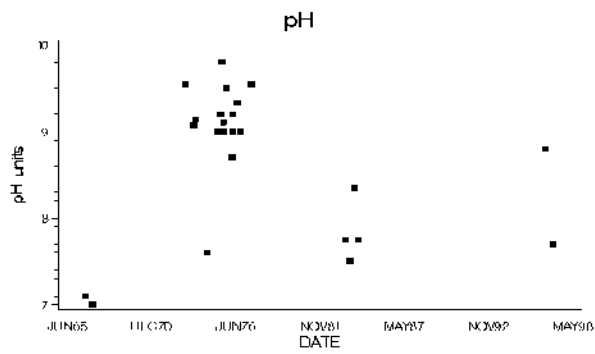

Lake Eloise, Polk County

Lake Fannie

Polk County

USGS Quadrangle: Winter Haven Major Land Use/Land Cover (1990)
 Section/Township/Range: 11-28S-26E within 500 meters of the lakeshore:
 Approx. Lake Center, Lat/Long: 280334/814124 - tree crops, typically citrus (16%)
 Surface Area: 829 acres - freshwater marshes (14%)
 Approx. Lake Elevation: 126 feet - cropland and pastureland (14%)
 Average Depth: 5.9 feet
 (reference elevation 124 feet)
 Lake Type: inflow and outflow (type 3)
 Major Basin: Peace River
 Minor Basin: Lake Fannie Outlet
 Lake Region: Winter Haven/Lake Henry Ridges
 Public Access: yes

Total Number of Samples Collected: 2 Most Recent Sample Collected: February 1997

Parameter	Units (Detection Limit)	Average Value	District Percentile	Florida Percentile
Chlorophyll a	ug/l (1)	25.3	83	59
Total Phosphorus	mg/l as P (0.01)	0.012	41	6
Total Nitrogen	mg/l as N (0.06)	1.21	56	41
Transparency (Secchi depth)	meters	0.79	23	49
Florida Trophic State Index		54	78	42
Specific Conductance	S/cm at 25C (1)	261	81	62
pH	standard units (0.1)	7.7	69	60
Color	PtCo units (1)	30	67	23
Turbidity	NTU (1)	6.8	81	59
Total Alkalinity	mg/l as CaCO3 (1)	67	90	71
Hardness	mg/l as CaCO3 (0.02)	77	77	
Total Suspended Solids	mg/l (0.05)	7.0	87	
Ammonia	mg/l as N (0.03)	0.015	60	
Nitrate+Nitrite	mg/l as N (0.01)	0.005	33	
Total Kjeldahl Nitrogen	mg/l as N (0.06)	1.21	63	
Orthophosphorus	mg/l as P (0.01)	0.010	59	
Chloride	mg/l (0.05)	27	80	
Sulfate	mg/l (0.05)	16	52	
Sodium	mg/l (0.06)	18.5	90	
Potassium	mg/l (0.07)	7.0	81	
Calcium	mg/l (0.04)	18.0	69	
Magnesium	mg/l (0.006)	7.9	83	
Iron	ug/l (0.03)	33	44	

Based upon the average FTSI of 54, water quality is considered good. Lake Fannie can be characterized as a moderately colored, medium hard water, eutrophic to hypereutrophic lake. The chemical type of water (predominant ionic composition) is calcium chloride (1 sample) or sodium chloride (1 sample).

Also of note:

- Cattails dominate more than 30% of the lake shoreline.

Plots and Trends: Lake surface elevations have remained relatively high through the 1990s, although within the typical range of fluctuation for Lake Fannie. Specific conductance data show no consistent trend. Also shown is a diagram of the relative ionic composition of the lake water.

MONTHLY AVERAGE SURFACE ELEVATION

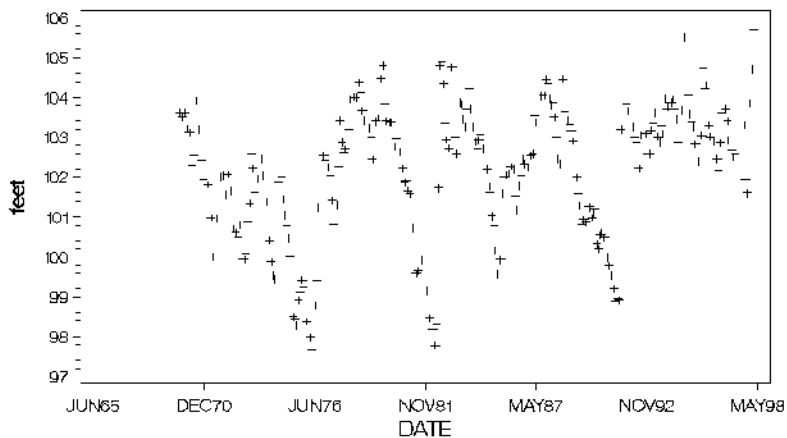

SPEC. CONDUCTANCE

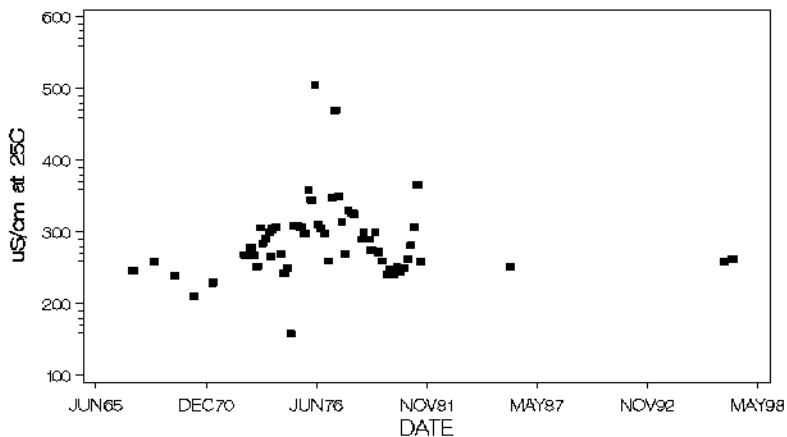

MAJOR IONS (% meq/l)

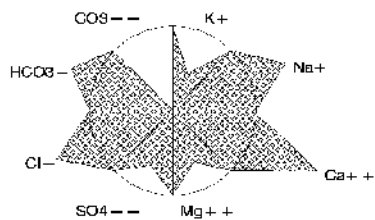

Lake Fannie, Polk County

Gadau Lake

Polk County

USGS Quadrangle: Alturas Major Land Use/Land Cover (1990)
 Section/Township/Range: 23-30S-26E within 500 meters of the lakeshore:
 Approx. Lake Center, Lat/Long: 275138/814142 - tree crops, typically citrus (47%)
 Surface Area: 143 acres - cropland and pastureland (36%)
 Approx. Lake Elevation: 121 feet - wetland forested mixed (5%)
 Lake Type: inflow and outflow (type 3)
 Major Basin: Peace River
 Minor Basin: Lake Pembroke Outlet
 Lake Region: Winter Haven/Lake Henry Ridges

Total Number of Samples Collected: 2 Most Recent Sample Collected: January 1996

Parameter	Units (Detection Limit)	Average Value	District Percentile	Florida Percentile
Chlorophyll a	ug/l (1)	24.8	83	58
Total Phosphorus	mg/l as P (0.01)	0.028	75	18
Total Nitrogen	mg/l as N (0.06)	2.60	92	89
Transparency (Secchi depth)	meters	0.45	<5	13
Florida Trophic State Index		63	86	60
Specific Conductance	S/cm at 25C (1)	227	69	56
pH	standard units (0.1)	8.4	90	80
Color	PtCo units (1)	28	65	22
Turbidity	NTU (1)	11.2	90	72
Total Alkalinity	mg/l as CaCO3 (1)	19	41	38
Hardness	mg/l as CaCO3 (0.02)	77	77	
Total Suspended Solids	mg/l (0.05)	5.9	81	
Ammonia	mg/l as N (0.03)	0.067	82	
Nitrate+Nitrite	mg/l as N (0.01)	0.550	92	
Total Kjeldahl Nitrogen	mg/l as N (0.06)	2.05	91	
Orthophosphorus	mg/l as P (0.01)	0.019	84	
Chloride	mg/l (0.05)	23	69	
Sulfate	mg/l (0.05)	35	85	
Sodium	mg/l (0.06)	7.0	33	
Potassium	mg/l (0.07)	12.0	93	
Calcium	mg/l (0.04)	13.0	53	
Magnesium	mg/l (0.006)	10.7	89	
Iron	ug/l (0.03)	27	33	

Based upon the average FTSI of 63, water quality is considered fair. Gadau Lake can be characterized as a moderately colored, medium hard water, eutrophic lake, with high concentrations of total nitrogen. The chemical type of water (predominant ionic composition) is calcium sulfate.

Also of note:

- The measured pH was high.

Plots and Trends: No or insufficient data available for plotting or trend detection. Shown is a diagram of the relative ionic composition of the lake water.

MAJOR IONS (% meq/l)

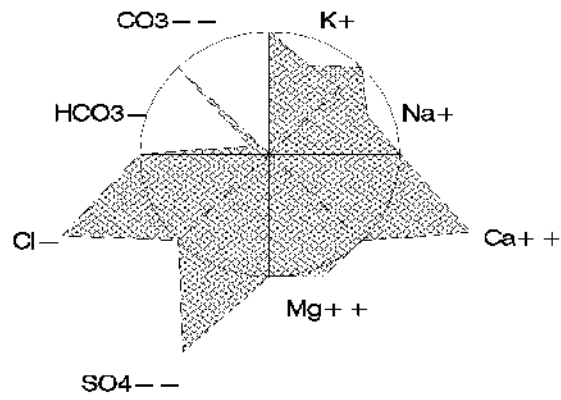

Lake Galloway (Hidden) Polk County

USGS Quadrangle: Plant City East Major Land Use/Land Cover (1990)
 Section/Township/Range: 27-27S-23E within 500 meters of the lakeshore:
 Approx. Lake Center, Lat/Long: 280648/820011 - stream and lake swamps (40%)
 Surface Area: 34 acres - cropland and pastureland (26%)
 Approx. Lake Elevation: 128 feet - tree crops, typically citrus (15%)
 Lake Type: outflow (type 2)
 Major Basin: Hillsborough River
 Minor Basin: Kathleen Drain
 Lake Region: Lakeland/Bone Valley Upland

Total Number of Samples Collected: 2 Most Recent Sample Collected: January 1996

Parameter	Units (Detection Limit)	Average Value	District Percentile	Florida Percentile
Chlorophyll a	ug/l (1)	67.2	>95	90
Total Phosphorus	mg/l as P (0.01)	0.222	>95	85
Total Nitrogen	mg/l as N (0.06)	1.77	78	74
Transparency (Secchi depth)	meters	0.47	6	16
Florida Trophic State Index		74	>95	89
Specific Conductance	S/cm at 25C (1)	133	26	36
pH	standard units (0.1)	7.9	78	67
Color	PtCo units (1)	250	>95	>95
Turbidity	NTU (1)	6.0	77	55
Total Alkalinity	mg/l as CaCO3 (1)	36	67	53
Hardness	mg/l as CaCO3 (0.02)	49	51	
Total Suspended Solids	mg/l (0.05)	3.9	72	
Ammonia	mg/l as N (0.03)	0.099	87	
Nitrate+Nitrite	mg/l as N (0.01)	0.005	33	
Total Kjeldahl Nitrogen	mg/l as N (0.06)	1.77	84	
Orthophosphorus	mg/l as P (0.01)	0.191	>95	
Chloride	mg/l (0.05)	15	34	
Sulfate	mg/l (0.05)	4	17	
Sodium	mg/l (0.06)	9.3	55	
Potassium	mg/l (0.07)	2.1	35	
Calcium	mg/l (0.04)	12.0	48	
Magnesium	mg/l (0.006)	4.6	65	
Iron	ug/l (0.03)	100	82	

Based upon the average FTSI of 74, water quality is considered poor. Lake Galloway (Hidden) can be characterized as a highly colored, soft water, hypereutrophic lake, with high concentrations of total phosphorus. Lake Galloway had the third highest concentration of total phosphorus of the 323 sample lakes. The chemical type of water (predominant ionic composition) is calcium bicarbonate (1 sample) or calcium chloride (1 sample).

Plots and Trends: No or insufficient data available for plotting or trend detection. Shown is a diagram of the relative ionic composition of the lake water.

MAJOR IONS (% meq/l)

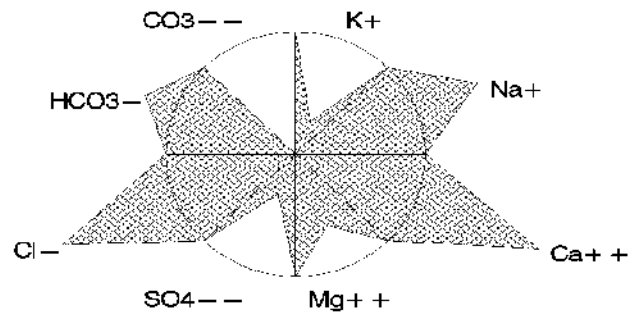

Lake Galloway (Hidden), Polk County

Lake Garfield

Polk County

USGS Quadrangle: Eloise Major Land Use/Land Cover (1990)
 Section/Township/Range: 5-30S-26E within 500 meters of the lakeshore:
 Approx. Lake Center, Lat/Long: 275415/814358 - freshwater marshes (30%)
 Surface Area: 655 acres - tree crops, typically citrus (20%)
 Approx. Lake Elevation: 105 feet - other open lands - rural (17%)
 Lake Type: inflow and outflow (type 3)
 Major Basin: Peace River
 Minor Basin: Boggy Branch
 Lake Region: Southwestern Flatlands
 Public Access: yes

Total Number of Samples Collected: 2 Most Recent Sample Collected: December 1996

Parameter	Units (Detection Limit)	Average Value	District Percentile	Florida Percentile
Chlorophyll a	ug/l (1)	37.2	89	72
Total Phosphorus	mg/l as P (0.01)	0.098	94	66
Total Nitrogen	mg/l as N (0.06)	1.41	67	51
Transparency (Secchi depth)	meters	0.31	<5	<5
Florida Trophic State Index		77	>95	92
Specific Conductance	S/cm at 25C (1)	111	16	28
pH	standard units (0.1)	6.9	29	28
Color	PtCo units (1)	188	>95	>95
Turbidity	NTU (1)	18.4	>95	80
Total Alkalinity	mg/l as CaCO3 (1)	8	21	22
Hardness	mg/l as CaCO3 (0.02)	29	19	
Total Suspended Solids	mg/l (0.05)	15.4	>95	
Ammonia	mg/l as N (0.03)	0.055	79	
Nitrate+Nitrite	mg/l as N (0.01)	0.014	42	
Total Kjeldahl Nitrogen	mg/l as N (0.06)	1.40	75	
Orthophosphorus	mg/l as P (0.01)	0.034	91	
Chloride	mg/l (0.05)	18	46	
Sulfate	mg/l (0.05)	12	41	
Sodium	mg/l (0.06)	6.3	25	
Potassium	mg/l (0.07)	6.0	73	
Calcium	mg/l (0.04)	4.0	9	
Magnesium	mg/l (0.006)	4.5	63	
Iron	ug/l (0.03)	356	>95	

Based upon the average FTSI of 77, water quality is considered poor. Lake Garfield can be characterized as a highly colored, soft water, eutrophic lake, with high concentrations of total phosphorus. The chemical type of water (predominant ionic composition) is sodium chloride.

Plots and Trends: There are no trends evident in the plots of lake surface elevation or specific conductance. Also shown is a diagram of the relative ionic composition of the lake water.

MONTHLY AVERAGE SURFACE ELEVATION

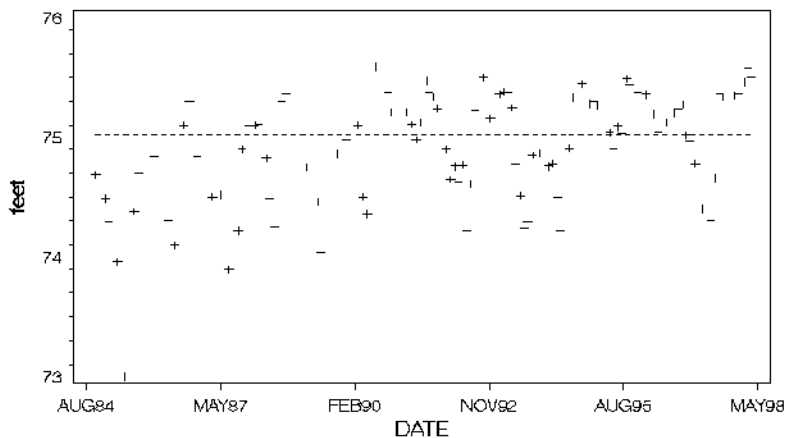

SPEC. CONDUCTANCE

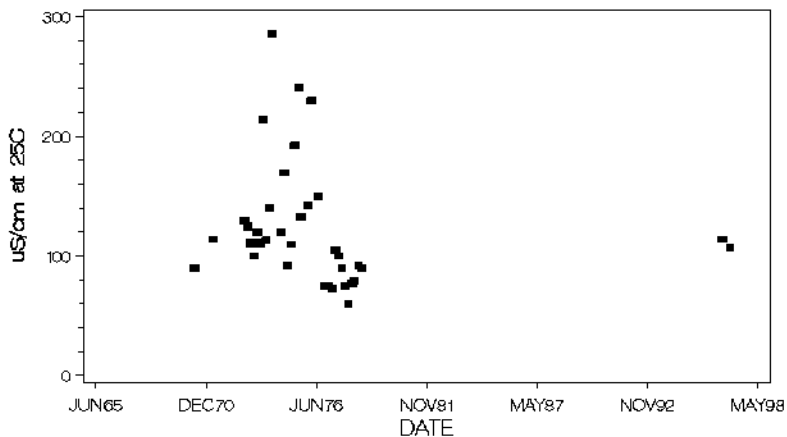

MAJOR IONS (% meq/l)

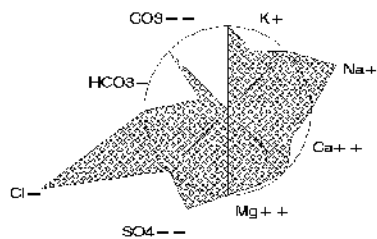

Lake Garfield, Polk County

Lake Gibson

Polk County

USGS Quadrangle:	Lakeland	Major Land Use/Land Cover (1990)
Section/Township/Range:	25-27S-23E	within 500 meters of the lakeshore:
Approx. Lake Center, Lat/Long:	280631/815740	- medium density residential (34%)
Surface Area:	474 acres	- high density residential (16%)
Approx. Lake Elevation:	144 feet	- institutional (8%)
Average Depth: 6 feet		
Observed Maximum Depth: 20 feet		
(reference elevation 141.5 feet)		
Lake Type: outflow (type 2)		
Major Basin: Peace River		
Minor Basin: Saddle Creek		
Lake Region: Southwestern Flatlands		
Public Access: yes		

Total Number of Samples Collected: 2 Most Recent Sample Collected: January 1997

Parameter	Units (Detection Limit)	Average Value	District Percentile	Florida Percentile
Chlorophyll a	ug/l (1)	74.5	>95	91
Total Phosphorus	mg/l as P (0.01)	0.080	92	60
Total Nitrogen	mg/l as N (0.06)	1.02	42	34
Transparency (Secchi depth)	meters	1.18	39	69
Florida Trophic State Index		56	80	47
Specific Conductance	S/cm at 25C (1)	136	29	38
pH	standard units (0.1)	8.6	92	85
Color	PtCo units (1)	45	76	35
Turbidity	NTU (1)	8.3	84	64
Total Alkalinity	mg/l as CaCO3 (1)	17	39	35
Hardness	mg/l as CaCO3 (0.02)	34	27	
Total Suspended Solids	mg/l (0.05)	3.6	69	
Ammonia	mg/l as N (0.03)	0.015	60	
Nitrate+Nitrite	mg/l as N (0.01)	0.005	33	
Total Kjeldahl Nitrogen	mg/l as N (0.06)	1.02	49	
Orthophosphorus	mg/l as P (0.01)	0.054	94	
Chloride	mg/l (0.05)	14	30	
Sulfate	mg/l (0.05)	14	48	
Sodium	mg/l (0.06)	9.3	55	
Potassium	mg/l (0.07)	2.8	45	
Calcium	mg/l (0.04)	8.3	29	
Magnesium	mg/l (0.006)	3.2	48	
Iron	ug/l (0.03)	81	75	

Based upon the average FTSI of 56, water quality is considered good. Lake Gibson can be characterized as a colored, soft water, meso-eutrophic lake, with high concentrations of total phosphorus, The chemical type of water (predominant ionic composition) is calcium chloride (2 samples) or sodium chloride (1 sample).

Also of note:

- The measured pH was high.

Plots and Trends: Lake surface elevations demonstrate no trend for the period of record, however, since 1985 the lake has fluctuated through a narrower range of elevations than during the previous decades. The present range in fluctuation is typically within 1 to 2 feet per year. Measures of water chemistry show no change over the period of record. Also shown is a diagram of the relative ionic composition of the lake water.

MONTHLY AVERAGE SURFACE ELEVATION

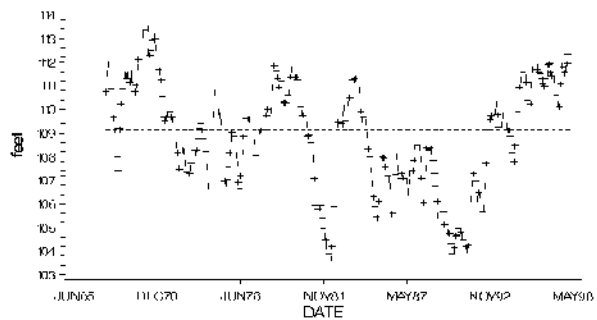

SPEC. CONDUCTANCE

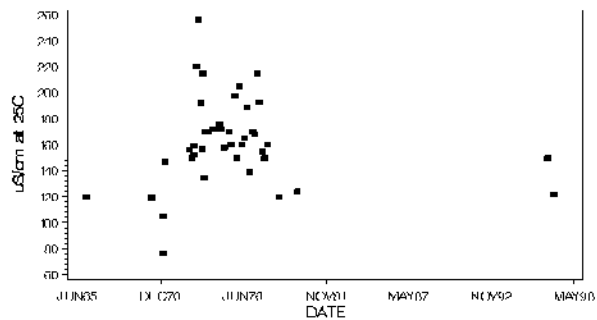

TOTAL ALKALINITY

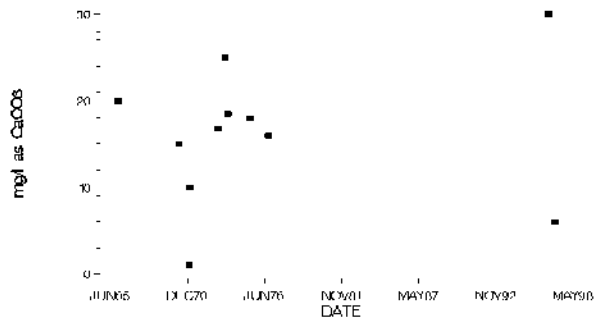

MAJOR IONS (% meq/l)

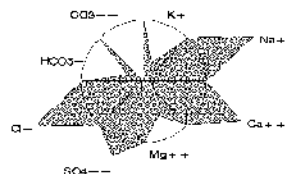

Lake Gordon (SW) Polk County

USGS Quadrangle: Alturas Major Land Use/Land Cover (1990)
 Section/Township/Range: 21-30S-27E within 500 meters of the lakeshore:
 Approx. Lake Center, Lat/Long: 275051/813752 - tree crops, typically citrus (29%)
 Surface Area: 77 acres - stream and lake swamps (15%)
 Approx. Lake Elevation: 114 feet - cropland and pastureland (14%)
 Lake Type: outflow (type 2)
 Major Basin: Peace River
 Minor Basin: Peace Cr Trib Canal
 Lake Region: Lake Wales Ridge Transition

Total Number of Samples Collected: 2 Most Recent Sample Collected: January 1996

Parameter	Units (Detection Limit)	Average Value	District Percentile	Florida Percentile
Chlorophyll a	ug/l (1)	4.4	40	18
Total Phosphorus	mg/l as P (0.01)	0.023	69	13
Total Nitrogen	mg/l as N (0.06)	1.60	72	65
Transparency (Secchi depth)	meters	0.75	21	45
Florida Trophic State Index		42	56	18
Specific Conductance	S/cm at 25C (1)	135	28	37
pH	standard units (0.1)	6.7	21	23
Color	PtCo units (1)	150	94	91
Turbidity	NTU (1)	4.4	72	45
Total Alkalinity	mg/l as CaCO3 (1)	8	21	22
Hardness	mg/l as CaCO3 (0.02)	40	36	
Total Suspended Solids	mg/l (0.05)	1.6	42	
Ammonia	mg/l as N (0.03)	0.065	81	
Nitrate+Nitrite	mg/l as N (0.01)	0.874	94	
Total Kjeldahl Nitrogen	mg/l as N (0.06)	0.73	27	
Orthophosphorus	mg/l as P (0.01)	0.014	76	
Chloride	mg/l (0.05)	18	46	
Sulfate	mg/l (0.05)	19	58	
Sodium	mg/l (0.06)	7.5	39	
Potassium	mg/l (0.07)	4.6	62	
Calcium	mg/l (0.04)	5.8	18	
Magnesium	mg/l (0.006)	6.2	77	
Iron	ug/l (0.03)	213	93	

Based upon the average FTSI of 42, water quality is considered good. Lake Gordon (SW) can be characterized as a highly colored, soft water, oligo-mesotrophic lake. The chemical type of water (predominant ionic composition) is sodium chloride.

Also of note:

- Cattails dominate more than 30% of the lake shoreline.
- Waterhyacinth was observed in the lake.

Plots and Trends: No or insufficient data available for plotting or trend detection. Shown is a diagram of the relative ionic composition of the lake water.

MAJOR IONS (% meq/l)

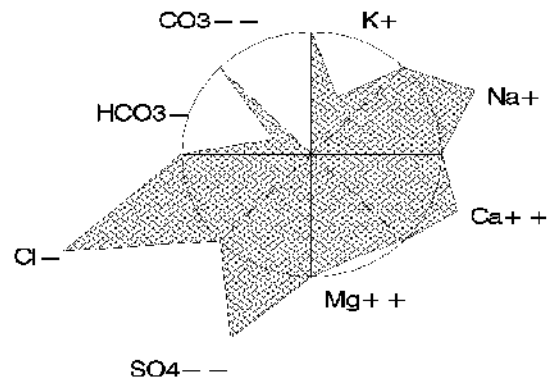

Lake Gordon (SW), Polk County

Lake Gordon

Polk County

USGS Quadrangle: Alturas Major Land Use/Land Cover (1990)
 Section/Township/Range: 21-30S-27E within 500 meters of the lakeshore:
 Approx. Lake Center, Lat/Long: 275120/813739 - cropland and pastureland (49%)
 Surface Area: 147 acres - freshwater marshes (16%)
 Approx. Lake Elevation: 114 feet - stream and lake swamps (13%)
 Lake Type: inflow and outflow (type 3)
 Major Basin: Peace River
 Minor Basin: Peace Cr Trib Canal
 Lake Region: Lake Wales Ridge Transition

Total Number of Samples Collected: 2 Most Recent Sample Collected: January 1996

Parameter	Units (Detection Limit)	Average Value	District Percentile	Florida Percentile
Chlorophyll a	ug/l (1)	4.0	36	16
Total Phosphorus	mg/l as P (0.01)	0.026	73	16
Total Nitrogen	mg/l as N (0.06)	1.10	48	37
Transparency (Secchi depth)	meters	0.50	9	20
Florida Trophic State Index		47	68	29
Specific Conductance	S/cm at 25C (1)	105	14	25
pH	standard units (0.1)	6.4	12	15
Color	PtCo units (1)	213	>95	>95
Turbidity	NTU (1)	1.4	39	11
Total Alkalinity	mg/l as CaCO3 (1)	7	18	20
Hardness	mg/l as CaCO3 (0.02)	26	16	
Total Suspended Solids	mg/l (0.05)	0.4	8	
Ammonia	mg/l as N (0.03)	0.024	60	
Nitrate+Nitrite	mg/l as N (0.01)	0.070	77	
Total Kjeldahl Nitrogen	mg/l as N (0.06)	1.03	50	
Orthophosphorus	mg/l as P (0.01)	0.013	72	
Chloride	mg/l (0.05)	17	41	
Sulfate	mg/l (0.05)	10	37	
Sodium	mg/l (0.06)	7.3	36	
Potassium	mg/l (0.07)	3.9	54	
Calcium	mg/l (0.04)	4.4	10	
Magnesium	mg/l (0.006)	2.6	38	
Iron	ug/l (0.03)	375	>95	

Based upon the average FTSI of 47, water quality is considered good. Lake Gordon can be characterized as a highly colored, soft water, meso-eutrophic lake. The chemical type of water (predominant ionic composition) is sodium chloride.

Also of note:

- Waterhyacinth was observed in the lake.

Plots and Trends: No or insufficient data available for plotting or trend detection. Shown is a diagram of the relative ionic composition of the lake water.

MAJOR IONS (% meq/l)

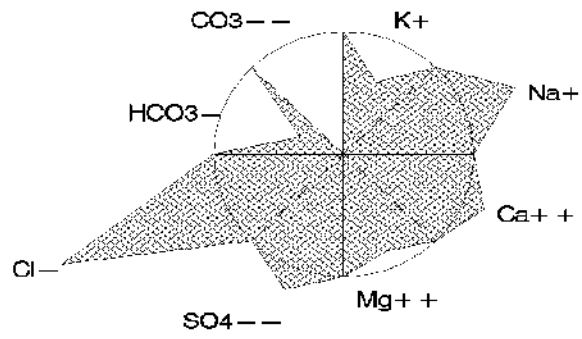

Lake Gordon, Polk County

Lake Haines

Polk County

USGS Quadrangle: Winter Haven Major Land Use/Land Cover (1990)
 Section/Township/Range: 33-27S-26E within 500 meters of the lakeshore:
 Approx. Lake Center, Lat/Long: 280531/814224 - stream and lake swamps (21%)
 Surface Area: 716 acres - tree crops, typically citrus (17%)
 Approx. Lake Elevation: 129 feet - medium density residential (11%)
 Average Depth: 10.8 feet
 (reference elevation not given)
 Lake Type: outflow (type 2)
 Major Basin: Peace River
 Minor Basin: Lake Fannie Outlet
 Lake Region: Southwestern Flatlands
 Public Access: yes

Total Number of Samples Collected: 2 Most Recent Sample Collected: February 1997

Parameter	Units (Detection Limit)	Average Value	District Percentile	Florida Percentile
Chlorophyll a	ug/l (1)	98.1	>95	>95
Total Phosphorus	mg/l as P (0.01)	0.079	92	59
Total Nitrogen	mg/l as N (0.06)	1.81	79	76
Transparency (Secchi depth)	meters	0.52	11	22
Florida Trophic State Index		71	95	84
Specific Conductance	S/cm at 25C (1)	205	61	53
pH	standard units (0.1)	9.1	>95	94
Color	PtCo units (1)	55	80	45
Turbidity	NTU (1)	27.0	>95	87
Total Alkalinity	mg/l as CaCO3 (1)	63	89	69
Hardness	mg/l as CaCO3 (0.02)	63	65	
Total Suspended Solids	mg/l (0.05)	15.7	>95	
Ammonia	mg/l as N (0.03)	0.015	60	
Nitrate+Nitrite	mg/l as N (0.01)	0.005	33	
Total Kjeldahl Nitrogen	mg/l as N (0.06)	1.81	85	
Orthophosphorus	mg/l as P (0.01)	0.013	72	
Chloride	mg/l (0.05)	22	64	
Sulfate	mg/l (0.05)	5	20	
Sodium	mg/l (0.06)	13.0	76	
Potassium	mg/l (0.07)	7.5	84	
Calcium	mg/l (0.04)	16.5	64	
Magnesium	mg/l (0.006)	5.3	72	
Iron	ug/l (0.03)	102	82	

Based upon the average FTSI of 71, water quality is considered poor. Lake Haines can be characterized as a colored, medium hard water, eutrophic lake, with high concentrations of total phosphorus and high concentrations of total nitrogen. The chemical type of water (predominant ionic composition) is calcium chloride (2 samples) or calcium bicarbonate.

Also of note:

- The measured pH was very high.
- Cattails dominate more than 30% of the lake shoreline.

Plots and Trends: All of the plots of water chemistry for Lake Haines show a wide range of variability, though no trends are evident. Also shown is a diagram of the relative ionic composition of the lake water.

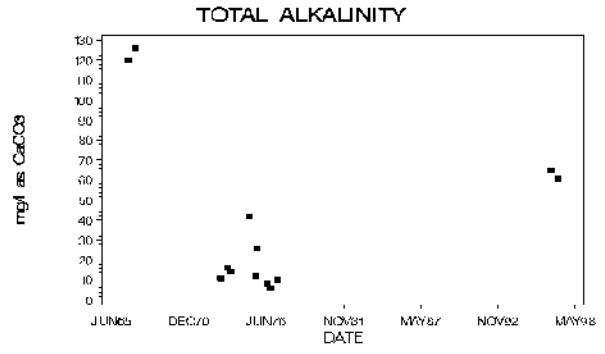
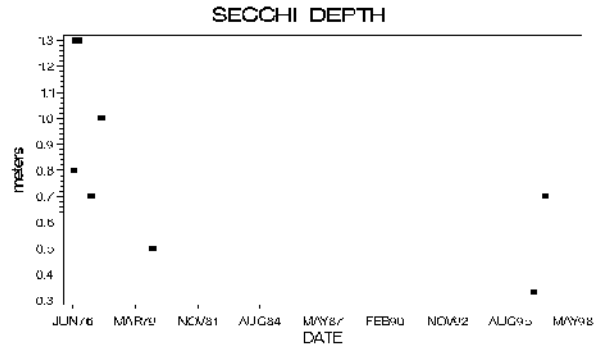
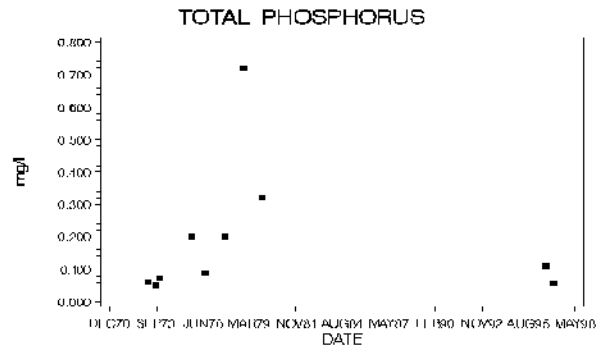
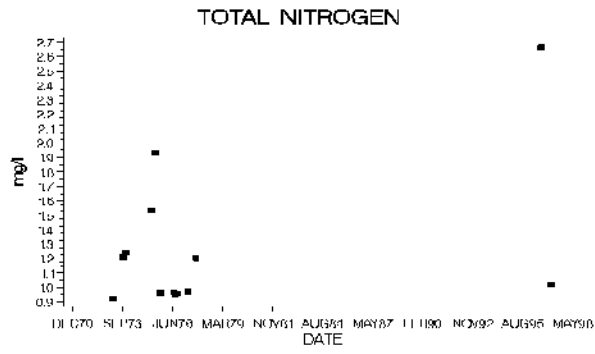
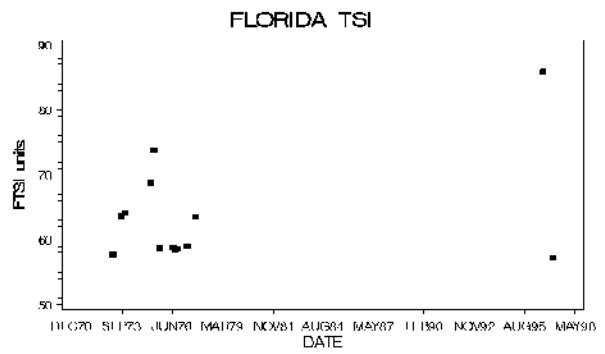
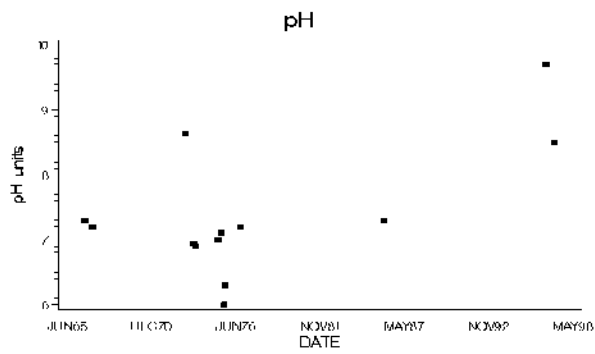

MAJOR IONS (% meq/l)

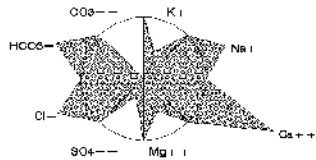

Lake Hamilton

Polk County

USGS Quadrangle: Winter Haven Major Land Use/Land Cover (1990)
 Section/Township/Range: 18-28S-27E within 500 meters of the lakeshore:
 Approx. Lake Center, Lat/Long: 280256/813910 - tree crops, typically citrus (21%)
 Surface Area: 2162 acres - cropland and pastureland (14%)
 Approx. Lake Elevation: 122 feet - stream and lake swamps (13%)
 Average Depth: 7.1 feet
 Observed Maximum Depth: 12 feet
 (reference elevation 120 feet)
 Lake Type: inflow and outflow (type 3)
 Major Basin: Peace River
 Minor Basin: Lake Hamilton Outlet
 Lake Region: Southwestern Flatlands
 Public Access: yes

Total Number of Samples Collected: 2 Most Recent Sample Collected: February 1997

Parameter	Units (Detection Limit)	Average Value	District Percentile	Florida Percentile
Chlorophyll a	ug/l (1)	6.2	50	27
Total Phosphorus	mg/l as P (0.01)	0.089	93	63
Total Nitrogen	mg/l as N (0.06)	0.75	23	23
Transparency (Secchi depth)	meters	0.74	20	44
Florida Trophic State Index		52	77	39
Specific Conductance	S/cm at 25C (1)	208	63	53
pH	standard units (0.1)	7.7	69	60
Color	PtCo units (1)	70	84	60
Turbidity	NTU (1)	8.1	84	64
Total Alkalinity	mg/l as CaCO3 (1)	26	52	45
Hardness	mg/l as CaCO3 (0.02)	46	48	
Total Suspended Solids	mg/l (0.05)	2.6	60	
Ammonia	mg/l as N (0.03)	0.015	60	
Nitrate+Nitrite	mg/l as N (0.01)	0.018	48	
Total Kjeldahl Nitrogen	mg/l as N (0.06)	0.74	28	
Orthophosphorus	mg/l as P (0.01)	0.062	95	
Chloride	mg/l (0.05)	28	82	
Sulfate	mg/l (0.05)	22	65	
Sodium	mg/l (0.06)	22.0	94	
Potassium	mg/l (0.07)	4.7	64	
Calcium	mg/l (0.04)	7.4	26	
Magnesium	mg/l (0.006)	6.8	80	
Iron	ug/l (0.03)	123	86	

Based upon the average FTSI of 52, water quality is considered good. Lake Hamilton can be characterized as a colored, soft water, mesotrophic lake, with high concentrations of total phosphorus. The chemical type of water (predominant ionic composition) is sodium chloride.

Plots and Trends: Lake Hamilton has a long period of record for surface elevation, extending back in time over 50 years. Elevations from 1943 up to about 1953 appear to have been greater than at any other time during the period of record. Except for that one decade, lake levels have generally been stable over the long-term. There is no trend in specific conductivity, and the data for hardness are too sparse to draw conclusions about any change over time. Also shown is a diagram of the relative ionic composition of the lake water.

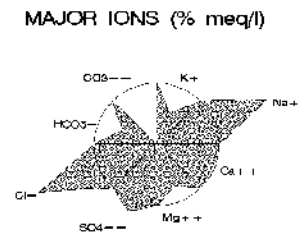
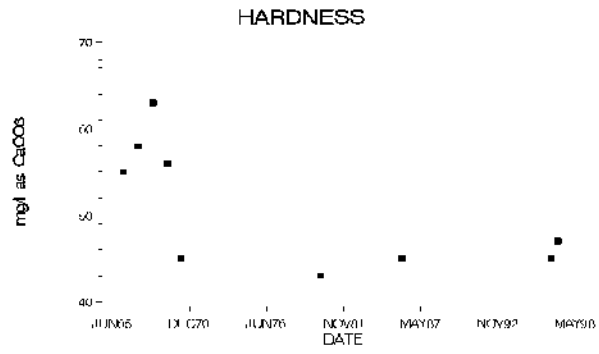
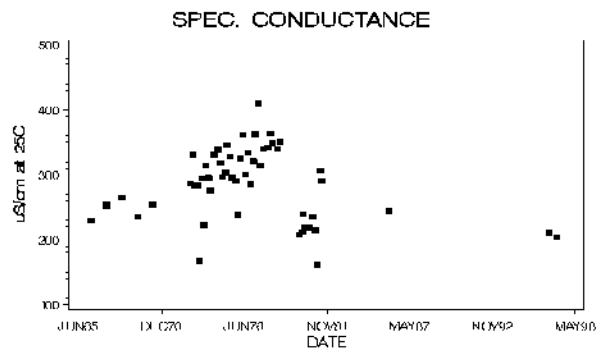
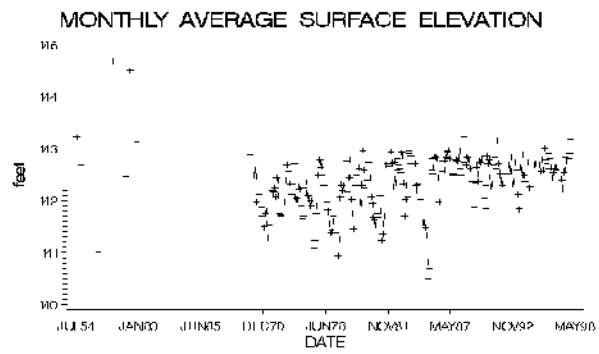

Lake Hamilton, Polk County

Lake Hancock

Polk County

USGS Quadrangle: Bartow Major Land Use/Land Cover (1990)
 Section/Township/Range: 8-29S-25E within 500 meters of the lakeshore:
 Approx. Lake Center, Lat/Long: 275819/815019 - stream and lake swamps (38%)
 Surface Area: 4519 acres - cropland and pastureland (22%)
 Approx. Lake Elevation: 99 feet - extractive (14%)
 Average Depth: 2.8 feet
 Observed Maximum Depth: 5 feet
 (reference elevation 97 feet)
 Lake Type: inflow and outflow (type 3)
 Major Basin: Peace River
 Minor Basin: Saddle Creek
 Lake Region: Southwestern Flatlands
 Public Access: yes

Total Number of Samples Collected: 2 Most Recent Sample Collected: January 1997

Parameter	Units (Detection Limit)	Average Value	District Percentile	Florida Percentile
Chlorophyll a	ug/l (1)	80.5	>95	92
Total Phosphorus	mg/l as P (0.01)	0.138	>95	77
Total Nitrogen	mg/l as N (0.06)	2.49	91	87
Transparency (Secchi depth)	meters	0.27	<5	<5
Florida Trophic State Index		72	95	85
Specific Conductance	S/cm at 25C (1)	234	74	57
pH	standard units (0.1)	10.0	>95	>95
Color	PtCo units (1)	60	82	50
Turbidity	NTU (1)	23.5	>95	84
Total Alkalinity	mg/l as CaCO3 (1)	62	87	69
Hardness	mg/l as CaCO3 (0.02)	71	73	
Total Suspended Solids	mg/l (0.05)	47.2	>95	
Ammonia	mg/l as N (0.03)	0.030	61	
Nitrate+Nitrite	mg/l as N (0.01)	0.013	41	
Total Kjeldahl Nitrogen	mg/l as N (0.06)	2.48	>95	
Orthophosphorus	mg/l as P (0.01)	0.072	>95	
Chloride	mg/l (0.05)	17	41	
Sulfate	mg/l (0.05)	11	39	
Sodium	mg/l (0.06)	11.5	66	
Potassium	mg/l (0.07)	3.1	47	
Calcium	mg/l (0.04)	20.5	77	
Magnesium	mg/l (0.006)	4.8	66	
Iron	ug/l (0.03)	96	80	

Based upon the average FTSI of 72, water quality is considered poor. Lake Hancock can be characterized as a colored, medium hard water, hypereutrophic lake, with high concentrations of total phosphorus and high concentrations of total nitrogen. The chemical type of water (predominant ionic composition) is calcium bicarbonate (1 sample) or calcium chloride (1 sample).

Also of note:

- The measured pH was very high.

Plots and Trends: No trend is evident in the plot of lake surface elevation, however, the range in annual fluctuation seems to have narrowed over the period of record, from around 3 feet to less than 2 feet. Lake Hancock is among lakes with the greatest concentrations of total phosphorus and total nitrogen. The pH appeared lower between 1965 and 1970. All variables plotted demonstrate a large range in variability, but no trends are clearly evident. Also shown is a diagram of the relative ionic composition of the lake water.

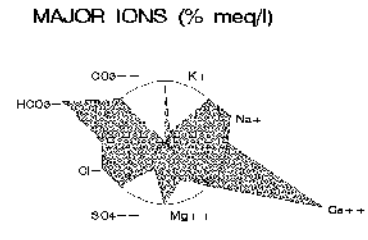
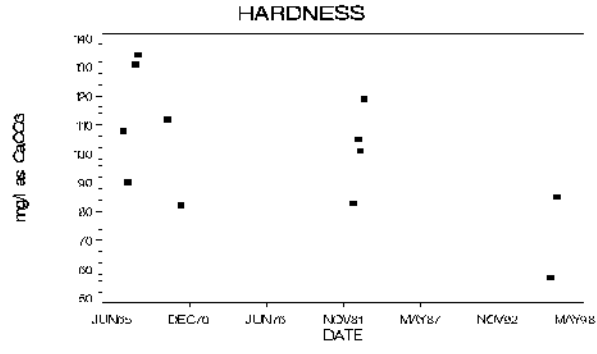
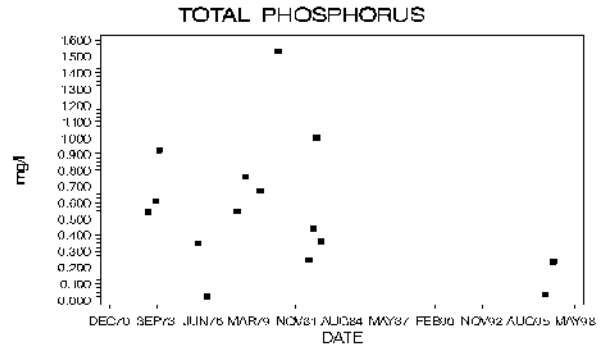
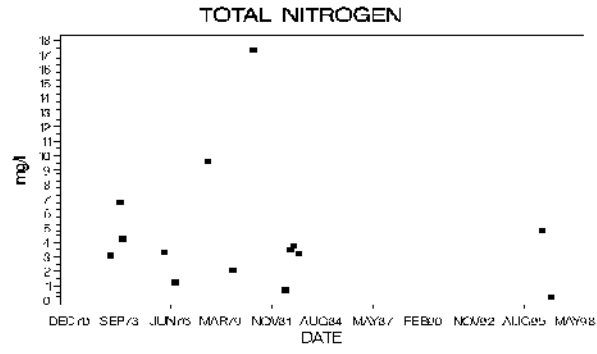
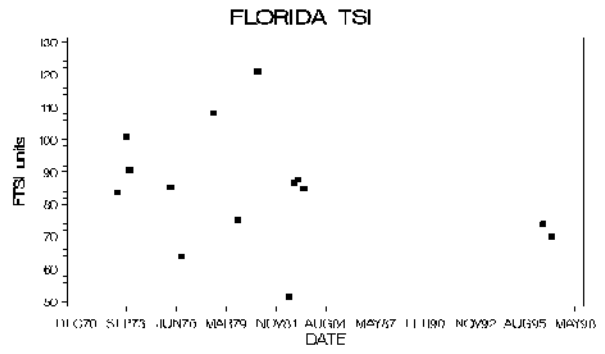
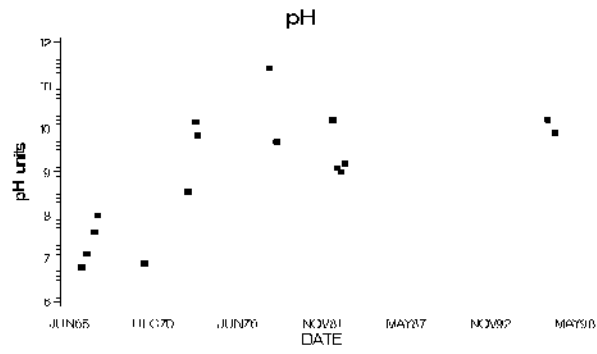
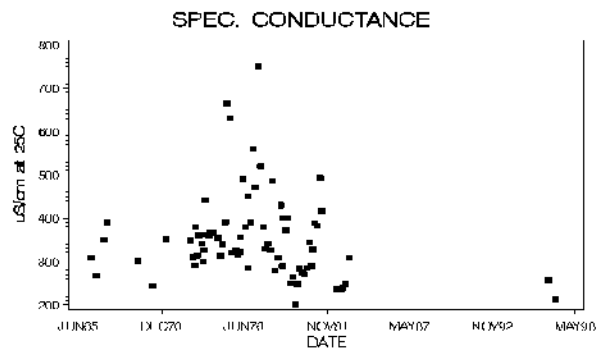
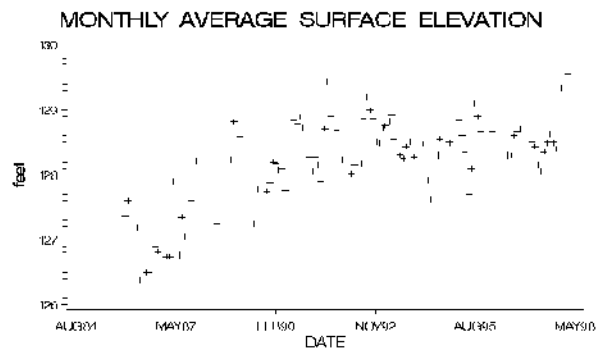

Lake Hancock, Polk County

Lake Hartridge

Polk County

USGS Quadrangle: Winter Haven Major Land Use/Land Cover (1990)
 Section/Township/Range: 8-28S-26E within 500 meters of the lakeshore:
 Approx. Lake Center, Lat/Long: 280320/814433 - medium density residential (32%)
 Surface Area: 434 acres - commercial and services (17%)
 Approx. Lake Elevation: 132 feet - transportation (10%)
 Average Depth: 9.3 feet
 Observed Maximum Depth: 14 feet
 (reference elevation 130 feet)
 Lake Type: inflow and outflow (type 3)
 Major Basin: Peace River
 Minor Basin: Lake Lulu Outlet
 Lake Region: Winter Haven/Lake Henry Ridges
 Public Access: yes

Total Number of Samples Collected: 2 Most Recent Sample Collected: February 1997

Parameter	Units (Detection Limit)	Average Value	District Percentile	Florida Percentile
Chlorophyll a	ug/l (1)	8.9	60	35
Total Phosphorus	mg/l as P (0.01)	0.014	50	7
Total Nitrogen	mg/l as N (0.06)	0.83	27	27
Transparency (Secchi depth)	meters	1.62	53	78
Florida Trophic State Index		41	56	17
Specific Conductance	S/cm at 25C (1)	220	67	55
pH	standard units (0.1)	7.9	78	67
Color	PtCo units (1)	10	34	10
Turbidity	NTU (1)	2.0	51	20
Total Alkalinity	mg/l as CaCO3 (1)	57	85	66
Hardness	mg/l as CaCO3 (0.02)	70	72	
Total Suspended Solids	mg/l (0.05)	1.9	49	
Ammonia	mg/l as N (0.03)	0.015	60	
Nitrate+Nitrite	mg/l as N (0.01)	0.005	33	
Total Kjeldahl Nitrogen	mg/l as N (0.06)	0.83	34	
Orthophosphorus	mg/l as P (0.01)	0.008	56	
Chloride	mg/l (0.05)	20	56	
Sulfate	mg/l (0.05)	21	63	
Sodium	mg/l (0.06)	13.0	76	
Potassium	mg/l (0.07)	6.3	76	
Calcium	mg/l (0.04)	18.5	71	
Magnesium	mg/l (0.006)	5.7	75	
Iron	ug/l (0.03)	22	26	

Based upon the average FTSI of 41, water quality is considered good. Lake Hartridge can be characterized as a clear (color<=10 color units), medium hard water, meso-eutrophic lake. The chemical type of water (predominant ionic composition) is calcium bicarbonate (1 sample) or calcium chloride (1 sample).

Also of note:

- Cattails dominate more than 30% of the lake shoreline.

Plots and Trends: Plots of water chemistry variables in Lake Hartridge reveal no trends over the period of record. Also shown is a diagram of the relative ionic composition of the lake water.

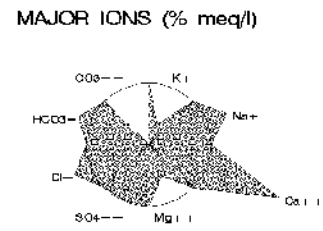
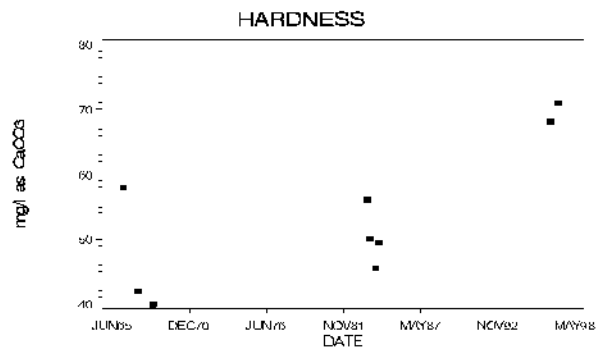
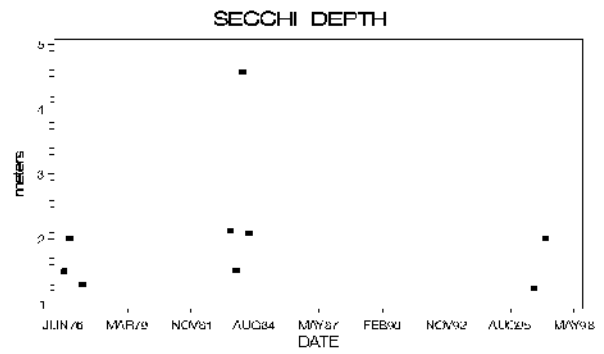
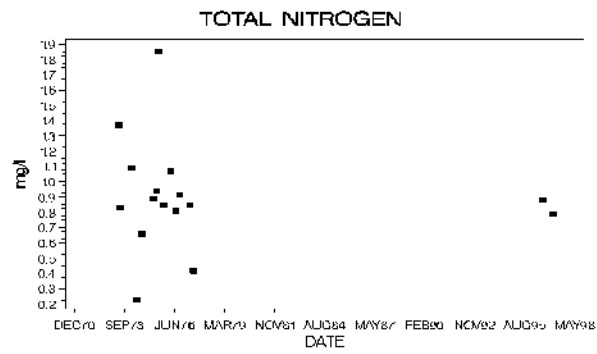
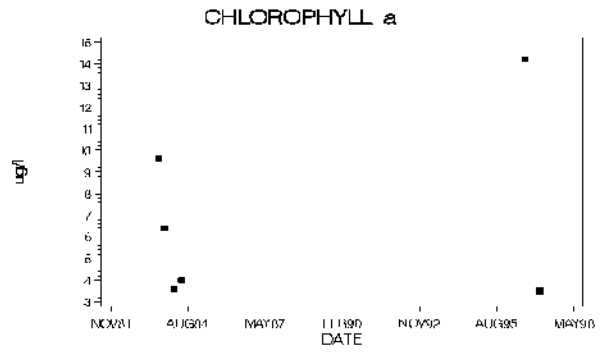
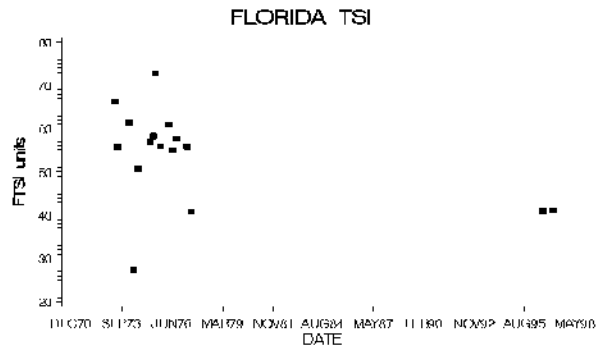
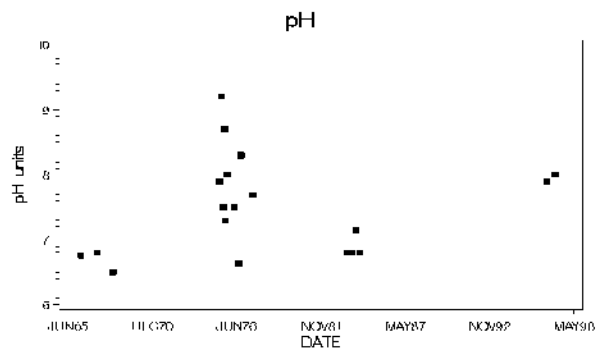
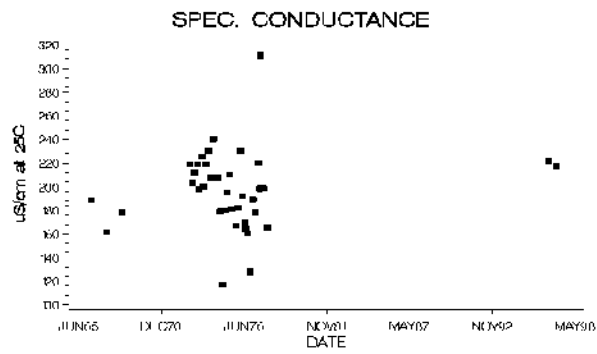

Lake Hartridge, Polk County

Lake Henry

Polk County

USGS Quadrangle: Winter Haven Major Land Use/Land Cover (1990)
 Section/Township/Range: 36-27S-26E within 500 meters of the lakeshore:
 Approx. Lake Center, Lat/Long: 280526/814000 - stream and lake swamps (27%)
 Surface Area: 857 acres - high density residential (24%)
 Approx. Lake Elevation: 127 feet - tree crops, typically citrus (16%)
 Average Depth: 6.9 feet
 (reference elevation 125 feet)
 Lake Type: outflow (type 2)
 Major Basin: Peace River
 Minor Basin: Lake Hamilton Outlet
 Lake Region: Southwestern Flatlands

Total Number of Samples Collected: 2 Most Recent Sample Collected: January 1996

Parameter	Units (Detection Limit)	Average Value	District Percentile	Florida Percentile
Chlorophyll a	ug/l (1)	2.3	15	10
Total Phosphorus	mg/l as P (0.01)	0.137	>95	77
Total Nitrogen	mg/l as N (0.06)	1.58	71	64
Transparency (Secchi depth)	meters	0.40	<5	5
Florida Trophic State Index		45	62	24
Specific Conductance	S/cm at 25C (1)	138	30	38
pH	standard units (0.1)	6.6	18	20
Color	PtCo units (1)	275	>95	>95
Turbidity	NTU (1)	9.5	87	68
Total Alkalinity	mg/l as CaCO3 (1)	8	21	22
Hardness	mg/l as CaCO3 (0.02)	30	21	
Total Suspended Solids	mg/l (0.05)	3.5	67	
Ammonia	mg/l as N (0.03)	0.168	95	
Nitrate+Nitrite	mg/l as N (0.01)	0.136	84	
Total Kjeldahl Nitrogen	mg/l as N (0.06)	1.44	76	
Orthophosphorus	mg/l as P (0.01)	0.132	>95	
Chloride	mg/l (0.05)	21	61	
Sulfate	mg/l (0.05)	13	45	
Sodium	mg/l (0.06)	12.5	73	
Potassium	mg/l (0.07)	5.8	72	
Calcium	mg/l (0.04)	5.6	17	
Magnesium	mg/l (0.006)	3.9	57	
Iron	ug/l (0.03)	261	94	

Based upon the average FTSI of 45, water quality is considered good. Lake Henry can be characterized as a highly colored, soft water, mesotrophic lake, with high concentrations of total phosphorus. The chemical type of water (predominant ionic composition) is sodium chloride.

Plots and Trends: Lake Henry surface elevations have generally increased during the 1990s, recovering from the depressed elevations of the 1970s and 1980s. Recent measures of specific conductivity are within the ranges typical for the period of record. Also shown is a diagram of the relative ionic composition of the lake water.

MONTHLY AVERAGE SURFACE ELEVATION

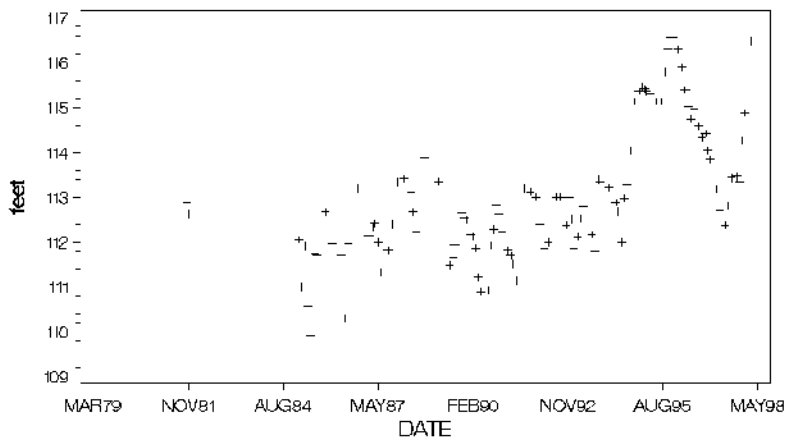

SPEC. CONDUCTANCE

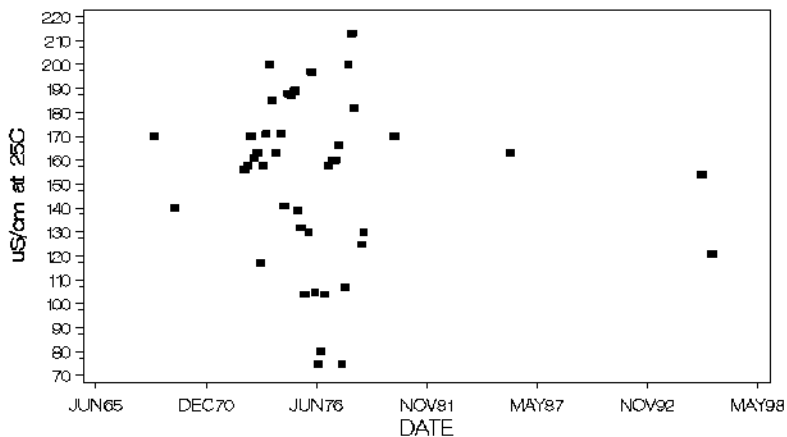

MAJOR IONS (% meq/l)

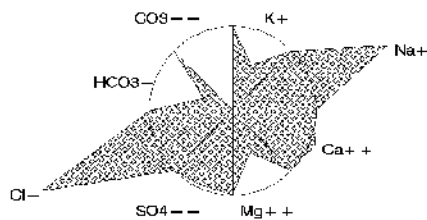

Lake Henry, Polk County

Lake Hickory

Polk County

USGS Quadrangle: Frostproof Major Land Use/Land Cover (1990)
 Section/Township/Range: 17-32S-28E within 500 meters of the lakeshore:
 Approx. Lake Center, Lat/Long: 274202/813224 - tree crops, typically citrus (65%)
 Surface Area: 100 acres - cropland and pastureland (10%)
 Approx. Lake Elevation: 99 feet - medium density residential (6%)
 Lake Type: outflow (type 2)
 Major Basin: Kissimmee Ridge
 Minor Basin: Livingston Creek
 Lake Region: Northern Lake Wales Ridge

Total Number of Samples Collected: 2 Most Recent Sample Collected: January 1995

Parameter	Units (Detection Limit)	Average Value	District Percentile	Florida Percentile
Chlorophyll a	ug/l (1)	45.7	93	79
Total Phosphorus	mg/l as P (0.01)	0.024	71	14
Total Nitrogen	mg/l as N (0.06)	3.06	95	92
Transparency (Secchi depth)	meters	0.45	<5	13
Florida Trophic State Index		68	93	75
Specific Conductance	S/cm at 25C (1)	442	>95	79
pH	standard units (0.1)	7.7	69	60
Color	PtCo units (1)	48	77	38
Turbidity	NTU (1)	19.8	>95	82
Total Alkalinity	mg/l as CaCO3 (1)	74	94	74
Hardness	mg/l as CaCO3 (0.02)	178	>95	
Total Suspended Solids	mg/l (0.05)	12.9	94	
Ammonia	mg/l as N (0.03)	0.472	>95	
Nitrate+Nitrite	mg/l as N (0.01)	0.546	92	
Total Kjeldahl Nitrogen	mg/l as N (0.06)	2.51	>95	
Orthophosphorus	mg/l as P (0.01)	0.023	87	
Chloride	mg/l (0.05)	34	90	
Sulfate	mg/l (0.05)	87	>95	
Sodium	mg/l (0.06)	8.7	50	
Potassium	mg/l (0.07)	16.0	>95	
Calcium	mg/l (0.04)	32.5	94	
Magnesium	mg/l (0.006)	23.5	>95	
Iron	ug/l (0.03)	16	11	

Based upon the average FTSI of 68, water quality is considered fair. Lake Hickory can be characterized as a colored, hard water, eutrophic to hypereutrophic lake, with high concentrations of total nitrogen. The chemical type of water (predominant ionic composition) is calcium sulfate.

Plots and Trends: The plot of lake surface elevation shows that lake elevations in Lake Hickory have been generally stable over the short period of record. Also shown is a diagram of the relative ionic composition of the lake water.

MONTHLY AVERAGE SURFACE ELEVATION

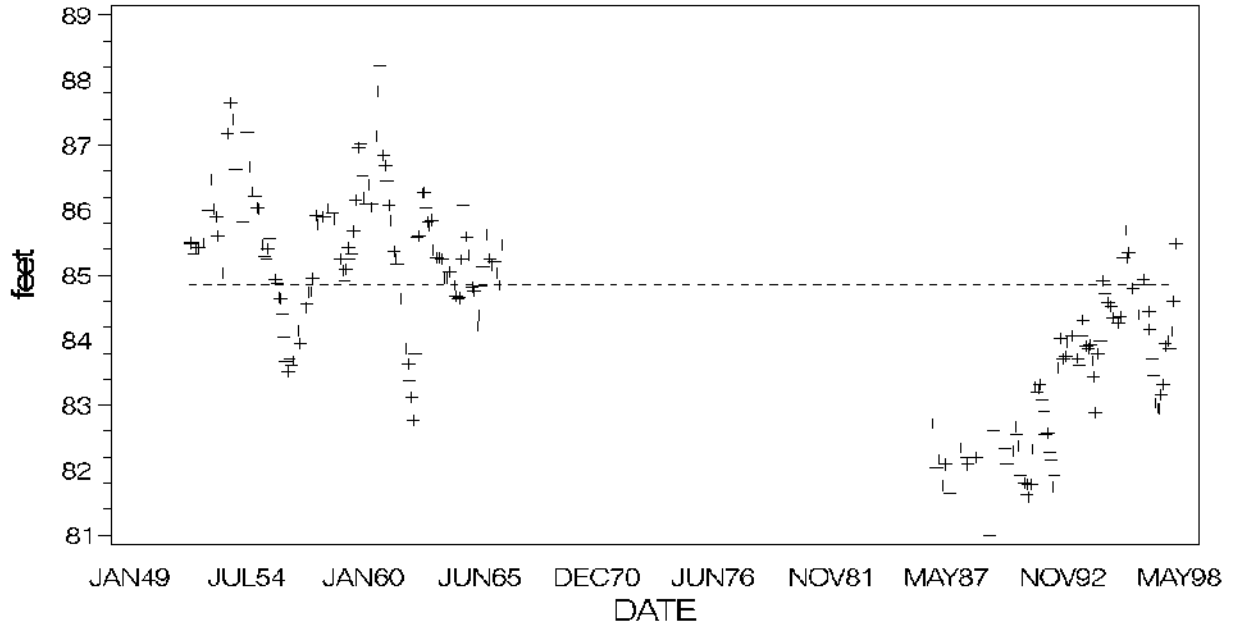

MAJOR IONS (% meq/l)

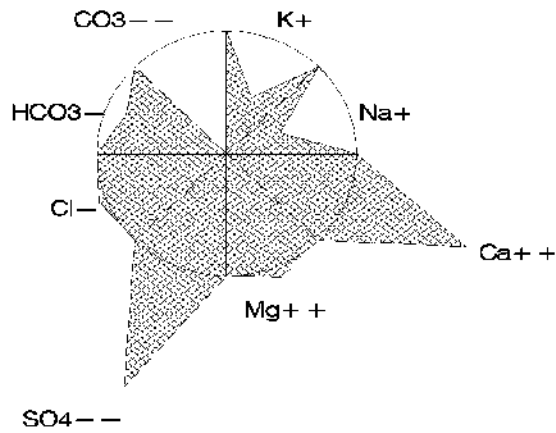

Lake Howard

Polk County

USGS Quadrangle: Winter Haven Major Land Use/Land Cover (1990)
 Section/Township/Range: 30-28S-26E within 500 meters of the lakeshore:
 Approx. Lake Center, Lat/Long: 280127/814442 - medium density residential (57%)
 Surface Area: 628 acres - commercial and services (19%)
 Approx. Lake Elevation: 132 feet - open land (8%)
 Average Depth: 8.8 feet
 Observed Maximum Depth: 14 feet
 (reference elevation 130 feet)
 Lake Type: inflow and outflow (type 3)
 Major Basin: Peace River
 Minor Basin: Lake Lulu Outlet
 Lake Region: Winter Haven/Lake Henry Ridges
 Public Access: yes

Total Number of Samples Collected: 2 Most Recent Sample Collected: February 1997

Parameter	Units (Detection Limit)	Average Value	District Percentile	Florida Percentile
Chlorophyll a	ug/l (1)	38.6	90	73
Total Phosphorus	mg/l as P (0.01)	0.022	68	12
Total Nitrogen	mg/l as N (0.06)	1.83	80	77
Transparency (Secchi depth)	meters	0.50	9	20
Florida Trophic State Index		65	90	66
Specific Conductance	S/cm at 25C (1)	185	53	49
pH	standard units (0.1)	8.9	>95	91
Color	PtCo units (1)	13	41	12
Turbidity	NTU (1)	8.6	85	65
Total Alkalinity	mg/l as CaCO3 (1)	68	91	72
Hardness	mg/l as CaCO3 (0.02)	72	74	
Total Suspended Solids	mg/l (0.05)	8.8	89	
Ammonia	mg/l as N (0.03)	0.015	60	
Nitrate+Nitrite	mg/l as N (0.01)	0.005	33	
Total Kjeldahl Nitrogen	mg/l as N (0.06)	1.83	87	
Orthophosphorus	mg/l as P (0.01)	0.011	64	
Chloride	mg/l (0.05)	17	41	
Sulfate	mg/l (0.05)	18	55	
Sodium	mg/l (0.06)	12.0	69	
Potassium	mg/l (0.07)	4.3	59	
Calcium	mg/l (0.04)	22.0	81	
Magnesium	mg/l (0.006)	4.2	59	
Iron	ug/l (0.03)	26	32	

Based upon the average FTSI of 65, water quality is considered fair. Lake Howard can be characterized as a clear to moderately colored (10<color<20 color units), medium hard water, eutrophic to hypereutrophic lake, with high concentrations of total nitrogen. The chemical type of water (predominant ionic composition) is calcium bicarbonate.

Also of note:

- The measured pH was high.

Plots and Trends: Lake surface elevations have been relatively stable over the period of record. Recent measures of water chemistry are within the historic ranges of variability, and no trends are evident. Also shown is a diagram of the relative ionic composition of the lake water.

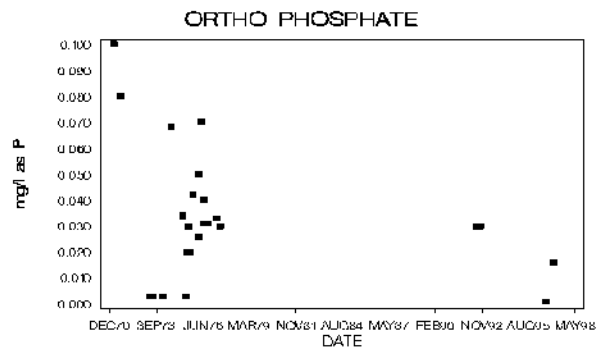
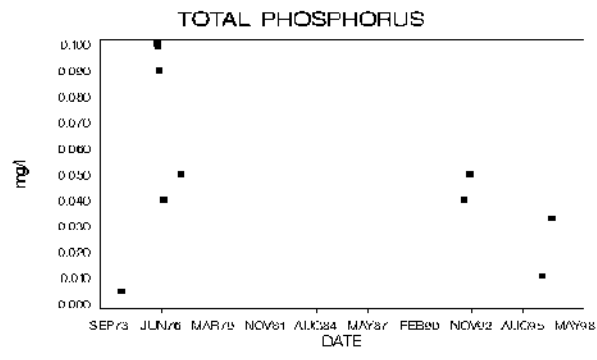
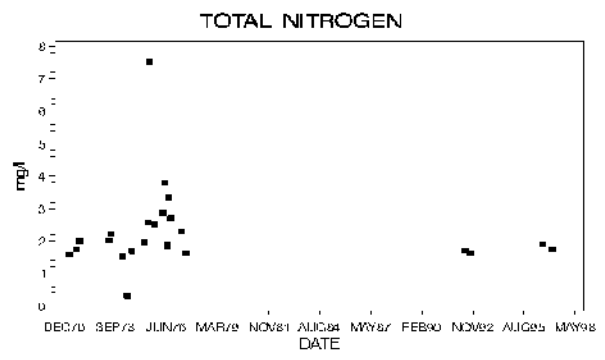
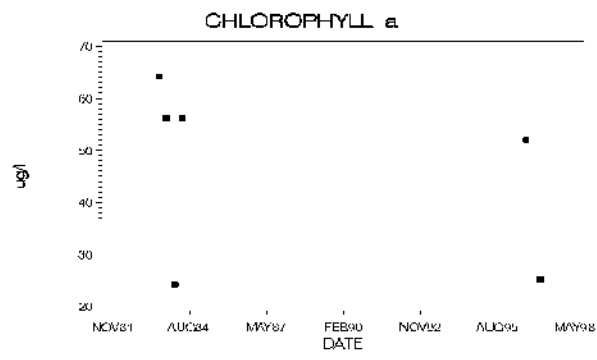
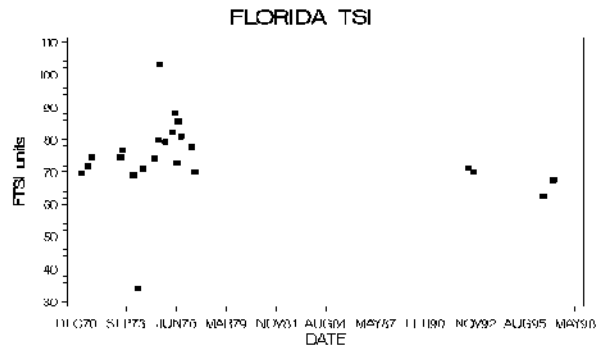
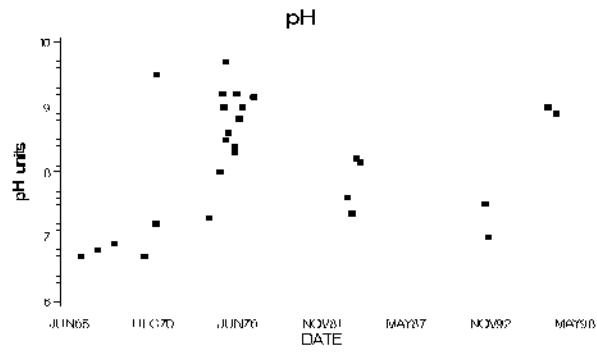
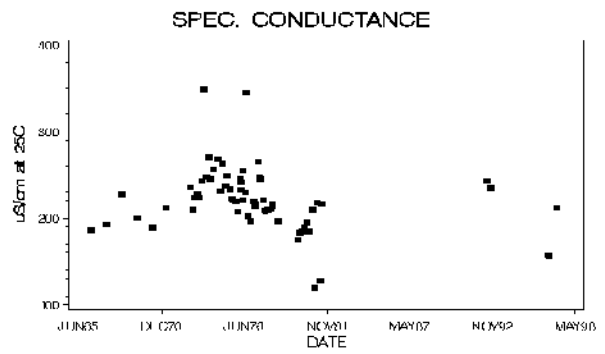
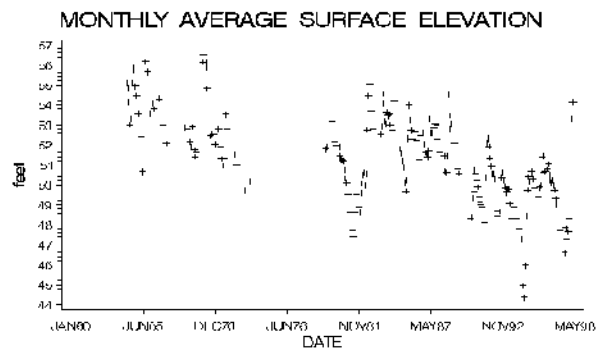

Lake Howard, Polk County

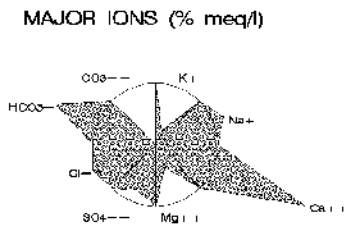
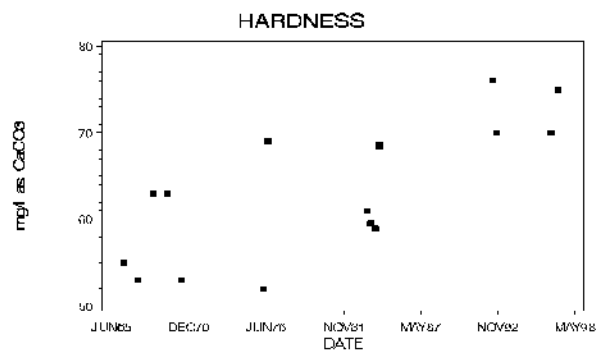
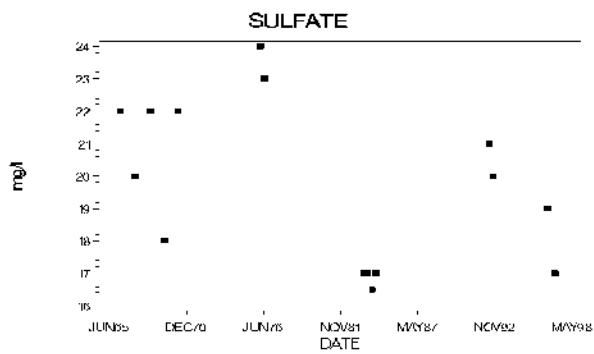
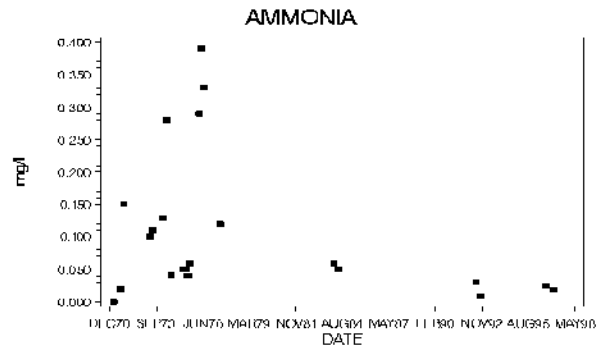
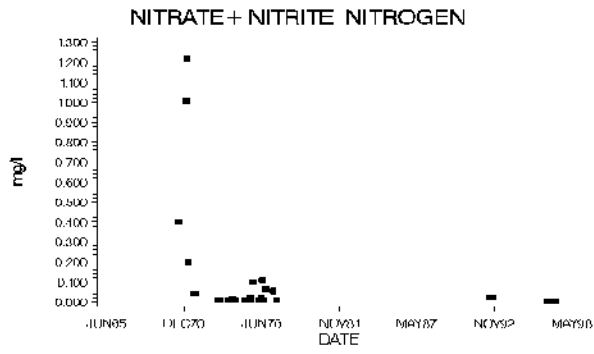
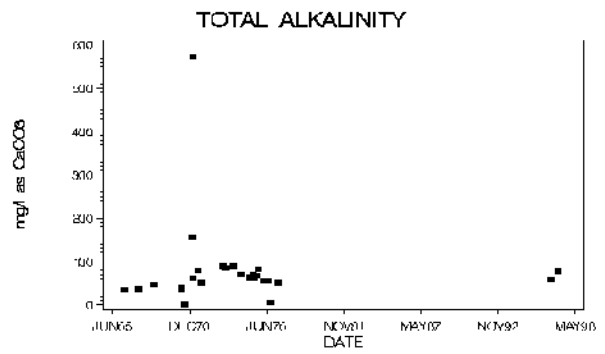
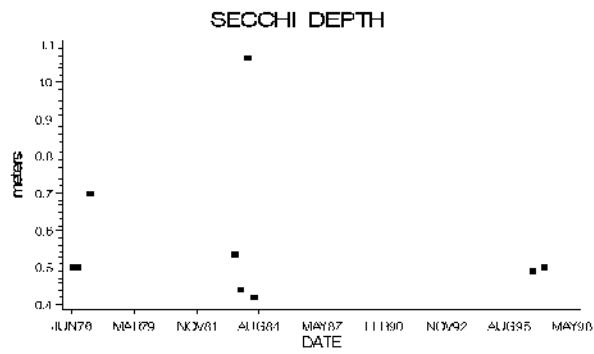

Lake Howard, Polk County

Lake Ida (Frostproof) Polk County

USGS Quadrangle:	Babson Park	Major Land Use/Land Cover (1990)
Section/Township/Range:	28-31S-28E	within 500 meters of the lakeshore:
Approx. Lake Center, Lat/Long:	274544/813118	- tree crops, typically citrus (80%)
Surface Area:	83 acres	- stream and lake swamps (7%)
Approx. Lake Elevation:	79 feet	- medium density residential (6%)
Average Depth: 8.8 feet		
Observed Maximum Depth: 14 feet		
(reference elevation 78.2 feet)		
Lake Type: outflow (type 2)		
Major Basin: Kissimmee Ridge		
Minor Basin: Reedy Creek		
Lake Region: Northern Lake Wales Ridge		

Total Number of Samples Collected: 2 Most Recent Sample Collected: January 1995

Parameter	Units (Detection Limit)	Average Value	District Percentile	Florida Percentile
Chlorophyll a	ug/l (1)	13.7	72	44
Total Phosphorus	mg/l as P (0.01)	0.017	58	9
Total Nitrogen	mg/l as N (0.06)	6.22	>95	>95
Transparency (Secchi depth)	meters	1.00	35	63
Florida Trophic State Index		48	70	30
Specific Conductance	S/cm at 25C (1)	296	87	68
pH	standard units (0.1)	7.0	34	30
Color	PtCo units (1)	10	34	10
Turbidity	NTU (1)	6.1	78	56
Total Alkalinity	mg/l as CaCO3 (1)	35	66	53
Hardness	mg/l as CaCO3 (0.02)	107	92	
Total Suspended Solids	mg/l (0.05)	6.0	82	
Ammonia	mg/l as N (0.03)	0.015	60	
Nitrate+Nitrite	mg/l as N (0.01)	4.789	>95	
Total Kjeldahl Nitrogen	mg/l as N (0.06)	1.43	76	
Orthophosphorus	mg/l as P (0.01)	0.015	80	
Chloride	mg/l (0.05)	21	61	
Sulfate	mg/l (0.05)	48	92	
Sodium	mg/l (0.06)	7.4	37	
Potassium	mg/l (0.07)	8.8	88	
Calcium	mg/l (0.04)	20.5	77	
Magnesium	mg/l (0.006)	13.5	94	
Iron	ug/l (0.03)	61	68	

Based upon the average FTSI of 48, water quality is considered good. Lake Ida (Frostproof) can be characterized as a clear (color<=10 color units), medium hard water, meso-eutrophic lake, with high concentrations of total nitrogen, very high nitrate concentrations. The chemical type of water (predominant ionic composition) is calcium sulfate.

Plots and Trends: No or insufficient data available for plotting or trend detection. Shown is a diagram of the relative ionic composition of the lake water.

MAJOR IONS (% meq/l)

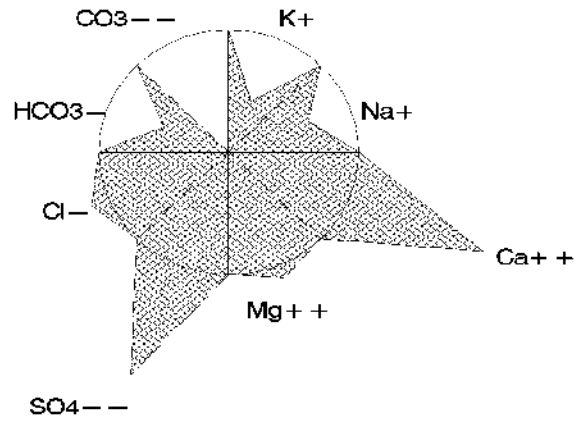

Lake Ida (Frostproof), Polk County

Lake Ida (Winter Haven) Polk County

USGS Quadrangle:	Winter Haven	Major Land Use/Land Cover (1990)
Section/Township/Range:	17-28S-26E	within 500 meters of the lakeshore:
Approx. Lake Center, Lat/Long:	280302/814359	- commercial and services (34%)
Surface Area:	17 acres	- medium density residential (31%)
Approx. Lake Elevation:	135 feet	- utilities (14%)
Average Depth: 9.3 feet		
Observed Maximum Depth: 15 feet		
(reference elevation 134.6 feet)		
Lake Type: inflow and outflow (type 3)		
Major Basin: Peace River		
Minor Basin: Lake Fannie Outlet		
Lake Region: Winter Haven/Lake Henry Ridges		

Total Number of Samples Collected: 2 Most Recent Sample Collected: January 1995

Parameter	Units (Detection Limit)	Average Value	District Percentile	Florida Percentile
Chlorophyll a	ug/l (1)	22.5	81	55
Total Phosphorus	mg/l as P (0.01)	0.103	94	68
Total Nitrogen	mg/l as N (0.06)	1.29	60	45
Transparency (Secchi depth)	meters	1.03	36	64
Florida Trophic State Index		58	81	50
Specific Conductance	S/cm at 25C (1)	231	71	57
pH	standard units (0.1)	7.1	38	35
Color	PtCo units (1)	25	62	20
Turbidity	NTU (1)	3.3	65	35
Total Alkalinity	mg/l as CaCO3 (1)	68	91	72
Hardness	mg/l as CaCO3 (0.02)	91	87	
Total Suspended Solids	mg/l (0.05)	4.7	77	
Ammonia	mg/l as N (0.03)	0.027	60	
Nitrate+Nitrite	mg/l as N (0.01)	0.037	63	
Total Kjeldahl Nitrogen	mg/l as N (0.06)	1.25	65	
Orthophosphorus	mg/l as P (0.01)	0.005	56	
Chloride	mg/l (0.05)	14	30	
Sulfate	mg/l (0.05)	18	55	
Sodium	mg/l (0.06)	7.7	41	
Potassium	mg/l (0.07)	6.2	74	
Calcium	mg/l (0.04)	30.5	93	
Magnesium	mg/l (0.006)	3.5	52	
Iron	ug/l (0.03)	21	22	

Based upon the average FTSI of 58, water quality is considered good. Lake Ida (Winter Haven) can be characterized as a moderately colored, medium hard water, eutrophic lake, with high concentrations of total phosphorus. The chemical type of water (predominant ionic composition) is calcium bicarbonate.

Plots and Trends: No or insufficient data available for plotting or trend detection. Shown is a diagram of the relative ionic composition of the lake water.

MAJOR IONS (% meq/l)

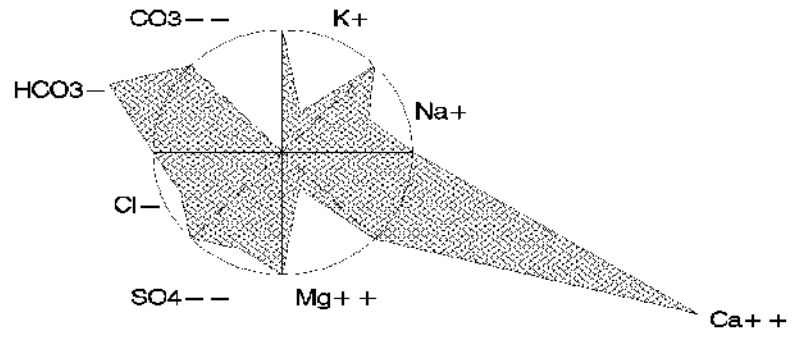

Lake Ida (Winter Haven), Polk County

Lake Idyl

Polk County

USGS Quadrangle: Winter Haven Major Land Use/Land Cover (1990)
 Section/Township/Range: 16-28S-26E within 500 meters of the lakeshore:
 Approx. Lake Center, Lat/Long: 280229/814247 - medium density residential (50%)
 Surface Area: 20 acres - tree crops, typically citrus (28%)
 Approx. Lake Elevation: 134 feet - institutional (12%)
 Average Depth: 6.8 feet
 Observed Maximum Depth: 12 feet
 (reference elevation 132.5 feet)
 Lake Type: inflow and outflow (type 3)
 Major Basin: Peace River
 Minor Basin: Lake Fannie Outlet
 Lake Region: Winter Haven/Lake Henry Ridges

Total Number of Samples Collected: 2 Most Recent Sample Collected: January 1995

Parameter	Units (Detection Limit)	Average Value	District Percentile	Florida Percentile
Chlorophyll a	ug/l (1)	40.4	92	75
Total Phosphorus	mg/l as P (0.01)	0.049	86	40
Total Nitrogen	mg/l as N (0.06)	1.93	83	80
Transparency (Secchi depth)	meters	0.58	14	28
Florida Trophic State Index		70	95	81
Specific Conductance	S/cm at 25C (1)	258	79	61
pH	standard units (0.1)	7.2	43	40
Color	PtCo units (1)	13	41	12
Turbidity	NTU (1)	16.6	95	78
Total Alkalinity	mg/l as CaCO3 (1)	52	81	63
Hardness	mg/l as CaCO3 (0.02)	89	86	
Total Suspended Solids	mg/l (0.05)	11.9	93	
Ammonia	mg/l as N (0.03)	0.015	60	
Nitrate+Nitrite	mg/l as N (0.01)	0.231	88	
Total Kjeldahl Nitrogen	mg/l as N (0.06)	1.70	83	
Orthophosphorus	mg/l as P (0.01)	0.016	82	
Chloride	mg/l (0.05)	20	56	
Sulfate	mg/l (0.05)	31	79	
Sodium	mg/l (0.06)	10.3	60	
Potassium	mg/l (0.07)	7.5	84	
Calcium	mg/l (0.04)	27.0	89	
Magnesium	mg/l (0.006)	5.3	72	
Iron	ug/l (0.03)	18	15	

Based upon the average FTSI of 70, water quality is considered fair. Lake Idyl can be characterized as a clear to moderately colored (10<color<20 color units), medium hard water, hypereutrophic lake, with high concentrations of total phosphorus and high concentrations of total nitrogen. The chemical type of water (predominant ionic composition) is calcium sulfate.

Plots and Trends: No or insufficient data available for plotting or trend detection. Shown is a diagram of the relative ionic composition of the lake water.

MAJOR IONS (% meq/l)

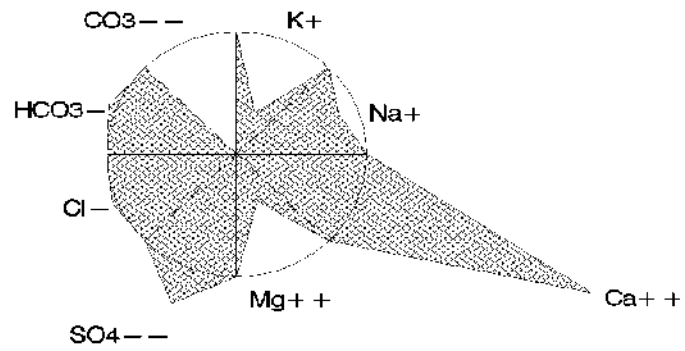

Idylwild Lake

Polk County

USGS Quadrangle: Auburndale Major Land Use/Land Cover (1990)
 Section/Township/Range: 18-28S-26E within 500 meters of the lakeshore:
 Approx. Lake Center, Lat/Long: 280302/814523 - medium density residential (29%)
 Surface Area: 102 acres - high density residential (17%)
 Approx. Lake Elevation: 132 feet - transportation (16%)
 Average Depth: 7.4 feet
 Observed Maximum Depth: 10 feet
 (reference elevation 130 feet)
 Lake Type: inflow and outflow (type 3)
 Major Basin: Peace River
 Minor Basin: Lake Lulu Outlet
 Lake Region: Winter Haven/Lake Henry Ridges
 Public Access: yes

Total Number of Samples Collected: 2 Most Recent Sample Collected: February 1997

Parameter	Units (Detection Limit)	Average Value	District Percentile	Florida Percentile
Chlorophyll a	ug/l (1)	40.1	91	75
Total Phosphorus	mg/l as P (0.01)	0.026	73	16
Total Nitrogen	mg/l as N (0.06)	1.29	60	45
Transparency (Secchi depth)	meters	0.75	21	45
Florida Trophic State Index		61	85	57
Specific Conductance	S/cm at 25C (1)	196	57	51
pH	standard units (0.1)	8.7	93	88
Color	PtCo units (1)	13	41	12
Turbidity	NTU (1)	8.0	83	63
Total Alkalinity	mg/l as CaCO3 (1)	56	84	66
Hardness	mg/l as CaCO3 (0.02)	71	73	
Total Suspended Solids	mg/l (0.05)	6.3	83	
Ammonia	mg/l as N (0.03)	0.015	60	
Nitrate+Nitrite	mg/l as N (0.01)	0.005	33	
Total Kjeldahl Nitrogen	mg/l as N (0.06)	1.29	68	
Orthophosphorus	mg/l as P (0.01)	0.008	56	
Chloride	mg/l (0.05)	19	51	
Sulfate	mg/l (0.05)	22	65	
Sodium	mg/l (0.06)	13.0	76	
Potassium	mg/l (0.07)	5.5	70	
Calcium	mg/l (0.04)	20.0	75	
Magnesium	mg/l (0.006)	5.2	71	
Iron	ug/l (0.03)	28	35	

Based upon the average FTSI of 61, water quality is considered fair. Idylwild Lake can be characterized as a clear to moderately colored (10<color<20 color units), medium hard water, eutrophic to hypereutrophic lake. The chemical type of water (predominant ionic composition) is calcium bicarbonate.

Also of note:

- The measured pH was high.

Plots and Trends: The plots of water chemistry show that water chemistry is similar now to what as measured during the 1970s and 1980s. Also shown is a diagram of the relative ionic composition of the lake water.

Lake Isabell

Polk County

USGS Quadrangle: Lake Arbuckle Major Land Use/Land Cover (1990)
 Section/Township/Range: 36-32S-28E within 500 meters of the lakeshore:
 Approx. Lake Center, Lat/Long: 273858/812837 - tree crops, typically citrus (41%)
 Surface Area: 95 acres - pine flatwoods (16%)
 Approx. Lake Elevation: 93 feet - cropland and pastureland (13%)
 Lake Type: inflow and outflow (type 3)
 Major Basin: Kissimmee Ridge
 Minor Basin: Grassy Creek
 Lake Region: Lake Wales Ridge Transition

Total Number of Samples Collected: 2 Most Recent Sample Collected: January 1995

Parameter	Units (Detection Limit)	Average Value	District Percentile	Florida Percentile
Chlorophyll a	ug/l (1)	9.2	60	36
Total Phosphorus	mg/l as P (0.01)	0.028	75	18
Total Nitrogen	mg/l as N (0.06)	0.84	28	27
Transparency (Secchi depth)	meters	0.98	33	63
Florida Trophic State Index		50	74	36
Specific Conductance	S/cm at 25C (1)	193	56	51
pH	standard units (0.1)	7.2	43	40
Color	PtCo units (1)	93	88	74
Turbidity	NTU (1)	6.2	79	56
Total Alkalinity	mg/l as CaCO3 (1)	23	46	42
Hardness	mg/l as CaCO3 (0.02)	64	67	
Total Suspended Solids	mg/l (0.05)	5.1	79	
Ammonia	mg/l as N (0.03)	0.015	60	
Nitrate+Nitrite	mg/l as N (0.01)	0.095	81	
Total Kjeldahl Nitrogen	mg/l as N (0.06)	0.74	28	
Orthophosphorus	mg/l as P (0.01)	0.020	85	
Chloride	mg/l (0.05)	22	64	
Sulfate	mg/l (0.05)	26	72	
Sodium	mg/l (0.06)	5.9	21	
Potassium	mg/l (0.07)	9.9	90	
Calcium	mg/l (0.04)	10.4	39	
Magnesium	mg/l (0.006)	9.3	86	
Iron	ug/l (0.03)	62	69	

Based upon the average FTSI of 50, water quality is considered good. Lake Isabell can be characterized as a highly colored, medium hard water, meso-eutrophic lake. The chemical type of water (predominant ionic composition) is calcium chloride (2 samples) or calcium sulfate (1 sample).

Plots and Trends: No or insufficient data available for plotting or trend detection. Shown is a diagram of the relative ionic composition of the lake water.

MAJOR IONS (% meq/l)

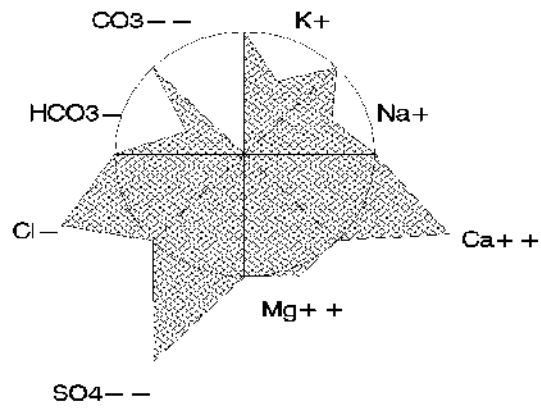

Lake Isabell, Polk County

Lake Jessie

Polk County

USGS Quadrangle: Auburndale Major Land Use/Land Cover (1990)
 Section/Township/Range: 12-28S-25E within 500 meters of the lakeshore:
 Approx. Lake Center, Lat/Long: 280328/814549 - transportation (28%)
 Surface Area: 190 acres - medium density residential (22%)
 Approx. Lake Elevation: 132 feet - high density residential (17%)
 Average Depth: 8.1 feet
 Observed Maximum Depth: 12 feet
 (reference elevation 130 feet)
 Lake Type: inflow and outflow (type 3)
 Major Basin: Peace River
 Minor Basin: Lake Lulu Outlet
 Lake Region: Winter Haven/Lake Henry Ridges
 Public Access: yes

Total Number of Samples Collected: 2 Most Recent Sample Collected: February 1997

Parameter	Units (Detection Limit)	Average Value	District Percentile	Florida Percentile
Chlorophyll a	ug/l (1)	48.6	94	81
Total Phosphorus	mg/l as P (0.01)	0.033	79	23
Total Nitrogen	mg/l as N (0.06)	1.27	59	44
Transparency (Secchi depth)	meters	0.65	17	35
Florida Trophic State Index		65	91	67
Specific Conductance	S/cm at 25C (1)	213	64	54
pH	standard units (0.1)	8.8	95	90
Color	PtCo units (1)	13	41	12
Turbidity	NTU (1)	10.1	88	70
Total Alkalinity	mg/l as CaCO3 (1)	54	82	64
Hardness	mg/l as CaCO3 (0.02)	71	73	
Total Suspended Solids	mg/l (0.05)	8.5	88	
Ammonia	mg/l as N (0.03)	0.015	60	
Nitrate+Nitrite	mg/l as N (0.01)	0.005	33	
Total Kjeldahl Nitrogen	mg/l as N (0.06)	1.27	66	
Orthophosphorus	mg/l as P (0.01)	0.008	56	
Chloride	mg/l (0.05)	18	46	
Sulfate	mg/l (0.05)	24	69	
Sodium	mg/l (0.06)	13.5	78	
Potassium	mg/l (0.07)	5.7	71	
Calcium	mg/l (0.04)	20.0	75	
Magnesium	mg/l (0.006)	5.2	71	
Iron	ug/l (0.03)	40	53	

Based upon the average FTSI of 65, water quality is considered fair. Lake Jessie can be characterized as a clear to moderately colored (10 < color < 20 color units), medium hard water, eutrophic to hypereutrophic lake. The chemical type of water (predominant ionic composition) is calcium bicarbonate.

Also of note:

- The measured pH was high.

Plots and Trends: Plots of Lake Jessie water chemistry show that water chemistry has been widely variable, but no trends are evident. Total phosphorus concentrations for samples collected in 1996 and 1997 were lower than for samples collected in the 1970s, however, total P remains high. Also shown is a diagram of the relative ionic composition of the lake water.

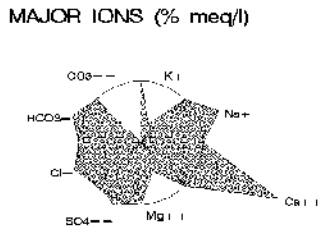
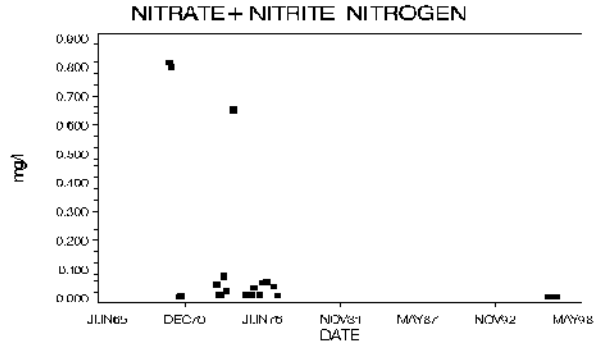
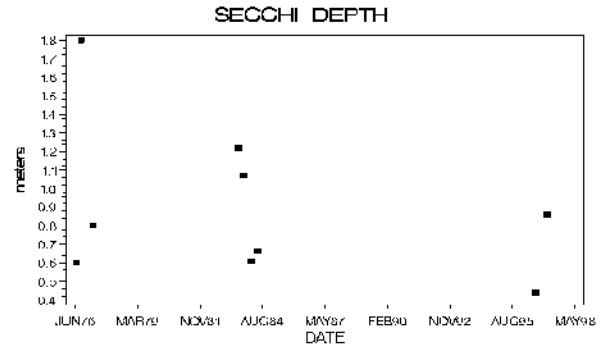
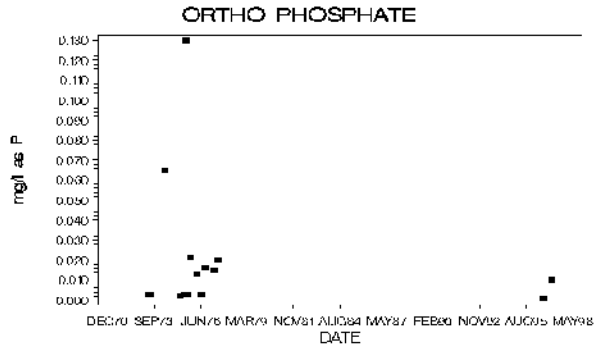
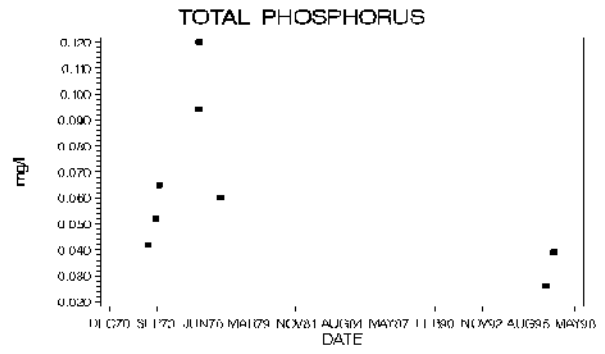
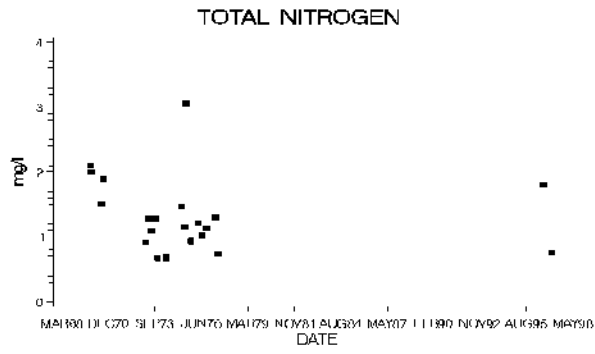
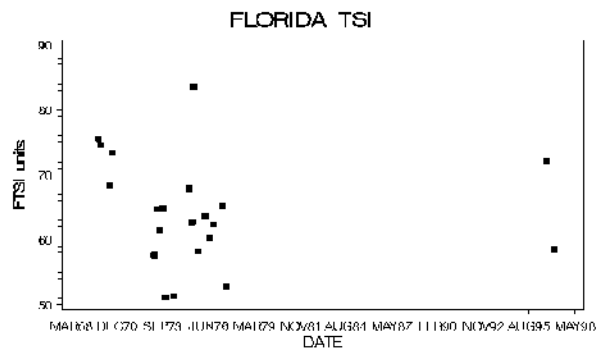
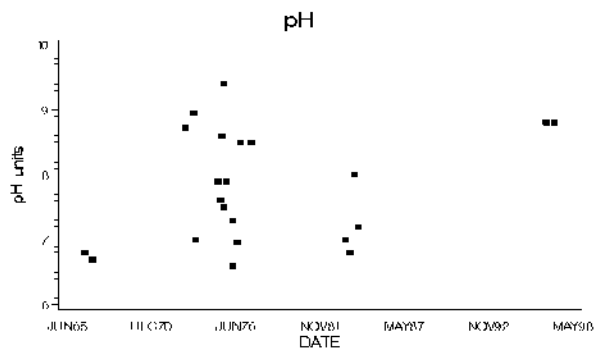

Lake Jessie, Polk County

Lake Juliana

Polk County

USGS Quadrangle: Polk City Major Land Use/Land Cover (1990)
 Section/Township/Range: 15-27S-25E within 500 meters of the lakeshore:
 Approx. Lake Center, Lat/Long: 280750/814812 - other open lands - rural (35%)
 Surface Area: 926 acres - tree crops, typically citrus (27%)
 Approx. Lake Elevation: 133 feet - stream and lake swamps (9%)
 Observed Maximum Depth: 17.1 feet
 (reference elevation not given)
 Lake Type: outflow (type 2)
 Major Basin: Withlacoochee River
 Minor Basin: Lake Juliana Outlet
 Lake Region: Winter Haven/Lake Henry Ridges
 Public Access: yes

Total Number of Samples Collected: 2 Most Recent Sample Collected: January 1997

Parameter	Units (Detection Limit)	Average Value	District Percentile	Florida Percentile
Chlorophyll a	ug/l (1)	27.9	84	62
Total Phosphorus	mg/l as P (0.01)	0.019	63	10
Total Nitrogen	mg/l as N (0.06)	0.87	30	29
Transparency (Secchi depth)	meters	0.97	32	62
Florida Trophic State Index		55	79	45
Specific Conductance	S/cm at 25C (1)	234	74	57
pH	standard units (0.1)	8.7	93	88
Color	PtCo units (1)	10	34	10
Turbidity	NTU (1)	3.7	68	39
Total Alkalinity	mg/l as CaCO3 (1)	31	60	50
Hardness	mg/l as CaCO3 (0.02)	66	69	
Total Suspended Solids	mg/l (0.05)	3.7	70	
Ammonia	mg/l as N (0.03)	0.034	65	
Nitrate+Nitrite	mg/l as N (0.01)	0.005	33	
Total Kjeldahl Nitrogen	mg/l as N (0.06)	0.87	37	
Orthophosphorus	mg/l as P (0.01)	0.009	56	
Chloride	mg/l (0.05)	31	87	
Sulfate	mg/l (0.05)	32	81	
Sodium	mg/l (0.06)	14.5	82	
Potassium	mg/l (0.07)	7.7	85	
Calcium	mg/l (0.04)	9.2	35	
Magnesium	mg/l (0.006)	10.5	88	
Iron	ug/l (0.03)	34	45	

Based upon the average FTSI of 55, water quality is considered good. Lake Juliana can be characterized as a clear (color<=10 color units), medium hard water, eutrophic lake. The chemical type of water (predominant ionic composition) is sodium chloride. Also of note: The measured pH was high.

Plots and Trends: The range in elevation fluctuation over the period of record was about 7 feet. Lake elevation has generally increased over the past decade, but no long-term trend is clear. A trend is suggested by the data for specific conductivity, however, the 15-year gap in the available data makes it difficult to conclude there is a long term trend or change. Similarly, hardness and total alkalinity were greater for samples collected during 1996 and 1997 than for samples collected in the mid to late 1960s, but there are fewer than 10 data points, so conclusions about changes in long-term water chemistry cannot be made. Also shown is a diagram of the relative ionic composition of the lake water.

MONTHLY AVERAGE SURFACE ELEVATION

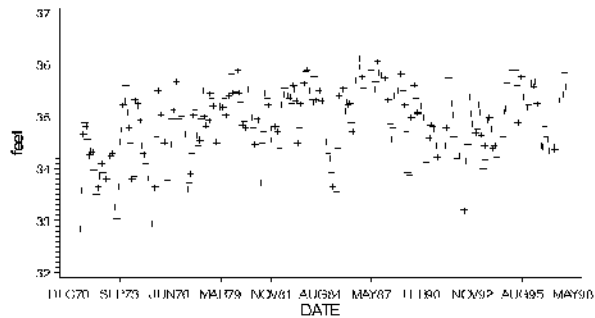

SPEC. CONDUCTANCE

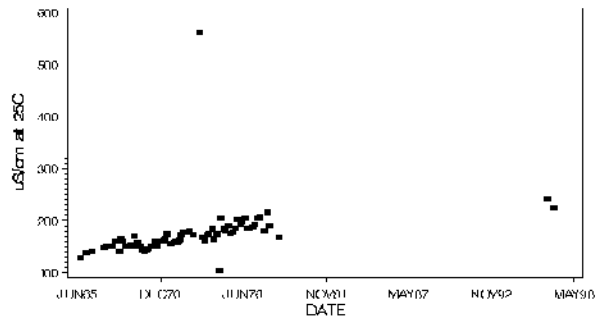

TOTAL ALKALINITY

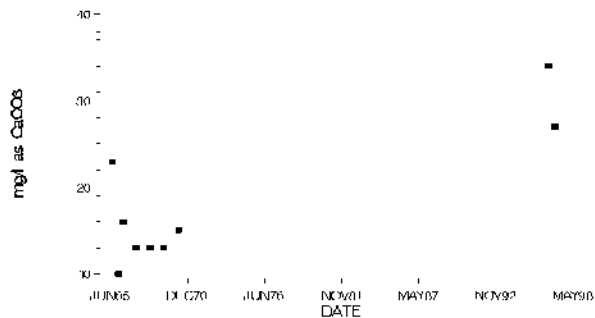

HARDNESS

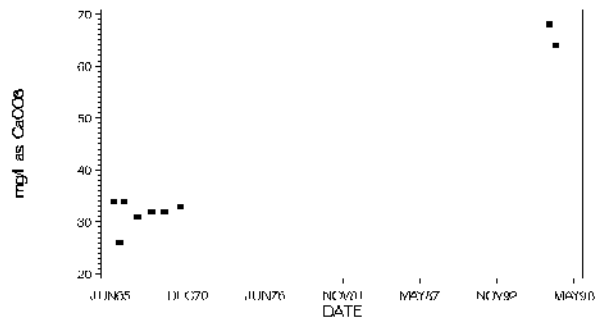

MAJOR IONS (% meq/l)

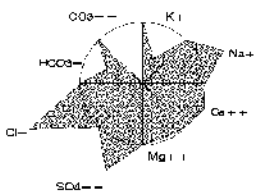

Lake Lena

Polk County

USGS Quadrangle: Auburndale Major Land Use/Land Cover (1990)
 Section/Township/Range: 9-28S-25E within 500 meters of the lakeshore:
 Approx. Lake Center, Lat/Long: 280356/814832 - medium density residential (59%)
 Surface Area: 207 acres - high density residential (13%)
 Approx. Lake Elevation: 137 feet - commercial and services (12%)
 Observed Maximum Depth: 12.5 feet
 (reference elevation not given)
 Lake Type: inflow and outflow (type 3)
 Major Basin: Peace River
 Minor Basin: Lake Lena Run
 Lake Region: Winter Haven/Lake Henry Ridges
 Public Access: yes

Total Number of Samples Collected: 2 Most Recent Sample Collected: January 1997

Parameter	Units (Detection Limit)	Average Value	District Percentile	Florida Percentile
Chlorophyll a	ug/l (1)	31.2	85	66
Total Phosphorus	mg/l as P (0.01)	0.016	56	8
Total Nitrogen	mg/l as N (0.06)	1.25	57	43
Transparency (Secchi depth)	meters	0.57	14	27
Florida Trophic State Index		59	83	53
Specific Conductance	S/cm at 25C (1)	235	74	58
pH	standard units (0.1)	8.9	>95	91
Color	PtCo units (1)	8	24	8
Turbidity	NTU (1)	9.8	87	69
Total Alkalinity	mg/l as CaCO3 (1)	37	69	54
Hardness	mg/l as CaCO3 (0.02)	70	72	
Total Suspended Solids	mg/l (0.05)	8.3	87	
Ammonia	mg/l as N (0.03)	0.015	60	
Nitrate+Nitrite	mg/l as N (0.01)	0.009	33	
Total Kjeldahl Nitrogen	mg/l as N (0.06)	1.25	65	
Orthophosphorus	mg/l as P (0.01)	0.015	80	
Chloride	mg/l (0.05)	23	69	
Sulfate	mg/l (0.05)	37	86	
Sodium	mg/l (0.06)	14.0	80	
Potassium	mg/l (0.07)	5.8	72	
Calcium	mg/l (0.04)	14.5	58	
Magnesium	mg/l (0.006)	8.2	84	
Iron	ug/l (0.03)	19	17	

Based upon the average FTSI of 59, water quality is considered good. Lake Lena can be characterized as a clear (color<=10 color units), medium hard water, eutrophic lake. The chemical type of water (predominant ionic composition) is calcium sulfate.

Also of note:

- The measured pH was high.
- Cattails dominate more than 30% of the lake shoreline.

Plots and Trends: The range in elevation fluctuation over the period of record was under 5 feet. Lake elevation has generally increased over the past decade, but no long-term trend is clear for lake elevation. Recent measurements of total P, total N, and Florida TSI were lower than for their respective measures over the period of record. However, trends in the three variables cannot be concluded. Also shown is a diagram of the relative ionic composition of the lake water.

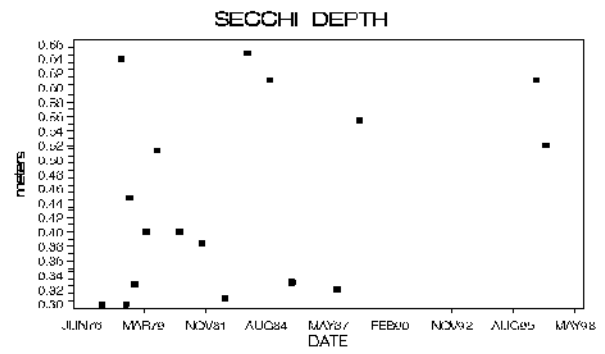
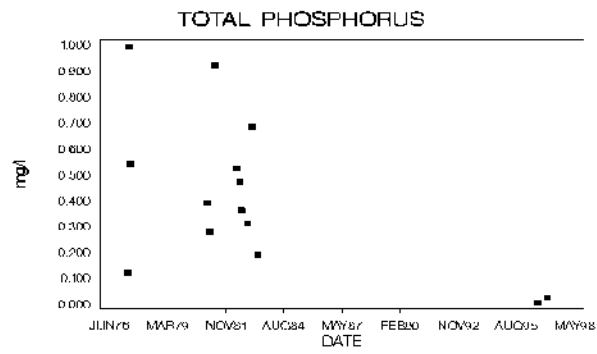
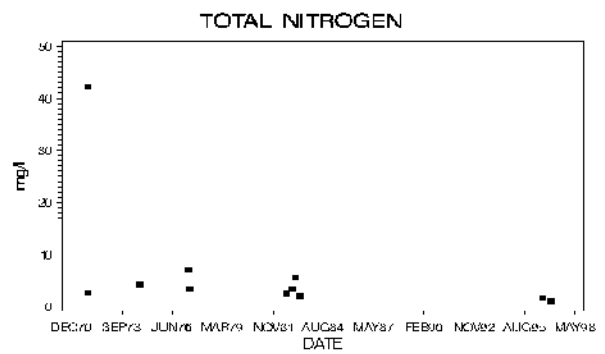
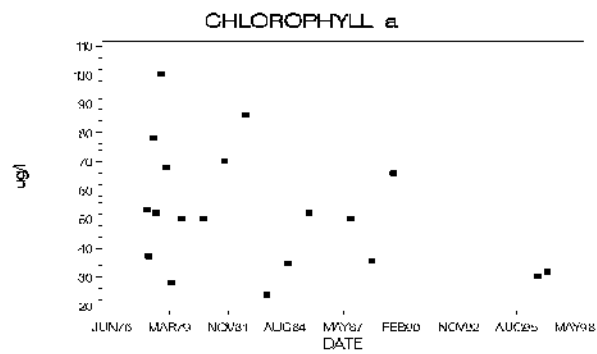
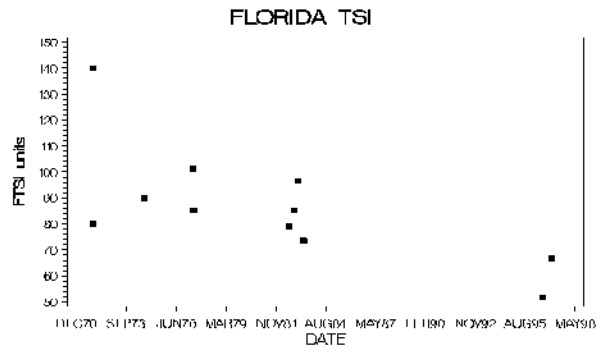
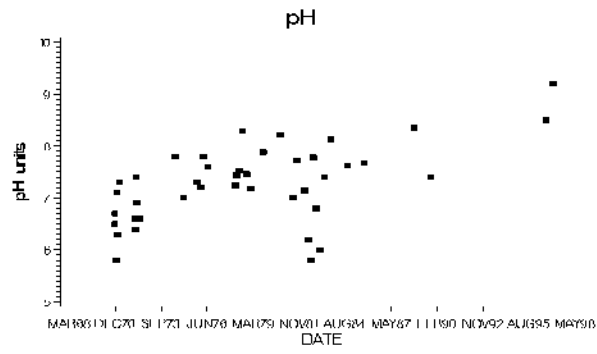
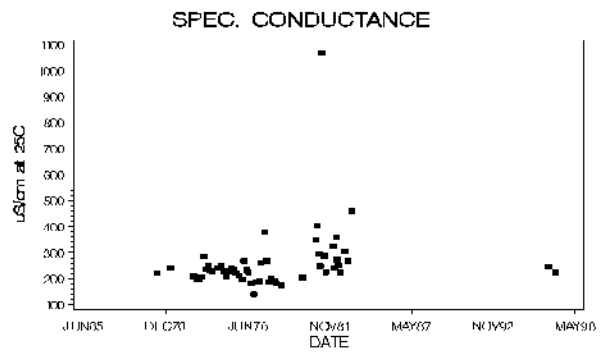
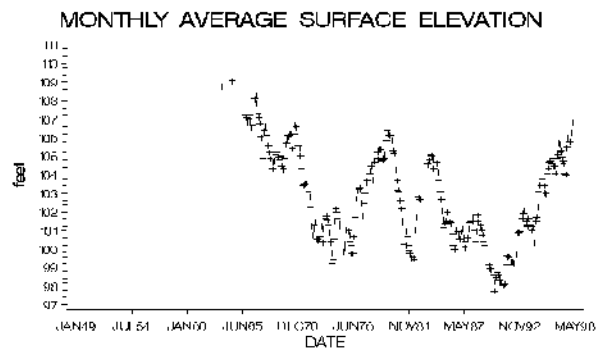

Lake Lena, Polk County

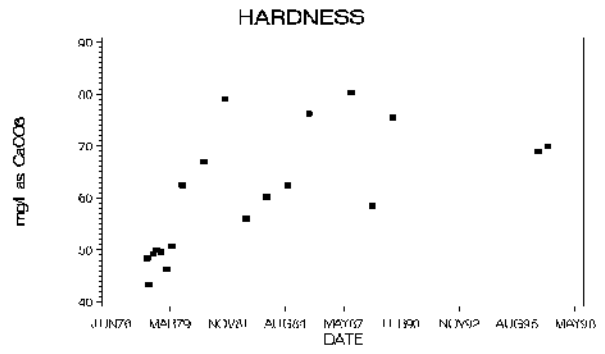
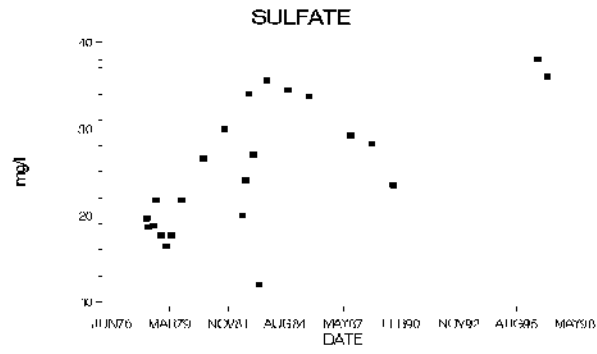
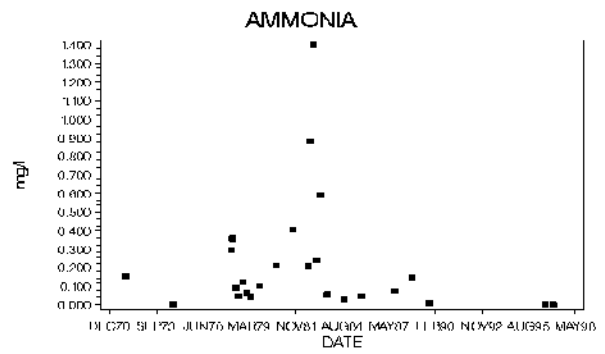
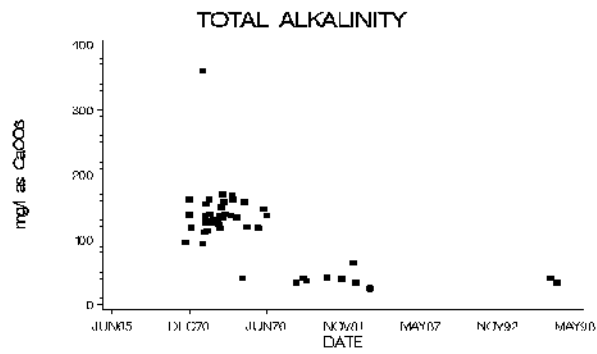

MAJOR IONS (% meq/l)

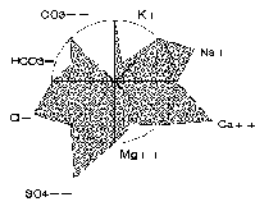

Lake Leonore Polk County

USGS Quadrangle:	Babson Park	Major Land Use/Land Cover (1990)
Section/Township/Range:	10-31S-28E	within 500 meters of the lakeshore:
Approx. Lake Center, Lat/Long:	274745/813044	- tree crops, typically citrus (68%)
Surface Area:	393 acres	- stream and lake swamps (32%)
Approx. Lake Elevation:	87 feet	- freshwater marshes (1%)

Observed Maximum Depth: 8.2 feet
(reference elevation not given)

Lake Type: outflow (type 2)

Major Basin: Kissimmee Ridge

Minor Basin: Lake Weohyakapka

Lake Region: Lake Wales Ridge Transition

Public Access: yes

Total Number of Samples Collected: 2 Most Recent Sample Collected: January 1997

Parameter	Units (Detection Limit)	Average Value	District Percentile	Florida Percentile
Chlorophyll a	ug/l (1)	6.8	52	30
Total Phosphorus	mg/l as P (0.01)	0.005	31	<5
Total Nitrogen	mg/l as N (0.06)	2.85	94	91
Transparency (Secchi depth)	meters	1.88	60	83
Florida Trophic State Index		31	31	6
Specific Conductance	S/cm at 25C (1)	347	92	73
pH	standard units (0.1)	8.1	83	73
Color	PtCo units (1)	10	34	10
Turbidity	NTU (1)	1.8	47	17
Total Alkalinity	mg/l as CaCO3 (1)	49	79	62
Hardness	mg/l as CaCO3 (0.02)	129	95	
Total Suspended Solids	mg/l (0.05)	2.3	56	
Ammonia	mg/l as N (0.03)	0.015	60	
Nitrate+Nitrite	mg/l as N (0.01)	1.850	95	
Total Kjeldahl Nitrogen	mg/l as N (0.06)	1.01	48	
Orthophosphorus	mg/l as P (0.01)	0.008	56	
Chloride	mg/l (0.05)	30	85	
Sulfate	mg/l (0.05)	58	>95	
Sodium	mg/l (0.06)	9.9	58	
Potassium	mg/l (0.07)	12.1	93	
Calcium	mg/l (0.04)	24.1	87	
Magnesium	mg/l (0.006)	16.8	>95	
Iron	ug/l (0.03)	19	17	

Based upon the average FTSI of 31, water quality is considered good. Lake Leonore can be characterized as a clear (color<=10 color units), hard water, mesotrophic lake, with low concentrations of total phosphorus, high concentrations of total nitrogen and high nitrate concentrations. The chemical type of water (predominant ionic composition) is calcium sulfate.

Also of note:

- The measured pH was high.
- Cattails dominate more than 30% of the lake shoreline.

Plots and Trends: Similar to plots of lake elevation for other lakes in the Lake Wales Ridge region, Lake Leonore surface elevations have generally increased during the 1990s, recovering from the drought years in the mid- to late 1980s in the Lake Wales Ridge region. Also shown is a diagram of the relative ionic composition of the lake water.

MONTHLY AVERAGE SURFACE ELEVATION

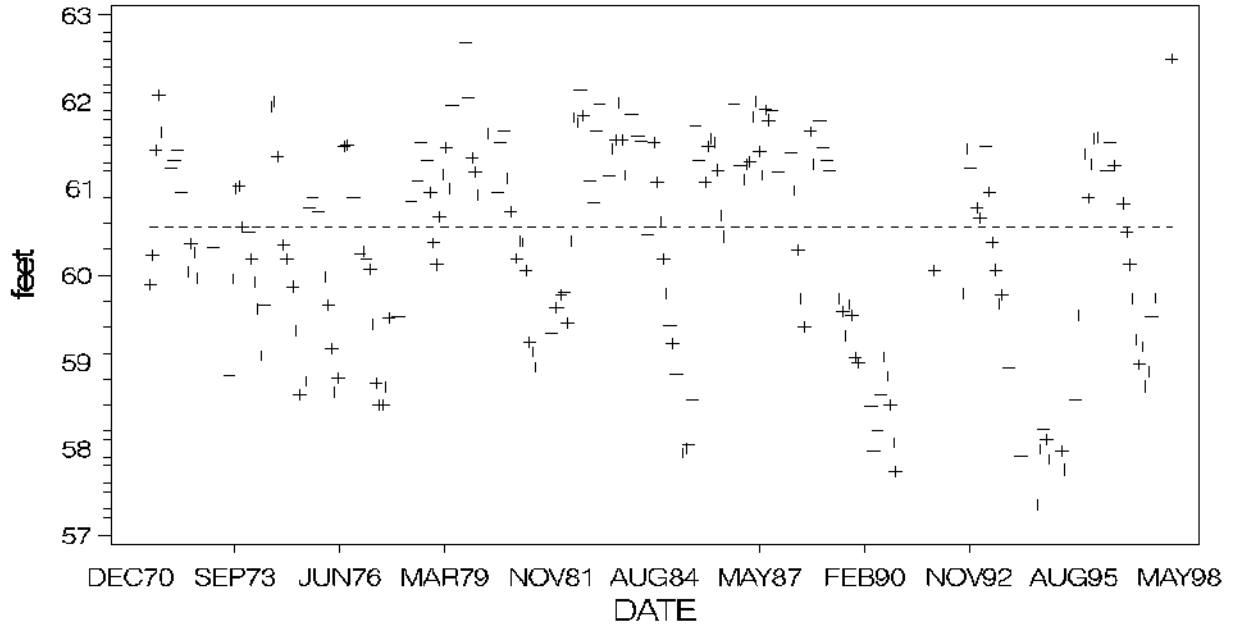

MAJOR IONS (% meq/l)

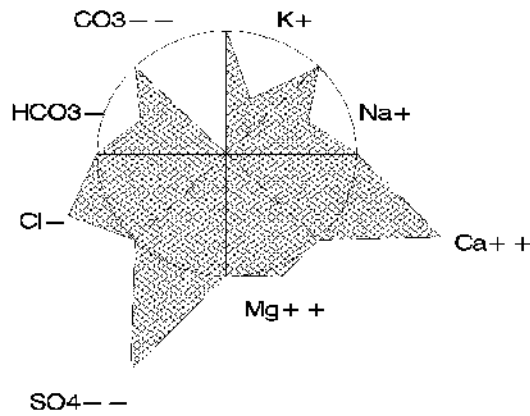

Lester Lake

Polk County

USGS Quadrangle: Lakeland Major Land Use/Land Cover (1990)
 Section/Township/Range: 22-27S-23E within 500 meters of the lakeshore:
 Approx. Lake Center, Lat/Long: 280721/815953 - low density residential (30%)
 Surface Area: 42 acres - stream and lake swamps (17%)
 Approx. Lake Elevation: 128 feet - tree crops, typically citrus (16%)
 Lake Type: inflow (type 1)
 Major Basin: Hillsborough River
 Minor Basin: Kathleen Drain
 Lake Region: Lakeland/Bone Valley Upland

Total Number of Samples Collected: 2 Most Recent Sample Collected: January 1996

Parameter	Units (Detection Limit)	Average Value	District Percentile	Florida Percentile
Chlorophyll a	ug/l (1)	84.5	>95	93
Total Phosphorus	mg/l as P (0.01)	0.079	92	59
Total Nitrogen	mg/l as N (0.06)	2.63	93	89
Transparency (Secchi depth)	meters	0.35	<5	<5
Florida Trophic State Index		78	>95	94
Specific Conductance	S/cm at 25C (1)	142	32	40
pH	standard units (0.1)	8.4	90	80
Color	PtCo units (1)	125	92	85
Turbidity	NTU (1)	24.9	>95	85
Total Alkalinity	mg/l as CaCO3 (1)	22	45	41
Hardness	mg/l as CaCO3 (0.02)	40	36	
Total Suspended Solids	mg/l (0.05)	12.3	93	
Ammonia	mg/l as N (0.03)	0.079	85	
Nitrate+Nitrite	mg/l as N (0.01)	0.074	78	
Total Kjeldahl Nitrogen	mg/l as N (0.06)	2.55	>95	
Orthophosphorus	mg/l as P (0.01)	0.050	94	
Chloride	mg/l (0.05)	21	61	
Sulfate	mg/l (0.05)	7	27	
Sodium	mg/l (0.06)	9.7	57	
Potassium	mg/l (0.07)	4.1	57	
Calcium	mg/l (0.04)	8.6	31	
Magnesium	mg/l (0.006)	4.5	63	
Iron	ug/l (0.03)	108	84	

Based upon the average FTSI of 78, water quality is considered poor. Lester Lake can be characterized as a highly colored, soft water, hypereutrophic lake, with high concentrations of total phosphorus and high concentrations of total nitrogen. The chemical type of water (predominant ionic composition) is calcium chloride (1 sample) or sodium chloride (1 sample).

Also of note:

- The measured pH was high.

Plots and Trends: No or insufficient data available for plotting or trend detection. Shown is a diagram of the relative ionic composition of the lake water.

MAJOR IONS (% meq/l)

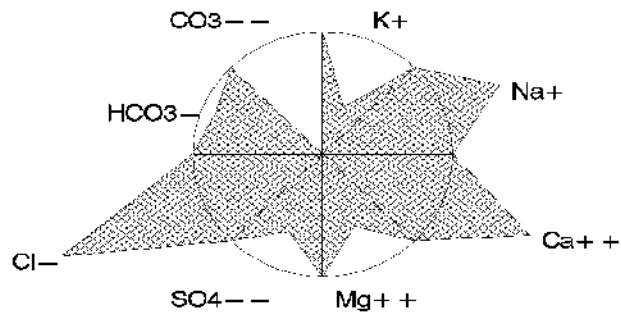

Lester Lake, Polk County

Little Crooked Lake

Polk County

USGS Quadrangle: Babson Park Major Land Use/Land Cover (1990)
 Section/Township/Range: 23-31S-27E within 500 meters of the lakeshore:
 Approx. Lake Center, Lat/Long: 274613/813430 - cropland and pastureland (25%)
 Surface Area: 845 acres - freshwater marshes (17%)
 Approx. Lake Elevation: 118 feet - herbaceous range (13%)
 Observed Maximum Depth: 7 feet
 (reference elevation not given)
 Lake Type: inflow and outflow (type 3)
 Major Basin: Kissimmee Ridge
 Minor Basin: Crooked Lake Outlet
 Lake Region: Southwestern Flatlands
 Public Access: yes

Total Number of Samples Collected: 2 Most Recent Sample Collected: December 1996

Parameter	Units (Detection Limit)	Average Value	District Percentile	Florida Percentile
Chlorophyll a	ug/l (1)	10.8	67	40
Total Phosphorus	mg/l as P (0.01)	0.019	63	10
Total Nitrogen	mg/l as N (0.06)	0.75	23	23
Transparency (Secchi depth)	meters	0.49	8	19
Florida Trophic State Index		54	78	43
Specific Conductance	S/cm at 25C (1)	129	24	35
pH	standard units (0.1)	6.4	12	15
Color	PtCo units (1)	98	89	76
Turbidity	NTU (1)	12.2	91	73
Total Alkalinity	mg/l as CaCO3 (1)	5	13	13
Hardness	mg/l as CaCO3 (0.02)	27	18	
Total Suspended Solids	mg/l (0.05)	5.9	81	
Ammonia	mg/l as N (0.03)	0.027	60	
Nitrate+Nitrite	mg/l as N (0.01)	0.010	34	
Total Kjeldahl Nitrogen	mg/l as N (0.06)	0.74	28	
Orthophosphorus	mg/l as P (0.01)	0.005	56	
Chloride	mg/l (0.05)	21	61	
Sulfate	mg/l (0.05)	16	52	
Sodium	mg/l (0.06)	10.1	59	
Potassium	mg/l (0.07)	4.6	62	
Calcium	mg/l (0.04)	5.1	14	
Magnesium	mg/l (0.006)	3.5	52	
Iron	ug/l (0.03)	226	93	

Based upon the average FTSI of 54, water quality is considered good. Little Crooked Lake can be characterized as a highly colored, soft water, eutrophic lake. The chemical type of water (predominant ionic composition) is sodium chloride.

Also of note:

- Waterhyacinth was observed in the lake.
- Cattails dominate more than 30% of the lake shoreline.

No or insufficient data available for plotting or trend detection. Shown is a diagram of the relative ionic composition of the lake water.

MAJOR IONS (% meq/l)

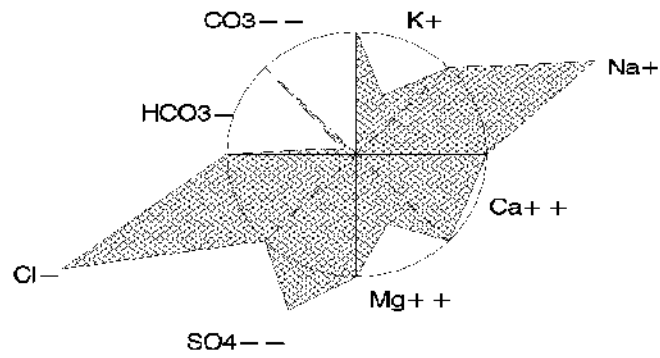

Little Crooked Lake, Polk County

Lake Lulu

Polk County

USGS Quadrangle: Eloise Major Land Use/Land Cover (1990)
 Section/Township/Range: 4-29S-26E within 500 meters of the lakeshore:
 Approx. Lake Center, Lat/Long: 275946/814316 - medium density residential (22%)
 Surface Area: 301 acres - stream and lake swamps (20%)
 Approx. Lake Elevation: 131 feet - commercial and services (16%)
 Average Depth: 6.2 feet
 Observed Maximum Depth: 8 feet
 (reference elevation 130 feet)
 Lake Type: inflow and outflow (type 3)
 Major Basin: Peace River
 Minor Basin: Lake Lulu Outlet
 Lake Region: Winter Haven/Lake Henry Ridges
 Public Access: yes

Total Number of Samples Collected: 2 Most Recent Sample Collected: January 1997

Parameter	Units (Detection Limit)	Average Value	District Percentile	Florida Percentile
Chlorophyll a	ug/l (1)	45.8	93	79
Total Phosphorus	mg/l as P (0.01)	0.041	84	36
Total Nitrogen	mg/l as N (0.06)	1.39	65	50
Transparency (Secchi depth)	meters	0.59	15	29
Florida Trophic State Index		63	87	61
Specific Conductance	S/cm at 25C (1)	245	77	59
pH	standard units (0.1)	8.1	83	73
Color	PtCo units (1)	13	41	12
Turbidity	NTU (1)	11.1	89	71
Total Alkalinity	mg/l as CaCO3 (1)	62	87	69
Hardness	mg/l as CaCO3 (0.02)	82	82	
Total Suspended Solids	mg/l (0.05)	14.7	95	
Ammonia	mg/l as N (0.03)	0.015	60	
Nitrate+Nitrite	mg/l as N (0.01)	0.018	48	
Total Kjeldahl Nitrogen	mg/l as N (0.06)	1.37	72	
Orthophosphorus	mg/l as P (0.01)	0.021	86	
Chloride	mg/l (0.05)	20	56	
Sulfate	mg/l (0.05)	24	69	
Sodium	mg/l (0.06)	13.0	76	
Potassium	mg/l (0.07)	5.5	70	
Calcium	mg/l (0.04)	24.5	87	
Magnesium	mg/l (0.006)	5.0	69	
Iron	ug/l (0.03)	84	76	

Based upon the average FTSI of 63, water quality is considered fair. Lake Lulu can be characterized as a clear to moderately colored (10<color<20 color units), medium hard water, hypereutrophic lake, with high concentrations of total phosphorus. The chemical type of water (predominant ionic composition) is calcium bicarbonate. Also of note: The measured pH was high.

Plots and Trends: Lake Lulu at one time received discharge of domestic and industrial wastewater. Also shown is a diagram of the relative ionic composition of the lake water. Total phosphorus concentrations were very high (1 to 2 mg/l) during the 1970s; total nitrogen concentrations generally ranged between 2 and 6 mg/l. The Florida TSI was consistently in the 'poor' range (FTSI>70) during the 1970s. The samples collected in 1996 and 1997 suggest water quality has improved from the 1970s.

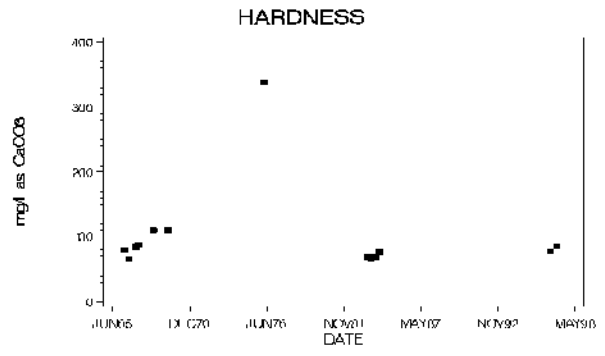
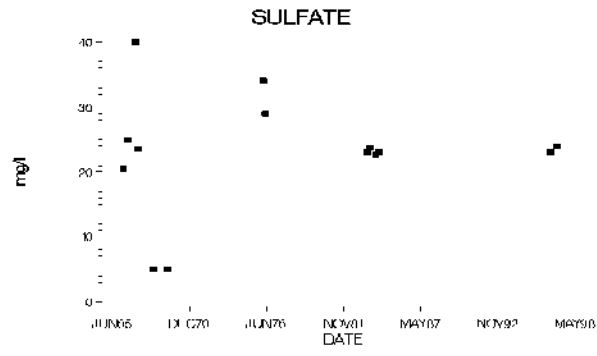
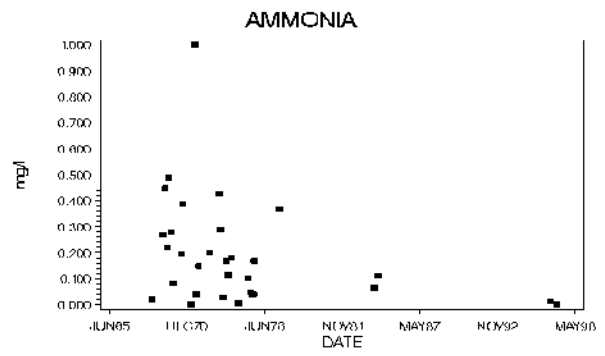
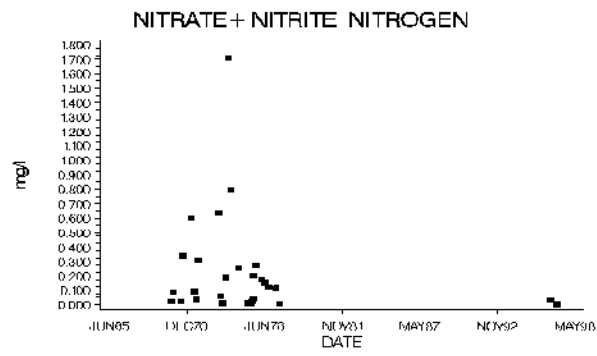

MAJOR IONS (% meq/l)

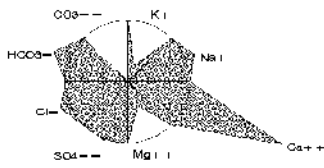

Lake Lulu, Polk County

Lake Mabel

Polk County

USGS Quadrangle: Lake Wales Major Land Use/Land Cover (1990)
 Section/Township/Range: 11-29S-27E within 500 meters of the lakeshore:
 Approx. Lake Center, Lat/Long: 275811/813519 - tree crops, typically citrus (84%)
 Surface Area: 117 acres - other open lands - rural (5%)
 Approx. Lake Elevation: 111 feet - medium density residential (4%)
 Average Depth: 8.5 feet
 Observed Maximum Depth: 15 feet
 (reference elevation 102.4 feet)
 Lake Type: isolated (type 4)
 Major Basin: Peace River
 Minor Basin: Lake Mable
 Lake Region: Northern Lake Wales Ridge

Total Number of Samples Collected: 2 Most Recent Sample Collected: January 1996

Parameter	Units (Detection Limit)	Average Value	District Percentile	Florida Percentile
Chlorophyll a	ug/l (1)	1.7	8	6
Total Phosphorus	mg/l as P (0.01)	0.012	41	6
Total Nitrogen	mg/l as N (0.06)	1.71	75	71
Transparency (Secchi depth)	meters	3.80	92	>95
Florida Trophic State Index		24	11	<5
Specific Conductance	S/cm at 25C (1)	243	76	59
pH	standard units (0.1)	7.4	57	50
Color	PtCo units (1)	8	24	8
Turbidity	NTU (1)	0.8	28	<5
Total Alkalinity	mg/l as CaCO3 (1)	32	62	51
Hardness	mg/l as CaCO3 (0.02)	86	85	
Total Suspended Solids	mg/l (0.05)	0.2	<5	
Ammonia	mg/l as N (0.03)	0.052	76	
Nitrate+Nitrite	mg/l as N (0.01)	0.527	91	
Total Kjeldahl Nitrogen	mg/l as N (0.06)	1.18	61	
Orthophosphorus	mg/l as P (0.01)	0.011	64	
Chloride	mg/l (0.05)	17	41	
Sulfate	mg/l (0.05)	44	91	
Sodium	mg/l (0.06)	7.0	33	
Potassium	mg/l (0.07)	10.0	90	
Calcium	mg/l (0.04)	17.5	67	
Magnesium	mg/l (0.006)	10.3	87	
Iron	ug/l (0.03)	30	39	

Based upon the average FTSI of 24, water quality is considered good. Lake Mabel can be characterized as a clear (color<=10 color units), medium hard water, oligotrophic lake. The chemical type of water (predominant ionic composition) is calcium sulfate.

Plots and Trends: No or insufficient data available for plotting or trend detection. Shown is a diagram of the relative ionic composition of the lake water.

MAJOR IONS (% meq/l)

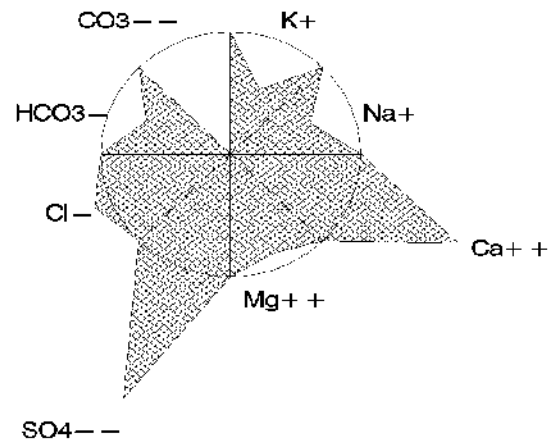

Lake Mabel, Polk County

Lake Mattie

Polk County

USGS Quadrangle: Polk City Major Land Use/Land Cover (1990)
 Section/Township/Range: 14-27S-25E within 500 meters of the lakeshore:
 Approx. Lake Center, Lat/Long: 280810/814647 - freshwater marshes (44%)
 Surface Area: 1078 acres - tree crops, typically citrus (29%)
 Approx. Lake Elevation: 133 feet - stream and lake swamps (18%)
 Average Depth: 9.8 feet
 (reference elevation not given)
 Lake Type: inflow (type 1)
 Major Basin: Withlacoochee River
 Minor Basin: Lake Mattie Outlet
 Lake Region: Southwestern Flatlands
 Public Access: yes

Total Number of Samples Collected: 2 Most Recent Sample Collected: January 1997

Parameter	Units (Detection Limit)	Average Value	District Percentile	Florida Percentile
Chlorophyll a	ug/l (1)	45.6	92	79
Total Phosphorus	mg/l as P (0.01)	0.052	87	41
Total Nitrogen	mg/l as N (0.06)	1.28	59	44
Transparency (Secchi depth)	meters	0.54	12	24
Florida Trophic State Index		70	95	82
Specific Conductance	S/cm at 25C (1)	192	56	51
pH	standard units (0.1)	8.3	87	78
Color	PtCo units (1)	150	94	91
Turbidity	NTU (1)	8.5	84	65
Total Alkalinity	mg/l as CaCO3 (1)	13	32	31
Hardness	mg/l as CaCO3 (0.02)	37	30	
Total Suspended Solids	mg/l (0.05)	5.7	80	
Ammonia	mg/l as N (0.03)	0.015	60	
Nitrate+Nitrite	mg/l as N (0.01)	0.005	33	
Total Kjeldahl Nitrogen	mg/l as N (0.06)	1.28	67	
Orthophosphorus	mg/l as P (0.01)	0.020	85	
Chloride	mg/l (0.05)	35	92	
Sulfate	mg/l (0.05)	20	61	
Sodium	mg/l (0.06)	16.5	87	
Potassium	mg/l (0.07)	9.1	89	
Calcium	mg/l (0.04)	4.4	10	
Magnesium	mg/l (0.006)	6.3	78	
Iron	ug/l (0.03)	142	87	

Based upon the average FTSI of 70, water quality is considered poor. Lake Mattie can be characterized as a highly colored, soft water, hypereutrophic lake, with high concentrations of total phosphorus. The chemical type of water (predominant ionic composition) is sodium chloride.

Also of note:

- The measured pH was high -
- Cattails dominate more than 30% of the lake shoreline.

Plots and Trends: No or insufficient data available for plotting or trend detection. Shown is a diagram of the relative ionic composition of the lake water.

MAJOR IONS (% meq/l)

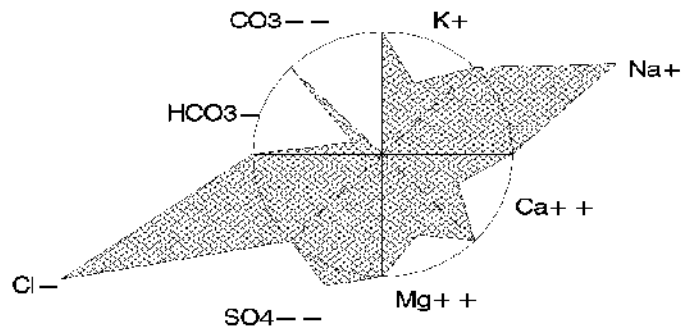

Lake Mattie, Polk County

Lake May

Polk County

USGS Quadrangle:	Winter Haven	Major Land Use/Land Cover (1990)
Section/Township/Range:	29-28S-26E	within 500 meters of the lakeshore:
Approx. Lake Center, Lat/Long:	280047/814413	- medium density residential (35%)
Surface Area:	44 acres	- commercial and services (23%)
Approx. Lake Elevation:	132 feet	- industrial (21%)
Average Depth: 4.5 feet		
Observed Maximum Depth: 6 feet		
(reference elevation 130 feet)		
Lake Type: inflow and outflow (type 3)		
Major Basin: Peace River		
Minor Basin: Lake Lulu Outlet		
Lake Region: Winter Haven/Lake Henry Ridges		
Public Access: yes		

Total Number of Samples Collected: 2 Most Recent Sample Collected: January 1997

Parameter	Units (Detection Limit)	Average Value	District Percentile	Florida Percentile
Chlorophyll a	ug/l (1)	57.9	95	85
Total Phosphorus	mg/l as P (0.01)	0.027	74	17
Total Nitrogen	mg/l as N (0.06)	1.75	77	73
Transparency (Secchi depth)	meters	0.47	6	16
Florida Trophic State Index		64	89	64
Specific Conductance	S/cm at 25C (1)	227	69	56
pH	standard units (0.1)	8.3	87	78
Color	PtCo units (1)	15	46	13
Turbidity	NTU (1)	14.2	93	75
Total Alkalinity	mg/l as CaCO3 (1)	62	87	69
Hardness	mg/l as CaCO3 (0.02)	77	77	
Total Suspended Solids	mg/l (0.05)	16.2	>95	
Ammonia	mg/l as N (0.03)	0.015	60	
Nitrate+Nitrite	mg/l as N (0.01)	0.022	54	
Total Kjeldahl Nitrogen	mg/l as N (0.06)	1.73	83	
Orthophosphorus	mg/l as P (0.01)	0.028	89	
Chloride	mg/l (0.05)	18	46	
Sulfate	mg/l (0.05)	19	58	
Sodium	mg/l (0.06)	12.0	69	
Potassium	mg/l (0.07)	4.4	60	
Calcium	mg/l (0.04)	24.0	86	
Magnesium	mg/l (0.006)	4.2	59	
Iron	ug/l (0.03)	39	52	

Based upon the average FTSI of 64, water quality is considered fair. Lake May can be characterized as a clear to moderately colored (10<color<20 color units), medium hard water, hypereutrophic lake. The chemical type of water (predominant ionic composition) is calcium bicarbonate.

Also of note:

- The measured pH was high.

Plots and Trends: There are few historical data for Lake May. Recent concentrations of Chlorophyll a, total nitrogen, and total alkalinity in Lake May were within the ranges of those measures for samples collected in the 1970s and 1980s. Also shown is a diagram of the relative ionic composition of the lake water.

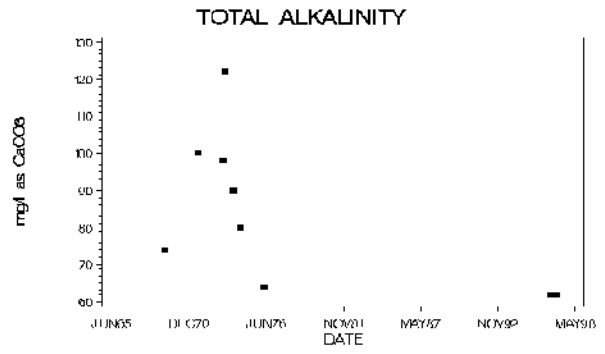
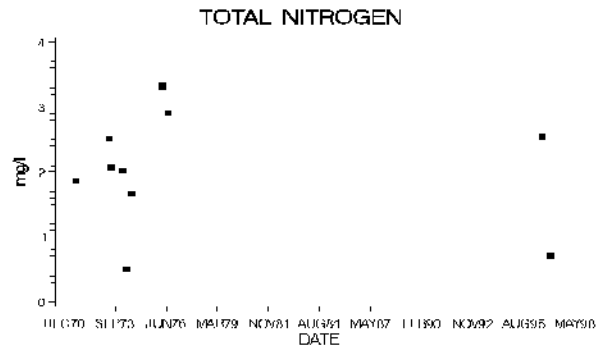
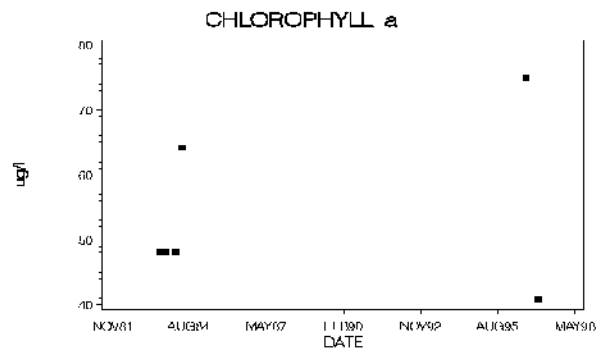
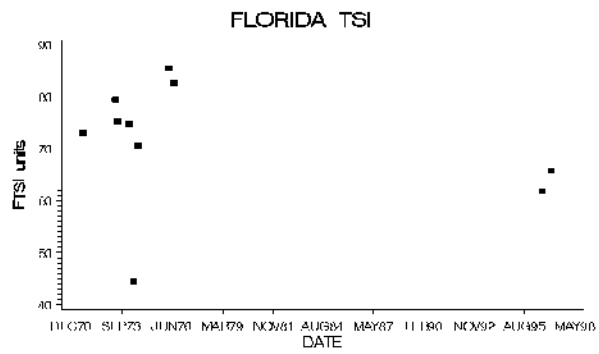

MAJOR IONS (% meq/l)

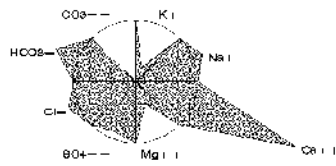

Lake McLeod

Polk County

USGS Quadrangle: Bartow Major Land Use/Land Cover (1990)
 Section/Township/Range: 7-29S-26E within 500 meters of the lakeshore:
 Approx. Lake Center, Lat/Long: 275801/814511 - tree crops, typically citrus (55%)
 Surface Area: 512 acres - medium density residential (19%)
 Approx. Lake Elevation: 132 feet - freshwater marshes (8%)
 Lake Type: outflow (type 2)
 Major Basin: Peace River
 Minor Basin: Lake McLeod Outlet
 Lake Region: Winter Haven/Lake Henry Ridges

Total Number of Samples Collected: 2 Most Recent Sample Collected: January 1996

Parameter	Units (Detection Limit)	Average Value	District Percentile	Florida Percentile
Chlorophyll a	ug/l (1)	10.2	65	38
Total Phosphorus	mg/l as P (0.01)	0.016	56	8
Total Nitrogen	mg/l as N (0.06)	0.81	27	26
Transparency (Secchi depth)	meters	1.50	49	76
Florida Trophic State Index		48	70	30
Specific Conductance	S/cm at 25C (1)	267	83	63
pH	standard units (0.1)	7.8	74	63
Color	PtCo units (1)	13	41	12
Turbidity	NTU (1)	2.0	51	20
Total Alkalinity	mg/l as CaCO3 (1)	42	74	57
Hardness	mg/l as CaCO3 (0.02)	92	88	
Total Suspended Solids	mg/l (0.05)	1.4	37	
Ammonia	mg/l as N (0.03)	0.052	76	
Nitrate+Nitrite	mg/l as N (0.01)	0.005	33	
Total Kjeldahl Nitrogen	mg/l as N (0.06)	0.80	32	
Orthophosphorus	mg/l as P (0.01)	0.008	56	
Chloride	mg/l (0.05)	23	69	
Sulfate	mg/l (0.05)	39	87	
Sodium	mg/l (0.06)	10.4	60	
Potassium	mg/l (0.07)	11.5	92	
Calcium	mg/l (0.04)	18.5	71	
Magnesium	mg/l (0.006)	11.0	90	
Iron	ug/l (0.03)	21	22	

Based upon the average FTSI of 48, water quality is considered good. Lake McLeod can be characterized as a clear to moderately colored (10<color<20 color units), medium hard water, eutrophic lake. The chemical type of water (predominant ionic composition) is calcium sulfate.

Also of note:

- Cattails dominate more than 30% of the lake shoreline.

Plots and Trends: From a low lake surface elevation of under 116 feet in June 1976, lake levels in Lake McLeod have increased throughout the 1980s and up to the present. Recent measurements have remained above 130 feet. Also shown is a diagram of the relative ionic composition of the lake water.

MONTHLY AVERAGE SURFACE ELEVATION

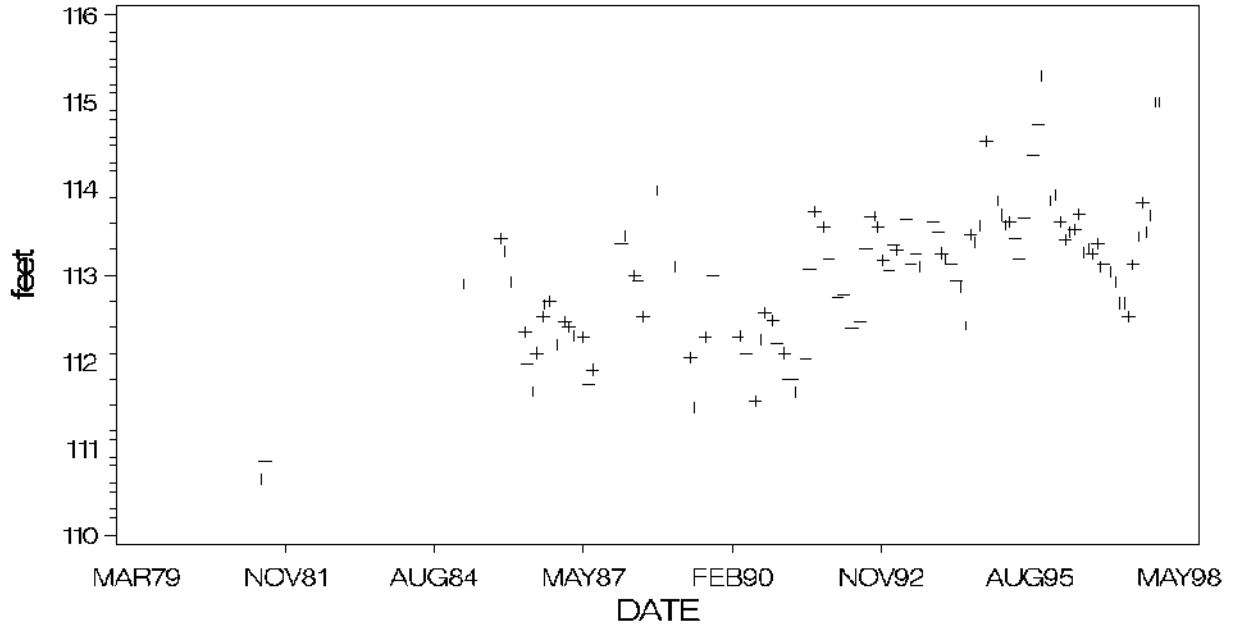

MAJOR IONS (% meq/l)

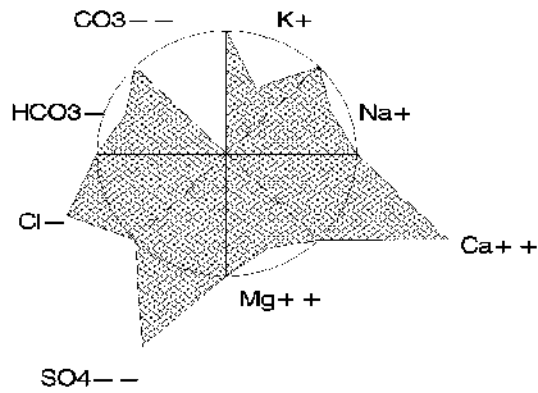

Lake Moody

Polk County

USGS Quadrangle: Babson Park Major Land Use/Land Cover (1990)
 Section/Township/Range: 17-31S-28E within 500 meters of the lakeshore:
 Approx. Lake Center, Lat/Long: 274650/813153 - tree crops, typically citrus (80%)
 Surface Area: 391 acres - stream and lake swamps (11%)
 Approx. Lake Elevation: 94 feet - freshwater marshes (7%)
 Observed Maximum Depth: 13 feet
 (reference elevation not given)
 Lake Type: outflow (type 2)
 Major Basin: Kissimmee Ridge
 Minor Basin: Lake Weohyakapka
 Lake Region: Northern Lake Wales Ridge
 Public Access: yes

Total Number of Samples Collected: 2 Most Recent Sample Collected: January 1997

Parameter	Units (Detection Limit)	Average Value	District Percentile	Florida Percentile
Chlorophyll a	ug/l (1)	32.6	87	68
Total Phosphorus	mg/l as P (0.01)	0.010	33	5
Total Nitrogen	mg/l as N (0.06)	2.28	89	85
Transparency (Secchi depth)	meters	0.48	7	17
Florida Trophic State Index		59	83	53
Specific Conductance	S/cm at 25C (1)	428	>95	78
pH	standard units (0.1)	8.7	93	88
Color	PtCo units (1)	10	34	10
Turbidity	NTU (1)	13.4	93	74
Total Alkalinity	mg/l as CaCO3 (1)	71	92	73
Hardness	mg/l as CaCO3 (0.02)	168	>95	
Total Suspended Solids	mg/l (0.05)	10.7	91	
Ammonia	mg/l as N (0.03)	0.027	60	
Nitrate+Nitrite	mg/l as N (0.01)	0.335	89	
Total Kjeldahl Nitrogen	mg/l as N (0.06)	1.94	88	
Orthophosphorus	mg/l as P (0.01)	0.005	56	
Chloride	mg/l (0.05)	33	89	
Sulfate	mg/l (0.05)	83	>95	
Sodium	mg/l (0.06)	12.4	72	
Potassium	mg/l (0.07)	14.7	>95	
Calcium	mg/l (0.04)	34.4	95	
Magnesium	mg/l (0.006)	20.0	>95	
Iron	ug/l (0.03)	21	23	

Based upon the average FTSI of 59, water quality is considered fair. Lake Moody can be characterized as a clear (color<=10 color units), hard water, eutrophic lake, with high concentrations of total nitrogen. The chemical type of water (predominant ionic composition) is calcium sulfate.

Also of note:

- The measured pH was high.

Plots and Trends: The period of record for lake elevation is relatively short; however, lake levels have risen from the lows recorded in the mid-1980s. Also shown is a diagram of the relative ionic composition of the lake water.

MONTHLY AVERAGE SURFACE ELEVATION

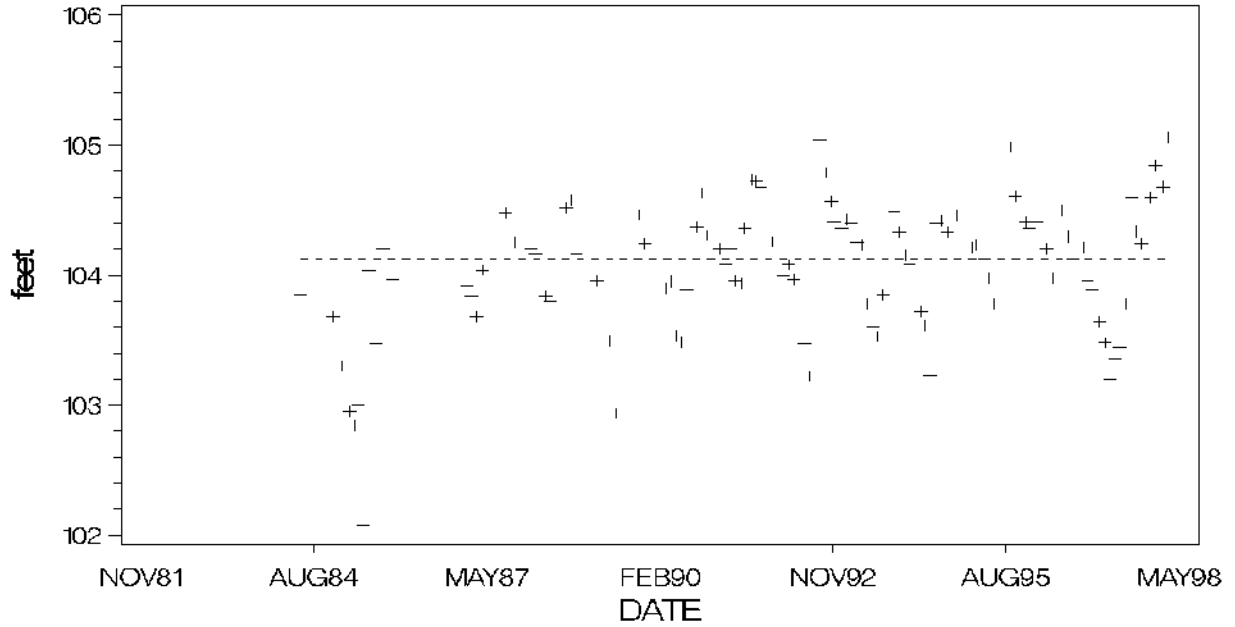

MAJOR IONS (% meq/l)

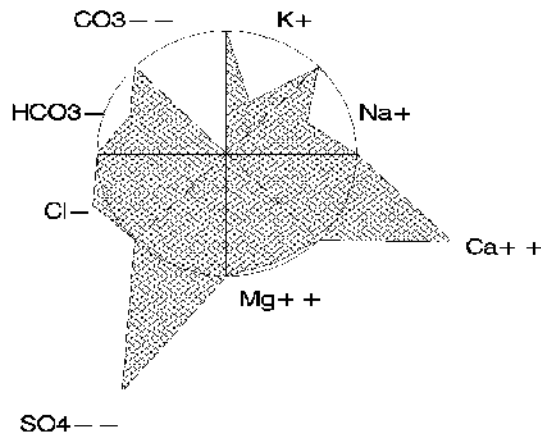

Mud Lake

Polk County

USGS Quadrangle: Polk City Major Land Use/Land Cover (1990)
 Section/Township/Range: 6-27S-25E within 500 meters of the lakeshore:
 Approx. Lake Center, Lat/Long: 281009/815037 - cropland and pastureland (23%)
 Surface Area: 133 acres - other open lands - rural (22%)
 Approx. Lake Elevation: 142 feet - low density residential (17%)
 Observed Maximum Depth: 6.9 feet
 (reference elevation not given)
 Lake Type: isolated (type 4)
 Major Basin: Withlacoochee River
 Minor Basin: Mud Lake Outlet
 Lake Region: Southwestern Flatlands
 Public Access: yes

Total Number of Samples Collected: 2 Most Recent Sample Collected: January 1997

Parameter	Units (Detection Limit)	Average Value	District Percentile	Florida Percentile
Chlorophyll a	ug/l (1)	34.7	88	70
Total Phosphorus	mg/l as P (0.01)	0.032	79	22
Total Nitrogen	mg/l as N (0.06)	1.57	71	64
Transparency (Secchi depth)	meters	0.76	22	46
Florida Trophic State Index		61	85	57
Specific Conductance	S/cm at 25C (1)	134	27	37
pH	standard units (0.1)	8.8	95	90
Color	PtCo units (1)	15	46	13
Turbidity	NTU (1)	5.7	76	54
Total Alkalinity	mg/l as CaCO3 (1)	12	31	29
Hardness	mg/l as CaCO3 (0.02)	42	39	
Total Suspended Solids	mg/l (0.05)	4.9	78	
Ammonia	mg/l as N (0.03)	0.015	60	
Nitrate+Nitrite	mg/l as N (0.01)	0.005	33	
Total Kjeldahl Nitrogen	mg/l as N (0.06)	1.57	79	
Orthophosphorus	mg/l as P (0.01)	0.008	56	
Chloride	mg/l (0.05)	20	56	
Sulfate	mg/l (0.05)	4	17	
Sodium	mg/l (0.06)	6.9	32	
Potassium	mg/l (0.07)	4.5	60	
Calcium	mg/l (0.04)	7.0	24	
Magnesium	mg/l (0.006)	6.0	75	
Iron	ug/l (0.03)	52	62	

Based upon the average FTSI of 61, water quality is considered fair. Mud Lake can be characterized as a clear to moderately colored (10<color<20 color units), soft water, eutrophic to hypereutrophic lake. The chemical type of water (predominant ionic composition) is calcium chloride.

Also of note:

- The measured pH was high
- Waterhyacinth was observed in the lake.

Plots and Trends: The period of record for lake surface elevation is short, and there are no conclusive trends. Also shown is a diagram of the relative ionic composition of the lake water.

MONTHLY AVERAGE SURFACE ELEVATION

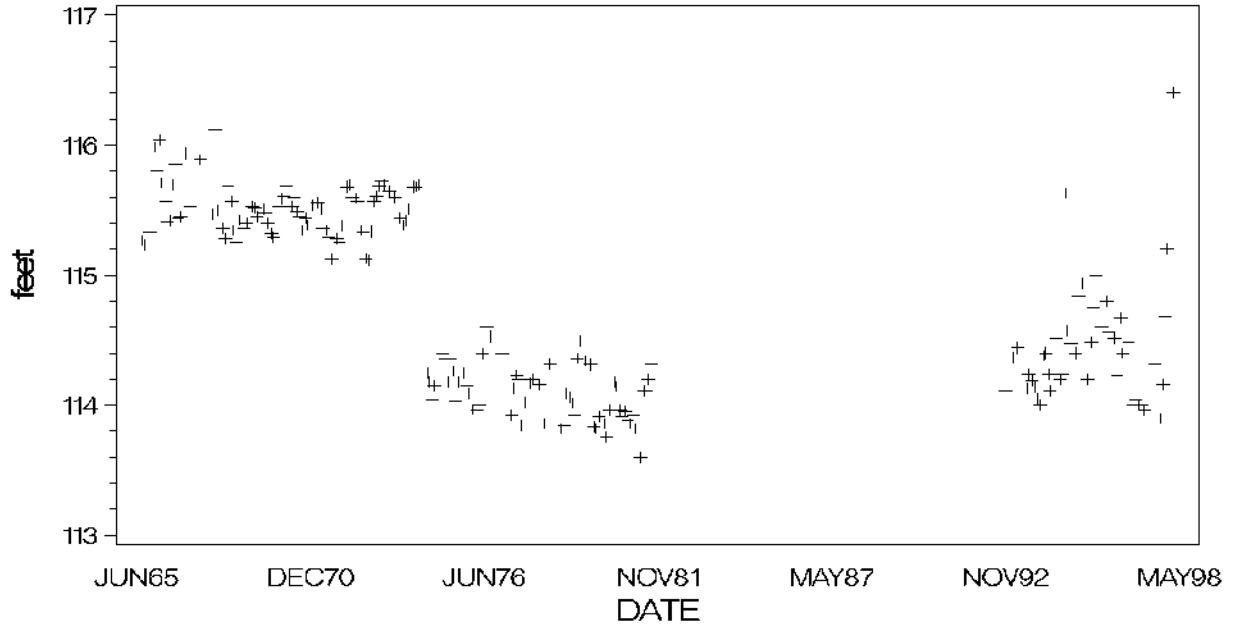

MAJOR IONS (% meq/l)

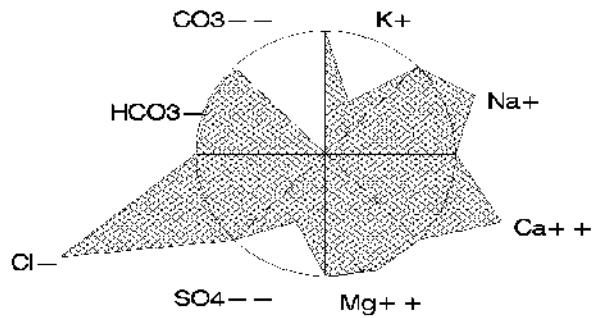

Lake Myrtle

Polk County

USGS Quadrangle: Eloise Major Land Use/Land Cover (1990)
 Section/Township/Range: 19-29S-27E within 500 meters of the lakeshore:
 Approx. Lake Center, Lat/Long: 275650/813904 - cropland and pastureland (64%)
 Surface Area: 413 acres - wet prairies (10%)
 Approx. Lake Elevation: 119 feet - upland coniferous forests (8%)
 Average Depth: 5.7 feet
 Observed Maximum Depth: 8 feet
 (reference elevation 114.1 feet)
 Lake Type: inflow and outflow (type 3)
 Major Basin: Peace River
 Minor Basin: Lake Myrtle Outlet
 Lake Region: Southwestern Flatlands

Total Number of Samples Collected: 2 Most Recent Sample Collected: January 1996

Parameter	Units (Detection Limit)	Average Value	District Percentile	Florida Percentile
Chlorophyll a	ug/l (1)	9.8	63	37
Total Phosphorus	mg/l as P (0.01)	0.018	61	9
Total Nitrogen	mg/l as N (0.06)	1.39	65	50
Transparency (Secchi depth)	meters	0.70	18	40
Florida Trophic State Index		52	76	38
Specific Conductance	S/cm at 25C (1)	218	66	55
pH	standard units (0.1)	7.1	38	35
Color	PtCo units (1)	98	89	76
Turbidity	NTU (1)	4.1	70	43
Total Alkalinity	mg/l as CaCO3 (1)	9	24	24
Hardness	mg/l as CaCO3 (0.02)	56	58	
Total Suspended Solids	mg/l (0.05)	3.1	64	
Ammonia	mg/l as N (0.03)	0.041	69	
Nitrate+Nitrite	mg/l as N (0.01)	0.005	33	
Total Kjeldahl Nitrogen	mg/l as N (0.06)	1.39	74	
Orthophosphorus	mg/l as P (0.01)	0.013	72	
Chloride	mg/l (0.05)	31	87	
Sulfate	mg/l (0.05)	32	81	
Sodium	mg/l (0.06)	15.5	85	
Potassium	mg/l (0.07)	7.8	86	
Calcium	mg/l (0.04)	7.8	27	
Magnesium	mg/l (0.006)	8.8	85	
Iron	ug/l (0.03)	128	87	

Based upon the average FTSI of 52, water quality is considered good. Lake Myrtle can be characterized as a highly colored, soft water, meso-eutrophic lake. The chemical type of water (predominant ionic composition) is sodium chloride.

Plots and Trends: No or insufficient data available for plotting or trend detection. Shown is a diagram of the relative ionic composition of the lake water.

MAJOR IONS (% meq/l)

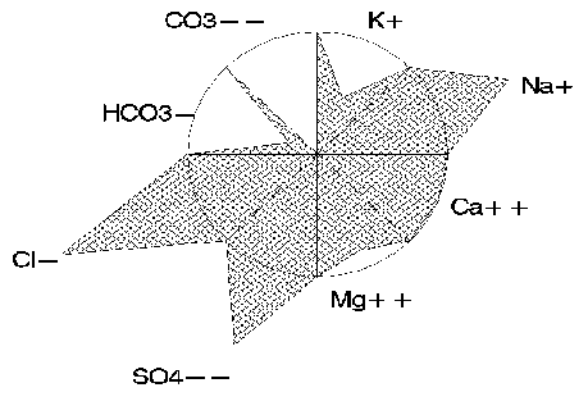

Pabor Lake

Polk County

USGS Quadrangle: Frostproof Major Land Use/Land Cover (1990)
 Section/Township/Range: 33-32S-28E within 500 meters of the lakeshore:
 Approx. Lake Center, Lat/Long: 273850/813108 - tree crops, typically citrus (81%)
 Surface Area: 40 acres - low density residential (7%)
 Approx. Lake Elevation: 103 feet - industrial (6%)
 Lake Type: isolated (type 4)
 Major Basin: Kissimmee Ridge
 Minor Basin: Livingston Creek
 Lake Region: Southern Lake Wales Ridge

Total Number of Samples Collected: 2 Most Recent Sample Collected: January 1995

Parameter	Units (Detection Limit)	Average Value	District Percentile	Florida Percentile
Chlorophyll a	ug/l (1)	5.6	46	23
Total Phosphorus	mg/l as P (0.01)	0.005	31	<5
Total Nitrogen	mg/l as N (0.06)	1.24	57	42
Transparency (Secchi depth)	meters	1.60	52	78
Florida Trophic State Index		34	38	9
Specific Conductance	S/cm at 25C (1)	304	89	70
pH	standard units (0.1)	7.9	78	67
Color	PtCo units (1)	8	24	8
Turbidity	NTU (1)	4.0	70	42
Total Alkalinity	mg/l as CaCO3 (1)	68	91	72
Hardness	mg/l as CaCO3 (0.02)	103	91	
Total Suspended Solids	mg/l (0.05)	3.3	66	
Ammonia	mg/l as N (0.03)	0.245	>95	
Nitrate+Nitrite	mg/l as N (0.01)	0.146	84	
Total Kjeldahl Nitrogen	mg/l as N (0.06)	1.09	54	
Orthophosphorus	mg/l as P (0.01)	0.005	56	
Chloride	mg/l (0.05)	10	15	
Sulfate	mg/l (0.05)	21	63	
Sodium	mg/l (0.06)	10.5	62	
Potassium	mg/l (0.07)	15.5	>95	
Calcium	mg/l (0.04)	20.5	77	
Magnesium	mg/l (0.006)	12.5	92	
Iron	ug/l (0.03)	52	62	

Based upon the average FTSI of 34, water quality is considered good. Pabor Lake can be characterized as a clear (color<=10 color units), medium hard water, mesotrophic lake, with low concentrations of total phosphorus. The chemical type of water (predominant ionic composition) is calcium bicarbonate (1 sample) or calcium sulfate.

Plots and Trends: No or insufficient data available for plotting or trend detection. Shown is a diagram of the relative ionic composition of the lake water.

MAJOR IONS (% meq/l)

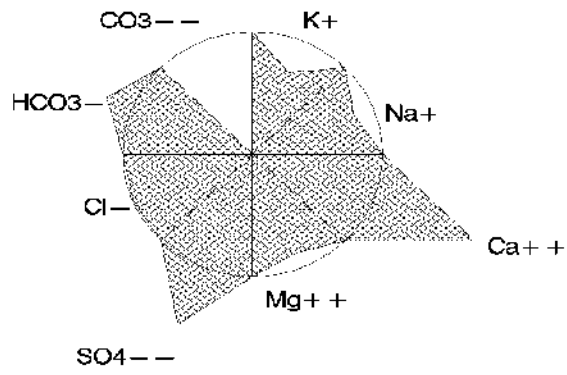

Lake Pansy

Polk County

USGS Quadrangle: Winter Haven Major Land Use/Land Cover (1990)
 Section/Township/Range: 8-28S-26E within 500 meters of the lakeshore:
 Approx. Lake Center, Lat/Long: 280404/814433 - stream and lake swamps (28%)
 Surface Area: 50 acres - transportation (19%)
 Approx. Lake Elevation: 129 feet - tree crops, typically citrus (12%)
 Average Depth: 7.9 feet
 (reference elevation 128 feet)
 Lake Type: outflow (type 2)
 Major Basin: Peace River
 Minor Basin: Lake Fannie Outlet
 Lake Region: Winter Haven/Lake Henry Ridges
 Public Access: yes

Total Number of Samples Collected: 2 Most Recent Sample Collected: February 1997

Parameter	Units (Detection Limit)	Average Value	District Percentile	Florida Percentile
Chlorophyll a	ug/l (1)	14.0	73	44
Total Phosphorus	mg/l as P (0.01)	0.013	46	7
Total Nitrogen	mg/l as N (0.06)	0.64	14	17
Transparency (Secchi depth)	meters	1.06	37	65
Florida Trophic State Index		47	68	29
Specific Conductance	S/cm at 25C (1)	114	17	29
pH	standard units (0.1)	7.3	50	45
Color	PtCo units (1)	60	82	50
Turbidity	NTU (1)	3.2	64	34
Total Alkalinity	mg/l as CaCO3 (1)	14	33	32
Hardness	mg/l as CaCO3 (0.02)	32	25	
Total Suspended Solids	mg/l (0.05)	2.9	64	
Ammonia	mg/l as N (0.03)	0.015	60	
Nitrate+Nitrite	mg/l as N (0.01)	0.005	33	
Total Kjeldahl Nitrogen	mg/l as N (0.06)	0.63	18	
Orthophosphorus	mg/l as P (0.01)	0.010	59	
Chloride	mg/l (0.05)	11	19	
Sulfate	mg/l (0.05)	17	54	
Sodium	mg/l (0.06)	8.9	51	
Potassium	mg/l (0.07)	2.6	42	
Calcium	mg/l (0.04)	7.0	24	
Magnesium	mg/l (0.006)	3.5	52	
Iron	ug/l (0.03)	50	60	

Based upon the average FTSI of 47, water quality is considered good. Lake Pansy can be characterized as a colored, soft water, meso-eutrophic lake, with low concentrations of total nitrogen. The chemical type of water (predominant ionic composition) is calcium sulfate (1 sample) or sodium sulfate (1 sample).

Plots and Trends: Also shown is a diagram of the relative ionic composition of the lake water.

MONTHLY AVERAGE SURFACE ELEVATION

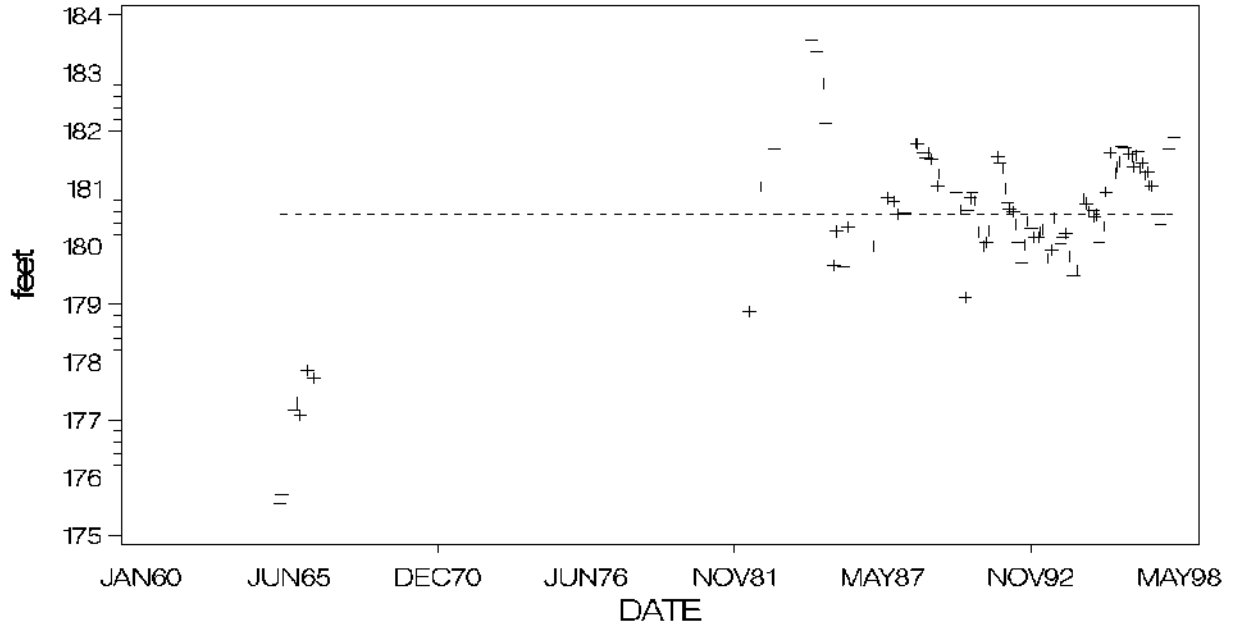

MAJOR IONS (% meq/l)

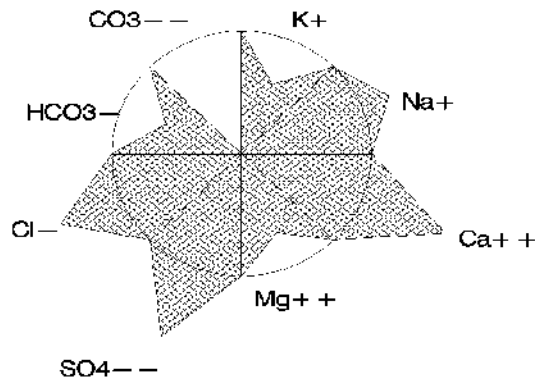

Lake Pansy, Polk County

Lake Parker

Polk County

USGS Quadrangle: Eloise
 Section/Township/Range: 32-29S-27E
 Approx. Lake Center, Lat/Long: 275449/813814
 Surface Area: 123 acres
 Approx. Lake Elevation: 123 feet
 Observed Maximum Depth: 15.1 feet
 (reference elevation not given)
 Lake Type: isolated (type 4)
 Major Basin: Peace River
 Minor Basin: Peace Cr Trib Canal
 Lake Region: Lake Wales Ridge Transition

Major Land Use/Land Cover (1990)
 within 500 meters of the lakeshore:
 - tree crops, typically citrus (48%)
 - cropland and pastureland (31%)
 - medium density residential (8%)

Total Number of Samples Collected: 2 Most Recent Sample Collected: January 1996

Parameter	Units (Detection Limit)	Average Value	District Percentile	Florida Percentile
Chlorophyll a	ug/l (1)	4.2	39	17
Total Phosphorus	mg/l as P (0.01)	0.015	53	8
Total Nitrogen	mg/l as N (0.06)	1.80	79	75
Transparency (Secchi depth)	meters	2.10	67	87
Florida Trophic State Index		37	46	12
Specific Conductance	S/cm at 25C (1)	307	89	70
pH	standard units (0.1)	7.1	38	35
Color	PtCo units (1)	13	41	12
Turbidity	NTU (1)	1.0	29	5
Total Alkalinity	mg/l as CaCO3 (1)	7	18	20
Hardness	mg/l as CaCO3 (0.02)	92	88	
Total Suspended Solids	mg/l (0.05)	0.8	21	
Ammonia	mg/l as N (0.03)	0.131	91	
Nitrate+Nitrite	mg/l as N (0.01)	0.191	86	
Total Kjeldahl Nitrogen	mg/l as N (0.06)	1.60	80	
Orthophosphorus	mg/l as P (0.01)	0.011	64	
Chloride	mg/l (0.05)	26	78	
Sulfate	mg/l (0.05)	80	>95	
Sodium	mg/l (0.06)	13.0	76	
Potassium	mg/l (0.07)	14.5	>95	
Calcium	mg/l (0.04)	10.5	41	
Magnesium	mg/l (0.006)	16.0	>95	
Iron	ug/l (0.03)	39	52	

Based upon the average FTSI of 37, water quality is considered good. Lake Parker can be characterized as a clear to moderately colored (10<color<20 color units), medium hard water, mesotrophic lake. The chemical type of water (predominant ionic composition) is magnesium sulfate.

Plots and Trends: Shown are a plot of lake surface elevation and a diagram of the relative ionic composition of the lake water.

MONTHLY AVERAGE SURFACE ELEVATION

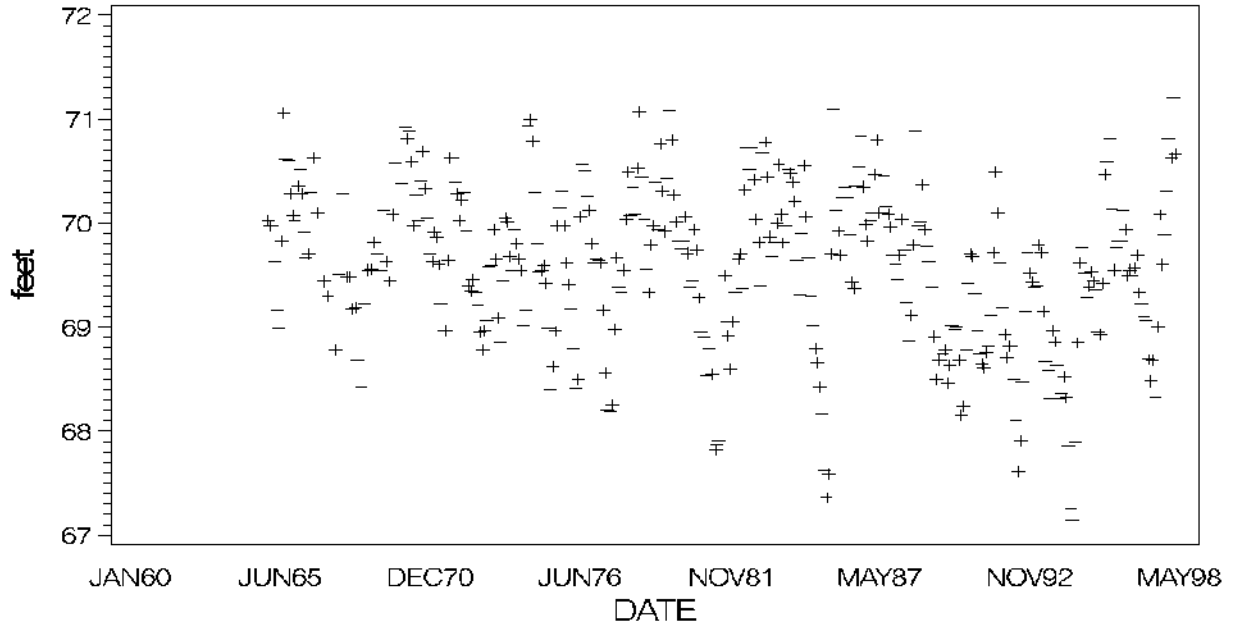

MAJOR IONS (% meq/l)

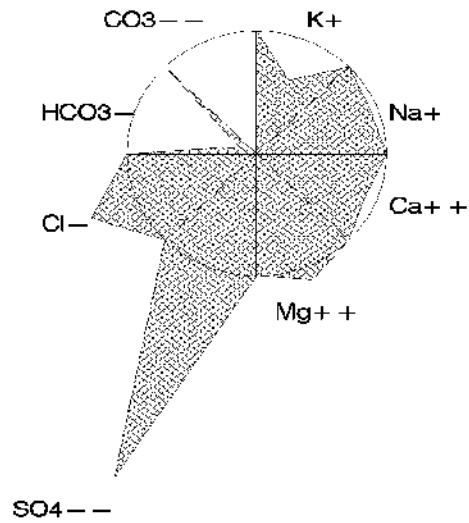

Reedy Lake Polk County

USGS Quadrangle: Lake Arbuckle Major Land Use/Land Cover (1990)
 Section/Township/Range: 35-31S-28E within 500 meters of the lakeshore:
 Approx. Lake Center, Lat/Long: 274414/813000 - tree crops, typically citrus (45%)
 Surface Area: 3486 acres - medium density residential (21%)
 Approx. Lake Elevation: 80 feet - pine flatwoods (9%)
 Average Depth: 9.9 feet
 Observed Maximum Depth: 14 feet
 (reference elevation not given)
 Lake Type: inflow and outflow (type 3)
 Major Basin: Kissimmee Ridge
 Minor Basin: Reedy Creek
 Lake Region: Northern Lake Wales Ridge
 Public Access: yes

Total Number of Samples Collected: 2 Most Recent Sample Collected: January 1997

Parameter	Units (Detection Limit)	Average Value	District Percentile	Florida Percentile
Chlorophyll a	ug/l (1)	10.8	67	40
Total Phosphorus	mg/l as P (0.01)	0.008	31	<5
Total Nitrogen	mg/l as N (0.06)	1.05	45	35
Transparency (Secchi depth)	meters	1.14	39	68
Florida Trophic State Index		44	60	21
Specific Conductance	S/cm at 25C (1)	235	74	58
pH	standard units (0.1)	8.5	91	83
Color	PtCo units (1)	13	41	12
Turbidity	NTU (1)	4.9	74	49
Total Alkalinity	mg/l as CaCO3 (1)	34	64	52
Hardness	mg/l as CaCO3 (0.02)	61	63	
Total Suspended Solids	mg/l (0.05)	6.7	85	
Ammonia	mg/l as N (0.03)	0.015	60	
Nitrate+Nitrite	mg/l as N (0.01)	0.127	83	
Total Kjeldahl Nitrogen	mg/l as N (0.06)	0.93	41	
Orthophosphorus	mg/l as P (0.01)	0.005	56	
Chloride	mg/l (0.05)	19	51	
Sulfate	mg/l (0.05)	42	89	
Sodium	mg/l (0.06)	9.8	57	
Potassium	mg/l (0.07)	7.0	81	
Calcium	mg/l (0.04)	16.5	64	
Magnesium	mg/l (0.006)	4.8	66	
Iron	ug/l (0.03)	28	35	

Based upon the average FTSI of 44, water quality is considered good. Reedy Lake can be characterized as a clear to moderately colored (10<color<20 color units), hard water, meso-eutrophic lake, with low concentrations of total phosphorus. The chemical type of water (predominant ionic composition) is calcium sulfate (2 samples) or magnesium sulfate (1 sample). Also of note: the measured pH was high.

Plots and Trends: Two samples collected in 1996-1997 had lower concentrations of total phosphorus than for samples collected during the 1970s. Total nitrogen was generally lower in 1996-1997, although within the range of the historical values. As shown by the plot for Florida TSI, water quality ranged from good (TSI<=60) to poor (TSI>70) during the 1970s. Due to this variability, it is difficult to determine if there are any long-term changes in water quality. Lake surface elevation has been stable over the period of record. Also shown is a diagram of the relative ionic composition of the lake water.

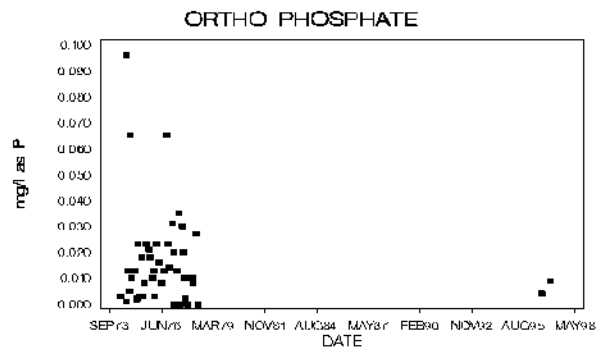
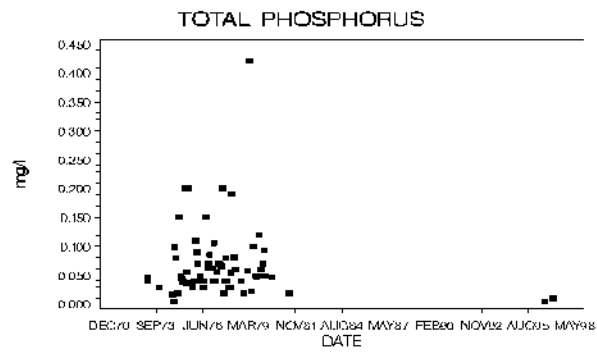
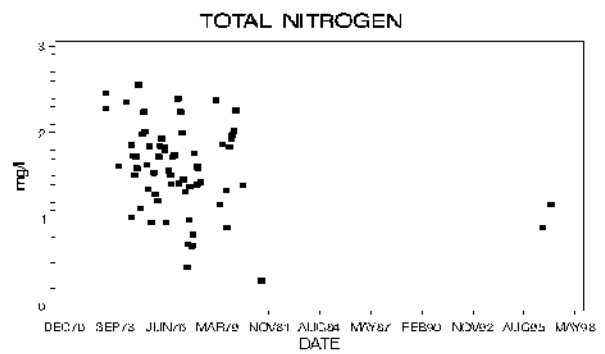
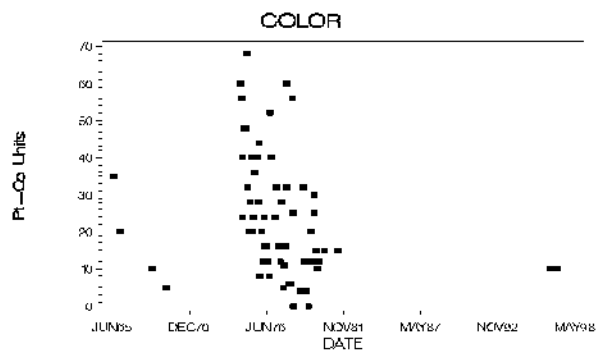
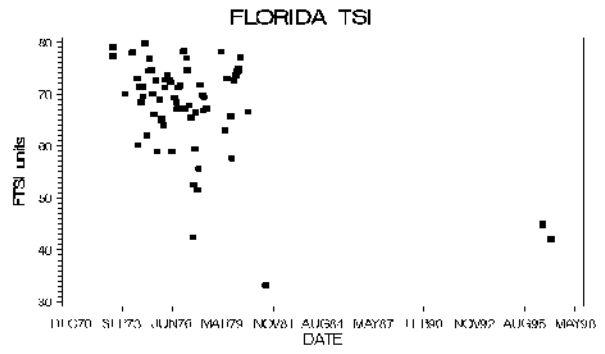
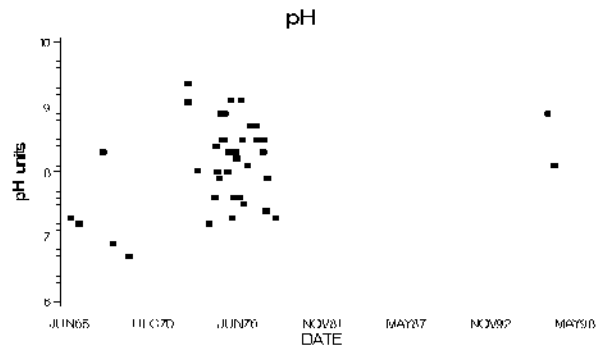
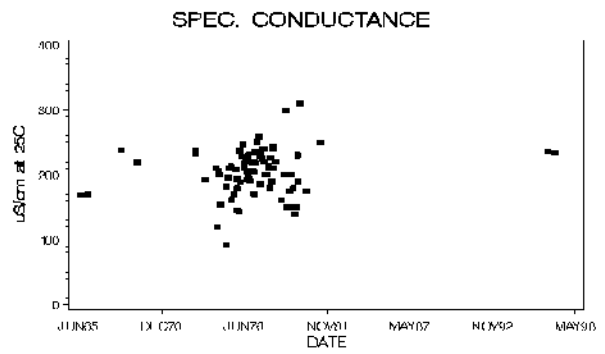
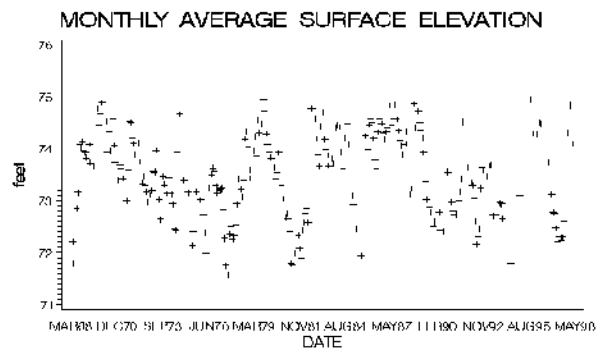

Reedy Lake, Polk County

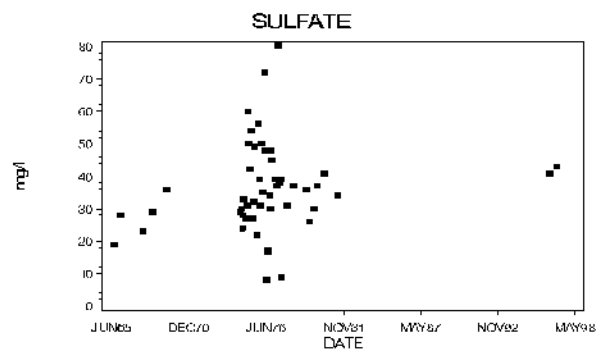
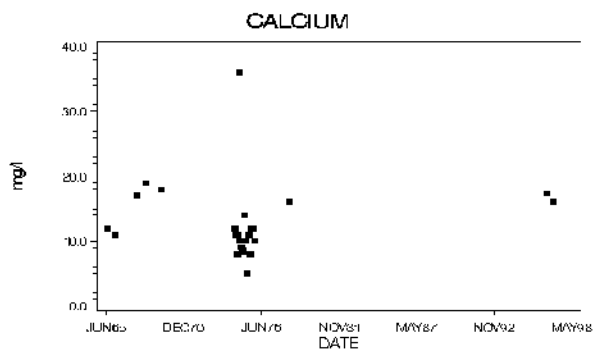
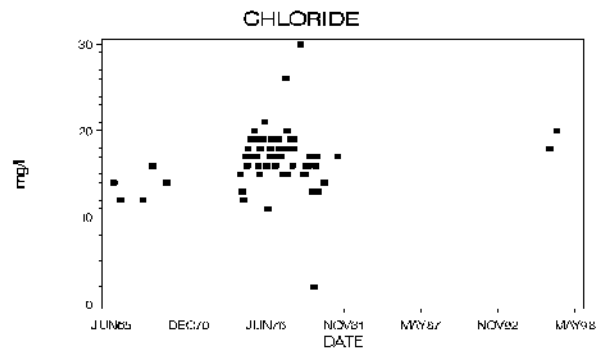
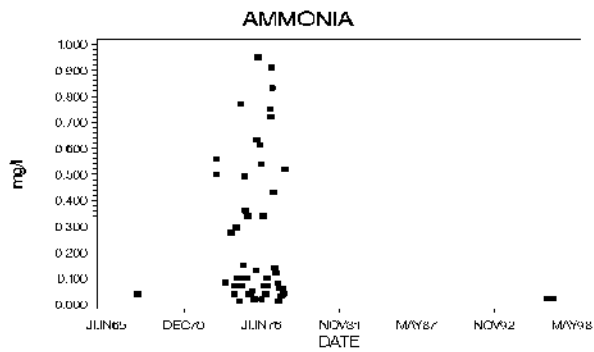
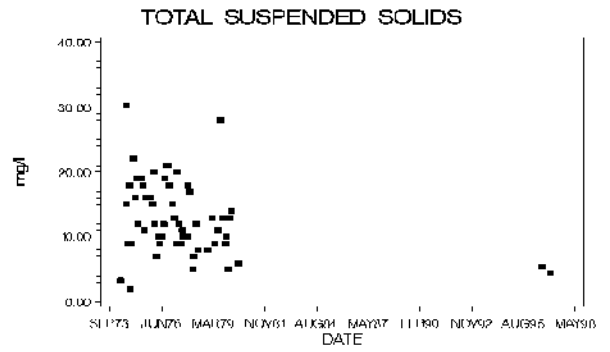
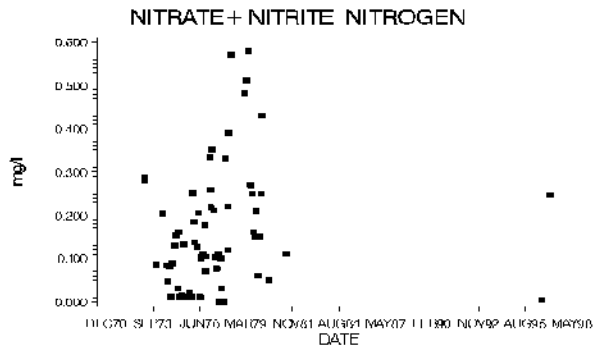
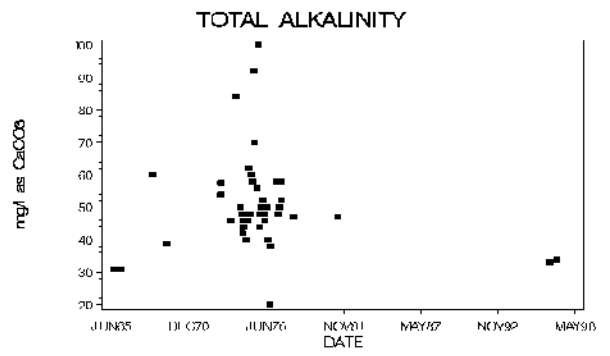
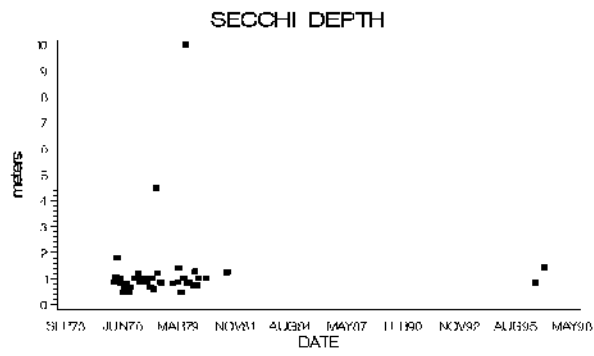

Reedy Lake, Polk County

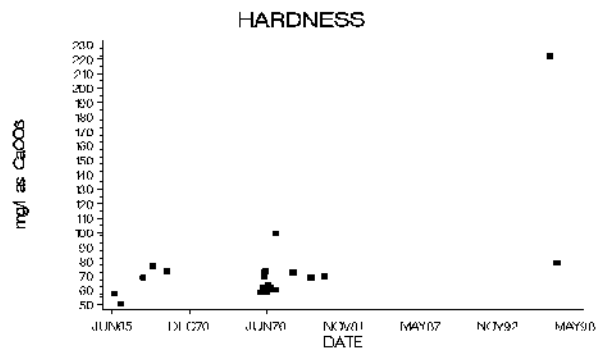

Lake Rochelle

Polk County

USGS Quadrangle: Winter Haven Major Land Use/Land Cover (1990)
 Section/Township/Range: 4-28S-26E within 500 meters of the lakeshore:
 Approx. Lake Center, Lat/Long: 280422/814313 - tree crops, typically citrus (20%)
 Surface Area: 578 acres - stream and lake swamps (20%)
 Approx. Lake Elevation: 129 feet - cropland and pastureland (15%)
 Observed Maximum Depth: 17 feet
 (reference elevation not given)
 Lake Type: inflow and outflow (type 3)
 Major Basin: Peace River
 Minor Basin: Lake Fannie Outlet
 Lake Region: Southwestern Flatlands
 Public Access: yes

Total Number of Samples Collected: 2 Most Recent Sample Collected: February 1997

Parameter	Units (Detection Limit)	Average Value	District Percentile	Florida Percentile
Chlorophyll a	ug/l (1)	37.0	88	72
Total Phosphorus	mg/l as P (0.01)	0.033	79	23
Total Nitrogen	mg/l as N (0.06)	1.04	43	35
Transparency (Secchi depth)	meters	0.67	18	37
Florida Trophic State Index		60	83	54
Specific Conductance	S/cm at 25C (1)	203	60	52
pH	standard units (0.1)	9.1	>95	94
Color	PtCo units (1)	35	70	27
Turbidity	NTU (1)	11.6	91	72
Total Alkalinity	mg/l as CaCO3 (1)	63	89	69
Hardness	mg/l as CaCO3 (0.02)	64	67	
Total Suspended Solids	mg/l (0.05)	4.8	77	
Ammonia	mg/l as N (0.03)	0.015	60	
Nitrate+Nitrite	mg/l as N (0.01)	0.005	33	
Total Kjeldahl Nitrogen	mg/l as N (0.06)	1.04	51	
Orthophosphorus	mg/l as P (0.01)	0.008	56	
Chloride	mg/l (0.05)	23	69	
Sulfate	mg/l (0.05)	9	34	
Sodium	mg/l (0.06)	14.0	80	
Potassium	mg/l (0.07)	7.8	86	
Calcium	mg/l (0.04)	15.5	62	
Magnesium	mg/l (0.006)	6.1	76	
Iron	ug/l (0.03)	33	44	

Based upon the average FTSI of 60, water quality is considered good. Lake Rochelle can be characterized as a moderately colored, medium hard water, eutrophic lake. The chemical type of water (predominant ionic composition) is calcium chloride.

Also of note:

- The measured pH was very high.
- Cattails dominate more than 30% of the lake shoreline.

Plots and Trends: There are few current data for lake surface elevation. Present-day values of Florida TSI, total nitrogen, and total alkalinity are similar to historic values. Also shown is a diagram of the relative ionic composition of the lake water.

MONTHLY AVERAGE SURFACE ELEVATION

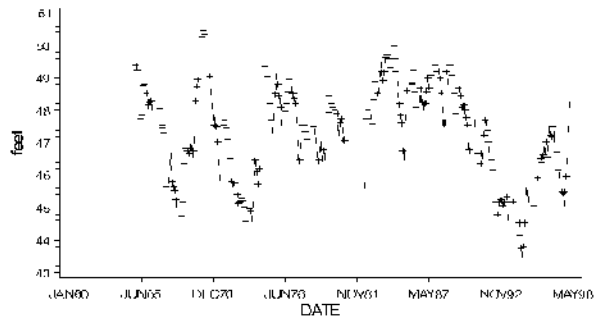

FLORIDA TSI

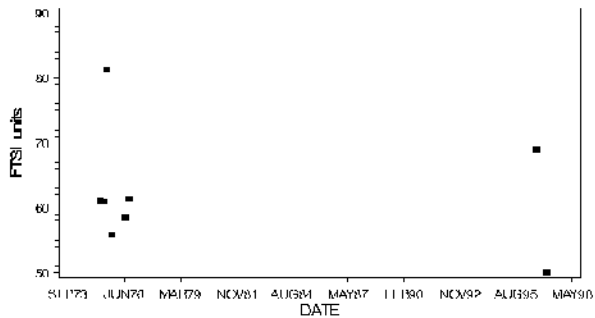

TOTAL NITROGEN

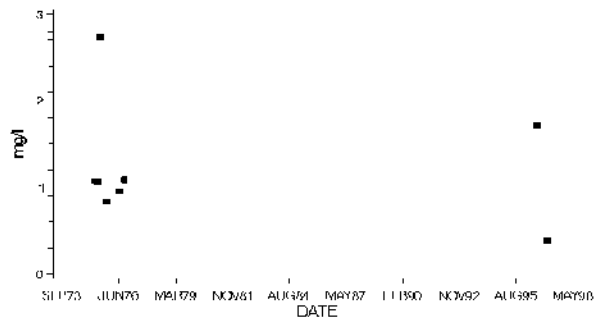

TOTAL ALKALINITY

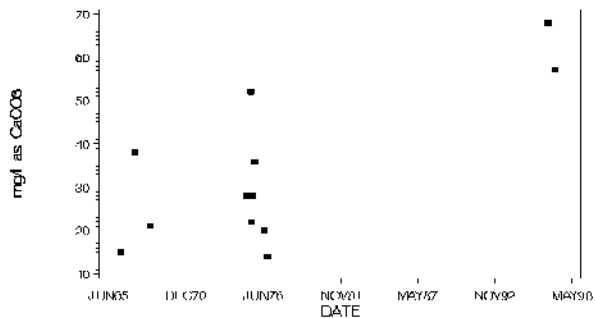

MAJOR IONS (% meq/l)

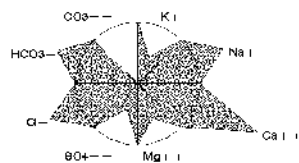

Lake Rochelle, Polk County

Lake Ruby

Polk County

USGS Quadrangle: Eloise
 Section/Township/Range: 12-29S-26E
 Approx. Lake Center, Lat/Long: 275812/813943
 Surface Area: 255 acres
 Approx. Lake Elevation: 125 feet
 Observed Maximum Depth: 15.1 feet
 (reference elevation not given)
 Lake Type: inflow and outflow (type 3)
 Major Basin: Peace River
 Minor Basin: Lake Myrtle Outlet
 Lake Region: Winter Haven/Lake Henry Ridges
 Public Access: yes

Major Land Use/Land Cover (1990)
 within 500 meters of the lakeshore:
 - tree crops, typically citrus (58%)
 - shrub and brushland range (6%)
 - low density residential (6%)

Total Number of Samples Collected: 2 Most Recent Sample Collected: January 1997

Parameter	Units (Detection Limit)	Average Value	District Percentile	Florida Percentile
Chlorophyll a	ug/l (1)	39.7	91	74
Total Phosphorus	mg/l as P (0.01)	0.034	80	24
Total Nitrogen	mg/l as N (0.06)	2.27	89	85
Transparency (Secchi depth)	meters	0.47	6	16
Florida Trophic State Index		66	91	67
Specific Conductance	S/cm at 25C (1)	386	95	75
pH	standard units (0.1)	8.0	81	70
Color	PtCo units (1)	5	9	5
Turbidity	NTU (1)	15.5	94	77
Total Alkalinity	mg/l as CaCO3 (1)	48	78	61
Hardness	mg/l as CaCO3 (0.02)	134	>95	
Total Suspended Solids	mg/l (0.05)	10.2	90	
Ammonia	mg/l as N (0.03)	0.047	73	
Nitrate+Nitrite	mg/l as N (0.01)	0.022	54	
Total Kjeldahl Nitrogen	mg/l as N (0.06)	2.25	94	
Orthophosphorus	mg/l as P (0.01)	0.029	90	
Chloride	mg/l (0.05)	35	92	
Sulfate	mg/l (0.05)	82	>95	
Sodium	mg/l (0.06)	12.0	69	
Potassium	mg/l (0.07)	14.0	>95	
Calcium	mg/l (0.04)	25.5	88	
Magnesium	mg/l (0.006)	17.0	>95	
Iron	ug/l (0.03)	31	40	

Based upon the average FTSI of 66, water quality is considered fair. Lake Ruby can be characterized as a clear (color<=10 color units), hard water, eutrophic to hypereutrophic lake, with high concentrations of total phosphorus and high concentrations of total nitrogen. The chemical type of water (predominant ionic composition) is calcium sulfate.

Also of note:

- The measured pH was high.
- Melaleuca was observed on the lake shore.

Plots and Trends: Shown are plots of lake surface elevation and specific conductance, and a diagram of the relative ionic composition of the lake water. The amplitude and frequency of lake surface elevation fluctuation appear to have changed beginning about 1990. Recent observations of conductance were generally lower than observations made during the 1970s, though they are within the range of the previous measurements.

MONTHLY AVERAGE SURFACE ELEVATION

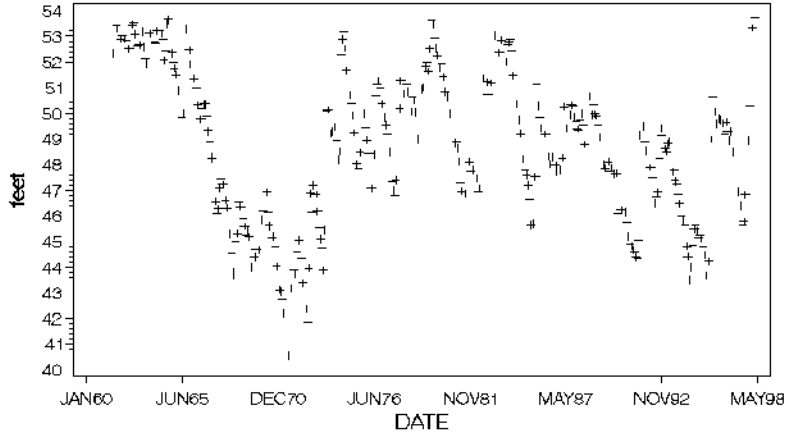

SPEC. CONDUCTANCE

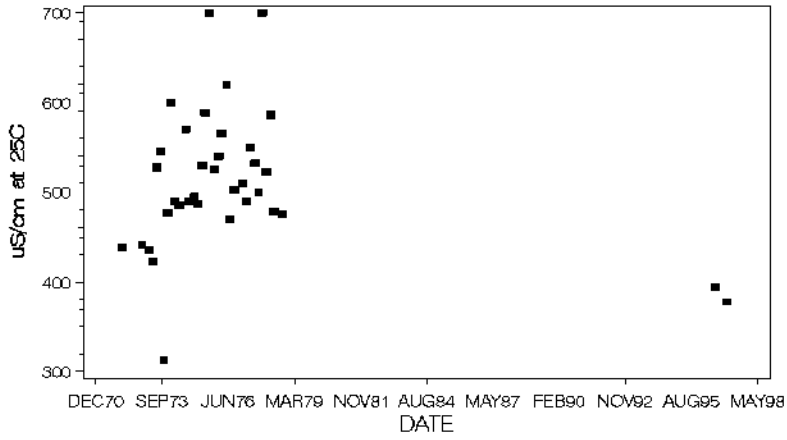

MAJOR IONS (% meq/l)

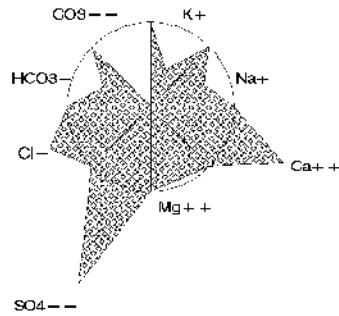

Lake Ruby, Polk County

Scott Lake Polk County

USGS Quadrangle: Mulberry Major Land Use/Land Cover (1990)
 Section/Township/Range: 18-29S-24E within 500 meters of the lakeshore:
 Approx. Lake Center, Lat/Long: 275756/815624 - medium density residential (53%)
 Surface Area: 285 acres - tree crops, typically citrus (13%)
 Approx. Lake Elevation: 168 feet - upland hardwood forests (10%)
 Observed Maximum Depth: 13 feet
 (reference elevation not given)
 Lake Type: inflow and outflow (type 3)
 Major Basin: Alafia River
 Minor Basin: Lake Drain
 Lake Region: Lakeland/Bone Valley Upland

Total Number of Samples Collected: 2 Most Recent Sample Collected: January 1996

Parameter	Units (Detection Limit)	Average Value	District Percentile	Florida Percentile
Chlorophyll a	ug/l (1)	65.9	95	89
Total Phosphorus	mg/l as P (0.01)	0.041	84	36
Total Nitrogen	mg/l as N (0.06)	1.63	73	67
Transparency (Secchi depth)	meters	0.55	13	25
Florida Trophic State Index		75	>95	91
Specific Conductance	S/cm at 25C (1)	208	63	53
pH	standard units (0.1)	9.0	>95	93
Color	PtCo units (1)	8	24	8
Turbidity	NTU (1)	12.2	91	73
Total Alkalinity	mg/l as CaCO3 (1)	41	72	57
Hardness	mg/l as CaCO3 (0.02)	70	72	
Total Suspended Solids	mg/l (0.05)	13.7	95	
Ammonia	mg/l as N (0.03)	0.053	77	
Nitrate+Nitrite	mg/l as N (0.01)	0.008	33	
Total Kjeldahl Nitrogen	mg/l as N (0.06)	1.62	80	
Orthophosphorus	mg/l as P (0.01)	0.027	89	
Chloride	mg/l (0.05)	24	74	
Sulfate	mg/l (0.05)	15	50	
Sodium	mg/l (0.06)	13.0	76	
Potassium	mg/l (0.07)	3.2	48	
Calcium	mg/l (0.04)	17.5	67	
Magnesium	mg/l (0.006)	6.5	79	
Iron	ug/l (0.03)	43	55	

Based upon the average FTSI of 75, water quality is considered poor. Scott Lake can be characterized as a clear (color<=10 color units), medium hard water, hypereutrophic lake, with high concentrations of total phosphorus. The chemical type of water (predominant ionic composition) is calcium chloride.

Also of note:

- The measured pH was very high.

Plots and Trends: Plots of water chemistry show an extreme range in variability for the variables plotted; conductance ranged from near 100 to over 400 uS/cm, pH from 5 to 9 units, and total alkalinity ranged from near zero to 140 mg/l. Also shown is a diagram of the relative ionic composition of the lake water.

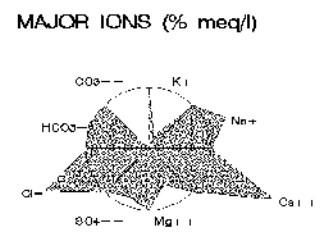
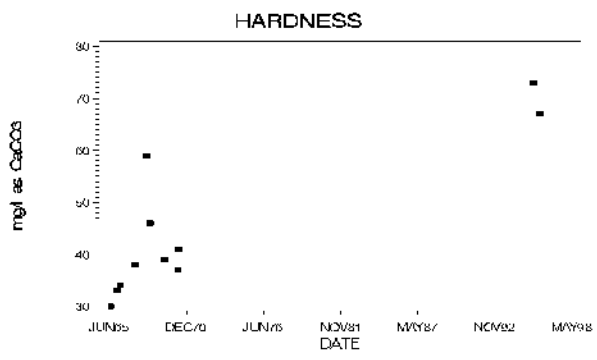
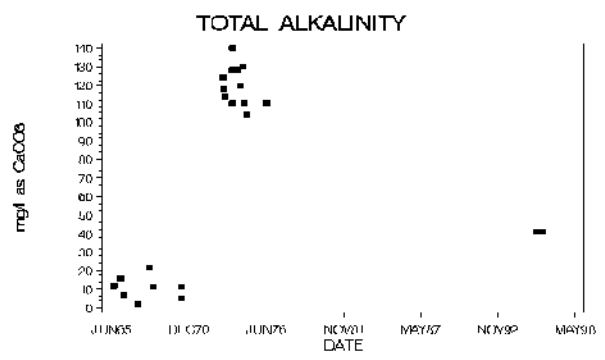
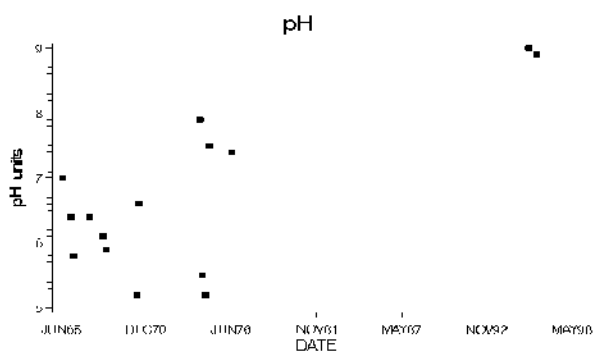
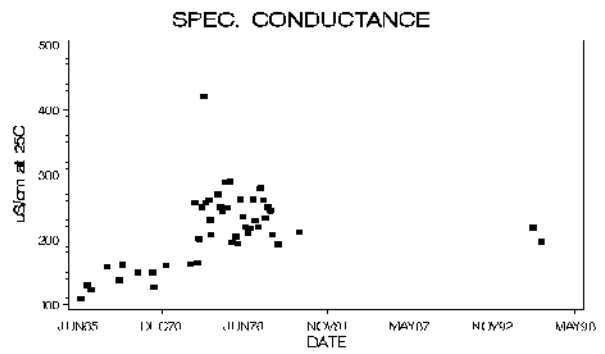
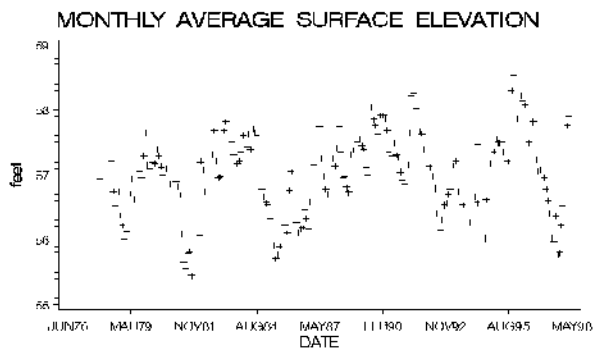

Scott Lake, Polk County

Lake Shipp Polk County

USGS Quadrangle:	Winter Haven	Major Land Use/Land Cover (1990)
Section/Township/Range:	32-28S-26E	within 500 meters of the lakeshore:
Approx. Lake Center, Lat/Long:	280008/814433	- medium density residential (26%)
Surface Area:	283 acres	- high density residential (18%)
Approx. Lake Elevation:	132 feet	- industrial (15%)
Average Depth: 6.9 feet		
Observed Maximum Depth: 10 feet (reference elevation 130 feet)		
Lake Type: inflow and outflow (type 3)		
Major Basin: Peace River		
Minor Basin: Lake Lulu Outlet		
Lake Region: Winter Haven/Lake Henry Ridges		
Public Access: yes		

Total Number of Samples Collected: 2 Most Recent Sample Collected: January 1997

Parameter	Units (Detection Limit)	Average Value	District Percentile	Florida Percentile
Chlorophyll a	ug/l (1)	75.2	>95	91
Total Phosphorus	mg/l as P (0.01)	0.039	83	29
Total Nitrogen	mg/l as N (0.06)	2.55	91	88
Transparency (Secchi depth)	meters	0.47	6	16
Florida Trophic State Index		72	>95	85
Specific Conductance	S/cm at 25C (1)	227	69	56
pH	standard units (0.1)	8.7	93	88
Color	PtCo units (1)	10	34	10
Turbidity	NTU (1)	15.7	94	77
Total Alkalinity	mg/l as CaCO3 (1)	62	87	69
Hardness	mg/l as CaCO3 (0.02)	79	79	
Total Suspended Solids	mg/l (0.05)	20.5	>95	
Ammonia	mg/l as N (0.03)	0.015	60	
Nitrate+Nitrite	mg/l as N (0.01)	0.005	33	
Total Kjeldahl Nitrogen	mg/l as N (0.06)	2.55	>95	
Orthophosphorus	mg/l as P (0.01)	0.037	92	
Chloride	mg/l (0.05)	18	46	
Sulfate	mg/l (0.05)	20	61	
Sodium	mg/l (0.06)	12.0	69	
Potassium	mg/l (0.07)	4.5	60	
Calcium	mg/l (0.04)	24.0	86	
Magnesium	mg/l (0.006)	4.5	63	
Iron	ug/l (0.03)	38	51	

Based upon the average FTSI of 72, water quality is considered poor. Lake Shipp can be characterized as a clear (color<=10 color units), medium hard water, hypereutrophic lake, with high concentrations of total phosphorus and high concentrations of total nitrogen. The chemical type of water (predominant ionic composition) is calcium bicarbonate.

Also of note:

- The measured pH was high.

Plots and Trends: Shown is a plot of chlorophyll a, and a diagram of the relative ionic composition of the lake water.

CHLOROPHYLL a

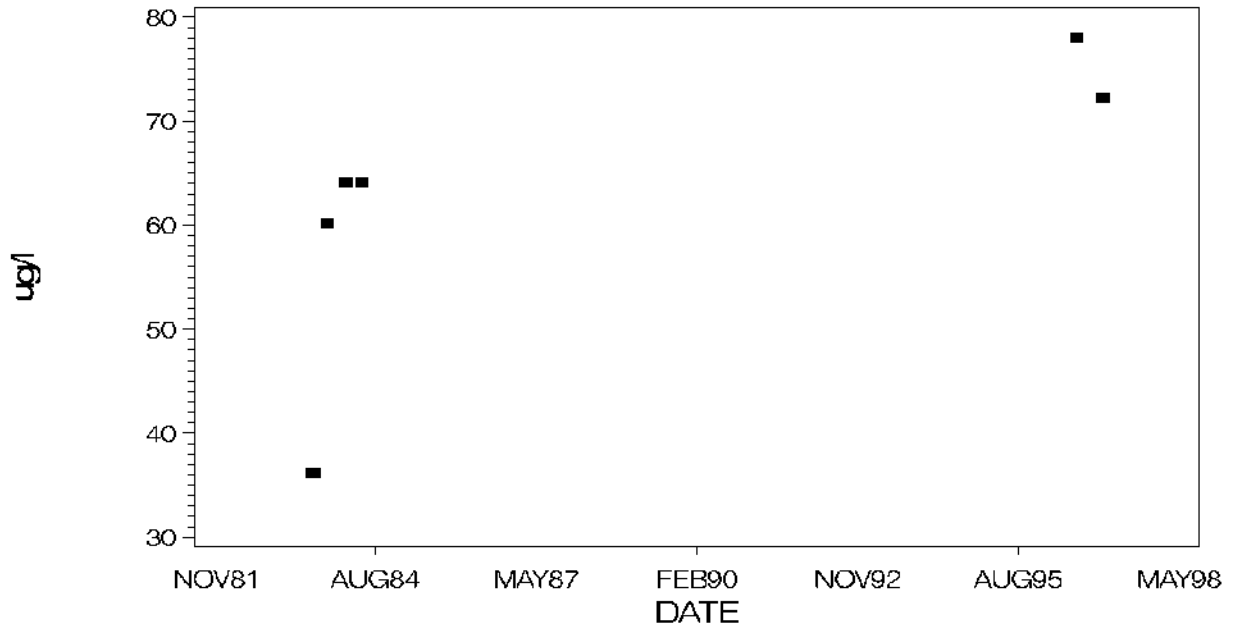

MAJOR IONS (% meq/l)

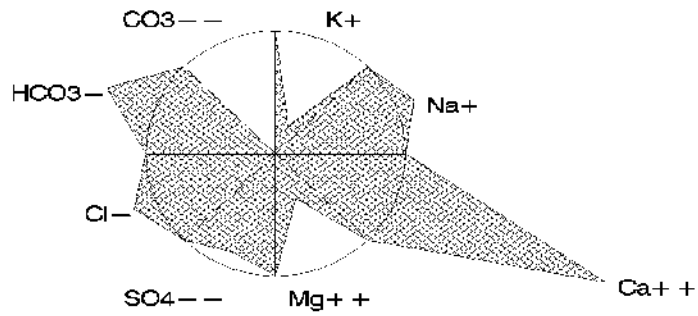

Spirit Lake

Polk County

USGS Quadrangle: Bartow
 Section/Township/Range: 35-28S-25E
 Approx. Lake Center, Lat/Long: 275959/814637
 Surface Area: 224 acres
 Approx. Lake Elevation: 132 feet
 Average Depth: 14.8 feet
 (reference elevation 92.94 feet)
 Lake Type: isolated (type 4)
 Major Basin: Peace River
 Minor Basin: Lake Lena Run
 Lake Region: Winter Haven/Lake Henry Ridges

Major Land Use/Land Cover (1990)
 within 500 meters of the lakeshore:
 - medium density residential (44%)
 - tree crops, typically citrus (37%)
 - low density residential (5%)

Total Number of Samples Collected: 2 Most Recent Sample Collected: January 1996

Parameter	Units (Detection Limit)	Average Value	District Percentile	Florida Percentile
Chlorophyll a	ug/l (1)	9.8	63	37
Total Phosphorus	mg/l as P (0.01)	0.015	53	8
Total Nitrogen	mg/l as N (0.06)	0.61	9	16
Transparency (Secchi depth)	meters		-	-
Florida Trophic State Index		50	72	34
Specific Conductance	S/cm at 25C (1)	287	86	67
pH	standard units (0.1)	7.8	74	63
Color	PtCo units (1)	10	34	10
Turbidity	NTU (1)	2.3	55	24
Total Alkalinity	mg/l as CaCO3 (1)	38	70	55
Hardness	mg/l as CaCO3 (0.02)	91	87	
Total Suspended Solids	mg/l (0.05)	1.6	42	
Ammonia	mg/l as N (0.03)	0.134	92	
Nitrate+Nitrite	mg/l as N (0.01)	0.012	40	
Total Kjeldahl Nitrogen	mg/l as N (0.06)	0.60	15	
Orthophosphorus	mg/l as P (0.01)	0.009	56	
Chloride	mg/l (0.05)	30	85	
Sulfate	mg/l (0.05)	42	89	
Sodium	mg/l (0.06)	14.0	80	
Potassium	mg/l (0.07)	11.5	92	
Calcium	mg/l (0.04)	13.5	54	
Magnesium	mg/l (0.006)	14.0	95	
Iron	ug/l (0.03)	19	18	

Based upon the average FTSI of 50, water quality is considered good. Spirit Lake can be characterized as a clear (color<=10 color units), medium hard water, eutrophic lake, with very low concentrations of total nitrogen. The chemical type of water (predominant ionic composition) is calcium sulfate.

Also of note:

- Hydrilla was observed in the lake.
- Cattails dominate more than 30% of the lake shoreline.

Plots and Trends: No or insufficient data available for plotting or trend detection. Shown is a diagram of the relative ionic composition of the lake water.

MAJOR IONS (% meq/l)

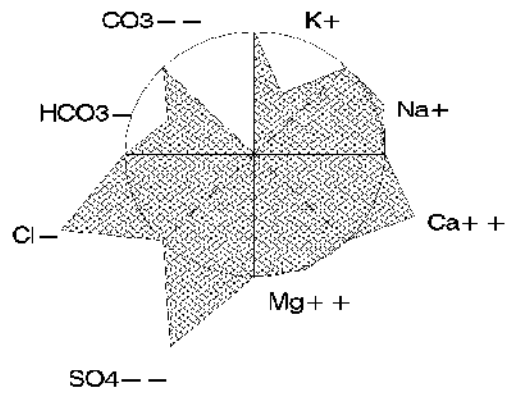

Lake Starr

Polk County

USGS Quadrangle: Lake Wales Major Land Use/Land Cover (1990)
 Section/Township/Range: 14-29S-27E within 500 meters of the lakeshore:
 Approx. Lake Center, Lat/Long: 275725/813514 - tree crops, typically citrus (50%)
 Surface Area: 147 acres - low density residential (42%)
 Approx. Lake Elevation: 113 feet - other open lands - rural (5%)
 Observed Maximum Depth: 27 feet
 (reference elevation not given)
 Lake Type: isolated (type 4)
 Major Basin: Peace River
 Minor Basin: Peace Creek Dr Canal
 Lake Region: Northern Lake Wales Ridge

Total Number of Samples Collected: 2 Most Recent Sample Collected: January 1996

Parameter	Units (Detection Limit)	Average Value	District Percentile	Florida Percentile
Chlorophyll a	ug/l (1)	2.6	19	11
Total Phosphorus	mg/l as P (0.01)	0.015	53	8
Total Nitrogen	mg/l as N (0.06)	1.51	70	61
Transparency (Secchi depth)	meters	3.80	92	>95
Florida Trophic State Index		31	30	6
Specific Conductance	S/cm at 25C (1)	174	47	47
pH	standard units (0.1)	7.2	43	40
Color	PtCo units (1)	8	24	8
Turbidity	NTU (1)	0.5	28	<5
Total Alkalinity	mg/l as CaCO3 (1)	22	45	41
Hardness	mg/l as CaCO3 (0.02)	53	55	
Total Suspended Solids	mg/l (0.05)	2.3	56	
Ammonia	mg/l as N (0.03)	0.042	70	
Nitrate+Nitrite	mg/l as N (0.01)	0.088	80	
Total Kjeldahl Nitrogen	mg/l as N (0.06)	1.42	75	
Orthophosphorus	mg/l as P (0.01)	0.011	64	
Chloride	mg/l (0.05)	14	30	
Sulfate	mg/l (0.05)	29	75	
Sodium	mg/l (0.06)	8.9	51	
Potassium	mg/l (0.07)	6.7	79	
Calcium	mg/l (0.04)	9.6	38	
Magnesium	mg/l (0.006)	7.0	81	
Iron	ug/l (0.03)	54	63	

Based upon the average FTSI of 31, water quality is considered good. Lake Starr can be characterized as a clear (color<=10 color units), soft water, oligotrophic lake. The chemical type of water (predominant ionic composition) is calcium sulfate.

Plots and Trends: Shown are a plot of lake surface elevation and a diagram of the relative ionic composition of the lake water.

MONTHLY AVERAGE SURFACE ELEVATION

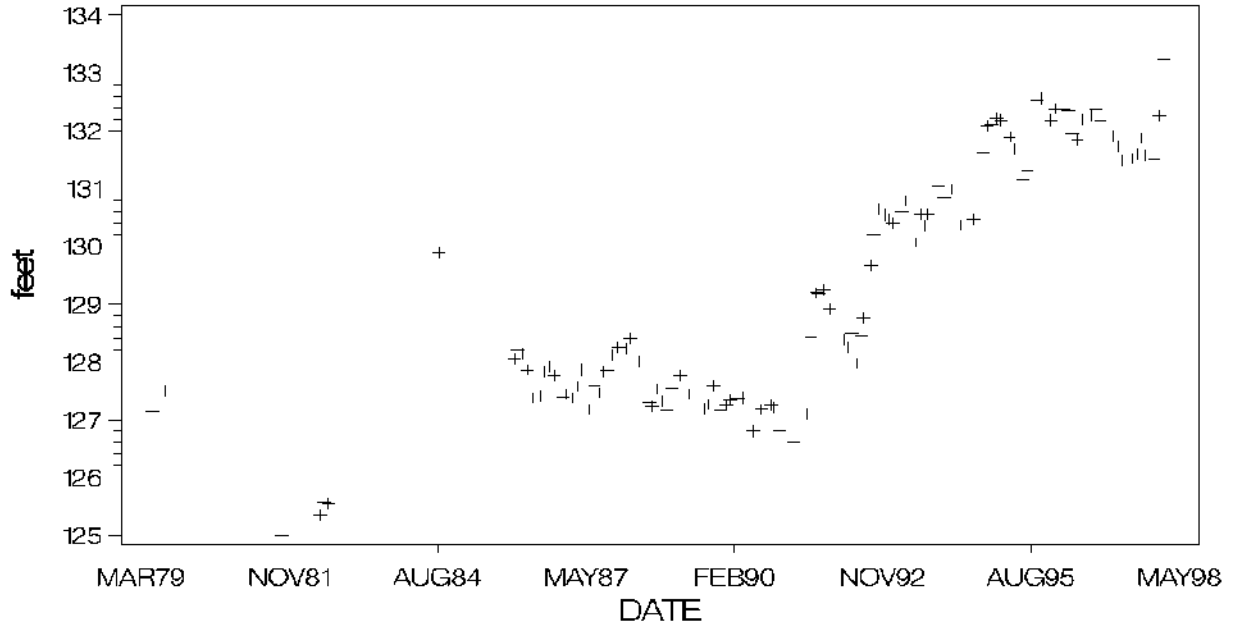

MAJOR IONS (% meq/l)

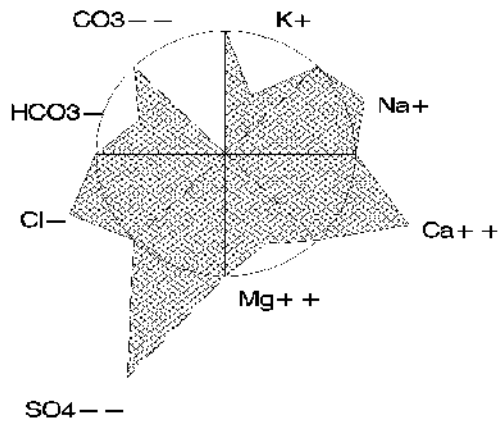

Lake Streety

Polk County

USGS Quadrangle: Frostproof Major Land Use/Land Cover (1990)
 Section/Township/Range: 24-32S-27E within 500 meters of the lakeshore:
 Approx. Lake Center, Lat/Long: 274048/813419 - tree crops, typically citrus (74%)
 Surface Area: 321 acres - stream and lake swamps (14%)
 Approx. Lake Elevation: 106 feet - hardwood - conifer mixed (4%)
 Observed Maximum Depth: 9.8 feet
 (reference elevation not given)
 Lake Type: inflow and outflow (type 3)
 Major Basin: Kissimmee Ridge
 Minor Basin: Livingston Creek
 Lake Region: Southwestern Flatlands
 Public Access: yes

Total Number of Samples Collected: 2 Most Recent Sample Collected: December 1996

Parameter	Units (Detection Limit)	Average Value	District Percentile	Florida Percentile
Chlorophyll a	ug/l (1)	9.5	62	36
Total Phosphorus	mg/l as P (0.01)	0.134	>95	76
Total Nitrogen	mg/l as N (0.06)	0.91	33	30
Transparency (Secchi depth)	meters	0.50	9	20
Florida Trophic State Index		62	86	60
Specific Conductance	S/cm at 25C (1)	124	22	33
pH	standard units (0.1)	6.6	18	20
Color	PtCo units (1)	213	>95	>95
Turbidity	NTU (1)	6.5	79	58
Total Alkalinity	mg/l as CaCO3 (1)	7	18	20
Hardness	mg/l as CaCO3 (0.02)	32	25	
Total Suspended Solids	mg/l (0.05)	3.6	69	
Ammonia	mg/l as N (0.03)	0.015	60	
Nitrate+Nitrite	mg/l as N (0.01)	0.042	66	
Total Kjeldahl Nitrogen	mg/l as N (0.06)	0.87	37	
Orthophosphorus	mg/l as P (0.01)	0.082	>95	
Chloride	mg/l (0.05)	20	56	
Sulfate	mg/l (0.05)	13	45	
Sodium	mg/l (0.06)	7.3	36	
Potassium	mg/l (0.07)	5.7	71	
Calcium	mg/l (0.04)	4.6	12	
Magnesium	mg/l (0.006)	5.0	69	
Iron	ug/l (0.03)	378	>95	

Based upon the average FTSI of 62, water quality is considered fair. Lake Streety can be characterized as a highly colored, soft water, eutrophic lake, with high concentrations of total phosphorus. The chemical type of water (predominant ionic composition) is sodium chloride.

Plots and Trends: No or insufficient data available for plotting or trend detection. Shown is a diagram of the relative ionic composition of the lake water.

MAJOR IONS (% meq/l)

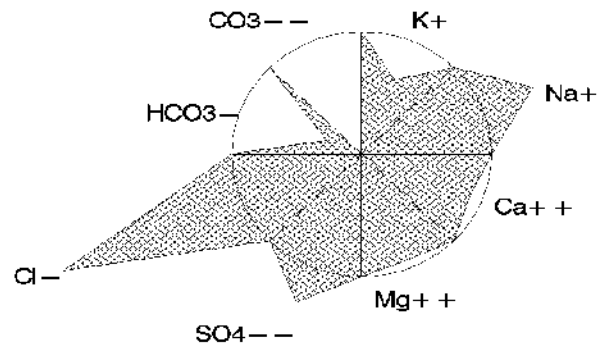

Surveyors Lake Polk County

USGS Quadrangle: Alturas Major Land Use/Land Cover (1990)
 Section/Township/Range: 26-30S-26E within 500 meters of the lakeshore:
 Approx. Lake Center, Lat/Long: 275008/814140 - tree crops, typically citrus (46%)
 Surface Area: 293 acres - cropland and pastureland (33%)
 Approx. Lake Elevation: 133 feet - stream and lake swamps (10%)
 Observed Maximum Depth: 16 feet
 (reference elevation not given)
 Lake Type: outflow (type 2)
 Major Basin: Peace River
 Minor Basin: Lake Pembroke Outlet
 Lake Region: Southwestern Flatlands
 Public Access: yes

Total Number of Samples Collected: 2 Most Recent Sample Collected: December 1996

Parameter	Units (Detection Limit)	Average Value	District Percentile	Florida Percentile
Chlorophyll a	ug/l (1)	37.1	89	72
Total Phosphorus	mg/l as P (0.01)	0.039	83	29
Total Nitrogen	mg/l as N (0.06)	0.98	39	33
Transparency (Secchi depth)	meters	0.63	16	33
Florida Trophic State Index		63	87	61
Specific Conductance	S/cm at 25C (1)	144	33	40
pH	standard units (0.1)	7.3	50	45
Color	PtCo units (1)	85	86	70
Turbidity	NTU (1)	9.3	86	68
Total Alkalinity	mg/l as CaCO3 (1)	14	33	32
Hardness	mg/l as CaCO3 (0.02)	43	41	
Total Suspended Solids	mg/l (0.05)	5.8	81	
Ammonia	mg/l as N (0.03)	0.032	63	
Nitrate+Nitrite	mg/l as N (0.01)	0.005	33	
Total Kjeldahl Nitrogen	mg/l as N (0.06)	0.98	46	
Orthophosphorus	mg/l as P (0.01)	0.008	56	
Chloride	mg/l (0.05)	19	51	
Sulfate	mg/l (0.05)	19	58	
Sodium	mg/l (0.06)	7.1	34	
Potassium	mg/l (0.07)	6.1	73	
Calcium	mg/l (0.04)	6.7	22	
Magnesium	mg/l (0.006)	6.3	78	
Iron	ug/l (0.03)	79	74	

Based upon the average FTSI of 63, water quality is considered fair. Surveyors Lake can be characterized as a highly colored, soft water, eutrophic lake, with high concentrations of total phosphorus. The chemical type of water (predominant ionic composition) is sodium chloride (2 samples) or calcium chloride (1 sample).

Plots and Trends: No or insufficient data available for plotting or trend detection. Shown is a diagram of the relative ionic composition of the lake water.

MAJOR IONS (% meq/l)

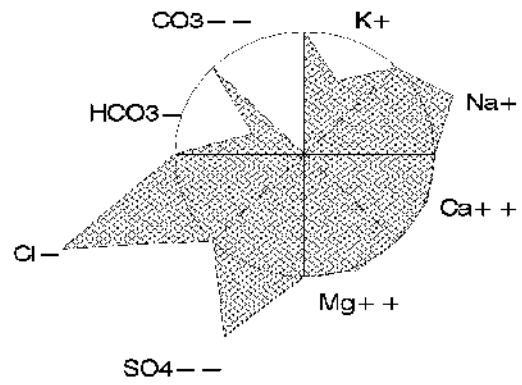

Surveyors Lake, Polk County

Lake Swoope

Polk County

USGS Quadrangle: Winter Haven Major Land Use/Land Cover (1990)
 Section/Township/Range: 29-27S-26E within 500 meters of the lakeshore:
 Approx. Lake Center, Lat/Long: 280607/814331 - tree crops, typically citrus (29%)
 Surface Area: 88 acres - medium density residential (27%)
 Approx. Lake Elevation: 133 feet - wetland forested mixed (15%)
 Observed Maximum Depth: 11 feet
 (reference elevation not given)
 Lake Type: outflow (type 2)
 Major Basin: Peace River
 Minor Basin: Lake Fannie Outlet
 Lake Region: Winter Haven/Lake Henry Ridges
 Public Access: yes

Total Number of Samples Collected: 2 Most Recent Sample Collected: February 1997

Parameter	Units (Detection Limit)	Average Value	District Percentile	Florida Percentile
Chlorophyll a	ug/l (1)	10.1	64	38
Total Phosphorus	mg/l as P (0.01)	0.013	46	7
Total Nitrogen	mg/l as N (0.06)	1.01	41	34
Transparency (Secchi depth)	meters	1.67	55	79
Florida Trophic State Index		44	60	21
Specific Conductance	S/cm at 25C (1)	276	85	65
pH	standard units (0.1)	7.8	74	63
Color	PtCo units (1)	25	62	20
Turbidity	NTU (1)	1.8	47	17
Total Alkalinity	mg/l as CaCO3 (1)	96	>95	84
Hardness	mg/l as CaCO3 (0.02)	84	83	
Total Suspended Solids	mg/l (0.05)	1.8	47	
Ammonia	mg/l as N (0.03)	0.015	60	
Nitrate+Nitrite	mg/l as N (0.01)	0.005	33	
Total Kjeldahl Nitrogen	mg/l as N (0.06)	1.01	48	
Orthophosphorus	mg/l as P (0.01)	0.008	56	
Chloride	mg/l (0.05)	28	82	
Sulfate	mg/l (0.05)	8	31	
Sodium	mg/l (0.06)	20.5	93	
Potassium	mg/l (0.07)	13.5	95	
Calcium	mg/l (0.04)	22.5	82	
Magnesium	mg/l (0.006)	6.7	80	
Iron	ug/l (0.03)	47	59	

Based upon the average FTSI of 44, water quality is considered good. Lake Swoope can be characterized as a moderately colored, medium hard water, eutrophic lake. The chemical type of water (predominant ionic composition) is calcium bicarbonate.

Also of note:

- Cattails dominate more than 30% of the lake shoreline.

Plots and Trends: Lake surface elevation has risen by nearly 4 feet over levels recorded during the period 1970 to 1991. Total phosphorus and Florida TSI are lower than for the observations made during the 1970s, however, there are insufficient data to determine if this change represents a trend. Also shown is a plot of total nitrogen and a diagram of the relative ionic composition of the lake water.

MONTHLY AVERAGE SURFACE ELEVATION

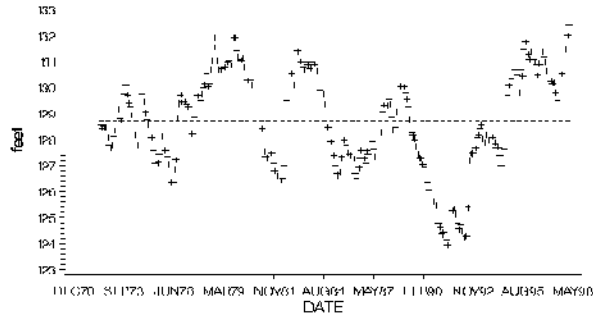

FLORIDA TSI

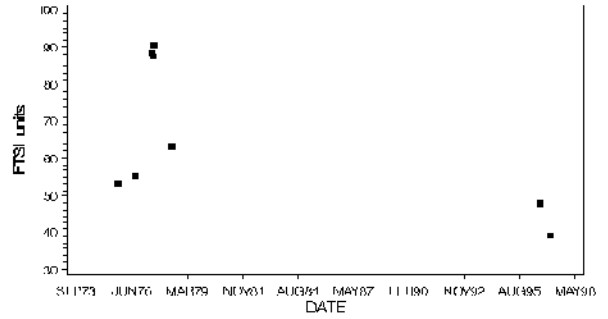

TOTAL NITROGEN

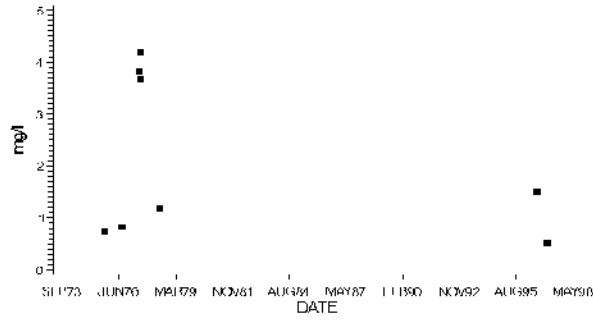

TOTAL PHOSPHORUS

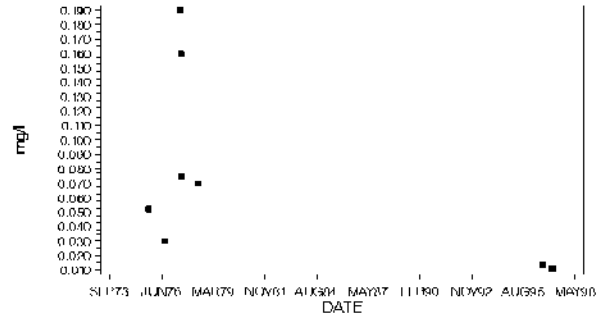

MAJOR IONS (% meq/l)

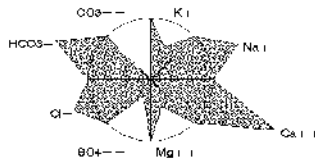

Lake Swoope, Polk County

Lake Tennessee

Polk County

USGS Quadrangle: Polk City Major Land Use/Land Cover (1990)
 Section/Township/Range: 9-27S-25E within 500 meters of the lakeshore:
 Approx. Lake Center, Lat/Long: 280839/814848 - other open lands - rural (68%)
 Surface Area: 112 acres - tree crops, typically citrus (24%)
 Approx. Lake Elevation: 134 feet - low density residential (4%)
 Observed Maximum Depth: 14.1 feet
 (reference elevation not given)
 Lake Type: outflow (type 2)
 Major Basin: Withlacoochee River
 Minor Basin: Lake Juliana Outlet
 Lake Region: Winter Haven/Lake Henry Ridges
 Public Access: yes

Total Number of Samples Collected: 2 Most Recent Sample Collected: January 1997

Parameter	Units (Detection Limit)	Average Value	District Percentile	Florida Percentile
Chlorophyll a	ug/l (1)	48.2	94	81
Total Phosphorus	mg/l as P (0.01)	0.021	66	11
Total Nitrogen	mg/l as N (0.06)	1.46	68	56
Transparency (Secchi depth)	meters	0.60	15	30
Florida Trophic State Index		64	89	64
Specific Conductance	S/cm at 25C (1)	251	78	60
pH	standard units (0.1)	8.7	93	88
Color	PtCo units (1)	10	34	10
Turbidity	NTU (1)	17.1	95	79
Total Alkalinity	mg/l as CaCO3 (1)	39	70	55
Hardness	mg/l as CaCO3 (0.02)	84	83	
Total Suspended Solids	mg/l (0.05)	10.7	91	
Ammonia	mg/l as N (0.03)	0.015	60	
Nitrate+Nitrite	mg/l as N (0.01)	0.008	33	
Total Kjeldahl Nitrogen	mg/l as N (0.06)	1.45	77	
Orthophosphorus	mg/l as P (0.01)	0.009	56	
Chloride	mg/l (0.05)	24	74	
Sulfate	mg/l (0.05)	43	90	
Sodium	mg/l (0.06)	13.5	78	
Potassium	mg/l (0.07)	4.6	62	
Calcium	mg/l (0.04)	10.5	41	
Magnesium	mg/l (0.006)	14.0	95	
Iron	ug/l (0.03)	10	<5	

Based upon the average FTSI of 64, water quality is considered fair. Lake Tennessee can be characterized as a clear (color<=10 color units), medium hard water, hypereutrophic lake. The chemical type of water (predominant ionic composition) is sodium sulfate.

Also of note:

- The measured pH was high.

Plots and Trends: Shown are a plot of lake surface elevation and a diagram of the relative ionic composition of the lake water.

MONTHLY AVERAGE SURFACE ELEVATION

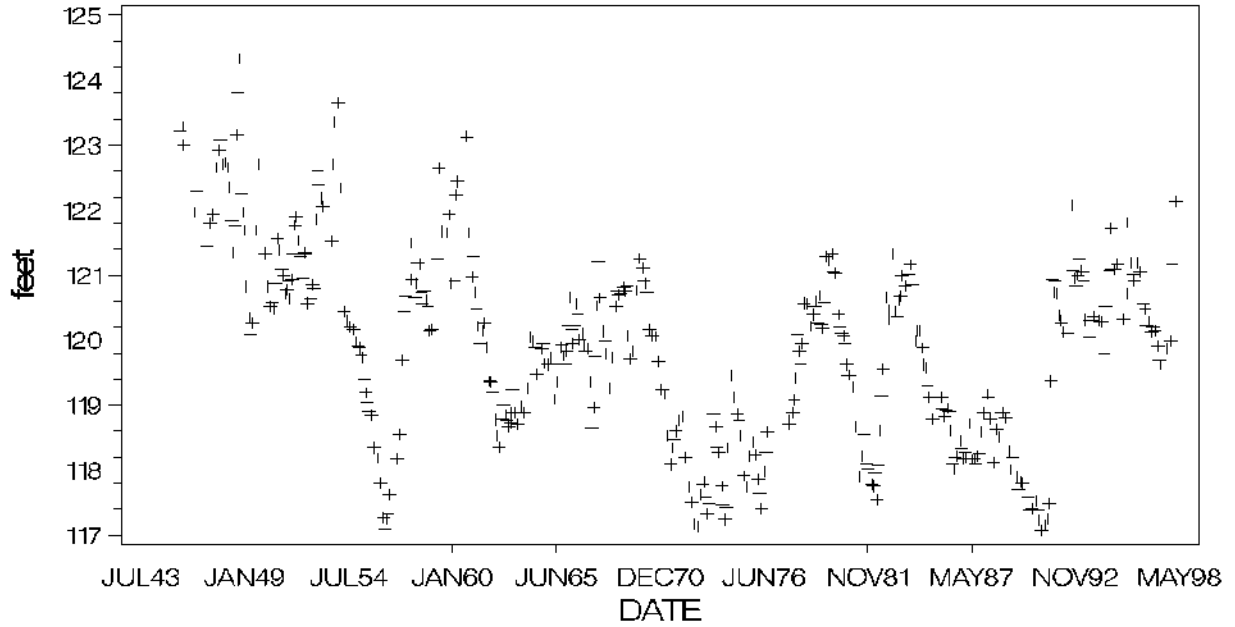

MAJOR IONS (% meq/l)

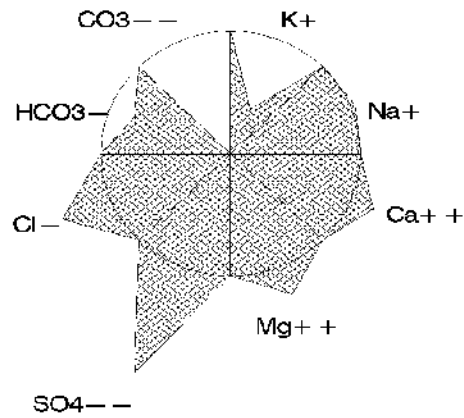

Trout Lake

Polk County

USGS Quadrangle: Frostproof Major Land Use/Land Cover (1990)
 Section/Township/Range: 34-32S-28E within 500 meters of the lakeshore:
 Approx. Lake Center, Lat/Long: 273848/813029 - tree crops, typically citrus (33%)
 Surface Area: 143 acres - low density residential (27%)
 Approx. Lake Elevation: 102 feet - shrub and brushland range (13%)
 Observed Maximum Depth: 25 feet
 (reference elevation not given)
 Lake Type: isolated (type 4)
 Major Basin: Kissimmee Ridge
 Minor Basin: Grassy Creek
 Lake Region: Southern Lake Wales Ridge

Total Number of Samples Collected: 2 Most Recent Sample Collected: January 1995

Parameter	Units (Detection Limit)	Average Value	District Percentile	Florida Percentile
Chlorophyll a	ug/l (1)	2.7	21	11
Total Phosphorus	mg/l as P (0.01)	0.009	31	<5
Total Nitrogen	mg/l as N (0.06)	1.11	49	37
Transparency (Secchi depth)	meters	2.60	77	93
Florida Trophic State Index		28	22	<5
Specific Conductance	S/cm at 25C (1)	127	23	34
pH	standard units (0.1)	7.0	34	30
Color	PtCo units (1)	5	9	5
Turbidity	NTU (1)	1.5	41	13
Total Alkalinity	mg/l as CaCO3 (1)	4	10	10
Hardness	mg/l as CaCO3 (0.02)	31	23	
Total Suspended Solids	mg/l (0.05)	2.0	51	
Ammonia	mg/l as N (0.03)	0.015	60	
Nitrate+Nitrite	mg/l as N (0.01)	0.005	33	
Total Kjeldahl Nitrogen	mg/l as N (0.06)	1.10	55	
Orthophosphorus	mg/l as P (0.01)	0.005	56	
Chloride	mg/l (0.05)	13	27	
Sulfate	mg/l (0.05)	27	73	
Sodium	mg/l (0.06)	6.8	31	
Potassium	mg/l (0.07)	4.1	57	
Calcium	mg/l (0.04)	4.6	12	
Magnesium	mg/l (0.006)	4.7	66	
Iron	ug/l (0.03)	32	41	

Based upon the average FTSI of 28, water quality is considered good. Trout Lake can be characterized as a clear (color<=10 color units), soft water, oligotrophic lake, with low concentrations of total phosphorus. The chemical type of water (predominant ionic composition) is sodium sulfate.

Plots and Trends: The period of continuous record for lake surface elevation is relatively short. Also shown is a diagram of the relative ionic composition of the lake water.

MAJOR IONS (% meq/l)

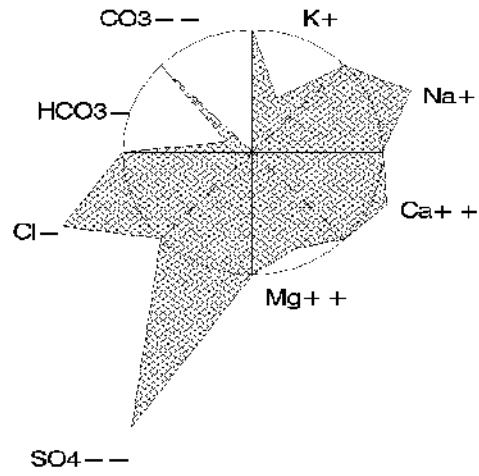

Lake Van

Polk County

USGS Quadrangle: Auburndale Major Land Use/Land Cover (1990)
 Section/Township/Range: 25-27S-25E within 500 meters of the lakeshore:
 Approx. Lake Center, Lat/Long: 280624/814601 - tree crops, typically citrus (56%)
 Surface Area: 592 acres - stream and lake swamps (27%)
 Approx. Lake Elevation: 133 feet - medium density residential (8%)
 Observed Maximum Depth: 15.4 feet
 (reference elevation not given)
 Lake Type: outflow (type 2)
 Major Basin: Withlacoochee River
 Minor Basin: Lake Van Outlet
 Lake Region: Southwestern Flatlands

Total Number of Samples Collected: 2 Most Recent Sample Collected: January 1996

Parameter	Units (Detection Limit)	Average Value	District Percentile	Florida Percentile
Chlorophyll a	ug/l (1)	15.4	74	46
Total Phosphorus	mg/l as P (0.01)	0.054	88	42
Total Nitrogen	mg/l as N (0.06)	1.30	61	45
Transparency (Secchi depth)	meters	0.60	15	30
Florida Trophic State Index		60	83	54
Specific Conductance	S/cm at 25C (1)	231	71	57
pH	standard units (0.1)	6.6	18	20
Color	PtCo units (1)	98	89	76
Turbidity	NTU (1)	14.9	93	76
Total Alkalinity	mg/l as CaCO3 (1)	9	24	24
Hardness	mg/l as CaCO3 (0.02)	56	58	
Total Suspended Solids	mg/l (0.05)	21.2	>95	
Ammonia	mg/l as N (0.03)	0.110	89	
Nitrate+Nitrite	mg/l as N (0.01)	0.061	73	
Total Kjeldahl Nitrogen	mg/l as N (0.06)	1.24	64	
Orthophosphorus	mg/l as P (0.01)	0.045	93	
Chloride	mg/l (0.05)	31	87	
Sulfate	mg/l (0.05)	37	86	
Sodium	mg/l (0.06)	15.5	85	
Potassium	mg/l (0.07)	11.5	92	
Calcium	mg/l (0.04)	6.1	20	
Magnesium	mg/l (0.006)	9.9	87	
Iron	ug/l (0.03)	207	93	

Based upon the average FTSI of 60, water quality is considered good. Lake Van can be characterized as a highly colored, soft water, eutrophic lake, with high concentrations of total phosphorus. The chemical type of water (predominant ionic composition) is sodium chloride.

Plots and Trends: The period of continuous record for lake surface elevation is relatively short. Also shown is a diagram of the relative ionic composition of the lake water.

MONTHLY AVERAGE SURFACE ELEVATION

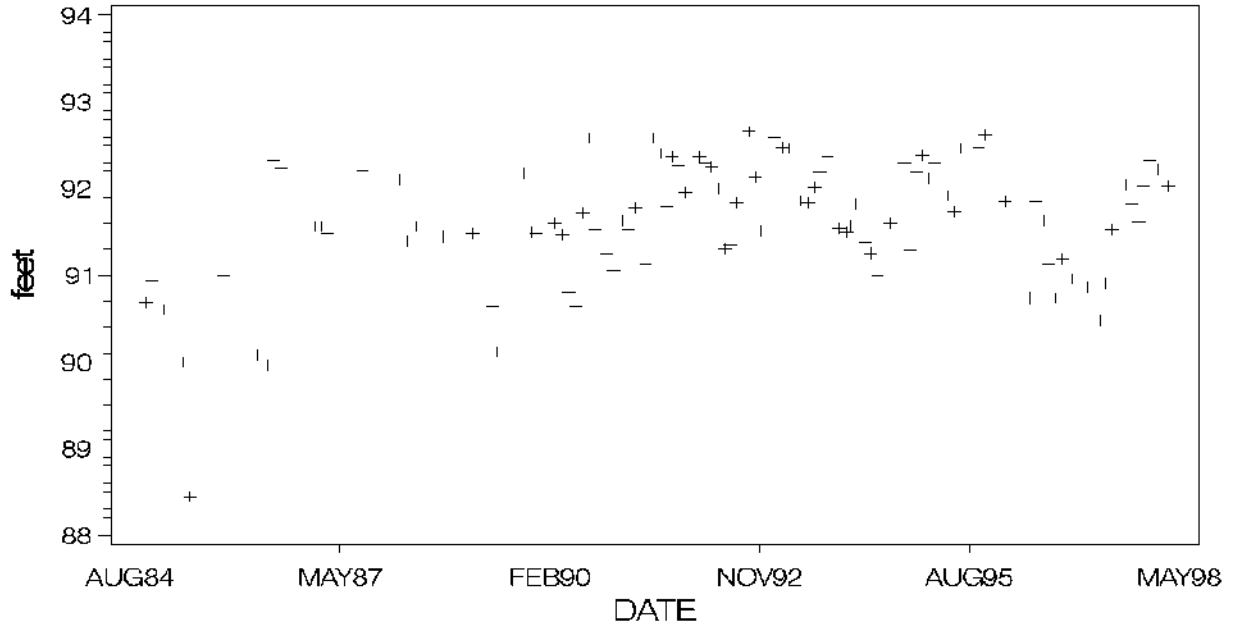

MAJOR IONS (% meq/l)

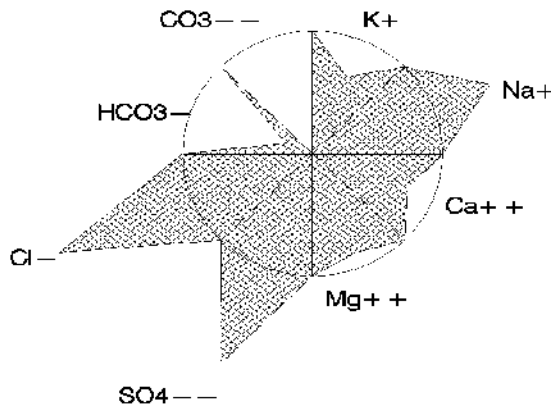

Lake Wales

Polk County

USGS Quadrangle: Lake Wales Major Land Use/Land Cover (1990)
 Section/Township/Range: 1-30S-27E within 500 meters of the lakeshore:
 Approx. Lake Center, Lat/Long: 275405/813420 - medium density residential (72%)
 Surface Area: 326 acres - recreational (14%)
 Approx. Lake Elevation: 113 feet - transportation (4%)
 Observed Maximum Depth: 16.4 feet
 (reference elevation 105 feet)
 Lake Type: isolated (type 4)
 Major Basin: Kissimmee Ridge
 Minor Basin: Lake Weohyakapka
 Lake Region: Northern Lake Wales Ridge
 Public Access: yes

Total Number of Samples Collected: 2 Most Recent Sample Collected: January 1997

Parameter	Units (Detection Limit)	Average Value	District Percentile	Florida Percentile
Chlorophyll a	ug/l (1)	5.9	49	25
Total Phosphorus	mg/l as P (0.01)	0.005	31	<5
Total Nitrogen	mg/l as N (0.06)	0.95	37	32
Transparency (Secchi depth)	meters	2.05	65	86
Florida Trophic State Index		31	30	6
Specific Conductance	S/cm at 25C (1)	146	35	41
pH	standard units (0.1)	8.2	85	75
Color	PtCo units (1)	8	24	8
Turbidity	NTU (1)	1.5	41	13
Total Alkalinity	mg/l as CaCO3 (1)	44	76	59
Hardness	mg/l as CaCO3 (0.02)	60	62	
Total Suspended Solids	mg/l (0.05)	2.0	51	
Ammonia	mg/l as N (0.03)	0.059	79	
Nitrate+Nitrite	mg/l as N (0.01)	0.005	33	
Total Kjeldahl Nitrogen	mg/l as N (0.06)	0.94	42	
Orthophosphorus	mg/l as P (0.01)	0.005	56	
Chloride	mg/l (0.05)	10	15	
Sulfate	mg/l (0.05)	11	39	
Sodium	mg/l (0.06)	5.6	18	
Potassium	mg/l (0.07)	1.6	27	
Calcium	mg/l (0.04)	17.5	67	
Magnesium	mg/l (0.006)	3.8	56	
Iron	ug/l (0.03)	13	6	

Based upon the average FTSI of 31, water quality is considered good. Lake Wales can be characterized as a clear (color<=10 color units), soft water, mesotrophic lake, with low concentrations of total phosphorus. The chemical type of water (predominant ionic composition) is calcium bicarbonate.

Also of note:

- The measured pH was high.
- Hydrilla was observed in the lake.
- Cattails dominate more than 30% of the lake shoreline.

Plots and Trends: The range in lake surface elevation fluctuation was about 12 feet over the period of record. Plots of water chemistry show that recent measurements and concentrations are within the historical ranges. Also shown is a diagram of the relative ionic composition of the lake water.

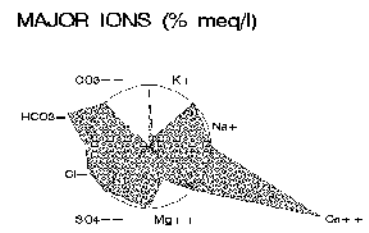
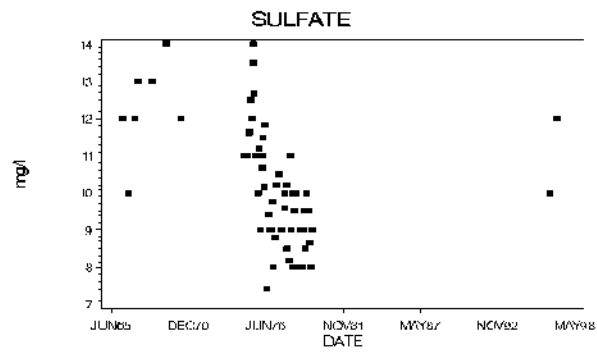
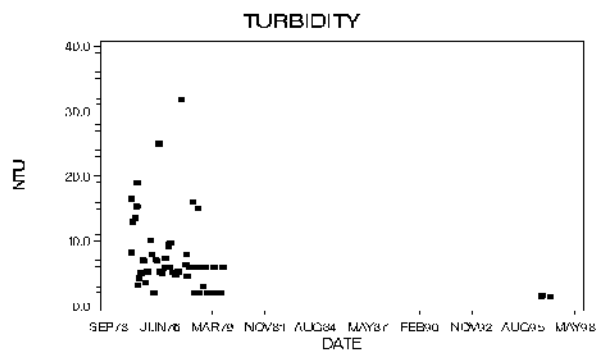
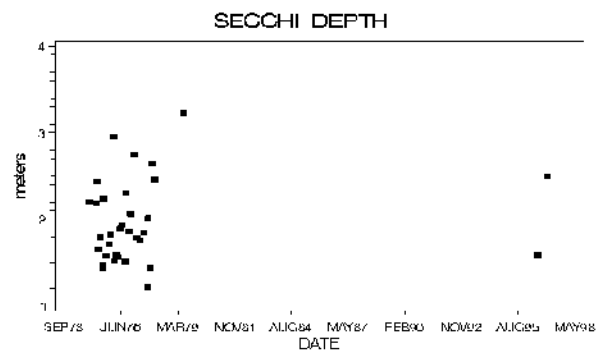
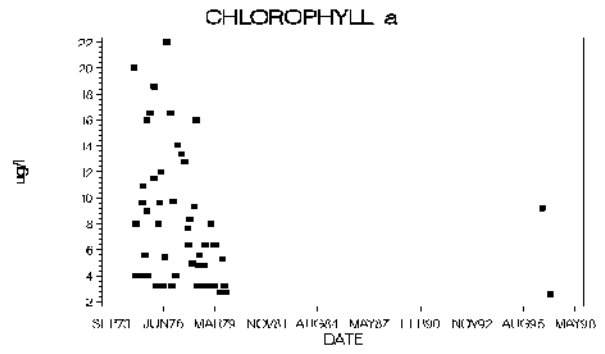
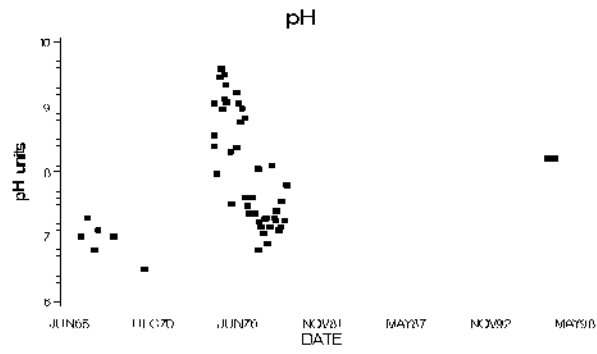
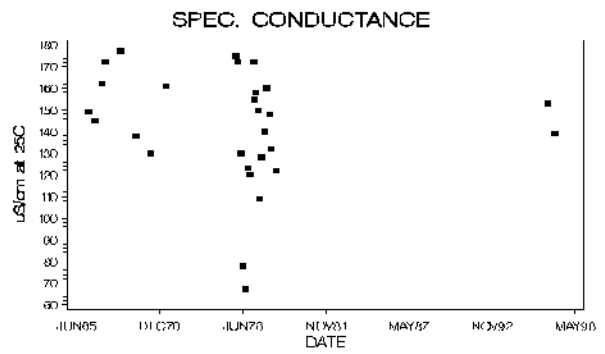
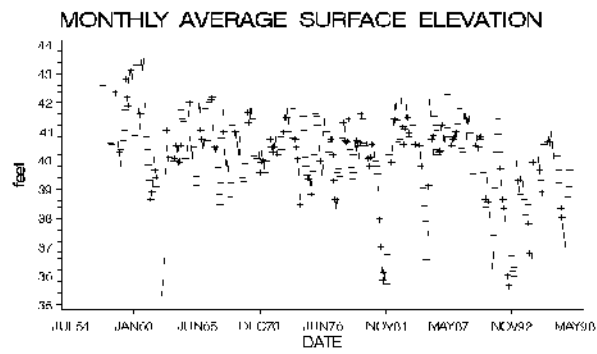

Lake Wales, Polk County

Lake Winterset Polk County

USGS Quadrangle:	Eloise	Major Land Use/Land Cover (1990)
Section/Township/Range:	11-29S-26E	within 500 meters of the lakeshore:
Approx. Lake Center, Lat/Long:	275825/814056	- tree crops, typically citrus (40%)
Surface Area:	548 acres	- medium density residential (18%)
Approx. Lake Elevation:	132 feet	- open land (8%)
Average Depth: 15 feet		
Observed Maximum Depth: 22 feet		
(reference elevation 130 feet)		
Lake Type: outflow (type 2)		
Major Basin: Peace River		
Minor Basin: Lake Lulu Outlet		
Lake Region: Winter Haven/Lake Henry Ridges		
Public Access: yes		

Total Number of Samples Collected: 2 Most Recent Sample Collected: January 1997

Parameter	Units (Detection Limit)	Average Value	District Percentile	Florida Percentile
Chlorophyll a	ug/l (1)	11.1	68	40
Total Phosphorus	mg/l as P (0.01)	0.013	46	7
Total Nitrogen	mg/l as N (0.06)	1.26	58	43
Transparency (Secchi depth)	meters	1.44	48	75
Florida Trophic State Index		44	61	22
Specific Conductance	S/cm at 25C (1)	282	85	66
pH	standard units (0.1)	8.0	81	70
Color	PtCo units (1)	8	24	8
Turbidity	NTU (1)	2.9	62	31
Total Alkalinity	mg/l as CaCO3 (1)	48	78	61
Hardness	mg/l as CaCO3 (0.02)	81	80	
Total Suspended Solids	mg/l (0.05)	1.7	44	
Ammonia	mg/l as N (0.03)	0.015	60	
Nitrate+Nitrite	mg/l as N (0.01)	0.015	44	
Total Kjeldahl Nitrogen	mg/l as N (0.06)	1.25	65	
Orthophosphorus	mg/l as P (0.01)	0.012	68	
Chloride	mg/l (0.05)	29	83	
Sulfate	mg/l (0.05)	38	87	
Sodium	mg/l (0.06)	17.5	89	
Potassium	mg/l (0.07)	7.4	83	
Calcium	mg/l (0.04)	20.0	75	
Magnesium	mg/l (0.006)	7.6	82	
Iron	ug/l (0.03)	113	85	

Based upon the average FTSI of 44, water quality is considered good. Lake Winterset can be characterized as a clear (color<=10 color units), medium hard water, eutrophic lake. The chemical type of water (predominant ionic composition) is calcium chloride.

Also of note:

- The measured pH was high.

Plots and Trends: The plots of water chemistry for Lake Winterset demonstrate no clear trends. Also shown is a diagram of the relative ionic composition of the lake water.

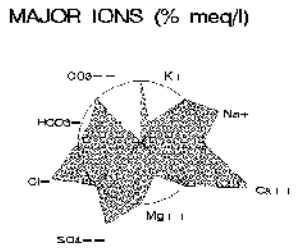
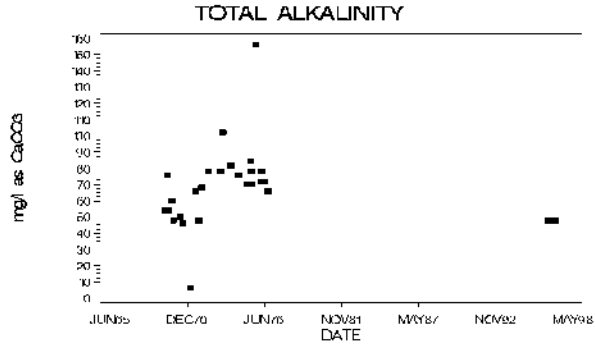
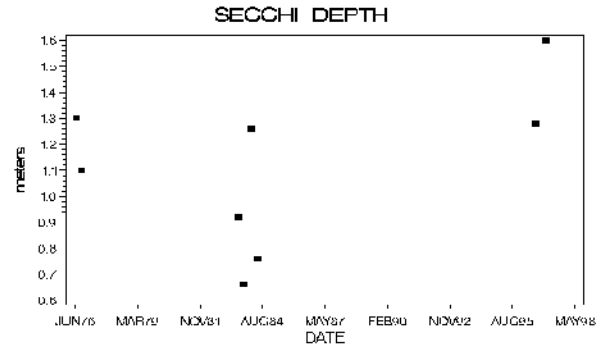
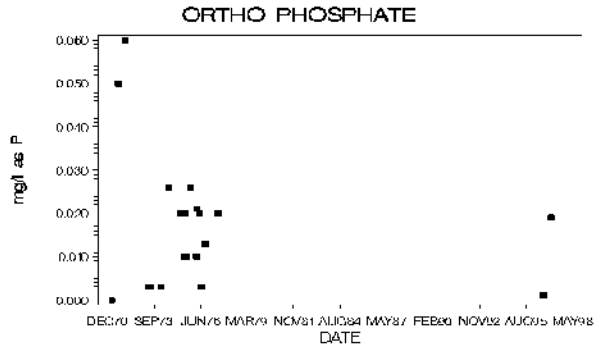
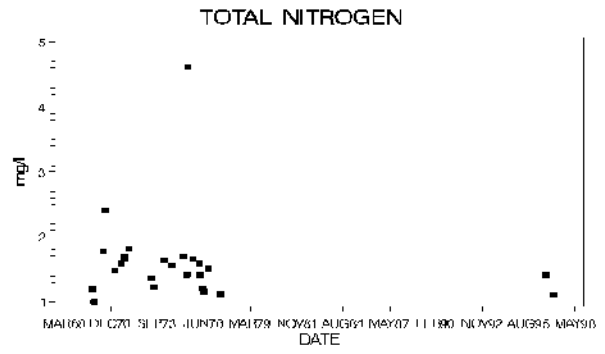
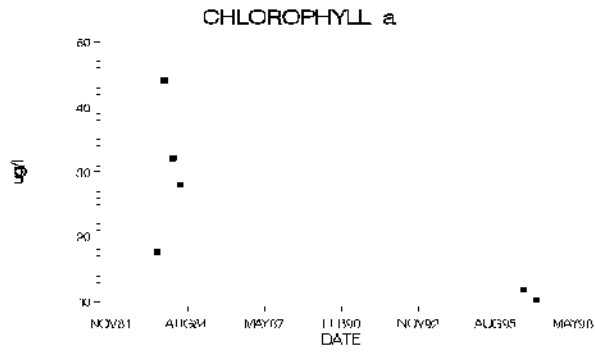
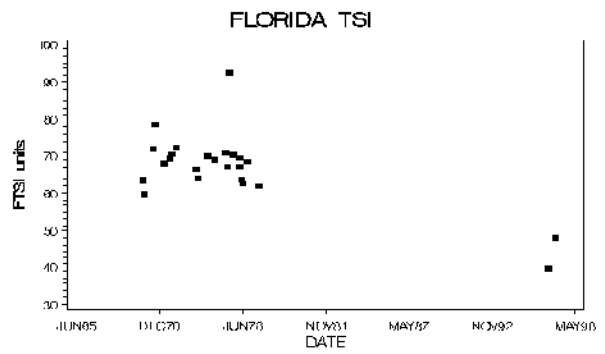
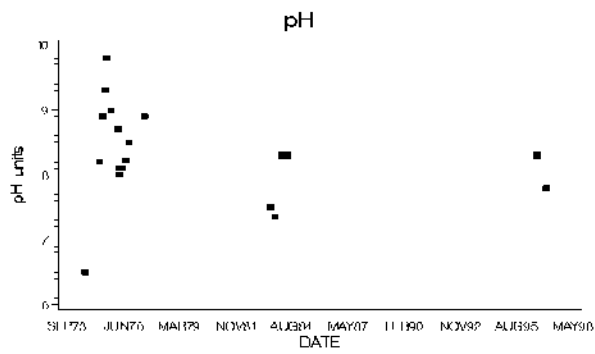

Lake Winterset, Polk County

Big Gant Lake Sumter County

USGS Quadrangle:	Webster	Major Land Use/Land Cover (1990)
Section/Township/Range:	14-22S-22E	within 500 meters of the lakeshore:
Approx. Lake Center, Lat/Long:	283434/820507	- cropland and pastureland (44%)
Surface Area:	93 acres	- stream and lake swamps (25%)
Approx. Lake Elevation:	76 feet	- other open lands - rural (7%)
Average Depth: 2 feet		
Observed Maximum Depth: 3 feet (reference elevation 74.2 feet)		
Lake Type: inflow and outflow (type 3)		
Major Basin: Withlacoochee River		
Minor Basin: Big Gant Canal		
Lake Region: Webster Dry Plain		
Public Access: yes		

Total Number of Samples Collected: 2 Most Recent Sample Collected: January 1996

Parameter	Units (Detection Limit)	Average Value	District Percentile	Florida Percentile
Chlorophyll a	ug/l (1)	7.3	54	31
Total Phosphorus	mg/l as P (0.01)	0.049	86	40
Total Nitrogen	mg/l as N (0.06)	1.23	56	42
Transparency (Secchi depth)	meters	1.22	41	70
Florida Trophic State Index		51	75	37
Specific Conductance	S/cm at 25C (1)	295	87	68
pH	standard units (0.1)	7.2	43	40
Color	PtCo units (1)	50	79	40
Turbidity	NTU (1)	3.5	67	37
Total Alkalinity	mg/l as CaCO3 (1)	217	>95	>95
Hardness	mg/l as CaCO3 (0.02)	135	>95	
Total Suspended Solids	mg/l (0.05)	2.8	62	
Ammonia	mg/l as N (0.03)	0.070	82	
Nitrate+Nitrite	mg/l as N (0.01)	0.017	46	
Total Kjeldahl Nitrogen	mg/l as N (0.06)	1.21	63	
Orthophosphorus	mg/l as P (0.01)	0.025	88	
Chloride	mg/l (0.05)	11	19	
Sulfate	mg/l (0.05)	3	14	
Sodium	mg/l (0.06)	6.0	22	
Potassium	mg/l (0.07)	0.8	16	
Calcium	mg/l (0.04)	51.0	>95	
Magnesium	mg/l (0.006)	1.9	23	
Iron	ug/l (0.03)	757	>95	

Based upon the average FTSI of 51, water quality is considered good. Big Gant Lake can be characterized as a colored, hard water, meso-eutrophic lake, with high concentrations of total phosphorus. The chemical type of water (predominant ionic composition) is calcium bicarbonate.

Also of note:

- Cattails dominate more than 30% of the lake shoreline.

Plots and Trends: No or insufficient data for plotting or trend detection. Shown is a diagram of the relative ionic composition of the lake water.

MAJOR IONS (% meq/l)

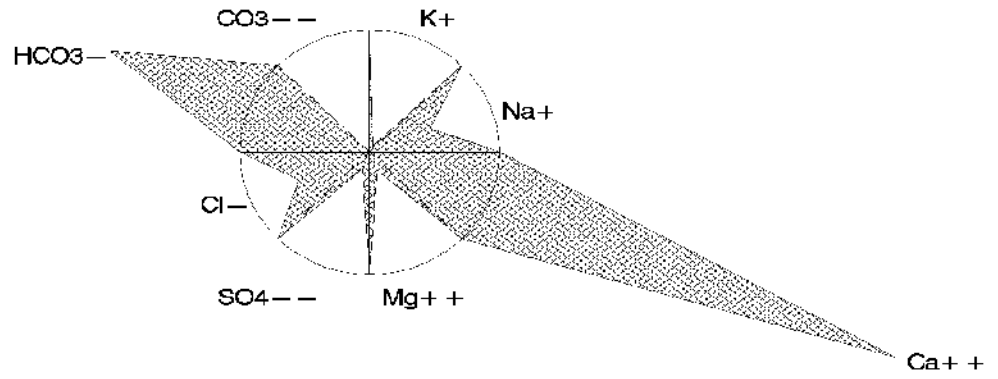

Big Gant Lake, Sumter County

Lake Deaton

Sumter County

USGS Quadrangle: Leesburg West Major Land Use/Land Cover (1990)
 Section/Township/Range: 14-19S-23E within 500 meters of the lakeshore:
 Approx. Lake Center, Lat/Long: 285006/815858 - cropland and pastureland (45%)
 Surface Area: 778 acres - stream and lake swamps (15%)
 Approx. Lake Elevation: 65 feet - freshwater marshes (14%)
 Average Depth: 4.8 feet
 Observed Maximum Depth: 8 feet
 (reference elevation 61.6 feet)
 Lake Type: inflow (type 1)
 Major Basin: Withlacoochee River
 Minor Basin: Lake Deaton Outlet
 Lake Region: Central Valley
 Public Access: yes

Total Number of Samples Collected: 2 Most Recent Sample Collected: January 1996

Parameter	Units (Detection Limit)	Average Value	District Percentile	Florida Percentile
Chlorophyll a	ug/l (1)	23.3	82	56
Total Phosphorus	mg/l as P (0.01)	0.022	68	12
Total Nitrogen	mg/l as N (0.06)	1.82	79	76
Transparency (Secchi depth)	meters	0.71	19	41
Florida Trophic State Index		60	84	56
Specific Conductance	S/cm at 25C (1)	171	46	46
pH	standard units (0.1)	7.6	64	57
Color	PtCo units (1)	23	58	19
Turbidity	NTU (1)	9.7	87	69
Total Alkalinity	mg/l as CaCO3 (1)	23	46	42
Hardness	mg/l as CaCO3 (0.02)	30	21	
Total Suspended Solids	mg/l (0.05)	9.1	89	
Ammonia	mg/l as N (0.03)	0.025	60	
Nitrate+Nitrite	mg/l as N (0.01)	0.005	33	
Total Kjeldahl Nitrogen	mg/l as N (0.06)	1.81	85	
Orthophosphorus	mg/l as P (0.01)	0.016	82	
Chloride	mg/l (0.05)	34	90	
Sulfate	mg/l (0.05)	3	14	
Sodium	mg/l (0.06)	20.5	93	
Potassium	mg/l (0.07)	2.8	45	
Calcium	mg/l (0.04)	5.9	19	
Magnesium	mg/l (0.006)	3.8	56	
Iron	ug/l (0.03)	46	58	

Based upon the average FTSI of 60, water quality is considered good. Lake Deaton can be characterized as a moderately colored, soft water, eutrophic lake, with high concentrations of total nitrogen. The chemical type of water (predominant ionic composition) is sodium chloride.

Also of note:

- Cattails dominate more than 30% of the lake shoreline.

Plots and Trends: The plot of lake elevation shows a period from 1977 through 1981 when lake levels were markedly lower than for the period after 1981. Lake levels in nearby Lake Okahumpka, which usually mirror lake level fluctuations in Lake Deaton, do not demonstrate the same depressed levels between 1977 and 1981. Therefore, the low levels in Lake Deaton from 1977 through 1981 may be due to drainage alterations. Also shown is a diagram of the relative ionic composition of the lake water.

MONTHLY AVERAGE SURFACE ELEVATION

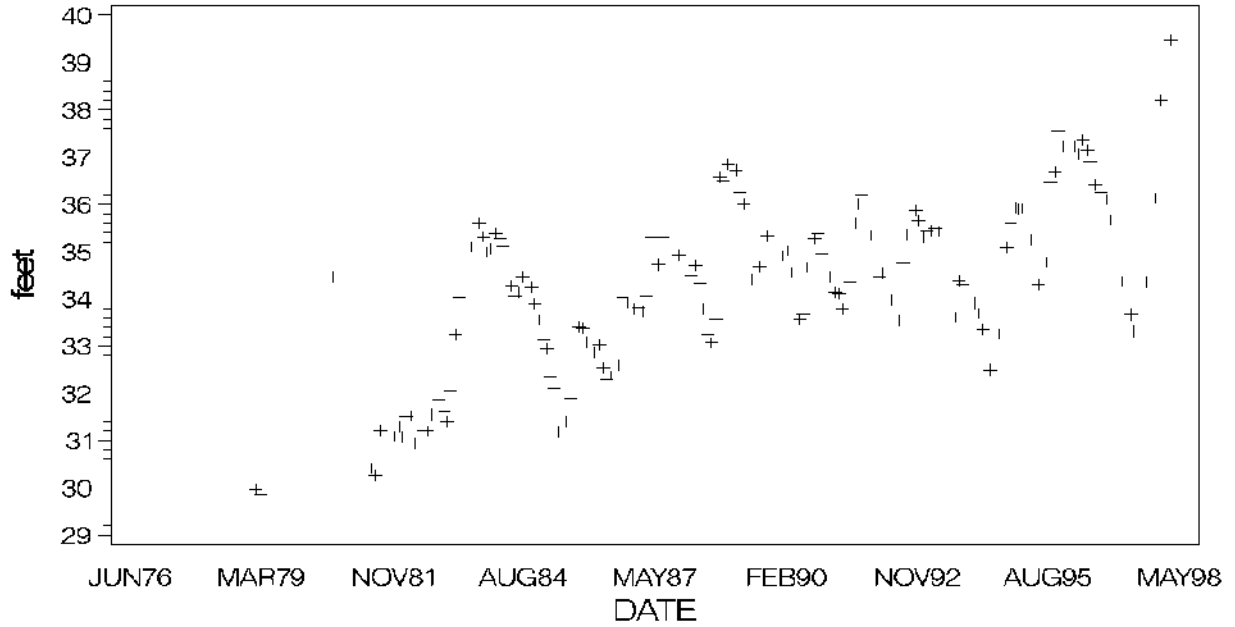

MAJOR IONS (% meq/l)

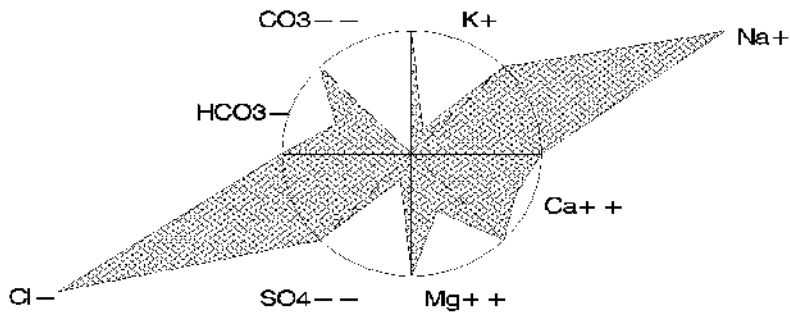

Lake Miona

Sumter County

USGS Quadrangle: Oxford Major Land Use/Land Cover (1990)
 Section/Township/Range: 27-18S-23E within 500 meters of the lakeshore:
 Approx. Lake Center, Lat/Long: 285409/820017 - cropland and pastureland (34%)
 Surface Area: 418 acres - wet prairies (26%)
 Approx. Lake Elevation: 56 feet - recreational (16%)
 Average Depth: 6.7 feet
 Observed Maximum Depth: 16 feet
 (reference elevation 56 feet)
 Lake Type: isolated (type 4)
 Major Basin: Withlacoochee River
 Minor Basin: Lake Miona Outlet
 Lake Region: Central Valley
 Public Access: yes

Total Number of Samples Collected: 2 Most Recent Sample Collected: January 1996

Parameter	Units (Detection Limit)	Average Value	District Percentile	Florida Percentile
Chlorophyll a	ug/l (1)	13.1	71	43
Total Phosphorus	mg/l as P (0.01)	0.028	75	18
Total Nitrogen	mg/l as N (0.06)	2.26	89	85
Transparency (Secchi depth)	meters	0.54	12	24
Florida Trophic State Index		60	84	56
Specific Conductance	S/cm at 25C (1)	168	45	46
pH	standard units (0.1)	7.8	74	63
Color	PtCo units (1)	20	55	17
Turbidity	NTU (1)	9.8	87	69
Total Alkalinity	mg/l as CaCO3 (1)	33	64	51
Hardness	mg/l as CaCO3 (0.02)	45	46	
Total Suspended Solids	mg/l (0.05)	8.4	88	
Ammonia	mg/l as N (0.03)	0.093	86	
Nitrate+Nitrite	mg/l as N (0.01)	0.019	50	
Total Kjeldahl Nitrogen	mg/l as N (0.06)	2.25	94	
Orthophosphorus	mg/l as P (0.01)	0.029	90	
Chloride	mg/l (0.05)	23	69	
Sulfate	mg/l (0.05)	10	37	
Sodium	mg/l (0.06)	14.0	80	
Potassium	mg/l (0.07)	2.6	42	
Calcium	mg/l (0.04)	13.5	54	
Magnesium	mg/l (0.006)	2.8	41	
Iron	ug/l (0.03)	14	8	

Based upon the average FTSI of 60, water quality is considered fair. Lake Miona can be characterized as a moderately colored, soft water, meso-eutrophic lake, with high concentrations of total nitrogen. The chemical type of water (predominant ionic composition) is calcium chloride.

Plots and Trends: Lake levels in Lake Miona declined over a ten year period between 1984 and 1994. Recent levels were similar to those at the beginning of the period of record. Also shown is a diagram of the relative ionic composition of the lake water.

MONTHLY AVERAGE SURFACE ELEVATION

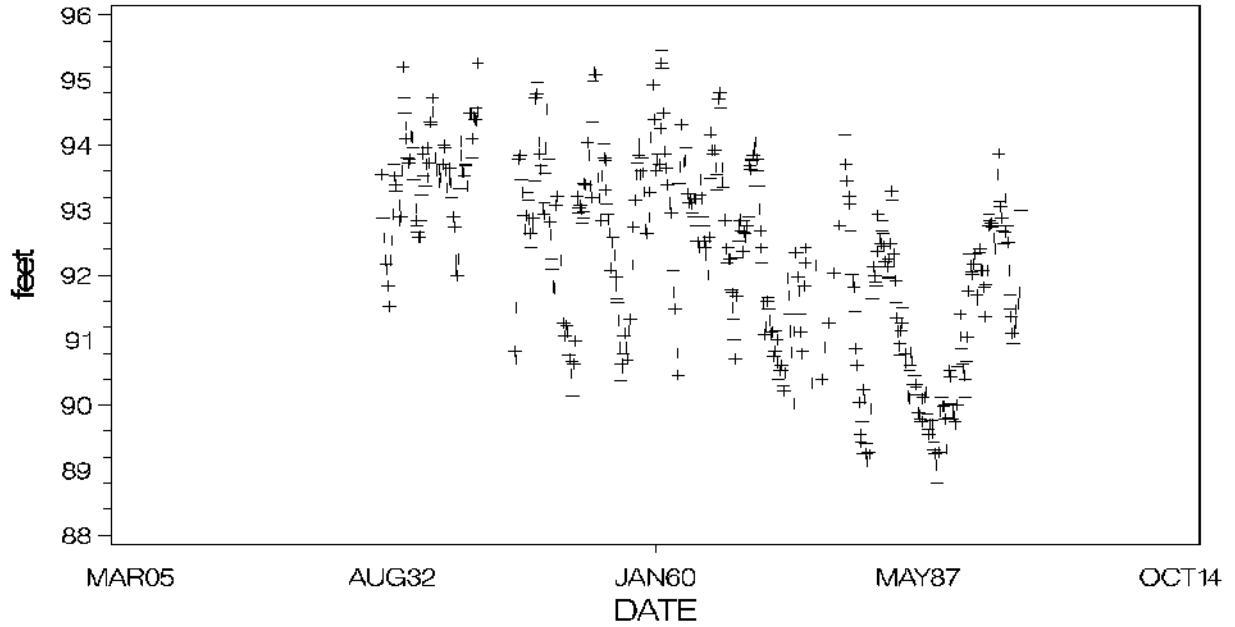

MAJOR IONS (% meq/l)

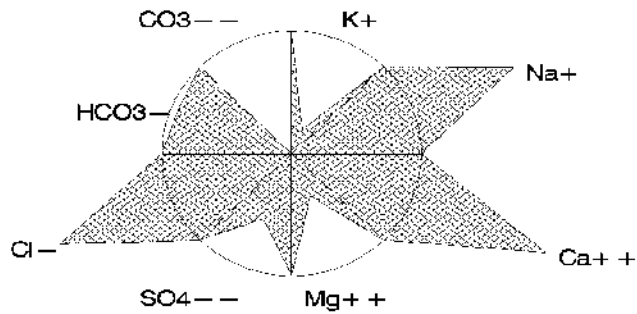

Lake Okahumpka Sumter County

USGS Quadrangle: Wildwood Major Land Use/Land Cover (1990)
 Section/Township/Range: 21-19S-23E within 500 meters of the lakeshore:
 Approx. Lake Center, Lat/Long: 284928/820027 - hardwood - conifer mixed (33%)
 Surface Area: 670 acres - stream and lake swamps (27%)
 Approx. Lake Elevation: 59 feet - medium density residential (16%)
 Average Depth: 4.1 feet
 Observed Maximum Depth: 6 feet
 (reference elevation 57.2 feet)
 Lake Type: inflow and outflow (type 3)
 Major Basin: Withlacoochee River
 Minor Basin: Lake Okahumpka Outlet
 Lake Region: Central Valley
 Public Access: yes

Total Number of Samples Collected: 2 Most Recent Sample Collected: January 1996

Parameter	Units (Detection Limit)	Average Value	District Percentile	Florida Percentile
Chlorophyll a	ug/l (1)	3.1	26	13
Total Phosphorus	mg/l as P (0.01)	0.022	68	12
Total Nitrogen	mg/l as N (0.06)	1.12	50	37
Transparency (Secchi depth)	meters	1.69	56	80
Florida Trophic State Index		38	50	14
Specific Conductance	S/cm at 25C (1)	258	79	61
pH	standard units (0.1)	7.5	61	53
Color	PtCo units (1)	28	65	22
Turbidity	NTU (1)	1.0	29	5
Total Alkalinity	mg/l as CaCO3 (1)	65	89	70
Hardness	mg/l as CaCO3 (0.02)	72	74	
Total Suspended Solids	mg/l (0.05)	1.0	28	
Ammonia	mg/l as N (0.03)	0.025	60	
Nitrate+Nitrite	mg/l as N (0.01)	0.011	37	
Total Kjeldahl Nitrogen	mg/l as N (0.06)	1.11	56	
Orthophosphorus	mg/l as P (0.01)	0.008	56	
Chloride	mg/l (0.05)	36	93	
Sulfate	mg/l (0.05)	4	17	
Sodium	mg/l (0.06)	21.0	93	
Potassium	mg/l (0.07)	3.7	51	
Calcium	mg/l (0.04)	21.5	80	
Magnesium	mg/l (0.006)	4.4	61	
Iron	ug/l (0.03)	154	89	

Based upon the average FTSI of 38, water quality is considered good. Lake Okahumpka can be characterized as a moderately colored, medium hard water, oligo-mesotrophic lake. The chemical type of water (predominant ionic composition) is calcium chloride.

Also of note:

- Cattails dominate more than 30% of the lake shoreline.

Plots and Trends: There is no long-term trend in elevation apparent in the plot. Also shown is a diagram of the relative ionic composition of the lake water.

MONTHLY AVERAGE SURFACE ELEVATION

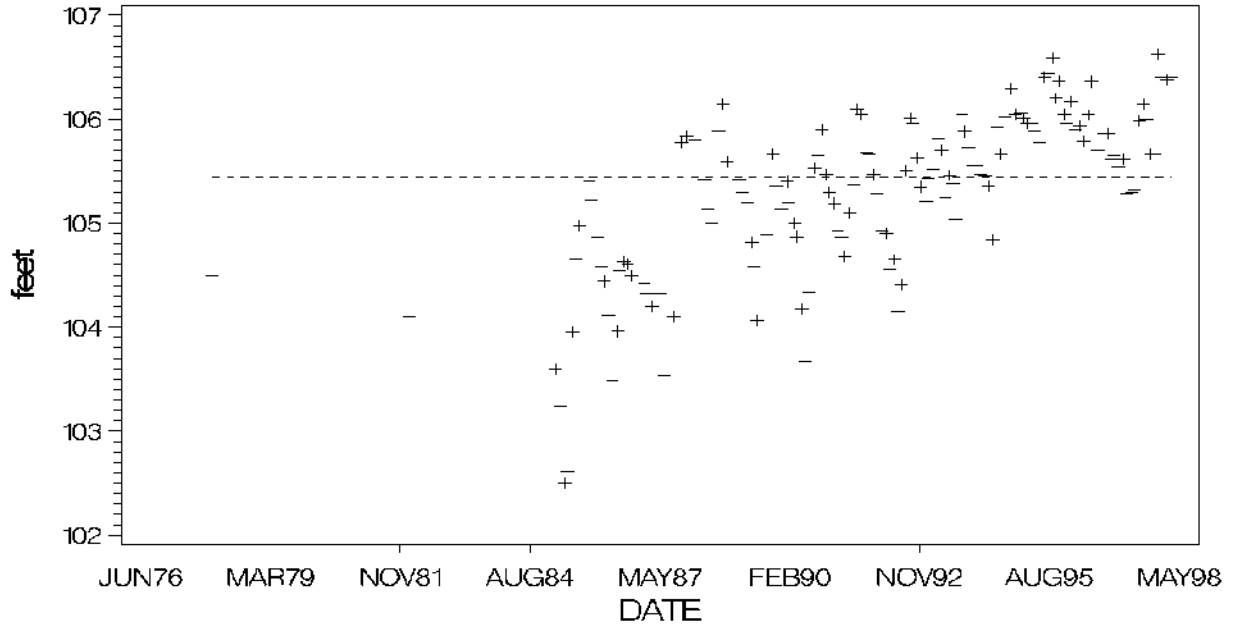

MAJOR IONS (% meq/l)

