

FFA Officer Duties = Prezi

Bradshaw Feed and Pet Supply

7285 Bradshaw Rd, Sacramento Ca, 95829

• If you are set up for chickens already, Here is what Bradshaw's has:

• Black Australorp = Annabelle



• Black Sex Link



• Golden Sex Link



• New Hampshire Red

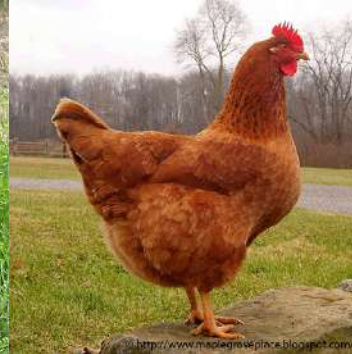

• Barred Rock



• Buff Orpington



• Rhode Island Red



• Light Brahma



• This is what you need: Watering can \$10 – 30, Feeder \$10 – 30, Feed \$18/50#, Enclosure, Nesting box \$16.

Biology

UNIT Genetic Inheritance

October 31st – November 4th

The rule of unit factors

Mendel concluded that each organism has two factors that control each of its traits.

We now know that these factors are genes and that they are located on chromosomes.

1. Genes exist in alternative forms. We call these different gene forms **alleles.**

Pea Plant – Round – R

- wrinkled – r

Hybrid - Rr

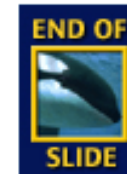

The rule of dominance

2. Mendel called the observed trait **dominant** and the trait that disappeared **recessive**.

Pea Plant – Round – R
- wrinkled - r

Mendel concluded that the allele for tall plants is dominant to the allele for short plants.

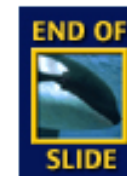

The rule of dominance

When recording the results of crosses, it is customary to use the same letter for different alleles of the same gene.

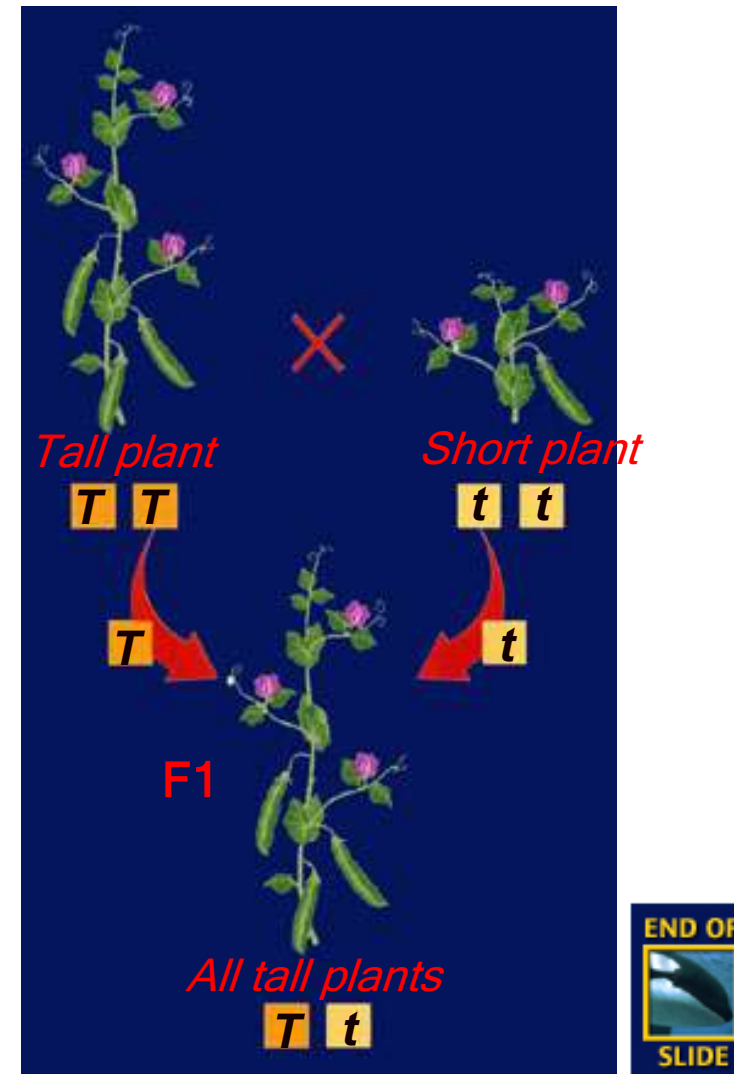

Chromosomes Page 73 NB

- *Humans have 23 pairs of chromosomes (46 all together)
- *autosomes: there are equal numbers of copies in males and females (22 pairs, 44 total)
- *sex chromosomes: Chromosomes that determine the sex of the organism (1 pair, 2 total); XX=female XY=male

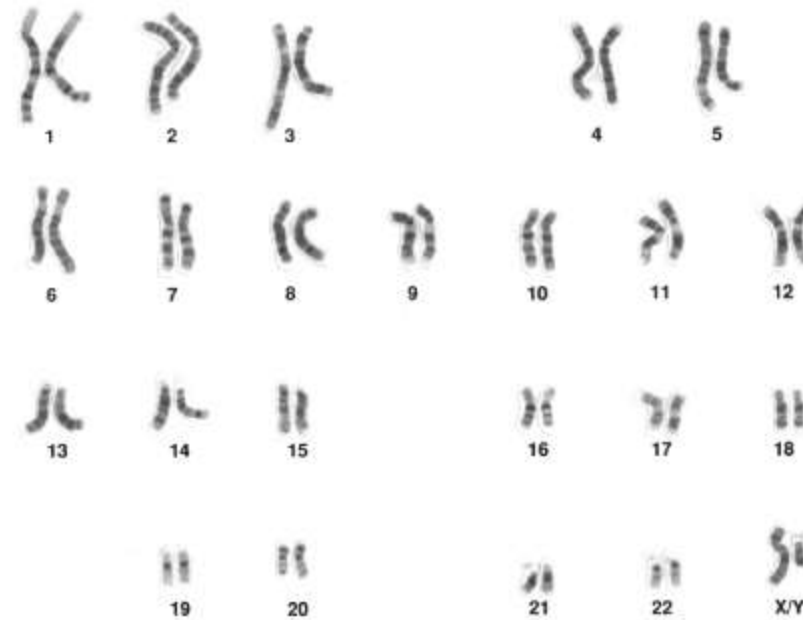

Female Karyotype

- *Karyotype: the complete set of chromosome in the cells of an organism

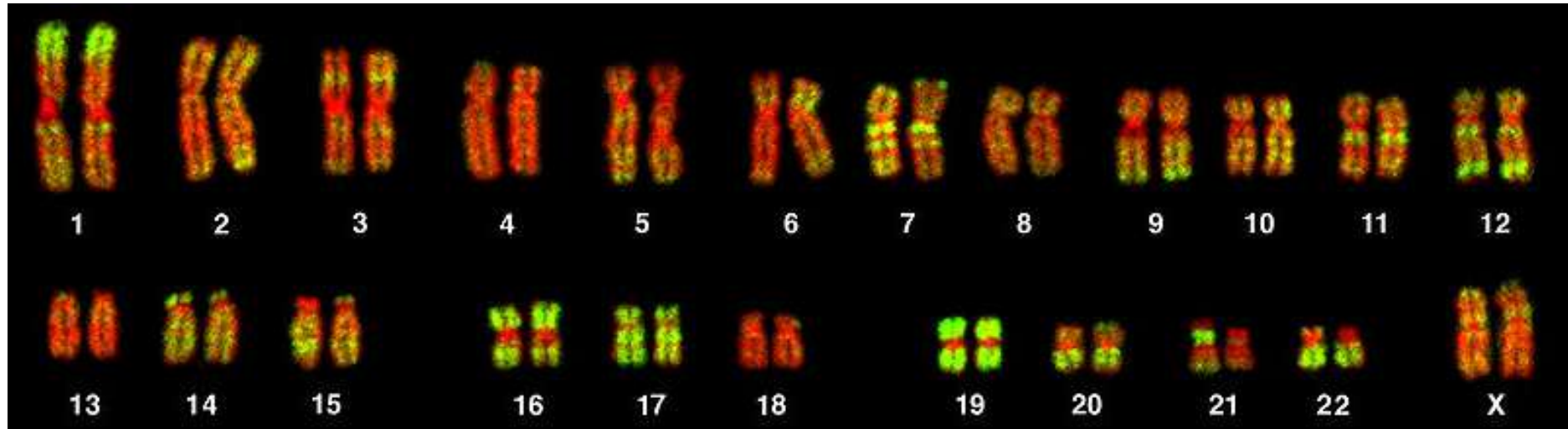

- *Homologous chromosomes: there are two copies of each chromosome; same size, same shape, same genes
- Each pair is known as homologous chromosomes p. 73NB

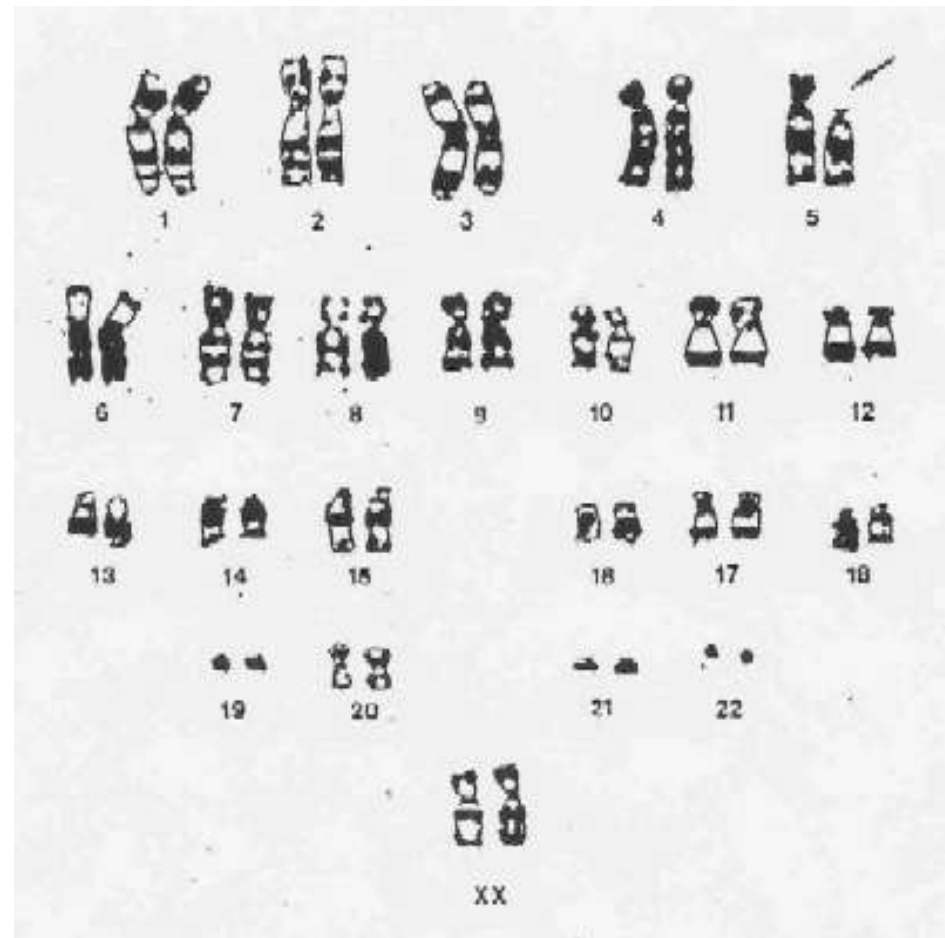

Draw this Diagram P. 73NB

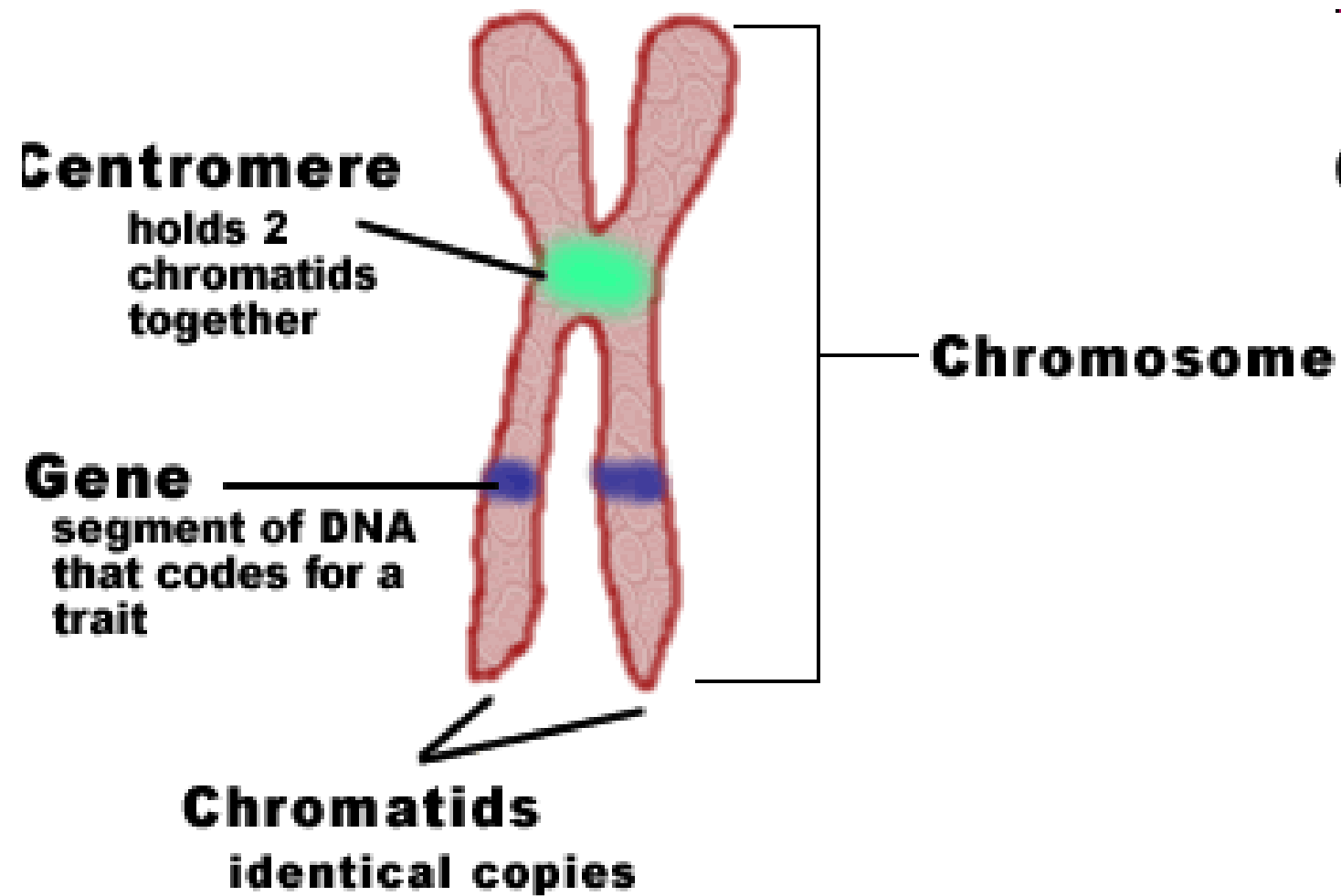

Actual Stained Chromosome



Klinefelter's Syndrome - XXY

- A condition in which males have an extra X sex chromosome
- the most common sex chromosome disorder
- the second most common condition caused by the presence of extra chromosomes.
- 1 out of every 1000 males.
- 1 out of every 500 has an extra X chromosome but does not have the syndrome
- Symptoms: almost always infertile, smaller testicles, some neurophysiological deficits, long lanky build, more severe cases have breast tissue and osteoporosis
- Treatment: usually just testosterone

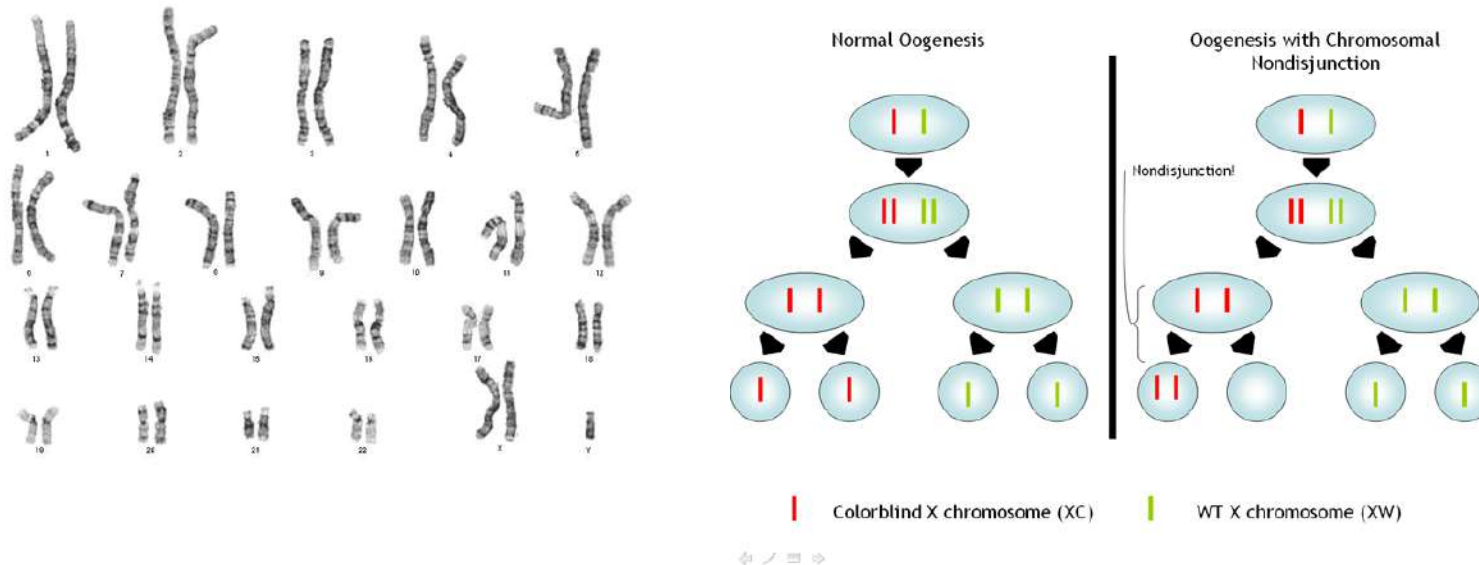

Turner Syndrome

- When a female is missing all or part of one of the X chromosomes (X0)
- 1 out of every 2500 girls are affected
- Symptoms: short stature, swelling broad chest, low hairline, low set ears, webbed necks, gonadal dysfunction, sterility
- High risk of: congenital heart disease, diabetes, vision problems, hearing problems



Patau's Syndrome

- also known as **trisomy 13**, a syndrome in which a patient has an additional chromosome 13 due to a nondisjunction of chromosomes during meiosis.
- Affects 1 in 25,000 live births; risk increases with age of female pregnancy
- Causes heart and kidney defects, mental and motor challenged, extra digits, low set ears, structural eye defects, abnormal genitalia

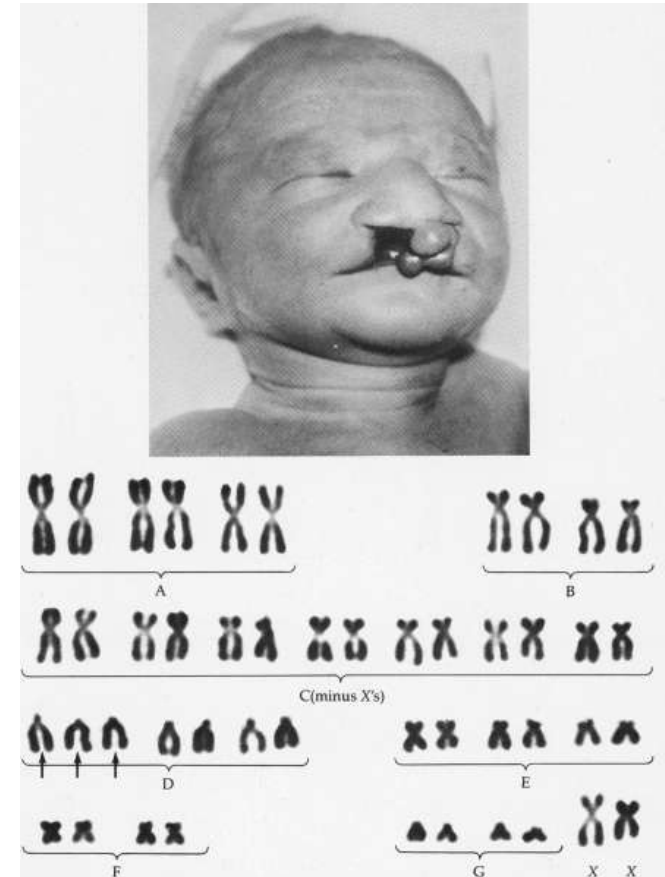

XYY Syndrome

- Most often, the extra Y chromosome causes no unusual physical features or medical problems.
- boys have an increased growth velocity during earliest childhood, with an average final height approximately 7 cm above expected final height.
- 1 in 1000 boys affected
- Increased learning disabilities, delayed speech/language skills, behavioral problems such as anger/agression

Down's Syndrome

- **Down's syndrome** AKA **trisomy 21**, or **trisomy G** is a chromosomal disorder caused by the presence of all or part of an extra 21st chromosome.
- 1 out of 1000 births are affected
- Small chin, round face, oversized tongue, shorter limbs, poor muscle tone, ear infections, heart defects,

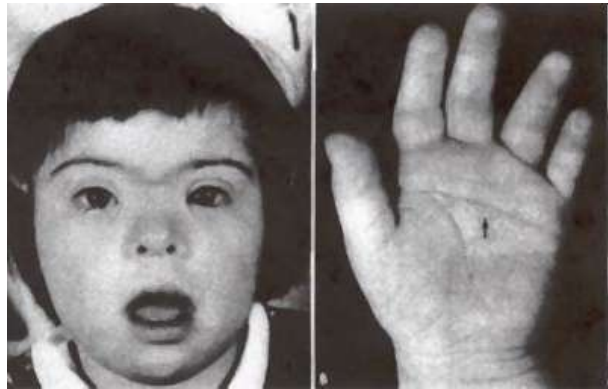

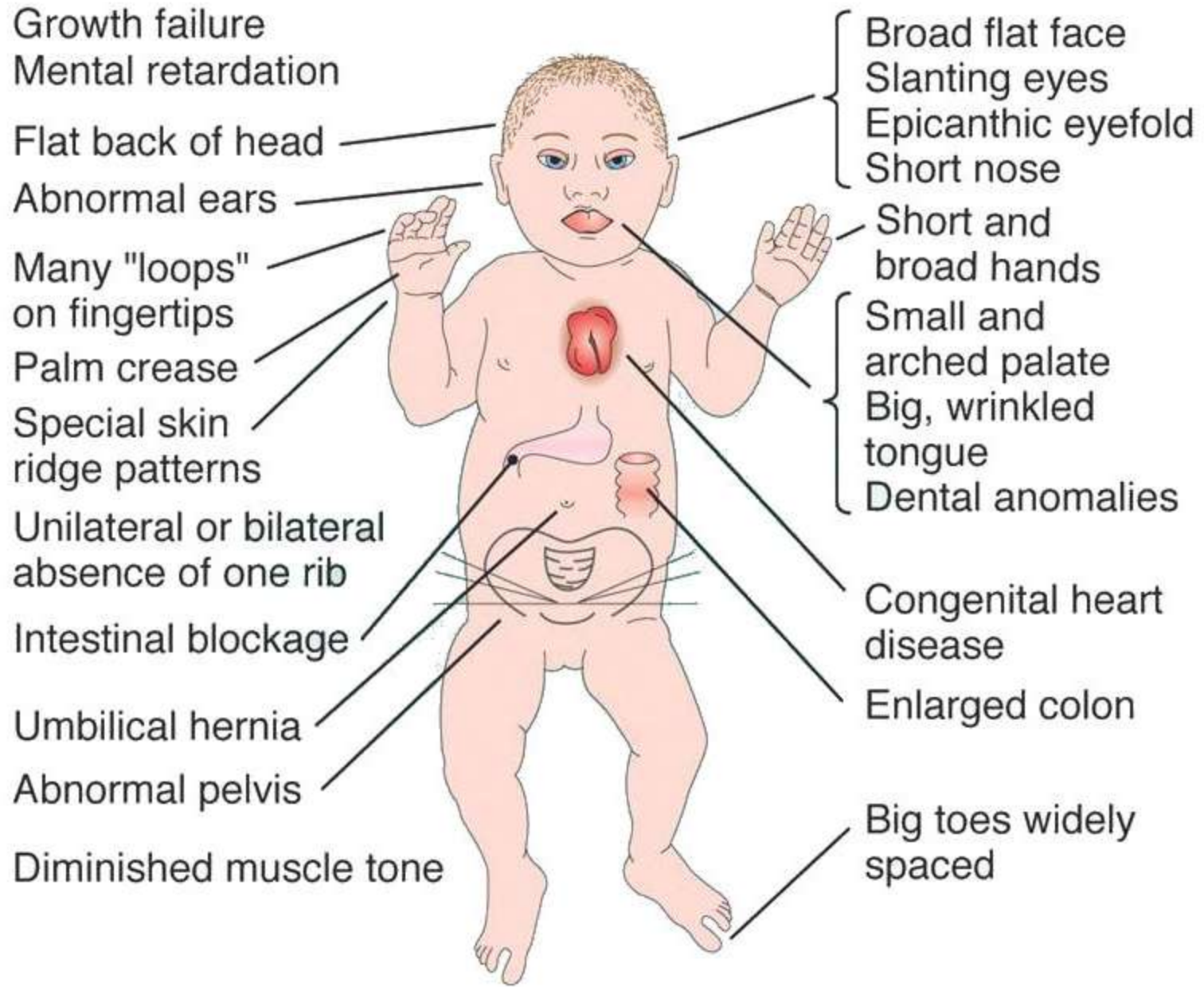

Triple X Syndrome

- a form of chromosomal variation characterized by the presence of an extra X chromosome in each cell of a human female.
- 1 in 1000 births
- only one X chromosome is active at any time in a female cell. Thus, triple X syndrome most often causes no unusual physical features or medical problems.
- Females with the condition may have menstrual irregularities, and, have an increased risk of learning disabilities, delayed speech, deficient language skills, and delayed development of motor skills.

Question 1

The passing on of characteristics from parents to offspring is _____.

- A. genetics
- B. heredity
- C. pollination
- D. allelic frequency

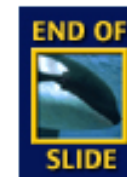

Question 2

What are traits?

Answer

Traits are characteristics that are inherited. Height, hair color and eye color are examples of traits in humans.

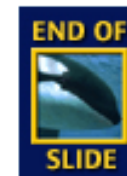

Question 3

Gametes are _____.

- A. male sex cells
- B. female sex cells
- C. both male and female sex cells
- D. fertilized cells that develop into adult organisms

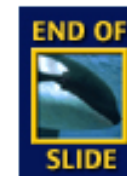

10.1

Section Check

The answer is C. Organisms that reproduce sexually produce male and female sex cells, called gametes.

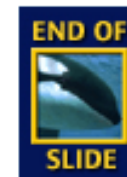

CA: Biology/Life Sciences
2a



10.1

Mendel's Laws of Heredity

Phenotypes (How it looks) and Genotypes (Letters that represent the trait)

Law of segregation $Tt \times Tt$ cross

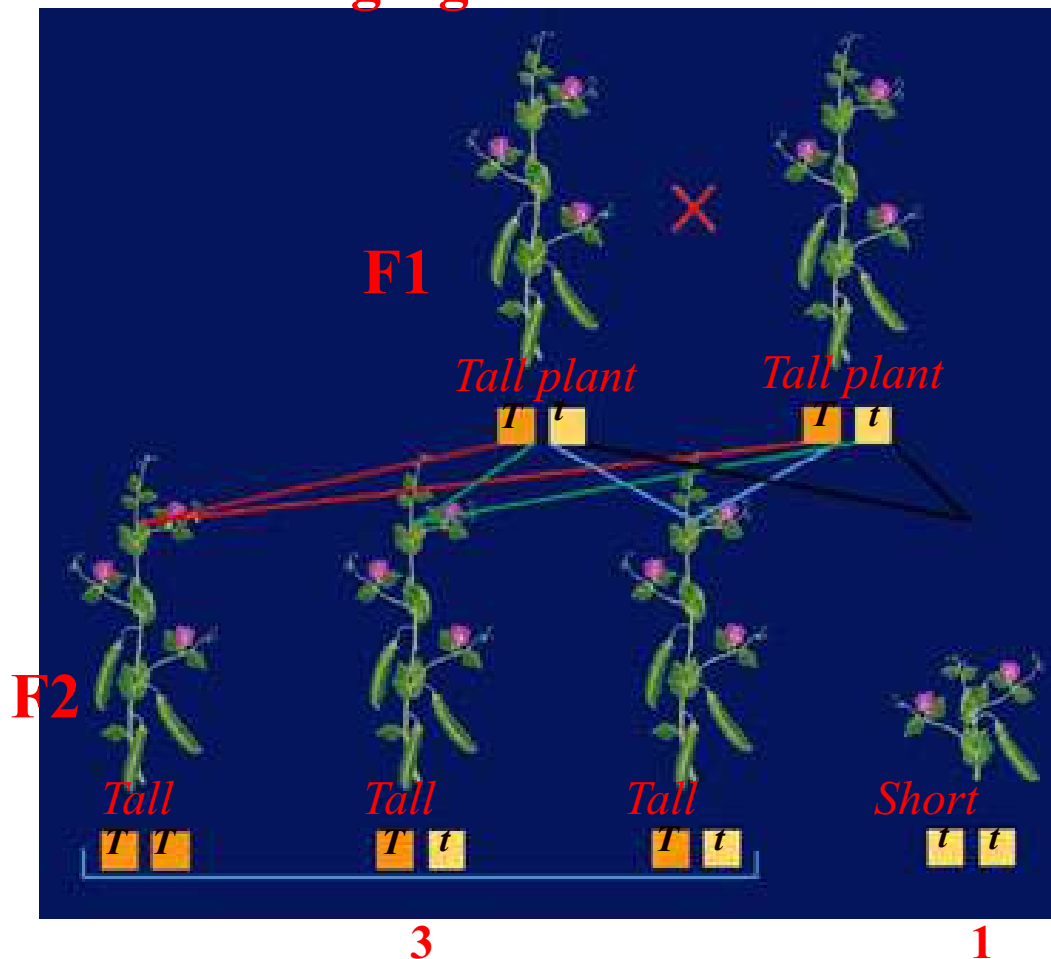

Two organisms can look alike but have different underlying allele combinations.

Tall – Phenotype
 TT , Tt – Genotype

Short – Phenotype
 tt - Genotype



Phenotypes and Genotypes

The way an organism looks and behaves is called its **phenotype**. Ex. Tall, Round, Brown Hair, wrinkled

The allele combination an organism contains is known as its **genotype**. Ex. TT, Rr, Bb, rr

An organism's genotype can't always be known by its phenotype.



RESOURCES

STEP 1

Fold one piece of paper lengthwise into thirds.

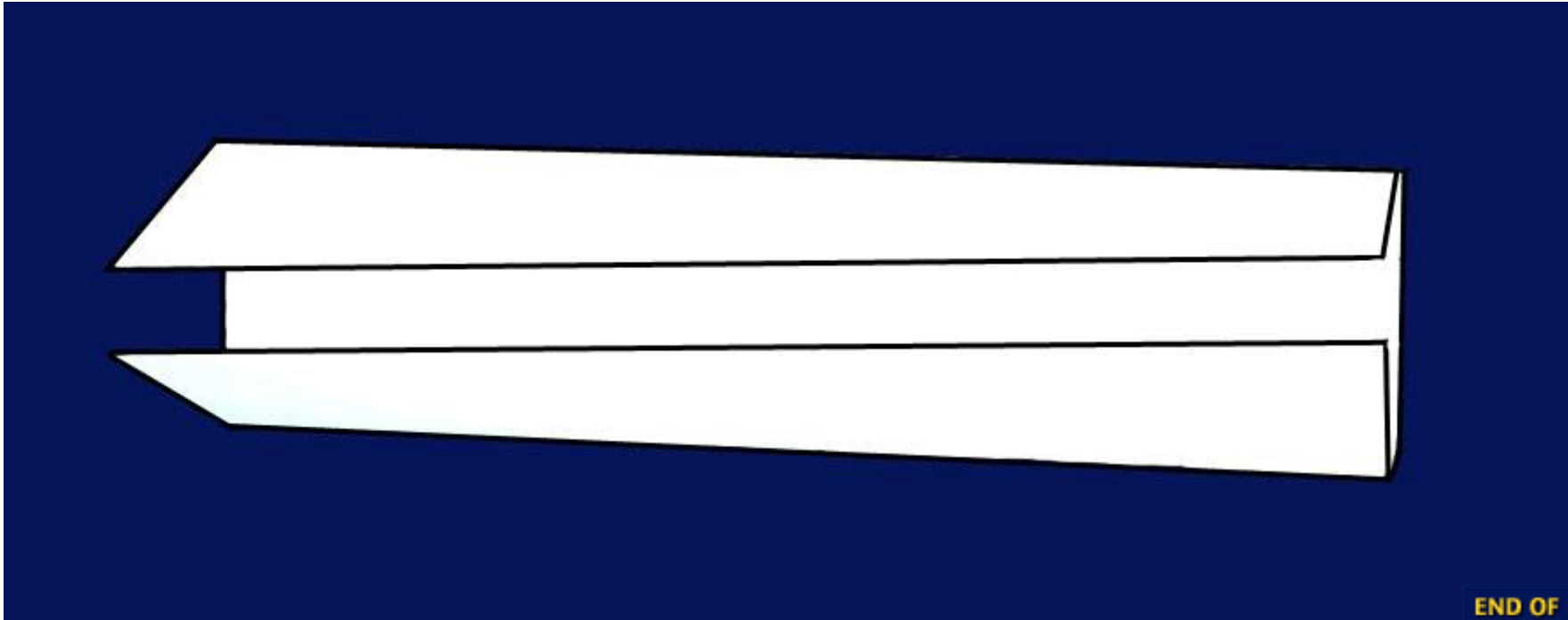

To return to the chapter summary click escape or close this document.



STEP 2

Fold the paper widthwise into fifths.

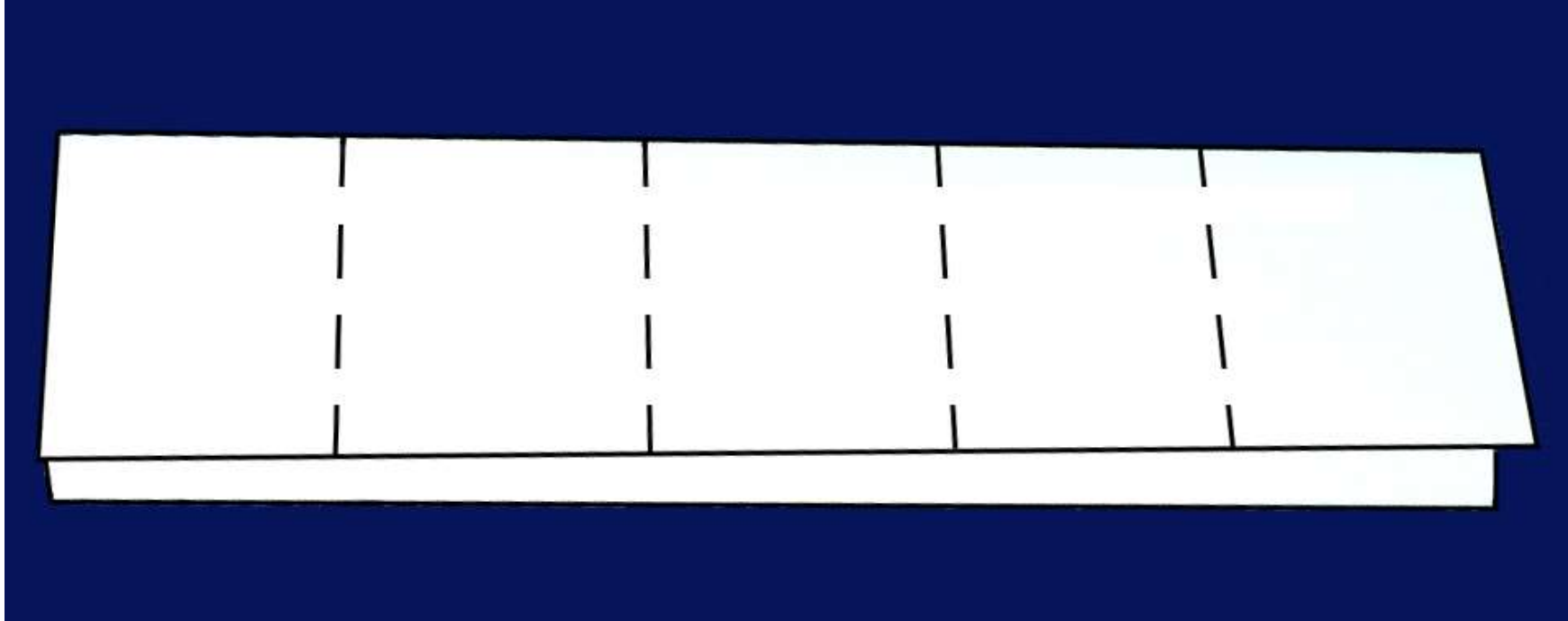

END OF
SLIDE

To return to the chapter summary click escape or close this document.



RESOURCES

STEP 3

Unfold, lay the paper lengthwise, and draw lines along the folds.

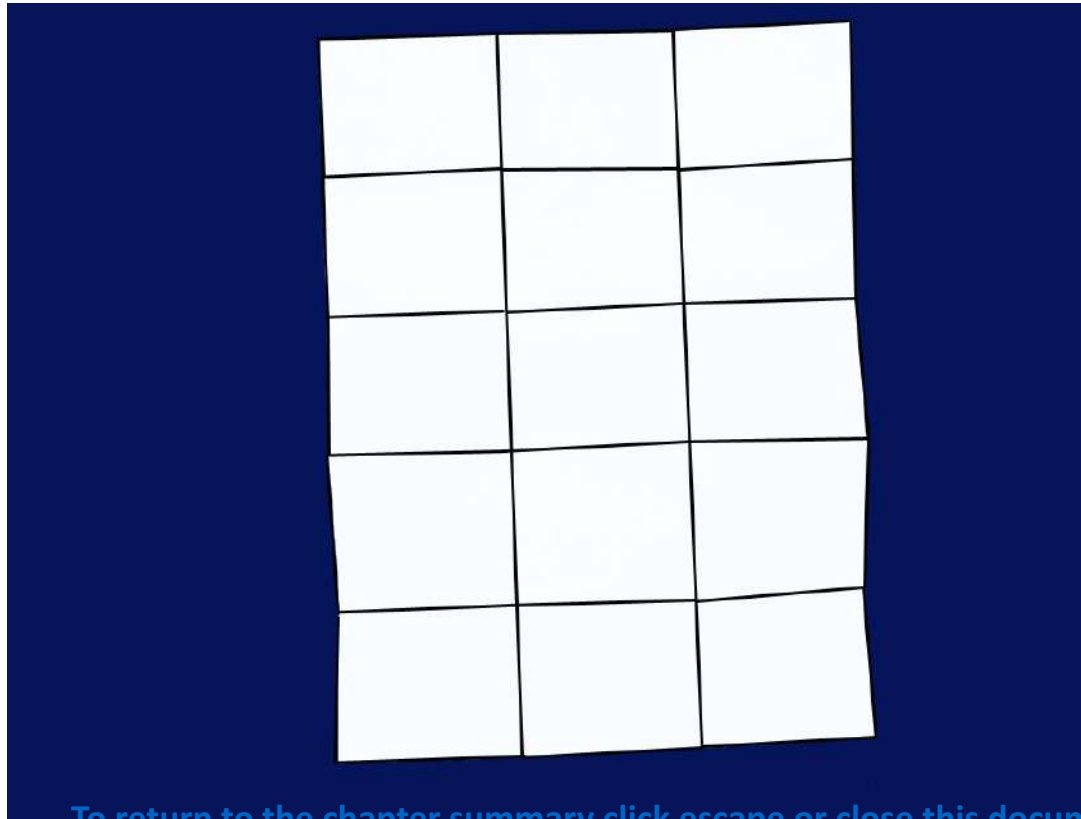

To return to the chapter summary click escape or close this document.

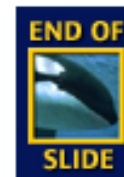

STEP 4

Label your table as shown.

Mendel	Describe in Your Words	Give an Example
Rule of unit factors Allele		
Rule of Dominance		
Law of Segregation		
Law of independent assortment		

To return to the chapter summary click escape or close this document.

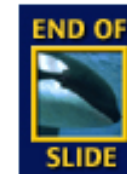

Chromosomes & Inheritance p. 13NB

- Do to <http://learn.genetics.utah.edu/>
- Click on chromosomes & Inheritance
- Click on Make a Karyotype **Write the sex of the offspring & how you know.**
- Click on Using Kayotypes to detect genetic disorders.
- After reading the page, **write a summary that includes Homologous Chromosome, Autosomes, Sex Chromosomes, and Karyotype.**
- **How can Karyotypes be used to diagnose genetic disorders?**

The law of segregation

1. **The law of segregation** states that every individual has two alleles of each gene and when gametes (eggs & sperm) are produced, each gamete receives one of these alleles.

During fertilization, these gametes randomly pair to produce four combinations of alleles.

Each gamete receives one allele.

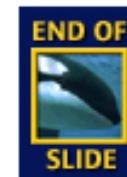

The law of independent assortment

2. Mendel's second law states that genes for different traits—for example, seed shape and seed color—are inherited independently of each other.

This conclusion is known as the **law of independent assortment**.

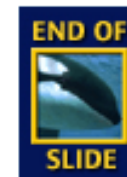
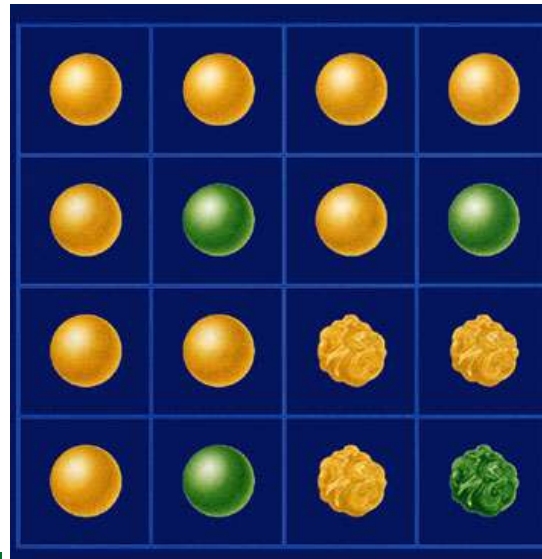

Phenotypes and Genotypes

An organism is **homozygous** for a trait if its two alleles for the trait are the same. **RR,ss, HH**



The **true-breeding** tall plant that had two alleles for tallness (*TT*) would be homozygous for the trait of height.

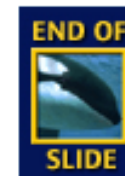

Phenotypes and Genotypes

An organism is **heterozygous** for a trait if its two alleles for the trait differ from each other. **Tt**, **Ss**,

XY
Therefore, the tall plant that had one allele for tallness and one allele for shortness (**Tt**) is heterozygous for the trait of height.

Hybrid - Mm

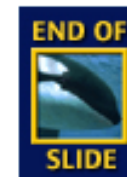

Monohybrid crosses

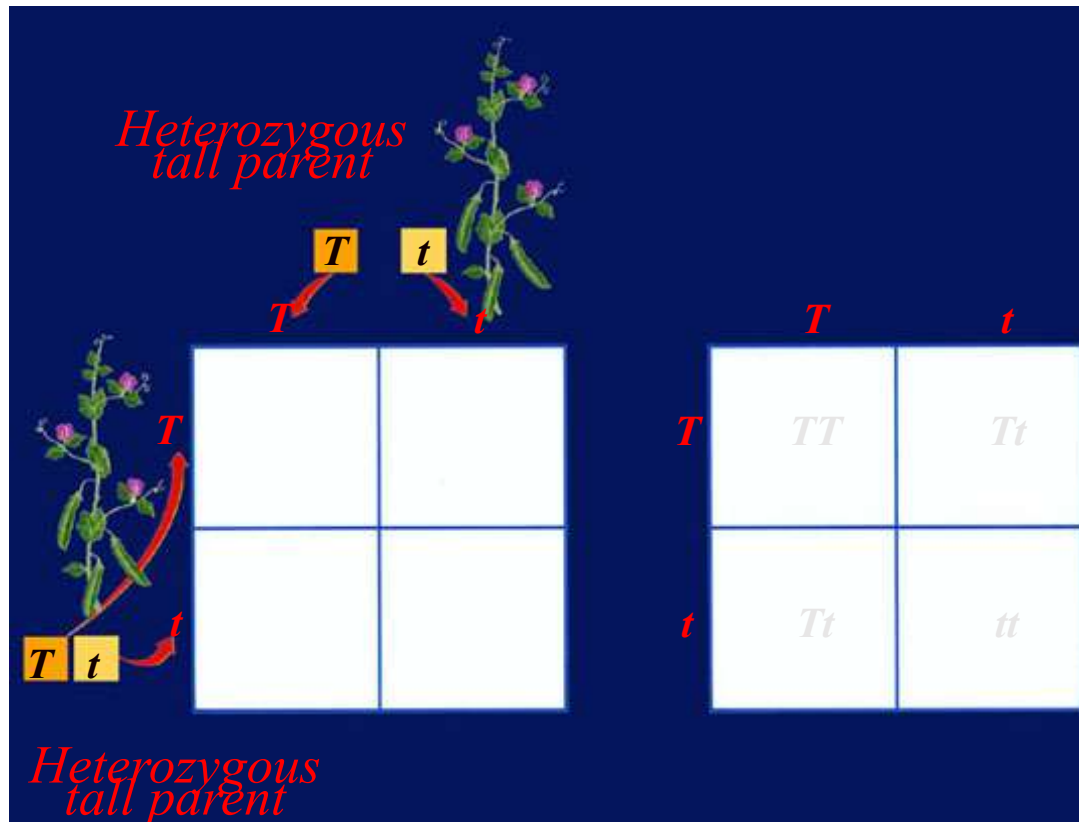

A Punnett square for this cross is two boxes tall and two boxes wide because each parent can produce two kinds of gametes for this trait.

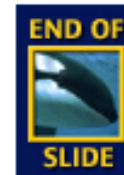

RESOURCES

Probability

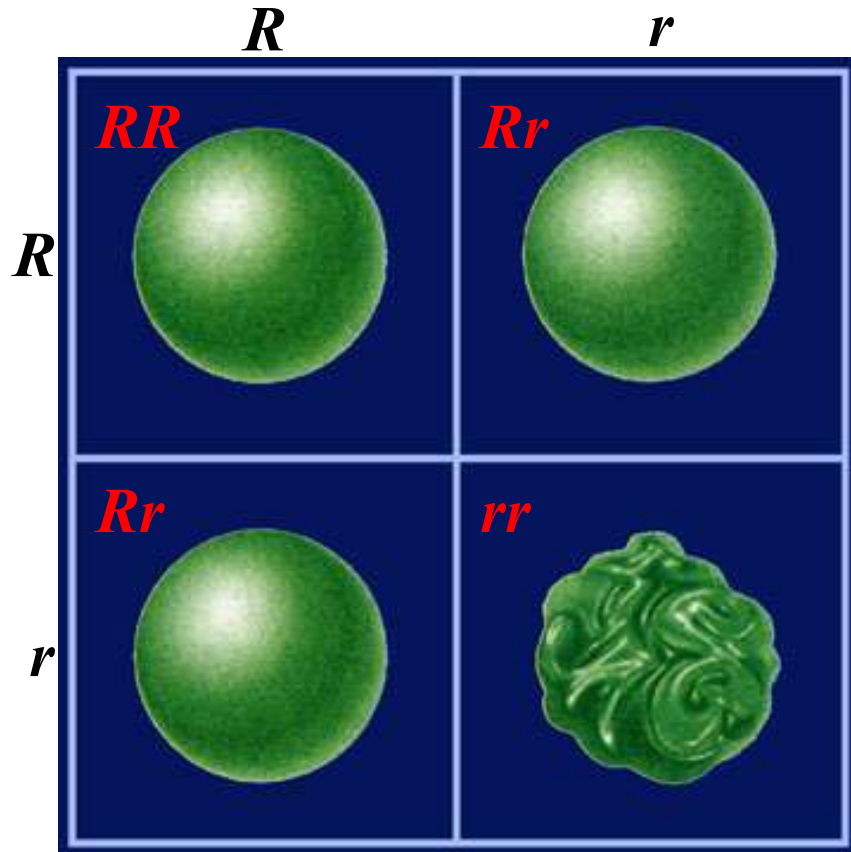

The Punnett square shows three plants with round seeds out of four total plants, so the probability is $\frac{3}{4}$.

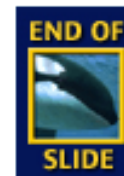
[RESOURCES](#)















Chapter 10

Complete Dominance

– the Dominant completely masks the recessive, only 2 versions of a trait.

Mendel's Seven Pea Traits

What would be appropriate alleles to use for each trait?

	Seed shape	Seed color	Flower color	Flower position	Pod color	Pod shape	Plant height
Dominant trait	 round	 yellow	 purple	 axial (side)	 green	 inflated	 tall
Recessive trait	 wrinkled	 green	 white	 terminal (tips)	 yellow	 constricted	 short



To return to the chapter summary click escape or close this document.



Punnett Square Practice Activity

p.265 Biology Book

- Make 7 Punnett square boxes on P.13 NB
- Choose different genotypes for each of the different Pea Traits and perform Punnett square crosses with different combinations of genotypes.
- Write to the side the % probability of the Homozygous Recessive, Heterozygous, Homozygous Dominant

10.1

Mendel's Laws of Heredity

The first generation







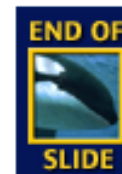
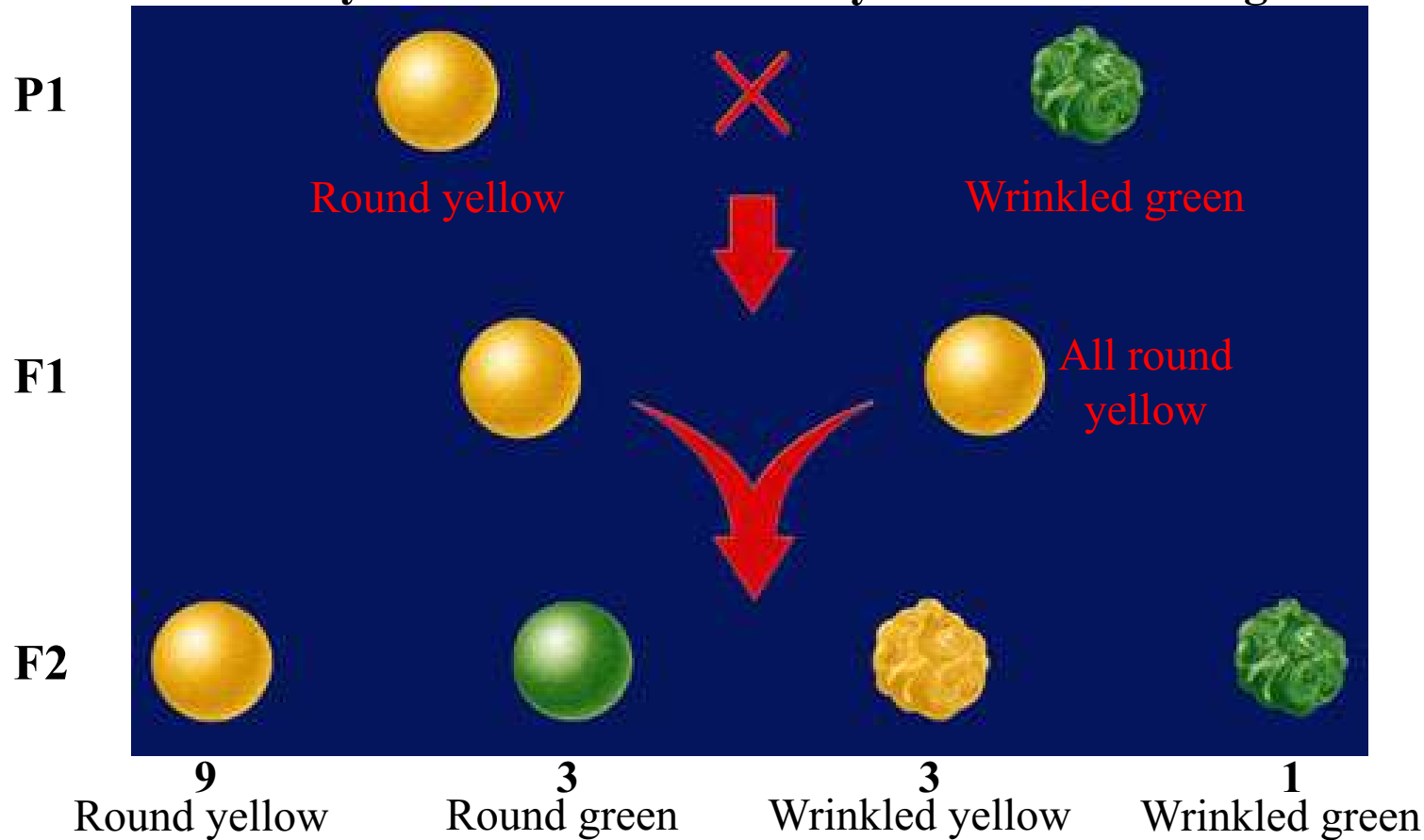











Dihybrid Cross

round yellow x wrinkled green



Punnett Square of Dihybrid Cross

Gametes from *RrYy* parent

		<i>RY</i>	<i>Ry</i>	<i>rY</i>	<i>ry</i>
<i>RrYy</i> parent	<i>RY</i>	<i>RRYY</i> 	<i>RRYy</i> 	<i>RrYY</i> 	<i>RrYy</i> 
	<i>Ry</i>	<i>RRYy</i> 	<i>RRyy</i> 	<i>RrYy</i> 	<i>Rryy</i> 
	<i>rY</i>	<i>RrYY</i> 	<i>RrYy</i> 	<i>rrYY</i> 	<i>rrYy</i> 
	<i>ry</i>	<i>RrYy</i> 	<i>Rryy</i> 	<i>rrYy</i> 	<i>rryy</i> 





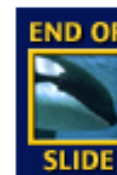











Dihybrid crosses

A Punnett square for a dihybrid cross will need to be four boxes on each side for a total of 16 boxes.

[RESOURCES](#)

Punnett Square of Dihybrid Cross

Gametes from *RrYy* parent

		<i>RY</i>	<i>Ry</i>	<i>rY</i>	<i>ry</i>
<i>RrYy</i> parent	<i>RY</i>	<i>RRYY</i> 	<i>RRYy</i> 	<i>RrYY</i> 	<i>RrYy</i> 
	<i>Ry</i>	<i>RRYy</i> 	<i>RRyy</i> 	<i>RrYy</i> 	<i>Rryy</i> 
	<i>rY</i>	<i>RrYY</i> 	<i>RrYy</i> 	<i>rrYY</i> 	<i>rrYy</i> 
	<i>ry</i>	<i>RrYy</i> 	<i>Rryy</i> 	<i>rrYy</i> 	<i>rryy</i> 



Dihybrid crosses

F1 cross: *RrYy* × *RrYy*

	round yellow
	round green
	wrinkled yellow
	wrinkled green

END OF



SLIDE



RESOURCES

10.1

Dihybrid Cross

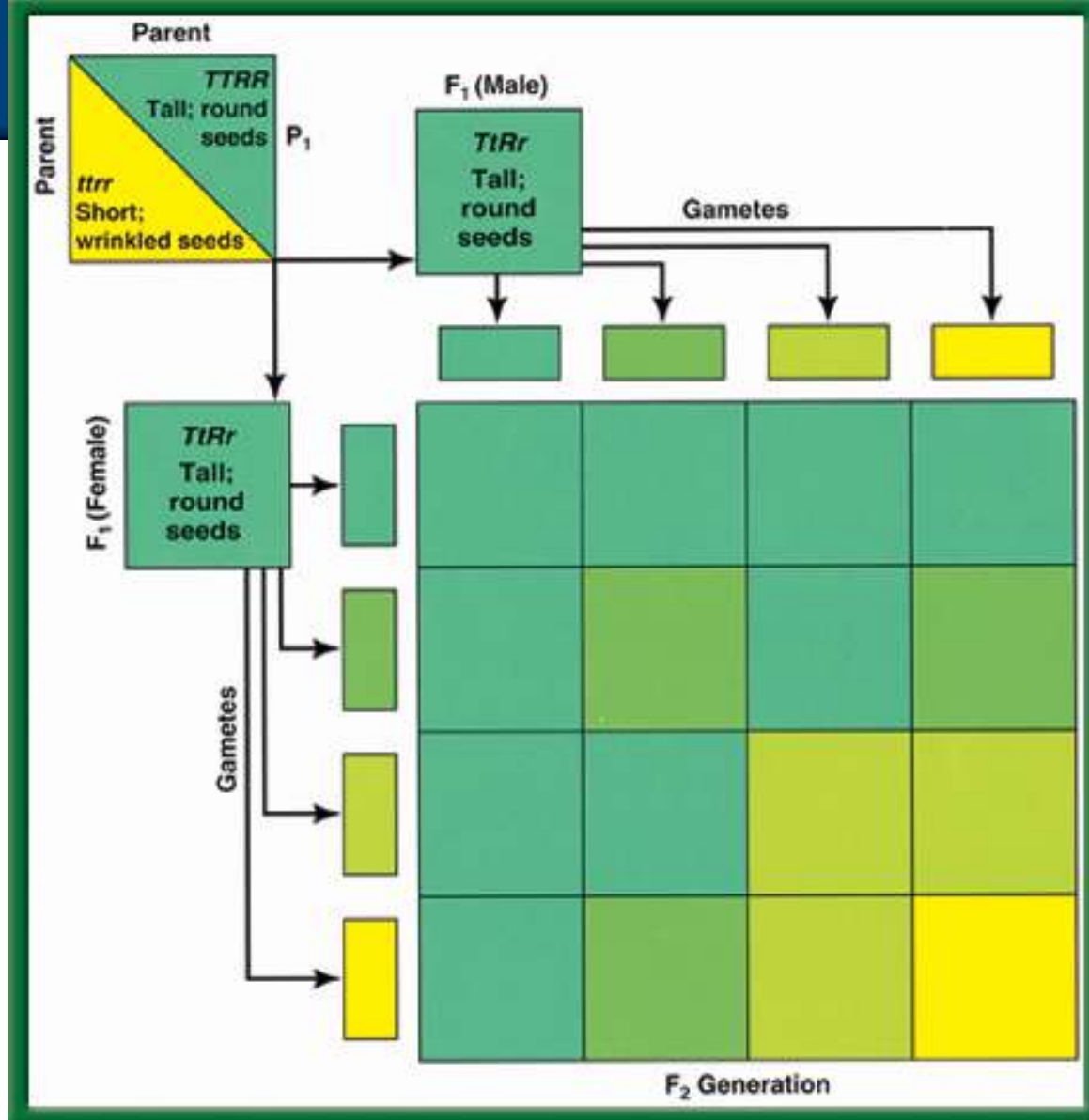

P. 17 NB

Use $\frac{3}{4}$ of paper, $\frac{1}{4}$ to write an AXES paragraph
Law of Independent Assortment

Meiosis Activity with beads.

Simulate the process of Meiosis with a partner.

Show us your simulation.

Explain in your notebook page 15

How does Meiosis add genetic variation to the population? Use these words: gamete, sex cell, haploid, homologous chromosomes, division, egg or sperm cell.

- Mitosis vs. [Meiosis](#) video demonstration

Genetic Inheritance Quiz

1. Draw a Chromosome and label a trait.
2. Draw a Punnett Square
3. Write the genotype XX for Mom
4. Write the genotype XY for Dad
5. Complete the Punnett square
6. What is the Probability of having a girl?
7. Write the gamete for mom
8. Write the gamete for dad
9. Explain what a zygote is, draw a picture if you need to.
10. Examine the Karyotype above, Is it a girl or a boy, How do you know?

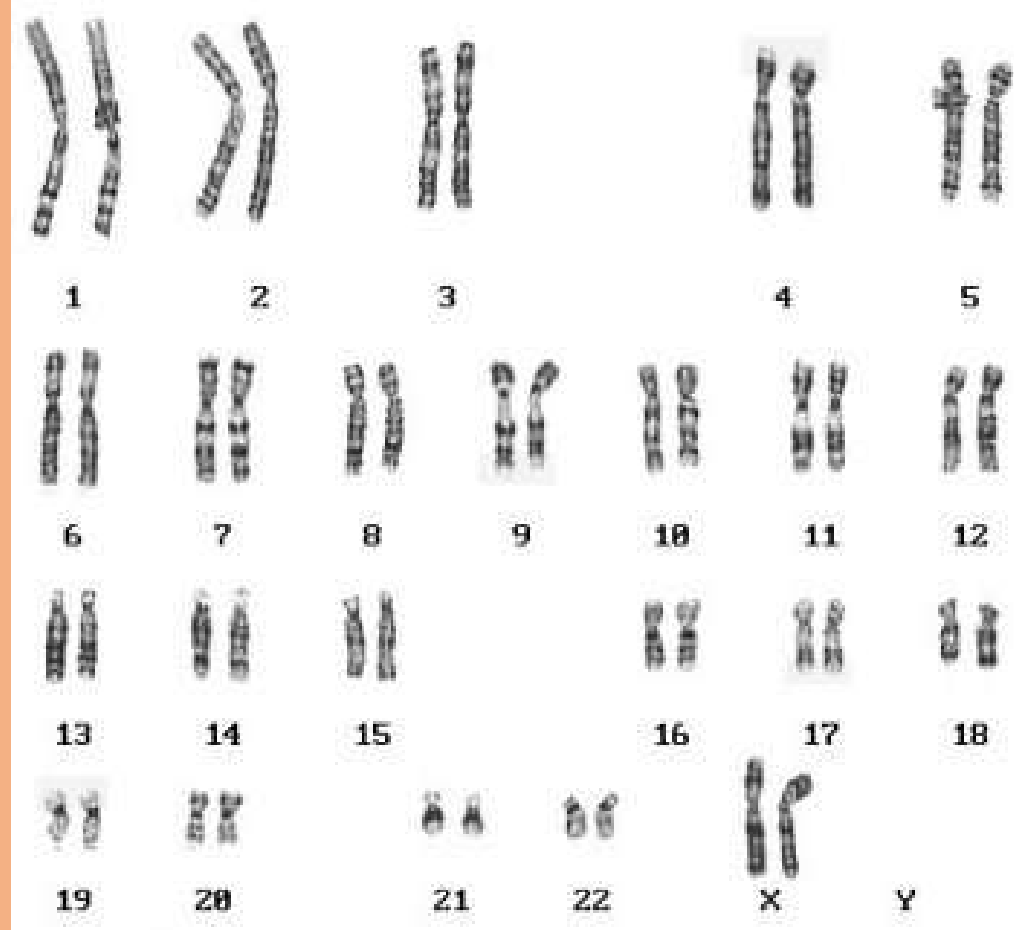

Homozygous and Heterozygous

1. Homozygous: when identical alleles of the gene are present on both chromosomes

- Said to be true breeding
- Homo means same
- Can be homozygous recessive (bb) or homozygous dominant (BB)
- **Heterozygous:** when two different alleles occupy the gene's position on the chromosomes
 - Heterozygous: Bb

2. Crossing Over adds **genetic variation** to the species. It is an example of Genetic Recombination and happens during Prophase 1 of Meiosis.

3. Haploid Cells are the **gametes**, Egg & Sperm Cells. They have 1 set of chromosomes from mom or dad.

Diploid Cells are the **Body Cells**, heart, muscle cells. They have 2 sets of chromosomes from Mom & Dad.

Human Autosomal Genetic Disorders

Complete the concept map on human autosomal genetic disorders. Use these words or phrases one or more times: *Tay-Sachs disease, recessive allele, phenylketonuria, dominant allele, lungs and pancreas, central nervous system, cystic fibrosis.*

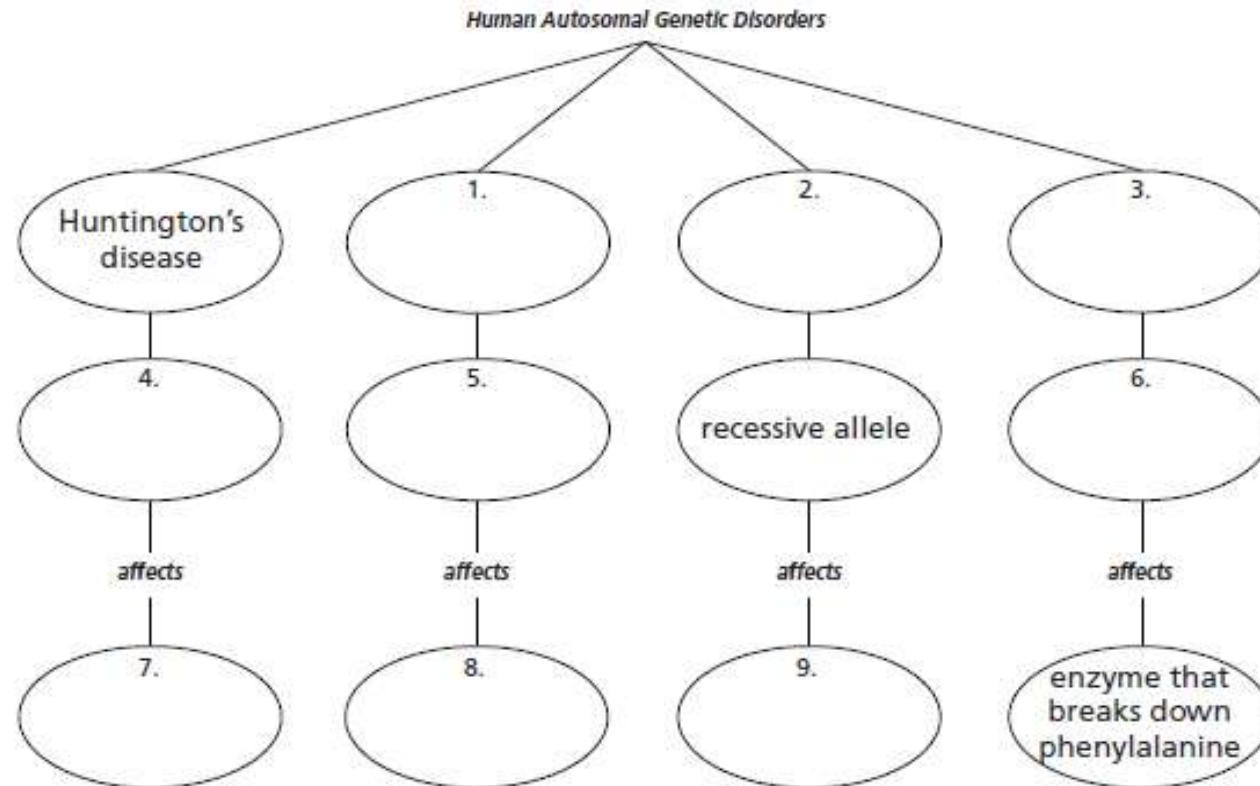

P. 81NB
4 Sentence
Summary

- Tay – Sachs Disease
- Recessive allele
- Phenylketonuria
- Dominant allele
- Lungs & pancreas
- Central Nervous System
- Cystic Fibrosis

Genetic Inheritance

Why are there different Blood
Types?

Week 12

10/31 Inheritance 12.2 & 12.3

Obj. TSW demonstrate understanding of Blood Types (multiple allelic), by performing punnett square crosses with probabilities. P.18 NB

<http://learn.genetics.utah.edu/>

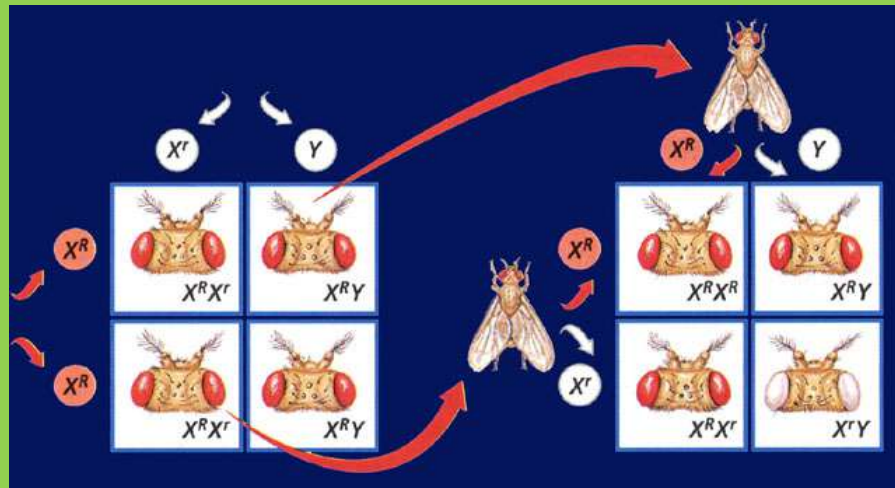
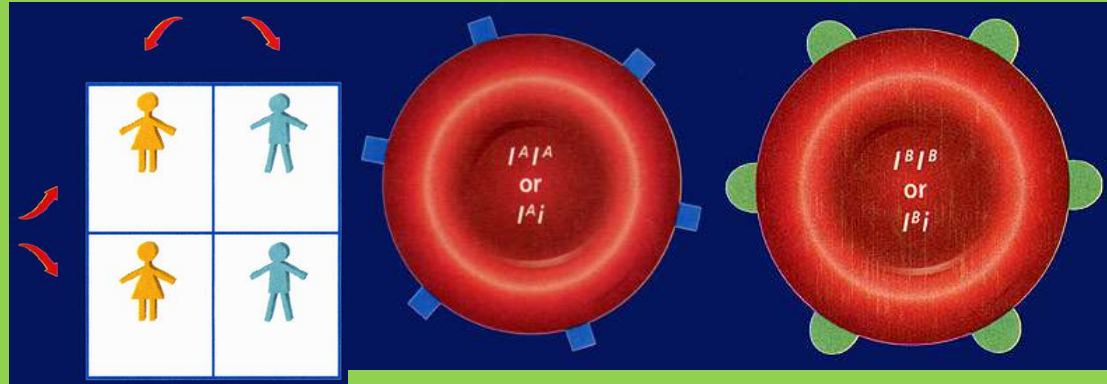

1. How is the sex of an offspring determined? Show the Punnett Square. What % will be male, what % will be female?
2. In sex-linked inheritance, which chromosome will the trait be expressed? How is it different from an autosome?
3. Perform a multiple allelic cross Punnett Square of the blood types: $I^A i$ x $I^B i$.

12.3

Complex Inheritance of Human Traits

Multiple Alleles Govern Blood Type Answers #1 & 2

Human Blood Types		
Genotypes	Surface Molecules	Phenotypes
$I^A I^A$ or $I^A i$	A	A
$I^B I^B$ or $I^B i$	B	B
$I^A I^B$	A and B	AB
ii	None	O



Question #3.

	I ^A	i
I ^B	I ^A I ^B	I ^B i
i	I ^A i	ii

Genotypes:

Phenotypes:

Probability of
A Blood?
B Blood?
AB Blood?
O Blood?

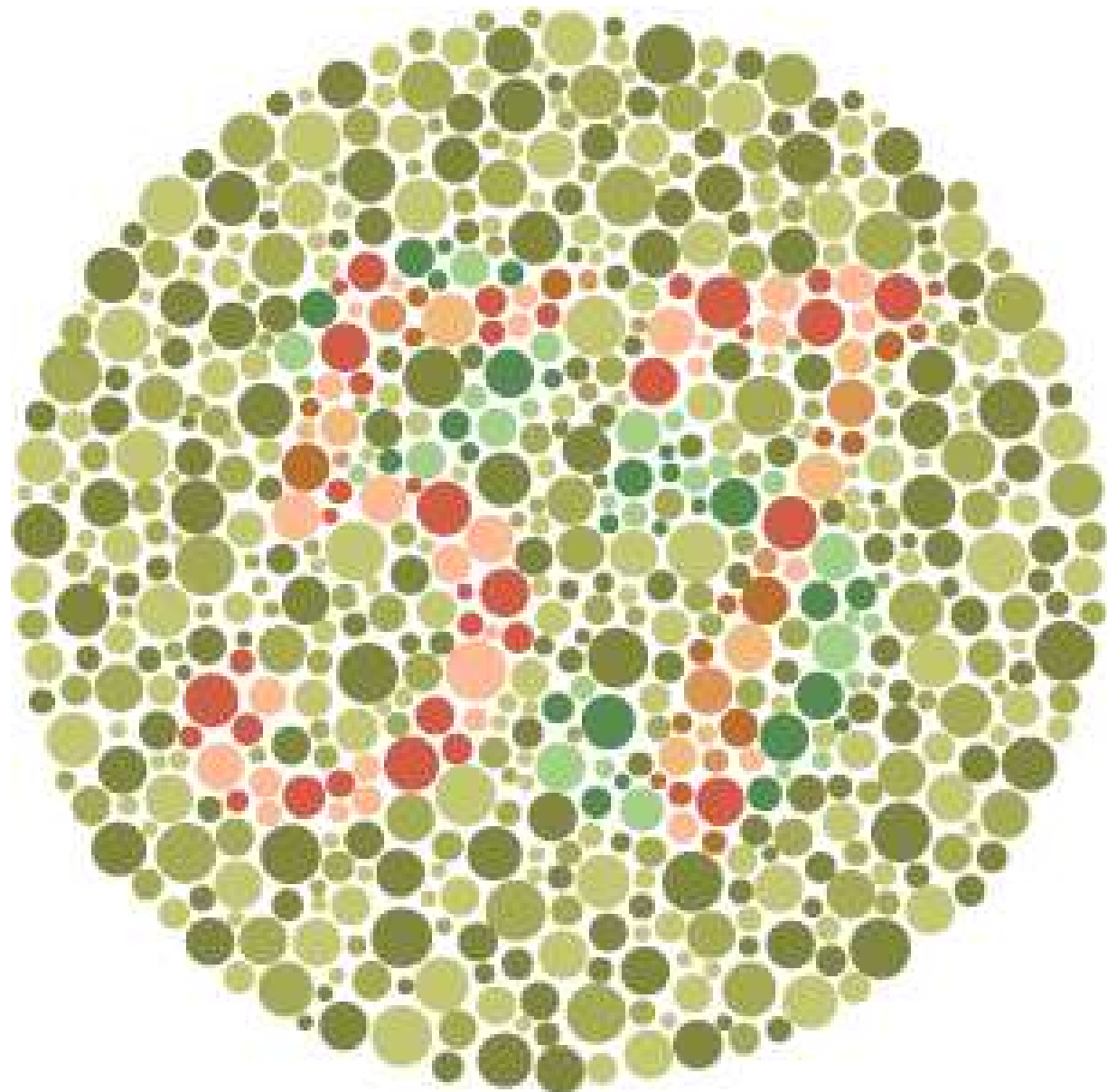

Mitosis vs Meiosis Notes P. 21 NB

Somatic Cell (Body Cell)

- Skin Cell
- 2N (Diploid)
- 46 Chromosomes
- 1 Division
- Produces 2 identical cells,
Same as the parent cell

Gametes (Sex Cells)

- Eggs & Sperm
- 2N -> 1N (Haploid)
- 23 Chromosomes
- 2 Divisions
- Produces 4 Haploid cells, all different from each other and the parent cells
- Increases Genetic Variation
 - Crossing Over
 - Independent Assortment
 - Random Fertilization

Classroom Family Pedigree

- Work by yourself, with a partner or two other people.
- Come up and get a Family Scenario of an Inherited Trait
- Draw a Rough Family Pedigree on Binder paper, with affected people shaded, carriers half shaded, and unaffected not shaded. Include all names.
- Include a Key showing all the possible combinations of the trait for each sex.
- What is the Disease/ Trait? Give a definition.
- Is the Disease/ Trait Dominant or Recessive?
- Is the trait Autosomal or Sex – Linked?
- Show all Genotypes

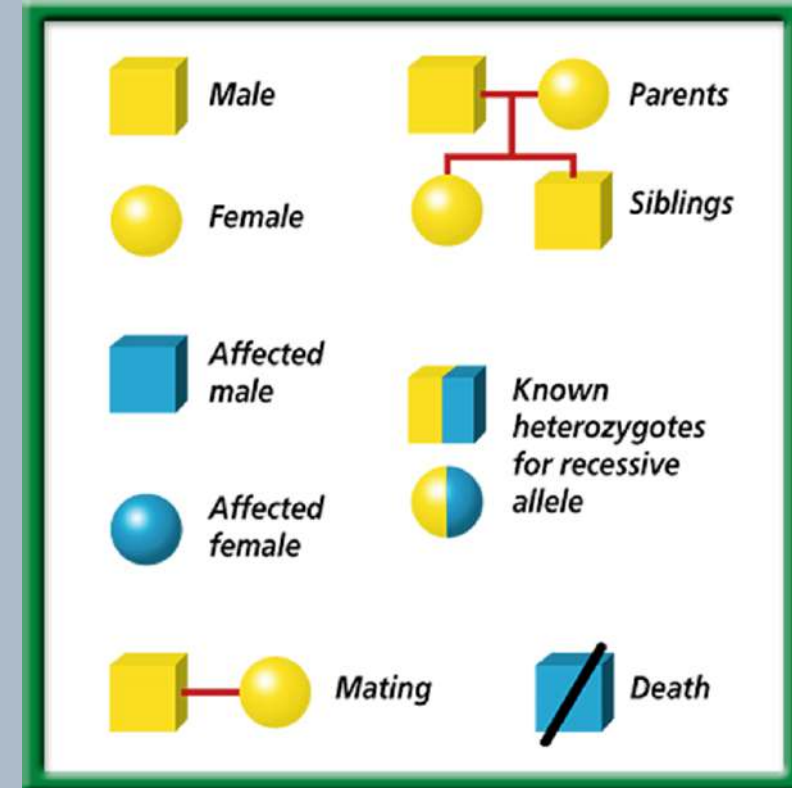

Symbols Used by Geneticists

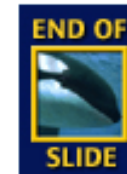
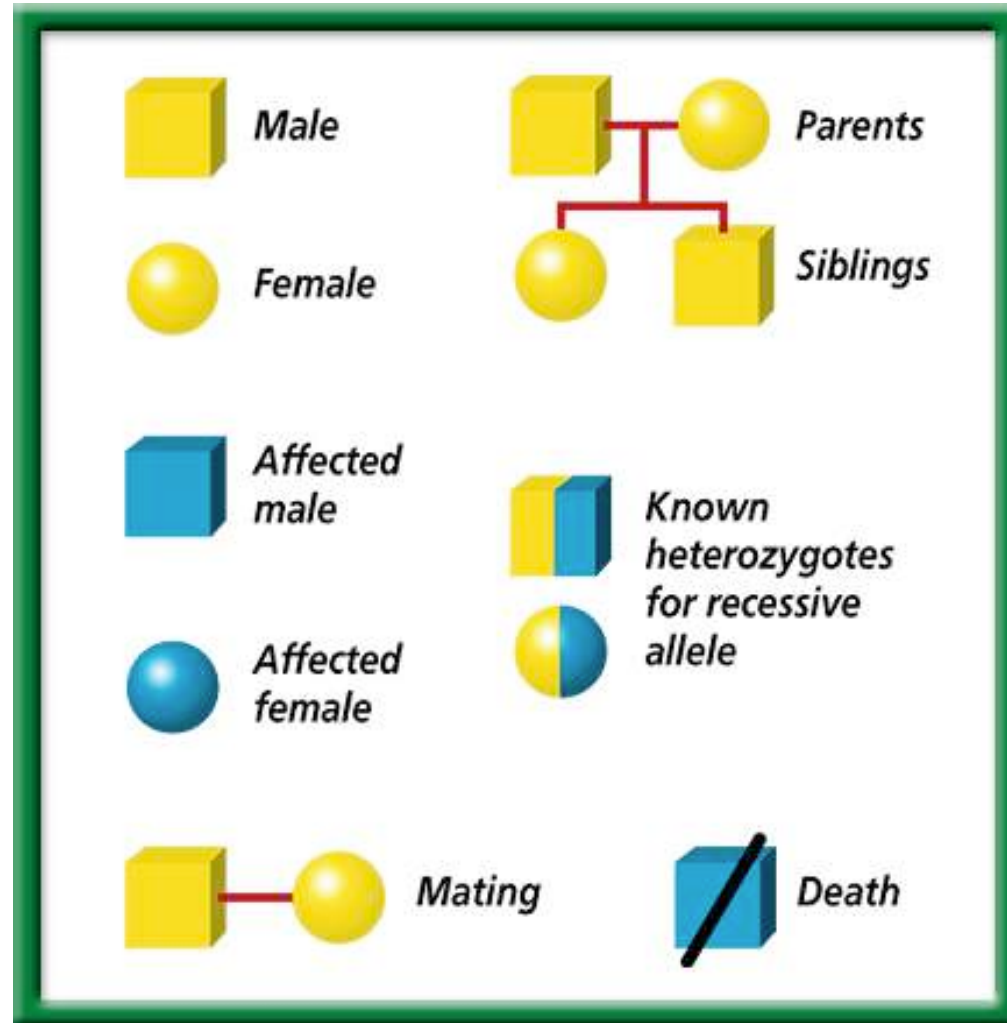

To return to the chapter summary click escape or close this document.



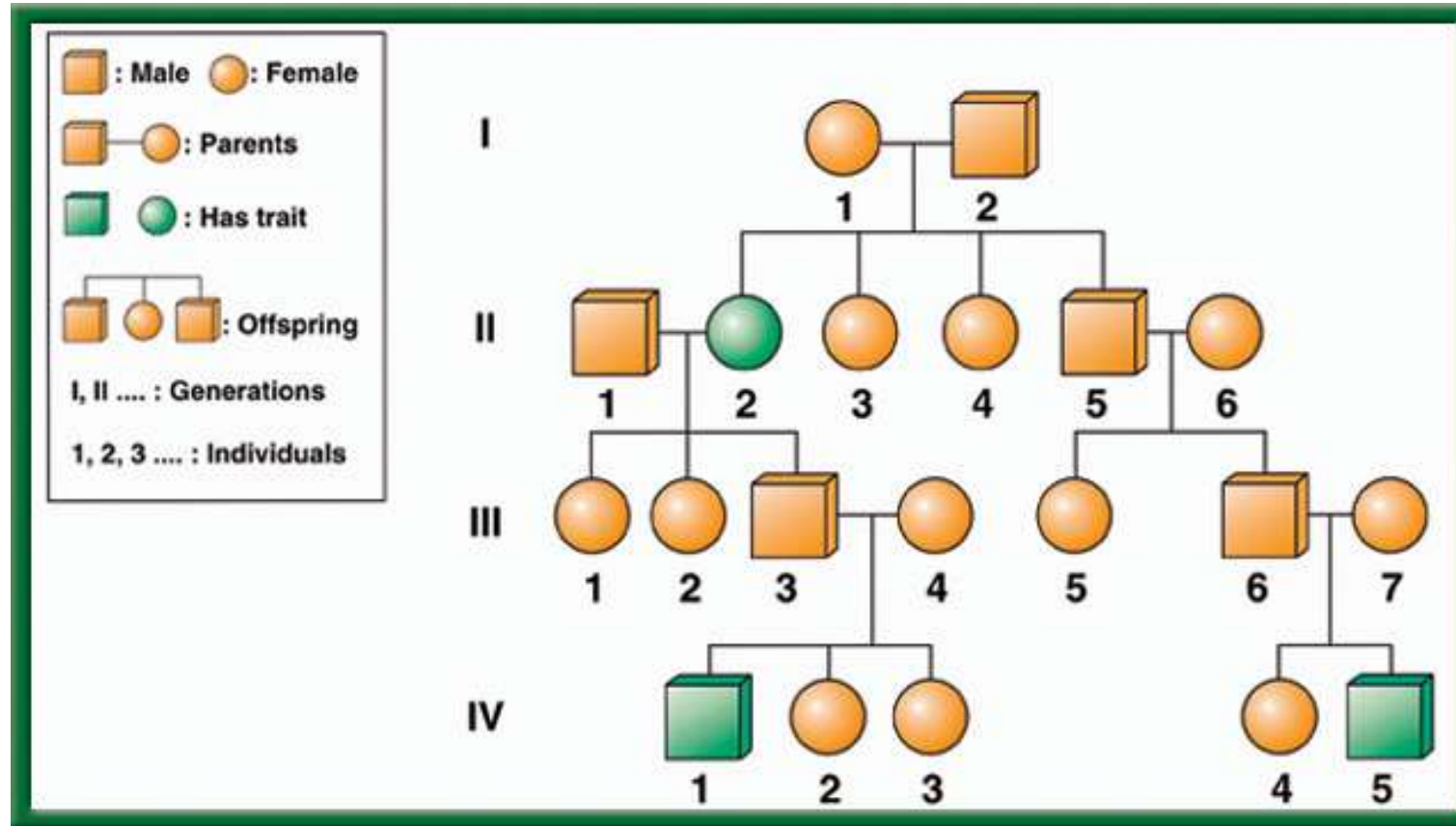

To return to the chapter summary click escape or close this document.



Simple Pedigree

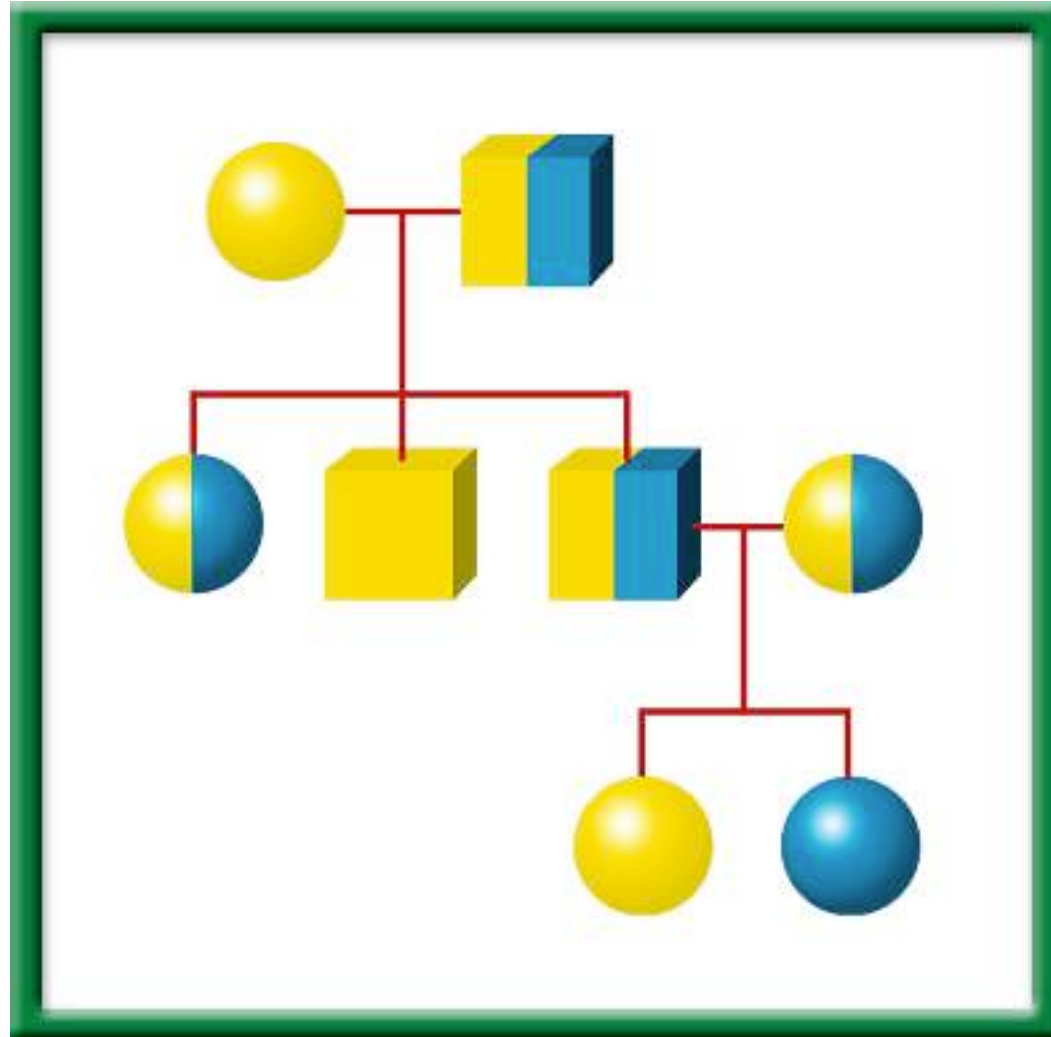

To return to the chapter summary click escape or close this document.



Fictional Pedigree

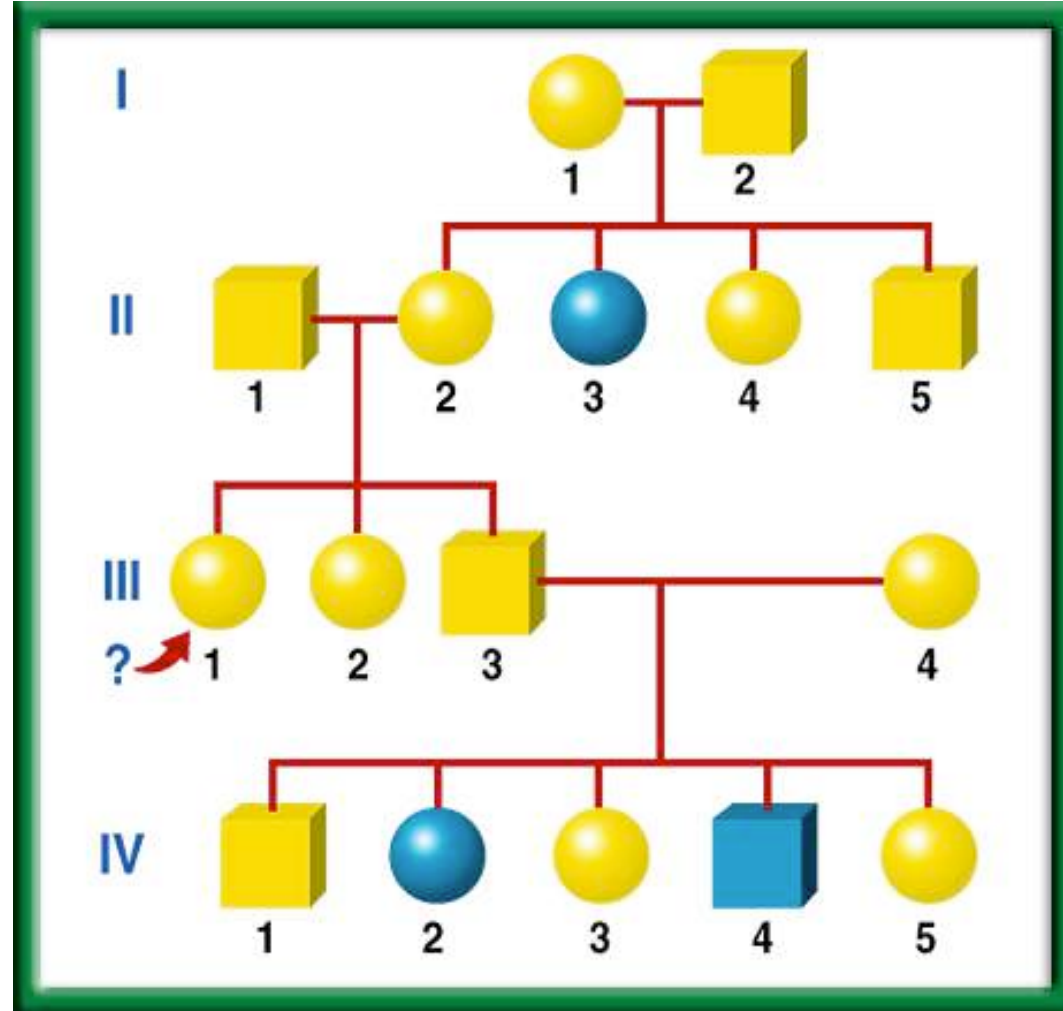

To return to the chapter summary click escape or close this document.

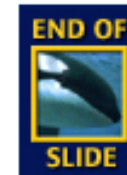

Pedigree- Huntington Disease

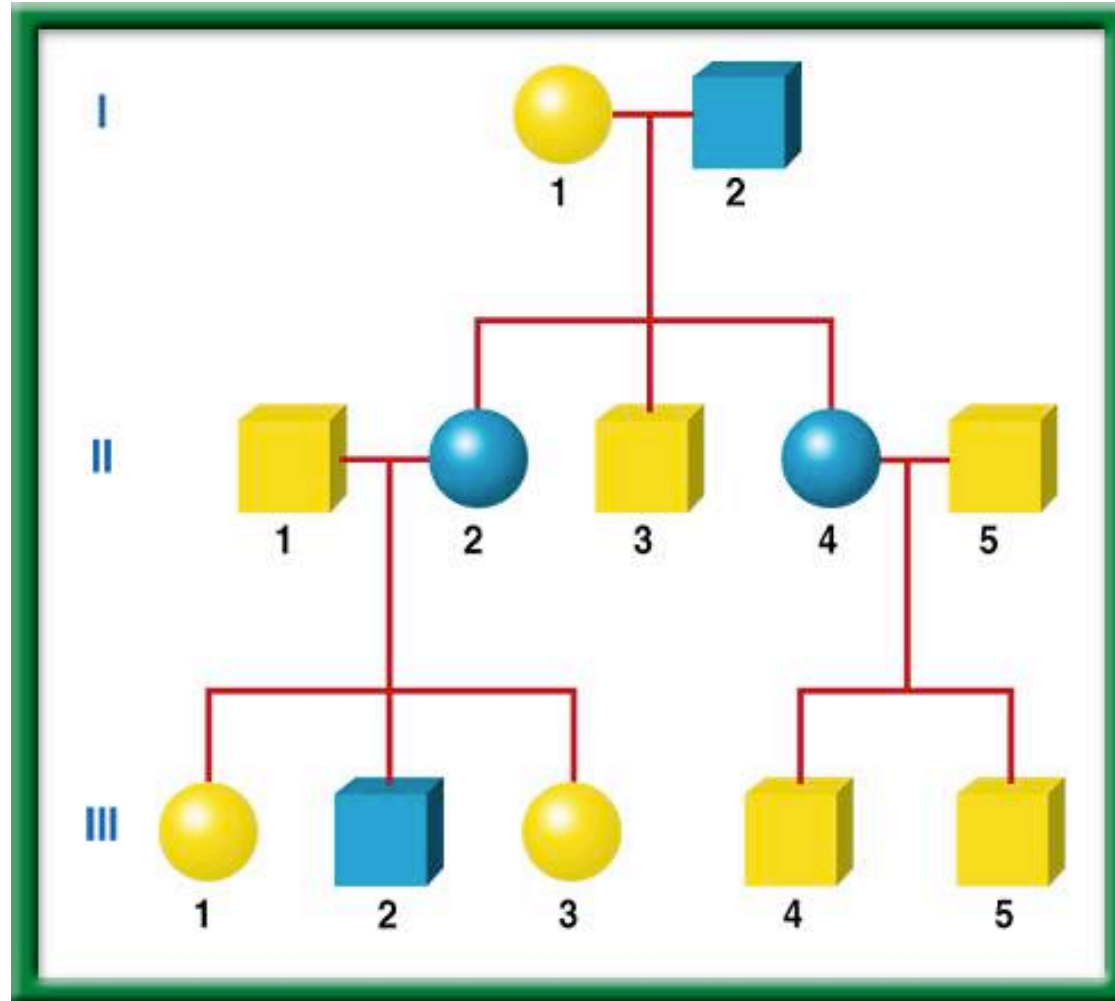

END OF
SLIDE

To return to the chapter summary click escape or close this document.



RESOURCES

11/1 Complex & Polygenic Inheritance 12.3

Obj. TSW predict possible combinations of alleles in a zygote from the genetic makeup of the parents during classroom activities. P.20 NB

<http://www.cde.ca.gov/ta/tg/sr/documents/cstrtqbiology.pdf>

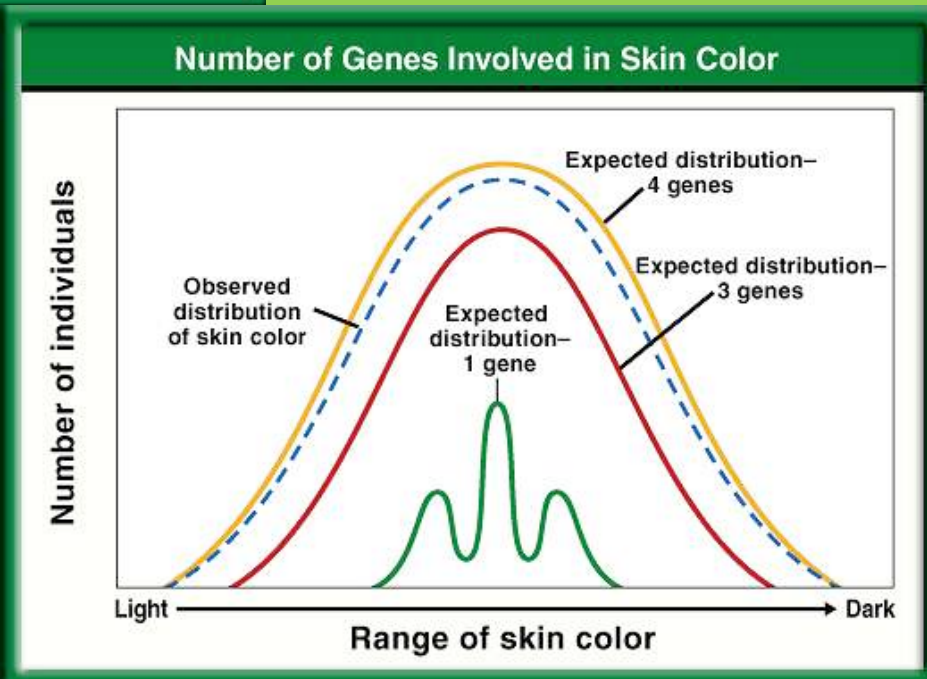
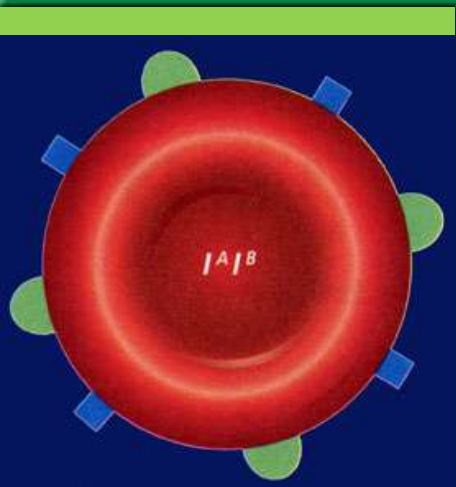
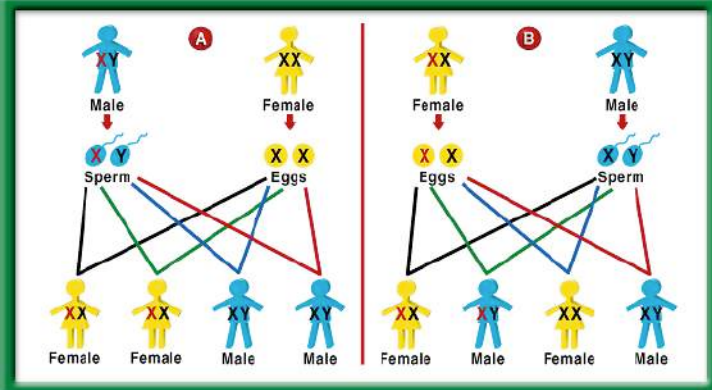

1. Determine the possible blood types of the children of parents that both have type AB.
2. Explain why a male with a recessive X – linked trait usually produces no female offspring with the trait.
3. Explain polygenic inheritance. Give an example. Draw the graph.

Fall Harvest Festival @ Bryte CCT November 3rd 5:30 – 7:30pm

- Decorations/ Materials
 - Lights (CRISTAL & DANNIELLA)
 - Hog Fencing & Zip ties (McAllister)
 - Tickets for Fundraisers (CARAH)
- Education
 - Plant a seed Station (REYNA & MARY)
 - Color the Rainbow – Color Fruits & Vegetables (ASMAANI)
 - Basket of Chicken Food & Chickens (MELINA)
 - PASCO – Probes - Jesse
 - **Tower Gardens**
- Food
 - Capresse Salad – use Basil leaves (EMILIANO)
 - Pico De Gallo – use all Peppers & Chips (MIGUEL, REYNA, NICOLE, YULISSA)
 - Radishes – Radish/Cucumber Salad (REYNA)
- Fun
 - Bean Bag Game (BEN)
- Fundraising
 - Sell Eggs \$5/dozen, \$7/ 18 eggs, \$9/2 Dozen (ZOE)
 - Chicken Races Donate \$ to watch – NO betting (ROXIE/BUTTER/ JUSTIN)
 - Sell Basil in bunches \$1/sprig (JEEVAN)
 - Chicken Squat – pay \$ to see if the hen poops on your Number in the pen
 - Winner – gift card to Starbucks/ Target
 - (GINGER,JUSTIN, MELINA)
 - Need Receipt book (SYED)
 - Roasting Pumpkin Seeds (CULINARY,NICOLE)

Needs:

- Don Schatzel = History of Bryte Campus
 - Justin Make sure you take notes
 - Johanna – Please ask Mr. Schatzel if he would be willing to talk to Justin about the History of Bryte or do a short write up to give Justin.
- BBCan – Bryte/ Broderick Action Network – Emiliano Contact them
- Georgios – District Office – Communications – Emiliano
- Show Movie – Wall-e

Opening /Closing Ceremony Practice

- Officers & Greenhand participants practice your lines with other students to memorize your part.
- We will play Kahoots on Thursday
- Everyone can take home a FFA Official Manual to practice.
- There will eventually be a test for your Greenhand Degree Awarded Dec. 15th at the FFA Banquet.

Number of Genes Involved in Skin Color

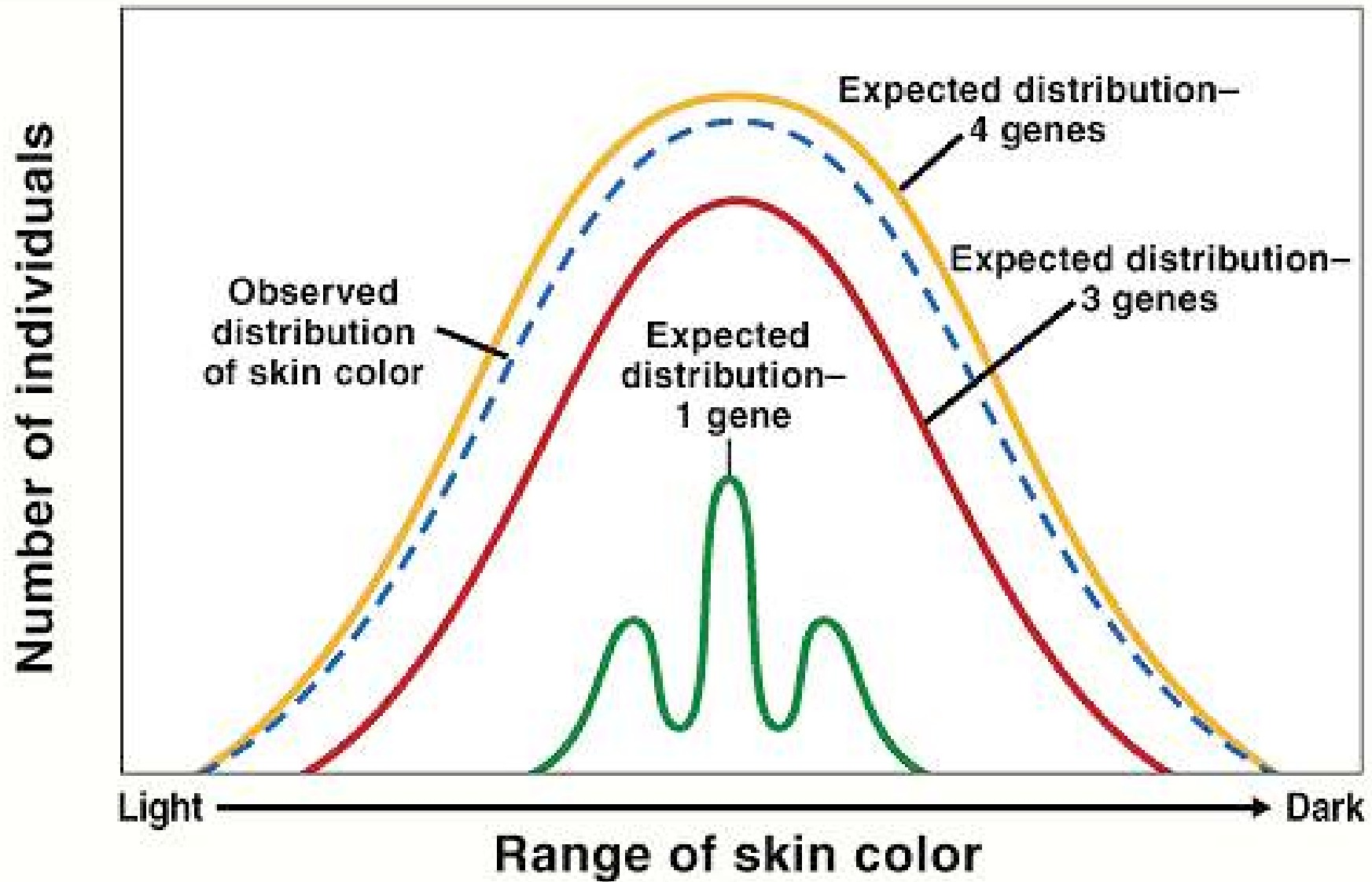

Stem Length Variation in Plants

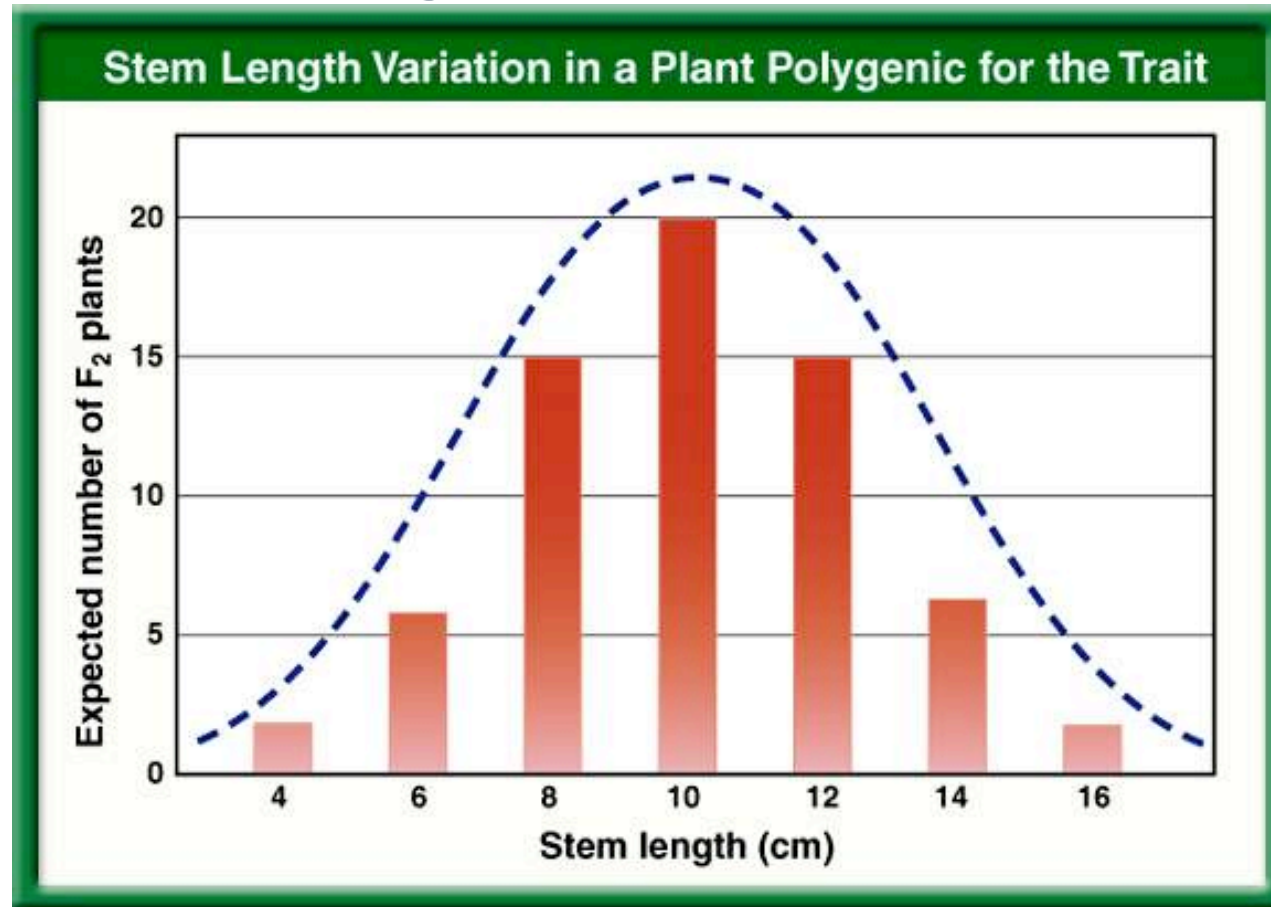

To return to the chapter summary click escape or close this document.

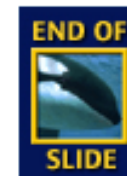

Number of Genes Involved in Skin Color

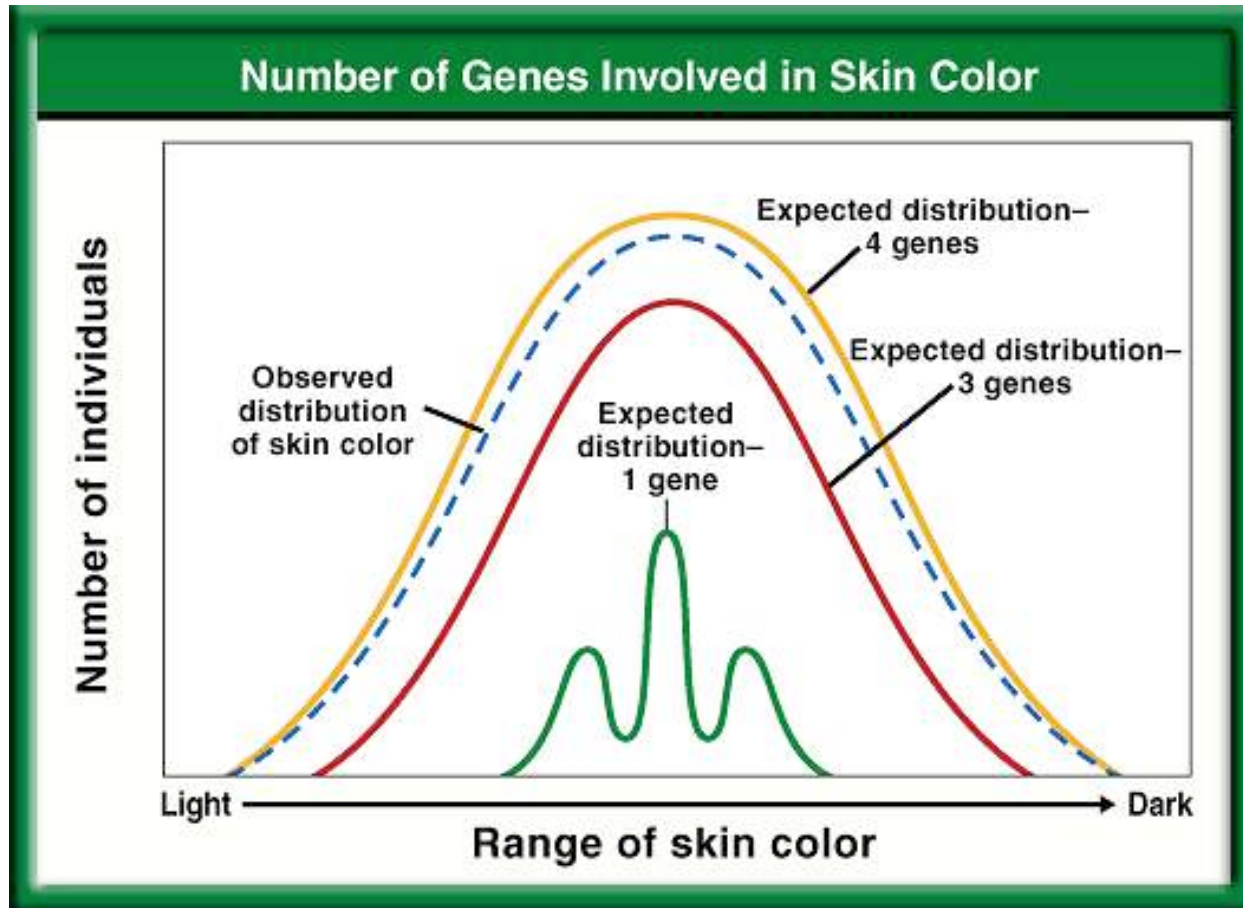

END OF
SLIDE

To return to the chapter summary click escape or close this document.



RESOURCES

11/2 Incomplete Dominance & Codominance 12.2

Obj. TSW demonstrate understanding of Pedigrees by finishing the study guide. P.22 NB

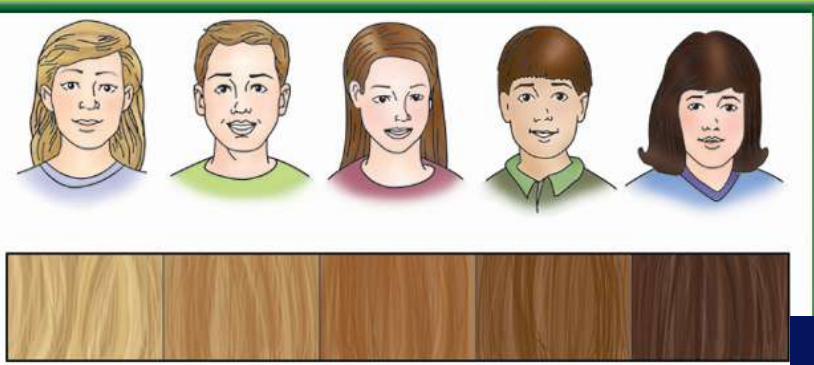

1. Draw a Punnett square and explain how incomplete dominance is inherited in Snap Dragon flowers.
2. Draw a Punnett square and explain how Codominance is inherited in Checkered chickens.
3. What color would the chicken be if feather color were inherited by incomplete dominance?

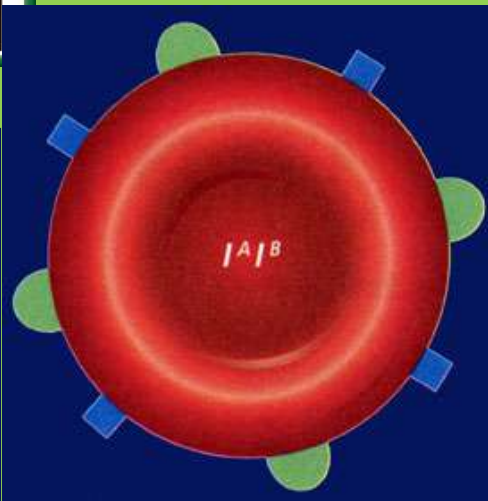
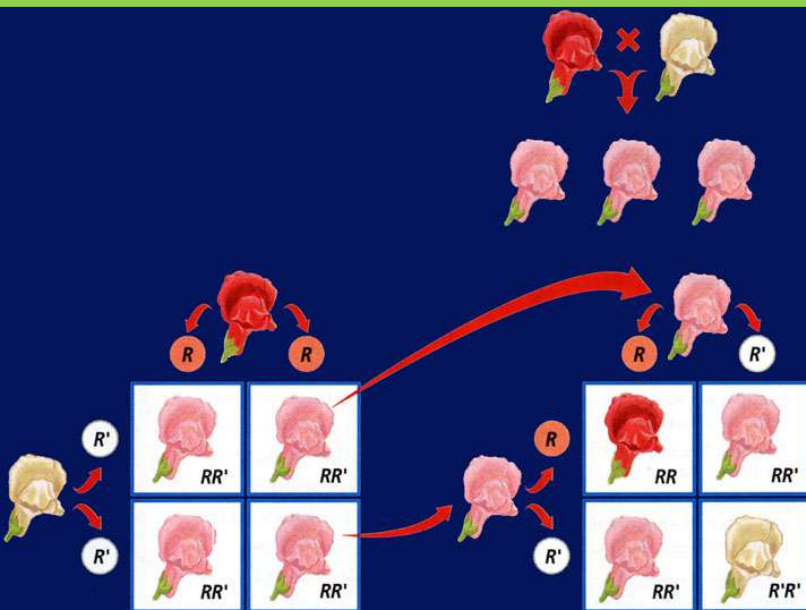

TABOO

- Dominant
- Allele
- Heterozygous
- Phenotype
- Karoytype
- Pure – Breeding

TABOO

- Recessive
- Genotype
- Homozygous
- Zygote
- Chromosome
- Hybrid

TABOO

- Probability
- Haploid
- Offspring
- Ratio
- DNA
- Meiosis

TABOO

- Diploid
- Punnett Square
- Mitosis
- Protein
- Gametes
- Homologous Chromosomes

3/21 Genetic Inheritance 10.1 & 10.2

Obj. TSW demonstrate understanding of genetic inheritance by doing well on the mendelian genetics quiz. P. 84NB

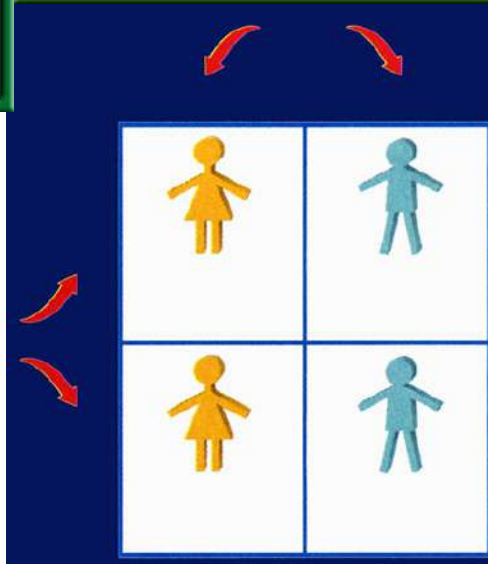
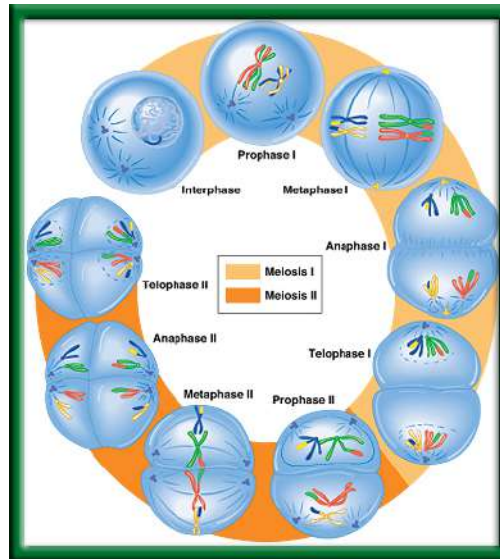

1. Draw the process of Meiosis (P.267BB) and explain it's purpose.
2. Explain and draw fertilization using an egg (n) & sperm (n).
3. Using a Punnett Square, show how sex determination is 50%.

3/24 Modes of Inheritance: Multiple Allelic CH 12

Obj. TSW learn how different traits are inherited in the

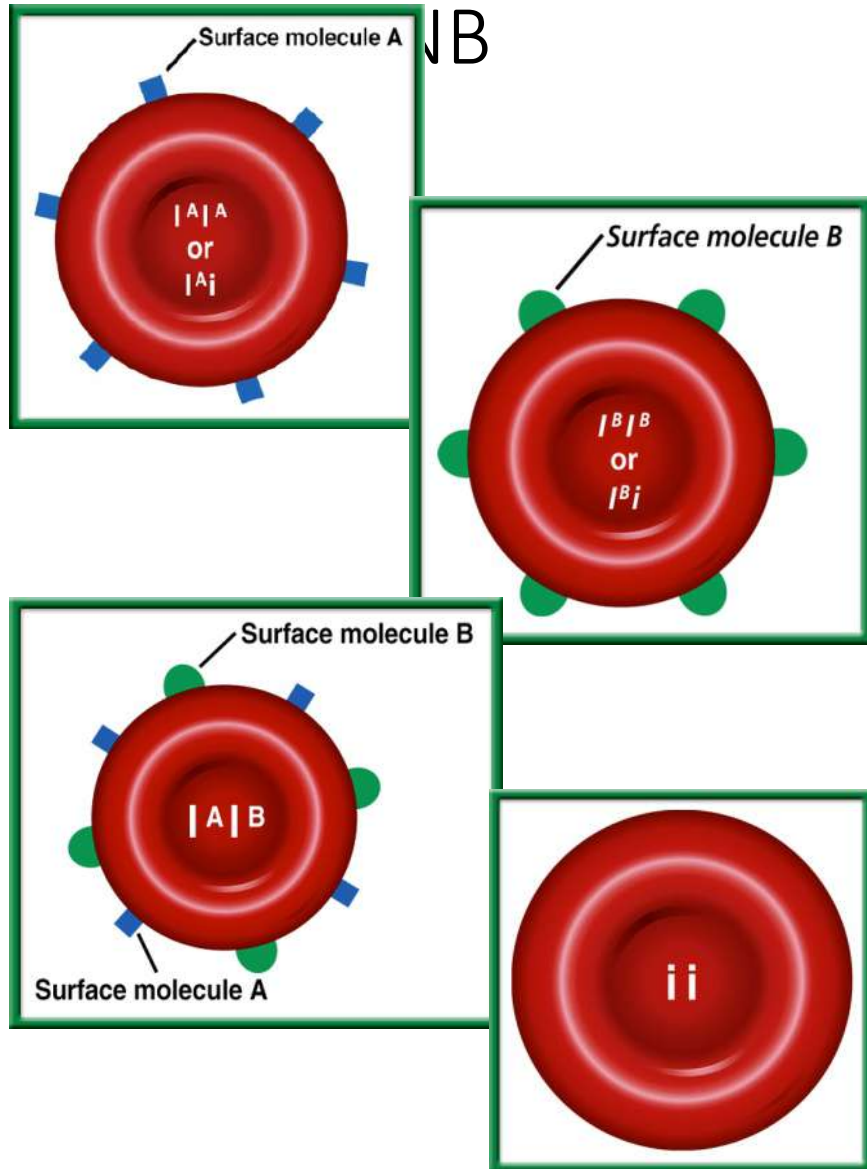

1. What are the 6 genotypes for blood?
2. What are the 4 phenotypes for blood?
3. Do a punnett square cross between two heterozygotes for A Blood and B blood.

[Blood Typing Game](#)

For every question you missed...

- Write 1 sentence: Why is the right answer right?
- Write 1 sentence: What was wrong about your answer?
- Staple to your quiz. Turn in.
- Finish your Study guide – due tomorrow.

11/3 Patterns of Heredity & Human Genetics 12.1 – 12.3

Obj. TSW discover how multiple alleles are inherited by doing their warm up and competing a Foldable. P. 24 NB

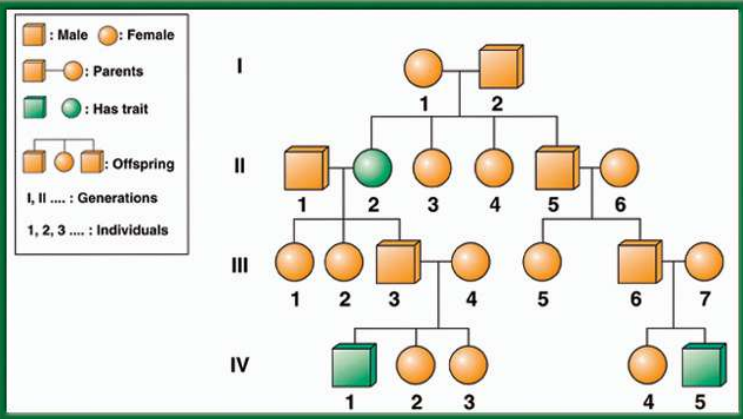

1. Write all the symbols used for a pedigree. Draw a pedigree of just your mom & dad and any siblings. (Youngest to the left)

2. Compare & contrast Incomplete Dominance and Codominance.

3. Write the 6 genotypes for the 4 phenotypes for blood. Make a Punnett square with two crosses.

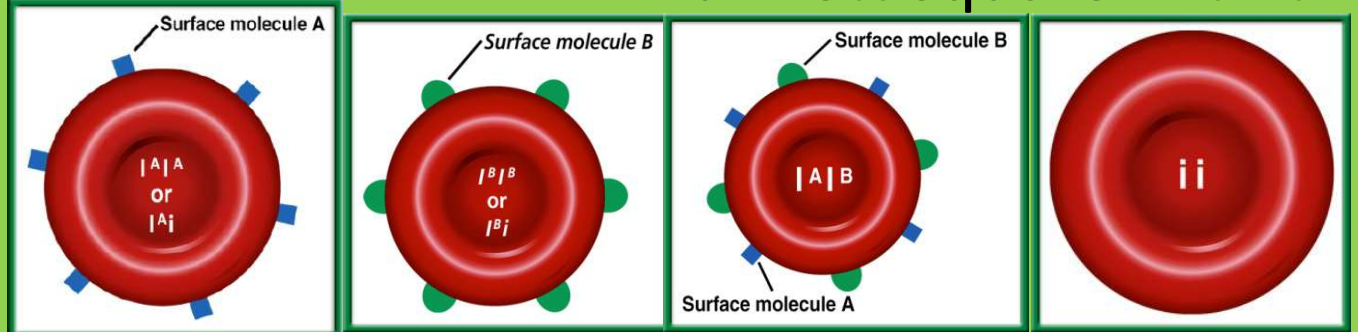
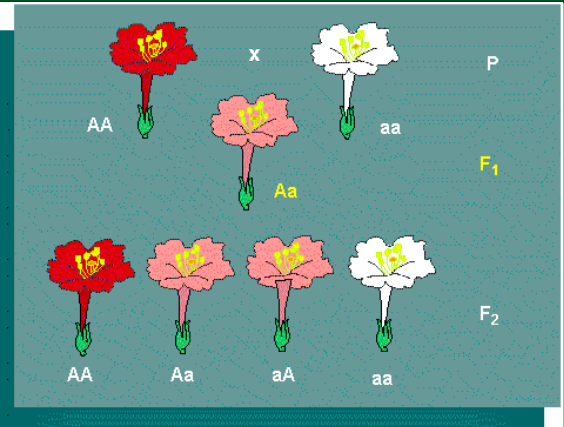

Free Mini Rex Bunnies!

You must take home, you can not care for them here.





Incomplete dominance: Appearance of a third phenotype p. 77NB

- When inheritance follows a pattern of dominance, heterozygous and homozygous dominant individuals both have the same phenotype.
- When traits are inherited in an **incomplete dominance** pattern, however, the phenotype of heterozygous individuals is intermediate between those of the two homozygotes.

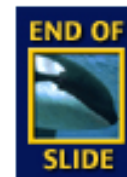

Incomplete dominance: Appearance of a third phenotype

- For example, if a homozygous red-flowered snapdragon plant (RR) is crossed with a homozygous white-flowered snapdragon plant ($R'R'$), all of the F_1 offspring will have pink flowers.

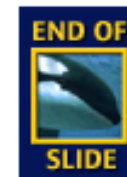

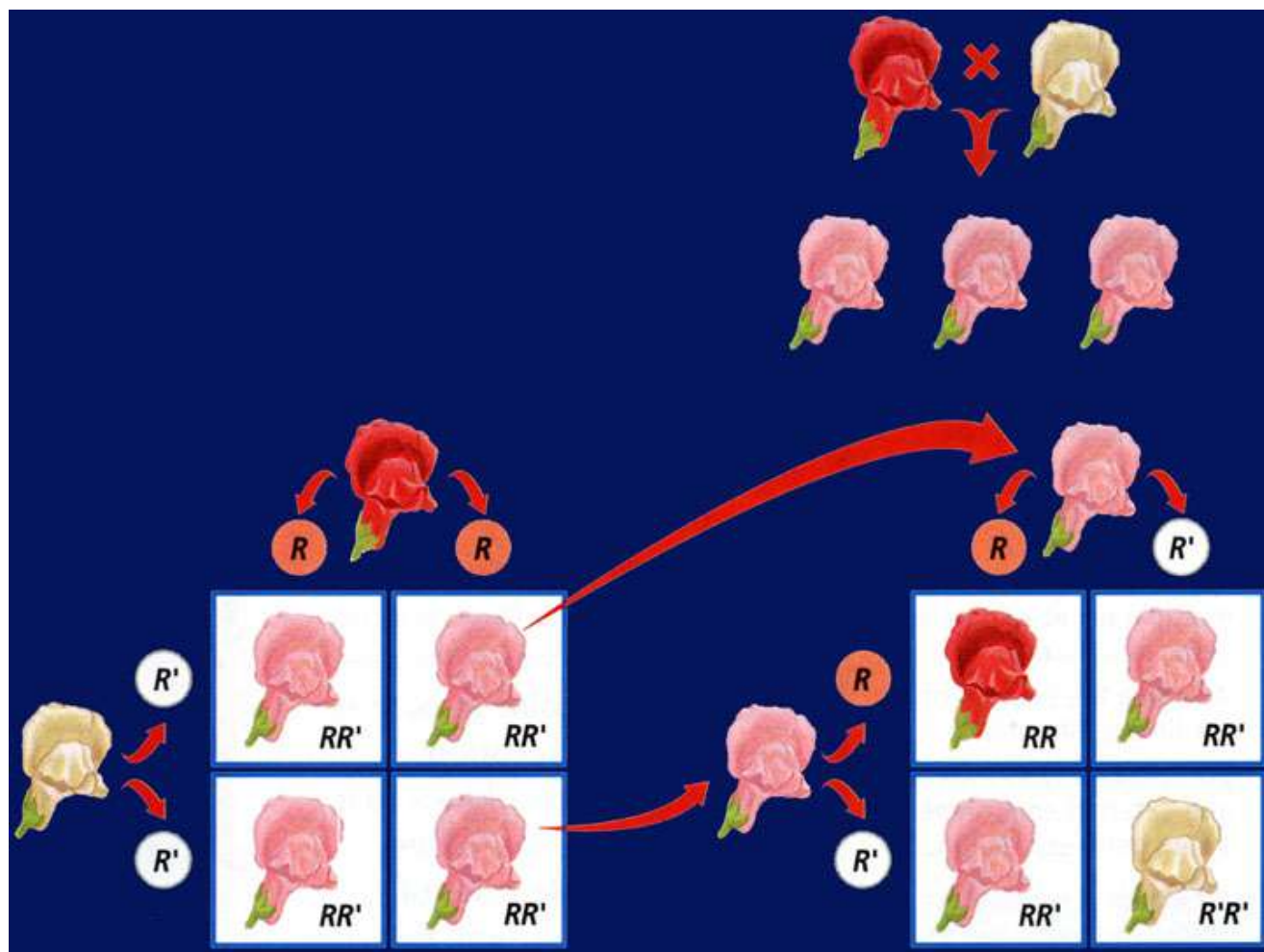

Incomplete
dominance:
Appearance
of a third
phenotype

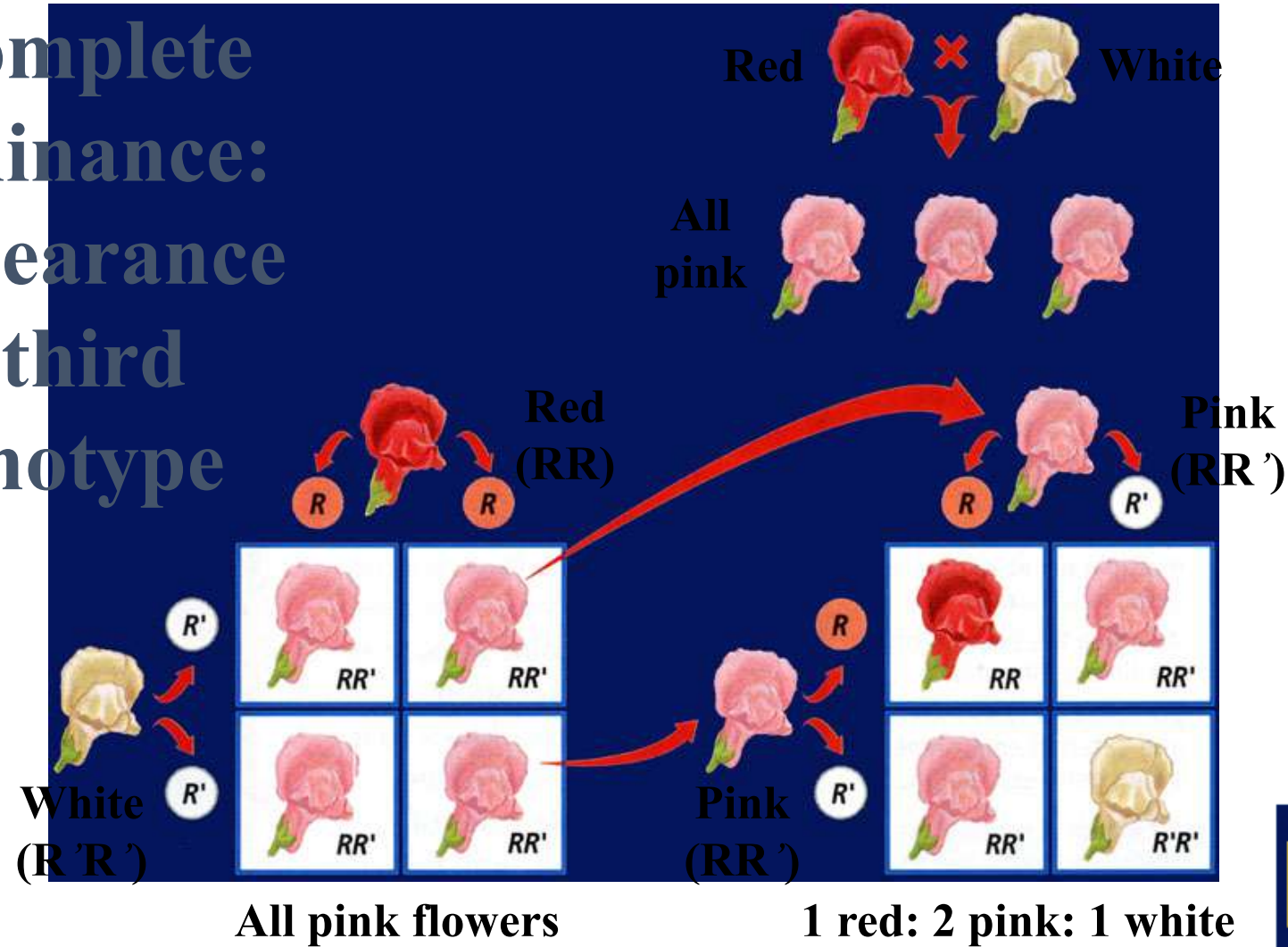

END OF
SLIDE

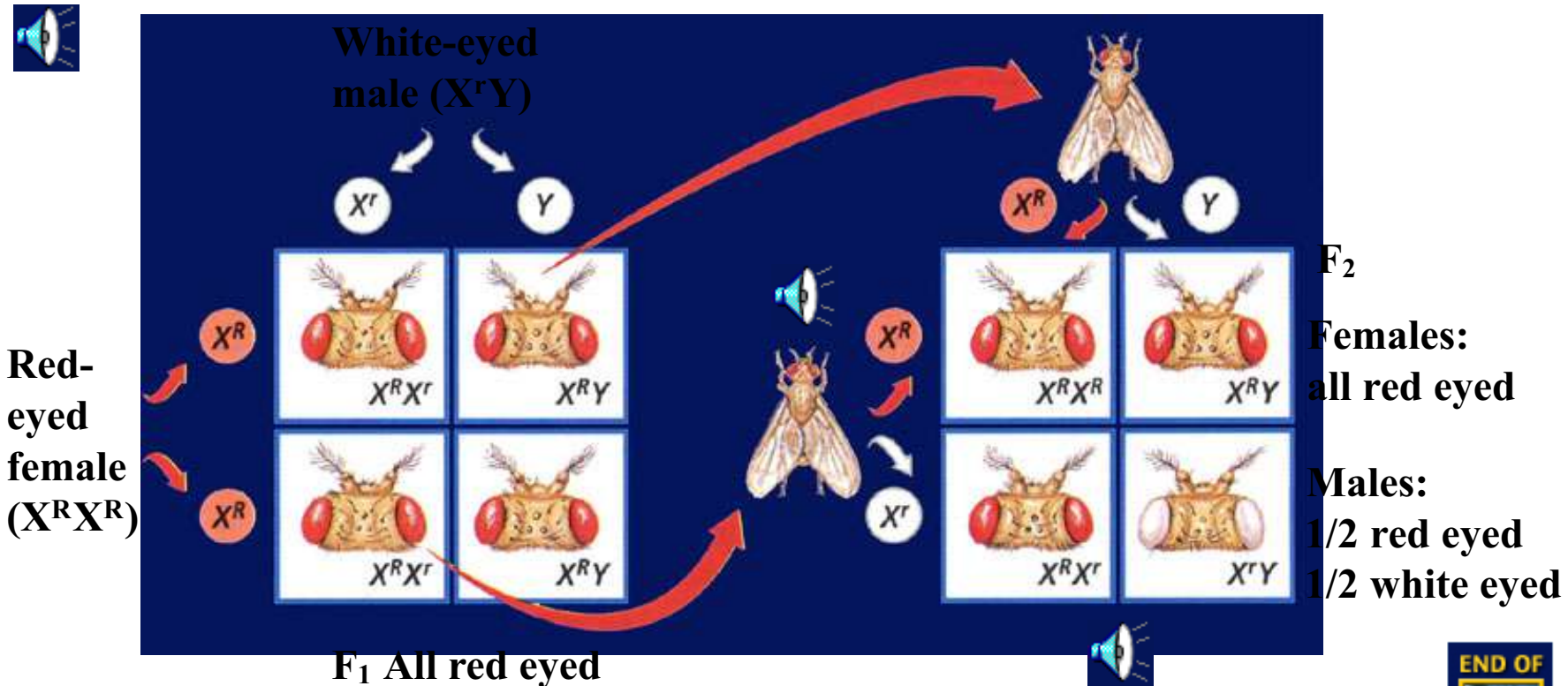

RESOURCES

Sex-linked inheritance 





END OF
SLIDE



RESOURCES

Codominance: Expression of both alleles

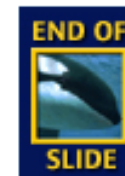
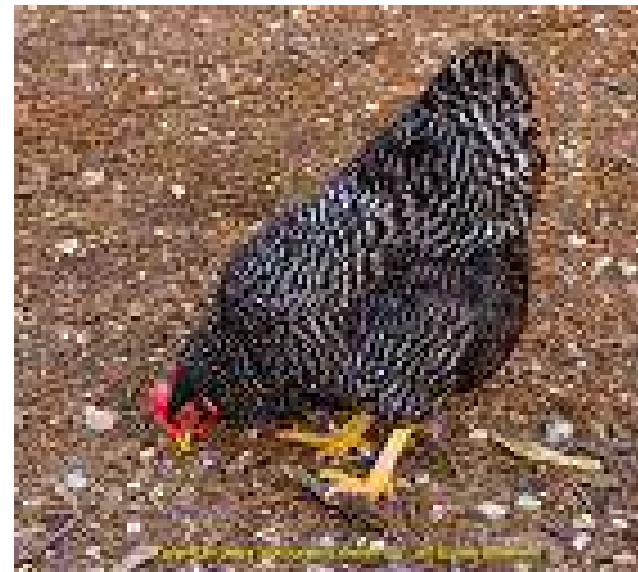
- **Codominant alleles** cause the phenotypes of both homozygotes to be produced in heterozygous individuals. In codominance, both alleles are expressed equally. 



Karyotyping Chromosomes P. 81NB P.329 BB

1. How many chromosomes are present in Spread #1? 46
Spread#2 46 Spread #3 46 Set A 47 Set B 47
2. Sperm 23 Chromosomes/egg 23 chromosomes
- 3 & 4 Spread #1 Girl (XX) Spread #2 Boy(XY) Spread #3 Girl (XX) Spread A Boy (XY) Spread B Boy (XXY)
- 5 & 6. Yes, Spread A is Trisomy 21, Spread B is XXY Chr 23.
7. Possible Problems for Trisomy 21- Down's Syndrome, XXY is Klinefelter's Syndrome
8. In today's medicine Karyotyping is used to determine the sex of the child and to see if there are abnormalities in the chromosomes.

Huntington's disease

- Huntington's disease is a lethal genetic disorder caused by a rare dominant allele.
- It results in a breakdown of certain areas of the brain.

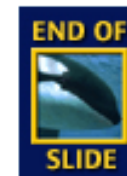

Huntington's disease

- Ordinarily, a dominant allele with such severe effects would result in death before the affected individual could have children and pass the allele on to the next generation.
- But because the onset of Huntington's disease usually occurs between the ages of 30 and 50, an individual may already have had children before knowing whether he or she is affected.

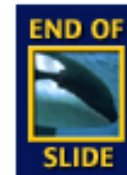

Pedigree- Tay Sachs Disease

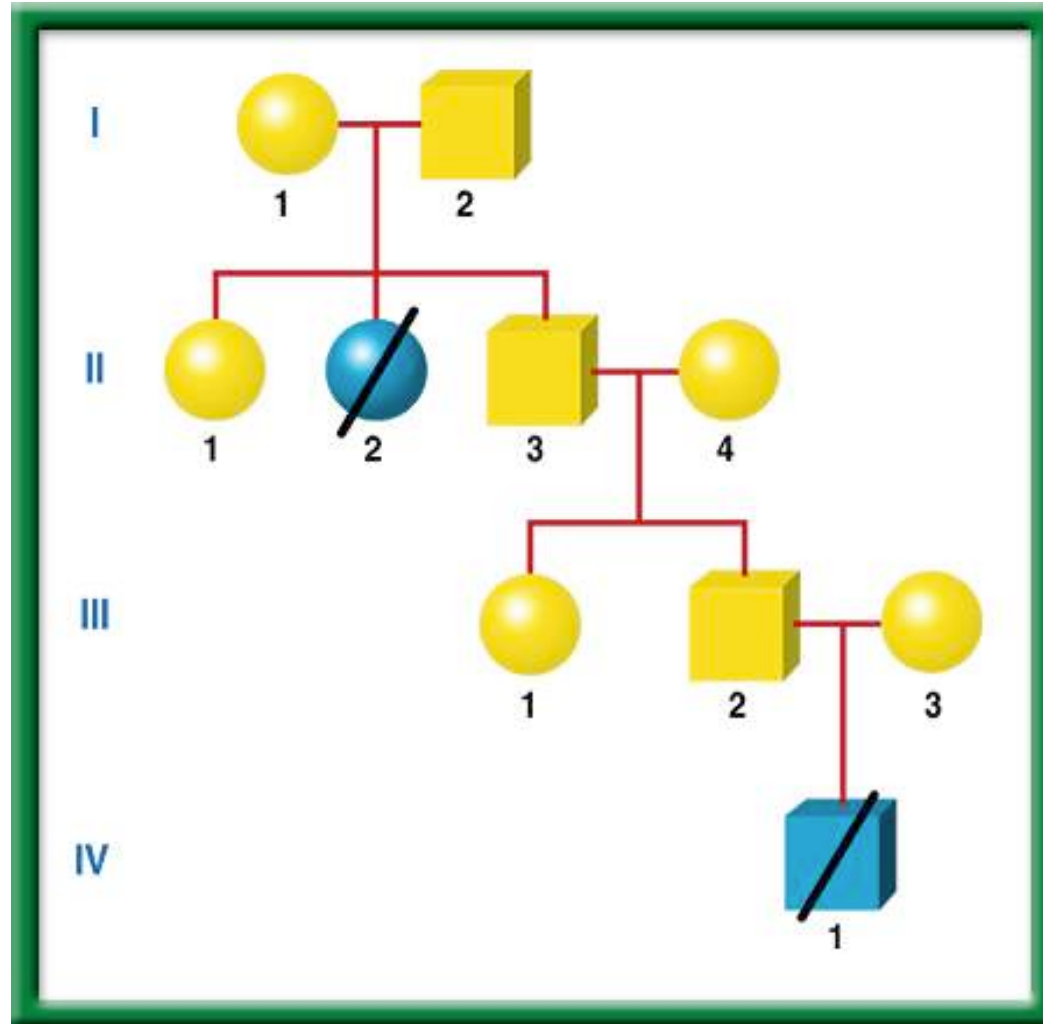

To return to the chapter summary click escape or close this document.

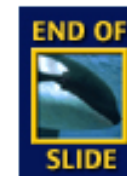

Chapter 12

Foldables Study Organizers

STEP 1

Fold a vertical sheet of notebook paper from side to side.

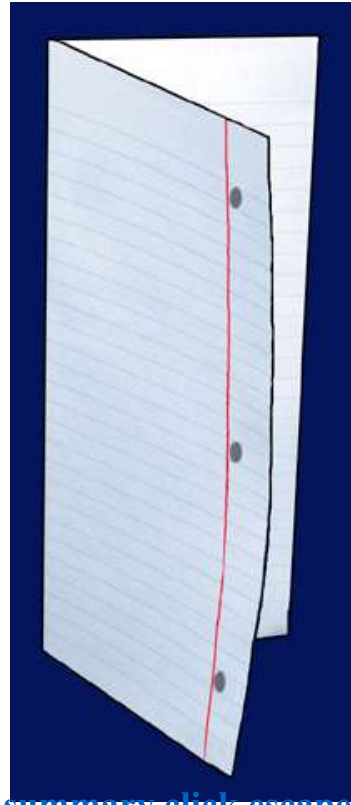

To return to the chapter summary click escape or close this document.

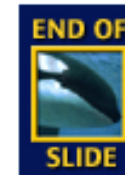

STEP 2

Cut along every fifth line of only the top layer to form tabs.

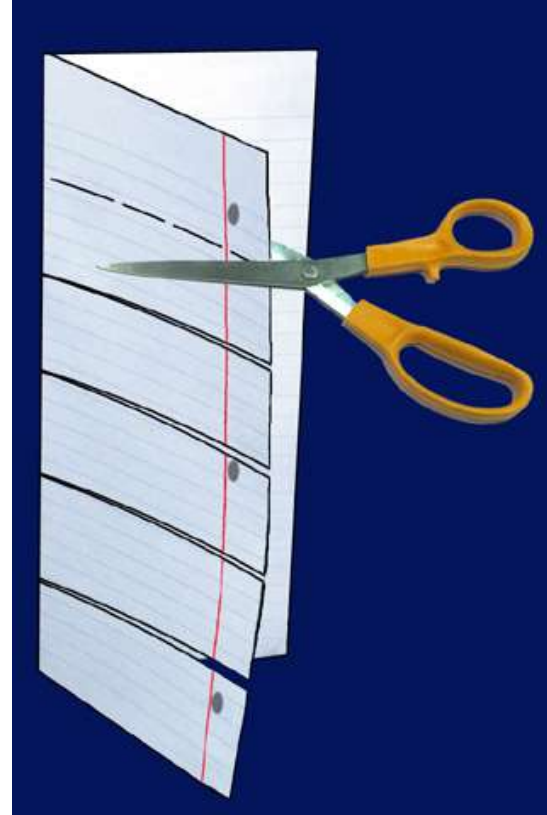

To return to the chapter summary click escape or close this document.

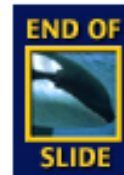

STEP 3

P. 19 NB

Label each tab.

Explain how the traits are inherited by giving an example of a punnett square for each. Make sure you write the key for the genotypes.



To return to the chapter summary click escape or close this document.

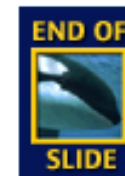

<http://learn.genetics.utah.edu/>

<http://www.cde.ca.gov/ta/tg/sr/documents/cstrtqbiology.pdf>

[Karyotyping Activity](#)

http://www.biology.arizona.edu/human_bio/activities/karyotyping/karyotyping.html

1. Heredity & Traits

1. Make a Karyotype
2. Using Karyotypes to predict genetic disorders

2. Genetic Disorders Library

1. Cystic Fibrosis
2. Down's Syndrome
3. Huntington's disease
4. Sickle Cell Anemia
5. PKU
6. Duchenne's Muscular Dystrophy
7. Osteogenesis Imperfecta
8. Leukemia
9. Achondroplasia

CDE Website –2008 Biology
Released Test Questions

Multiple Alleles Govern Blood Type

Human Blood Types		
Genotypes	Surface Molecules	Phenotypes
$I^A I^A$ or $I^A i$	A	A
$I^B I^B$ or $I^B i$	B	B
$I^A I^B$	A and B	AB
ii	None	O

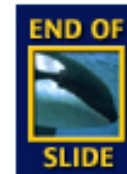

Multiple phenotypes from multiple alleles

- Although each trait has only two alleles in the patterns of heredity you have studied thus far, it is common for more than two alleles to control a trait in a population.
- Traits controlled by more than two alleles have **multiple alleles**. 

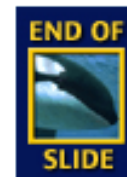

The importance of blood typing

- Determining blood type is necessary before a person can receive a blood transfusion because the red blood cells of incompatible blood types could clump together, causing death.

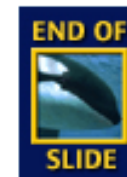

The ABO Blood Group

- The gene for blood type, gene *I*, codes for a molecule that attaches to a **membrane protein** found on the surface of red blood cells.
- The I^A and I^B alleles each code for a different molecule.
- Your immune system recognizes the red blood cells as belonging to you. If cells with a different surface molecule enter your body, your immune system will attack them.

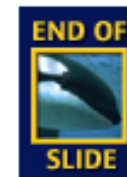

Phenotype A

- The I^A allele is dominant to i , so inheriting either the $I^A i$ alleles or the $I^A I^A$ alleles from both parents will give you type A blood.
- Surface molecule A is produced.

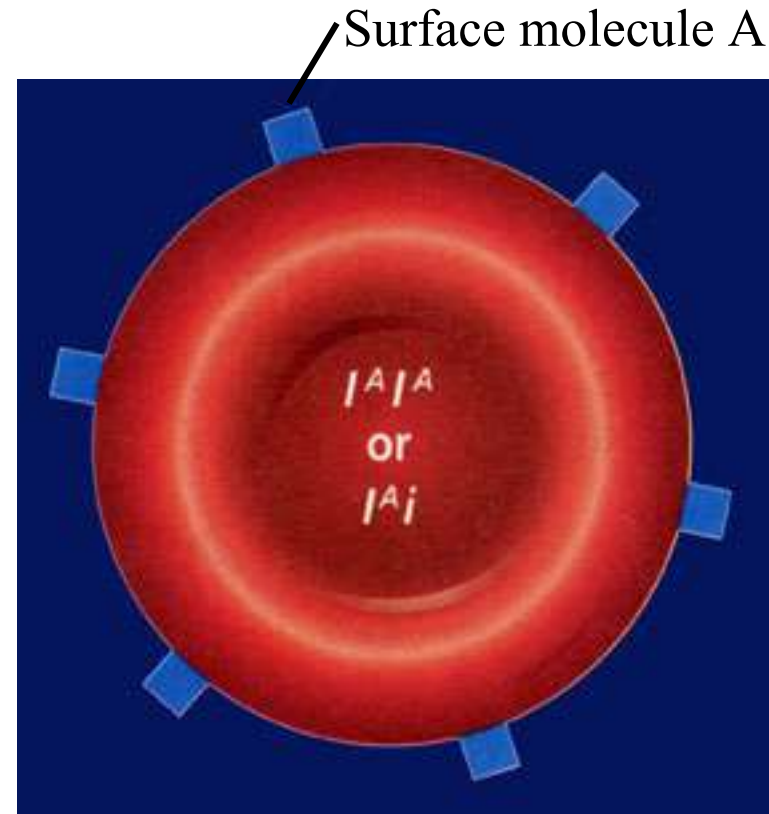

END OF
SLIDE



RESOURCES

Phenotype B

- The I^B allele is also dominant to i .
- To have type B blood, you must inherit the I^B allele from one parent and either another I^B allele or the i allele from the other.
- Surface molecule B is produced.

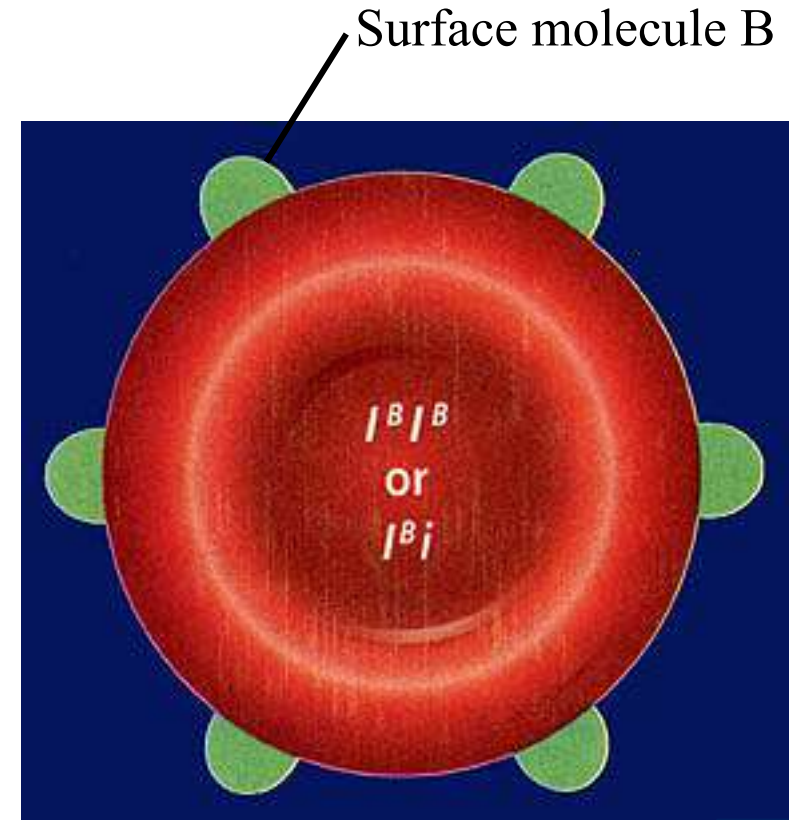

END OF
SLIDE



RESOURCES

Phenotype AB

- The I^A and I^B alleles are codominant.
- This means that if you inherit the I^A allele from one parent and the I^B allele from the other, your red blood cells will produce both surface molecules and you will have type AB blood.

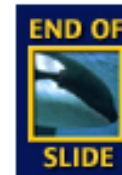
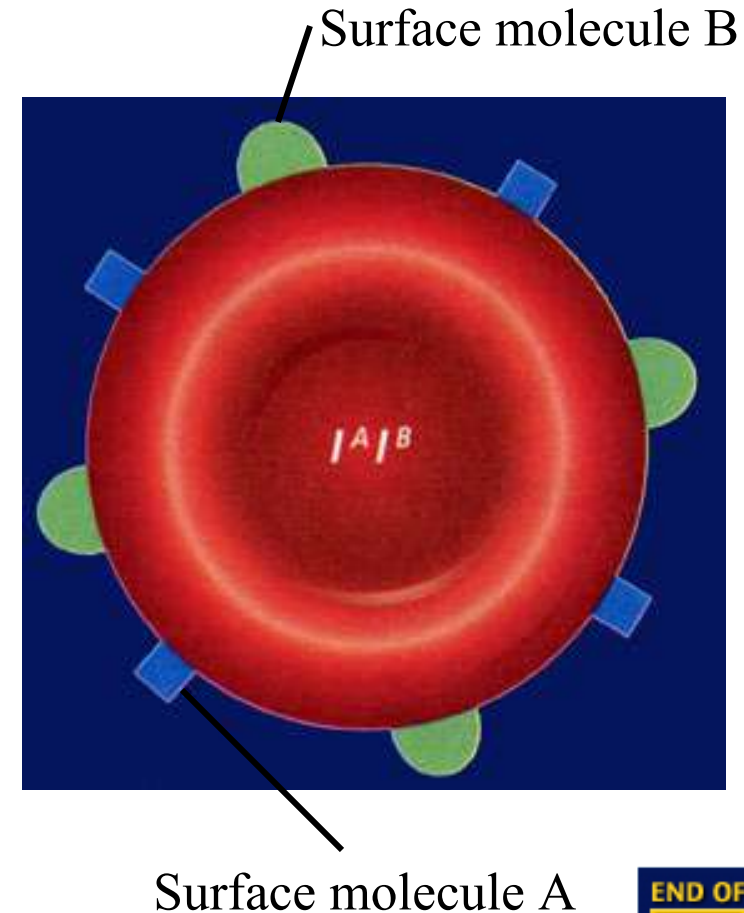

Phenotype O

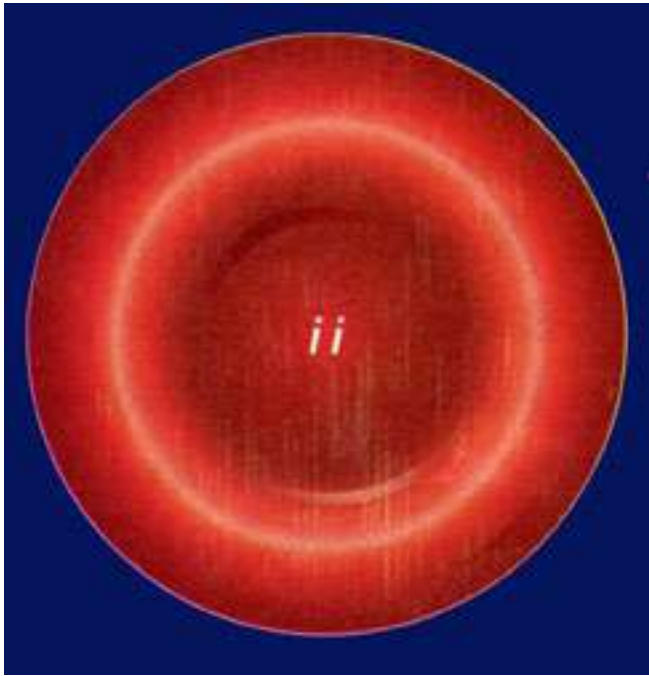

- The *i* allele is recessive and produces no surface molecules.
- Therefore, if you are homozygous *ii*, your blood cells have no surface molecules and you have blood type O.

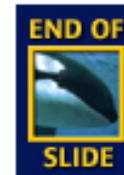

Question 2

According to the table, if you inherit the I^A allele from one parent and the I^B allele from the other parent, you will have type _____ blood.

Human Blood Types		
Genotypes	Surface Molecules	Phenotypes
$I^A I^A$ or $I^A i$	A	A
$I^B I^B$ or $I^B i$	B	B
$I^A I^B$	A and B	AB
	None	O

A. A

C. AB

B. B

D. O

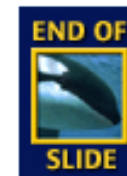

To return to the chapter summary click escape or close this document.



The answer is C. The I^A and I^B alleles are codominant. Your red blood cells would produce both surface molecules and you would have type AB blood.

Human Blood Types		
Genotypes	Surface Molecules	Phenotypes
$I^A I^A$ or $I^A i$	A	A
$I^B I^B$ or $I^B i$	B	B
$I^A I^B$	A and B	AB
ii	None	O

To return to the chapter summary click escape or close this document.

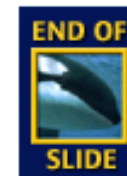

Question 1

What is the difference between simple Mendelian inheritance and codominant inheritance?

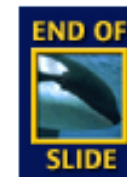

In Mendelian inheritance, heterozygous individuals will display the inherited dominant trait of the homozygotes. When traits are inherited in a codominant pattern the phenotypes of both homozygotes are displayed equally in the heterozygotes.

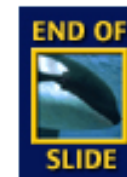

Sickle-cell disease

- The change in shape occurs in the body's narrow capillaries after the hemoglobin delivers oxygen to the cells.

Normal red
blood cell

Sickle cell

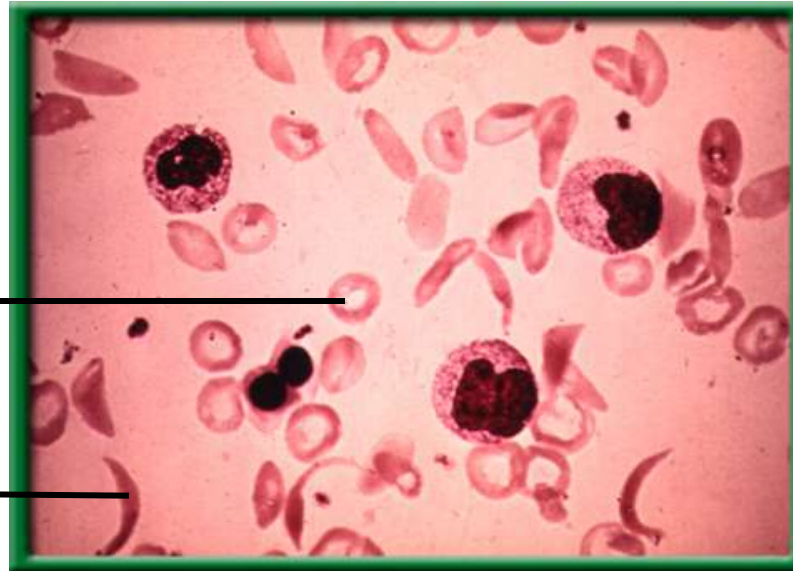

END OF
SLIDE



RESOURCES

Sickle-cell disease

- Abnormally shaped blood cells, slow blood flow, block small vessels, and result in tissue damage and pain.

Normal red
blood cell

Sickle cell

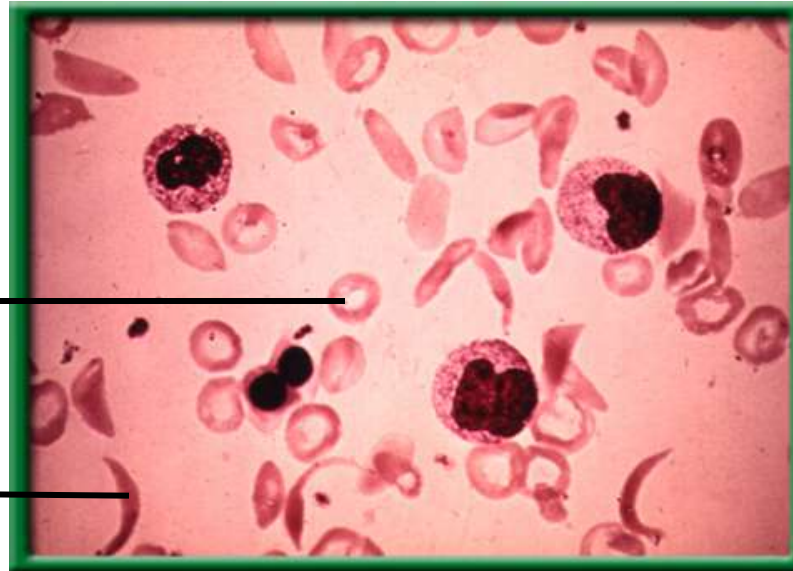

END OF
SLIDE



RESOURCES

Symbols Used by Geneticists

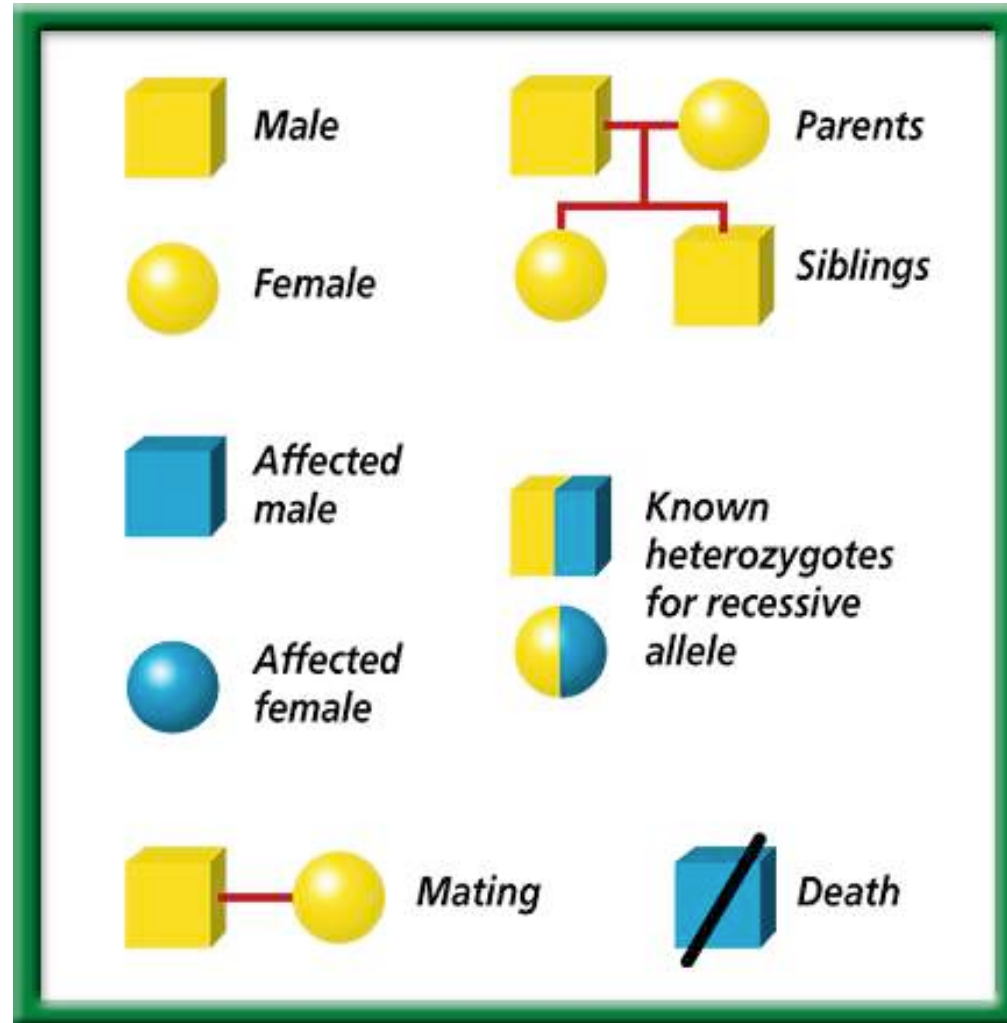

To return to the chapter summary click escape or close this document.

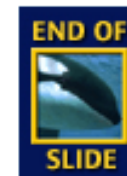

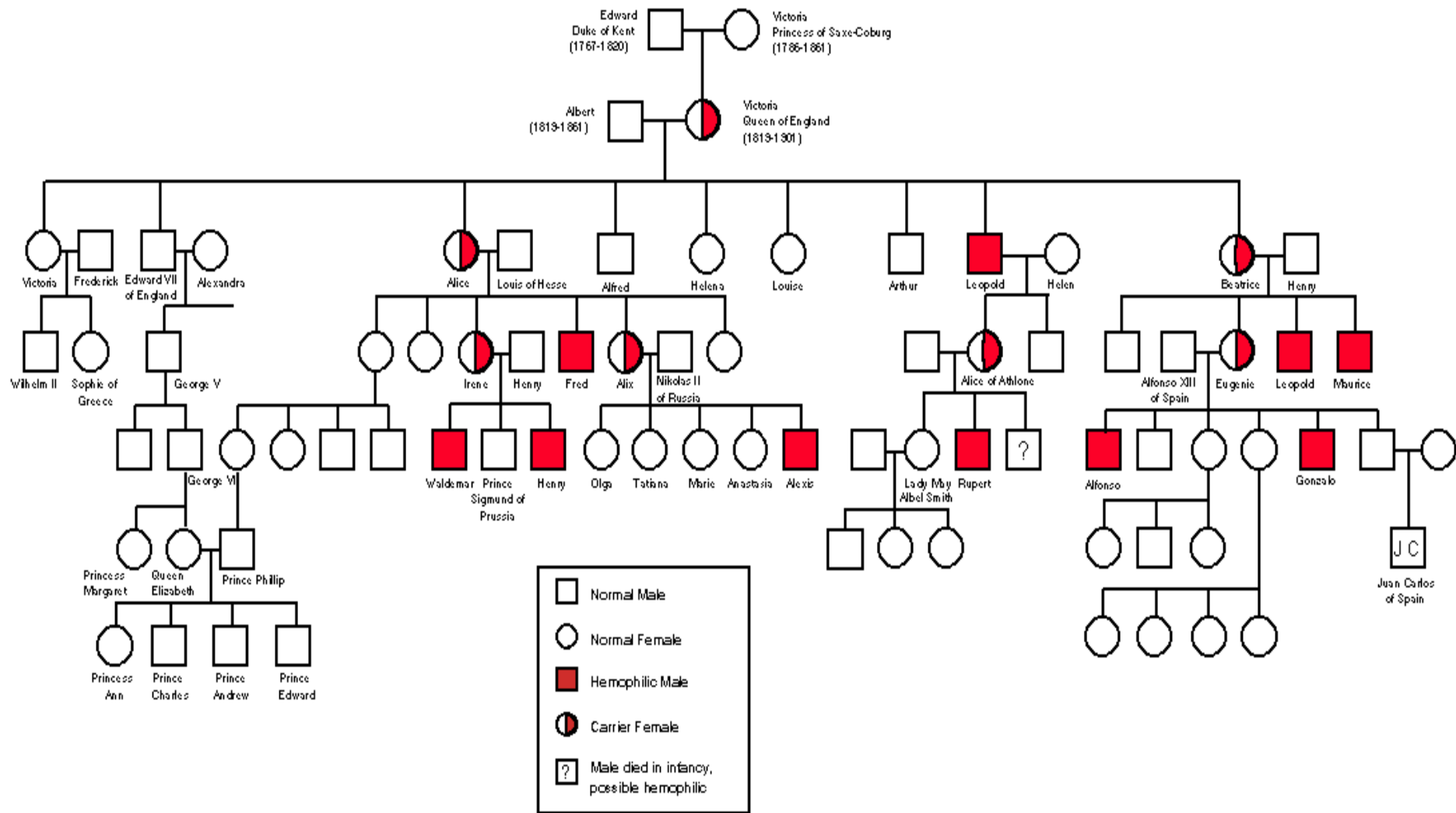

(A)

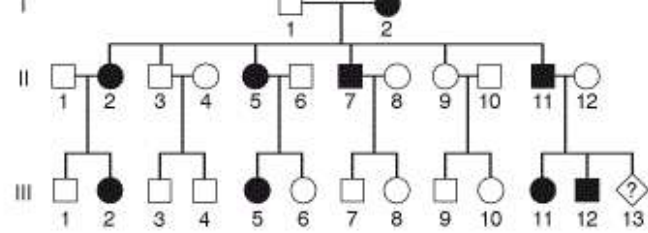

(B)

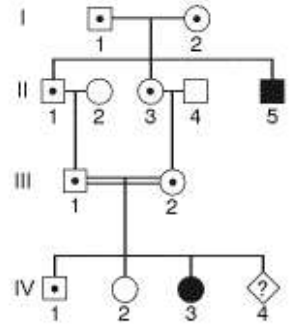

(C)

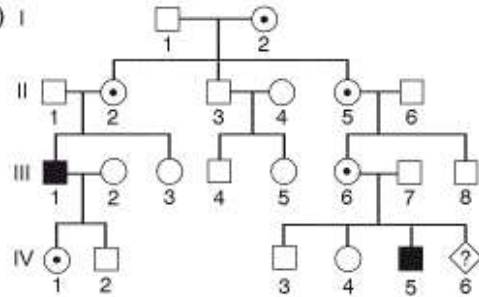

(D)

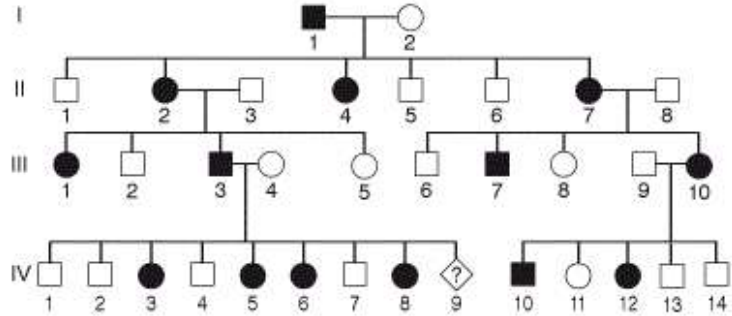

(E)

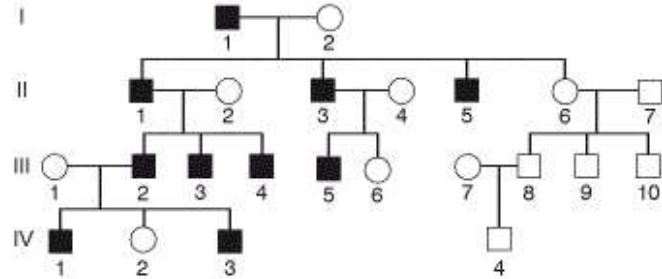

Family Pedigree Project

- Show 3 Generations
- One side of the family
- Include at least 12 individuals
- Show only 1 trait
- Show the key of what the traits are
- Show affected individuals with the trait (color)
- Label Autosomal or sex-linked
- Label Dominant or recessive
- Write Genotypes

Daniel Ponzi's pedigree

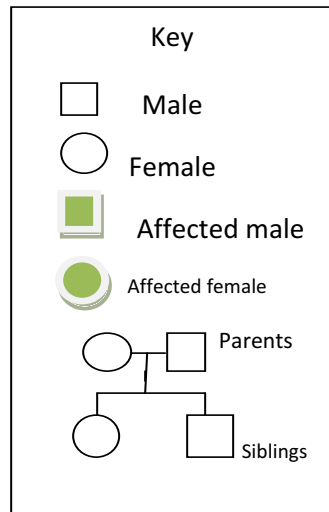
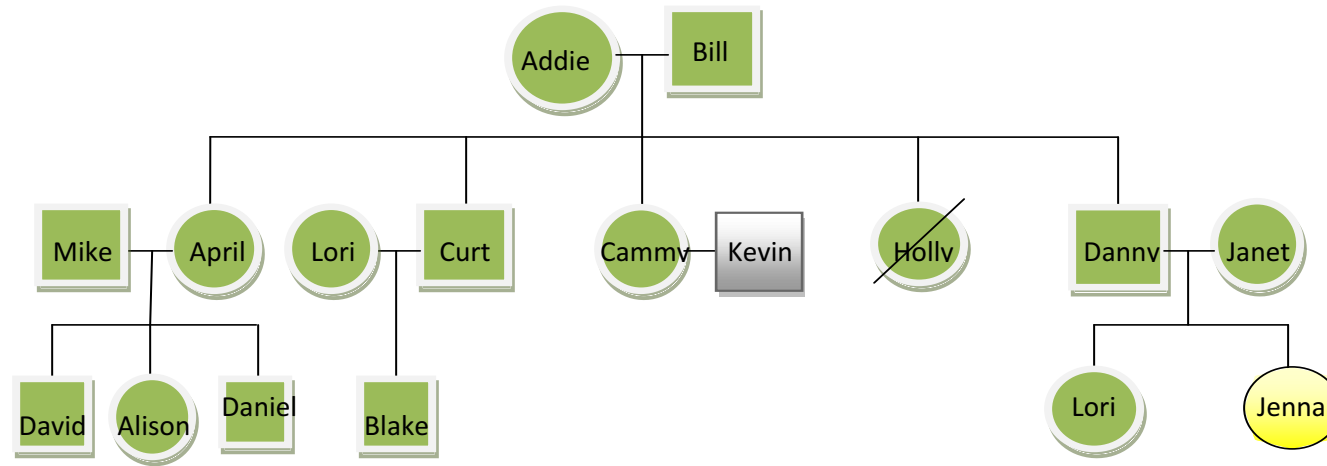

Dominant-Autosomal

Trait-brown hair

Kristen Mcadood's Family Pedigree

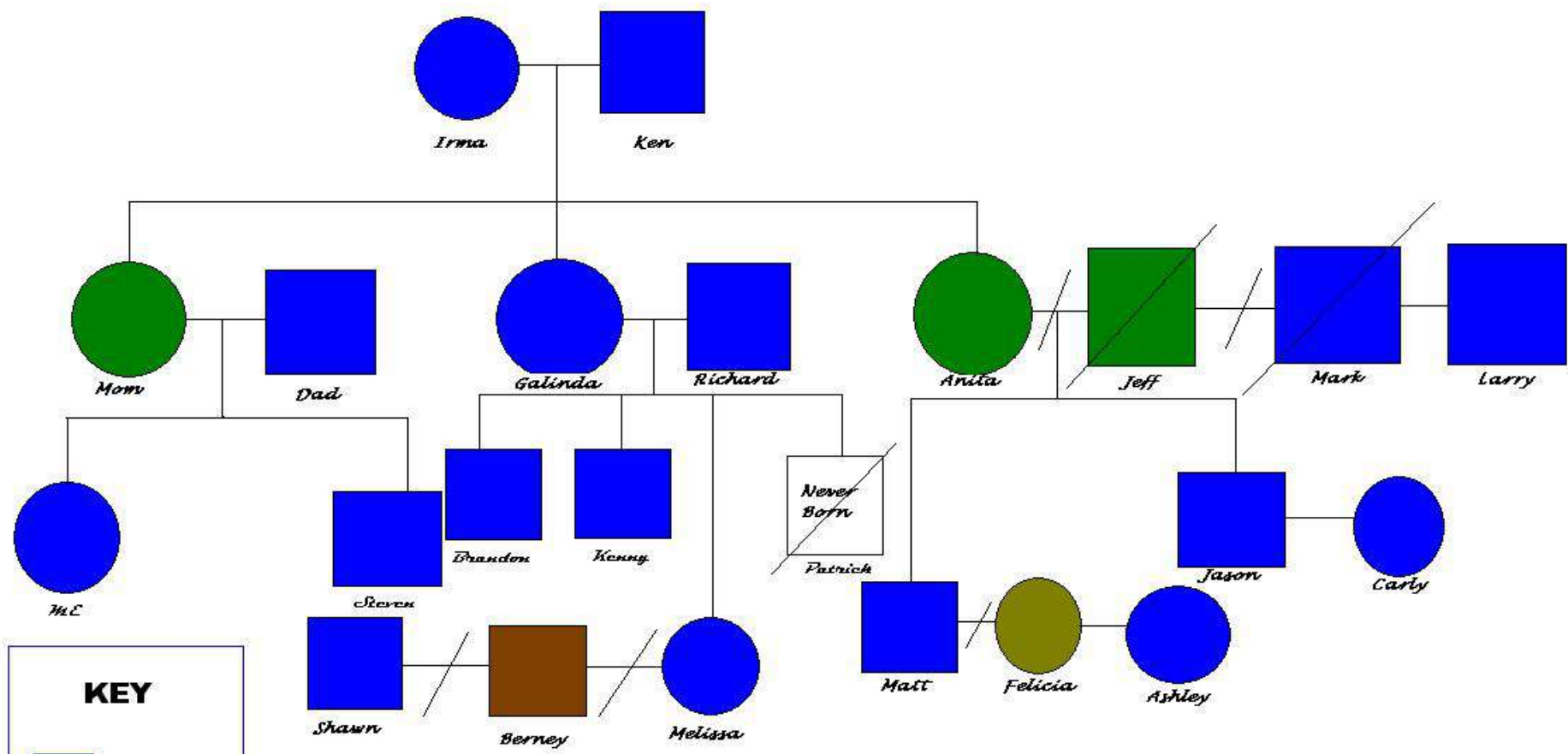

KEY

- Male Eye color
- Female Eye color
- Parents, mated
- Offspring, siblings

*Trait- Eye Color
Autosomal-Dominant*

Pedigree Chart

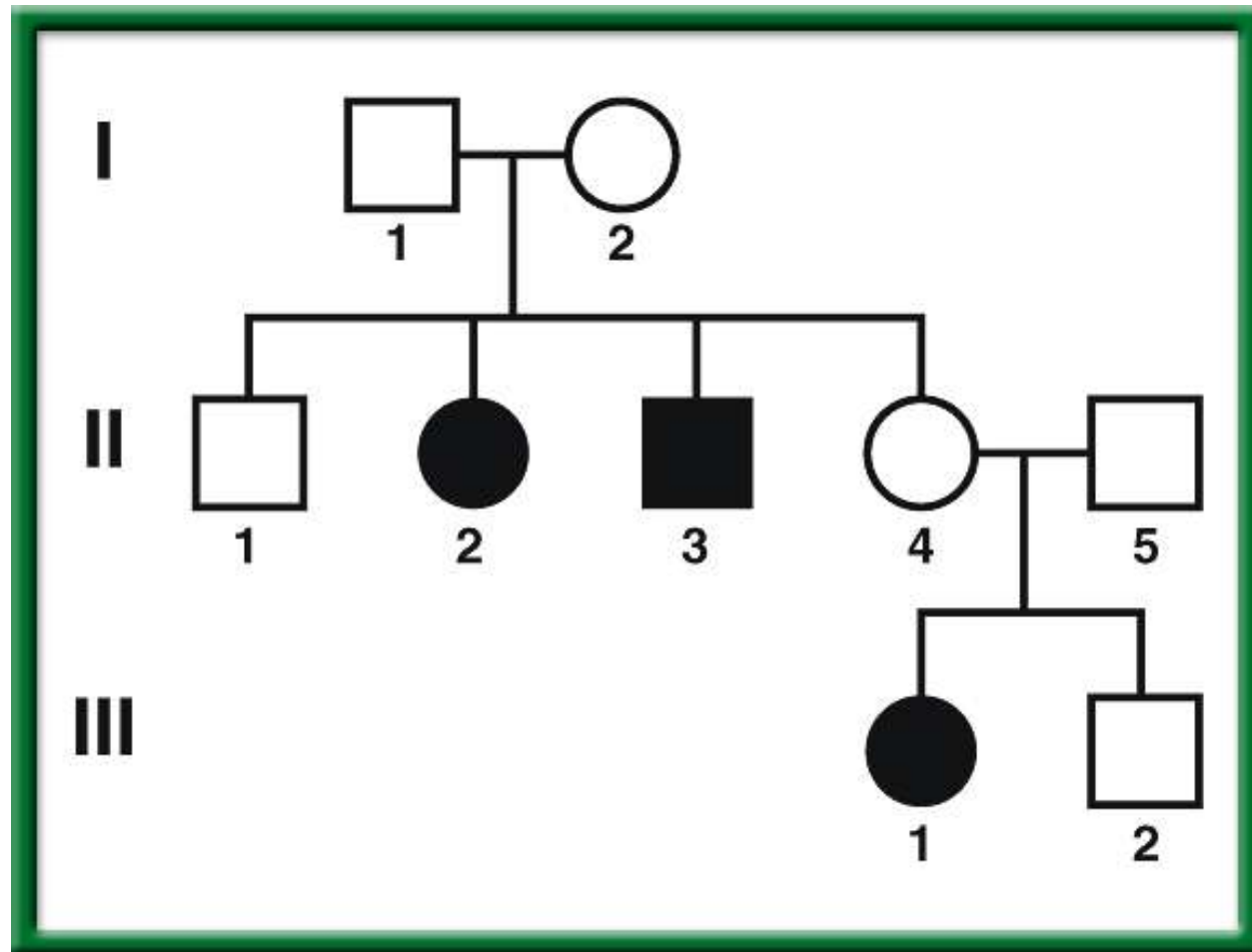

END OF
SLIDE

To return to the chapter summary click escape or close this document.



RESOURCES

3/26 Complex Inheritance of Human Traits 12.3

Obj. TSW predict possible combinations of alleles in a zygote from the genetic make up of the parents by working on a pedigree. P.86 NB

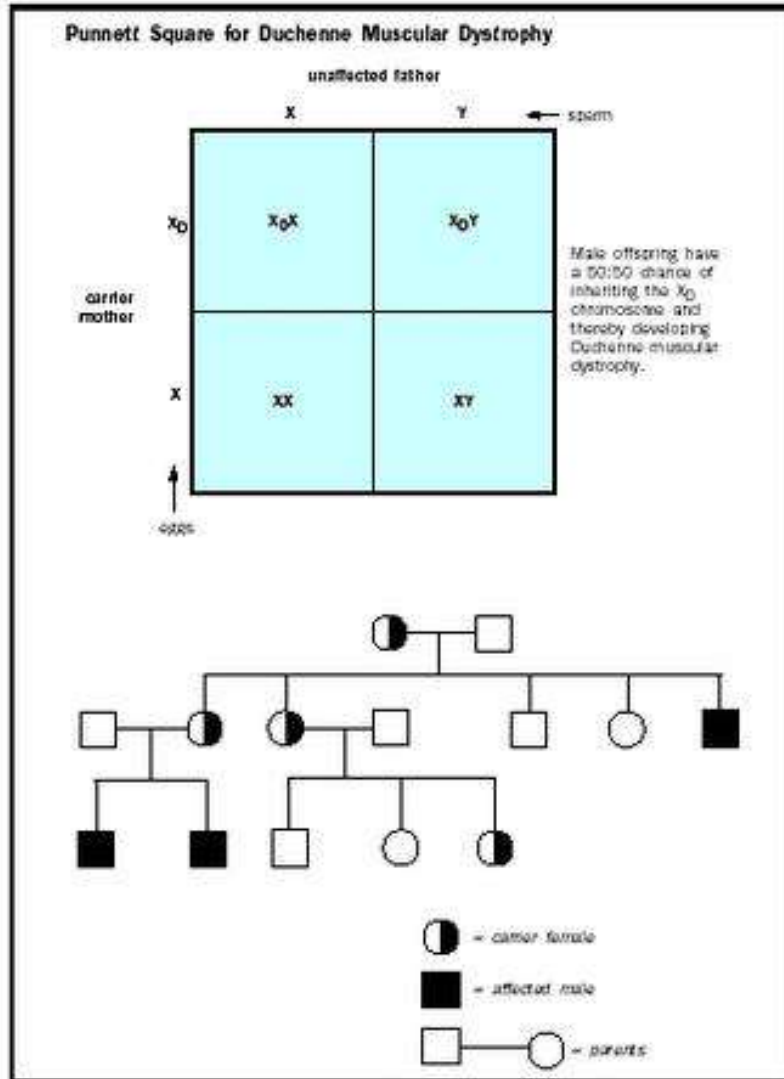

1. Reading the Pedigree from the Problem Solving Lab 12.3 p. 326, Is this an autosomal or sex-linked disorder? How do you know?
2. Using the same pedigree as above, What would be the probability of the individual IV-1 having a daughter that is a carrier, and a son inheriting the disorder?
3. Compare & Contrast Autosomes and Sex Chromosomes.

Study Guide for Genetic Inheritance Test

1. Crossing over is when two sister chromatids cross over and exchange genetic information. It happens during Meiosis to increase genetic variation in the species.

2.

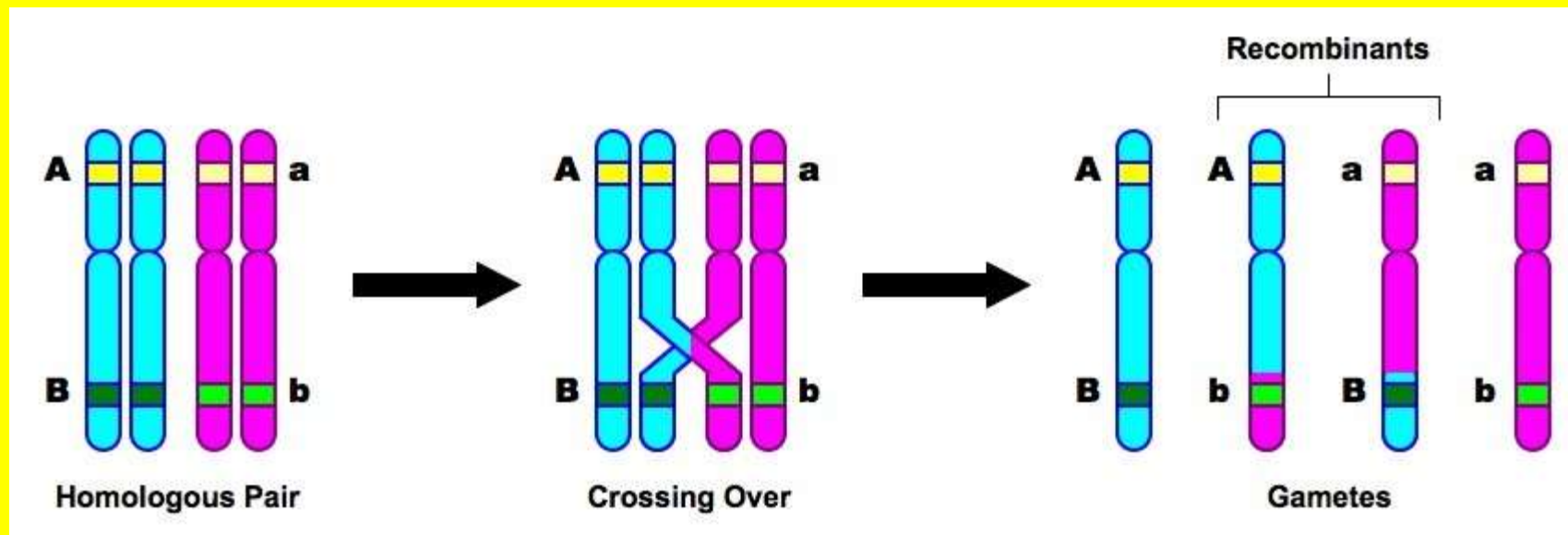

3. Genetic Recombination is the exchange of genetic material on the sister chromatids during Meiosis, it increases genetic variation.
4. Gamete:
Zygote:
Offspring:
Homozygous:
Heterozygous:
Heredity:
Diploid:
Haploid:
Allele:
Gene:

5. Mendel's 1st law is the Law of Segregation. It states that the two alleles for a trait will separate into different gametes.
6. Mendel's 2nd law is the Law of Independent Assortment. It states that traits are inherited independently of each other.
7. A gamete has one (1) allele for each trait. It is haploid.
8. A zygote has two (2) alleles for each trait. It is diploid.
9. An adult human has two (2) alleles for each trait. They are diploid.
10. Finding a person's genotype – Do a Punnett Square.
11. Finding a person's phenotype – Look at them.

12. Pointy Ears = A

- a. Heterozygous = Aa
- b. Punnett Square

Floppy Ears = a

- c.

AA	25%	Pointy Ears
Aa	50%	Pointy Ears
Aa	25%	Floppy Ears
- d. Pointy Eared puppy = 75%
- e. Floppy Eared puppy = 25%