

Short Response/Gridded Response

Record your answers on the answer sheet provided by your teacher or on a sheet of paper.

11. Determine whether each of the following situations calls for a *survey*, an *observational study*, or an *experiment*. Explain the process.
- Christine wants to find out if a particular plant food helps plants to grow faster than just water.
 - Allison wants to find opinions on favorite candidates in the upcoming student council elections.
 - Manuel wants to find out if people who get regular exercise sleep better at night.

12. **GRIDDED RESPONSE** Carla received a map of some walking paths through her college campus. Paths A, B, and C are parallel. What is the length x to the nearest tenth of a foot?

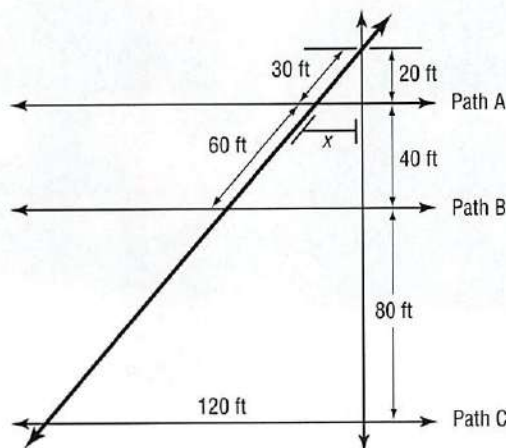

13. Alex wants to find the area of a triangle. He draws the triangle on a coordinate plane and finds that it has vertices at $(2, 1)$, $(3, 4)$, and $(1, 4)$. Find the area of the triangle using determinants.

14. **GRIDDED RESPONSE** Perry drove to the gym at an average rate of 30 miles per hour. It took him 45 minutes. Going home, he took the same route, but drove at a rate of 45 miles per hour. How many miles is it to his house from the gym?

Extended Response

Record your answers on a sheet of paper. Show your work.

15. Martin is taking a multiple choice test that has 8 questions. Each question has four possible answers: A, B, C, or D. Martin forgot to study for the test, so he must guess at each answer.
- What is the probability of guessing a correct answer on the test?
 - What is the expected number of correct answers if Martin guesses at each question?
 - What is the probability that Martin will get at least half of the questions correct? Round your answer to the nearest tenth of a percent.
16. Christine had one dress and three sweaters cleaned at the dry cleaner and the charge was \$19.50. The next week, she had two dresses and two sweaters cleaned for a total charge of \$23.00.
- Let d represent the price of cleaning a dress and s represent the price of cleaning a sweater. Write a system of linear equations to represent the prices of cleaning each item.
 - Solve the system of equations using substitution or elimination. Explain your choice of method.
 - What will the charge be if Christine takes two dresses and four sweaters to be cleaned?

Need Extra Help?

If you missed Question...

1 2 3 4 5 6 7 8 9 10 11 12 13 14 15 16

Go to Lesson or Page...

12-5 10-1 2-4 5-7 12-2 6-1 7-6 3-1 8-1 11-2 12-1 0-6 4-5 9-5 12-7 3-2

CHAPTER 13

Trigonometric Functions

Then

Throughout this text, you have graphed and analyzed functions.

Now

In Chapter 13, you will:

- Find values of trigonometric functions.
- Solve problems by using right triangle trigonometry.
- Solve triangles by using the Law of Sines and Law of Cosines.
- Graph trigonometric functions.

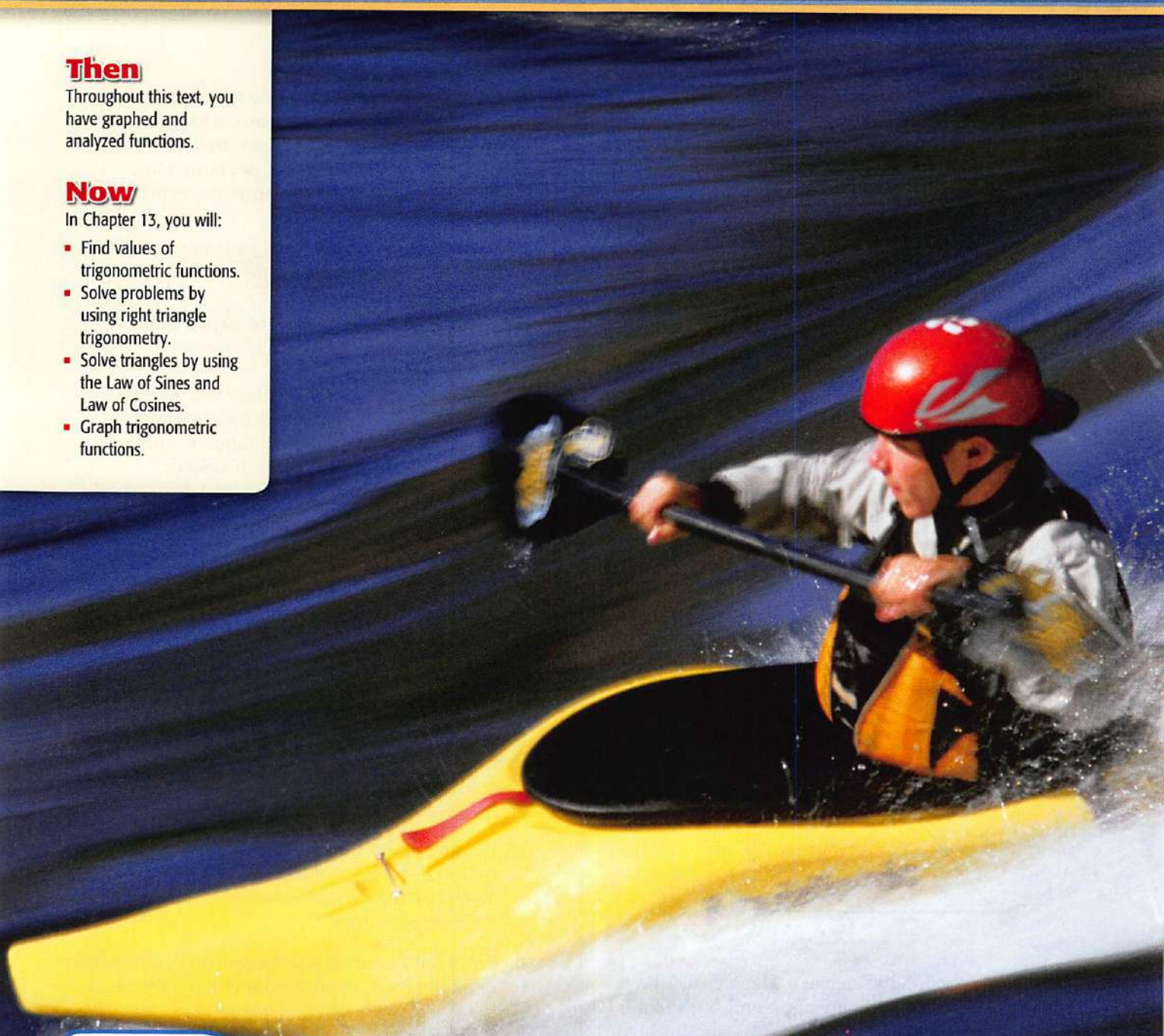

Why?

 **WATER SPORTS** Knowing trigonometric functions has practical applications in water sports. For instance, you can use right triangle trigonometry to find the height of a person parasailing. If you are familiar with angles and angle measures, then you have a better understanding of how impressive it is to be able to do a 540° rotation on a wakeboard.

 **Math in Motion, Animation** glencoe.com

Get Ready for Chapter 13

Diagnose Readiness You have two options for checking Prerequisite Skills.

Text Option

Take the Quick Check below. Refer to the Quick Review for help.

QuickCheck

Find the value of x to the nearest tenth.

(Lesson 0-7)

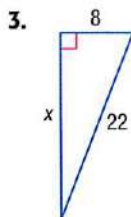
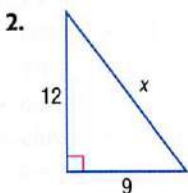
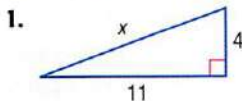

4. Laura has a rectangular garden in her backyard that measures 12 feet by 15 feet. She wants to put a rock walkway on the diagonal. How long will the walkway be? Round to the nearest tenth of a foot.

Find each missing measure. Write all radicals in simplest form. (Geometry)

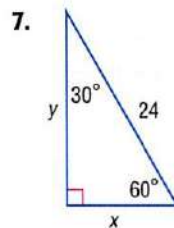
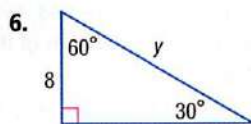
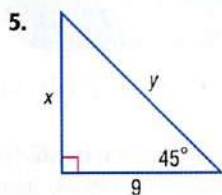

8. A ladder leans against a wall at a 45° angle. If the ladder is 12 feet long, how far up the wall does the ladder reach?

QuickReview

EXAMPLE 1

Find the missing measure of the right triangle.

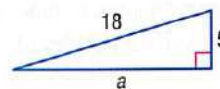

$$c^2 = a^2 + b^2$$

Pythagorean Theorem

$$18^2 = a^2 + 5^2$$

Replace c with 18 and b with 5.

$$324 = a^2 + 25$$

Simplify.

$$299 = a^2$$

Subtract 25 from each side.

$$17.3 \approx a$$

Take the square root of each side.

EXAMPLE 2

Find the missing measures. Write all radicals in simplest form.

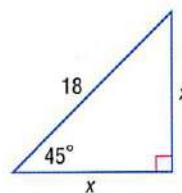

$$x^2 + x^2 = 18^2$$

Pythagorean Theorem

$$2x^2 = 18^2$$

Combine like terms.

$$2x^2 = 324$$

Simplify.

$$x^2 = 162$$

Divide each side by 2.

$$x = \sqrt{162}$$

Take the square root of each side.

$$x = 9\sqrt{2}$$

Simplify.

Online Option

Math Online

Take a self-check Chapter Readiness Quiz at glencoe.com.

Get Started on Chapter 13

You will learn several new concepts, skills, and vocabulary terms as you study Chapter 13. To get ready, identify important terms and organize your resources. You may wish to refer to **Chapter 0** to review prerequisite skills.

FOLDABLES®

Study Organizer

Trigonometric Functions Make this Foldable to help you organize your Chapter 13 notes about trigonometric functions. Begin with four pieces of grid paper.

- 1 **Stack** paper together and measure 2.5 inches from the bottom.

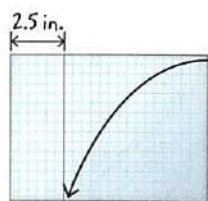

- 2 **Fold** on the diagonal.

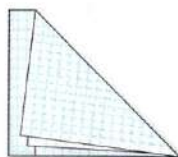

- 3 **Staple** along diagonal to form a book.

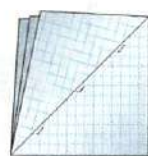

- 4 **Label** edge as Trigonometric Functions.

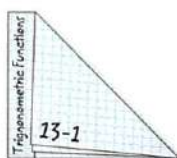

Math Online glencoe.com

- Study the chapter online
- Explore **Math in Motion**
- Get extra help from your own **Personal Tutor**
- Use **Extra Examples** for additional help
- Take a **Self-Check Quiz**
- **Review Vocabulary** in fun ways

New Vocabulary

English	Español
trigonometry	• p. 808 • trigonometría
sine	• p. 808 • seno
cosine	• p. 808 • coseno
tangent	• p. 808 • tangente
cosecant	• p. 808 • cosecante
secant	• p. 808 • secante
cotangent	• p. 808 • cotangente
angle of elevation	• p. 812 • ángulo de depresión
angle of depression	• p. 812 • ángulo de elevación
standard position	• p. 817 • posición estándar
radian	• p. 819 • radián
Law of Sines	• p. 833 • Ley de los senos
Law of Cosines	• p. 841 • Ley de los cosenos
unit circle	• p. 848 • círculo unitario
circular function	• p. 848 • funciones circulares
periodic function	• p. 849 • función periódica
cycle	• p. 849 • ciclo
period	• p. 849 • período
amplitude	• p. 855 • amplitud
frequency	• p. 856 • frecuencia

Review Vocabulary

acute angle • prior course • **ángulo agudo** an angle with a measure between 0° and 90°

function • p. P4 • **función** a relation in which each element of the domain is paired with exactly one element in the range

inverse function • p. 417 • **función inversa** two functions f and g are inverse functions if and only if both of their compositions are the identity function

Pythagorean Theorem • p. P17 • **Teorema de Pitágoras**

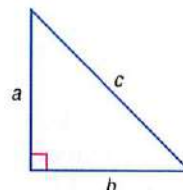

$$a^2 + b^2 = c^2$$

Multilingual eGlossary glencoe.com

Spreadsheet Lab

Investigating Special Right Triangles

You can use a spreadsheet to investigate side measures of special right triangles.

ACTIVITY 45°-45°-90° Triangle

The legs of a 45°-45°-90° triangle, a and b , are equal in measure. What patterns do you observe in the ratios of the side measures of these triangles?

Step 1 Enter the indicated formulas in the spreadsheet. The formula uses the Pythagorean Theorem in the form $c = \sqrt{a^2 + b^2}$.

$$=SQRT(A2^2+B2^2)$$

$$=B2/A2$$

$$=B2/C2$$

$$=A2/C2$$

	A	B	C	D	E	F
1	a	b	c	b/a	b/c	a/c
2	1	1	1.414213562	1	0.707106781	0.707106781
3	2	2	2.828427125	1	0.707106781	0.707106781
4	3	3	4.242640687	1	0.707106781	0.707106781
5	4	4	5.656854249	1	0.707106781	0.707106781

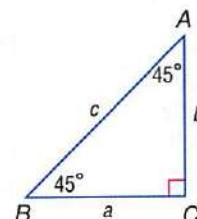

Step 2 Examine the results. Because 45°-45°-90° triangles share the same angle measures, these triangles are all similar. The ratios of the sides of these triangles are all the same. The ratios of side b to side a are 1. The ratios of side b to side c and of side a to side c are approximately 0.71.

Model and Analyze

Use the spreadsheet below for 30°-60°-90° triangles.

	A	B	C	D	E	F
1	a	b	c	b/a	b/c	a/c
2	1		2			
3	2		4			
4	3		6			
5	4		8			

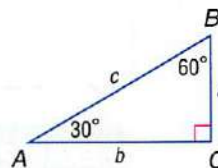

- Copy and complete the spreadsheet above.
- Describe the relationship among the 30°-60°-90° triangles with the dimensions given.
- What patterns do you observe in the ratios of the side measures of these triangles?

Trigonometric Functions in Right Triangles

Then

You used the Pythagorean Theorem to find side lengths of right triangles.

Now

- Find values of trigonometric functions for acute angles.
- Use trigonometric functions to find side lengths and angle measures of right triangles.

New Vocabulary

trigonometry
trigonometric ratio
trigonometric function
sine
cosine
tangent
cosecant
secant
cotangent
reciprocal functions
angle of elevation
angle of depression

Math Online

glencoe.com

- Extra Examples
- Personal Tutor
- Self-Check Quiz
- Homework Help

Why?

The altitude of a person parasailing depends on the length of the tow rope ℓ and the angle the rope makes with the horizontal x° . If you know these two values, you can use a ratio to find the altitude of the person parasailing.

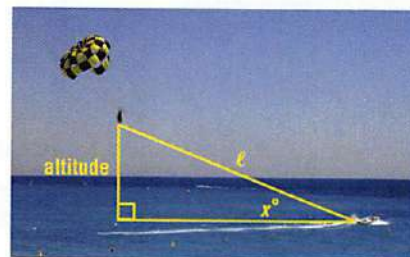

Trigonometric Functions for Acute Angles Trigonometry is the study of relationships among the angles and sides of a right triangle. A **trigonometric ratio** compares the side lengths of a right triangle. A **trigonometric function** has a rule given by a trigonometric ratio.

The Greek letter *theta* θ is often used to represent the measure of an acute angle in a right triangle. The *hypotenuse*, the *leg opposite* θ , and the *leg adjacent* to θ are used to define the six trigonometric functions.

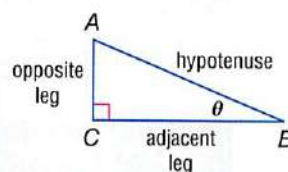

Key Concept

Trigonometric Functions in Right Triangles

For Your

FOLDABLE

Words If θ is the measure of an acute angle of a right triangle, then the following trigonometric functions involving the opposite side *opp*, the adjacent side *adj*, and the hypotenuse *hyp* are true.

Symbols	\sin (sine) $\theta = \frac{\text{opp}}{\text{hyp}}$	\csc (cosecant) $\theta = \frac{\text{hyp}}{\text{opp}}$
	\cos (cosine) $\theta = \frac{\text{adj}}{\text{hyp}}$	\sec (secant) $\theta = \frac{\text{hyp}}{\text{adj}}$
	\tan (tangent) $\theta = \frac{\text{opp}}{\text{adj}}$	\cot (cotangent) $\theta = \frac{\text{adj}}{\text{opp}}$

Examples

$\sin \theta = \frac{4}{5}$	$\cos \theta = \frac{3}{5}$	$\tan \theta = \frac{4}{3}$
$\csc \theta = \frac{5}{4}$	$\sec \theta = \frac{5}{3}$	$\cot \theta = \frac{3}{4}$

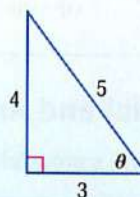

EXAMPLE 1 Evaluate Trigonometric Functions

Find the values of the six trigonometric functions for angle θ .

leg opposite θ : $BC = 8$

leg adjacent θ : $AC = 15$

hypotenuse: $AB = 17$

$$\sin \theta = \frac{\text{opp}}{\text{hyp}} = \frac{8}{17}$$

$$\cos \theta = \frac{\text{adj}}{\text{hyp}} = \frac{15}{17}$$

$$\tan \theta = \frac{\text{opp}}{\text{adj}} = \frac{8}{15}$$

$$\csc \theta = \frac{\text{hyp}}{\text{opp}} = \frac{17}{8}$$

$$\sec \theta = \frac{\text{hyp}}{\text{adj}} = \frac{17}{15}$$

$$\cot \theta = \frac{\text{adj}}{\text{opp}} = \frac{15}{8}$$

Check Your Progress

- Find the values of the six trigonometric functions for angle B .

Personal Tutor glencoe.com

StudyTip

Memorize

Trigonometric Ratios

SOH-CAH-TOA is a mnemonic device for remembering the first letter of each word in the ratios for sine, cosine, and tangent.

$$\sin \theta = \frac{\text{opp}}{\text{hyp}}$$

$$\cos \theta = \frac{\text{adj}}{\text{hyp}}$$

$$\tan \theta = \frac{\text{opp}}{\text{adj}}$$

Notice that the cosecant, secant, and cotangent ratios are reciprocals of the sine, cosine, and tangent ratios, respectively. These are called the **reciprocal functions**. So, the following are also true.

$$\csc \theta = \frac{1}{\sin \theta} \qquad \sec \theta = \frac{1}{\cos \theta} \qquad \cot \theta = \frac{1}{\tan \theta}$$

The domain of any trigonometric function is the set of all acute angles θ of a right triangle. So, trigonometric functions depend only on the measures of the acute angles, not on the side lengths of a right triangle.

EXAMPLE 2 Find Trigonometric Ratios

In a right triangle, $\angle B$ is acute and $\sin B = \frac{5}{8}$. Find the value of $\tan B$.

Step 1 Draw a right triangle and label one acute angle B . Since $\sin B = \frac{5}{8} = \frac{\text{opp}}{\text{hyp}}$, label the opposite side 5 and the hypotenuse 8.

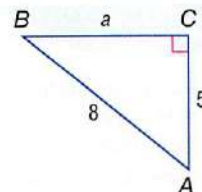

Step 2 Use the Pythagorean Theorem to find a .

$$a^2 + b^2 = c^2$$

$$a^2 + 5^2 = 8^2$$

$$a^2 + 25 = 64$$

$$a^2 = 39$$

$$a = \pm\sqrt{39}$$

$$a = \sqrt{39}$$

Pythagorean Theorem

$$b = 5 \text{ and } c = 8$$

Simplify.

Subtract 25 from each side.

Take the square root of each side.

Length cannot be negative.

Step 3 Find $\tan B$.

$$\tan B = \frac{\text{opp}}{\text{adj}}$$

$$= \frac{5}{\sqrt{39}}$$

$$= \frac{5\sqrt{39}}{39}$$

Tangent function

Replace opp with 5 and adj with $\sqrt{39}$.

Rationalize the denominator.

Check Your Progress

2. If $\tan B = \frac{3}{7}$, find the value of $\sin B$.

Personal Tutor glencoe.com

Angles that measure 30° , 45° , and 60° occur frequently in trigonometry. The table below gives the values of three trigonometric functions for these angles.

ReadingMath

Labeling Triangles

Throughout this chapter, a capital letter is used to represent both a vertex of a triangle and the measure of the angle at that vertex. The same letter in lowercase is used to represent both the side opposite that angle and the length of the side.

Key Concept

Trigonometric Values for Special Angles

For Your
FOLDABLE

30° - 60° - 90°

$$\sin 30^\circ = \frac{1}{2} \qquad \cos 30^\circ = \frac{\sqrt{3}}{2} \qquad \tan 30^\circ = \frac{\sqrt{3}}{3}$$

$$\sin 60^\circ = \frac{\sqrt{3}}{2} \qquad \cos 60^\circ = \frac{1}{2} \qquad \tan 60^\circ = \sqrt{3}$$

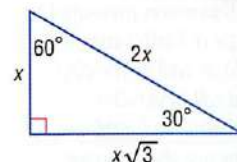

45° - 45° - 90°

$$\sin 45^\circ = \frac{\sqrt{2}}{2} \qquad \cos 45^\circ = \frac{\sqrt{2}}{2} \qquad \tan 45^\circ = 1$$

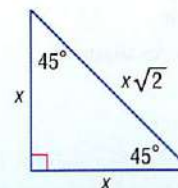

Use Trigonometric Functions You can use trigonometric functions to find missing side lengths and missing angle measures of right triangles.

EXAMPLE 3 Find a Missing Side Length

Use a trigonometric function to find the value of x . Round to the nearest tenth if necessary.

The length of the hypotenuse is 8. The missing measure is for the side adjacent to the 30° angle. Use the cosine function to find x .

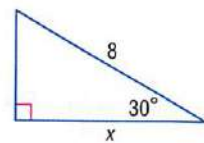

$$\cos \theta = \frac{\text{adj}}{\text{hyp}} \quad \text{Cosine function}$$

$$\cos 30^\circ = \frac{x}{8} \quad \text{Replace } \theta \text{ with } 30^\circ, \text{ adj with } x, \text{ and hyp with } 8.$$

$$\frac{\sqrt{3}}{2} = \frac{x}{8} \quad \cos 30^\circ = \frac{\sqrt{3}}{2}$$

$$\frac{8\sqrt{3}}{2} = x \quad \text{Multiply each side by 8.}$$

$$6.9 \approx x \quad \text{Use a calculator.}$$

StudyTip

Choose a Function

If the length of the hypotenuse is unknown, then either the sine or cosine function must be used to find the missing measure.

Check Your Progress

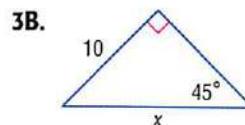
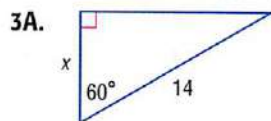

Personal Tutor glencoe.com

You can use a calculator to find the missing side lengths of triangles that do not have 30° , 45° , or 60° angles.

EXAMPLE 4 Find a Missing Side Length

BUILDINGS To calculate the height of a building, Joel walked 200 feet from the base of the building and used an inclinometer to measure the angle from his eye to the top of the building. If his eye level is at 6 feet, how tall is the building?

The measured angle is 76° . The side adjacent to the angle is 200 feet. The missing measure is the side opposite the angle. Use the tangent function to find d .

$$\tan \theta = \frac{\text{opp}}{\text{adj}} \quad \text{Tangent function}$$

$$\tan 76^\circ = \frac{d}{200} \quad \text{Replace } \theta \text{ with } 76^\circ, \text{ opp with } d, \text{ and adj with } 200.$$

$$200 \tan 76^\circ = d \quad \text{Multiply each side by } 200.$$

$$802 \approx d \quad \text{Use a calculator to simplify: } 200 \text{ [TAN] } 76 \text{ [ENTER].}$$

Because the inclinometer was 6 feet above the ground, the height of the building is approximately 808 feet.

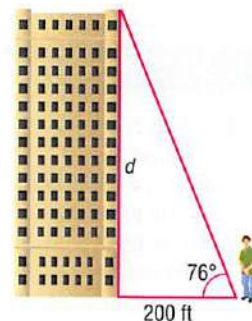

Real-World Link

Inclinometers measure the angle of Earth's magnetic field as well as the pitch and roll of vehicles, sailboats, and airplanes. They are also used for monitoring volcanoes and well drilling.

Source: *Science Magazine*

Check Your Progress

4. Use a trigonometric function to find the value of x . Round to the nearest tenth if necessary.

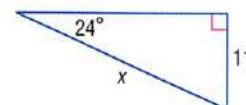

Personal Tutor glencoe.com

When solving equations like $3x = -27$, you use the inverse of multiplication to find x . You also can find angle measures by using the inverse of sine, cosine, or tangent.



Key Concept

Inverse Trigonometric Ratios

For Your
FOLDABLE

Words If $\angle A$ is an acute angle and the sine of A is x , then the **inverse sine** of x is the measure of $\angle A$.

Symbols If $\sin A = x$, then $\sin^{-1} x = m\angle A$.

Example $\sin A = \frac{1}{2} \rightarrow \sin^{-1} \frac{1}{2} = m\angle A \rightarrow m\angle A = 30$

Words If $\angle A$ is an acute angle and the cosine of A is x , then the **inverse cosine** of x is the measure of $\angle A$.

Symbols If $\cos A = x$, then $\cos^{-1} x = m\angle A$.

Example $\cos A = \frac{\sqrt{2}}{2} \rightarrow \cos^{-1} \frac{\sqrt{2}}{2} = m\angle A \rightarrow m\angle A = 45$

Words If $\angle A$ is an acute angle and the tangent of A is x , then the **inverse tangent** of x is the measure of $\angle A$.

Symbols If $\tan A = x$, then $\tan^{-1} x = m\angle A$.

Example $\tan A = \sqrt{3} \rightarrow \tan^{-1} \sqrt{3} = m\angle A \rightarrow m\angle A = 60$

ReadingMath

Inverse Trigonometric Ratios

The expression $\sin^{-1} x$ is read *the inverse sine of x* and is interpreted as the angle whose sine is x . Be careful not to confuse this notation with the notation for negative exponents; $\sin^{-1} x \neq \frac{1}{\sin x}$. Instead, this notation is similar to the notation for an inverse function, $f^{-1}(x)$.

If you know the sine, cosine, or tangent of an acute angle, you can use a calculator to find the measure of the angle, which is the inverse of the trigonometric ratio.

EXAMPLE 5 Find a Missing Angle Measure

Find the measure of each angle. Round to the nearest tenth if necessary.

a. $\angle N$

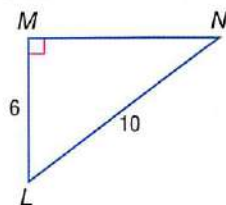

You know the measure of the side opposite $\angle N$ and the measure of the hypotenuse. Use the sine function.

$$\begin{aligned} \sin N &= \frac{6}{10} & \sin \theta &= \frac{\text{opp}}{\text{hyp}} \\ \sin^{-1} \frac{6}{10} &= m\angle N & \text{Inverse sine} & \\ 36.9 &\approx m\angle N & \text{Use a calculator.} & \end{aligned}$$

b. $\angle B$

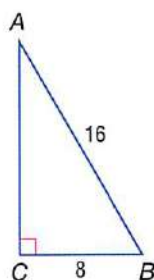

Use the cosine function.

$$\begin{aligned} \cos B &= \frac{8}{16} & \cos \theta &= \frac{\text{adj}}{\text{hyp}} \\ \cos^{-1} \frac{8}{16} &= m\angle B & \text{Inverse cosine} & \\ 60 &= m\angle B & \text{Use a calculator.} & \end{aligned}$$

Check Your Progress

Find x . Round to the nearest tenth if necessary.

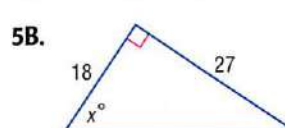
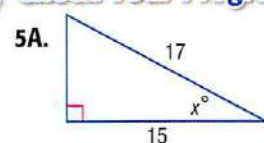

StudyTip

Angles of Elevation and Depression The angle of elevation and the angle of depression are congruent since they are alternate interior angles of parallel lines.

In the figure at the right, the angle formed by the line of sight from the swimmer and a line parallel to the horizon is called the **angle of elevation**. The angle formed by the line of sight from the lifeguard and a line parallel to the horizon is called the **angle of depression**.



EXAMPLE 6 Use Angles of Elevation and Depression

- a. GOLF** A golfer is standing at the tee, looking up to the green on a hill. If the tee is 36 yards lower than the green and the angle of elevation from the tee to the hole is 12° , find the distance from the tee to the hole.

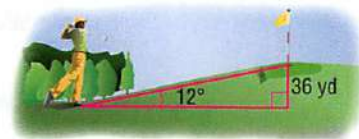

Write an equation using a trigonometric function that involves the ratio of the vertical rise (side opposite the 12° angle) and the distance from the tee to the hole (hypotenuse).

$$\sin 12^\circ = \frac{36}{x}$$

$$\sin \theta = \frac{\text{opp}}{\text{hyp}}$$

$$x \sin 12^\circ = 36$$

Multiply each side by x .

$$x = \frac{36}{\sin 12^\circ}$$

Divide each side by $\sin 12^\circ$.

$$x \approx 173.2$$

Use a calculator.

So, the distance from the tee to the hole is about 173.2 yards.

- b. ROLLER COASTER** The hill of the roller coaster has an *angle of descent*, or an angle of depression, of 60° . Its vertical drop is 195 feet. Estimate the length of the hill.

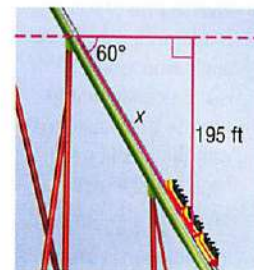

Write an equation using a trigonometric function that involves the ratio of the vertical drop (side opposite the 60° angle) and the length of the hill (hypotenuse).

$$\sin 60^\circ = \frac{195}{x}$$

$$\sin \theta = \frac{\text{opp}}{\text{hyp}}$$

$$x \sin 60^\circ = 195$$

Multiply each side by x .

$$x = \frac{195}{\sin 60^\circ}$$

Divide each side by $\sin 60^\circ$.

$$x \approx 225.2$$

Use a calculator.

So, the length of the hill is about 225.2 feet.



Real-World Link

The steepest roller coasters in the world have angles of descent that are close to 90° .

Source: Ultimate Roller Coaster

Check Your Progress

- 6A. MOVING** A ramp for unloading a moving truck has an angle of elevation of 32° . If the top of the ramp is 4 feet above the ground, estimate the length of the ramp.



- 6B. LADDERS** A 14-ft long ladder is placed against a house at an angle of elevation of 72° . How high above the ground is the top of the ladder?

Check Your Understanding

Example 1 p. 808

Find the values of the six trigonometric functions for angle θ .

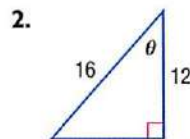
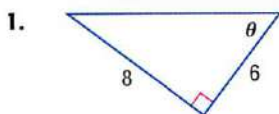

Example 2 p. 809

In a right triangle, $\angle A$ is acute.

3. If $\cos A = \frac{4}{7}$, what is $\sin A$?

4. If $\tan A = \frac{20}{21}$, what is $\cos A$?

Examples 3 and 4 p. 810

Use a trigonometric function to find the value of x . Round to the nearest tenth.

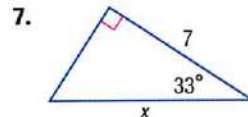
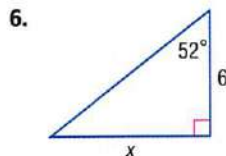
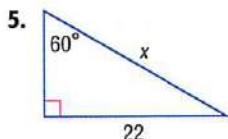

Example 5 p. 811

Find the value of x . Round to the nearest tenth.

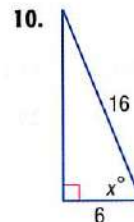
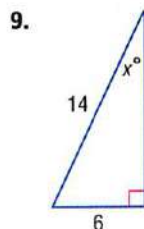
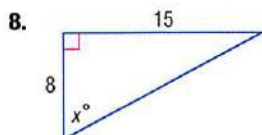

Example 6 p. 812

11. **GEOGRAPHY** Christian found two trees directly across from each other in a canyon. When he moved 100 feet from the tree on his side (parallel to the edge of the canyon), the angle formed by the tree on his side, Christian, and the tree on the other side was 70° . Find the distance across the canyon.
12. **LADDERS** The recommended angle of elevation for a ladder used in fire fighting is 75° . At what height on a building does a 21-foot ladder reach if the recommended angle of elevation is used? Round to the nearest tenth.

 = **Step-by-Step Solutions** begin on page R20.
Extra Practice begins on page 947.

Practice and Problem Solving

Example 1 p. 808

Find the values of the six trigonometric functions for angle θ .

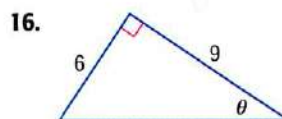
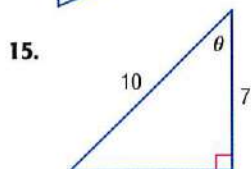
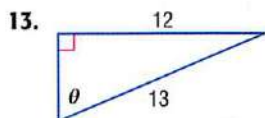

Example 2 p. 809

In a right triangle, $\angle A$ and $\angle B$ are acute.

17. If $\tan A = \frac{8}{15}$, what is $\cos A$?

18. If $\cos A = \frac{3}{10}$, what is $\tan A$?

19. If $\tan B = 3$, what is $\sin B$?

20. If $\sin B = \frac{4}{9}$, what is $\tan B$?

Examples 3 and 4

p. 810

Use a trigonometric function to find each value of x . Round to the nearest tenth.

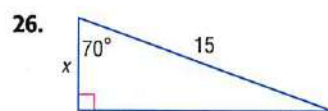
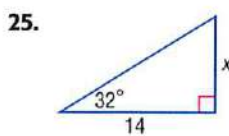
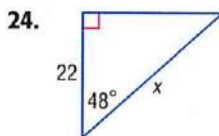
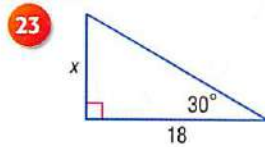
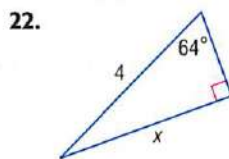
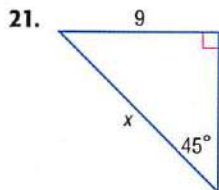

27. **PARASAILING** Refer to the beginning of the lesson and the figure at the right. Find a , the altitude of a person parasailing, if the tow rope is 250 feet long and the angle formed is 32° . Round to the nearest tenth.

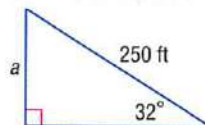

28. **BRIDGES** Devon wants to build a rope bridge between his treehouse and Cheng's treehouse. Suppose Devon's treehouse is directly behind Cheng's treehouse. At a distance of 20 meters to the left of Devon's treehouse, an angle of 52° is measured between the two treehouses. Find the length of the rope.

Example 5

p. 811

Find the value of x . Round to the nearest tenth.

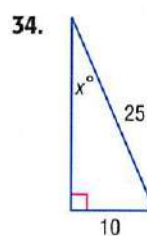
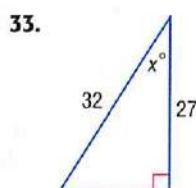
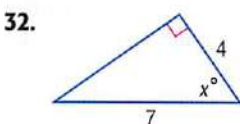
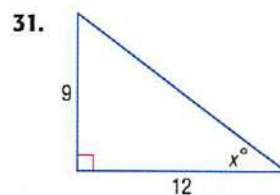
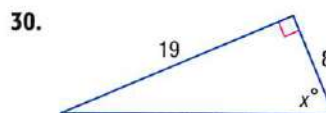
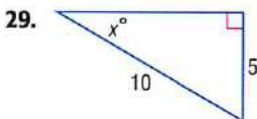

Example 6

p. 812

35. **SQUIRRELS** Adult flying squirrels can make glides of up to 160 feet. If a flying squirrel glides a horizontal distance of 160 feet and the angle of descent is 9° , find its change in height.

36. **HANG GLIDING** A hang glider climbs at a 20° angle of elevation. Find the change in altitude of the hang glider when it has flown a horizontal distance of 60 feet.

Use trigonometric functions to find the values of x and y . Round to the nearest tenth.

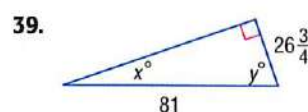
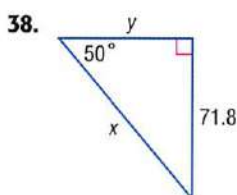
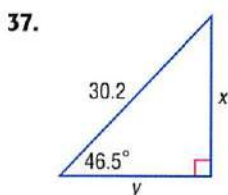

Solve each equation.

40. $\cos a = \frac{3}{19}$

41. $\sin n = \frac{9}{11}$

42. $\tan x = 15$

43. $\sin t = 0.35$

44. $\tan g = 0.125$

45. $\cos z = 0.98$

46. **MONUMENTS** A monument casts a shadow 24 feet long. The angle of elevation from the end of the shadow to the top of the monument is 50° .
- Draw and label a right triangle to represent this situation.
 - Write a trigonometric function that can be used to find the height of the monument.
 - Find the value of the function to determine the height of the monument to the nearest tenth.

47. **NESTS** Tabitha's eyes are 5 feet above the ground as she looks up to a bird's nest in a tree. If the angle of elevation is 74.5° and she is standing 12 feet from the tree's base, what is the height of the bird's nest? Round to the nearest foot.

48. **RAMPS** Two bicycle ramps each cover a horizontal distance of 8 feet. One ramp has a 20° angle of elevation, and the other ramp has a 35° angle of elevation, as shown at the right.

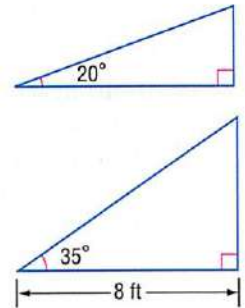

- How much taller is the second ramp than the first? Round to the nearest tenth.
- How much longer is the second ramp than the first? Round to the nearest tenth.

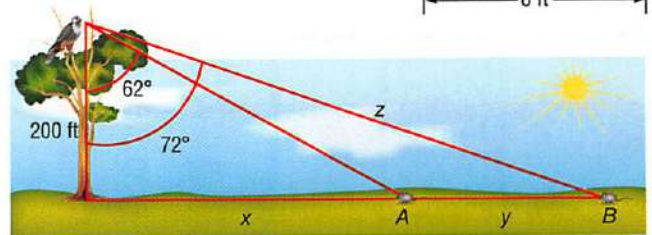

49. **FALCONS** A falcon at a height of 200 feet sees two mice A and B , as shown in the diagram.

- What is the approximate distance z between the falcon and mouse B ?
- How far apart are the two mice?



Real-World Link

A falcon can see an object 10 centimeters long from a distance of 1.5 kilometers away. A falcon can also see sharp images when diving at 100 miles per hour.

Source: Neuroscience for Kids

In $\triangle ABC$, $\angle C$ is a right angle. Use the given measurements to find the missing side lengths and missing angle measures of $\triangle ABC$. Round to the nearest tenth if necessary.

50. $m\angle A = 36^\circ$, $a = 12$

51. $m\angle B = 31^\circ$, $b = 19$

52. $a = 8$, $c = 17$

53. $\tan A = \frac{4}{5}$, $a = 6$

H.O.T. Problems

Use Higher-Order Thinking Skills

54. **CHALLENGE** A line segment has endpoints $A(2, 0)$ and $B(6, 5)$, as shown in the figure at the right. What is the measure of the acute angle θ formed by the line segment and the x -axis? Explain how you found the measure.

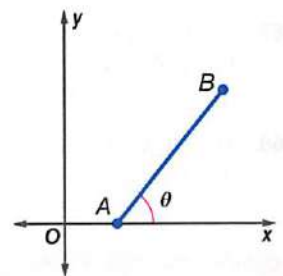

55. **REASONING** Determine whether the following statement is true or false. Explain your reasoning.

For any acute angle, the sine function will never have a negative value.

56. **OPEN ENDED** In right triangle ABC , $\sin A = \sin C$. What can you conclude about $\triangle ABC$? Justify your reasoning.

57. **WRITING IN MATH** A roof has a slope of $\frac{2}{3}$. Describe the connection between the slope and the angle of elevation θ that the roof makes with the horizontal. Then use an inverse trigonometric function to find θ .

Standardized Test Practice

- 58. EXTENDED RESPONSE** Your school needs 5 cases of yearbooks. Neighborhood Yearbooks lists a case of yearbooks at \$153.85 with a 10% discount on an order of 5 cases. Yearbooks R Us lists a case of yearbooks at \$157.36 with a 15% discount on 5 cases.
- Which company would you choose?
 - What is the least amount that you would have to spend for the yearbooks?
- 59. SHORT RESPONSE** As a fundraiser, the marching band sold T-shirts and hats. They sold a total of 105 items and raised \$1170. If the cost of a hat was \$10 and the cost of a T-shirt was \$15, how many T-shirts were sold?
- 60.** A hot dog stand charges price x for a hot dog and price y for a drink. Two hot dogs and one drink cost \$4.50. Three hot dogs and two drinks cost \$7.25. Which matrix could be multiplied by $\begin{bmatrix} 4.50 \\ 7.25 \end{bmatrix}$ to find x and y ?
- A $\begin{bmatrix} -1 & 1 \\ 2 & -1 \end{bmatrix}$ C $\begin{bmatrix} 1 & 2 \\ -1 & 3 \end{bmatrix}$
- B $\begin{bmatrix} 2 & -1 \\ -3 & 2 \end{bmatrix}$ D $\begin{bmatrix} 1 & -1 \\ -1 & 2 \end{bmatrix}$
- 61. SAT/ACT** The length and width of a rectangle are in the ratio of 5:12. If the rectangle has an area of 240 square centimeters, what is the length, in centimeters, of its diagonal?
- F 26 H 30
G 28 J 32

Spiral Review

- 62. POLLS** A polling company wants to estimate how many people are in favor of a new environmental law. The polling company polls 20 people. The probability that a person is in favor of the law is 0.5. (Lesson 12-7)
- What is the probability that exactly 12 people are in favor of the new law?
 - What is the expected number of people in favor of the law?

Text each null hypothesis. Write *accept* or *reject*. (Lesson 12-6)

63. $H_0 = 92, H_1 > 92, n = 80, \bar{x} = 92.75,$ and $s = 2.8$
64. $H_0 = 48, H_1 > 48, n = 240, \bar{x} = 48.2,$ and $s = 2.2$
65. $H_0 = 71, H_1 > 71, n = 180, \bar{x} = 72.4,$ and $s = 3.5$
66. $H_0 = 55, H_1 < 55, n = 300, \bar{x} = 54.5,$ and $s = 1.9$

Find each probability. (Lesson 12-4)

67. A city council consists of six Democrats, two of whom are women, and six Republicans, four of whom are men. A member is chosen at random. If the member chosen is a man, what is the probability that he is a Democrat?
68. Two boys and two girls are lined up at random. What is the probability that the girls are separated if a girl is on an end?

Skills Review

Find each product. Include the appropriate units with your answer. (Lesson 6-1B)

69. $4.3 \text{ miles} \left(\frac{5280 \text{ feet}}{1 \text{ mile}} \right)$ 70. $8 \text{ gallons} \left(\frac{8 \text{ pints}}{1 \text{ gallon}} \right)$ 71. $\left(\frac{5 \text{ dollars}}{3 \text{ meters}} \right) 21 \text{ meters}$
72. $\left(\frac{18 \text{ cubic inches}}{5 \text{ seconds}} \right) 24 \text{ seconds}$ 73. $65 \text{ degrees} \left(\frac{10 \text{ centimeters}}{3 \text{ degrees}} \right)$ 74. $\left(\frac{7 \text{ liters}}{30 \text{ minutes}} \right) 10 \text{ minutes}$

Angles and Angle Measure

Then

You used angles with degree measures.
(Lesson 13-1)

Now

- Draw and find angles in standard position.
- Convert between degree measures and radian measures.

New Vocabulary

standard position
initial side
terminal side
coterminal angles
radian
central angle

Math Online

glencoe.com

- Extra Examples
- Personal Tutor
- Self-Check Quiz
- Homework Help
- Math in Motion

Why?

A sundial is an instrument that indicates the time of day by the shadow that it casts on a surface marked to show hours or fractions of hours. The shadow moves around the dial 15° every hour.



Angles in Standard Position An angle on the coordinate plane is in **standard position** if the vertex is at the origin and one ray is on the positive x -axis.

- The ray on the x -axis is called the **initial side** of the angle.
- The ray that rotates about the center is called the **terminal side**.

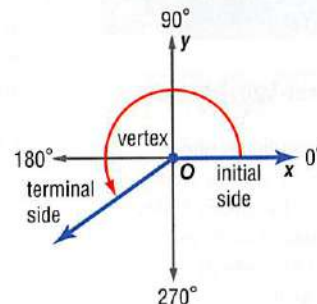

Key Concept

Angle Measures

For Your
FOLDABLE

If the measure of an angle is positive, the terminal side is rotated counterclockwise.

If the measure of an angle is negative, the terminal side is rotated clockwise.

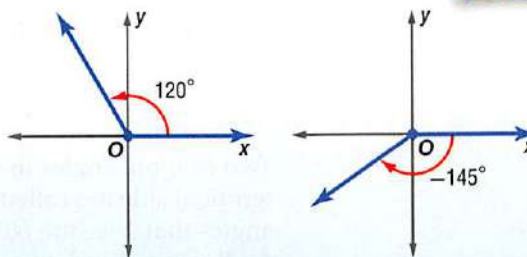

Math in Motion, Animation glencoe.com

EXAMPLE 1 Draw an Angle in Standard Position

Draw an angle with the given measure in standard position.

a. 215° $215^\circ = 180^\circ + 35^\circ$

Draw the terminal side of the angle 35° counterclockwise past the negative x -axis.

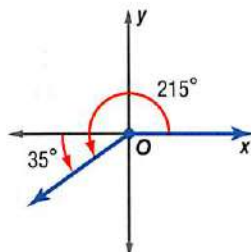

b. -40°

The angle is negative. Draw the terminal side of the angle 40° clockwise from the positive x -axis.

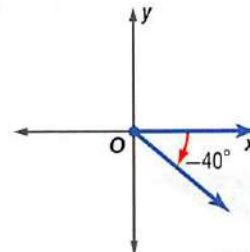

Check Your Progress

1A. 80°

1B. -105°

Personal Tutor glencoe.com

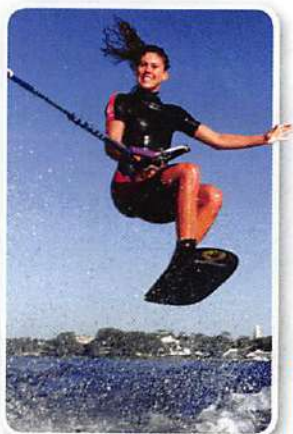

The terminal side of an angle can make more than one complete rotation. For example, a complete rotation of 360° plus a rotation of 120° forms an angle that measures $360^\circ + 120^\circ$ or 480° .

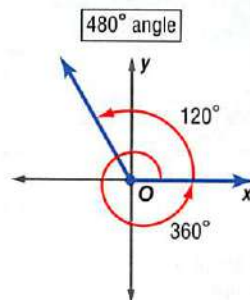

Real-World Link

Wakeboarding is one of the fastest-growing water sports in the United States. Participation increased more than 100% in recent years.

Source: King of Wake

Real-World EXAMPLE 2 Draw an Angle in Standard Position

WAKEBOARDING Wakeboarding is a combination of surfing, skateboarding, snowboarding, and water skiing. One maneuver involves a 540-degree rotation in the air. Draw an angle in standard position that measures 540° .

$$540^\circ = 360^\circ + 180^\circ$$

Draw the terminal side of the angle 180° past the positive x -axis.

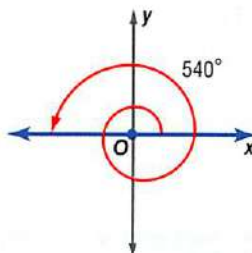

Check Your Progress

- Draw an angle in standard position that measures 600° .

Personal Tutor glencoe.com

Two or more angles in standard position with the same terminal side are called **coterminal angles**. For example, angles that measure 60° , 420° , and -300° are coterminal, as shown in the figure at the right.

An angle that is coterminal with another angle can be found by adding or subtracting a multiple of 360° .

- $60^\circ + 360^\circ = 420^\circ$
- $60^\circ - 360^\circ = -300^\circ$

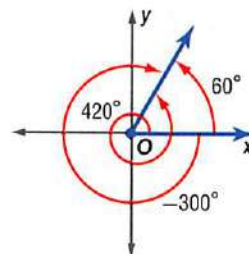

EXAMPLE 3 Find Coterminal Angles

Find an angle with a positive measure and an angle with a negative measure that are coterminal with each angle.

- 130°

positive angle: $130^\circ + 360^\circ = 490^\circ$

Add 360° .

negative angle: $130^\circ - 360^\circ = -230^\circ$

Subtract 360° .

- -200°

positive angle: $-200^\circ + 360^\circ = 160^\circ$

Add 360° .

negative angle: $-200^\circ - 360^\circ = -560^\circ$

Subtract 360° .

Check Your Progress

- 15°

- -45°

Personal Tutor glencoe.com

ReadingMath

Angle of Rotation

In trigonometry, an angle is sometimes referred to as an *angle of rotation*.

StudyTip

Radians As with degrees, radians measure the amount of rotation from the initial side to the terminal side.

- The measure of an angle in radians is positive if its rotation is counterclockwise.
- The measure is negative if the rotation is clockwise.

Convert Between Degrees and Radians Angles can also be measured in units that are based on arc length. One **radian** is the measure of an angle θ in standard position with a terminal side that intercepts an arc with the same length as the radius of the circle.

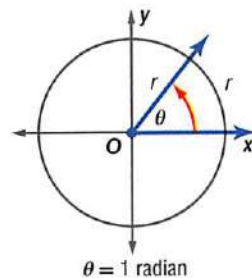

The circumference of a circle is $2\pi r$. So, one complete revolution around a circle equals 2π radians. Since 2π radians = 360° , degree measure and radian measure are related by the following equations.

$$2\pi \text{ radians} = 360^\circ \quad \pi \text{ radians} = 180^\circ$$

Key Concept

Convert Between Degrees and Radians

For Your **FOLDABLE**

Degrees to Radians

To convert from degrees to radians, multiply the number of degrees by

$$\frac{\pi \text{ radians}}{180^\circ}$$

Radians to Degrees

To convert from radians to degrees, multiply the number of radians by

$$\frac{180^\circ}{\pi \text{ radians}}$$

Math in Motion, Interactive Lab glencoe.com

ReadingMath

Radian Measures

The word *radian* is usually omitted when angles are expressed in radian measure. Thus, when no units are given for an angle measure, radian measure is implied.

EXAMPLE 4 Convert Between Degrees and Radians

Rewrite the degree measure in radians and the radian measure in degrees.

a. -30°

$$\begin{aligned} -30^\circ &= -30^\circ \cdot \frac{\pi \text{ radians}}{180^\circ} \\ &= \frac{-30\pi}{180} \text{ or } -\frac{\pi}{6} \text{ radians} \end{aligned}$$

b. $\frac{5\pi}{2}$

$$\begin{aligned} \frac{5\pi}{2} &= \frac{5\pi}{2} \text{ radians} \cdot \frac{180^\circ}{\pi \text{ radians}} \\ &= \frac{900^\circ}{2} \text{ or } 450^\circ \end{aligned}$$

Check Your Progress

4A. 120°

4B. $-\frac{3\pi}{8}$

Personal Tutor glencoe.com

Concept Summary

Degrees and Radians

For Your **FOLDABLE**

The diagram shows equivalent degree and radian measures for special angles.

You may find it helpful to memorize the following equivalent degree and radian measures. The other special angles are multiples of these angles.

$$\begin{aligned} 30^\circ &= \frac{\pi}{6} & 45^\circ &= \frac{\pi}{4} \\ 60^\circ &= \frac{\pi}{3} & 90^\circ &= \frac{\pi}{2} \end{aligned}$$

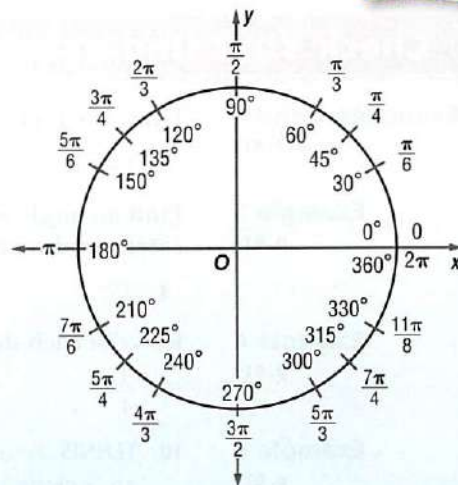

A **central angle** of a circle is an angle with a vertex at the center of the circle. If you know the measure of a central angle and the radius of the circle, you can find the length of the arc that is intercepted by the angle.

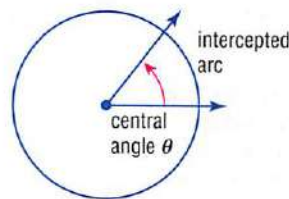

Key Concept

Arc Length

For Your
FOLDABLE

Words For a circle with radius r and central angle θ (in radians), the arc length s equals the product of r and θ .

Model

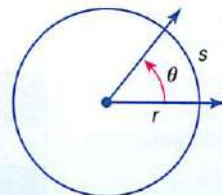

Symbols $s = r\theta$

You will justify this formula in Exercise 52.



Real-World EXAMPLE 5 Find Arc Length

TRUCKS Monster truck tires have a radius of 33 inches. How far does a monster truck travel in feet after just three fourths of a tire rotation?

Step 1 Find the central angle in radians.

$$\theta = \frac{3}{4} \cdot 2\pi \text{ or } \frac{3\pi}{2} \quad \text{The angle is } \frac{3}{4} \text{ of a complete rotation.}$$

Step 2 Use the radius and central angle to find the arc length.

$$\begin{aligned} s &= r\theta && \text{Write the formula for arc length.} \\ &= 33 \cdot \frac{3\pi}{2} && \text{Replace } r \text{ with 33 and } \theta \text{ with } \frac{3\pi}{2}. \\ &\approx 155.5 \text{ in.} && \text{Use a calculator to simplify.} \\ &\approx 13.0 \text{ ft} && \text{Divide by 12 to convert to feet.} \end{aligned}$$

So, the truck travels about 13 feet after three fourths of a tire rotation.



Check Your Progress

5. A circle has a diameter of 9 centimeters. Find the arc length if the central angle is 60° . Round to the nearest tenth.



Personal Tutor glencoe.com



Check Your Understanding

Examples 1 and 2
pp. 817–818

Draw an angle with the given measure in standard position.

1. 140°

2. -60°

3. 390°

Example 3
p. 818

Find an angle with a positive measure and an angle with a negative measure that are coterminal with each angle.

4. 25°

5. 175°

6. -100°

Example 4
p. 819

Rewrite each degree measure in radians and each radian measure in degrees.

7. $\frac{\pi}{4}$

8. 225°

9. -40°

Example 5
p. 820

10. **TENNIS** A tennis player's swing moves along the path of an arc. If the radius of the arc's circle is 4 feet and the angle of rotation is 100° , what is the length of the arc? Round to the nearest tenth.

Practice and Problem Solving

= **Step-by-Step Solutions** begin on page R20.
Extra Practice begins on page 947.

Examples 1 and 2

pp. 817–818

Draw an angle with the given measure in standard position.

11. 75° 12. 160° 13. -90°
 14. -120° 15. 295° 16. 510°

17. **GYMNASTICS** A gymnast on the uneven bars swings to make a 240° angle of rotation.
 18. **FOOD** The lid on a jar of pasta sauce is turned 420° before it comes off.

Example 3

p. 818

Find an angle with a positive measure and an angle with a negative measure that are coterminal with each angle.

19. 50° 20. 95° 21. 205°
 22. 350° 23. -80° 24. -195°

Example 4

p. 819

Rewrite each degree measure in radians and each radian measure in degrees.

25. 330° 26. $\frac{5\pi}{6}$ 27. $-\frac{\pi}{3}$
 28. -50° 29. 190° 30. $-\frac{7\pi}{3}$

Example 5

p. 820

31. **SKATEBOARDING** The skateboard ramp at the right is called a *quarter pipe*. The curved surface is determined by the radius of a circle. Find the length of the curved part of the ramp.
 32. **RIVERBOATS** The paddlewheel of a riverboat has a diameter of 24 feet. Find the arc length of the circle made when the paddlewheel rotates 300° .

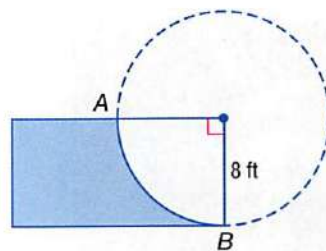

Find the length of each arc. Round to the nearest tenth.

33.

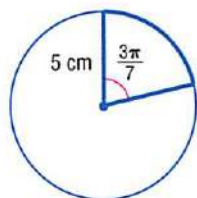

34.

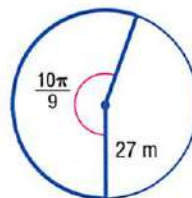

35. **CLOCKS** How long does it take for the minute hand on a clock to pass through 2.5π radians?
 36. **SUNDIALS** Refer to the beginning of the lesson. A shadow moves around a sundial 15° every hour.
 a. After how many hours is the angle of rotation of the shadow $\frac{8\pi}{5}$ radians?
 b. What is the angle of rotation in radians after 5 hours?
 c. A sundial has a radius of 8 inches. What is the arc formed by a shadow after 14 hours? Round to the nearest tenth.



Real-World Link

The Sundial Bridge at Turtle Bay in Redding, California, is the world's largest sundial. It is 700 feet long, 23 feet wide, and 217 feet high.

Source: Turtle Bay Exploration Park

Find an angle with a positive measure and an angle with a negative measure that are coterminal with each angle.

37. 620° 38. -400° 39. $-\frac{3\pi}{4}$ 40. $\frac{19\pi}{6}$

- 41. SWINGS** A swing has a 165° angle of rotation.
- Draw the angle in standard position.
 - Write the angle measure in radians.
 - If the chains of the swing are $6\frac{1}{2}$ feet long, what is the length of the arc that the swing makes? Round to the nearest tenth.
 - Describe how the arc length would change if the lengths of the chains of the swing were doubled.
- 42. MULTIPLE REPRESENTATIONS** Consider $A(-4, 0)$, $B(-4, 6)$, $C(6, 0)$, and $D(6, 8)$.
- GEOMETRIC** Draw $\triangle EAB$ and $\triangle ECD$ with E at the origin.
 - ALGEBRAIC** Find the values of the tangent of $\angle BEA$ and the tangent of $\angle DEC$.
 - ALGEBRAIC** Find the slope of \overline{BE} and \overline{ED} .
 - VERBAL** What conclusions can you make about the relationship between slope and tangent?

Rewrite each degree measure in radians and each radian measure in degrees.

43. $\frac{21\pi}{8}$ 44. 124° 45. -200° 46. 5

- 47. CAROUSELS** A carousel makes 5 revolutions per minute. The circle formed by riders sitting in the outside row has a radius of 17.2 feet. The circle formed by riders sitting in the inside row has a radius of 13.1 feet.
- Find the angle θ in radians through which the carousel rotates in one second.
 - In one second, what is the difference in arc lengths between the riders sitting in the outside row and the riders sitting in the inside row?

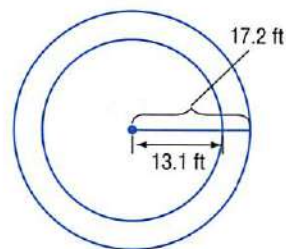

Real-World Link

In the United States, carousels rotate counterclockwise, while carousels in Europe rotate clockwise.

Source: The Discovery Channel

H.O.T. Problems

Use Higher-Order Thinking Skills

- 48. FIND THE ERROR** Tarshia and Alan are writing an expression for the measure of an angle coterminal with the angle shown at the right. Is either of them correct? Explain your reasoning.

Tarshia
The measure of a coterminal angle is $(x - 360)^\circ$.

Alan
The measure of a coterminal angle is $(360 - x)^\circ$.

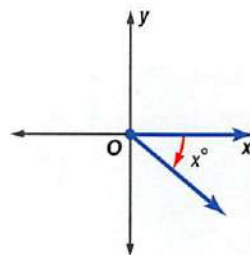

- 49. CHALLENGE** A line makes an angle of $\frac{\pi}{2}$ radians with the positive x -axis at the point $(2, 0)$. Find an equation for this line.
- 50. REASONING** Express $\frac{1}{8}$ of a revolution in degrees and in radians. Explain your reasoning.
- 51. OPEN ENDED** Draw and label an acute angle in standard position. Find two angles, one positive and one negative, that are coterminal with the angle.
- 52. REASONING** Justify the formula for the length of an arc.
- 53. WRITING IN MATH** Use a circle with radius r to describe what one degree and one radian represent. Then explain how to convert between the measures.

Standardized Test Practice

54. **SHORT RESPONSE** If $(x + 6)(x + 8) - (x - 7)(x - 5) = 0$, find x .
55. Which of the following represents an inverse variation?

A

x	2	5	10	20	25	50
y	50	20	10	5	4	2

B

x	2	4	6	8	10	12
y	-4	-8	-12	-16	-20	-24

C

x	1	2	3	4	5	6
y	5	10	15	20	25	30

D

x	10	9	8	7	6	5
y	5	6	7	8	9	10

56. **GEOMETRY** If the area of the figure is 60 square units, what is the length of side \overline{XZ} ?

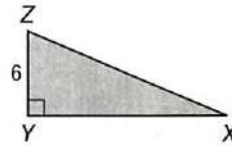

- F $2\sqrt{34}$ H $4\sqrt{109}$
 G $2\sqrt{109}$ J $4\sqrt{34}$

57. **SAT/ACT** The first term of a sequence is -6 , and every term after the first is 8 more than the term immediately preceding it. What is the value of the 101st term?

- A 788 C 802
 B 794 D 808

Spiral Review

Find the values of the six trigonometric functions for angle θ . (Lesson 13-1)

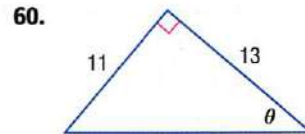
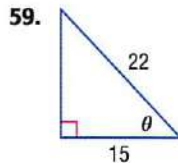

A binomial distribution has a 40% rate of success. There are 12 trials. (Lesson 12-7)

61. What is the probability that there will be at least 8 successes? exactly 5 failures?
62. What is the expected number of successes?
63. **MANUFACTURING** The sizes of CDs made by a company are normally distributed with a standard deviation of 1 millimeter. The CDs are supposed to be 120 millimeters in diameter, and they are made for drives that are 122 millimeters wide. (Lesson 12-5)
- What percent of the CDs would you expect to be greater than 120 millimeters?
 - If the company manufactures 1000 CDs per hour, how many of the CDs made in one hour would you expect to be between 119 and 122 millimeters?
 - About how many CDs per hour will be too large to fit in the drives?
64. **FINANCIAL LITERACY** If the rate of inflation is 2%, the cost of an item in future years can be found by iterating the function $c(x) = 1.02x$. Find the cost of a \$70 digital audio player in four years if the rate of inflation remains constant. (Lesson 11-5)

Skills Review

Use the Pythagorean Theorem to find the length of the hypotenuse for each right triangle with the given side lengths. (Lesson 0-7)

65. $a = 12, b = 15$

66. $a = 8, b = 17$

67. $a = 14, b = 11$

The area of any triangle can be found using the sine ratios in the triangle. A similar process can be used to find the area of a parallelogram.

ACTIVITY

Find the area of parallelogram $ABCD$.

Step 1 Draw diagonal \overline{BD} .
 \overline{BD} divides the parallelogram into two congruent triangles, $\triangle ABD$ and $\triangle CDB$.

Step 2 Find the area of $\triangle ABD$.

$$\begin{aligned} \text{Area} &= \frac{1}{2}(AB)(AD) \sin A && \text{Area of a triangle} \\ &= \frac{1}{2}(16)(28) \sin 60^\circ && AB = 16, AD = 28, \text{ and } A = 60^\circ \\ &= 224 \left(\frac{\sqrt{3}}{2} \right) && \text{Multiply and evaluate } \sin 60^\circ. \\ &= 112\sqrt{3} && \text{Simplify.} \end{aligned}$$

Step 3 Find the area of $\square ABCD$.

The area of $\square ABCD$ is equal to the sum of the areas of $\triangle ABD$ and $\triangle CDB$. Because $\triangle ABD \cong \triangle CDB$, the areas of $\triangle ABD$ and $\triangle CDB$ are equal. So, the area of $\square ABCD$ equals twice the area of $\triangle ABD$.

$$2 \cdot 112\sqrt{3} = 224\sqrt{3} \text{ or about } 387.98 \text{ square inches.}$$

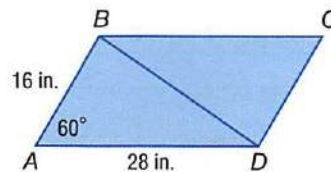
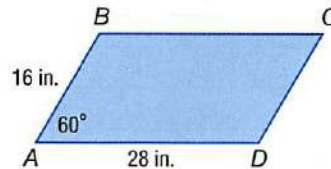

Exercises

For each of the following,

- find the area of each parallelogram.
- find the area of each parallelogram when the included angle is half the given measure.
- find the area of each parallelogram when the included angle is twice the given measure.

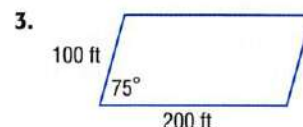
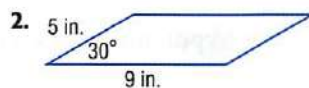
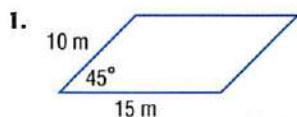

Trigonometric Functions of General Angles

Then

You found values of trigonometric functions for acute angles. (Lesson 13-1)

Now

- Find values of trigonometric functions for general angles.
- Find values of trigonometric functions by using reference angles.

New Vocabulary

quadrantal angle
reference angle

Math Online

glencoe.com

- Extra Examples
- Personal Tutor
- Self-Check Quiz
- Homework Help
- Math in Motion

Why?

In the ride at the right, the cars rotate back and forth about a central point. The current positions of two of the arms can be described as 220° clockwise and 50° counterclockwise from the standard position.

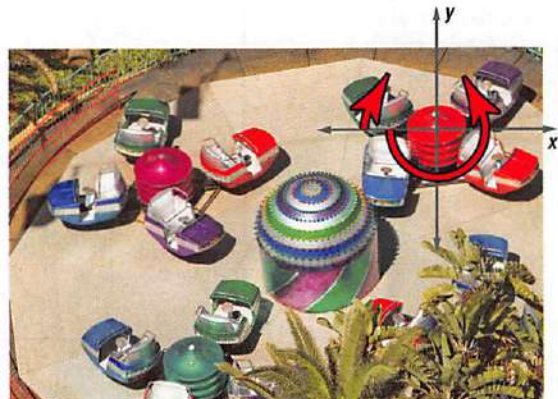

Trigonometric Functions for General Angles You can find values of trigonometric functions for angles greater than 90° or less than 0° .

Key Concept

Trigonometric Functions of General Angles

Let θ be an angle in standard position and let $P(x, y)$ be a point on its terminal side. Using the Pythagorean Theorem, $r = \sqrt{x^2 + y^2}$. The six trigonometric functions of θ are defined below.

$$\begin{aligned} \sin \theta &= \frac{y}{r} & \cos \theta &= \frac{x}{r} & \tan \theta &= \frac{y}{x}, x \neq 0 \\ \csc \theta &= \frac{r}{y}, y \neq 0 & \sec \theta &= \frac{r}{x}, x \neq 0 & \cot \theta &= \frac{x}{y}, y \neq 0 \end{aligned}$$

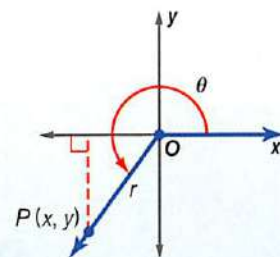

For Your
FOLDABLE

EXAMPLE 1 Evaluate Trigonometric Functions Given a Point

The terminal side of θ in standard position contains the point at $(-3, -4)$. Find the exact values of the six trigonometric functions of θ .

Step 1 Draw the angle, and find the value of r .

$$\begin{aligned} r &= \sqrt{x^2 + y^2} \\ &= \sqrt{(-3)^2 + (-4)^2} \\ &= \sqrt{25} \text{ or } 5 \end{aligned}$$

Step 2 Use $x = -3$, $y = -4$, and $r = 5$ to write the six trigonometric ratios.

$$\begin{aligned} \sin \theta &= \frac{y}{r} = \frac{-4}{5} \text{ or } -\frac{4}{5} & \cos \theta &= \frac{x}{r} = \frac{-3}{5} \text{ or } -\frac{3}{5} & \tan \theta &= \frac{y}{x} = \frac{-4}{-3} \text{ or } \frac{4}{3} \\ \csc \theta &= \frac{r}{y} = \frac{5}{-4} \text{ or } -\frac{5}{4} & \sec \theta &= \frac{r}{x} = \frac{5}{-3} \text{ or } -\frac{5}{3} & \cot \theta &= \frac{x}{y} = \frac{-3}{-4} \text{ or } \frac{3}{4} \end{aligned}$$

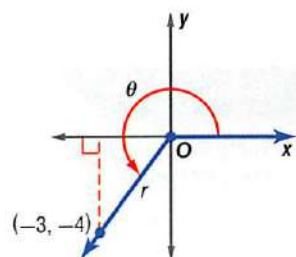

Check Your Progress

- The terminal side of θ in standard position contains the point at $(-6, 2)$. Find the exact values of the six trigonometric functions of θ .

Personal Tutor glencoe.com

If the terminal side of angle θ in standard position lies on the x - or y -axis, the angle is called a **quadrantal angle**.

StudyTip

Quadrantal Angles

The measure of a quadrantal angle is a multiple of 90° or $\frac{\pi}{2}$.

Key Concept

Quadrantal Angles

For Your
FOLDABLE

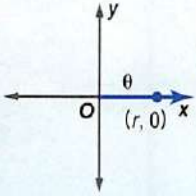
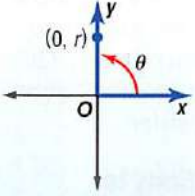
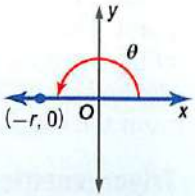
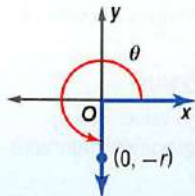
$\theta = 0^\circ$ or 0 radians 	$\theta = 90^\circ$ or $\frac{\pi}{2}$ radians 	$\theta = 180^\circ$ or π radians 	$\theta = 270^\circ$ or $\frac{3\pi}{2}$ radians 
---	--	--	--

EXAMPLE 2 Quadrantal Angles

The terminal side of θ in standard position contains the point at $(0, 6)$. Find the values of the six trigonometric functions of θ .

The point at $(0, 6)$ lies on the positive y -axis, so the quadrantal angle θ is 90° . Use $x = 0$, $y = 6$, and $r = 6$ to write the trigonometric functions.

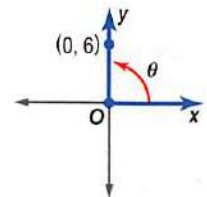

$$\begin{aligned} \sin \theta &= \frac{y}{r} = \frac{6}{6} \text{ or } 1 & \cos \theta &= \frac{x}{r} = \frac{0}{6} \text{ or } 0 & \tan \theta &= \frac{y}{x} = \frac{6}{0} \text{ undefined} \\ \csc \theta &= \frac{r}{y} = \frac{6}{6} \text{ or } 1 & \sec \theta &= \frac{r}{x} = \frac{6}{0} \text{ undefined} & \cot \theta &= \frac{x}{y} = \frac{0}{6} \text{ or } 0 \end{aligned}$$

Check Your Progress

2. The terminal side of θ in standard position contains the point at $(-2, 0)$. Find the values of the six trigonometric functions of θ .

Personal Tutor glencoe.com

Trigonometric Functions with Reference Angles If θ is a nonquadrantal angle in standard position, its **reference angle** θ' is the acute angle formed by the terminal side of θ and the x -axis. The rules for finding the measures of reference angles for $0^\circ < \theta < 360^\circ$ or $0^\circ < \theta < 2\pi$ are shown below.

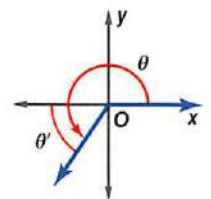

ReadingMath

Theta Prime θ' is read *theta prime*.

Math in Motion,
Animation glencoe.com

Key Concept

Reference Angles

For Your
FOLDABLE

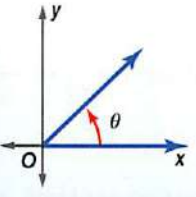
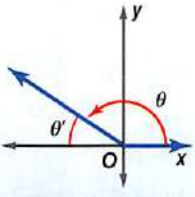
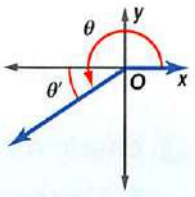
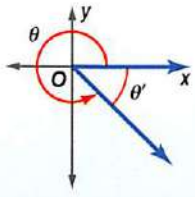
Quadrant I	Quadrant II	Quadrant III	Quadrant IV
			
$\theta' = \theta$	$\theta' = 180^\circ - \theta$ $\theta' = \pi - \theta$	$\theta' = \theta - 180^\circ$ $\theta' = \theta - \pi$	$\theta' = 360^\circ - \theta$ $\theta' = 2\pi - \theta$

If the measure of θ is greater than 360° or less than 0° , then use a coterminal angle with a positive measure between 0° and 360° to find the reference angle.

StudyTip

Graphing Angles

You can refer to the diagram in the Lesson 13-2 Concept Summary to help you sketch angles.

EXAMPLE 3 Find Reference Angles

Sketch each angle. Then find its reference angle.

a. 210°

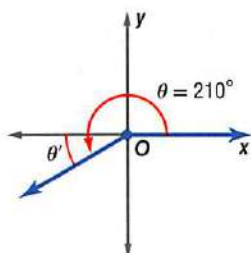

The terminal side of 210° lies in Quadrant III.

$$\begin{aligned}\theta' &= \theta - 180^\circ \\ &= 210^\circ - 180^\circ \text{ or } 30^\circ\end{aligned}$$

b. $-\frac{5\pi}{4}$

coterminal angle: $-\frac{5\pi}{4} + 2\pi = \frac{3\pi}{4}$

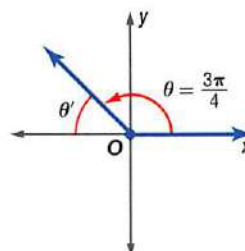

The terminal side of $\frac{3\pi}{4}$ lies in Quadrant II.

$$\begin{aligned}\theta' &= \pi - \theta \\ &= \pi - \frac{3\pi}{4} \text{ or } \frac{\pi}{4}\end{aligned}$$

Check Your Progress

3A. -110°

3B. $\frac{2\pi}{3}$

Personal Tutor glencoe.com

You can use reference angles to evaluate trigonometric functions for any angle θ . The sign of a function is determined by the quadrant in which the terminal side of θ lies. Use these steps to evaluate a trigonometric function for any angle θ .

Key Concept

Evaluate Trigonometric Functions

For Your FOLDABLE

- Step 1** Find the measure of the reference angle θ' .
- Step 2** Evaluate the trigonometric function for θ' .
- Step 3** Determine the sign of the trigonometric function value. Use the quadrant in which the terminal side of θ lies.

Quadrant II	$\sin \theta, \csc \theta: +$	Quadrant I	$\sin \theta, \csc \theta: +$
	$\cos \theta, \sec \theta: -$		$\cos \theta, \sec \theta: +$
	$\tan \theta, \cot \theta: -$		$\tan \theta, \cot \theta: +$
Quadrant III	$\sin \theta, \csc \theta: -$	Quadrant IV	$\sin \theta, \csc \theta: -$
	$\cos \theta, \sec \theta: -$		$\cos \theta, \sec \theta: +$
	$\tan \theta, \cot \theta: +$		$\tan \theta, \cot \theta: -$

You can use the trigonometric values of angles measuring 30° , 45° , and 60° that you learned in Lesson 13-1.

Trigonometric Values for Special Angles

Sine	Cosine	Tangent	Cosecant	Secant	Cotangent
$\sin 30^\circ = \frac{1}{2}$	$\cos 30^\circ = \frac{\sqrt{3}}{2}$	$\tan 30^\circ = \frac{\sqrt{3}}{3}$	$\csc 30^\circ = 2$	$\sec 30^\circ = \frac{2\sqrt{3}}{3}$	$\cot 30^\circ = \sqrt{3}$
$\sin 45^\circ = \frac{\sqrt{2}}{2}$	$\cos 45^\circ = \frac{\sqrt{2}}{2}$	$\tan 45^\circ = 1$	$\csc 45^\circ = \sqrt{2}$	$\sec 45^\circ = \sqrt{2}$	$\cot 45^\circ = 1$
$\sin 60^\circ = \frac{\sqrt{3}}{2}$	$\cos 60^\circ = \frac{1}{2}$	$\tan 60^\circ = \sqrt{3}$	$\csc 60^\circ = \frac{2\sqrt{3}}{3}$	$\sec 60^\circ = 2$	$\cot 60^\circ = \frac{\sqrt{3}}{3}$

EXAMPLE 4 Use a Reference Angle to Find a Trigonometric Value

Find the exact value of each trigonometric function.

a. $\cos 240^\circ$

The terminal side of 240° lies in Quadrant III.

$$\theta' = \theta - 180^\circ$$

Find the measure of the reference angle.

$$= 240^\circ - 180^\circ \text{ or } 60^\circ \quad \theta = 240^\circ$$

$$\cos 240^\circ = -\cos 60^\circ \text{ or } -\frac{1}{2} \quad \text{The cosine function is negative in Quadrant III.}$$

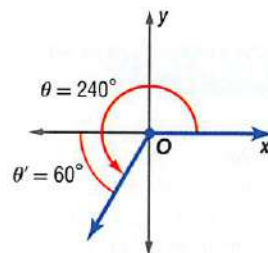

b. $\csc \frac{5\pi}{6}$

The terminal side of $\frac{5\pi}{6}$ lies in Quadrant II.

$$\theta' = \pi - \theta$$

Find the measure of the reference angle.

$$= \pi - \frac{5\pi}{6} \text{ or } \frac{\pi}{6} \quad \theta = \frac{5\pi}{6}$$

$$\csc \frac{5\pi}{6} = \csc \frac{\pi}{6} \quad \text{The cosecant function is positive in Quadrant II.}$$

$$= \csc 30^\circ \quad \frac{\pi}{6} \text{ radians} = 30^\circ$$

$$= 2 \quad \csc 30^\circ = \frac{1}{\sin 30}$$

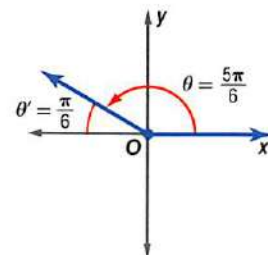

Check Your Progress

4A. $\cos 135^\circ$

4B. $\tan \frac{5\pi}{6}$

Personal Tutor glencoe.com

Real-World EXAMPLE 5 Use Trigonometric Functions

RIDES The swing arms of the ride at the right are 84 feet long and the height of the axis from which the arms swing is 97 feet. What is the total height of the ride at the peak of the arc?

$$\text{coterminal angle: } -200^\circ + 360^\circ = 160^\circ$$

$$\text{reference angle: } 180^\circ - 160^\circ = 20^\circ$$

$$\sin \theta = \frac{y}{r} \quad \text{Sine function}$$

$$\sin 20^\circ = \frac{y}{84} \quad \theta = 20^\circ \text{ and } r = 84$$

$$84 \sin 20^\circ = y \quad \text{Multiply each side by 84.}$$

$$28.7 \approx y \quad \text{Use a calculator to solve for } y.$$

Since y is approximately 28.7 feet, the total height of the ride at its peak is $28.7 + 97$ or about 125.7 feet.

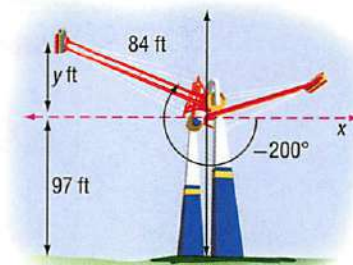

Real-World Link

On a swing ride, riders experience weightlessness just like the drop side of a roller coaster. The ride lasts one minute and reaches speeds of 60 miles per hour in both directions.

Source: Cedar Point

Check Your Progress

5. **RIDES** A similar ride that is smaller has swing arms that are 72 feet long. The height of the axis from which the arms swing is 88 feet, and the angle of rotation from the standard position is -195° . What is the total height of the ride at the peak of the arc?

Personal Tutor glencoe.com

Check Your Understanding

Examples 1 and 2
pp. 825–826

The terminal side of θ in standard position contains each point. Find the exact values of the six trigonometric functions of θ .

1. (1, 2) 2. $(-8, -15)$ 3. $(0, -4)$

Example 3
p. 827

Sketch each angle. Then find its reference angle.

4. 300° 5. 115° 6. $-\frac{3\pi}{4}$

Example 4
p. 828

Find the exact value of each trigonometric function.

7. $\sin \frac{3\pi}{4}$ 8. $\tan \frac{5\pi}{3}$ 9. $\sec 120^\circ$ 10. $\sin 300^\circ$

Example 5
p. 828

11. **ENTERTAINMENT** Alejandra opens her portable DVD player so that it forms a 125° angle. The screen is $5\frac{1}{2}$ inches long.

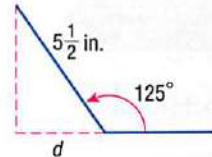

- Redraw the diagram so that the angle is in standard position on the coordinate plane.
- Find the reference angle. Then write a trigonometric function that can be used to find the distance to the wall d that she can place the DVD player.
- Use the function to find the distance. Round to the nearest tenth.

Practice and Problem Solving

= **Step-by-Step Solutions** begin on page R20.
Extra Practice begins on page 947.

Examples 1 and 2
pp. 825–826

The terminal side of θ in standard position contains each point. Find the exact values of the six trigonometric functions of θ .

12. (5, 12) 13. $(-6, 8)$ 14. (3, 0)
15. $(0, -7)$ 16. $(4, -2)$ 17. $(-9, -3)$

Example 3
p. 827

Sketch each angle. Then find its reference angle.

18. 195° 19. 285° 20. -250°
21. $\frac{7\pi}{4}$ 22. $-\frac{\pi}{4}$ 23. 400°

Example 4
p. 828

Find the exact value of each trigonometric function.

24. $\sin 210^\circ$ 25. $\tan 315^\circ$ 26. $\cos 150^\circ$ 27. $\csc 225^\circ$
28. $\sin \frac{4\pi}{3}$ 29. $\cos \frac{5\pi}{3}$ 30. $\cot \frac{5\pi}{4}$ 31. $\sec \frac{11\pi}{6}$

Example 5
p. 828

32. **SOCCER** A soccer player x feet from the goalie kicks the ball toward the goal, as shown in the figure. The goalie jumps up and catches the ball 7 feet in the air.

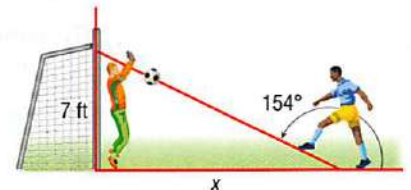

- Find the reference angle. Then write a trigonometric function that can be used to find how far from the goalie the soccer player was when he kicked the ball.
- About how far away from the goalie was the soccer player?

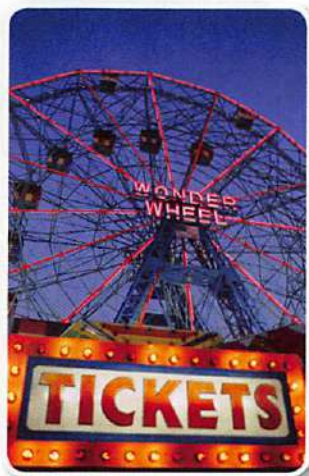

Real-World Link

The Wonder Wheel, which holds 144 people, is different from most Ferris wheels. It has eight stationary cars and sixteen cars that roll along tracks within the wheel's structure.

Source: Amusement Park History

- 33. SPRINKLER** A sprinkler rotating back and forth shoots water out a distance of 10 feet. From the horizontal position, it rotates 145° before reversing its direction. At a 145° angle, about how far from the sprinkler does the water reach?

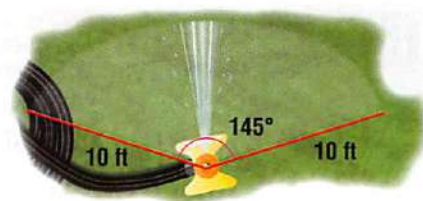

- 34. BASKETBALL** The formula $R = \frac{V_0^2 \sin 2\theta}{32}$ gives the distance of a basketball shot with an initial velocity of V_0 feet per second at an angle θ with the ground.
- If the basketball was shot with an initial velocity of 24 feet per second at an angle of 75° , how far will the basketball travel?
 - If the basketball was shot at an angle of 65° and traveled 10 feet, what was its initial velocity?
 - If the basketball was shot with an initial velocity of 30 feet per second and traveled 12 feet, at what angle was it shot?
- 35. PHYSICS** A rock is shot off the edge of a ravine with a slingshot at an angle of 65° and with an initial velocity of 6 meters per second. The equation that represents the horizontal distance of the rock x is $x = v_0 (\cos \theta)t$, where v_0 is the initial velocity, θ is the angle at which it is shot, and t is the time in seconds. About how far does the rock travel after 4 seconds?
- 36. FERRIS WHEELS** The Wonder Wheel Ferris wheel at Coney Island has a radius of about 68 feet and is 15 feet off the ground. After a person gets on the bottom car, the Ferris wheel rotates 202.5° counterclockwise before stopping. How high above the ground is this car when it has stopped?

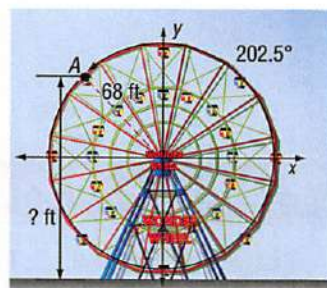

Suppose θ is an angle in standard position whose terminal side is in the given quadrant. For each function, find the exact values of the remaining five trigonometric functions of θ .

37. $\sin \theta = \frac{4}{5}$, Quadrant II
38. $\tan \theta = -\frac{2}{3}$, Quadrant IV
39. $\cos \theta = -\frac{8}{17}$, Quadrant III
40. $\cot \theta = -\frac{12}{5}$, Quadrant IV

Find the exact value of each trigonometric function.

41. $\cot 270^\circ$
42. $\csc 180^\circ$
43. $\sin 570^\circ$
44. $\tan\left(-\frac{7\pi}{6}\right)$
45. $\cos\left(-\frac{11\pi}{6}\right)$
46. $\cot \frac{9\pi}{4}$

H.O.T. Problems

Use Higher-Order Thinking Skills

- 47. CHALLENGE** For an angle θ in standard position, $\sin \theta = \frac{\sqrt{2}}{2}$ and $\tan \theta = -1$. Can the value of θ be 225° ? Justify your reasoning.
- 48. REASONING** Determine whether $3 \sin 60^\circ = \sin 180^\circ$ is true or false. Explain your reasoning.
- 49. REASONING** Use the sine and cosine functions to explain why $\cot 180^\circ$ is undefined.
- 50. OPEN ENDED** Give an example of a negative angle θ for which $\sin \theta > 0$ and $\cos \theta < 0$.
- 51. WRITING IN MATH** Describe the steps for evaluating a trigonometric function for an angle θ that is greater than 90° . Include a description of a reference angle.

Standardized Test Practice

52. **SHORT RESPONSE** If the sum of two numbers is 21 and their difference is 3, what is their product?
53. **GEOMETRY** D is the midpoint of \overline{BC} , and A and E are the midpoints of \overline{BD} and \overline{DC} , respectively. If the length of \overline{AE} is 12, what is the length of \overline{BC} ?
- A 6 C 24
B 12 D 48
54. The expression $(-6 + i)^2$ is equivalent to which of the following expressions?
- F $-12i$ H $36 - 12i$
G $36 - i$ J $35 - 12i$
55. **SAT/ACT** Of the following, which is least?
- A $1 + \frac{1}{4}$ C $\frac{1}{4} - 1$
B $1 - \frac{1}{4}$ D $1 \times \frac{1}{4}$

Spiral Review

Rewrite each radian measure in degrees. (Lesson 13-2)

56. $\frac{4}{3}\pi$

57. $\frac{11}{6}\pi$

58. $-\frac{17}{4}\pi$

Solve each equation. (Lesson 13-1)

59. $\cos a = \frac{13}{17}$

60. $\sin 30 = \frac{b}{6}$

61. $\tan c = \frac{9}{4}$

62. **ARCHITECTURE** A memorial being constructed in a city park will be a brick wall, with a top row of six gold-plated bricks engraved with the names of six local war veterans. Each row has two more bricks than the row above it. Prove that the number of bricks in the top n rows is $n^2 + 5n$. (Lesson 11-7)

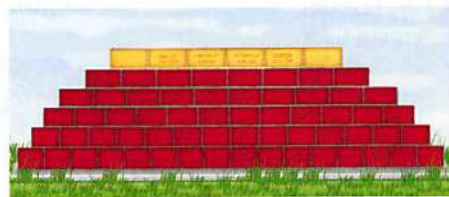

63. **LEGENDS** There is a legend of a king who wanted to reward a boy for a good deed. The king gave the boy a choice. He could have \$1,000,000 at once, or he could be rewarded daily for a 30-day month, with one penny on the first day, two pennies on the second day, and so on, receiving twice as many pennies each day as the previous day. How much would the second option be worth? (Lesson 11-3)

Write an equation for each circle given the endpoints of a diameter. (Lesson 10-3)

64. $(2, -4), (10, 2)$

65. $(-1, -10), (-7, 6)$

66. $(9, 0), (4, -7)$

Simplify each expression. (Lesson 9-2)

67. $\frac{5}{x^2 + 6x + 8} + \frac{x}{x^2 - 3x - 28}$

68. $\frac{3x}{x^2 + 8x - 20} - \frac{6}{x^2 + 7x - 18}$

69. $\frac{4}{3x^2 + 12x} + \frac{2x}{x^2 - 2x - 24}$

Solve each equation or inequality. Round to the nearest ten-thousandth. (Lesson 8-6)

70. $8^x = 30$

71. $5^x = 64$

72. $3^{x+2} = 41$

Evaluate each expression. (Lesson 7-6)

73. $16^{-\frac{1}{4}}$

74. $27^{\frac{4}{3}}$

75. $25^{-\frac{5}{2}}$

Skills Review

Solve for x . (Concepts and Skills Bank 1)

76. $\frac{x+2}{18} = \frac{x-2}{9}$

77. $\frac{x+5}{x-1} = \frac{7}{4}$

78. $\frac{5}{x+8} = \frac{15}{2x+20}$

Law of Sines

Then

You found side lengths and angle measures of right triangles. (Lesson 13-1)

Now

- Find the area of a triangle using two sides and an included angle.
- Use the Law of Sines to solve triangles.

New Vocabulary

Law of Sines
solving a triangle

Math Online

glencoe.com

- Extra Examples
- Personal Tutor
- Self-Check Quiz
- Homework Help

Why?

Mars has hundreds of thousands of craters. These craters are named after famous scientists, science fiction authors, and towns on Earth. The craters named Wahoo, Wabash, and Naukan are shown in the figure. You can use trigonometry to find the distance between Wahoo and Naukan.

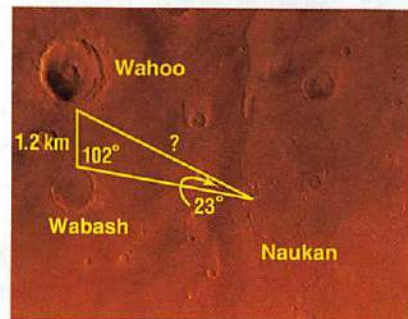

Find the Area of a Triangle In the triangle at the right, $\sin A = \frac{h}{c}$, or $h = c \sin A$.

$$\text{Area} = \frac{1}{2}bh \quad \text{Formula for area of a triangle}$$

$$\text{Area} = \frac{1}{2}b(c \sin A) \quad \text{Replace } h \text{ with } c \sin A.$$

$$\text{Area} = \frac{1}{2}bc \sin A \quad \text{Simplify.}$$

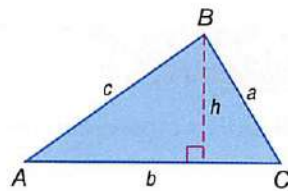

You can use this formula or two other formulas to find the area of a triangle if you know the lengths of two sides and the measure of the included angle.



Key Concept

Area of a Triangle

For Your
FOLDABLE

Words The area of a triangle is one half the product of the lengths of two sides and the sine of their included angle.

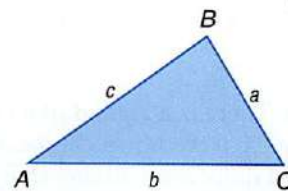

Symbols $\text{Area} = \frac{1}{2}bc \sin A$ $\text{Area} = \frac{1}{2}ac \sin B$ $\text{Area} = \frac{1}{2}ab \sin C$

EXAMPLE 1 Find the Area of a Triangle

Find the area of $\triangle ABC$ to the nearest tenth.

In $\triangle ABC$, $a = 8$, $b = 9$, and $C = 104^\circ$.

$$\text{Area} = \frac{1}{2}ab \sin C$$

$$= \frac{1}{2}(8)(9) \sin 104^\circ$$

$$\approx 34.9$$

Based on the known measures, use the third area formula.

Substitution

Simplify.

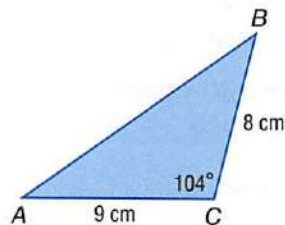

So, the area is about 34.9 square centimeters.



Check Your Progress

- Find the area of $\triangle ABC$ to the nearest tenth if $A = 31^\circ$, $b = 18$ meters, and $c = 22$ meters.



Personal Tutor glencoe.com

Use the Law of Sines to Solve Triangles You can use the area formulas to derive the **Law of Sines**, which shows the relationships between side lengths of a triangle and the sines of the angles opposite them.

$$\frac{1}{2}bc \sin A = \frac{1}{2}ac \sin B = \frac{1}{2}ab \sin C$$

Set the area formulas equal to each other.

$$bc \sin A = ac \sin B = ab \sin C$$

Multiply each expression by 2.

$$\frac{bc \sin A}{abc} = \frac{ac \sin B}{abc} = \frac{ab \sin C}{abc}$$

Divide each expression by abc .

$$\frac{\sin A}{a} = \frac{\sin B}{b} = \frac{\sin C}{c}$$

Simplify.

Key Concept

Law of Sines

For Your
FOLDABLE

In $\triangle ABC$, if sides with lengths a , b , and c are opposite angles with measures A , B , and C , respectively, then the following is true.

$$\frac{\sin A}{a} = \frac{\sin B}{b} = \frac{\sin C}{c}$$

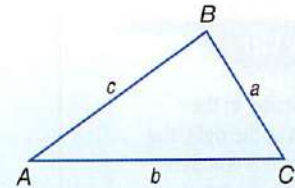

You can use the Law of Sines to solve a triangle if you know either one of the following.

- the measures of two angles and any side (angle-angle-side AAS or angle-side-angle ASA cases)
- the measures of two sides and the angle opposite one of the sides (side-side-angle SSA case)

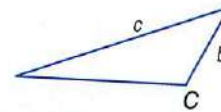
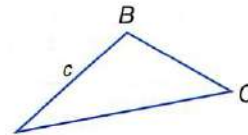

Using given measures to find all unknown side lengths and angle measures of a triangle is called **solving a triangle**.

StudyTip

Alternative Representations

The Law of Sines may also be written as

$$\frac{a}{\sin A} = \frac{b}{\sin B} = \frac{c}{\sin C}$$

So, the expressions below could also be used to solve the triangle in Example 2.

$$\begin{aligned} \bullet \frac{a}{\sin 55^\circ} &= \frac{3}{\sin 80^\circ} \\ \bullet \frac{b}{\sin 45^\circ} &= \frac{3}{\sin 80^\circ} \end{aligned}$$

EXAMPLE 2 Solve a Triangle Given Two Angles and a Side

Solve $\triangle ABC$. Round to the nearest tenth if necessary.

Step 1 Find the measure of the third angle.

$$m\angle A = 180 - (80 + 45) \text{ or } 55^\circ$$

Step 2 Use the Law of Sines to find side lengths a and b . Write an equation to find each variable.

$$\frac{\sin A}{a} = \frac{\sin C}{c}$$

Law of Sines

$$\frac{\sin 55^\circ}{a} = \frac{\sin 80^\circ}{3}$$

Substitution

$$a = \frac{3 \sin 55^\circ}{\sin 80^\circ}$$

Solve for each variable.

$$a \approx 2.5$$

Use a calculator.

$$\frac{\sin B}{b} = \frac{\sin C}{c}$$

$$\frac{\sin 45^\circ}{b} = \frac{\sin 80^\circ}{3}$$

$$b = \frac{3 \sin 45^\circ}{\sin 80^\circ}$$

$$b \approx 2.2$$

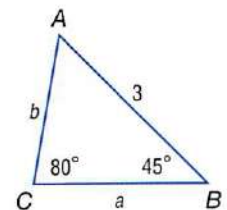

So, $A = 55^\circ$, $a \approx 2.5$, and $b \approx 2.2$.

Check Your Progress

2. Solve $\triangle NPQ$ if $P = 42^\circ$, $Q = 65^\circ$, and $n = 5$.

StudyTip

Two Solutions

A situation in which two solutions for a triangle exist is called the *ambiguous case*.

If you are given the measures of two angles and a side, exactly one triangle is possible. However, if you are given the measures of two sides and the angle opposite one of them, zero, one, or two triangles may be possible. So, when solving a triangle using the SSA case, zero, one, or two solutions are possible.

StudyTip

A is Acute In the figures at the right, the altitude h is compared to a because h is the minimum distance from C to \overline{AB} when A is acute.

$$\sin A = \frac{\text{opp}}{\text{hyp}}$$

$$\sin A = \frac{h}{b}$$

Key Concept

Possible Triangles in SSA Case

For Your
FOLDABLE

Consider a triangle in which a , b , and $m\angle A$ are given.

$\angle A$ is Acute.

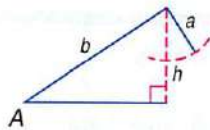

$a < h$
no solution

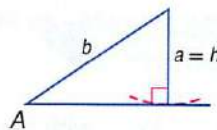

$a = h$
one solution

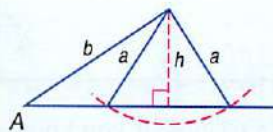

$h < a < b$
two solutions

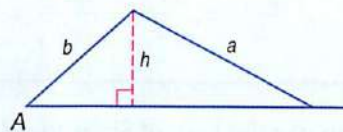

$a \geq b$
one solution

$\angle A$ is Right or Obtuse.

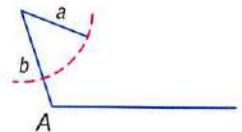

$a \leq b$
no solution

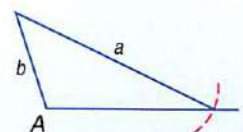

$a > b$
one solution

Since $\sin A = \frac{h}{b}$, you can use $h = b \sin A$ to find h in the acute triangles.

EXAMPLE 3 Solve a Triangle Given Two Sides and an Angle

Determine whether each triangle has *no solution*, *one solution*, or *two solutions*. Then solve the triangle. Round side lengths to the nearest tenth and angle measures to the nearest degree.

- a. In $\triangle RST$, $R = 105^\circ$, $r = 9$, and $s = 6$.

Because $\angle R$ is obtuse and $9 > 6$, you know that one solution exists.

- Step 1** Use the Law of Sines to find $m\angle S$.

$$\frac{\sin S}{6} = \frac{\sin 105^\circ}{9} \quad \text{Law of Sines}$$

$$\sin S = \frac{6 \sin 105^\circ}{9} \quad \text{Multiply each side by 6.}$$

$$\begin{aligned} \sin S &\approx 0.6440 && \text{Use a calculator.} \\ S &\approx 40^\circ && \text{Use the } \sin^{-1} \text{ function.} \end{aligned}$$

- Step 2** Find $m\angle T$.
 $m\angle T \approx 180 - (105 + 40)$ or 35°

- Step 3** Use the Law of Sines to find t .

$$\frac{\sin 35^\circ}{t} \approx \frac{\sin 105^\circ}{9} \quad \text{Law of Sines}$$

$$t \approx \frac{9 \sin 35^\circ}{\sin 105^\circ} \quad \text{Solve for } t.$$

$$t \approx 5.3 \quad \text{Use a calculator.}$$

So, $S \approx 40^\circ$, $T \approx 35^\circ$, and $t \approx 5.3$.

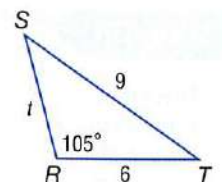

- b. In $\triangle ABC$, $A = 54^\circ$, $a = 6$, and $b = 8$.

Since $\angle A$ is acute and $6 < 8$, find h and compare it to a .

$$b \sin A = 8 \sin 54^\circ \approx 6.5 \quad b = 8 \text{ and } A = 54^\circ$$

Use a calculator.

Since $6 \leq 6.5$ or $a \leq h$, there is no solution.

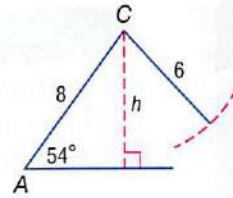

- c. In $\triangle ABC$, $A = 35^\circ$, $a = 17$, and $b = 20$.

Since $\angle A$ is acute and $17 < 20$, find h and compare it to a .

$$b \sin A = 20 \sin 35^\circ \approx 11.5 \quad b = 20 \text{ and } A = 35^\circ$$

Use a calculator.

Since $11.5 < 17 < 20$ or $h < a < b$, there are two solutions. So, there are two triangles to be solved.

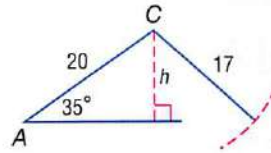

Case 1 $\angle B$ is acute.

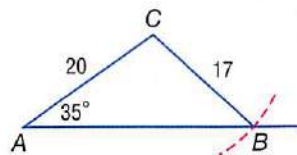

Step 1 Find $m\angle B$.

$$\frac{\sin B}{20} = \frac{\sin 35^\circ}{17} \quad \text{Law of Sines}$$

$$\sin B = \frac{20 \sin 35^\circ}{17} \quad \text{Solve for } \sin B.$$

$$\sin B \approx 0.6748 \quad \text{Use a calculator.}$$

$$B \approx 42^\circ \quad \text{Find } \sin^{-1} 0.6748.$$

Step 2 Find $m\angle C$.

$$m\angle C \approx 180 - (35 + 42) \text{ or } 103^\circ$$

Step 3 Find c .

$$\frac{\sin 103^\circ}{c} = \frac{\sin 35^\circ}{17} \quad \text{Law of Sines}$$

$$c = \frac{17 \sin 103^\circ}{\sin 35^\circ} \quad \text{Solve for } c.$$

$$c \approx 28.9 \quad \text{Simplify.}$$

Case 2 $\angle B$ is obtuse.

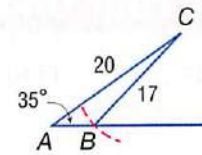

Step 1 Find $m\angle B$.

The sine function also has a positive value in Quadrant II. So, find an obtuse angle B for which $\sin B \approx 0.6748$.

$$m\angle B \approx 180^\circ - 42^\circ \text{ or } 138^\circ$$

Step 2 Find $m\angle C$.

$$m\angle C \approx 180 - (35 + 138) \text{ or } 7^\circ$$

Step 3 Find c .

$$\frac{\sin 7^\circ}{c} \approx \frac{\sin 35^\circ}{17} \quad \text{Law of Sines}$$

$$c \approx \frac{17 \sin 7^\circ}{\sin 35^\circ} \quad \text{Solve for } c.$$

$$c \approx 3.6 \quad \text{Simplify.}$$

So, one solution is $B \approx 42^\circ$, $C \approx 103^\circ$, and $c \approx 28.9$, and another solution is $B \approx 138^\circ$, $C \approx 7^\circ$, and $c \approx 3.6$.

StudyTip

Reference Angle In the triangle in Case 2, you are using the reference angle 42° to find the other value of B .

Check Your Progress

Determine whether each triangle has *no* solution, *one* solution, or *two* solutions. Then solve the triangle. Round side lengths to the nearest tenth and angle measures to the nearest degree.

3A. In $\triangle RST$, $R = 95^\circ$, $r = 10$, and $s = 12$.

3B. In $\triangle MNP$, $N = 32^\circ$, $n = 7$, and $p = 4$.

3C. In $\triangle ABC$, $A = 47^\circ$, $a = 15$, and $b = 18$.

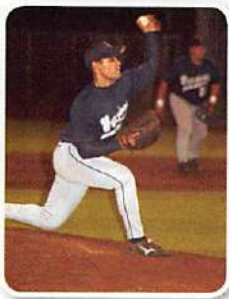

Real-World EXAMPLE 4 Use the Law of Sines to Solve a Problem

BASEBALL A baseball is hit between second and third bases and is caught at point B , as shown in the figure. How far away from second base was the ball caught?

$$\frac{\sin 72^\circ}{90} = \frac{\sin 43^\circ}{x} \quad \text{Law of Sines}$$

$$x \sin 72^\circ = 90 \sin 43^\circ \quad \text{Cross products}$$

$$x = \frac{90 \sin 43^\circ}{\sin 72^\circ} \quad \text{Solve for } x.$$

$$x \approx 64.5 \quad \text{Use a calculator.}$$

So, the distance is about 64.5 feet.

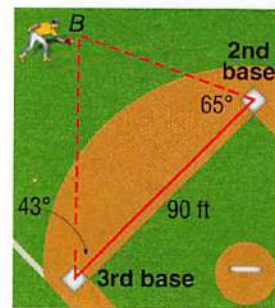

Real-World Link

High school and college baseball fields share the same infield dimensions as professional baseball fields. The outfield dimensions vary greatly.

Source: *Baseball Digest Magazine*

Check Your Progress

4. How far away from third base was the ball caught?

Personal Tutor glencoe.com

Check Your Understanding

Example 1 p. 832

Find the area of $\triangle ABC$ to the nearest tenth, if necessary.

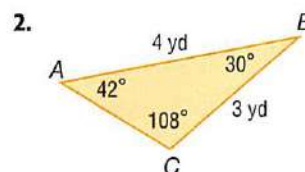
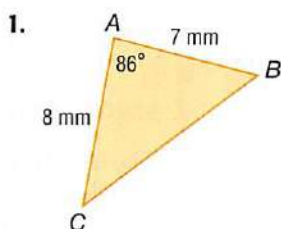

3. $A = 40^\circ, b = 11 \text{ cm}, c = 6 \text{ cm}$

4. $B = 103^\circ, a = 20 \text{ in.}, c = 18 \text{ in.}$

Example 2 p. 833

Solve each triangle. Round side lengths to the nearest tenth and angle measures to the nearest degree.

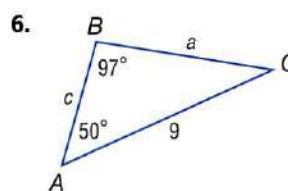
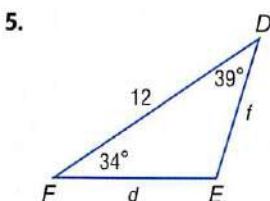

7. Solve $\triangle FGH$ if $G = 80^\circ, H = 40^\circ$, and $g = 14$.

Example 3 pp. 834–835

Determine whether each triangle has *no* solution, *one* solution, or *two* solutions. Then solve the triangle. Round side lengths to the nearest tenth and angle measures to the nearest degree.

8. $A = 95^\circ, a = 19, b = 12$

9. $A = 60^\circ, a = 15, b = 24$

10. $A = 34^\circ, a = 8, b = 13$

11. $A = 30^\circ, a = 3, b = 6$

Example 4 p. 836

12. **SPACE** Refer to the beginning of the lesson. Find the distance between the Wahoo Crater and the Naukan Crater on Mars.

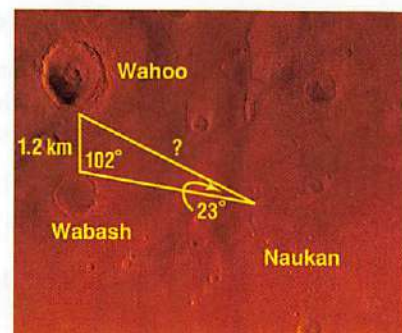

Practice and Problem Solving

Step-by-Step Solutions begin on page R20.
Extra Practice begins on page 947.

Example 1
 p. 832

Find the area of $\triangle ABC$ to the nearest tenth.

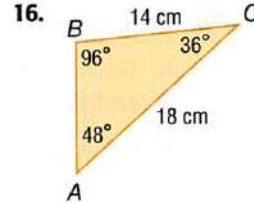
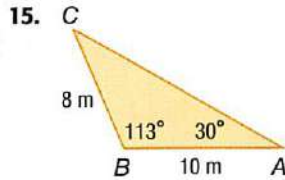
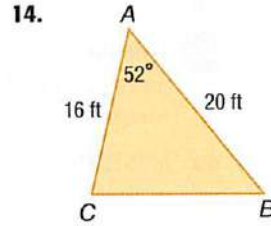
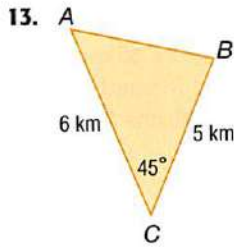

17. $C = 25^\circ, a = 4 \text{ ft}, b = 7 \text{ ft}$

18. $A = 138^\circ, b = 10 \text{ in.}, c = 20 \text{ in.}$

19. $B = 92^\circ, a = 14.5 \text{ m}, c = 9 \text{ m}$

20. $C = 116^\circ, a = 2.7 \text{ cm}, b = 4.6 \text{ cm}$

Example 2
 p. 833

Solve each triangle. Round side lengths to the nearest tenth and angle measures to the nearest degree.

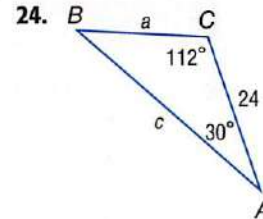
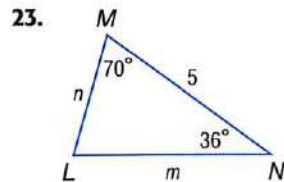
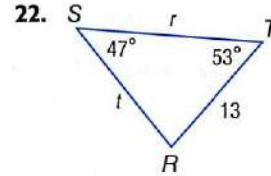
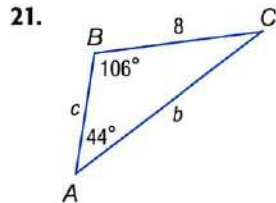

25. Solve $\triangle HJK$ if $H = 53^\circ, J = 20^\circ$, and $h = 31$.

26. Solve $\triangle NPQ$ if $P = 109^\circ, Q = 57^\circ$, and $n = 22$.

27. Solve $\triangle ABC$ if $A = 50^\circ, a = 2.5$, and $C = 67^\circ$.

28. Solve $\triangle ABC$ if $B = 18^\circ, C = 142^\circ$, and $b = 20$.

Example 3
 pp. 834–835

Determine whether each triangle has *no solution*, *one solution*, or *two solutions*. Then solve the triangle. Round side lengths to the nearest tenth and angle measures to the nearest degree.

29. $A = 100^\circ, a = 7, b = 3$

30. $A = 75^\circ, a = 14, b = 11$

31. $A = 38^\circ, a = 21, b = 18$

32. $A = 52^\circ, a = 9, b = 20$

33. $A = 42^\circ, a = 5, b = 6$

34. $A = 44^\circ, a = 14, b = 19$

35. $A = 131^\circ, a = 15, b = 32$

36. $A = 30^\circ, a = 17, b = 34$

Example 4
p. 836

GEOGRAPHY In Hawaii, the distance from Hilo to Kailua is 57 miles, and the distance from Hilo to Captain Cook is 55 miles.

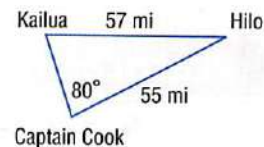

37. What is the measure of the angle formed at Hilo?
38. What is the distance between Kailua and Captain Cook?

39. TORNADOES Tornado sirens A , B , and C form a triangular region in one area of a city. Sirens A and B are 8 miles apart. The angle formed at siren A is 112° , and the angle formed at siren B is 40° . How far apart are sirens B and C ?

40. MYSTERIES The Bermuda Triangle is a region of the Atlantic Ocean between Bermuda, Miami, Florida, and San Juan, Puerto Rico. It is an area where ships and airplanes have been rumored to mysteriously disappear.



- a. What is the distance between Miami and Bermuda?
b. What is the approximate area of the Bermuda Triangle?

41. BICYCLING One side of a triangular cycling path is 4 miles long. The angle opposite this side is 64° . Another angle formed by the triangular path measures 66° .

- a. Sketch a drawing of the situation. Label the missing sides a and b .
b. Write equations that could be used to find the lengths of the missing sides.
c. What is the perimeter of the path?

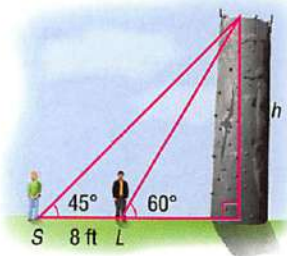

42. ROCK CLIMBING Savannah S and Leon L are standing 8 feet apart in front of a rock climbing wall, as shown at the right. What is the height of the wall? Round to the nearest tenth.



Real-World Link

At 65 feet high, one of the tallest indoor rock climbing walls in the world is located in Bloomington, Illinois.

Source: HighBeam Research, Inc.

H.O.T. Problems

Use **Higher-Order Thinking Skills**

43. FIND THE ERROR In $\triangle RST$, $R = 56^\circ$, $r = 24$, and $t = 12$. Cameron and Gabriela are using the Law of Sines to find T . Is either of them correct? Explain your reasoning.

Cameron
$$\frac{\sin T}{12} = \frac{\sin 56^\circ}{24}$$
$$\sin T \approx 0.4145$$
$$T \approx 24.5^\circ$$

Gabriela
Since $r > t$, there is no solution.

44. CHALLENGE In $\triangle ABC$, $B = 30^\circ$, and $a = 6$. How many triangles can be formed if $b = 5$? Explain your reasoning.

45. CHALLENGE Using the figure at the right, derive the formula $\text{Area} = \frac{1}{2}bc \sin A$.

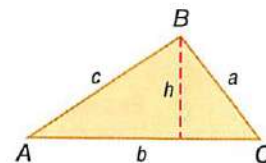

46. REASONING Find the side lengths of two different triangles ABC that can be formed if $A = 55^\circ$ and $C = 20^\circ$.

47. WRITING IN MATH Use the Law of Sines to explain why a and b do not have unique values in the figure shown.

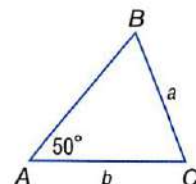

48. OPEN ENDED Given that $E = 62^\circ$ and $d = 38$, find a value for e such that no triangle DEF can exist. Explain your reasoning.

Standardized Test Practice

49. **SHORT RESPONSE** Given the graphs of $f(x)$ and $g(x)$, what is the value of $f(g(4))$?

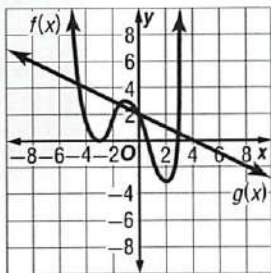

50. **STATISTICS** If the average of seven consecutive odd integers is n , what is the median of these seven integers?
- A 0 C n
 B 7 D $n - 2$

51. One zero of $f(x) = x^3 - 7x^2 - 6x + 72$ is 4. What is the factored form of the expression $x^3 - 7x^2 - 6x + 72$?

- F $(x - 6)(x + 3)(x + 4)$
 G $(x - 6)(x + 3)(x - 4)$
 H $(x + 6)(x + 3)(x - 4)$
 J $(x + 12)(x - 1)(x - 4)$

52. **SAT/ACT** Three people are splitting \$48,000 using the ratio 5 : 4 : 3. What is the amount of the greatest share?

- A \$12,000
 B \$16,000
 C \$20,000
 D \$24,000

Spiral Review

Find the exact value of each trigonometric function. (Lesson 13-3)

53. $\sin 210^\circ$ 54. $\cos \frac{3}{4}\pi$ 55. $\cot 60^\circ$

Find an angle with a positive measure and an angle with a negative measure that are coterminal with each angle. (Lesson 13-2)

56. 125° 57. -32° 58. $\frac{2}{3}\pi$

59. **CLOCKS** Jun's grandfather clock is broken. When she sets the pendulum in motion by holding it against the side of the clock and letting it go, it swings 24 centimeters to the other side, then 18 centimeters back, then 13.5 centimeters, and so on. What is the total distance that the pendulum swings before it stops? (Lesson 11-5)

Find the sum of each infinite series, if it exists. (Lesson 11-4)

60. $64 + 48 + 36 + \dots$ 61. $27 + 36 + 48 + \dots$ 62. $\sum_{n=1}^{\infty} 0.5(1.1)^n$

63. **ASTRONOMY** At its closest point, Earth is 91.8 million miles from the center of the Sun. At its farthest point, Earth is 94.9 million miles from the center of the Sun. Write an equation for the orbit of Earth, assuming that the center of the orbit is the origin and the Sun lies on the x -axis. (Lesson 10-4)

Simplify. (Lesson 7-4)

64. $\sqrt{(x - 4)^2}$ 65. $\sqrt{(y + 2)^4}$ 66. $\sqrt[3]{(a - b)^6}$

Skills Review

Evaluate each expression if $w = 6$, $x = -4$, $y = 1.5$, and $z = \frac{3}{4}$. (Lesson 1-1)

67. $w^2 + y^2 - 6xz$ 68. $x^2 + z^2 + 5wy$ 69. $wy + xz + w^2 - x^2$

Geometry Lab

Regular Polygons

You can use central angles of circles to investigate characteristics of regular polygons inscribed in a circle. Recall that a regular polygon is inscribed in a circle if each of its vertices lies on the circle.

ACTIVITY Collect the Data

- Step 1** Use a compass to draw a circle with a radius of one inch.
- Step 2** Inscribe an equilateral triangle inside the circle. To do this, use a protractor to measure three angles of 120° at the center of the circle, since $\frac{360^\circ}{3} = 120^\circ$. Then connect the points where the sides of the angles intersect the circle using a straightedge.
- Step 3** The **apothem** of a regular polygon is a segment that is drawn from the center of the polygon perpendicular to a side of the polygon. Use the cosine of angle θ to find the length of an apothem, labeled a in the diagram.



Model and Analyze

- Make a table like the one shown below and record the length of the apothem of the equilateral triangle. Inscribe each regular polygon named in the table in a circle with radius one inch. Copy and complete the table.

Number of Sides, n	θ	a	Number of Sides, n	θ	a
3	60		7		
4	45		8		
5			9		
6			10		

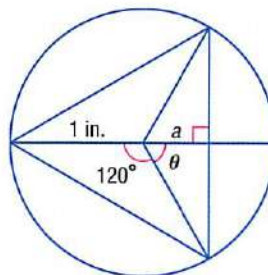

- What do you notice about the measure of θ as the number of sides of the inscribed polygon increases?
- What do you notice about the value of a ?
- MAKE A CONJECTURE** Suppose you inscribe a 30-sided regular polygon inside a circle. Find the measure of angle θ .
- Write a formula that gives the measure of angle θ for a polygon with n sides.
- Write a formula that gives the length of the apothem of a regular polygon inscribed in a circle with radius one inch.
- How would the formula you wrote in Exercise 5 change if the apothem of the circle was not one inch?

Extending the Investigation

Use the table to write each set of ordered pairs. Then use a graphing calculator to find a regression equation for the set of data.

8. (n, θ)

9. (θ, a)

Law of Cosines

Then

You solved triangles by using the Law of Sines. (Lesson 13-4)

Now

- Use the Law of Cosines to solve triangles.
- Choose methods to solve triangles.

New Vocabulary

Law of Cosines

Math Online

glencoe.com

- Extra Examples
- Personal Tutor
- Self-Check Quiz
- Homework Help

Why?

Submersibles, which are lowered into the ocean from ships, are used to take humans to depths they cannot reach by any other means. A submersible 520 meters from its ship shines a light on a shipwreck 338 meters away, as shown in the diagram. You can use trigonometry to find the distance from the ship to the shipwreck.

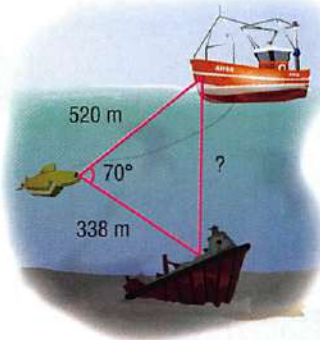

Use Law of Cosines to Solve Triangles You cannot use the Law of Sines to solve a triangle like the one shown above. You can use the **Law of Cosines** to solve a triangle if you know either one of the following.

- the measures of two sides and the included angle (side-angle-side SAS case)
- the measures of three sides (side-side-side SSS case)

Key Concept

Law of Cosines

For Your

FOLDABLE

In $\triangle ABC$, if sides with lengths a , b , and c are opposite angles with measures A , B , and C , respectively, then the following are true.

$$a^2 = b^2 + c^2 - 2bc \cos A$$

$$b^2 = a^2 + c^2 - 2ac \cos B$$

$$c^2 = a^2 + b^2 - 2ab \cos C$$

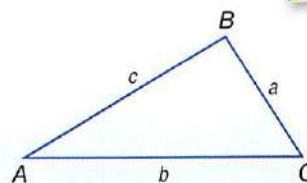

EXAMPLE 1

Solve a Triangle Given Two Sides and the Included Angle

Solve $\triangle ABC$.

Step 1 Use the Law of Cosines to find the missing side length.

$$b^2 = a^2 + c^2 - 2ac \cos B$$

Law of Cosines

$$b^2 = 7^2 + 5^2 - 2(7)(5) \cos 36^\circ \quad a = 7, c = 5, B = 36^\circ$$

$$b^2 \approx 17.4 \quad \text{Use a calculator to simplify.}$$

$$b \approx 4.2 \quad \text{Take the square root of each side.}$$

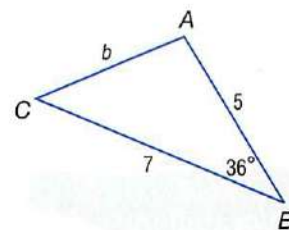

Step 2 Use the Law of Sines to find a missing angle measure.

$$\frac{\sin A}{7} \approx \frac{\sin 36^\circ}{4.2} \quad \frac{\sin A}{a} = \frac{\sin B}{b}$$

$$\sin A \approx \frac{7 \sin 36^\circ}{4.2} \quad \text{Multiply each side by 7.}$$

$$A \approx 78^\circ \quad \text{Use the } \sin^{-1} \text{ function.}$$

Step 3 Find the measure of the other angle.
 $m\angle C \approx 180^\circ - (36^\circ + 78^\circ)$ or 66°

So, $b \approx 4.2$, $A \approx 78^\circ$, and $C \approx 66^\circ$.

Check Your Progress

- Solve $\triangle FGH$ if $G = 82^\circ$, $f = 6$, and $h = 4$.

When you are only given the three side lengths of a triangle, you can solve it by using the Law of Cosines. The first step is to find the measure of the largest angle. This is done to ensure the other two angles are acute when using the Law of Sines.

EXAMPLE 2 Solve a Triangle Given Three Sides

Solve $\triangle ABC$.

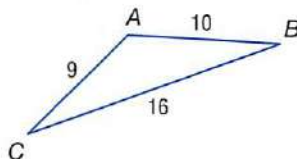

Step 1 Use the Law of Cosines to find the measure of the largest angle, $\angle A$.

$$\begin{aligned} a^2 &= b^2 + c^2 - 2bc \cos A \\ 16^2 &= 9^2 + 10^2 - 2(9)(10) \cos A \\ 16^2 - 9^2 - 10^2 &= -2(9)(10) \cos A \\ \frac{16^2 - 9^2 - 10^2}{-2(9)(10)} &= \cos A \\ -0.4167 &\approx \cos A \\ 115^\circ &\approx A \end{aligned}$$

Law of Cosines

$$a = 16, b = 9, \text{ and } c = 10$$

Subtract 9^2 and 10^2 from each side.

Divide each side by $-2(9)(10)$.

Use a calculator to simplify.

Use the \cos^{-1} function.

Step 2 Use the Law of Sines to find the measure of $\angle B$.

$$\begin{aligned} \frac{\sin B}{9} &\approx \frac{\sin 115^\circ}{16} & \frac{\sin B}{b} &= \frac{\sin A}{a} \\ \sin B &\approx \frac{9 \sin 115^\circ}{16} & \text{Multiply each side by 9.} \\ \sin B &\approx 0.5098 & \text{Use a calculator.} \\ B &\approx 31^\circ & \text{Use the } \sin^{-1} \text{ function.} \end{aligned}$$

Step 3 Find the measure of $\angle C$.

$$m\angle C \approx 180^\circ - (115^\circ + 31^\circ) \text{ or about } 34^\circ$$

So, $A \approx 115^\circ$, $B \approx 31^\circ$, and $C \approx 34^\circ$.

Check Your Progress

- Solve $\triangle ABC$ if $a = 5$, $b = 11$, and $c = 8$.

Personal Tutor glencoe.com

StudyTip

Alternative Method

After finding b in Step 1, the Law of Cosines could be used again to find the measure of a second angle.

Review Vocabulary

oblique a triangle that has no right angle

Choose a Method to Solve Triangles You can use the Law of Sines and the Law of Cosines to solve problems involving oblique triangles. You need to know the measure of at least one side and any two other parts. If the triangle has a solution, you must decide whether to use the Law of Sines or the Law of Cosines to begin solving it.

Concept Summary

Solving Oblique Triangles

For Your
FOLDABLE

Given	Begin by Using
two angles and any sides	Law of Sines
two sides and an angle opposite one of them	Law of Sines
two sides and their included angle	Law of Cosines
three sides	Law of Cosines



Real-World EXAMPLE 3 Use the Law of Cosines

SCUBA DIVING A scuba diver looks up 20° and sees a turtle 9 feet away. She looks down 40° and sees a blue parrotfish 12 feet away. How far apart are the turtle and the blue parrotfish?

Understand You know the angles formed when the scuba diver looks up and when she looks down. You also know how far away the turtle and the blue parrotfish are from the scuba diver.

Plan Use the information to draw and label a diagram. Since two sides and the included angle of a triangle are given, you can use the Law of Cosines to solve the problem.

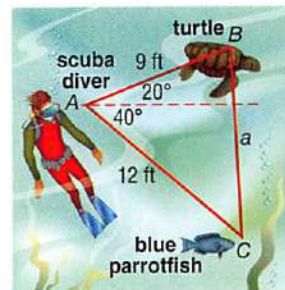

Solve

$$a^2 = b^2 + c^2 - 2bc \cos A$$

$$a^2 = 12^2 + 9^2 - 2(12)(9) \cos 60$$

$$a^2 = 117$$

$$a \approx 10.8$$

Law of Cosines
 $b = 12$, $c = 9$, and $A = 60$
 Use a calculator.
 Find the positive value of a .

So, the turtle and the blue parrotfish are about 10.8 feet apart.

Check Using the Law of Sines, you can find that $B \approx 74^\circ$ and $C \approx 46^\circ$. Since $C < A < B$ and $c < a < b$, the solution is reasonable.

Real-World Link

The record for the deepest seawater scuba dive was 1044 feet, made by a scuba diver in the Red Sea.

Source: Guinness Book of World Records

Check Your Progress

3. **MARATHONS** Amelia ran 6 miles in one direction. She then turned 79° and ran 7 miles. At the end of the run, how far was Amelia from her starting point?

Personal Tutor glencoe.com

Check Your Understanding

Examples 1 and 2
pp. 841–842

Solve each triangle. Round side lengths to the nearest tenth and angle measures to the nearest degree.

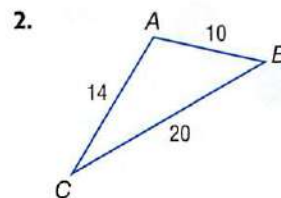
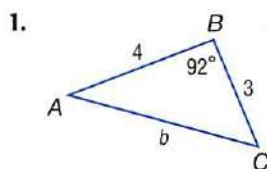

3. $a = 5$, $b = 8$, $c = 12$

4. $B = 110^\circ$, $a = 6$, $c = 3$

Example 3
p. 843

Determine whether each triangle should be solved by beginning with the Law of Sines or the Law of Cosines. Then solve the triangle.

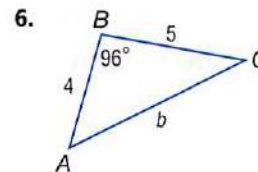
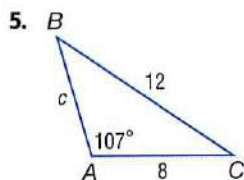

7. In $\triangle RST$, $R = 35^\circ$, $s = 16$, and $t = 9$.

8. **FOOTBALL** In a football game, the quarterback is 20 yards from Receiver A. He turns 40° to see Receiver B, who is 16 yards away. How far apart are the two receivers?

Practice and Problem Solving

 = **Step-by-Step Solutions** begin on page R20.
Extra Practice begins on page 947.

Examples 1 and 2
pp. 841–842

Solve each triangle. Round side lengths to the nearest tenth and angle measures to the nearest degree.

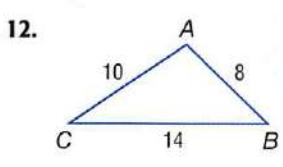
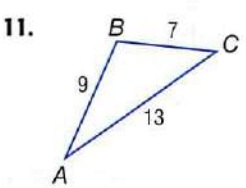
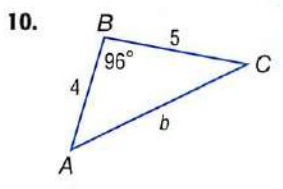
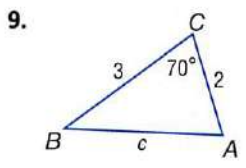

13. $A = 116^\circ, b = 5, c = 3$
 15. $f = 10, g = 11, h = 4$

14. $C = 80^\circ, a = 9, b = 2$
 16. $w = 20, x = 13, y = 12$

Example 3
p. 843

Determine whether each triangle should be solved by beginning with the Law of Sines or the Law of Cosines. Then solve the triangle.

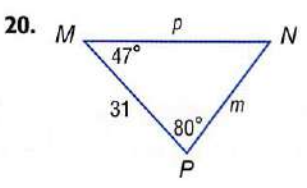
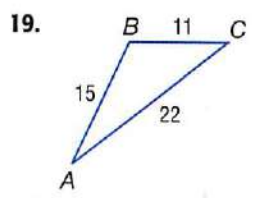
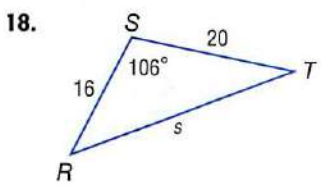
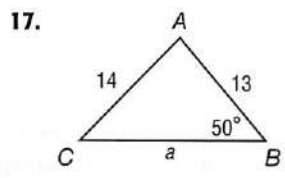

21. In $\triangle ABC, C = 84^\circ, c = 7,$ and $a = 2.$ 22. In $\triangle HJK, h = 18, j = 10,$ and $k = 23.$

23. EXPLORATION Refer to the beginning of the lesson. Find the distance between the ship and the shipwreck. Round to the nearest tenth.

24. **GEOMETRY** A parallelogram has side lengths 8 centimeters and 12 centimeters. One angle between them measures $42^\circ.$ To the nearest tenth, what is the length of the shorter diagonal?

25. **RACING** A triangular cross-country course has side lengths 1.8 kilometers, 2 kilometers, and 1.2 kilometers. What are the angles formed between each pair of sides?

26. **SURVEYING** A triangular plot of farm land measures 0.9 by 0.5 by 1.25 miles.
 a. If the plot of land is fenced on the border, what will be the angles at which the fences of the three sides meet? Round to the nearest degree.
 b. What is the area of the plot of land?

27. **LAND** Some land is in the shape of a triangle. The distances between each vertex of the triangle are 140 yd, 210 yd and 300 yd, respectively. Use the Law of Cosines to find the area of the land to the nearest square yard.

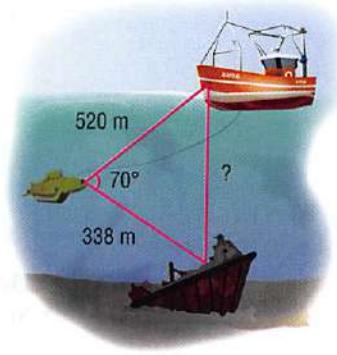

Problem-SolvingTip

Work Backward
 When the information needed to solve a problem is not given in an organized manner, begin with what you need to find and arrange the information from end to beginning.

StudyTip

Rounding Sometimes rounding can lead to ambiguous answers, such as a triangle appearing to be 181 degrees.

28. **RIDES** Two bumper cars at an amusement park ride collide as shown below.

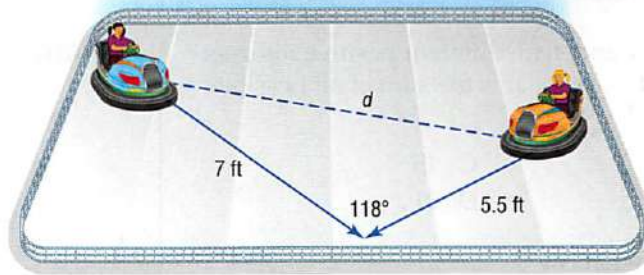

- a. How far apart d were the two cars before they collided?
 b. Before the collision, a third car was 10 feet from car 1 and 13 feet from car 2. Describe the angles formed by cars 1, 2, and 3 before the collision.
29. **PICNICS** A triangular picnic area is 11 yards by 14 yards by 10 yards.
- a. Sketch and label a drawing to represent the picnic area.
 b. Describe how you could find the area of the picnic area.
 c. What is the area? Round to the nearest tenth.

30. **WATERSPORTS** A person on a personal watercraft makes a trip from point A to point B to point C traveling 28 miles per hour. She then returns from point C back to her starting point traveling 35 miles per hour. How many minutes did the entire trip take? Round to the nearest tenth.

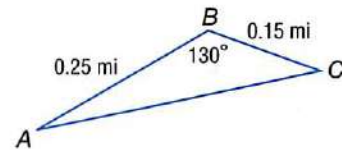

Solve each triangle. Round side lengths to the nearest tenth and angle measures to the nearest degree.

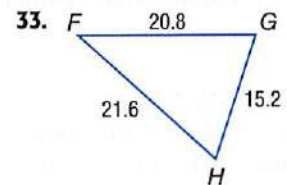
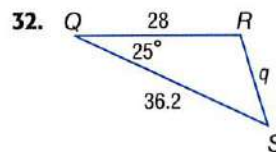
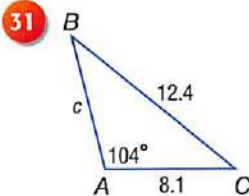

Real-World Link



Personal watercraft were first developed in the 1960s and became popular in the mid 1970s. Today, personal watercraft account for about $\frac{1}{3}$ of all powerboat sales.

Source: Personal Watercraft Industry Association

H.O.T. Problems

Use **H**igher-**O**rders **T**hinking Skills

34. **CHALLENGE** Use the figure and the Pythagorean Theorem to derive the Law of Cosines. Use the hints below.
- First, use the Pythagorean Theorem for $\triangle DBC$.
 - In $\triangle ADB$, $c^2 = x^2 + h^2$.
 - $\cos A = \frac{x}{c}$

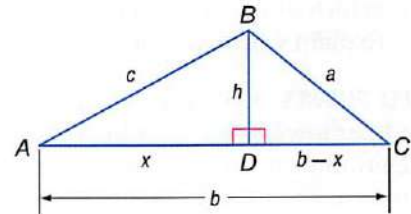

35. **REASONING** Three sides of a triangle measure 10.6 centimeters, 8 centimeters, and 14.5 centimeters. Explain how to find the measure of the largest angle. Then find the measure of the angle to the nearest degree.
36. **OPEN ENDED** Find three measures of a triangle so that the Law of Cosines can be used to solve the triangle. Then solve the triangle.
37. **WRITING IN MATH** Compare the circumstances in which you can use the Law of Sines and the Law of Cosines to solve a triangle.

Standardized Test Practice

38. **SAT/ACT** If c and d are different positive integers and $4c + d = 26$, what is the sum of all possible values of c ?

- A 6 C 15
B 10 D 21

39. If $6^y = 21$, what is y ?

- F $\log 12 - \log 6$ H $\frac{\log 6}{\log 21}$
G $\frac{\log 21}{\log 6}$ J $\log\left(\frac{6}{21}\right)$

40. **GEOMETRY** Find the perimeter of the figure.

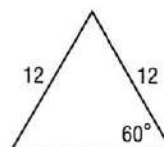

- A 24 B 30 C 36 D 48

41. **SHORT RESPONSE** Solve the equation below for x .

$$\frac{1}{x-1} + \frac{5}{8} = \frac{23}{6x}$$

Spiral Review

Find the area of $\triangle ABC$ to the nearest tenth. (Lesson 13-4)

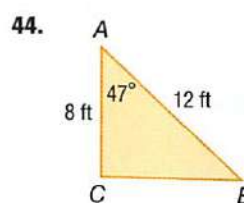
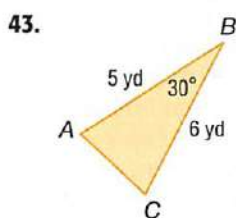
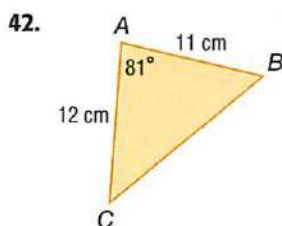

The terminal side of θ in standard position contains each point. Find the exact values of the six trigonometric functions of θ . (Lesson 13-3)

45. $(8, 5)$

46. $(-4, -2)$

47. $(6, -9)$

48. **EDUCATION** The Millersburg school board is negotiating a pay raise with the teachers' union. Three of the administrators have salaries of \$90,000 each. However, a majority of the teachers have salaries of about \$45,000 per year. (Lesson 12-2)

- You are a member of the school board and would like to show that the current salaries are reasonable. Would you quote the mean, median, or mode as the "average" salary to justify your claim? Explain.
- You are the head of the teachers' union and maintain that a pay raise is in order. Which of the mean, median, or mode would you quote to justify your claim? Explain your reasoning.

49. **CELL PHONES** A person using a cell phone can be located with respect to three cellular towers. In a coordinate system where a unit represents one mile, a caller is determined to be 50 miles from the tower at the origin. He is also 40 miles from a tower at $(0, 30)$ and 13 miles from a tower at $(35, 18)$. Where is the caller? (Lesson 10-7)

Without writing the equation in standard form, state whether the graph of each equation is a *parabola*, *circle*, *ellipse*, or *hyperbola*. (Lesson 10-6)

50. $x^2 + y^2 - 8x - 6y + 5 = 0$

51. $3x^2 - 2y^2 + 32y - 134 = 0$

52. $y^2 + 18y - 2x = -84$

Skills Review

Sketch each angle. Then find its reference angle. (Lesson 13-3)

53. 245°

54. -15°

55. $\frac{5}{4}\pi$

Solve $\triangle XYZ$ by using the given measurements. Round measures of sides to the nearest tenth and measures of angles to the nearest degree. (Lesson 13-1)

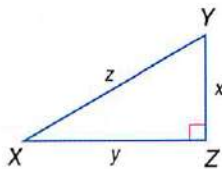

- $Y = 65^\circ, x = 16$
- $X = 25^\circ, x = 8$
- Find the values of the six trigonometric functions for angle θ . (Lesson 13-1)

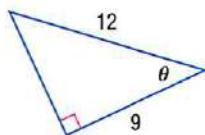

- Draw an angle measuring -80° in standard position. (Lesson 13-2)

Rewrite each degree measure in radians and each radian measure in degrees. (Lesson 13-2)

- 215°
- -350°
- $\frac{8\pi}{5}$
- $\frac{9\pi}{2}$

- MULTIPLE CHOICE** What is the length of the arc below rounded to the nearest tenth? (Lesson 13-2)

- A 4.2 cm
- B 17.1 cm
- C 53.9 cm
- D 2638.9 cm

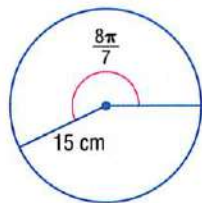

Find the exact value of each trigonometric function. (Lesson 13-3)

- $\tan \pi$
- $\cos \frac{3\pi}{4}$

The terminal side of θ in standard position contains each point. Find the exact values of the six trigonometric functions of θ . (Lesson 13-3)

- $(0, -5)$
- $(6, 8)$

- GARDEN** Lana has a garden in the shape of a triangle as pictured below. She wants to fill the garden with top soil. What is the area of the triangle? (Lesson 13-4)

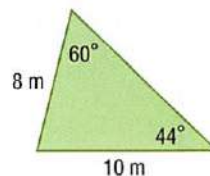

Determine whether each triangle has *no* solution, *one* solution, or *two* solutions. Then solve the triangle. Round side lengths to the nearest tenth and angle measures the nearest degree. (Lesson 13-4)

- $A = 38^\circ, a = 18, c = 25$
- $A = 65^\circ, a = 5, b = 7$
- $A = 115^\circ, a = 12, b = 8$

Solve each triangle. Round side lengths to the nearest tenth and angle measures to the nearest degree. (Lesson 13-5)

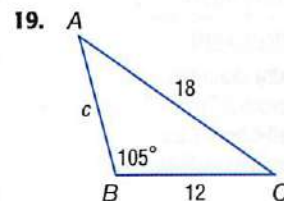
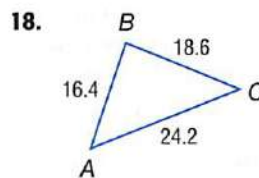

- Eric and Zach are camping. Erik leaves Zach at the campsite and walks 4.5 miles. He then turns at a 120° angle and walks another 2.5 miles. If Eric were to walk directly back to Zach, how far would he walk? (Lesson 13-5)

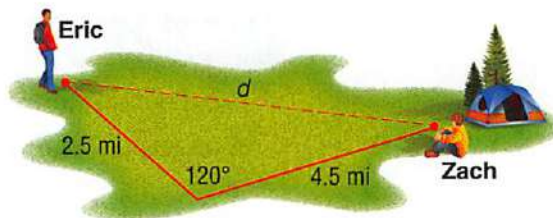

- MULTIPLE CHOICE** Suppose θ is an angle in standard position with $\cos \theta > 0$. In which quadrant(s) does the terminal side of θ lie? (Lesson 13-2)

- F I
- G II
- H III
- J I and IV

Circular Functions

Why?

The pedals on a bicycle rotate as the bike is being ridden. The height of a pedal is a function of time, as shown in the figure at the right.

Notice that the pedal makes one complete rotation every two seconds.

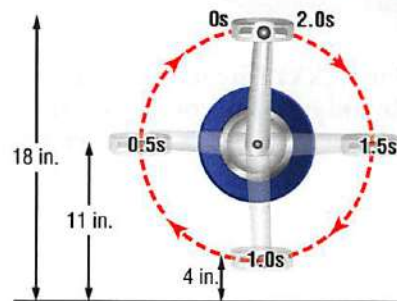

Circular Functions A **unit circle** is a circle with a radius of 1 unit centered at the origin on the coordinate plane. You can use a point P on the unit circle to generalize sine and cosine functions.

$$\sin \theta = \frac{y}{r} = \frac{y}{1} \text{ or } y \quad \cos \theta = \frac{x}{r} = \frac{x}{1} \text{ or } x$$

So, the values of $\sin \theta$ and $\cos \theta$ are the y -coordinate and x -coordinate, respectively, of the point where the terminal side of θ intersects the unit circle.

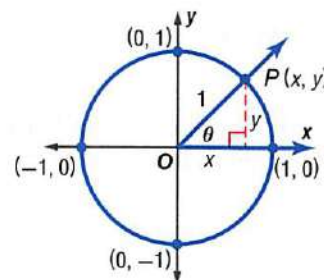

Then

You evaluated trigonometric functions using reference angles. (Lesson 13-3)

Now

- Find values of trigonometric functions based on the unit circle.
- Use the properties of periodic functions to evaluate trigonometric functions.

New Vocabulary

unit circle
circular function
periodic function
cycle
period

Math Online

glencoe.com

- Extra Examples
- Personal Tutor
- Self-Check Quiz
- Homework Help



Key Concept

Functions on a Unit Circle

For Your

FOLDABLE

Words If the terminal side of an angle θ in standard position intersects the unit circle at $P(x, y)$, then $\cos \theta = x$ and $\sin \theta = y$.

Symbols $P(x, y) = P(\cos \theta, \sin \theta)$

Example If $\theta = 120^\circ$,
 $P(x, y) = P(\cos 120^\circ, \sin 120^\circ)$.

Model

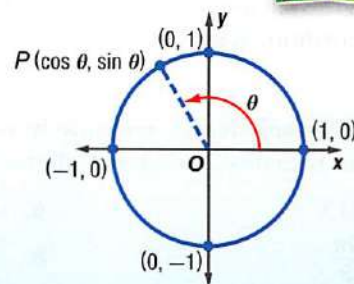

Both $\cos \theta = x$ and $\sin \theta = y$ are functions of θ . Because they are defined using a unit circle, they are called **circular functions**.

EXAMPLE 1 Find Sine and Cosine Given a Point on the Unit Circle

The terminal side of angle θ in standard position intersects the unit circle at $P\left(\frac{1}{2}, \frac{\sqrt{3}}{2}\right)$. Find $\cos \theta$ and $\sin \theta$.

$$P\left(\frac{1}{2}, \frac{\sqrt{3}}{2}\right) = P(\cos \theta, \sin \theta)$$

$$\cos \theta = \frac{1}{2} \quad \sin \theta = \frac{\sqrt{3}}{2}$$

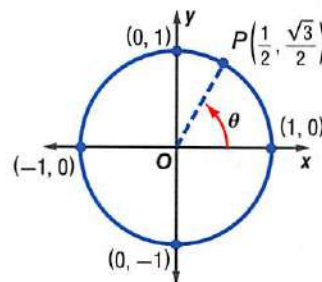

Check Your Progress

- The terminal side of angle θ in standard position intersects the unit circle at $P\left(\frac{3}{5}, -\frac{4}{5}\right)$. Find $\cos \theta$ and $\sin \theta$.

Personal Tutor glencoe.com

Periodic Functions A **periodic function** has y -values that repeat at regular intervals. One complete pattern is a **cycle**, and the horizontal length of one cycle is a **period**.

StudyTip

Cycles A cycle can begin at any point on the graph of a periodic function. In Example 2, if the beginning of the cycle is at $\frac{\pi}{2}$, then the pattern repeats at $\frac{3\pi}{2}$. The period is $\frac{3\pi}{2} - \frac{\pi}{2}$ or π .

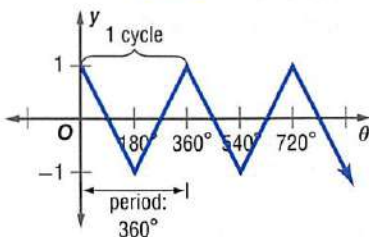

θ	y
0°	1
180°	-1
360°	1
540°	-1
720°	1

The cycle repeats every 360° .

EXAMPLE 2 Identify the Period

Determine the period of the function.

The pattern repeats at π , 2π , and so on. So, the period is π .

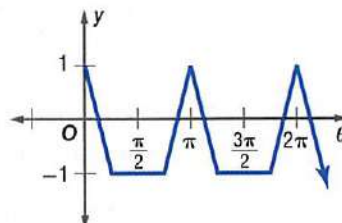

Check Your Progress

- Graph a function with a period of 4.

[Personal Tutor glencoe.com](http://glencoe.com)



Real-World Link

Most competitive cyclists pedal at rates of more than 200 rotations per minute. Most other people pedal at between 90 and 120 rotations per minute.

Source: SpringerLink

The rotations of wheels, pedals, carousels, and objects in space are all periodic.

Real-World EXAMPLE 3 Use Trigonometric Functions

CYCLING Refer to the beginning of the lesson. The height of a bicycle pedal varies periodically as a function of time, as shown in the figure.

- Make a table showing the height of a bicycle pedal at 0, 0.5, 1.0, 1.5, 2.0, 2.5, and 3.0 seconds.

Time (s)	Height (in.)
0	18
0.5	11
1.0	4
1.5	11
2.0	18
2.5	11
3.0	4

At 0 seconds, the pedal is 18 inches high. At 0.5 second, the pedal is 11 inches high. At 1.0 second, the pedal is 4 inches high, and so on.

- Identify the period of the function.

The period is the time it takes to complete one rotation. So, the period is 2 seconds.

- Graph the function. Let the horizontal axis represent the time t and the vertical axis represent the height h in inches that the pedal is from the ground.

The maximum height of the pedal is 18 inches, and the minimum height is 4 inches. Because the period of the function is 2 seconds, the pattern of the graph repeats in intervals of 2 seconds.

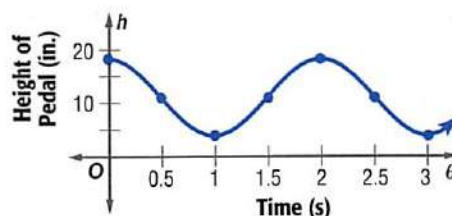

Check Your Progress

- CYCLING** Another cyclist pedals the same bike at a rate of 1 revolution per second.
 - Make a table showing the height of a bicycle pedal at times 0, 0.5, 1.0, 1.5, 2.0, 2.5, and 3.0 seconds.
 - Identify the period and graph the function.

[Personal Tutor glencoe.com](http://glencoe.com)

StudyTip

Sine and Cosine

To help you remember that for (x, y) on a unit circle, $x = \cos \theta$ and $y = \sin \theta$, notice that alphabetically x comes before y and *cosine* comes before *sine*.

The exact values of $\cos \theta$ and $\sin \theta$ for special angles are shown on the unit circle at the right. The cosine values are the x -coordinates of the points on the unit circle, and the sine values are the y -coordinates.

You can use this information to graph the sine and cosine functions. Let the horizontal axis represent the values of θ and the vertical axis represent the values of $\sin \theta$ or $\cos \theta$.

The cycles of the sine and cosine functions repeat every 360° . So, they are periodic functions. The period of each function is 360° or 2π .

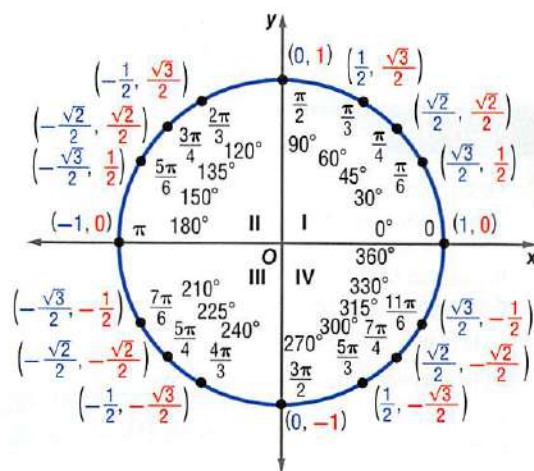

Consider the points on the unit circle for $\theta = 45^\circ$, $\theta = 150^\circ$, and $\theta = 270^\circ$.

$$(\cos 45^\circ, \sin 45^\circ) = \left(\frac{\sqrt{2}}{2}, \frac{\sqrt{2}}{2}\right)$$

$$(\cos 150^\circ, \sin 150^\circ) = \left(-\frac{\sqrt{3}}{2}, \frac{1}{2}\right)$$

$$(\cos 270^\circ, \sin 270^\circ) = (0, -1)$$

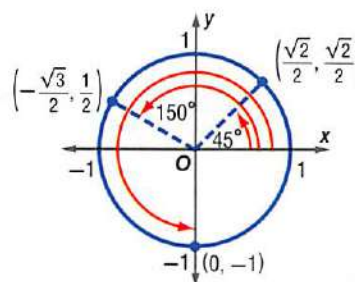

StudyTip

Radians The sine and cosine functions can also be graphed using radians as the units on the θ -axis.

These points can also be shown on the graphs of the sine and cosine functions.

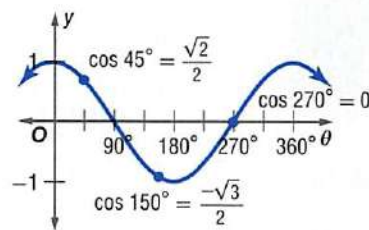
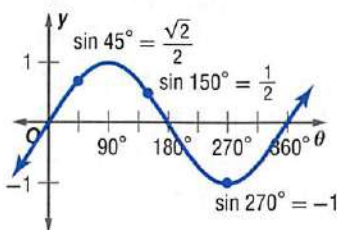

Since the period of the sine and cosine functions is 360° , the values repeat every 360° . So, $\sin(x + 360^\circ) = \sin x$, and $\cos(x + 360^\circ) = \cos x$.

EXAMPLE 4 Evaluate Trigonometric Functions

Find the exact value of each function.

a. $\cos 480^\circ$

$$\begin{aligned} \cos 480^\circ &= \cos(120^\circ + 360^\circ) \\ &= \cos 120^\circ \\ &= -\frac{1}{2} \end{aligned}$$

b. $\sin \frac{11\pi}{4}$

$$\begin{aligned} \sin \frac{11\pi}{4} &= \sin\left(\frac{3\pi}{4} + \frac{8\pi}{4}\right) \\ &= \sin \frac{3\pi}{4} \\ &= \frac{\sqrt{2}}{2} \end{aligned}$$

Check Your Progress

4A. $\cos\left(-\frac{3\pi}{4}\right)$

4B. $\sin 420^\circ$

Check Your Understanding

Example 1
p. 848

The terminal side of angle θ in standard position intersects the unit circle at each point P . Find $\cos \theta$ and $\sin \theta$.

1. $P\left(\frac{15}{17}, \frac{8}{17}\right)$

2. $P\left(-\frac{\sqrt{2}}{2}, \frac{\sqrt{2}}{2}\right)$

Example 2
p. 849

Determine the period of each function.

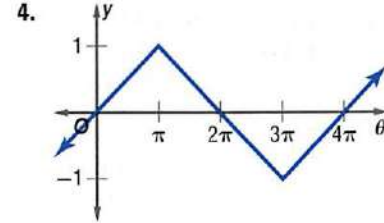
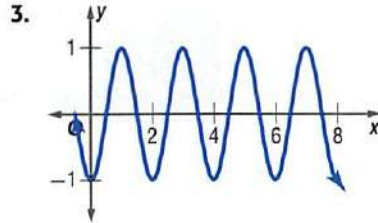

Example 3
p. 849

5. **SWINGS** The height of a swing varies periodically as the function of time. The swing goes forward and reaches its high point of 6 feet. It then goes backward and reaches 6 feet again. Its lowest point is 2 feet. The time it takes to swing from its high point to its low point is 1 second.

- How long does it take for the swing to go forward and back one time?
- Graph the height of the swing h as a function of time t .

Example 4
p. 850

Find the exact value of each function.

6. $\sin \frac{13\pi}{6}$

7. $\sin (-60^\circ)$

8. $\cos 540^\circ$

Practice and Problem Solving

= **Step-by-Step Solutions** begin on page R20.
Extra Practice begins on page 947.

Example 1
p. 848

The terminal side of angle θ in standard position intersects the unit circle at each point P . Find $\cos \theta$ and $\sin \theta$.

9. $P\left(\frac{6}{10}, -\frac{8}{10}\right)$

10. $P\left(-\frac{10}{26}, -\frac{24}{26}\right)$

11 $P\left(\frac{\sqrt{3}}{2}, \frac{1}{2}\right)$

12. $P\left(\frac{\sqrt{6}}{5}, \frac{\sqrt{19}}{5}\right)$

Example 2
p. 849

Determine the period of each function.

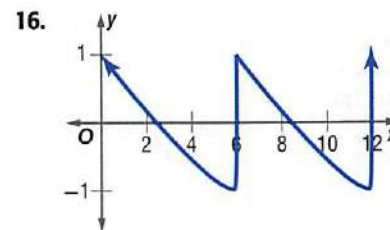
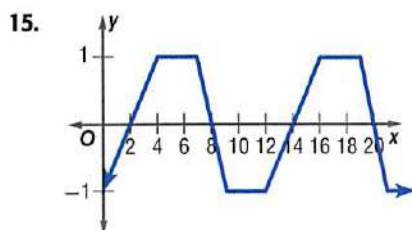
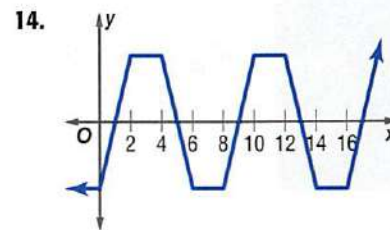
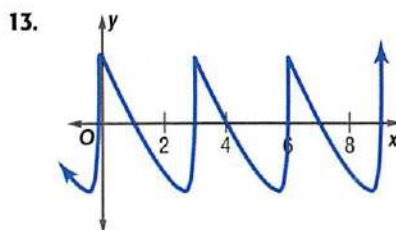

Determine the period of each function.

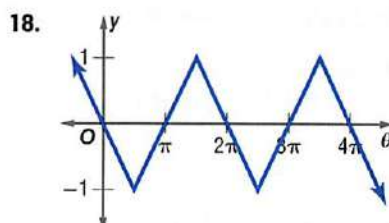
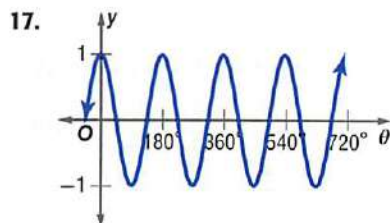

Example 3
p. 849

19. **WEATHER** In a city, the average high temperature for each month is shown in the table.

- Sketch a graph of the function representing this situation.
- Describe the period of the function.

Average High Temperatures			
Month	Temperature (°F)	Month	Temperature (°F)
Jan	36	July	85
Feb.	41	Aug.	84
Mar.	52	Sept.	78
Apr.	64	Oct.	66
May	74	Nov.	52
Jun.	82	Dec.	41

Source: The Weather Channel

Example 4
p. 850

Find the exact value of each function.

- | | | |
|----------------------------|------------------------|----------------------|
| 20. $\sin \frac{7\pi}{3}$ | 21. $\cos (-60^\circ)$ | 22. $\cos 450^\circ$ |
| 23. $\sin \frac{11\pi}{4}$ | 24. $\sin (-45^\circ)$ | 25. $\cos 570^\circ$ |

26. **ENGINES** In the engine at the right, the distance d from the piston to the center of the circle, called the *crankshaft*, is a function of the speed of the piston rod. Point R on the piston rod rotates 150 times per second.

- Identify the period of the function as a fraction of a second.
- The shortest distance d is 0.5 inch, and the longest distance is 3.5 inches. Sketch a graph of the function. Let the horizontal axis represent the time t . Let the vertical axis represent the distance d .

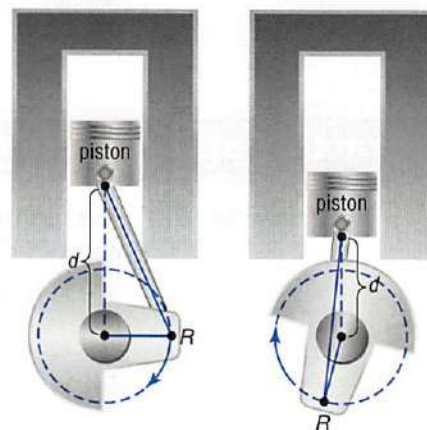

27. **TORNADOES** A tornado siren makes 2.5 rotations per minute and the beam of sound has a radius of 1 mile. Ms. Miller's house is 1 mile from the siren. The distance of the sound beam from her house varies periodically as a function of time.

- Identify the period of the function in seconds.
- Sketch a graph of the function. Let the horizontal axis represent the time t from 0 seconds to 60 seconds. Let the vertical axis represent the distance d the sound beam is from Ms. Miller's house at time t .

28. **FERRIS WHEEL** A Ferris wheel in China has a diameter of approximately 520 feet. The height of a compartment h is a function of time t . It takes about 30 seconds to make one complete revolution. Let the height at the center of the wheel represent the height at time 0. Sketch a graph of the function.



Real-World Link

Tornadoes can have whirling winds that reach 300 miles per hour. The forward speed of a tornado can reach up to 70 miles per hour.

Source: FEMA



Math History Link

Pauline Sperry (1885–1967)
Pauline Sperry was born in Peabody, Massachusetts. During the 1920s, she wrote two textbooks, *Short Course in Spherical Trigonometry* and *Plane Trigonometry*. In 1923, she became the first woman to be promoted to assistant professor in the mathematics department at Berkeley.

29. **MULTIPLE REPRESENTATIONS** The terminal side of an angle in standard position intersects the unit circle at P , as shown in the figure.

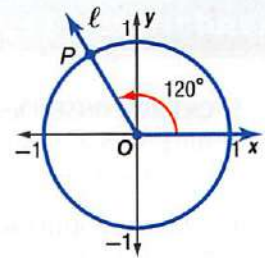

- GEOMETRIC** Copy the figure. Draw lines representing 30° , 60° , 150° , 210° , and 315° .
 - TABULAR** Use a table of values to show the slope of each line to the nearest tenth.
 - ANALYTICAL** What conclusions can you make about the relationship between the terminal side of the angle and the slope? Explain your reasoning.
30. **POGO STICK** A person is jumping up and down on a pogo stick at a constant rate. The difference between his highest and lowest points is 2 feet. He jumps 50 times per minute.
- Describe the independent variable and dependent variable of the periodic function that represents this situation. Then state the period of the function in seconds.
 - Sketch a graph of the jumper's change in height in relation to his starting point. Assume that his starting point is halfway between his highest and lowest points. Let the horizontal axis represent the time t in seconds. Let the vertical axis represent the height h .

Find the exact value of each function.

- $\cos 45^\circ - \cos 30^\circ$
- $2 \sin \frac{4\pi}{3} - 3 \cos \frac{11\pi}{6}$
- $(\sin 45^\circ)^2 + (\cos 45^\circ)^2$
- $6(\sin 30^\circ)(\sin 60^\circ)$
- $\cos\left(-\frac{2\pi}{3}\right) + \frac{1}{3} \sin 3\pi$
- $\frac{(\cos 30^\circ)(\cos 150^\circ)}{\sin 315^\circ}$

H.O.T. Problems

Use **H**igher-**O**rders **T**hinking Skills

37. **FIND THE ERROR** Francis and Benita are finding the exact value of $\cos \frac{-\pi}{3}$. Is either of them correct? Explain your reasoning.

Francis

$$\begin{aligned} \cos \frac{-\pi}{3} &= -\cos \frac{\pi}{3} \\ &= -0.5 \end{aligned}$$

Benita

$$\begin{aligned} \cos \frac{-\pi}{3} &= \cos\left(-\frac{\pi}{3} + 2\pi\right) \\ &= \cos \frac{5\pi}{3} \\ &= 0.5 \end{aligned}$$

38. **CHALLENGE** A ray has its endpoint at the origin of the coordinate plane, and point $P\left(\frac{1}{2}, -\frac{\sqrt{3}}{2}\right)$ lies on the ray. Find the angle θ formed by the positive x -axis and the ray.
39. **REASONING** Is the period of a sine curve *sometimes*, *always*, or *never* a multiple of π ? Justify your reasoning.

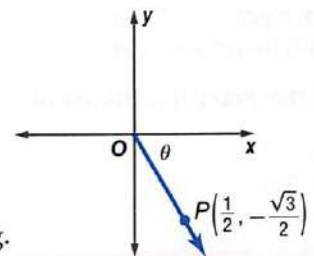

40. **OPEN ENDED** Draw the graph of a periodic function that has a maximum value of 10 and a minimum value of -10 . Describe the period of the function.
41. **WRITING IN MATH** Explain how to determine the period of a periodic function from its graph. Include a description of a cycle.

Standardized Test Practice

42. **SHORT RESPONSE** Describe the translation of the graph of $f(x) = x^2$ to the graph of $g(x) = (x + 4)^2 - 3$.

43. The rate of population decline of Hampton Cove is modeled by $P(t) = 24,000e^{-0.0064t}$, where t is time in years from this year and 24,000 is the current population. In how many years will the population be 10,000?

- A 14 B 104 C 137 D 375

44. **SAT/ACT** If $d^2 + 8 = 21$, then $d^2 - 8 =$

- F 5 G 13 H 31 J 161

45. **STATISTICS** If the average of three different positive integers is 65, what is the greatest possible value of one of the integers?

- A 192 B 193 C 194 D 195

46. **GRIDDED RESPONSE** If $8xy + 3 = 3$, what is the value of xy ?

Spiral Review

Solve each triangle. Round side lengths to the nearest tenth and angle measures to the nearest degree. (Lesson 13-5)

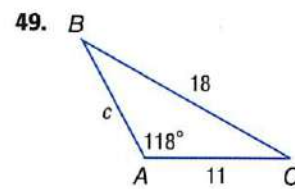
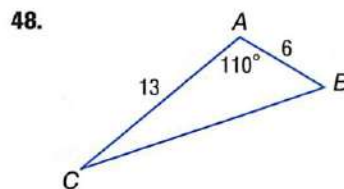
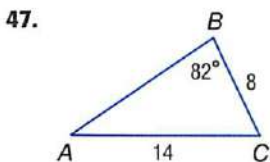

Determine whether each triangle has *no* solution, *one* solution, or *two* solutions. Then solve the triangle. Round side lengths to the nearest tenth and angle measures to the nearest degree. (Lesson 13-4)

50. $A = 72^\circ, a = 6, b = 11$

51. $A = 46^\circ, a = 10, b = 8$

52. $A = 110^\circ, a = 9, b = 5$

A binomial distribution has a 70% rate of success. There are 10 trials. (Lesson 12-7)

53. What is the probability that there will be 3 failures?

54. What is the probability that there will be at least 7 successes?

55. What is the expected number of successes?

56. **GAMES** The diagram shows the board for a game in which spheres are dropped down a chute. A pattern of nails and dividers causes the spheres to take various paths to the sections at the bottom. For each section, how many paths through the board lead to that section? (Lesson 11-6)

57. **SALARIES** Phillip's current salary is \$40,000 per year. His annual pay raise is always a percent of his salary at the time. What would his salary be if he got four consecutive 4% increases? (Lesson 11-2)

Find the exact solution(s) of each system of equations. (Lesson 10-7)

58. $y = x + 2$
 $y = x^2$

59. $4x + y^2 = 20$
 $4x^2 + y^2 = 100$

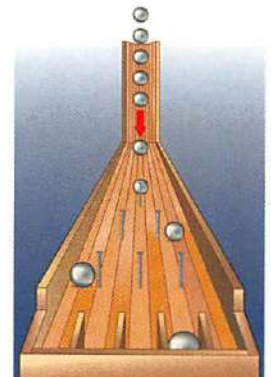

Skills Review

Simplify each expression. (Lesson 1-4)

60. $\frac{240}{1 - \frac{5}{4}}$

61. $\frac{180}{2 - \frac{1}{3}}$

62. $\frac{90}{2 - \frac{11}{4}}$

13-7

Graphing Trigonometric Functions

Why?

Visible light waves have different wavelengths or periods. Red has the longest wavelength and violet has the shortest wavelength.

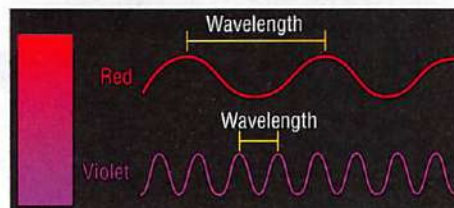

Then

You examined periodic functions. (Lesson 13-6)

Now

- Describe and graph the sine, cosine, and tangent functions.
- Describe and graph other trigonometric functions.

New Vocabulary

amplitude
frequency

Math Online

glencoe.com

- Extra Examples
- Personal Tutor
- Self-Check Quiz
- Homework Help
- Math in Motion

Sine, Cosine, and Tangent Functions Trigonometric functions can also be graphed on the coordinate plane. Recall that graphs of periodic functions have repeating patterns, or *cycles*. The horizontal length of each cycle is the *period*. The **amplitude** of the graph of a sine or cosine function equals half the difference between the maximum and minimum values of the function.

Key Concept		Sine and Cosine Functions	
			For Your FOLDABLE
Parent Function	$y = \sin \theta$	$y = \cos \theta$	
Graph			
Domain	{all real numbers}	{all real numbers}	
Range	$\{y \mid -1 \leq y \leq 1\}$	$\{y \mid -1 \leq y \leq 1\}$	
Amplitude	1	1	
Period	360°	360°	

Math in Motion, Animation glencoe.com

As with other functions, trigonometric functions can be transformed. For the graphs of $y = a \sin b\theta$ and $y = a \cos b\theta$, the amplitude = $|a|$ and the period = $\frac{360^\circ}{|b|}$.

EXAMPLE 1 Find Amplitude and Period

Find the amplitude and period of $y = 4 \cos 3\theta$.

amplitude: $|a| = |4|$ or 4

period: $\frac{360^\circ}{|b|} = \frac{360^\circ}{|3|}$ or 120°

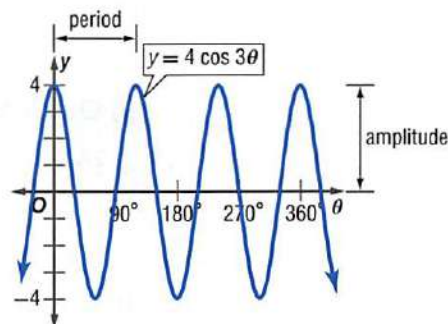

Check Your Progress

Find the amplitude and period of each function.

1A. $y = \cos \frac{1}{2}\theta$

1B. $y = 3 \sin 5\theta$

Personal Tutor glencoe.com

StudyTip

Periods In $y = a \sin b\theta$ and $y = a \cos b\theta$, b represents the number of cycles in 360° . In Example 1, the 3 in $y = 4 \cos 3\theta$ indicates that there are three cycles in 360° . So, there is one cycle in 120° .

Use the graphs of the parent functions to graph $y = a \sin b\theta$ and $y = a \cos b\theta$. Then use the amplitude and period to draw the appropriate sine and cosine curves. You can also use θ -intercepts to help you graph the functions.

The θ -intercepts of $y = a \sin b\theta$ and $y = a \cos b\theta$ in one cycle are as follows.

$y = a \sin b\theta$	$y = a \cos b\theta$
$(0, 0), \left(\frac{1}{2} \cdot \frac{360^\circ}{b}, 0\right), \left(\frac{360^\circ}{b}, 0\right)$	$\left(\frac{1}{4} \cdot \frac{360^\circ}{b}, 0\right), \left(\frac{3}{4} \cdot \frac{360^\circ}{b}, 0\right)$

StudyTip

Amplitude The graphs of $y = a \sin b\theta$ and $y = a \cos b\theta$ with amplitude of $|a|$ have maxima at $y = a$ and minima at $y = -a$.

EXAMPLE 2 Graph Sine and Cosine Functions

Graph each function.

a. $y = 2 \sin \theta$

Find the amplitude, the period, and the x -intercepts: $a = 2$ and $b = 1$.

amplitude: $|a| = |2|$ or 2 \rightarrow The graph is stretched vertically so that the maximum value is 2 and the minimum value is -2 .

period: $\frac{360^\circ}{|b|} = \frac{360^\circ}{|1|}$ or 360° \rightarrow One cycle has a length of 360° .

x -intercepts: $(0, 0)$

$$\left(\frac{1}{2} \cdot \frac{360^\circ}{b}, 0\right) = (180^\circ, 0)$$

$$\left(\frac{360^\circ}{b}, 0\right) = (360^\circ, 0)$$

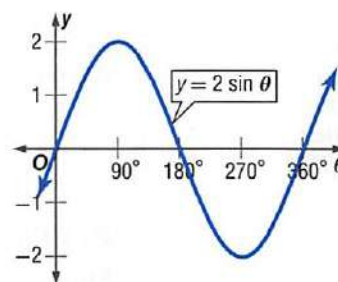

b. $y = \cos 4\theta$

amplitude: $|a| = |1|$ or 1

period: $\frac{360^\circ}{|b|} = \frac{360^\circ}{|4|}$ or 90°

x -intercepts: $\left(\frac{1}{4} \cdot \frac{360^\circ}{b}, 0\right) = (22.5^\circ, 0)$

$$\left(\frac{3}{4} \cdot \frac{360^\circ}{b}, 0\right) = (67.5^\circ, 0)$$

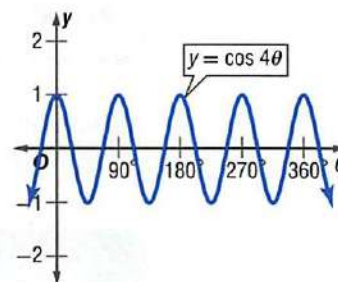

Check Your Progress

2A. $y = 3 \cos \theta$

2B. $y = \frac{1}{2} \sin 2\theta$

 glencoe.com

Trigonometric functions are useful for modeling real-world periodic motion such as electromagnetic waves or sound waves. Often these waves are described using *frequency*. **Frequency** is the number of cycles in a given unit of time.

The frequency of the graph of a function is the reciprocal of the period of the function. So, if the period of a function is $\frac{1}{100}$ second, then the frequency is 100 cycles per second.

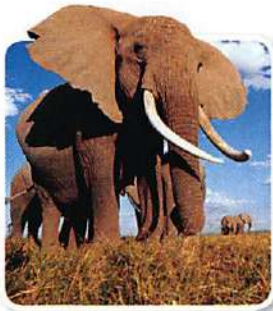

Real-World Link

Elephants are able to hear sound coming from up to 5 miles away. Humans can hear sounds with frequencies between 20 Hz and 20,000 Hz.

Source: School for Champions

Real-World EXAMPLE 3 Model Periodic Situations

SOUND Sound that has a frequency below the human range is known as *infrasound*. Elephants can hear sounds in the infrasound range, with frequencies as low as 5 hertz (Hz), or 5 cycles per second.

- a. Find the period of the function that models the sound waves.

There are 5 cycles per second, and the period is the time it takes for one cycle. So, the period is $\frac{1}{5}$ or 0.2 second.

- b. Let the amplitude equal 1 unit. Write a sine equation to represent the sound wave y as a function of time t . Then graph the equation.

$$\text{period} = \frac{2\pi}{|b|}$$

Write the relationship between the period and b .

$$0.2 = \frac{2\pi}{|b|}$$

Substitution

$$0.2|b| = 2\pi$$

Multiply each side by $|b|$.

$$b = 10\pi$$

Multiply each side by 5; b is positive.

$$y = a \sin b\theta$$

Write the general equation for the sine function.

$$y = 1 \sin 10\pi t$$

$a = 1$, $b = 10\pi$, and $\theta = t$

$$y = \sin 10\pi t$$

Simplify.

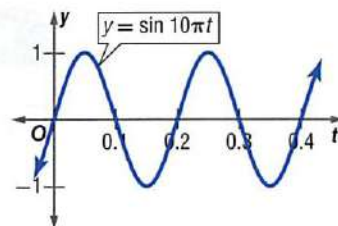

StudyTip

Amplitude and Period

Note that the amplitude affects the graph along the vertical axis, and the period affects it along the horizontal axis.

Check Your Progress

3. **SOUND** Humans can hear sounds with frequencies as low as 20 hertz.

- A. Find the period of the function.
B. Let the amplitude equal 1 unit. Write a cosine equation to model the sound waves. Then graph the equation.

Personal Tutor glencoe.com

Tangent is one of the trigonometric functions whose graphs have asymptotes.

Key Concept		Tangent Function	For Your FOLDABLE
Parent Function		$y = \tan \theta$	
Domain		$\{\theta \mid \theta \neq 90 + 180n, n \text{ is an integer}\}$	
Range		{all real numbers}	
Amplitude		undefined	
Period		180°	
θ intercepts in one cycle		$(0, 0), \left(\frac{1}{2} \cdot \frac{360^\circ}{b}, 0\right), \left(\frac{360^\circ}{b}, 0\right)$	

For the graph of $y = a \tan b\theta$, the period is $\frac{180^\circ}{|b|}$, there is no amplitude, and the asymptotes are odd multiples of $\frac{180^\circ}{2|b|}$.

StudyTip

Tangent The tangent function does not have an amplitude because it has no maximum or minimum values.

EXAMPLE 4 Graph Tangent Functions

Find the period of $y = \tan 2\theta$. Then graph the function.

$$\text{period: } \frac{180^\circ}{|b|} = \frac{180^\circ}{|2|} \text{ or } 90^\circ$$

$$\text{asymptotes: } \frac{180^\circ}{2|b|} = \frac{180^\circ}{2|2|} \text{ or } 45^\circ$$

Sketch asymptotes at $-1 \cdot 45^\circ$ or -45° , $1 \cdot 45^\circ$ or 45° , $3 \cdot 45^\circ$ or 135° , and so on.

Use $y = \tan \theta$, but draw one cycle every 90° .

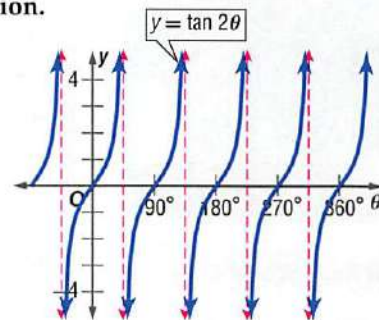

Check Your Progress

4. Find the period of $y = \frac{1}{2} \tan \theta$. Then graph the function.

Personal Tutor glencoe.com

Graphs of Other Trigonometric Functions The graphs of the cosecant, secant, and cotangent functions are related to the graphs of the sine, cosine, and tangent functions.

Key Concept

Cosecant, Secant, and Cotangent Functions

For Your
FOLDABLE

Parent Function	$y = \csc \theta$	$y = \sec \theta$	$y = \cot \theta$
Graph			
Domain	$\{\theta \mid \theta \neq 180n, n \text{ is an integer}\}$	$\{\theta \mid \theta \neq 90 + 180n, n \text{ is an integer}\}$	$\{\theta \mid \theta \neq 180n, n \text{ is an integer}\}$
Range	$\{y \mid -1 > y \text{ or } y > 1\}$	$\{y \mid -1 > y \text{ or } y > 1\}$	{all real numbers}
Amplitude	undefined	undefined	undefined
Period	360°	360°	180°

StudyTip

Reciprocal Functions

You can use the graphs of $y = \sin \theta$, $y = \cos \theta$, and $y = \tan \theta$ to graph the reciprocal functions, but these graphs are not part of the graphs of the cosecant, secant, and cotangent functions.

EXAMPLE 5 Graph Other Trigonometric Functions

Find the period of $y = 2 \sec \theta$. Then graph the function.

Since $2 \sec \theta$ is a reciprocal of $2 \cos \theta$, the graphs have the same period, 360° . The vertical asymptotes occur at the points where $2 \cos \theta = 0$. So, the asymptotes are at $\theta = 90^\circ$ and $\theta = 270^\circ$.

Sketch $y = 2 \cos \theta$ and use it to graph $y = 2 \sec \theta$.

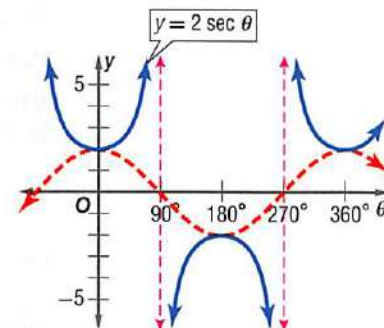

Check Your Progress

5. Find the period of $y = \csc 2\theta$. Then graph the function.

Personal Tutor glencoe.com

Check Your Understanding

Examples 1 and 2

pp. 855–856

Find the amplitude and period of each function. Then graph the function.

- $y = 4 \sin \theta$
- $y = \sin 3\theta$
- $y = \cos 2\theta$
- $y = \frac{1}{2} \cos 3\theta$

Example 3

p. 857

5. **SPIDERS** When an insect gets caught in a spider web, the web vibrates with a frequency of 14 hertz.

- Find the period of the function.
- Let the amplitude equal 1 unit. Write a sine equation to represent the vibration of the web y as a function of time t . Then graph the equation.

Examples 4 and 5

p. 858

Find the period of each function. Then graph the function.

- $y = 3 \tan \theta$
- $y = 2 \csc \theta$
- $y = \cot 2\theta$

Practice and Problem Solving

 = **Step-by-Step Solutions** begin on page R20.
Extra Practice begins on page 947.

Examples 1 and 2

pp. 855–856

Find the amplitude and period of each function. Then graph the function.

- $y = 2 \cos \theta$
- $y = \cos 3\theta$
- $y = \frac{3}{4} \cos \theta$
- $y = 4 \cos 2\theta$
- $y = 3 \sin \theta$
- $y = \cos \frac{1}{2}\theta$
- $y = \frac{3}{2} \sin \theta$
- $y = 3 \cos 2\theta$
- $y = \sin 2\theta$
- $y = \sin 4\theta$
- $y = \frac{1}{2} \sin 2\theta$
- $y = 5 \sin \frac{2}{3}\theta$

Example 3

p. 857

21. **WAVES** A boat on a lake bobs up and down with the waves. The difference between the lowest and highest points of the boat is 8 inches. The boat is at *equilibrium* when it is halfway between the lowest and highest points. Each cycle of the periodic motion lasts 3 seconds.

- Write an equation for the motion of the boat. Let h represent the height in inches and let t represent the time in seconds. Assume that the boat is at equilibrium at $t = 0$ seconds.
- Draw a graph showing the height of the boat as a function of time.

22. **ELECTRICITY** The voltage supplied by an electrical outlet is a periodic function that *oscillates*, or goes up and down, between -165 volts and 165 volts with a frequency of 50 cycles per second.

- Write an equation for the voltage V as a function of time t . Assume that at $t = 0$ seconds, the current is 165 volts.
- Graph the function.

Examples 4 and 5

p. 858

Find the period of each function. Then graph the function.

- $y = \tan \frac{1}{2}\theta$
- $y = \csc \frac{1}{2}\theta$
- $y = 3 \sec \theta$
- $y = 2 \tan \theta$
- $y = 2 \cot \theta$
- $y = \sec \frac{1}{3}\theta$



Real-World Link

Of all of the music lessons that teens take, piano lessons are the most popular.

Source: *Piano Magazine*

29. EARTHQUAKES A seismic station detects an earthquake wave that has a frequency of 0.5 hertz and an amplitude of 1 meter.

- Write an equation involving sine to represent the height of the wave h as a function of time t . Assume that the equilibrium point of the wave, $h = 0$, is halfway between the lowest and highest points.
- Graph the function. Then determine the height of the wave after 20.5 seconds.

30. PHYSICS An object is attached to a spring as shown at the right. It oscillates according to the equation $y = 20 \cos \pi t$, where y is the distance in centimeters from its equilibrium position at time t .



- Describe the motion of the object by finding the following: the amplitude in centimeters, the frequency in vibrations per second, and the period in seconds.
- Find the distance of the object from its equilibrium position at $t = \frac{1}{4}$ second.
- The equation $v = (-20 \text{ cm})(\pi \text{ rad/s}) \cdot \sin(\pi \text{ rad/s} \cdot t)$ represents the velocity v of the object at time t . Find the velocity at $t = \frac{1}{4}$ second.

31. PIANOS A piano string vibrates at a frequency of 130 hertz.

- Write and graph an equation using cosine to model the vibration of the string y as a function of time t . Let the amplitude equal 1 unit.
- Suppose the frequency of the vibration doubles. Do the amplitude and period increase, decrease, or remain the same? Explain.

Find the amplitude, if it exists, and period of each function. Then graph the function.

32. $y = 3 \sin \frac{2}{3}\theta$

33. $y = \frac{1}{2} \cos \frac{3}{4}\theta$

34. $y = 2 \tan \frac{1}{2}\theta$

35. $y = 2 \sec \frac{4}{5}\theta$

36. $y = 5 \csc 3\theta$

37. $y = 2 \cot 6\theta$

Identify the period of the graph and write an equation for each function.

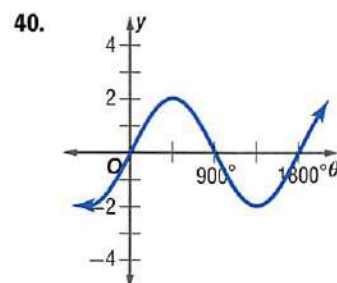
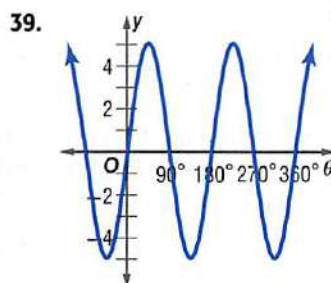
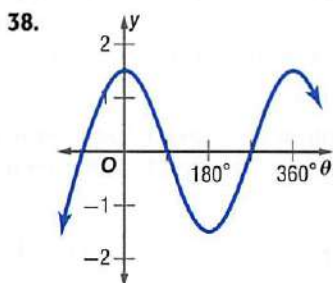

H.O.T. Problems

Use **H**igher-**O**rders **T**hinking Skills

- CHALLENGE** Describe the domain and range of $y = a \cos \theta$ and $y = a \sec \theta$, where a is any positive real number.
- REASONING** Compare and contrast the graphs of $y = \frac{1}{2} \sin \theta$ and $y = \sin \frac{1}{2}\theta$.
- OPEN ENDED** Write a trigonometric function that has an amplitude of 3 and a period of 180° . Then graph the function.
- WRITING IN MATH** Explain how to find the amplitude of $y = -2 \sin \theta$, and describe how the negative coefficient affects the graph.

Standardized Test Practice

45. **SHORT RESPONSE** Find the 100,001st term of the sequence.

13, 20, 27, 34, 41, ...

46. **STATISTICS** You bowled five games and had the following scores: 143, 171, 167, 133, and 156. What was your average?

A 147 B 153 C 154 D 156

47. Your city had a population of 312,430 ten years ago. If its current population is 418,270, by what percentage has it grown over the past 10 years?

F 25% G 34% H 66% J 75%

48. **SAT/ACT** If $h + 4 = b - 3$, then $(h - 2)^2 =$

A $h^2 + 4$ C $b^2 - 14b + 49$
 B $b^2 - 18b + 81$ D $b^2 - 10b + 25$

Spiral Review

Find the exact value of each expression. (Lesson 13-6)

49. $\cos 120^\circ - \sin 30^\circ$

50. $3(\sin 45^\circ)(\sin 60^\circ)$

51. $4 \sin \frac{4\pi}{3} - 2 \cos \frac{\pi}{6}$

Solve each triangle. Round side lengths to the nearest tenth and angle measures to the nearest degree. (Lesson 13-5)

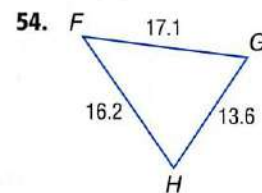
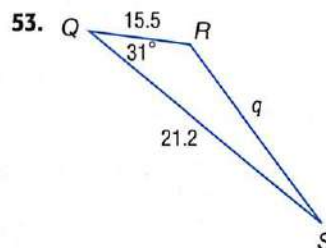
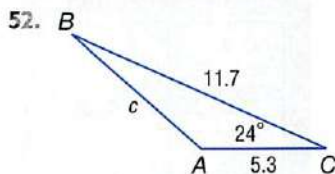

A bag contains 12 blue marbles, 9 red marbles, and 8 green marbles. The marbles are drawn one at a time. Find each probability. (Lesson 12-6)

55. The second marble is blue, given that the first marble is green and is replaced.
 56. The third marble is green, given that the first two are red and blue and not replaced.
 57. The third marble is red, given that the first two are red and not replaced.
 58. **BANKING** Rita has deposited \$1000 in a bank account. At the end of each year, the bank posts interest to her account in the amount of 3% of the balance, but then takes out a \$10 annual fee. (Lesson 11-6)
- Let b_0 be the amount Rita deposited. Write a recursive equation for the balance b_n in her account at the end of n years.
 - Find the balance in the account after four years.

Write an equation for an ellipse that satisfies each set of conditions. (Lesson 10-4)

59. center at (6, 3), focus at (2, 3), co-vertex at (6, 1)
 60. foci at (2, 1) and (2, 13), co-vertex at (5, 7)

Skills Review

Graph each function. (Lesson 5-7)

61. $f(x) = 2(x - 3)^2 - 4$

62. $f(x) = \frac{1}{3}(x + 5)^2 + 2$

63. $f(x) = -3(x + 6)^2 + 7$

Objective

Use a graphing calculator to transform graphs of trigonometric functions.

You can use a TI-83/84 Plus graphing calculator to explore transformations of the graphs of trigonometric functions.

ACTIVITY

- Step 1** Graph $y = \sin \theta$, $y = \sin \theta + 2$, and $y = \sin \theta - 3$ on the same coordinate plane. Let $Y1 = \sin \theta$, $Y2 = \sin \theta + 2$, and $Y3 = \sin \theta - 3$.

KEYSTROKES: $Y=$ $\boxed{\text{SIN}}$ $\boxed{X,T,\theta,n}$ $\boxed{)}$ $\boxed{\text{ENTER}}$
 $\boxed{\text{SIN}}$ $\boxed{X,T,\theta,n}$ $\boxed{)}$ $\boxed{+}$ $\boxed{2}$ $\boxed{\text{ENTER}}$
 $\boxed{\text{SIN}}$ $\boxed{X,T,\theta,n}$ $\boxed{)}$ $\boxed{-}$ $\boxed{3}$ $\boxed{\text{GRAPH}}$

Describe the relationship among the graphs.

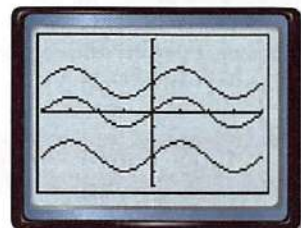

- Step 2** Graph $y = \sin \theta$, $y = \sin(\theta + 45^\circ)$, and $y = \sin(\theta - 90^\circ)$ on the same coordinate plane. Let $Y1 = \sin \theta$, $Y2 = \sin(\theta + 45^\circ)$, and $Y3 = \sin(\theta - 90^\circ)$. **Be sure to clear the entries from Step 1.**

KEYSTROKES: $Y=$ $\boxed{\text{SIN}}$ $\boxed{X,T,\theta,n}$ $\boxed{)}$ $\boxed{\text{ENTER}}$
 $\boxed{\text{SIN}}$ $\boxed{X,T,\theta,n}$ $\boxed{+}$ $\boxed{45}$ $\boxed{)}$ $\boxed{\text{ENTER}}$
 $\boxed{\text{SIN}}$ $\boxed{X,T,\theta,n}$ $\boxed{-}$ $\boxed{90}$ $\boxed{)}$ $\boxed{\text{GRAPH}}$

Describe the relationship among the graphs.

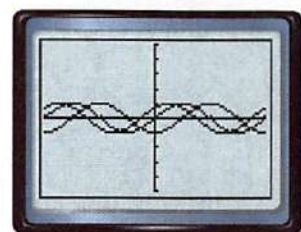
**Model and Analyze**

Repeat the activity for the cosine and tangent functions.

1. What is the effect of adding a constant to a trigonometric function?
2. What is the effect of adding a constant to θ in a trigonometric function?

Repeat the activity for each of the following. Describe the relationship between each pair of graphs.

3. $y = \sin \theta + 4$

$y = \sin(2\theta) + 4$

4. $y = \cos\left(\frac{1}{2}\theta\right)$

$y = \cos\left(\frac{1}{2}(\theta + 45^\circ)\right)$

5. $y = 2 \sin \theta$

$y = 2 \sin \theta - 1$

6. $y = \cos \theta - 3$

$y = \cos(\theta - 90^\circ) - 3$

7. Write a general equation for the sine, cosine, and tangent functions after changes in amplitude a , period b , horizontal position h , and vertical position k .

Translations of Trigonometric Graphs

Then

You translated exponential functions. (Lesson 8-1)

Now

- Graph horizontal translations of trigonometric graphs and find phase shifts.
- Graph vertical translations of trigonometric graphs.

New Vocabulary

phase shift
vertical shift
midline

Math Online

glencoe.com

- Extra Examples
- Personal Tutor
- Self-Check Quiz
- Homework Help
- Math in Motion

Why?

The graphs at the right represent the waves in a bay during high and low tides. Notice that the shape of the waves does not change.

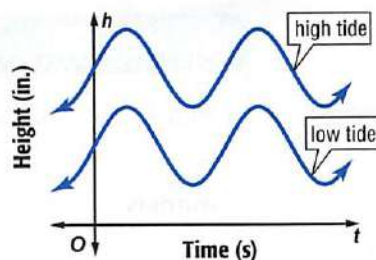

Horizontal Translations Recall that a *translation* occurs when a figure is moved from one location to another on the coordinate plane without changing its orientation. A horizontal translation of a periodic function is called a **phase shift**.

Key Concept

Phase Shift

For Your FOLDABLE

Words The phase shift of the functions $y = a \sin b(\theta - h)$, $y = a \cos b(\theta - h)$, and $y = a \tan b(\theta - h)$ is h , where $b > 0$.

Models

$y = \sin(\theta - h), h > 0$

$y = \sin \theta$

$y = \sin(\theta - h), h < 0$

$y = \sin \theta$

If $h > 0$, the shift is h units to the right.

If $h < 0$, the shift is h units to the left.

Examples $y = \cos(\theta - 90^\circ)$ The phase shift is 90° to the right.
 $y = \tan(\theta + 30^\circ)$ The phase shift is 30° to the left.

▶ **Math in Motion, Animation** glencoe.com

The secant, cosecant, and cotangent can be graphed using the same rules.

EXAMPLE 1 Graph Horizontal Translations

State the amplitude, period, and phase shift for $y = \sin(\theta - 90^\circ)$. Then graph the function.

amplitude: $a = 1$

period: $\frac{360^\circ}{|b|} = \frac{360^\circ}{1}$ or 360°

phase shift: $h = 90^\circ$

Graph $y = \sin \theta$ shifted 90° to the right.

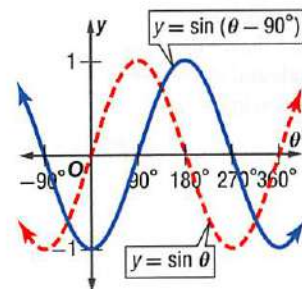

Check Your Progress

- State the amplitude, period, and phase shift for $y = 2 \cos(\theta + 45^\circ)$. Then graph the function.

▶ **Personal Tutor** glencoe.com

Vertical Translations Recall that the graph of $y = x^2 + 5$ is the graph of the parent function $y = x^2$ shifted up 5 units. Similarly, graphs of trigonometric functions can be translated vertically through a **vertical shift**.

StudyTip

Notation Note that $\sin(\theta + x) \neq \sin \theta + x$. The first expression indicates a phase shift. The second expression indicates a vertical shift.



Key Concept

Vertical Shift

For Your
FOLDABLE

Words The vertical shift of the functions $y = a \sin b\theta + k$, $y = a \cos b\theta + k$, and $y = a \tan b\theta + k$ is k .

Models

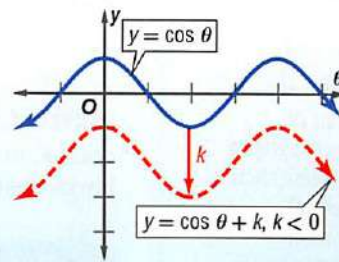
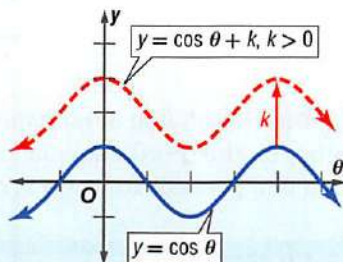

If $k > 0$, the shift is k units up.

If $k < 0$, the shift is k units down.

Examples $y = \sin \theta + 4$ The vertical shift is 4 units up.
 $y = \tan \theta - 3$ The vertical shift is 3 units down.

Math in Motion, Animation glencoe.com

The secant, cosecant, and cotangent can be graphed using the same rules.

When a trigonometric function is shifted up or down k units, the line $y = k$ is the new horizontal axis about which the graph oscillates. This line is called the **midline**, and it can be used to help draw vertical translations.

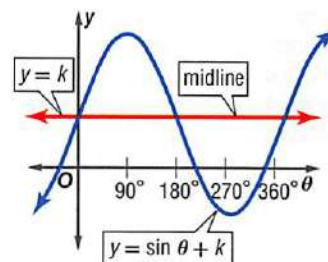

StudyTip

Using Color It may be helpful to first graph the parent function in one color. Next, apply the vertical shift and graph the function in another color. Then apply the change in amplitude and graph the function in the final color.

EXAMPLE 2 Graph Vertical Translations

State the amplitude, period, vertical shift, and equation of the midline for $y = \frac{1}{2} \cos \theta - 2$. Then graph the function.

amplitude: $|a| = \frac{1}{2}$

period: $\frac{2\pi}{|b|} = \frac{2\pi}{|1|}$ or 2π

vertical shift: $k = -2$

midline: $y = -2$

To graph $y = \frac{1}{2} \cos \theta - 2$, first draw the midline. Then use it to graph $y = \frac{1}{2} \cos \theta$ shifted 2 units down.

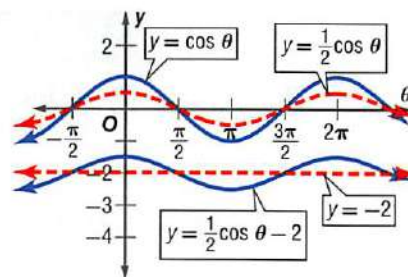

Check Your Progress

2. State the amplitude, period, vertical shift, and equation of the midline for $y = \tan \theta + 3$. Then graph the function.

Personal Tutor glencoe.com

You can use the following steps to graph trigonometric functions involving phase shifts and vertical shifts.

Concept Summary

Graph Trigonometric Functions

For Your
FOLDABLE

$$y = a \sin b(\theta - h) + k$$

amplitude ↓ ↓ period
phase shift ↑ ↑ vertical shift

- Step 1** Determine the vertical shift, and graph the midline.
- Step 2** Determine the amplitude, if it exists. Use dashed lines to indicate the maximum and minimum values of the function.
- Step 3** Determine the period of the function, and graph the appropriate function.
- Step 4** Determine the phase shift, and translate the graph accordingly.

EXAMPLE 3 Graph Transformations

State the amplitude, period, phase shift, and vertical shift for $y = 3 \sin \frac{2}{3}(\theta - \pi) + 4$. Then graph the function.

amplitude: $|a| = 3$

period: $\frac{2\pi}{|b|} = \frac{2\pi}{\frac{2}{3}}$ or 3π

phase shift: $h = \pi$

vertical shift: $k = 4$

midline: $y = 4$

The period indicates that the graph will be stretched.

The graph will shift π to the right.

The graph will shift 4 units up.

The graph will oscillate around the line $y = 4$.

- Step 1** Graph the midline.
- Step 2** Since the amplitude is 3, draw dashed lines 3 units above and 3 units below the midline.
- Step 3** Graph $y = 3 \sin \frac{2}{3}\theta + 4$ using the midline as a reference.
- Step 4** Shift the graph π to the right.

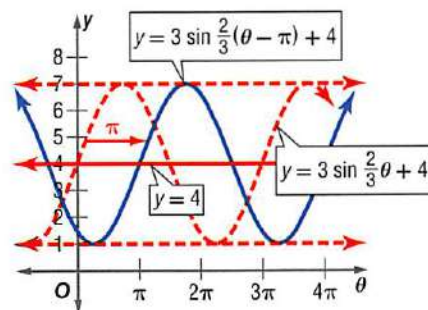

CHECK You can check the accuracy of your transformation by evaluating the function for various values of θ and confirming their location on the graph.

Check Your Progress

3. State the amplitude, period, phase shift, and vertical shift for $y = 2 \cos \frac{1}{2}(\theta + \frac{\pi}{2}) - 2$. Then graph the function.

Personal Tutor glencoe.com

StudyTip

Verifying a Graph

After drawing the graph of a trigonometric function, select values of θ and evaluate them in the equation to verify your graph.



The sine wave occurs often in physics, signal processing, music, electrical engineering, and many other fields.

Real-World EXAMPLE 4 Represent Periodic Functions

WAVE POOL The height of water in a wave pool oscillates between a maximum of 13 feet and a minimum of 5 feet. The wave generator pumps 6 waves per minute. Write a sine function that represents the height of the water at time t seconds. Then graph the function.

Step 1 Write the equation for the midline, and determine the vertical shift.

$$y = \frac{13 + 5}{2} \text{ or } 9$$

The midline lies halfway between the maximum and minimum values.

Since the midline is $y = 9$, the vertical shift is $k = 9$.

Step 2 Find the amplitude.

$$|a| = |13 - 9| \text{ or } 4$$

Find the difference between the midline value and the maximum value.

So, $a = 4$.

Step 3 Find the period.

Since there are 6 waves per minute, there is 1 wave every 10 seconds. So, the period is 10 seconds.

$$10 = \frac{2\pi}{|b|} \quad \text{period} = \frac{2\pi}{|b|}$$

$$|b| = \frac{2\pi}{10} \quad \text{Solve for } |b|.$$

$$b = \pm \frac{\pi}{5} \quad \text{Simplify.}$$

Step 4 Write an equation for the function.

$$h = a \sin b(t - h) + k \quad \text{Write the equation for sine relating height } h \text{ and time } t.$$

$$= 4 \sin \frac{\pi}{5}(t - 0) + 9 \quad \text{Substitution: } a = 4, b = \frac{\pi}{5}, h = 0, k = 9$$

$$= 4 \sin \frac{\pi}{5}t + 9 \quad \text{Simplify.}$$

Then graph the function.

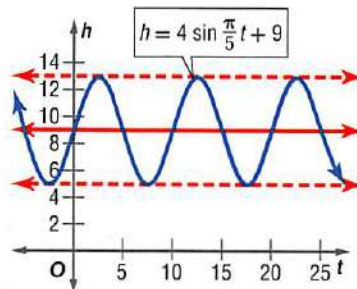

Check Your Progress

4. **WAVE POOL** The height of water in a wave pool oscillates between a maximum of 14 feet and a minimum of 6 feet. The wave generator pumps 5 waves per minute. Write a cosine function that represents the height of water at time t seconds. Then graph the function.

Check Your Understanding

Example 1 p. 863

State the amplitude, period, and phase shift for each function. Then graph the function.

1. $y = \sin(\theta - 180^\circ)$

2. $y = \tan\left(\theta - \frac{\pi}{4}\right)$

3. $y = \sin\left(\theta - \frac{\pi}{2}\right)$

4. $y = \frac{1}{2} \cos(\theta + 90^\circ)$

Example 2 p. 864

State the amplitude, period, vertical shift, and equation of the midline for each function. Then graph the function.

5. $y = \cos \theta + 4$

6. $y = \sin \theta - 2$

7. $y = \frac{1}{2} \tan \theta + 1$

8. $y = \sec \theta - 5$

Example 3 p. 865

State the amplitude, period, phase shift, and vertical shift for each function. Then graph the function.

9. $y = 2 \sin(\theta + 45^\circ) + 1$

10. $y = \cos 3(\theta - \pi) - 4$

11. $y = \frac{1}{4} \tan 2(\theta + 30^\circ) + 3$

12. $y = 4 \sin \frac{1}{2}\left(\theta - \frac{\pi}{2}\right) + 5$

Example 4 p. 866

13. **EXERCISE** While doing some moderate physical activity, a person's blood pressure oscillates between a maximum of 130 and a minimum of 90. The person's heart rate is 90 beats per minute. Write a sine function that represents the person's blood pressure P at time t seconds. Then graph the function.

Practice and Problem Solving

 = **Step-by-Step Solutions** begin on page R20.
Extra Practice begins on page 947.

Example 1 p. 863

State the amplitude, period, and phase shift for each function. Then graph the function.

14. $y = \cos(\theta + 180^\circ)$

15. $y = \tan(\theta - 90^\circ)$

16. $y = \sin(\theta + \pi)$

17. $y = 2 \sin\left(\theta + \frac{\pi}{2}\right)$

18. $y = \tan \frac{1}{2}(\theta + 30^\circ)$

19. $y = 3 \cos\left(\theta - \frac{\pi}{3}\right)$

Example 2 p. 864

State the amplitude, period, vertical shift, and equation of the midline for each function. Then graph the function.

20. $y = \cos \theta + 3$

21. $y = \tan \theta - 1$

22. $y = \tan \theta + \frac{1}{2}$

 23. $y = 2 \cos \theta - 5$

24. $y = 2 \sin \theta - 4$

25. $y = \frac{1}{3} \sin \theta + 7$

Example 3 p. 865

State the amplitude, period, phase shift, and vertical shift for each function. Then graph the function.

26. $y = 4 \sin(\theta - 60^\circ) - 1$

27. $y = \cos \frac{1}{2}(\theta - 90^\circ) + 2$

28. $y = \tan(\theta + 30^\circ) - 2$

29. $y = 2 \tan 2\left(\theta + \frac{\pi}{4}\right) - 5$

30. $y = \frac{1}{2} \sin\left(\theta - \frac{\pi}{2}\right) + 4$

31. $y = \cos 3(\theta - 45^\circ) + \frac{1}{2}$

32. $y = 3 + 5 \sin 2(\theta - \pi)$

33. $y = -2 + 3 \sin \frac{1}{3}\left(\theta - \frac{\pi}{2}\right)$

Example 4 p. 866

34. **TIDES** The height of the water in a harbor rose to a maximum height of 15 feet at 6:00 P.M. and then dropped to a minimum level of 3 feet by 3:00 A.M. The water level can be modeled by the sine function. Write an equation that represents the height h of the water t hours after noon on the first day.

35. **LAKES** A buoy marking the swimming area in a lake oscillates each time a speed boat goes by. Its distance d in feet from the bottom of the lake is given by $d = 1.8 \sin \frac{3\pi}{4}t + 12$, where t is the time in seconds. Graph the function. Describe the minimum and maximum distances of the buoy from the bottom of the lake when a boat passes by.
36. **FERRIS WHEEL** Suppose a Ferris wheel has a diameter of approximately 520 feet and makes one complete revolution in 30 minutes. Suppose the lowest car on the Ferris wheel is 5 feet from the ground. Let the height at the top of the wheel represent the height at time 0. Write an equation for the height of a car h as a function of time t . Then graph the function.

Write an equation for each translation.

37. $y = \sin x$, 4 units to the right and 3 units up
38. $y = \cos x$, 5 units to the left and 2 units down
39. $y = \tan x$, π units to the right and 2.5 units up

40. **JUMP ROPE** The graph at the right approximates the height of a jump rope h in inches as a function of time t in seconds. A maximum point on the graph is $(1.25, 68)$, and a minimum point is $(2.75, 2)$.

- a. Describe what the maximum and minimum points mean in the context of the situation.
- b. What are the equations for the midline, the amplitude, and the period of the function?
- c. Write an equation for the function.

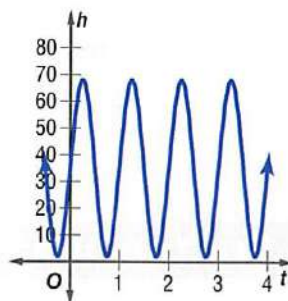

41. **CAROUSEL** A horse on a carousel goes up and down 3 times as the carousel makes one complete rotation. The maximum height of the horse is 55 inches, and the minimum height is 37 inches. The carousel rotates once every 21 seconds. Assume that the horse starts and stops at its median height.

- a. Write an equation to represent the height of the horse h as a function of time t .
- b. Graph the function.
- c. Use your graph to estimate the height of the horse after 8 seconds. Then use a calculator to find the height to the nearest tenth.

42. **TEMPERATURES** During one month, the outside temperature fluctuates between 40°F and 50°F . A cosine curve approximates the change in temperature, with a high of 50°F being reached every four days.

- a. Describe the amplitude, period, and midline of the function that approximates the temperature y on day d .
- b. Write a cosine function to estimate the temperature y on day d .
- c. Sketch a graph of the function.
- d. Estimate the temperature on the 7th day of the month.

Find a coordinate that represents a maximum for each graph.

43. $y = -2 \cos \left(x - \frac{\pi}{2}\right)$

44. $y = 4 \sin \left(x + \frac{\pi}{3}\right)$

45. $y = 3 \tan \left(x + \frac{\pi}{2}\right) + 2$

46. $y = -3 \sin \left(x - \frac{\pi}{4}\right) - 4$

Real-World Link

The record for jump rope is 151,036 jumps of rope in 24 hours. That is an average of 104 skips every minute for the entire day.

Source: Guinness Book of World Records

Compare each pair of graphs.

47. $y = -\cos 3\theta$ and $y = \sin 3(\theta - 90^\circ)$
 48. $y = 2 + 0.5 \tan \theta$ and $y = 2 + 0.5 \tan (\theta + \pi)$
 49. $y = 2 \sin \left(\theta - \frac{\pi}{6}\right)$ and $y = -2 \sin \left(\theta + \frac{5\pi}{6}\right)$

Identify the period of each function. Then write an equation for the graph using the given trigonometric function.

50. sine

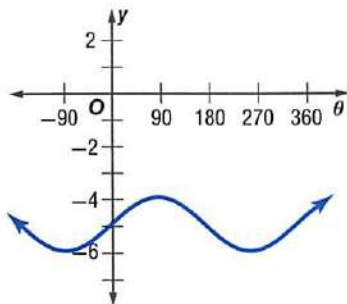

51. cosine

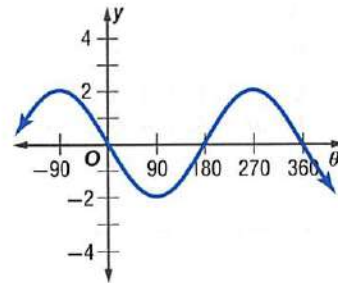

52. cosine

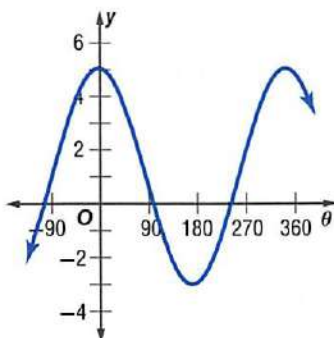

53. sine

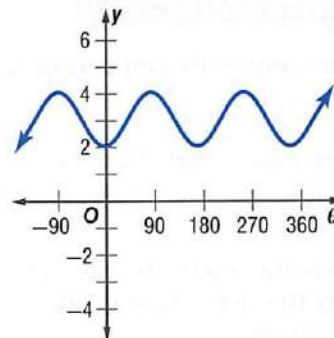

Watch Out!

Parent Functions

Often the graph of a trigonometric function can be represented by more than one equation. For example, the graphs of $y = \cos \theta$ and $y = \sin (\theta + 90^\circ)$ are the same.

State the period, phase shift, and vertical shift. Then graph the function.

54. $y = \csc (\theta + \pi)$
 55. $y = \cot \theta + 6$
 56. $y = \cot \left(\theta - \frac{\pi}{6}\right) - 2$
 57. $y = \frac{1}{2} \csc 3(\theta - 45^\circ) + 1$
 58. $y = 2 \sec \frac{1}{2}(\theta - 90^\circ)$
 59. $y = 4 \sec 2\left(\theta + \frac{\pi}{2}\right) - 3$

H.O.T. Problems

Use Higher-Order Thinking Skills

60. **CHALLENGE** If you are given the amplitude and period of a cosine function, is it *sometimes*, *always*, or *never* possible to find the maximum and minimum values of the function? Explain your reasoning.
61. **REASONING** Describe how the graph of $y = 3 \sin 2\theta + 1$ is different from $y = \sin \theta$.
62. **WRITING IN MATH** Describe two different phase shifts that will translate the sine curve onto the cosine curve shown at the right. Then write an equation for the new sine curve using each phase shift.
63. **OPEN ENDED** Write a periodic function that has an amplitude of 2 and midline at $y = -3$. Then graph the function.
64. **REASONING** How many different sine graphs pass through the origin $(n\pi, 0)$? Explain your reasoning.

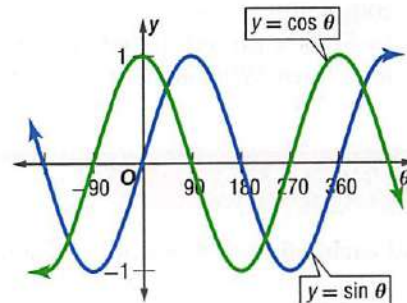

Standardized Test Practice

65. **GRIDDED RESPONSE** The expression $\frac{3x-1}{4} + \frac{x+6}{4}$ is how much greater than x ?

66. Expand $(a - b)^4$.

- A $a^4 - b^4$
- B $a^4 - 4ab + b^4$
- C $a^4 + 4a^3b + 6a^2b^2 + 4ab^3 + b^4$
- D $a^4 - 4a^3b + 6a^2b^2 - 4ab^3 + b^4$

67. Solve $\sqrt{x-3} + \sqrt{x+2} = 5$.

- F 7
- G 0, 7
- H 7, 13
- J no solution

68. **GEOMETRY** Using the figures below, what is the average of a , b , c , d , and f ?

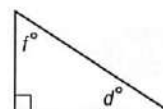
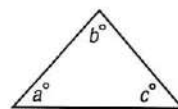

- A 21
- B 45
- C 50
- D 54

Spiral Review

Find the amplitude and period of each function. Then graph the function. (Lesson 13-7)

69. $y = 2 \cos \theta$

70. $y = 3 \sin \theta$

71. $y = \sin 2\theta$

Find the exact value of each expression. (Lesson 13-6)

72. $\sin \frac{4\pi}{3}$

73. $\sin (-30^\circ)$

74. $\cos 405^\circ$

State whether each situation represents an *experiment* or an *observational study*. Identify the *control group* and the *treated group*. Then determine whether there is bias. (Lesson 12-1)

75. Find 220 people and randomly split them into two groups. One group exercises for an hour a day and the other group does not. Then compare their body mass indexes.

76. Find 200 students, half of whom play soccer, and compare the amounts of time spent sleeping.

77. Find 100 students, half of whom have part-time jobs, and compare their grades.

78. **GEOMETRY** Equilateral triangle ABC has a perimeter of 39 centimeters. If the midpoints of the sides are connected, a smaller equilateral triangle results. Suppose the process of connecting midpoints of sides and drawing new triangles is continued indefinitely. (Lesson 11-4)

a. Write an infinite geometric series to represent the sum of the perimeters of all of the triangles.

b. Find the sum of the perimeters of all of the triangles.

79. **CONSTRUCTION** A construction company will be fined for each day it is late completing a bridge. The daily fine will be \$4000 for the first day and will increase by \$1000 each day. Based on its budget, the company can only afford \$60,000 in total fines. What is the maximum number of days it can be late? (Lesson 11-3)

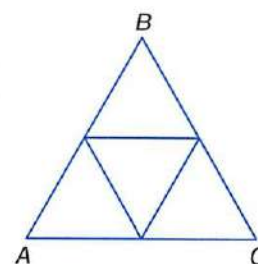

Skills Review

Find each value of θ . Round to the nearest degree. (Lesson 13-1)

80. $\sin \theta = \frac{7}{8}$

81. $\tan \theta = \frac{9}{10}$

82. $\cos \theta = \frac{1}{4}$

83. $\cos \theta = \frac{4}{5}$

84. $\sin \theta = \frac{5}{6}$

85. $\tan \theta = \frac{2}{7}$

Inverse Trigonometric Functions

Then

You graphed trigonometric functions. (Lesson 13-7)

Now

- Find values of inverse trigonometric functions.
- Solve equations by using inverse trigonometric functions.

New Vocabulary

principal values
 Arcsine function
 Arccosine function
 Arctangent function

Math Online

glencoe.com

- Extra Examples
- Personal Tutor
- Self-Check Quiz
- Homework Help
- Math in Motion

Why?

The leaning bookshelf at the right is 15 inches from the wall and reaches a height of 75 inches. In Lesson 13-1, you learned how to use the inverse of a trigonometric function to find the measure of acute angle θ .

$$\tan \theta = \frac{15}{75} \text{ or } 0.2 \quad \text{Use the tangent function.}$$

Find an angle that has a tangent of 0.2.

$$\boxed{2\text{nd}} \boxed{[\text{TAN}^{-1}]} \boxed{.2} \boxed{[\text{ENTER}]} \quad 11.30993247$$

So, the measure of θ is about 11° .



Inverse Trigonometric Functions If you know the value of a trigonometric function for an angle, you can use the *inverse* to find the angle. Recall that an inverse function is the relation in which all values of x and y are reversed. The inverse of $y = \sin x$, $x = \sin y$, is graphed at the right.

Notice that the inverse is not a function because there are many values of y for each value of x . If you restrict the domain of the sine function so that $-\frac{\pi}{2} \leq x \leq \frac{\pi}{2}$, then the inverse is a function.

The values in this restricted domain are called **principal values**. Trigonometric functions with restricted domains are indicated with capital letters.

- $y = \text{Sin } x$ if and only if $y = \sin x$ and $-\frac{\pi}{2} \leq x \leq \frac{\pi}{2}$.
- $y = \text{Cos } x$ if and only if $y = \cos x$ and $0 \leq x \leq \pi$.
- $y = \text{Tan } x$ if and only if $y = \tan x$ and $-\frac{\pi}{2} \leq x \leq \frac{\pi}{2}$.

You can use functions with restricted domains to define inverse trigonometric functions. The inverses of the sine, cosine, and tangent functions are the **Arcsine**, **Arccosine**, and **Arctangent** functions, respectively.

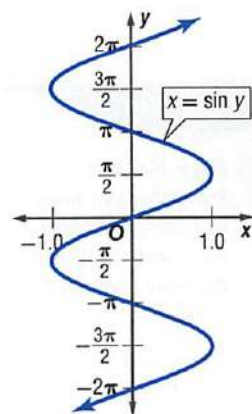

Key Concept

Inverse Trigonometric Functions

For Your **FOLDABLE**

Inverse Function	Symbols	Domain	Range	Model
Arcsine	$y = \text{Arcsin } x$ $y = \text{Sin}^{-1} x$	$-1 \leq x \leq 1$	$-\frac{\pi}{2} \leq y \leq \frac{\pi}{2}$ $-90^\circ \leq y \leq 90^\circ$	
Arccosine	$y = \text{Arccos } x$ $y = \text{Cos}^{-1} x$	$-1 \leq x \leq 1$	$0 \leq y \leq \pi$ $0^\circ \leq y \leq 180^\circ$	
Arctangent	$y = \text{Arctan } x$ $y = \text{Tan}^{-1} x$	all real numbers	$-\frac{\pi}{2} \leq y \leq \frac{\pi}{2}$ $-90^\circ \leq y \leq 90^\circ$	

Math in Motion, Animation glencoe.com

Review Vocabulary

inverse functions If f and f^{-1} are inverse functions, then $f(a) = b$ if and only if $f^{-1}(b) = a$. (Lesson 7-2)

StudyTip

Angle Measure

Remember that when evaluating an inverse trigonometric function, the result is an angle measure.

In the relation $y = \cos^{-1} x$, if $x = \frac{1}{2}$, $y = 60^\circ, 300^\circ$, and all angles that are coterminal with those angles. In the function $y = \text{Cos}^{-1} x$, if $x = \frac{1}{2}$, $y = 60^\circ$ only.

EXAMPLE 1 Evaluate Inverse Trigonometric Functions

Find each value. Write angle measures in degrees and radians.

a. $\text{Cos}^{-1}\left(-\frac{1}{2}\right)$

Find the angle θ for $0^\circ \leq \theta \leq 180^\circ$ that has a cosine value of $-\frac{1}{2}$.

Method 1 Use a unit circle.

Find a point on the unit circle that has an x -coordinate of $-\frac{1}{2}$.

When $\theta = 120^\circ$, $\cos \theta = -\frac{1}{2}$.

So, $\text{Cos}^{-1}\left(-\frac{1}{2}\right) = 120^\circ$ or $\frac{2\pi}{3}$.

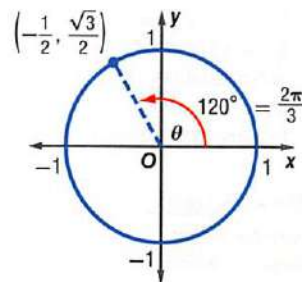

Method 2 Use a calculator.

KEYSTROKES: $\boxed{2\text{nd}}$ $\boxed{[\text{COS}^{-1}]}$ $\boxed{(-)}$ $\boxed{1}$ $\boxed{\div}$ $\boxed{2}$ $\boxed{)}$ $\boxed{\text{ENTER}}$ 120

Therefore, $\text{Cos}^{-1}\left(-\frac{1}{2}\right) = 120^\circ$ or $\frac{2\pi}{3}$.

b. **Arctan 1**

Find the angle θ for $-90^\circ \leq \theta \leq 90^\circ$ that has a tangent value of 1.

KEYSTROKES: $\boxed{2\text{nd}}$ $\boxed{[\text{TAN}^{-1}]}$ $\boxed{1}$ $\boxed{\text{ENTER}}$ 45 Therefore, $\text{Arctan } 1 = 45^\circ$ or $\frac{\pi}{4}$.

Check Your Progress

1A. $\text{Cos}^{-1} 0$

1B. $\text{Arcsin}\left(-\frac{\sqrt{2}}{2}\right)$

glencoe.com

When finding a value when there are multiple trigonometric functions involved, use the order of operations to solve.

EXAMPLE 2 Find a Trigonometric Value

Find $\tan\left(\text{Cos}^{-1}\frac{1}{2}\right)$. Round to the nearest hundredth.

Use a calculator.

KEYSTROKES: $\boxed{[\text{TAN}]}$ $\boxed{2\text{nd}}$ $\boxed{[\text{COS}^{-1}]}$ $\boxed{1}$ $\boxed{\div}$ $\boxed{2}$ $\boxed{)}$ $\boxed{\text{ENTER}}$ 1.732050808

So, $\tan\left(\text{Cos}^{-1}\frac{1}{2}\right) \approx 1.73$.

CHECK $\text{Cos}^{-1}\frac{1}{2} = 60^\circ$ and $\tan 60^\circ \approx 1.73$. So, the answer is correct.

Check Your Progress

Find each value. Round to the nearest hundredth.

2A. $\sin\left(\text{Tan}^{-1}\frac{3}{8}\right)$

2B. $\cos\left(\text{Arccos}-\frac{\sqrt{2}}{2}\right)$

glencoe.com

Solve Equations by Using Inverses You can rewrite trigonometric equations to solve for the measure of an angle.

Test-Taking Tip

Eliminate Possibilities
Because $\sin \theta$ is negative, look for angle measures in Quadrants III and IV.

STANDARDIZED TEST EXAMPLE 3

If $\sin \theta = -0.35$, find θ .

- A -20.5° B -0.6° C 0.6° D 20.5°

Read the Test Item

The sine of angle θ is -0.35 . This can be written as $\text{Arcsin}(-0.35) = \theta$.

Solve the Test Item

Use a calculator.

KEYSTROKES: $\boxed{2\text{nd}} \boxed{[\text{SIN}^{-1}]} \boxed{(-)} .35 \boxed{\text{ENTER}}$ -20.48731511

So, $\theta \approx -20.5^\circ$. The answer is A.

Check Your Progress

3. If $\tan \theta = 1.8$, find θ .

- F 0.03° G 29.1° H 60.9° J no solution

Personal Tutor glencoe.com

Inverse trigonometric functions can be used to determine angles of inclination, depression, and elevation.

Real-World EXAMPLE 4 Use Inverse Trigonometric Functions

WATER SKIING A water ski ramp is 6 feet tall and 9 feet long, as shown at the right. Write an inverse trigonometric function that can be used to find θ , the angle the ramp makes with the water. Then find the measure of the angle. Round to the nearest tenth.

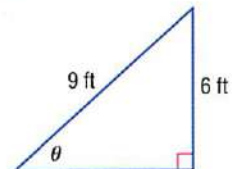

Because the measures of the opposite side and the hypotenuse are known, you can use the sine function.

$$\sin \theta = \frac{6}{9} \quad \text{Sine function}$$

$$\theta = \text{Sin}^{-1} \frac{6}{9} \quad \text{Inverse sine function}$$

$$\theta \approx 41.8^\circ \quad \text{Use a calculator.}$$

So, the angle of the ramp is about 41.8° .

CHECK Using your calculator, $\sin 41.8 \approx 0.66653 \approx \frac{6}{9}$.
So, the answer is correct.

Check Your Progress

4. **SKIING** A ski trail is shown at the right. Write an inverse trigonometric function that can be used to find θ , the angle the trail makes with the ground in the valley. Then find the angle. Round to the nearest tenth.

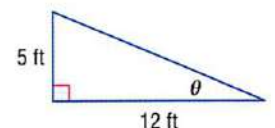

Personal Tutor glencoe.com

Check Your Understanding

Example 1
p. 872

Find each value. Write angle measures in degrees and radians.

1. $\sin^{-1} \frac{1}{2}$ 2. $\text{Arctan}(-\sqrt{3})$ 3. $\text{Arccos}(-1)$

Example 2
p. 872

Find each value. Round to the nearest hundredth if necessary.

4. $\cos\left(\text{Arcsin} \frac{4}{5}\right)$ 5. $\tan(\text{Cos}^{-1} 1)$ 6. $\sin\left(\text{Sin}^{-1} \frac{\sqrt{3}}{2}\right)$

Example 3
p. 873

7. **MULTIPLE CHOICE** If $\sin \theta = 0.422$, find θ .

- A 25° B 42° C 48° D 65°

Solve each equation. Round to the nearest tenth if necessary.

8. $\cos \theta = 0.9$ 9. $\sin \theta = -0.46$ 10. $\tan \theta = 2.1$

Example 4
p. 873

11. **SNOWBOARDING** A cross section of a superpipe for snowboarders is shown at the right. Write an inverse trigonometric function that can be used to find θ , the angle that describes the steepness of the superpipe. Then find the angle to the nearest degree.

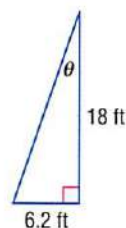

Practice and Problem Solving

= **Step-by-Step Solutions** begin on page R20.
Extra Practice begins on page 947.

Example 1
p. 872

Find each value. Write angle measures in degrees and radians.

12. $\text{Arcsin}\left(\frac{\sqrt{3}}{2}\right)$ 13. $\text{Arccos}\left(\frac{\sqrt{3}}{2}\right)$ 14. $\text{Sin}^{-1}(-1)$
15. $\text{Tan}^{-1} \sqrt{3}$ 16. $\text{Cos}^{-1}\left(-\frac{\sqrt{3}}{2}\right)$ 17. $\text{Arctan}\left(-\frac{\sqrt{3}}{3}\right)$

Example 2
p. 872

Find each value. Round to the nearest hundredth if necessary.

18. $\tan(\text{Cos}^{-1} 1)$ 19. $\tan\left[\text{Arcsin}\left(-\frac{1}{2}\right)\right]$ 20. $\cos\left(\text{Tan}^{-1} \frac{3}{5}\right)$
21. $\sin(\text{Arctan} \sqrt{3})$ 22. $\cos\left(\text{Sin}^{-1} \frac{4}{9}\right)$ 23. $\sin\left[\text{Cos}^{-1}\left(-\frac{\sqrt{2}}{2}\right)\right]$

Example 3
p. 873

Solve each equation. Round to the nearest tenth if necessary.

24. $\tan \theta = 3.8$ 25. $\sin \theta = 0.9$ 26. $\sin \theta = -2.5$
27. $\cos \theta = -0.25$ 28. $\cos \theta = 0.56$ 29. $\tan \theta = -0.2$

Example 4
p. 873

30. **BOATS** A boat is traveling west to cross a river that is 190 meters wide. Because of the current, the boat lands at point Q , which is 59 meters from its original destination point P . Write an inverse trigonometric function that can be used to find θ , the angle at which the boat veered south of the horizontal line. Then find the measure of the angle to the nearest tenth.

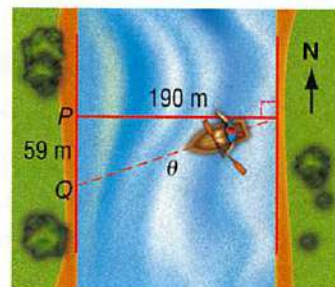

31. **TREES** A 24-foot tree is leaning 2.5 feet left of vertical, as shown in the figure. Write an inverse trigonometric function that can be used to find θ , the angle at which the tree is leaning. Then find the measure of the angle to the nearest degree.

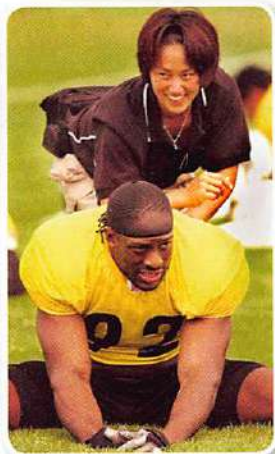
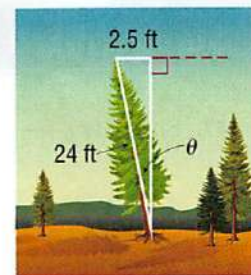

Real-World Career

Sport Science Administrator

A sport science administrator provides sport science information to players, coaches, and parents. He or she implements testing, training, and treatment programs for athletes. A master's degree in sport science or a related area is recommended.

32. **DRIVING** An expressway off-ramp curve has a radius of 52 meters and is designed for vehicles to safely travel at speeds up to 45 kilometers per hour (or 12.5 meters per second). The equation below represents the angle θ of the curve. What is the measure of the angle to the nearest degree?

$$\tan \theta = \frac{(12.5 \text{ m/s})^2}{(52 \text{ m})(9.8 \text{ m/s}^2)}$$

33. **TRACK AND FIELD** A shot-putter throws the shot with an initial speed of 15 meters per second. The expression $\frac{15 \text{ m/s} (\sin x)}{9.8 \text{ m/s}^2}$ represents the time in seconds at which the shot reached its maximum height. In the expression, x is the angle at which the shot was thrown. If the maximum height of the shot was reached in 1.0 second, at what angle was it thrown? Round to the nearest tenth.

Solve each equation for $0 \leq \theta \leq 2\pi$.

34. $\csc \theta = 1$

35. $\sec \theta = -1$

36. $\sec \theta = 1$

37. $\csc \theta = \frac{1}{2}$

38. $\cot \theta = 1$

39. $\sec \theta = 2$

40. **MULTIPLE REPRESENTATIONS** Consider $y = \cos^{-1} x$.

- GRAPHICAL** Sketch a graph of the function. Describe the domain and the range.
- SYMBOLIC** Write the function using different notation.
- NUMERICAL** Choose a value for x between -1 and 0 . Then evaluate the inverse cosine function. Round to the nearest tenth.
- ANALYTICAL** Compare the graphs of $y = \cos x$ and $y = \cos^{-1} x$.

H.O.T. Problems

Use **H**igher-**O**rders **T**hinking Skills

41. **CHALLENGE** Determine whether $\cos(\text{Arccos } x) = x$ for all values of x is true or false. If false, give a counterexample.
42. **FIND THE ERROR** Desiree and Oscar are solving $\cos \theta = 0.3$ where $90 < \theta < 180$. Is either of them correct? Explain your reasoning.

Desiree

$$\cos \theta = 0.3$$

$$\cos^{-1} 0.3 = 162.5^\circ$$

Oscar

$$\cos \theta = 0.3$$

$$\cos^{-1} 0.3 = 72.5^\circ$$

43. **REASONING** Explain how the domain of $y = \sin^{-1} x$ is related to the range of $y = \sin x$.
44. **OPEN ENDED** Write an equation with an Arcsine function and an equation with a Sine function that both involve the same angle measure.
45. **WRITING IN MATH** Compare and contrast the relations $y = \tan^{-1} x$ and $y = \text{Tan}^{-1} x$. Include information about the domains and ranges.
46. **REASONING** Explain how $\sin^{-1} 8$ and $\cos^{-1} 8$ are undefined while $\text{Tan}^{-1} 8$ is defined.

Standardized Test Practice

47. Simplify $\frac{\frac{2}{x} + 2}{\frac{2}{x} - 2}$.

A $\frac{1+x}{1-x}$

C $\frac{1-x}{1+x}$

B $\frac{2}{x}$

D $-x$

48. **SHORT RESPONSE** What is the equation of the graph below?

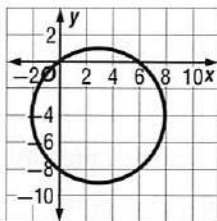

49. If $f(x) = 2x^2 - 3x$ and $g(x) = 4 - 2x$, what is $g[f(x)]$?

F $g[f(x)] = 4 + 6x - 8x^2$

G $g[f(x)] = 4 + 6x - 4x^2$

H $g[f(x)] = 20 - 26x + 8x^2$

J $g[f(x)] = 44 - 38x + 8x^2$

50. If g is a positive number, which of the following is equal to $12g$?

A $\sqrt{144g}$

B $\sqrt{12g^2}$

C $\sqrt{24g^2}$

D $6\sqrt{4g^2}$

Spiral Review

51. **RIDES** The Cosmoclock 21 is a huge Ferris wheel in Japan. The diameter is 328 feet. Suppose a rider enters the ride at 0 feet, and then rotates in 90° increments counterclockwise. The table shows the angle measures of rotation and the height above the ground of the rider. (Lesson 13-8)

- a. A function that models the data is $y = 164 \cdot [\sin(x - 90^\circ)] + 164$. Identify the vertical shift, amplitude, period, and phase shift of the graph.
- b. Write an equation using the sine that models the position of a rider on the Vienna Giant Ferris Wheel in Austria, with a diameter of 200 feet. Check your equation by plotting the points and the equation with a graphing calculator.

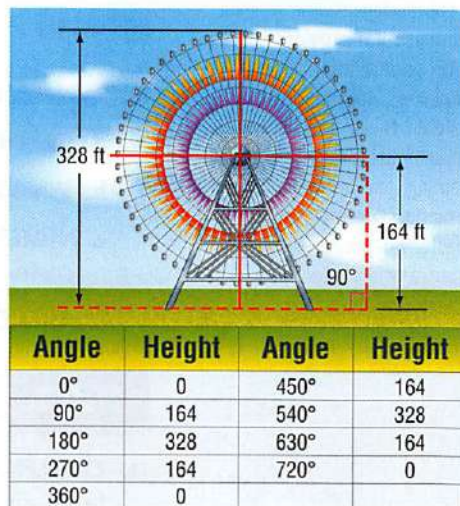

52. **TIDES** The world's record for the highest tide is held by the Minas Basin in Nova Scotia, Canada, with a tidal range of 54.6 feet. A tide is at equilibrium when it is at its normal level halfway between its highest and lowest points. Write an equation to represent the height h of the tide. Assume that the tide is at equilibrium at $t = 0$, that the high tide is beginning, and that the tide completes one cycle in 12 hours. (Lesson 13-7)

Solve each equation. (Lesson 8-4)

53. $\log_3 5 + \log_3 x = \log_3 10$

54. $\log_4 a + \log_4 9 = \log_4 27$

55. $\log_{10} 16 - \log_{10} 2t = \log_{10} 2$

56. $\log_7 24 - \log_7 (y + 5) = \log_3 8$

Skills Review

Find the exact value of each trigonometric function. (Lesson 13-3)

57. $\cos 3\pi$

58. $\tan 120^\circ$

59. $\sin 300^\circ$

60. $\sec \frac{7\pi}{6}$

Chapter Summary

Key Concepts

Right Triangle Trigonometry (Lesson 13-1)

$$\begin{aligned} \sin \theta &= \frac{\text{opp}}{\text{hyp}}, \cos \theta = \frac{\text{adj}}{\text{hyp}}, \tan \theta = \frac{\text{opp}}{\text{adj}}, \\ \csc \theta &= \frac{\text{hyp}}{\text{opp}}, \sec \theta = \frac{\text{hyp}}{\text{adj}}, \cot \theta = \frac{\text{adj}}{\text{opp}} \end{aligned}$$

Angle Measures and Trigonometric Functions of General Angles (Lessons 13-2 and 13-3)

- The measure of an angle is determined by the amount of rotation from the initial side to the terminal side.
- You can find the exact values of the six trigonometric functions of θ , given the coordinates of a point $P(x, y)$ on the terminal side of the angle.

Law of Sines and Law of Cosines

(Lessons 13-4 and 13-5)

$$\begin{aligned} \frac{\sin A}{a} &= \frac{\sin B}{b} = \frac{\sin C}{c} \\ a^2 &= b^2 + c^2 - 2bc \cos A \\ b^2 &= a^2 + c^2 - 2ac \cos B \\ c^2 &= a^2 + b^2 - 2ab \cos C \end{aligned}$$

Circular and Inverse Trigonometric Functions

(Lessons 13-6 and 13-9)

- If the terminal side of an angle θ in standard position intersects the unit circle at $P(x, y)$, then $\cos \theta = x$ and $\sin \theta = y$.
- $y = \sin x$ if $y = \sin x$ and $-\frac{\pi}{2} \leq x \leq \frac{\pi}{2}$

Graphing Trigonometric Functions (Lesson 13-7)

- For trigonometric functions of the form $y = a \sin b\theta$ and $y = a \cos b\theta$, the amplitude is $|a|$, and the period is $\frac{360^\circ}{|b|}$ or $\frac{2\pi}{|b|}$.
- The period of $y = a \tan b\theta$ is $\frac{180^\circ}{|b|}$ or $\frac{\pi}{|b|}$.

FOLDABLES® Study Organizer

Be sure the Key Concepts are noted in your Foldable.

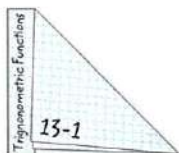

Key Vocabulary

amplitude (p. 855)	period (p. 849)
angle of depression (p. 812)	periodic function (p. 849)
angle of elevation (p. 812)	phase shift (p. 863)
Arccosine function (p. 871)	principle values (p. 871)
Arcsine function (p. 871)	quadrantal angle (p. 826)
Arctangent function (p. 871)	radian (p. 819)
central angle (p. 820)	reference angle (p. 826)
circular function (p. 848)	secant (p. 808)
cosecant (p. 808)	sine (p. 808)
cosine (p. 808)	solving a triangle (p. 833)
cotangent (p. 808)	standard position (p. 817)
coterminal angles (p. 818)	tangent (p. 808)
cycle (p. 849)	terminal side (p. 817)
frequency (p. 856)	trigonometric function (p. 808)
initial side (p. 817)	trigonometric ratio (p. 808)
Law of Cosines (p. 841)	trigonometry (p. 808)
Law of Sines (p. 833)	unit circle (p. 848)
midline (p. 864)	vertical shift (p. 864)

Vocabulary Check

State whether each sentence is *true* or *false*. If *false*, replace the underlined term to make a true sentence.

1. The Law of Cosines is used to solve a triangle when two angles and any sides are known.
2. An angle on the coordinate plane is in standard position if the vertex is at the origin and one ray is on the positive x-axis.
3. Coterminal angles are angles in standard position that have the same terminal side.
4. A horizontal translation of a periodic function is called a phase shift.
5. The inverse of the sine function is the cosecant function.
6. The cycle of the graph of a sine or cosine function equals half the difference between the maximum and minimum values of the function.

Lesson-by-Lesson Review

13-1 Right Triangle Trigonometry (pp. 808–816)

Solve $\triangle ABC$ by using the given measurements. Round measures of sides to the nearest tenth and measures of angles to the nearest degree.

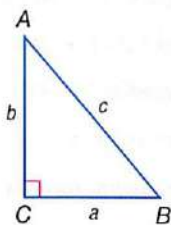

7. $c = 12, b = 5$
8. $a = 10, B = 55^\circ$
9. $B = 75^\circ, b = 15$
10. $B = 45^\circ, c = 16$
11. $A = 35^\circ, c = 22$
12. $\sin A = \frac{2}{3}, a = 6$
13. **TRUCK** The back of a moving truck is 3 feet off of the ground. What length does a ramp off the back of the truck need to be in order for the angle of elevation of the ramp to be 20° ?

EXAMPLE 1

Solve $\triangle ABC$ by using the given measurements. Round measures of sides to the nearest tenth and measures of angles to the nearest degree.

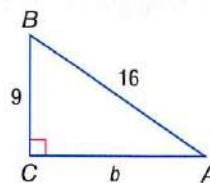

$$\begin{aligned} \text{Find } b. \quad a^2 + b^2 &= c^2 \\ 9^2 + b^2 &= 16^2 \\ b &= \sqrt{16^2 - 9^2} \\ b &\approx 13.2 \end{aligned}$$

$$\begin{aligned} \text{Find } A. \quad \sin A &= \frac{9}{16} \\ \text{Use a calculator.} \\ \text{To the nearest degree, } A &= 34^\circ. \end{aligned}$$

$$\begin{aligned} \text{Find } B. \quad 34^\circ + B &\approx 90^\circ \\ B &\approx 56^\circ \end{aligned}$$

Therefore, $b \approx 13.2$, $A \approx 34^\circ$, and $B \approx 56^\circ$.

13-2 Angles and Angle Measures (pp. 817–823)

Rewrite each degree measure in radians and each radian measure in degrees.

14. 215°
15. $\frac{5\pi}{2}$
16. -3π
17. -315°

Find one angle with positive measure and one angle with negative measure coterminal with each angle.

18. 265°
19. -65°
20. $\frac{7\pi}{2}$

21. **BICYCLE** A bicycle tire makes 8 revolutions in one minute. The tire has a radius of 15 inches. Find the angle θ in radians through which the tire rotates in one second.



EXAMPLE 2

Rewrite 160° in radians.

$$\begin{aligned} 160^\circ &= 160^\circ \left(\frac{\pi \text{ radians}}{180^\circ} \right) \\ &= \frac{160\pi}{180} \text{ radians or } \frac{8\pi}{9} \end{aligned}$$

EXAMPLE 3

Find one angle with positive measure and one angle with negative measure coterminal with 150° .

positive angle:

$$150^\circ + 360^\circ = 510^\circ \quad \text{Add } 360^\circ.$$

negative angle:

$$150^\circ - 360^\circ = -210^\circ \quad \text{Subtract } 360^\circ.$$

13-3 Trigonometric Functions of General Angles (pp. 825–831)

Find the exact value of each trigonometric function.

22. $\cos 135^\circ$ 23. $\tan 150^\circ$
 24. $\sin 2\pi$ 25. $\cos \frac{3\pi}{2}$

The terminal side of θ in standard position contains each point. Find the exact values of the six trigonometric functions of θ .

26. $P(-4, 3)$
 27. $P(5, 12)$
 28. $P(16, -12)$

29. **BALL** A ball is thrown off the edge of a building at an angle of 70° and with an initial velocity of 5 meters per second. The equation that represents the horizontal distance of the ball x is $x = v_0(\cos \theta)t$, where v_0 is the initial velocity, θ is the angle at which it is thrown, and t is the time in seconds. About how far will the ball travel in 10 seconds?

EXAMPLE 4

Find the exact value of $\sin 120^\circ$.

Because the terminal side of 120° lies in Quadrant II, the reference angle θ' is $180^\circ - 120^\circ$ or 60° .

The sine function is positive in Quadrant II, so $\sin 120^\circ = \sin 60^\circ$ or $\frac{\sqrt{3}}{2}$.

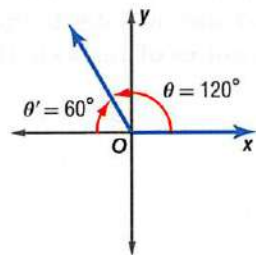

EXAMPLE 5

The terminal side of θ in standard position contains the point $(6, 5)$. Find the exact values of the six trigonometric functions of θ .

$$\begin{array}{lll} \sin \theta = \frac{y}{r} \text{ or } \frac{5\sqrt{61}}{61} & \cos \theta = \frac{x}{r} \text{ or } \frac{6\sqrt{61}}{61} & \tan \theta = \frac{y}{x} \text{ or } \frac{5}{6} \\ \csc \theta = \frac{r}{y} \text{ or } \frac{\sqrt{61}}{5} & \sec \theta = \frac{r}{x} \text{ or } \frac{\sqrt{61}}{6} & \cot \theta = \frac{x}{y} \text{ or } \frac{6}{5} \end{array}$$

13-4 Law of Sines (pp. 832–839)

Determine whether each triangle has *no* solution, *one* solution, or *two* solutions. Then solve each triangle. Round measures of sides to the nearest tenth and measures of angles to the nearest degree.

30. $C = 118^\circ, c = 10, a = 4$
 31. $A = 25^\circ, a = 15, c = 18$
 32. $A = 70^\circ, a = 5, c = 16$
 33. **BOAT** Kira and Mallory are standing on opposite sides of a river. How far is Kira from the boat? Round to the nearest tenth if necessary.

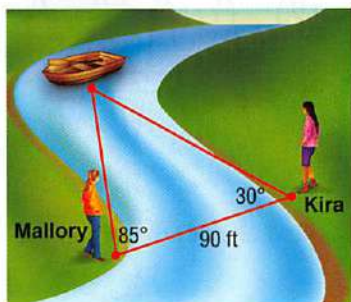

EXAMPLE 6

Solve $\triangle ABC$.

First, find the measure of the third angle.

$$\begin{aligned} 60^\circ + 70^\circ + A &= 180^\circ \\ A &= 50^\circ \end{aligned}$$

Now use the Law of Sines to find a and c . Write two equations, each with one variable.

$$\begin{array}{ll} \frac{\sin B}{b} = \frac{\sin C}{c} & \frac{\sin B}{b} = \frac{\sin A}{a} \\ \frac{\sin 60^\circ}{8} = \frac{\sin 70^\circ}{c} & \frac{\sin 60^\circ}{8} = \frac{\sin 50^\circ}{a} \\ c = \frac{8 \sin 70^\circ}{\sin 60^\circ} & a = \frac{8 \sin 50^\circ}{\sin 60^\circ} \\ c \approx 8.9 & a \approx 7.1 \end{array}$$

Therefore, $A = 50^\circ, c \approx 8.9$, and $a \approx 7.1$.

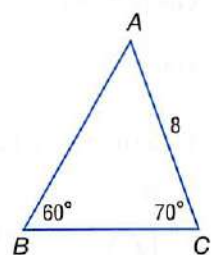

13-5 Law of Cosines (pp. 841–846)

Determine whether each triangle should be solved by beginning with the Law of Sines or Law of Cosines. Then solve each triangle. Round measures of sides to the nearest tenth and measures of angles to the nearest degree.

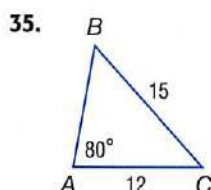
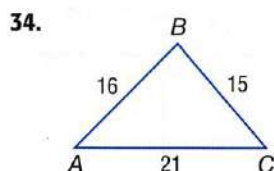

36. $C = 75^\circ$, $a = 5$, $b = 7$

37. $A = 42^\circ$, $a = 9$, $b = 13$

38. $b = 8.2$, $c = 15.4$, $A = 35^\circ$

39. **FARMING** A farmer wants to fence a piece of his land. Two sides of the triangular field have lengths of 120 feet and 325 feet. The measure of the angle between those sides is 70° . How much fencing will the farmer need?

EXAMPLE 7

Solve $\triangle ABC$ for $C = 55^\circ$, $b = 11$, and $a = 8$.

You are given the measure of two sides and the included angle. Begin by drawing a diagram and using the Law of Cosines to determine c .

$$c^2 = a^2 + b^2 - 2ab \cos C$$

$$c^2 = 8^2 + 11^2 - 2(8)(11) \cos 55^\circ$$

$$c^2 \approx 84$$

$$c \approx 9.2$$

Next, you can use the Law of Sines to find the measure of angle A .

$$\frac{\sin A}{8} \approx \frac{\sin 55^\circ}{9.2}$$

$$\sin A \approx \frac{8 \sin 55^\circ}{9.2} \text{ or } A \text{ is about } 45.4^\circ$$

The measure of the angle B is approximately $180 - (45.4 + 55)$ or 79.6° .

Therefore, $c \approx 9.2$, $A \approx 45.4^\circ$, and $B \approx 79.6^\circ$.

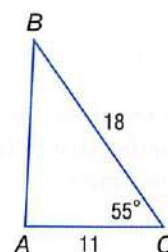
**13-6** Circular Functions (pp. 848–854)

Find the exact value of each function.

40. $\cos(-210^\circ)$ 41. $(\cos 45^\circ)(\cos 210^\circ)$

42. $\sin \frac{7\pi}{4}$ 43. $\left(\cos \frac{\pi}{2}\right)\left(\sin \frac{\pi}{2}\right)$

44. Determine the period of the function.

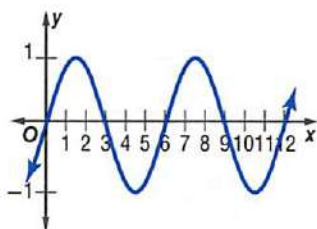

45. A wheel with a diameter of 18 inches completes 4 revolutions in 1 minute. What is the period of the function that describes the height of one spot on the outside edge of the wheel as a function of time?

EXAMPLE 8

Find the exact value of $\sin 510^\circ$.

$$\sin 510^\circ = \sin(310^\circ + 150^\circ)$$

$$= \sin 150^\circ$$

$$= \frac{1}{2}$$

EXAMPLE 9

Determine the period of the function below.

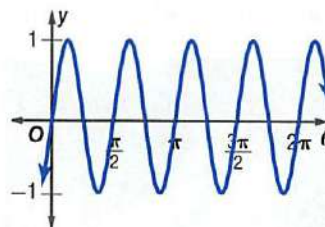

The pattern repeats itself at $\frac{\pi}{2}$, π , and so on. So, the period is $\frac{\pi}{2}$.

13-7 Graphing Trigonometric Functions (pp. 855–861)

Find the amplitude, if it exists, and period of each function. Then graph the function.

46. $y = 4 \sin 2\theta$
47. $y = \cos \frac{1}{2}\theta$
48. $y = 3 \csc \theta$
49. $y = 3 \sec \theta$
50. $y = \tan 2\theta$
51. $y = 2 \csc \frac{1}{2}\theta$
52. When Lauren jumps on a trampoline it vibrates with a frequency of 10 hertz. Let the amplitude equal 5 feet. Write a sine equation to represent the vibration of the trampoline y as a function of time t .

EXAMPLE 10

Find the amplitude and period of $y = 2 \cos 4\theta$. Then graph the function.

amplitude: $|a| = |2|$ or 2. The graph is stretched vertically so that the maximum value is 2 and the minimum value is -2 .

period:
 $\frac{360^\circ}{|b|} = \frac{360^\circ}{|4|}$ or 90°

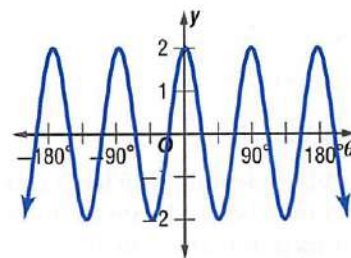

13-8 Translations of Trigonometric Graphs (pp. 863–870)

State the vertical shift, amplitude, period, and phase shift of each function. Then graph the function.

53. $y = 3 \sin [2(\theta - 90^\circ)] + 1$
54. $y = \frac{1}{2} \tan [2(\theta - 30^\circ)] - 3$
55. $y = 2 \sec \left[3\left(\theta - \frac{\pi}{2}\right) \right] + 2$
56. $y = \frac{1}{2} \cos \left[\frac{1}{4}\left(\theta + \frac{\pi}{4}\right) \right] - 1$
57. $y = \frac{1}{3} \sin \left[\frac{1}{3}(\theta - 90^\circ) \right] + 2$
58. The graph below approximates the height y of a rope that two people are twirling as a function of time t in seconds. Write an equation for the function.

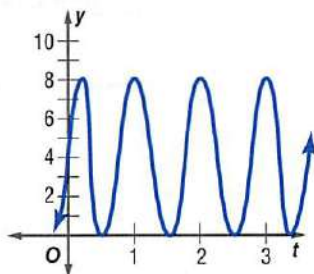

EXAMPLE 11

State the vertical shift, amplitude, period, and phase shift of $y = 2 \sin \left[3\left(\theta + \frac{\pi}{2}\right) \right] + 4$. Then graph the function.

Identify the values of k , a , b , and h .

$k = 4$, so the vertical shift is 4.

$a = 2$, so the amplitude is 2.

$b = 3$, so the period is $\frac{2\pi}{|3|}$ or $\frac{2\pi}{3}$.

$h = -\frac{\pi}{2}$, so the phase shift is $\frac{\pi}{2}$ to the left.

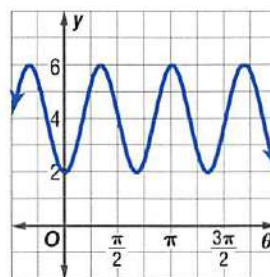

13-9 Inverse Trigonometric Functions (pp. 871–876)

Evaluate each inverse trigonometric function. Write angle measures in degrees and radians.

59. $\sin^{-1}(1)$
 60. $\arctan(0)$
 61. $\arcsin \frac{\sqrt{3}}{2}$
 62. $\cos^{-1} \frac{\sqrt{2}}{2}$
 63. $\tan^{-1} 1$
 64. $\arccos 0$
 65. A bicycle ramp is 5 feet tall and 10 feet long, as shown below. Write an inverse trigonometric function that can be used to find θ , the angle the ramp makes with the ground. Then find the angle. Round to the nearest hundredth.

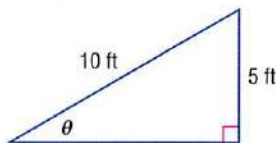

Evaluate each inverse trigonometric function. Round to the nearest hundredth if necessary.

66. $\tan \left(\cos^{-1} \frac{1}{3} \right)$
 67. $\sin \left(\arcsin -\frac{\sqrt{2}}{2} \right)$
 68. $\sin (\tan^{-1} 0)$

Solve each equation. Round to the nearest tenth if necessary.

69. $\tan \theta = -1.43$
 70. $\sin \theta = 0.8$
 71. $\cos \theta = 0.41$

EXAMPLE 12

Evaluate $\cos^{-1} \frac{1}{2}$. Write angle measures in degrees and radians.

Find the angle θ for $0^\circ \leq \theta \leq 180^\circ$ that has a cosine value of $\frac{1}{2}$.

Use a unit circle.

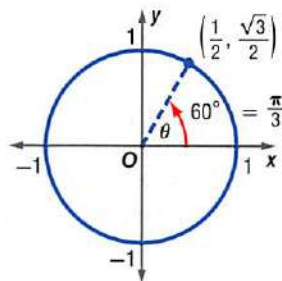

Find a point on the unit circle that has an x -coordinate of $\frac{1}{2}$. When $\theta = 60^\circ$, $\cos \theta = \frac{1}{2}$. So, $\cos^{-1} = 60^\circ$ or $\frac{\pi}{3}$.

EXAMPLE 13

Evaluate $\sin \left(\tan^{-1} \frac{1}{2} \right)$. Round to the nearest hundredth.

Use a calculator.

KEYSTROKES: **SIN** **2nd** **[TAN⁻¹]** **1** **÷** **2** **)** **ENTER**

0.4472135955

So, $\sin \left(\tan^{-1} \frac{1}{2} \right) \approx 0.45$.

EXAMPLE 14

If $\cos \theta = 0.72$, find θ .

Use a calculator.

KEYSTROKES: **2nd** **[COS⁻¹]** **.72** **ENTER** 43.9455195623

So, $\theta \approx 43.9^\circ$.

Solve $\triangle ABC$ by using the given measurements. Round measures of sides to the nearest tenth and measures of angles to the nearest degree.

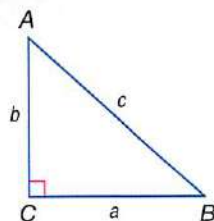

- $A = 36^\circ, c = 9$
- $a = 12, A = 58^\circ$
- $B = 85^\circ, b = 8$
- $a = 9, c = 12$

Rewrite each degree measure in radians and each radian measure in degrees.

- 325°
- $-\frac{9\pi}{4}$
- Determine whether $\triangle ABC$, with $A = 110^\circ, a = 16$, and $b = 21$, has *no* solution, *one* solution, or *two* solutions. Then solve the triangle, if possible. Round measures of sides to the nearest tenth and measures of angles to the nearest degree.

Find the exact value of each function. Write angle measures in degrees.

- $\cos(-90^\circ)$
- $\cot \frac{4\pi}{3}$
- $\tan(\cos^{-1} \frac{4}{5})$
- The terminal side of angle θ in standard position intersects the unit circle at point $P(\frac{1}{2}, \frac{\sqrt{3}}{2})$. Find $\cos \theta$ and $\sin \theta$.
- MULTIPLE CHOICE** What angle has a tangent and sine that are both negative?
 - 65°
 - 310°
 - 120°
 - 265°

- NAVIGATION** Airplanes and ships measure distance in nautical miles. The formula $1 \text{ nautical mile} = 6077 - 31 \cos 2\theta$ feet, where θ is the latitude in degrees, can be used to find the approximate length of a nautical mile at a certain latitude. Find the length of a nautical mile when the latitude is 120° .

Find the amplitude and period of each function. Then graph the function.

- $y = 2 \sin 3\theta$
- $y = \frac{1}{2} \cos 2\theta$
- MULTIPLE CHOICE** What is the period of the function $y = 3 \cot \theta$?
 - 120°
 - 180°
 - 360°
 - 1080°
- Determine whether $\triangle XYZ$, with $y = 15, z = 9$, and $X = 105^\circ$, should be solved by beginning with the Law of Sines or Law of Cosines. Then solve the triangle. Round measures of sides to the nearest tenth and measures of angles to the nearest degree.

State the amplitude, period, and phase shift for each function. Then graph the function.

- $y = \cos(\theta + 180)$
- $y = \frac{1}{2} \tan(\theta - \frac{\pi}{2})$
- WHEELS** A water wheel has a diameter of 20 feet. It makes one complete revolution in 45 seconds. Let the height at the top of the wheel represent the height at time 0. Write an equation for the height of point h in the diagram below as a function of time t . Then graph the function.



Using a Scientific Calculator

Scientific calculators and graphing calculators are powerful problem-solving tools. As you have likely seen, some test problems that you encounter have steps or computations that require the use of a scientific calculator.

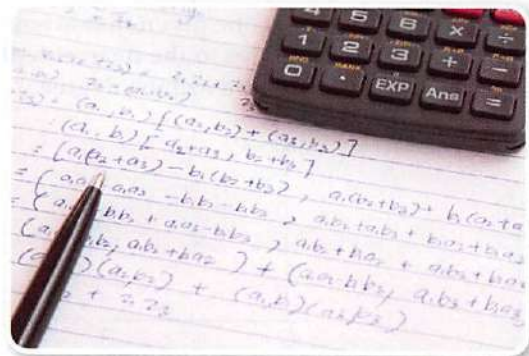

Strategies for Using a Scientific Calculator

Step 1

Familiarize yourself with the various functions of a scientific calculator as well as when they should be used.

- **Scientific notation**—for calculating large numbers
- **Logarithmic and exponential functions**—growth and decay problems, compound interest
- **Trigonometric functions**—problems involving angles, triangle problems, indirect measurement problems
- **Square roots and n th roots**—distance on a coordinate plane, Pythagorean Theorem

Step 2

Use your scientific or graphing calculator to solve the problem.

- Remember to work as efficiently as possible. Some steps may be done mentally or by hand, while others must be done using your calculator.
- If time permits, check your answer.

EXAMPLE

Read the problem. Identify what you need to know. Then use the information in the problem to solve.

When Molly stands at a distance of 18 feet from the base of a tree, she forms an angle of 57° with the top of the tree. What is the height of the tree to the nearest tenth?

- A 27.7 ft
- B 28.5 ft
- C 29.2 ft
- D 30.1 ft

Read the problem carefully. You are given some measurements and asked to find the height of a tree. It may be helpful to first sketch a model of the problem.

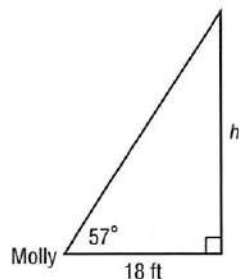

Use a trigonometric function to relate the lengths and the angle measure in the right triangle.

$$\text{tangent } \theta = \frac{\text{opposite}}{\text{adjacent}} \quad \text{Definition of tangent ratio}$$

$$\tan 57^\circ = \frac{h}{18} \quad \text{Substitute.}$$

You need to evaluate $\tan 57^\circ$ to solve for the height of a tree h . Use a scientific calculator.

$$1.53986 \approx \frac{h}{18} \quad \text{Use a calculator.}$$

$$27.71748 \approx h \quad \text{Multiply each side by 18.}$$

The height of the tree is about 27.7 feet. The correct answer is A.

Exercises

Read each problem. Identify what you need to know. Then use the information in the problem to solve.

1. An airplane takes off and climbs at a constant rate. After traveling 800 yards horizontally, the plane has climbed 285 yards vertically. What is the plane's angle of elevation during the takeoff and initial climb?
A 15.6°
B 18.4°
C 19.6°
D 22.3°

2. What is the angle of the bike ramp below?

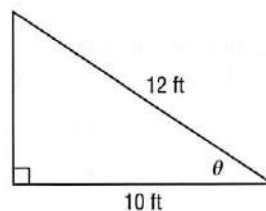

- F 26.3°
G 28.5°
H 30.4°
J 33.6°

Multiple Choice

Read each question. Then fill in the correct answer on the answer document provided by your teacher or on a sheet of paper.

1. What is the value of x ? Round to the nearest tenth if necessary.

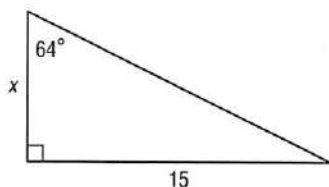

- A 6.5
B 6.9
C 7.1
D 7.3
2. Marvin rides his bike at a speed of 21 miles per hour and can ride his training loop 10 times in the time that it takes his younger brother to complete the training loop 8 times. Which is a reasonable estimate for Marvin's younger brother's speed?
- F between 14 mph and 15 mph
G between 15 mph and 16 mph
H between 16 mph and 17 mph
J between 17 mph and 18 mph
3. Suppose a Ferris wheel has a diameter of 68 feet. The wheel rotates 12° each time a new passenger is picked up. How far would you travel when the wheel rotates 12° ? Round to the nearest tenth if necessary.
- A 7.1 ft
B 7.5 ft
C 7.8 ft
D 8.2 ft
4. What is the slope of a line parallel to $y - 2 = 4(x + 1)$?
- F -4
G $-\frac{1}{4}$
H $\frac{1}{4}$
J 4
5. What is the exact value of $\sin 240^\circ$?
- A $-\frac{\sqrt{2}}{3}$
B $\frac{\sqrt{2}}{3}$
C $-\frac{\sqrt{3}}{2}$
D $\frac{\sqrt{3}}{2}$

6. What is the solution of the system of equations shown below?

$$\begin{cases} x - y + z = 0 \\ -5x + 3y - 2z = -1 \\ 2x - y + 4z = 11 \end{cases}$$

- F $(0, 3, 3)$
G $(2, 5, 3)$
H no solution
J infinitely many solutions

Test-Taking Tip

Question 7 Use the Law of Sines to solve the triangle.

7. Find m in triangle MNO if $n = 12.4$ centimeters, $M = 35^\circ$, and $N = 74^\circ$. Round to the nearest tenth.
- A 7.4 cm
B 7.8 cm
C 8.1 cm
D 8.5 cm
8. The results of a recent poll are organized in the matrix.

	For	Against
Proposition 1	1553	771
Proposition 2	689	1633
Proposition 3	2088	229

Based on these results, which conclusion is NOT valid?

- F There were 771 votes cast against Proposition 1.
G More people voted against Proposition 1 than voted for Proposition 2.
H Proposition 2 has little chance of passing.
J More people voted for Proposition 1 than for Proposition 3.
9. The graph of which of the following equations is symmetrical about the y -axis?
- A $y = x^2 + 3x - 1$
B $y = -x^2 + x$
C $y = 6x^2 + 9$
D $y = 3x^2 - 3x + 1$
10. What is the remainder when $x^3 - 7x + 5$ is divided by $x + 3$?
- F -11
G -1
H 1
J 11