



Section 6

Current, Voltage, and Resistance in Parallel and Series Circuits: Who's in Control?

What Do You See?



Click Here

Learning Outcomes

In this section, you will

- Assemble a switch in a circuit with parallel components to control a particular lamp.
- Use the conservation of energy to determine how currents and voltages are distributed in series and parallel circuits.
- Use Ohm's law to derive equations for the total resistance of multiple resistors in series and parallel circuits.

What Do You Think?

Many electrical switches are operated manually (by hand), and many others are automatic, turning appliances on and off in response to a variety of conditions.

- List at least three different kinds of automatic switching devices.
- What are the conditions that cause the on/off action of the switch?

Record your ideas about these questions in your *Active Physics* log. Be prepared to discuss your responses with your small group and the class.

Investigate

1. Assemble the circuit as shown in the diagram at the top of the next page. Each number corresponds to a different wire. You may wish to place masking tape on each wire with the corresponding number on it.



Section 6

Current, Voltage, and Resistance in Parallel and Series Circuits: Who's in Control?

What Do You See?

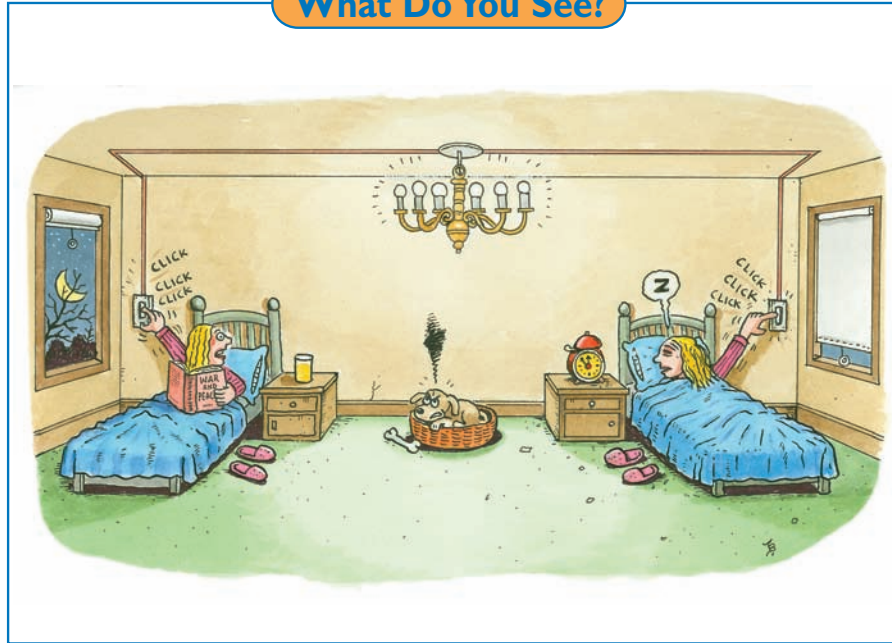

Learning Outcomes

In this section, you will

- **Assemble** a switch in a circuit with parallel components to control a particular lamp.
- **Use** the conservation of energy to determine how currents and voltages are distributed in series and parallel circuits.
- **Use** Ohm's law to derive equations for the total resistance of multiple resistors in series and parallel circuits.

What Do You Think?

Many electrical switches are operated manually (by hand), and many others are automatic, turning appliances on and off in response to a variety of conditions.

- List at least three different kinds of automatic switching devices.
- What are the conditions that cause the on/off action of the switch?

Record your ideas about these questions in your *Active Physics* log. Be prepared to discuss your responses with your small group and the class.

Investigate

1. Assemble the circuit as shown in the diagram at the top of the next page. Each number corresponds to a different wire. You may wish to place masking tape on each wire with the corresponding number on it.

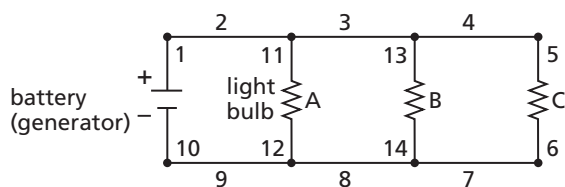

a) Draw a diagram of the circuit. Label the bulbs: A, B, C in your log. Copy the diagram in pencil (you will need to do some erasing later). Notice that the diagram shows 14 different wires. It is sometimes easier to place switches into circuits if you use a few additional wires in the circuit.

2. Compare the circuit you assembled with the one in the following diagram that shows the circuit you used in *Section 3*.

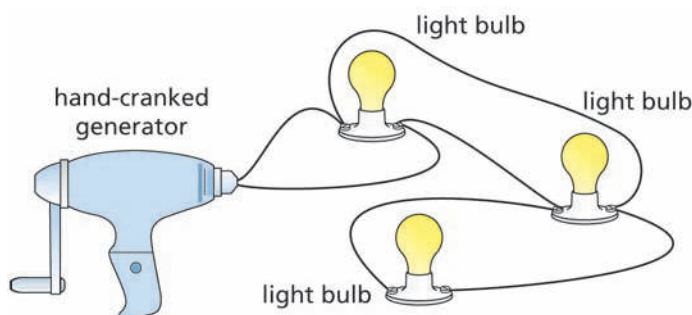

Connect the battery to be sure that all bulbs operate in the circuit you assembled in *Step 1*.

a) Identify the additional new wires on your circuit diagram from *Step 1.a*).

b) What type of circuit (series or parallel) is represented in both diagrams?

3. Predict which wire in the schematic diagram from *Step 1.a*) should be replaced with a switch if you wished to turn all three bulbs on and off. (There will be more than one correct answer.)



Before you proceed with any of the following steps, have your teacher approve the circuit that you have set up.

a) Record your prediction in your log.

b) Replace that wire with a switch. Does it work as predicted?

4. Predict which wire could be replaced with a switch if you wished to turn only bulb A on and off? (There will be more than one correct answer.)

a) Record your prediction in your log.

b) Replace that wire with a switch. Does it work as predicted?

c) Mark the location of the switch on the circuit diagram in your log by writing “switch A” and drawing an arrow from the word “switch A” to the place where the switch should be placed. Erase the wire you took out of the circuit diagram and replace it with the symbol for a switch.

5. Repeat *Step 4* for bulb B and then for bulb C.

a) Remember to record your predictions.

b) Replace the wire you chose with a switch. Are your predictions beginning to improve?

c) Draw two additional diagrams to show the location of switch B and switch C.

6. Placing a voltmeter in the circuit to measure the voltage across any light bulb is relatively simple. Take the two wires from the voltmeter and place them on the two sides of any light bulb. The positive side of the voltmeter should be closer to the positive side of the battery. If you inadvertently reverse the wires, you will note a negative voltage, or see the needle attempt to go below zero. The voltmeter is always placed in parallel with the resistor (light bulb). Place the voltmeter and measure the voltage across the first bulb.

7. Placing an ammeter in the circuit to measure the current through a light bulb is similar to placing a switch next to the bulb to control it.



The ammeter is always placed in series with the resistor (light bulb). Place the ammeter and measure the current through the first bulb.

An ammeter and a voltmeter in place to measure the current and voltage of the second resistor.

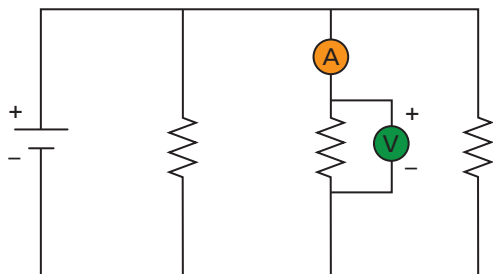

- a) Record your measurements in a table in your *Active Physics* log.
 - b) Measure and record the voltage and current in the other two bulbs.
8. Measure the total voltage and current in the circuit.

	V	I
Total		
R_1		
R_2		
R_3		

- a) Predict where you should place the meters to measure the total voltage and current. Draw a circuit diagram showing where the meters should be placed.
- b) After your teacher approves your circuit, measure and record the total voltage and current.

Physics Talk

RELATING CURRENT, VOLTAGE, AND RESISTANCE IN SERIES AND PARALLEL CIRCUITS

Multiple resistors, such as light bulbs, can be set up in series or parallel. The properties of the series and parallel circuits are quite different. Light bulbs in series will all go out when one bulb is removed. Light bulbs in parallel will remain on when one bulb is removed.

In this *Physics Talk*, you will read about the principles of current and voltage in series and parallel circuits. You will also be introduced to the equations for relating total current, total voltage, and total resistance in both series and parallel circuits. It will be helpful to recall the model you created when you did the Electron Shuffle as you read each part.

In the *Active Physics Plus*, you will see how you can combine the equations for total current and total voltage with Ohm's law to derive the equations for total resistance in both series and parallel circuits.

Switches

In the *Investigate*, you learned how switches could control which resistors in a parallel circuit will get current. Regardless of how an electrical switch may be activated, most switches work in the same basic way. Switches are always in series with the device they control. When a switch is "on," a good conductor of electricity, usually copper, is provided as the path for

current flow through the switch. Then, the circuit containing the switch is said to be "closed," and the current flows. When a switch is turned "off," the conducting path through the switch is replaced by an air gap. Since air has very high resistance, the current flow through the switch is interrupted, and the circuit is said to be "open."

Current in a Series Circuit

The current, measured in amperes (A), in an electrical circuit, is a measure of the amount of charge that flows past a given point in a given amount of time. One ampere is defined as one coulomb per second. In the Electron-Shuffle model, each person represented one coulomb of charge. The current was defined as the number of students (coulombs) that moved past a point every second. The charge that flows into one end of a wire must flow out the other end of the wire. In a series circuit, the current that goes through the first light bulb must go through the second light bulb, and then through the third light bulb. Think of how all of the charges went through all of the light bulbs in the Electron Shuffle when the light bulbs were in series. The circuit diagram above shows a circuit with three bulbs in series. The same 1-A current flows through each bulb, even if the bulbs are not identical. The following equation describes this relationship (T stands for total).

$$I_T = I_1 = I_2 = I_3$$

Current in a Parallel Circuit

In a parallel circuit, the current splits at certain junctions and then joins together at other junctions. The current entering any junction must equal the current leaving that junction if charge is to be conserved. Consider a circuit with three identical light bulbs in parallel. Since the bulbs are identical they have equal currents flowing through them. Assume that the total current in the circuit is 9 A, so that 3 A must flow through each light bulb. You can see that 9 A of current enter junction A, and two currents, a 3-A and 6-A (a total of 9 A) leave the junction. The current that goes into a junction is equal to the current that comes out of that junction. This is true everywhere in the circuit. At junction D, 9 (3 + 6) A enter and 9 A exit.

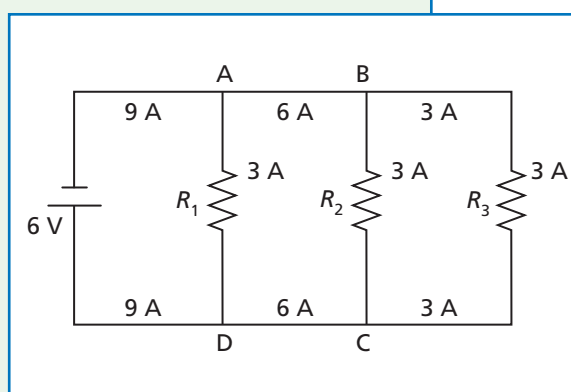
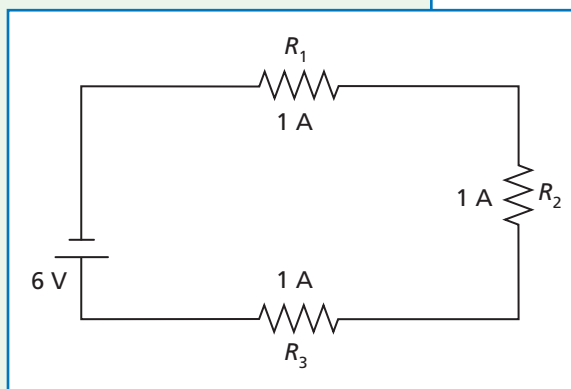



In the next parallel circuit diagram, the 9 A are shown in packets of 3 A, with each packet a different color. You can see how the packets of charge split at the junctions and then join again as they approach the battery.

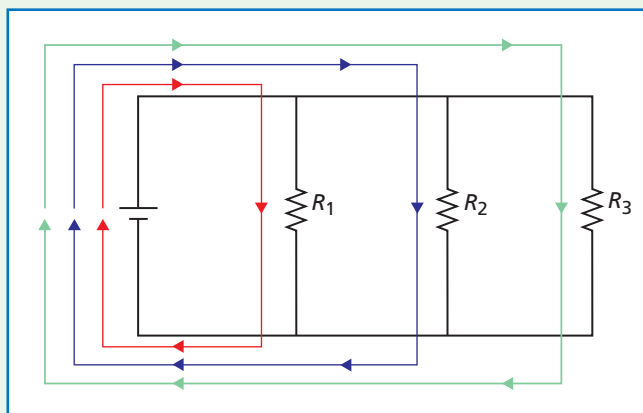

The total current leaving the battery is equal to sum of the currents through the paths in the parallel circuit.

$$I_T = I_1 + I_2 + I_3$$

Your measurements of the current in the investigation provided experimental evidence of this relationship.

Voltage in a Series Circuit

The voltage (also called the potential difference), measured in volts, is a measure of the energy per charge. One volt is defined as one joule per coulomb. The battery provides a certain amount of energy to every coulomb of charge. The energy in the circuit is distributed to the resistors (lamps or appliances) in the circuit.

In a series circuit, all of the charges go through all of the resistors, so the current going through each light bulb in the figure must be the same ($I_1 = I_2 = I_3$). If the three resistors are identical, as in the Electron Shuffle, each resistor will get the same energy. If a battery provides 6 V, then 2 V are transferred to the first resistor, 2 V are transferred to the second resistor, and 2 V are transferred to the third resistor. However, if the resistors are different, each will get a different amount of the energy. For example, if a 6-V battery is used, 2 V may be transferred to the first resistor, 3 V to the second resistor, and 1 V to the third resistor. In either case, the sum of the voltages must total the voltage of the battery. The following equation describes this relationship.

$$V_T = V_1 + V_2 + V_3$$

This is a statement about the conservation of energy. The battery provides a certain amount of energy to each coulomb of charge. This energy is then distributed to the three resistors.

Voltage in a Parallel Circuit

In a parallel circuit, the charges that go through one resistor do not go through any other resistor. All of the energy of that charge must be transferred to that one resistor, as we saw in the Electron Shuffle investigation. If a battery provides 6 V, then 6 V must be transferred to each resistor. For instance, in the circuit with the three light bulbs in parallel, each bulb sees the same voltage, 6 V. The following equation describes this relationship.

$$V_T = V_1 = V_2 = V_3$$

Your measurements of the voltages of each bulb in the investigation provided experimental evidence across this relationship.

Resistance in Series and Parallel Circuits

Combining the equations above and Ohm's law, it is possible to derive equations that relate total resistance in series and parallel circuits. The following equation describes this relationship for a series circuit.

$$R_T = R_1 + R_2 + R_3$$

The following equation describes this relationship for a parallel circuit.

$$\frac{1}{R_T} = \frac{1}{R_1} + \frac{1}{R_2} + \frac{1}{R_3}$$

The *Active Physics Plus* shows you how these equations were derived.

Series Circuit Summary

All components have the same (equal) current.

$$I_T = I_1 = I_2 = I_3$$

Voltage drops add to equal total voltage.

$$\text{Voltage: } V_T = V_1 + V_2 + V_3$$

Resistances add to equal total resistance. The more resistors in the circuit, the larger the total resistance.

$$\text{Resistance: } R_T = R_1 + R_2 + R_3$$

Ohm's law: Ohm's law can be applied to the entire circuit or to any resistor in the circuit.

$$V_T = I_T R_T \quad V_1 = I_T R_1 \quad V_2 = I_T R_2 \quad V_3 = I_T R_3$$

Power: Power can also be calculated for the entire circuit or for any resistor in the circuit.

$$P_T = V_T I_T \quad P_1 = V_1 I_1 \quad P_2 = V_2 I_2 \quad P_3 = V_3 I_3$$





Parallel Circuit Summary

Currents through each component add to equal total current.

$$\text{Current: } I_T = I_1 + I_2 + I_3$$

All components have the same (equal) voltage.

$$\text{Voltage: } V_T = V_1 = V_2 = V_3$$

The more resistors in the circuit, the smaller the total resistance of the circuit.

$$\text{Resistance: } \frac{1}{R_T} = \frac{1}{R_1} + \frac{1}{R_2} + \frac{1}{R_3}$$

Ohm's law: Ohm's law can be applied to the entire circuit or to any resistor in the circuit.

$$V_T = I_T R_T \quad V_1 = I_1 R_1 \quad V_2 = I_2 R_2 \quad V_3 = I_3 R_3$$

Power: Power can also be calculated for the entire circuit or for any resistor in the circuit.

$$P_T = V_T I_T \quad P_1 = V_1 I_1 \quad P_2 = V_2 I_2 \quad P_3 = V_3 I_3$$

Sample Problem I

Given the following series circuit, find:

- the total resistance
- the total current
- the current through each resistor
- the voltage across each resistor
- the total power
- the power dissipated by each resistor

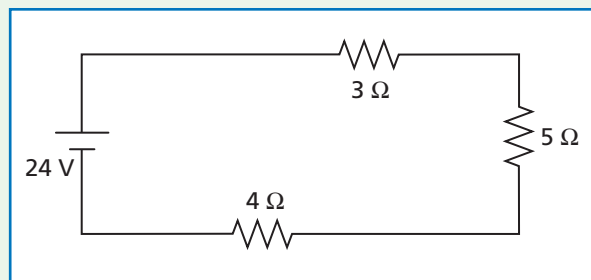

Strategy: This is a series circuit. All the current goes through each of the resistors. First calculate the total resistance. Then, using Ohm's law, calculate the total current. You can also use Ohm's law to calculate the voltage across each resistor. Then, using the equation for power, calculate the total power and the power through each resistor.

Given:

$$V = 24 \text{ V}$$

$$R_1 = 3 \ \Omega$$

$$R_2 = 5 \ \Omega$$

$$R_3 = 4 \ \Omega$$

Solution:

a) Total resistance:

$$\begin{aligned} R_T &= R_1 + R_2 + R_3 \\ &= 3 \ \Omega + 5 \ \Omega + 4 \ \Omega \\ &= 12 \ \Omega \end{aligned}$$

b) Total current:

$$\begin{aligned} V_T &= I_T R_T \\ I_T &= \frac{V_T}{R_T} \\ &= \frac{24 \text{ V}}{12 \ \Omega} \\ &= \frac{24 \cancel{\text{V}}}{12 \ \cancel{\text{V}}/\text{A}} \\ &= 2 \text{ A} \end{aligned}$$

c) You know that the total current is 2 A. In a series circuit, $I_T = I_1 = I_2 = I_3$, so the current through each resistor is 2 A.

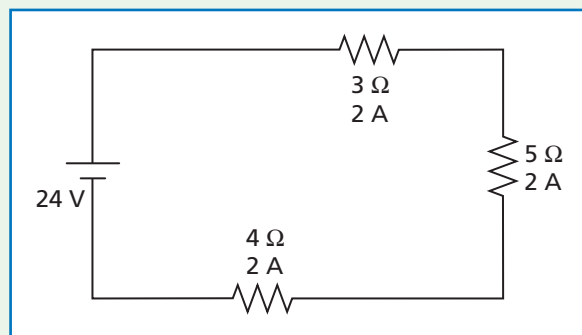

It is helpful to place this information in the diagram.

When you do your dimensional analysis, recall:

- Current (I) is measured in amps (A), which are equivalent to coulombs per second (C/s).
- Voltage (V) is measured in volts (V), which are equivalent to joules per coulomb (J/C).
- Resistance (R) is measured in ohms (Ω), which are equivalent to volts per amp (V/A).
- Power (P) is measured in watts (W), which are equivalent to joules per second (J/s).





- d) Once you know two of the four variables (V , I , P , R), you can find the other two variables. In this case, you know I and R and can find the voltage using Ohm's law for each resistor.

$$\begin{array}{lll} V_1 = I_1 R_1 & V_2 = I_2 R_2 & V_3 = I_3 R_3 \\ V_1 = (2 \text{ A})(3 \Omega) & V_2 = (2 \text{ A})(5 \Omega) & V_3 = (2 \text{ A})(4 \Omega) \\ V_1 = 6 \text{ V} & V_2 = 10 \text{ V} & V_3 = 8 \text{ V} \end{array}$$

Notice the sum of the voltage drops:

$$6 \text{ V} + 10 \text{ V} + 8 \text{ V} = 24 \text{ V}$$

This is the voltage supplied by the battery.

- e) You can now find the total power.

$$\begin{aligned} P_T &= V_T I_T \\ &= (24 \text{ V})(2 \text{ A}) \\ &= 48 \text{ W} \end{aligned}$$

$$\begin{array}{lll} \text{f) } P_1 = V_1 I_1 & P_2 = V_2 I_2 & P_3 = V_3 I_3 \\ P_1 = (6 \text{ V})(2 \text{ A}) & P_2 = (10 \text{ V})(2 \text{ A}) & P_3 = (8 \text{ V})(2 \text{ A}) \\ P_1 = 12 \text{ W} & P_2 = 20 \text{ W} & P_3 = 16 \text{ W} \end{array}$$

Notice the sum of the power in the resistors:

$$12 \text{ W} + 20 \text{ W} + 16 \text{ W} = 48 \text{ W}$$

That is the power supplied by the battery.

It is often useful to draw the circuit diagram and to place the values you calculate directly on the diagram to help keep track of all the variables.

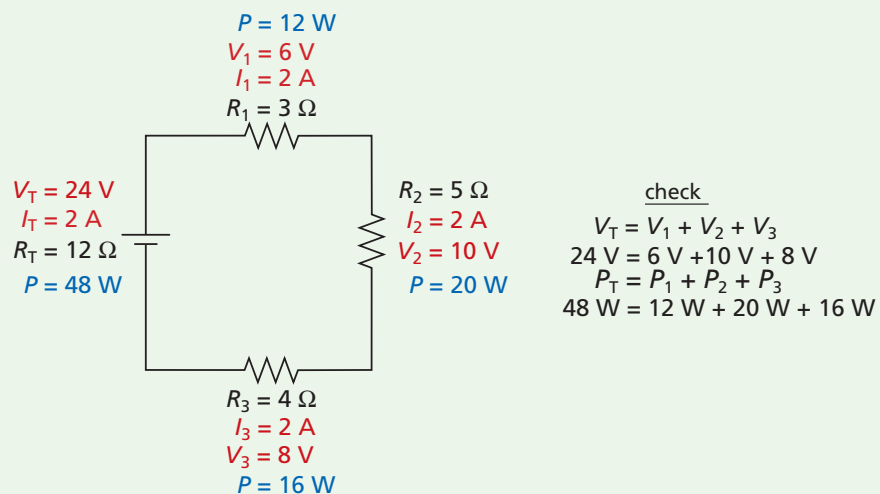

Sample Problem 2

Given the following parallel circuit, find:

- the current through each resistor
- the total current
- the total power
- the power in each resistor
- the total resistance

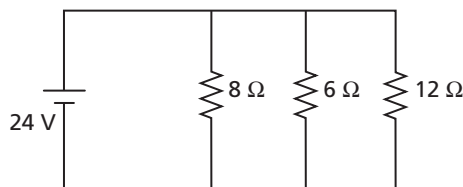

Strategy: This is a parallel circuit. The current follows different paths to each resistor. In a parallel circuit, the voltage drops across each resistor are equal. In this case, the voltage of each resistor equals 24 V.

$$V_T = V_1 = V_2 = V_3 = 24 \text{ V}$$

You can put this information in the diagram immediately.

Once you know two of the four variables (V , I , P , R), you can find the other two variables. In this case, you know V and R . You can find the current using Ohm's law for each resistor.

Solution:

a) $V = IR$

$$I = \frac{V}{R}$$

$$I_1 = \frac{V_1}{R_1} \quad I_2 = \frac{V_2}{R_2} \quad I_3 = \frac{V_3}{R_3}$$

$$I_1 = \frac{24 \text{ V}}{8 \Omega} \quad I_2 = \frac{24 \text{ V}}{6 \Omega} \quad I_3 = \frac{24 \text{ V}}{12 \Omega}$$

$$I_1 = 3 \text{ A} \quad I_2 = 4 \text{ A} \quad I_3 = 2 \text{ A}$$

- b) You can find the total current by adding the currents through each resistor. If the resistors have currents of 3 A, 4 A, and 2 A, then the total current must be equal to $3 \text{ A} + 4 \text{ A} + 2 \text{ A} = 9 \text{ A}$.

- c) Use the power equation to calculate the power once you know the current.

$$\begin{aligned} P_T &= V_T I_T \\ &= (24 \text{ V})(9 \text{ A}) \\ &= 216 \text{ W} \end{aligned}$$

$$\begin{aligned} \text{d) } P_1 &= V_1 I_1 & P_2 &= V_2 I_2 & P_3 &= V_3 I_3 \\ P_1 &= (24 \text{ V})(3 \text{ A}) & P_2 &= (24 \text{ V})(4 \text{ A}) & P_3 &= (24 \text{ V})(2 \text{ A}) \\ P_1 &= 72 \text{ W} & P_2 &= 96 \text{ W} & P_3 &= 48 \text{ W} \end{aligned}$$

Notice the sum of the power in the resistors:

$$72 \text{ W} + 96 \text{ W} + 48 \text{ W} = 216 \text{ W}$$

That is the power supplied by the battery. 



- e) You can find the total resistance of the circuit easily by using Ohm's law for the entire circuit

$$\begin{aligned} V_T &= I_T R_T \\ R_T &= \frac{V_T}{I_T} \\ &= \frac{24 \text{ V}}{9 \text{ A}} \\ &= 2.67 \Omega \text{ (or about } 3 \Omega) \end{aligned}$$

You can also find the total resistance by adding the individual resistors in parallel. Notice that in this equation, you are dealing with fractions.

$$\begin{aligned} \frac{1}{R_T} &= \frac{1}{R_1} + \frac{1}{R_2} + \frac{1}{R_3} \\ &= \frac{1}{8 \Omega} + \frac{1}{6 \Omega} + \frac{1}{12 \Omega} \end{aligned}$$

Using the least common denominator of 24: Notice that the total resistance is less than any single resistance in the parallel circuit. This is

$$\begin{aligned} \frac{1}{R_T} &= \frac{3}{24 \Omega} + \frac{4}{24 \Omega} + \frac{2}{24 \Omega} \\ &= \frac{9}{24 \Omega} \\ R_T &= 2.67 \Omega \text{ (or about } 3 \Omega) \end{aligned}$$

always true and agrees with the simpler method above, as it must. You can keep track of all values you calculate on a circuit diagram.

Checking Up

- Are switches connected in series or parallel with the devices they control?
- Would a switch be used in a series or parallel circuit if you wanted to turn off one of several light bulbs?
- What is the resistance of a switch when it is open? When it is closed?

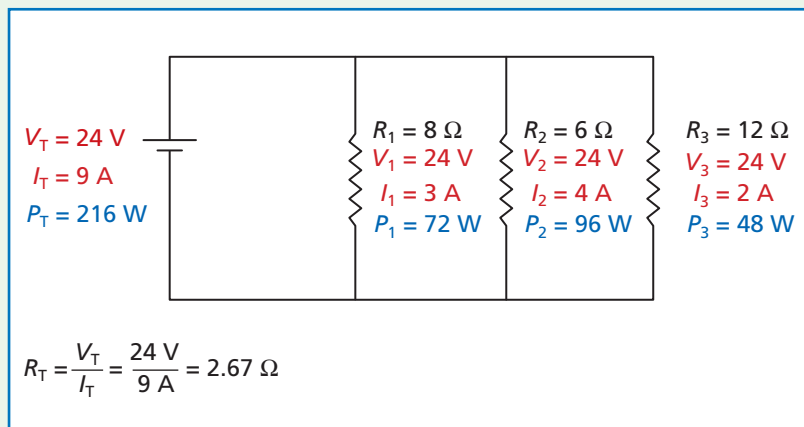

Active Physics

+Math	+Depth	+Concepts	+Exploration
♦♦	♦♦		

Plus

Deriving the Equation to Calculate Total Resistance in Series and Parallel Circuits

Series and parallel circuits distribute the current and voltage differently and require different analysis.

Series Circuits with Three Resistors

In a series circuit

$$\text{Current} \quad I_T = I_1 = I_2 = I_3$$

$$\text{Voltage} \quad V_T = V_1 + V_2 + V_3$$

Ohm's law can be applied to the entire circuit or to any resistor in the circuit.

$$V_T = I_T R_T$$

$$V_1 = I_1 R_1$$

$$V_2 = I_2 R_2$$

$$V_3 = I_3 R_3$$

Combining these equations yields an equation that relates the total resistance to the individual resistors in a series circuit.

$$V_T = V_1 + V_2 + V_3$$

$$I_T R_T = I_1 R_1 + I_2 R_2 + I_3 R_3$$

$$\text{Since } I_T = I_1 = I_2 = I_3$$

$$I_T R_T = I_T R_1 + I_T R_2 + I_T R_3$$

$$I_T R_T = I_T (R_1 + R_2 + R_3)$$

$$R_T = R_1 + R_2 + R_3$$

Parallel Circuits with Three Resistors

In a parallel circuit

$$\text{Current} \quad I_T = I_1 + I_2 + I_3$$

$$\text{Voltage} \quad V_T = V_1 = V_2 = V_3$$

Ohm's law can be applied to the entire circuit or to any resistor in the circuit.

$$V_T = I_T R_T$$

$$V_1 = I_1 R_1$$

$$V_2 = I_2 R_2$$

$$V_3 = I_3 R_3$$

Combining these equations yields an equation that relates the total resistance to the individual resistors in a parallel circuit.

$$I_T = I_1 + I_2 + I_3$$

$$\frac{V_T}{R_T} = \frac{V_1}{R_1} + \frac{V_2}{R_2} + \frac{V_3}{R_3}$$

$$\text{Since } V_T = V_1 = V_2 = V_3$$

$$\frac{V_T}{R_T} = \frac{V_T}{R_1} + \frac{V_T}{R_2} + \frac{V_T}{R_3}$$

$$\frac{1}{R_T} = \frac{1}{R_1} + \frac{1}{R_2} + \frac{1}{R_3}$$

The more resistors you add in parallel the smaller is the total resistance of the circuit. This is because each resistor in parallel provides another pathway for the current to flow, resulting in more total current for the same voltage. That is why circuit breakers and fuses are needed in a household circuit to limit the total current in the circuit.



1. As identical resistors are added in a series circuit, the total resistance changes. Graph the total resistance of a series circuit versus the number of $12\text{-}\Omega$ resistors in the circuit.
2. As identical resistors are added in a parallel circuit, the total resistance changes. Graph the total resistance of a parallel circuit versus the number of $12\text{-}\Omega$ resistors in the circuit.
3. In a parallel circuit, the total resistance is always smaller than any of the individual resistors.
 - a) Show that this is true for a circuit with $1\text{-}\Omega$, $10\text{-}\Omega$, and $20\text{-}\Omega$ resistors.
 - b) Show that this is true for a circuit with two unknown resistors.

4. Shown below is a series/parallel circuit.
 - a) Calculate the total resistance of the series/parallel circuit shown below.
 - b) Calculate the current through each resistor.
 - c) Calculate the voltage across each resistor.

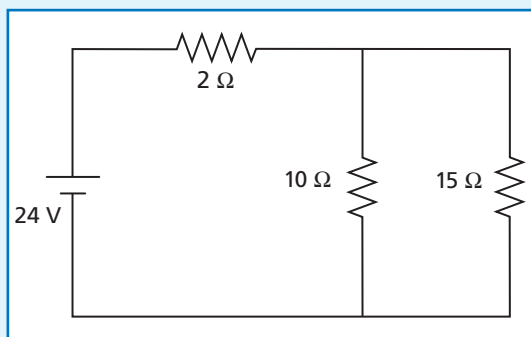

What Do You Think Now?

At the beginning of this section, you were asked:

- List at least three different kinds of automatic switching devices.
- What are the conditions that cause the on/off action of the switch?

Now that you have completed this section, how would you answer these questions?



Physics

Essential Questions

What does it mean?

Explain how the voltage of each light bulb in a parallel circuit can be equal to the voltage of the power source.

How do you know?

What experimental evidence do you have that the voltage across each light bulb in a parallel circuit is equal to the voltage of the battery?

Why do you believe?

Connects with Other Physics Content	Fits with Big Ideas in Science	Meets Physics Requirements
Electricity and magnetism	* Conservation laws	Experimental evidence is consistent with models and theories

* Conservation of energy is one of the major organizing principles of physics. How can the voltage relationship of the individual resistors and the voltage of the battery in both series and parallel circuits be explained in terms of energy conservation?

Why should you care?

Circuits in your home make use of both series and parallel circuits. How can your knowledge of circuits be expressed in a meaningful way in your training manual?

Reflecting on the Section and the Challenge

Part of the problem you are facing with the electrical system for the Homes For Everyone (HFE) dwellings is to assure that the people who live in them will not exceed the 2400 W power limit of the system by having too many appliances in use at any one time. Depending on what you choose to include in the HFE appliance package, it may be necessary to use switching devices—automatic, manual, or both—to assure that the people who live in the homes will stay within the power limit as they use their appliances.

Perhaps you could also use automatic switches as “fail safe” devices to prevent accidentally using up too much electrical energy by, for example, forgetting to shut off lights that are not in use.

You may decide that you want a switch to turn off all lights and appliances in a room. Alternatively, you may decide that a certain appliance should never be turned off. You now know how to set up circuits and switches with these properties.

Your calculations of current can help you to prevent a fuse from blowing. You can now explain in your manual how the total current varies as more and more appliances are added in parallel. Your understanding of current, voltage and resistance calculations can guide your explanations in your manual.



Physics to Go

- In your log, describe several possibilities for using switching devices to address the power limit problem in your universal dwelling. Write your ideas in your log.
- Electric switches are available which act as timers to turn appliances on and off at chosen times or for chosen intervals. Identify one or more ways a timer switch would be useful in an HFE dwelling.

- Look at the wiring diagrams shown. Copy each into your log. Position and draw a single switch in each circuit that would allow you to have two lights on all the time, and one light that you could turn on or off.

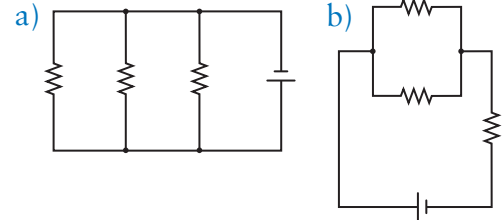

- A 15-V battery is hooked up to three resistors in series. The voltage drop across the first resistor is 3 V and the voltage drop across the second resistor is 10 V. What is the voltage drop across the last resistor?
- A 15-V battery is hooked up to three identical resistors in series. What is the voltage across each resistor?
- A 15-V battery is hooked up to three identical resistors in parallel. What is the voltage across each resistor?
- In each of the circuits below, all the ammeters (denoted with circles surrounding an A) but one have the current displayed. What is the current in the unknown ammeter?

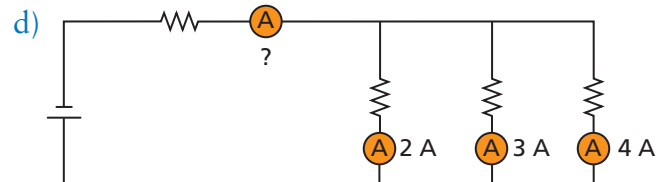
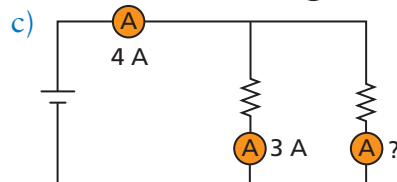
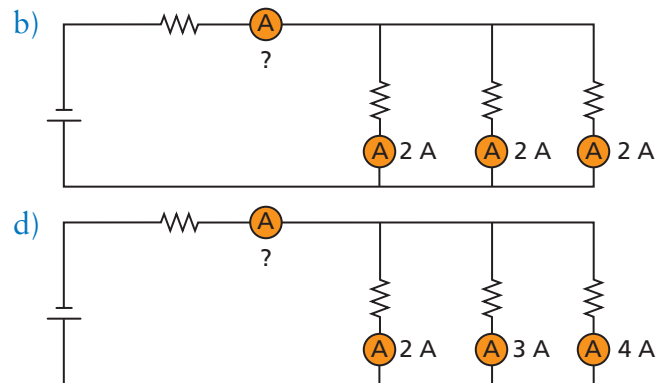
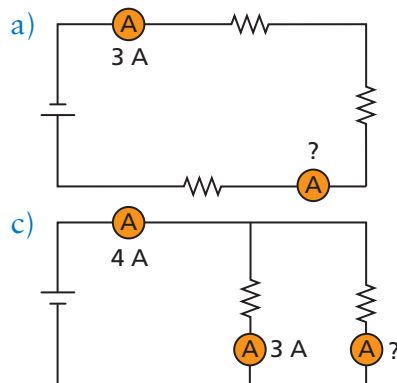

- Three resistors are hooked up in series. The voltage drops across the resistors are 4 V, 8 V, and 2 V. The current through the first resistor is 2 A.
 - What is the voltage of the battery?
 - What is the current through the second resistor?
- Two identical resistors are hooked up in parallel. The total voltage of the circuit is 6 V. The total current of the circuit is 2 A.
 - What is the voltage drop across each resistor?
 - What is the current through each resistor?

10. Three resistors of $12\ \Omega$, $14\ \Omega$, and $4\ \Omega$ are connected in series to a 12-V power supply. Find
- the total resistance of the circuit
 - the current flowing through each resistor
 - the voltage drop across each resistor
11. Three resistors of $8\ \Omega$, $6\ \Omega$, and $4\ \Omega$ are connected in series to a battery of six 1.5-V dry cells, which are also connected in series. (Remember when you added batteries in series in the Electron Shuffle?)
- Draw a circuit diagram for this situation.
 - Calculate the total voltage provided by the battery.
 - Calculate the total resistance.
 - Find the total current.
 - What is the voltage drop across each individual resistor?

12. The table to the right represents a set of three resistors arranged in series. Draw a diagram of the circuit. Then use the facts that you know about series circuits to fill in the empty spaces.

	V	I	R
Total	120 V		
R_1			$10\ \Omega$
R_2			$5\ \Omega$
R_3			$25\ \Omega$

13. A $6\text{-}\Omega$, $3\text{-}\Omega$, and $18\text{-}\Omega$ resistor are connected in parallel to an 18-V power supply. Draw a diagram of the circuit. Make and complete a chart like the one in the previous problem. Find
- the total resistance of the circuit
 - the total current through the circuit
 - the current flowing through each resistor
14.  You are given three $10\text{-}\Omega$ resistors by your teacher. You are told to arrange them in the following ways. Sketch a diagram for each arrangement and make a table with the given values. Complete each chart by finding the unknown values. What values will you have for total resistance in each case?
- All three resistors in series.
 - All three resistors in parallel.
 - One resistor in series and two in parallel.
 - Two resistors in series with one in parallel.
- (Hint: In a combination series/parallel circuit, always simplify the parallel resistors first, then the series combinations.)



15. The table to the right represents a set of three resistors arranged in parallel. Draw a diagram of the circuit. Then use the facts that you know about parallel circuits to fill in the empty spaces.

	V	I	R
Total	24 V		
R_1			18 Ω
R_2			12 Ω
R_3			36 Ω

16. Which circuit segment below has the same total resistance as the circuit segment shown in the diagram to the right? (Hint: Whenever two resistors are placed in parallel, the combination has to be smaller than the smallest single resistor. Think about it—each time you add a resistor in parallel, you are making it easier for the charge to flow. So the total resistance always goes down when you add a new resistor.)

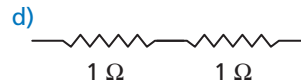
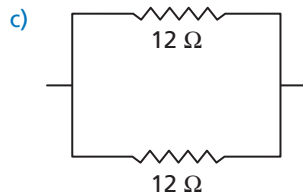
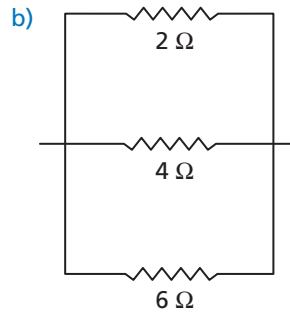
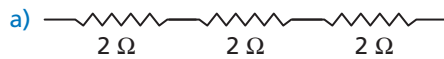
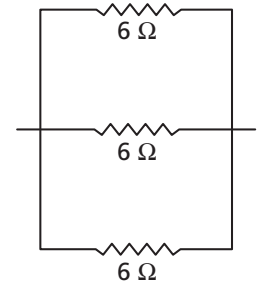

17. The diagram to the right shows the current in three branches of an electric circuit. What is the value and the direction of the current between junction P and point W?

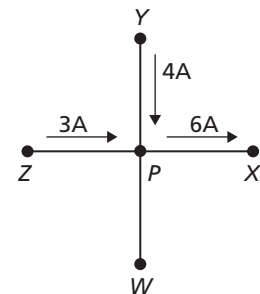

18. What is the current in the circuit represented by the diagram below?

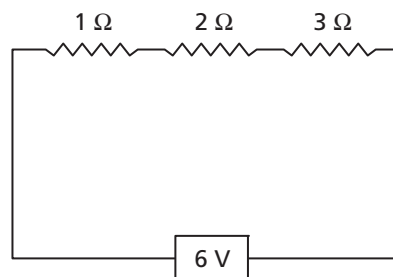

19. What is the current in the ammeter A in the diagram below?

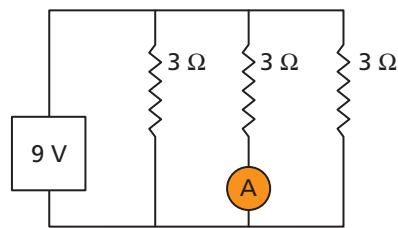

20. A mercury switch is often used as a silent switch for turning lights on and off. The mercury switch is a glass cylinder with a large drop of the liquid metal mercury inside it. When the mercury switch tilts one way, the circuit is completed. When the mercury switch tilts the other way, the circuit is open and the light goes out. Draw a design for how a mercury switch could be manufactured so that when you flip a switch the lights go on and when you lower the switch, the lights go off.

Inquiring Further

1. “Automatic” switching devices

Shop, in a store or catalog, for electrical switching devices controlled by a variety of conditions such as light/dark, high/low temperature, motion, sound, etc. The devices may be either “built-in” to appliances (e.g., the thermostat built into an oven that allows you to set the oven for a specific temperature) or separate (e.g., a clock timer designed to automatically turn lights on and off). Find as many different kinds of switching devices as you can, and note which ones may be useful for the HFE electrical system, and for what purpose. In your log, write a brief report on your findings.

2. Three-way switches

Occasionally, you want to have a light in your house controlled by two switches. For example, you may want to be able to turn a light on from the bottom of the stairs and then turn it off when you get to the top of the stairs. Later, you may want to turn it on from the top of the stairs and then off at the bottom. This is called a three-way switch.

- Design a circuit diagram for a three-way switch.
- Design a circuit diagram for a four-way switch (this has three switches that can control the same light.)