

Section 4

Ohm's Law: Putting up a Resistance

What Do You See?

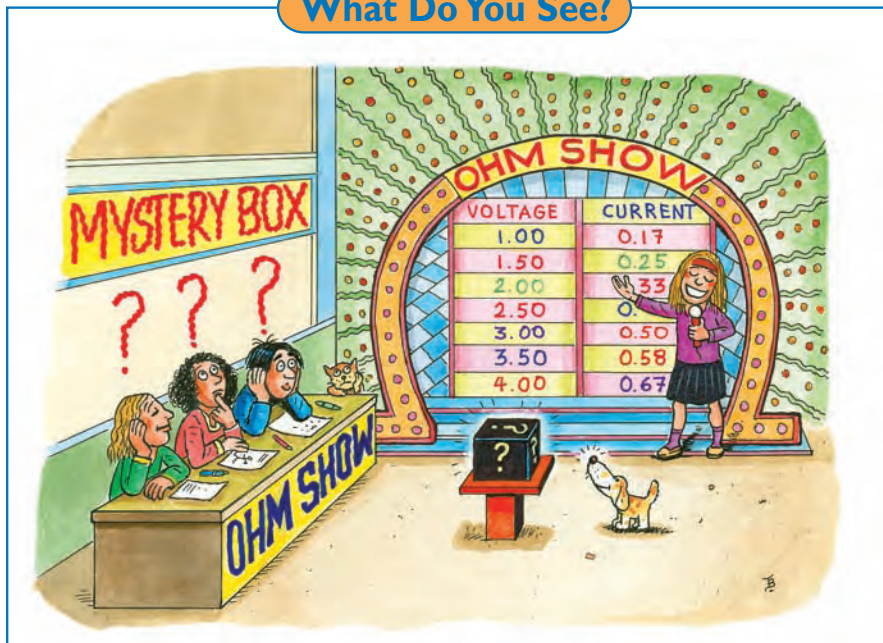

Learning Outcomes

In this section, you will

- Calculate the resistance of an unknown resistor given the voltage drop and current.
- Construct a series circuit.
- Use a voltmeter and ammeter in a series circuit accurately.
- Express the relationship between voltage and current for a resistor that obeys Ohm's law in a graph.

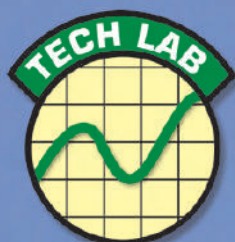

Click Here

What Do You Think?

Lighting makes some rooms conducive to work and other rooms more relaxing.

- What determines the brightness of a light bulb?
- What determines how much current flows in a circuit?

Record your ideas about these questions in your *Active Physics* log. Be prepared to discuss your responses with your small group and the class.

Investigate

Imagine a “black box,” a box that you cannot see inside. Inside the box is a resistor. In this *Investigate*, you will determine the contents of the black box electrically by measuring the voltage across and the current through the resistor inside.

1. In order to predict what is in the black box, you first will have to complete an investigation of three different resistors, a 5- Ω (ohm), a 10- Ω , and a 15- Ω resistor.

You will need to set up a simple circuit with a resistor, a voltmeter, and an ammeter, as shown in the diagram on the next page. By varying the voltage of the battery, you can learn how the current of the circuit and the voltage across a resistor changes.

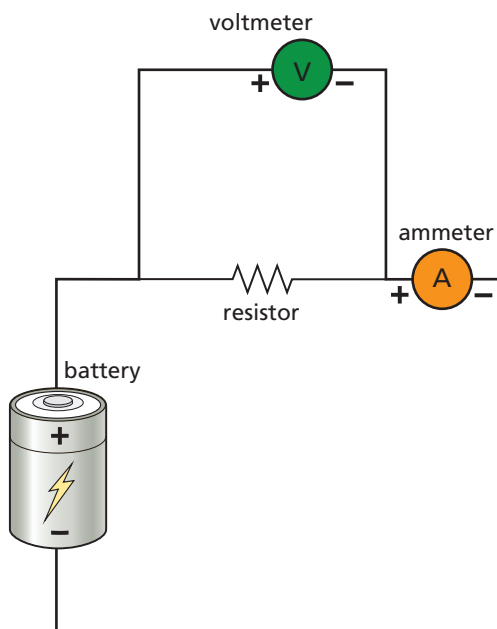

Before beginning your study, please note the following circuit rules:

- The ammeter is always placed in series in the circuit.
 - The positive terminal of the ammeter is always closest to the positive terminal of the battery.
 - The voltmeter is always placed in parallel in the circuit. The simplest way to measure the voltage drop across the resistor is to take the two leads from the voltmeter and touch the two ends of the resistor simultaneously.
 - The positive terminal of the voltmeter is always closest to the positive terminal of the battery.
 - Keep the connection in the circuit on for as long as it takes to read the ammeter and voltmeter, and no longer.
 - You can vary the voltage with a variable voltage supply or by adding additional batteries into the circuit.
2. Begin with the 5- Ω resistor. Plan your experiment to find out how the voltage and current vary for a 5- Ω resistor.

- a) Record your plan.
 - b) Make a table that will summarize the data you intend to collect.
3. After your teacher has approved your plan, conduct your experiment.
- a) Record your data for the voltage and current of the 5- Ω resistor.
4. Repeat your investigation for the 10- Ω and 15- Ω resistors.
- a) Record your data for the 10- Ω resistor.
 - b) Record your data for the 15- Ω resistor.
 - c) Given a voltage and current, how would you determine if the circuit had a 5- Ω , 10- Ω , or 15- Ω resistor?
5. A black box for a resistor yielded the following data:

Voltage (volts)	Current (amps)
1.00	0.17
1.50	0.25
2.00	0.33
2.50	0.42
3.00	0.50
3.50	0.58
4.00	0.67

- a) Did the student's circuit have a 5- Ω , 10- Ω , 15- Ω , or some other resistor?
6. Your teacher will supply you with a resistor inside a black box.
- a) Record data to determine which resistor is inside the black box. Explain how you know.
 - b) How confident are you about the contents of the black box? (1 = I have no idea; 10 = I am completely sure; nothing else is possible.)

Physics Talk

OHM'S LAW RELATES RESISTANCE TO VOLTAGE AND CURRENT

Scientists study “black boxes” all the time. A black box is an object or a phenomenon that you cannot see directly. Scientists will often define something to be a black box and describe it in terms of how it interacts with the world around it. In this section, you investigated a black box electrically to discover the resistor that was inside.

You first measured the voltage and current of three known resistors. The measurements of voltage and current showed that increasing the voltage increased the current in the circuit. This was true for all three resistors.

The ratio of the voltage to current was constant for any single resistor. For example, data of the voltage and current for the 3-Ω may have looked like the first two columns of the chart. The third column is the ratio of voltage to current.

Voltage (V)	Current (A)	Voltage Current $\frac{V}{I}$
1.00	0.33	3
1.50	0.50	3
2.00	0.67	3
2.50	0.83	3
3.00	1.00	3
3.50	1.17	3
4.00	1.33	3



Georg Simon Ohm,
a German physicist.

The ratio of the voltage to current is equal to the **electrical resistance**. This relationship is referred to as **Ohm's law**. Many resistors obey Ohm's law, which states that as the voltage increases at a fixed rate, the current increases at the same rate. This is expressed mathematically:

$$R = \frac{V}{I}$$

where R is the resistance in ohms (Ω),
 V is the voltage in volts (V), and
 I is the current in amperes (A).



Physics Words

electrical resistance: the ratio of the voltage across a conductor divided by the current.

Ohm's law: voltage increases at a fixed rate as the current increases at the same rate.



The unit of resistance is the ohm. A one-ohm resistor connected to a one-volt battery will draw one ampere of current. The symbol for ohm is the Greek letter *omega* (Ω).

This equation can be rearranged to calculate the value of any of the terms.

$$V = RI \qquad I = \frac{V}{R}$$

The helpful algebra circle can be used to solve for any of the three variables, by covering up the variable you are solving for and viewing the equation.

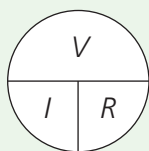

If you want to solve for voltage, cover the V and you will see that you must multiply I by R (since they are side by side).

If you want to solve for current, cover the I and you will see that you must divide V by R .

If you want to solve for resistance, cover the R and you will see that you must divide V by I .

Some resistors obey Ohm's law over a wide range of voltages. For these resistors, the value of R always remains the same.

Sample Problem

A $2\text{-}\Omega$ resistor is placed in a circuit. Record the currents corresponding to voltage measurements of 10 V and 30 V .

Strategy: You are asked to calculate current for a known resistor. You can use Ohm's law, which shows the relationship among voltage, resistance, and current.

Given: $R = 2\ \Omega$

$V = 10\text{ V}$ and 30 V

Solution: $I = \frac{V}{R}$

$$I = \frac{10\text{ V}}{2\ \Omega} = 5\text{ A}$$

$$I = \frac{30\text{ V}}{2\ \Omega} = 15\text{ A}$$

Checking Up

1. What is the name for the ratio of the voltage applied to a circuit and the current in a circuit?
2. A single $5\text{-}\Omega$ resistor is placed in a circuit that has a battery supplying 10 V . What current will flow in this circuit?
3. When the voltage is increased in a circuit with a single resistor that obeys Ohm's law, what will happen to the current in the circuit?

Dimensional Analysis and Ohm's Law

In the sample problem, you used the equation

$$I = \frac{V}{R}$$

Recall that resistance (R), measured in ohms (Ω), is the ratio of the voltage to the current, measured in $\frac{\text{V}}{\text{A}}$. Also, recall that mathematically

$$\frac{\text{V}}{\frac{\text{V}}{\text{A}}} = \cancel{\text{V}} \times \frac{\text{A}}{\cancel{\text{V}}} = \text{A}$$

Notice how the units cancel, leaving the unit for current, amperes (A).

Active Physics

+Math	+Depth	+Concepts	+Exploration
♦♦	♦♦	♦	

Plus

Graphing Ohm's Law

Ohm's law expresses the relationship between the voltage and current

$$R = \frac{V}{I}$$

For most resistors, the ratio of the voltage and current is a constant.

Recording the varying voltage and the corresponding current would allow you to make a graph. If the resistor obeys Ohm's law, the ratio of the voltage and current remains the same and the graph would be a straight line. If the current is on the x -axis and the voltage on the y -axis, the slope of the line is equal to R .

For the data given in the *Physics Talk* for a $3\text{-}\Omega$ resistor, the graph would look like the one shown.

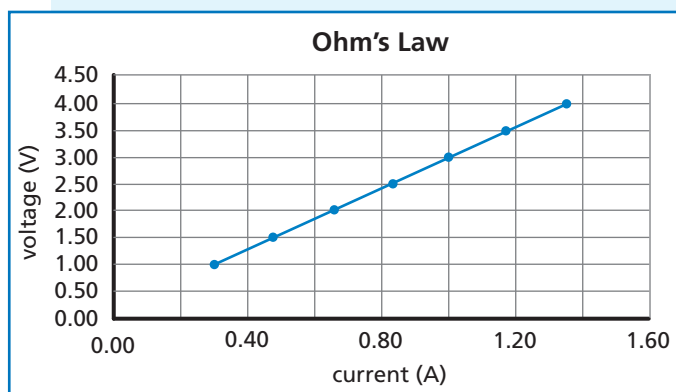

1. Calculate the slope of the line and determine if, in fact, it is equal to $3\ \Omega$.

It makes sense to calculate the slope. The equation for a straight line is $y = mx + b$, where m is the slope of the line, and b is the y -intercept. The y -axis has the value of voltage (V) and the x -axis has the values of current (I). The y -intercept is zero. Lining up the equations for a straight line and Ohm's law, you can see that the slope m is equal to the resistance (R).

$$\begin{pmatrix} y \\ V \end{pmatrix} = \begin{pmatrix} m \\ R \end{pmatrix} \begin{pmatrix} x \\ I \end{pmatrix} + b$$

Recognize that this graph is a bit unusual. Usually, the independent variable (the one you vary) goes on the x -axis and the dependent variable goes on the y -axis. If your data were plotted like that, the slope of the line would be equal to $1/V$ which is equal to $1/R$.

2. Plot the data as current versus voltage. Calculate the slope and determine if, in fact, it is equal to $1/(3\text{-}\Omega)$.
3. Using either the V - I format or the I - V format, graph the data from the three resistors, $3\ \Omega$, $10\ \Omega$, and $15\ \Omega$ on a single graph.

What Do You Think Now?

Lighting makes some rooms conducive to work and other rooms more relaxing.

- What determines the brightness of a light bulb?
- What determines how much current flows in a circuit?

How would you answer these questions now? What else would you think you need to know to answer the questions more completely?



Physics

Essential Questions

What does it mean?

What is Ohm's law?

How do you know?

How do you know that Ohm's law is a valid description of the relationship between voltage, current and resistance?

Why do you believe?

Connects with Other Physics Content	Fits with Big Ideas in Science	Meets Physics Requirements
Electricity and magnetism	Models	* Experimental evidence is consistent with models and theories

* In physics, mathematical models are created that express relationships between quantities. Explain why you believe that Ohm's law can be applied to a wide variety of objects.

Why should you care?

How will you use Ohm's law to help design the electrical system for the limited power and energy of your wind generator?

Reflecting on the Section and the Challenge

Ohm's law expresses the relationship between voltage and current for many resistors. Your appliances are all electrical resistors. These resistors can get hot (in toasters) or help a motor turn (in fans) or create light (in bulbs). Knowing the resistance allows you to use Ohm's law to compute the voltage and current required in a circuit. As you develop your appliance package, you will need to consider the voltage and currents used in the circuit. You may wish to choose appliances that have different resistances to limit the power required in the circuit.



Physics to Go

1. Copy and fill in the table at right that provides two of the following three quantities: voltage drop across a resistor, the current through the resistor, and the resistance of the resistor. As an example, in the first row the resistance is $2\ \Omega$ and the current is $1\ \text{A}$. From $V = IR$, the value of the voltage should be $2\ \text{V}$.

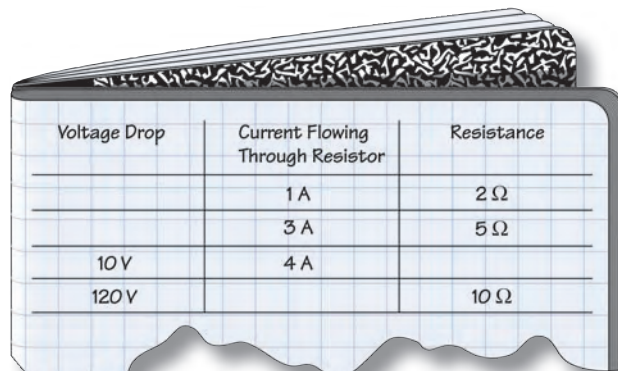

Voltage Drop	Current Flowing Through Resistor	Resistance
	$1\ \text{A}$	$2\ \Omega$
	$3\ \text{A}$	$5\ \Omega$
$10\ \text{V}$	$4\ \text{A}$	
$120\ \text{V}$		$10\ \Omega$

2. A resistor is placed in a circuit. Calculate the resistance in each of the following cases.

- a) The current in the circuit is $3\ \text{A}$ and the voltage drop across the resistor is $12\ \text{V}$.
- b) The current in the circuit is $2\ \text{A}$ and the voltage drop across the resistor is $6\ \text{V}$.

3. A resistor of $5\ \Omega$ is placed in a circuit. The voltage drop across the resistor is $12\ \text{V}$. What is the current through the resistor?

4. A resistor is placed in a circuit. The current in the circuit is $2\ \text{A}$ and the voltage drop across the resistor is $8\ \text{V}$. The voltage is then increased to $12\ \text{V}$. What will be the new current?

5. Active Physics
Plus Using the information in the data table, construct a graph following the directions below.

- Mark an appropriate scale on the x -axis labeled “Current (A).”
- Mark an appropriate scale on the y -axis labeled “Voltage (V).”
- Plot the data points for voltage versus current.
- Draw the best-fit line.

Current (A)	Voltage (V)
0.010	2.3
0.020	5.2
0.030	7.4
0.040	9.9
0.050	12.7

a) Using your graph, find the slope of the best-fit line.

b) What physical quantity does the slope of the graph represent?

6. Your hair dryer has a resistance of $9.6\ \Omega$ and you plug it into the bathroom outlet. Assume household voltage to be $120\ \text{V}$ and that different parts of your house are connected in parallel.

a) What current will it draw?

b) Suppose your brother has an identical hair dryer and plugs it into the same part of the circuit. What current will the two hair dryers draw?

c) If the maximum current the circuit breaker in the system can handle is $20\ \text{A}$, what do you think will happen?



7. **Active Physics** *Plus* Two wires are tested in a lab setting. Current was measured as the voltage across the wire was varied. The results of the experiment are shown in the graph to the right. Both wire A and B obey Ohm's law. Which wire has the greatest resistance?

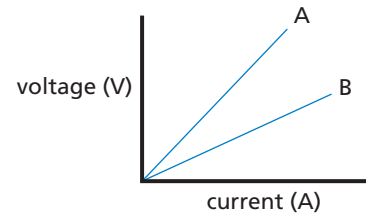

8. A 12-V battery is hooked up to a 3- Ω resistor. The current through the resistor is
 a) 36 A b) 12 A c) 4 A d) $\frac{1}{4}$ A
9. A 2- Ω resistor has 4 A of current running through it. The voltage drop (or potential drop) across the resistor is
 a) $\frac{1}{2}$ V b) 2 V c) 4 V d) 8 V

Inquiring Further

Write ohm (home) about it

The ohm is a unit of electrical resistance and is given the symbol Ω , the Greek letter *omega*. You can have some fun with the ohm by creating an “ohm-expression.” A few examples are given below. Try to develop one of your own “ Ω -expressions.”

