

A decorative graphic consisting of a horizontal blue line extending from the left edge, a vertical blue line extending from the top edge, and another horizontal blue line extending from the right edge. Small white circles with blue outlines are positioned at the intersections of these lines: one at the top-left corner and one at the bottom-right corner.

Cladistics

Kingdom Summary

1. Two Kingdom Classification (Carolus Linnaeus, 1758)

- Kingdom: Plantae (All plants)
- Kingdom: Animalia (All animals)

2. Three Kingdom Classification (Ernst Haeckel, 1866)

- Kingdom: Protista (Unicellular organisms)
- Kingdom: Plantae (Multicellular plants)
- Kingdom: Animalia (Multicellular animals)

3. Four Kingdom Classification (Copeland, 1966)

- Kingdom: Monera (Prokaryotic organisms)
- Kingdom: Protista (Primitive eukaryotes)
- Kingdom: Metaphyta (Advanced eukaryotic plants)
- Kingdom: Metazoa (Advanced eukaryotic animals)

4. Five Kingdom Classification (Whittaker R.H., 1969)

- Kingdom: Monera
- Kingdom: Protista
- Kingdom: Mycota (Exclusively for fungi)
- Kingdom: Metaphyta
- Kingdom: Metazoa

Review slide

Classification

■ Old 5 Kingdom system

- Monera, Protists, Plants, Fungi, Animals

■ New 3 Domain system

- ◆ reflects a greater understanding of evolution & molecular evidence

- Prokaryote: Bacteria
- Prokaryote: Archaeobacteria
- Eukaryotes
 - ◆ Protists
 - ◆ Plants
 - ◆ Fungi
 - ◆ Animals

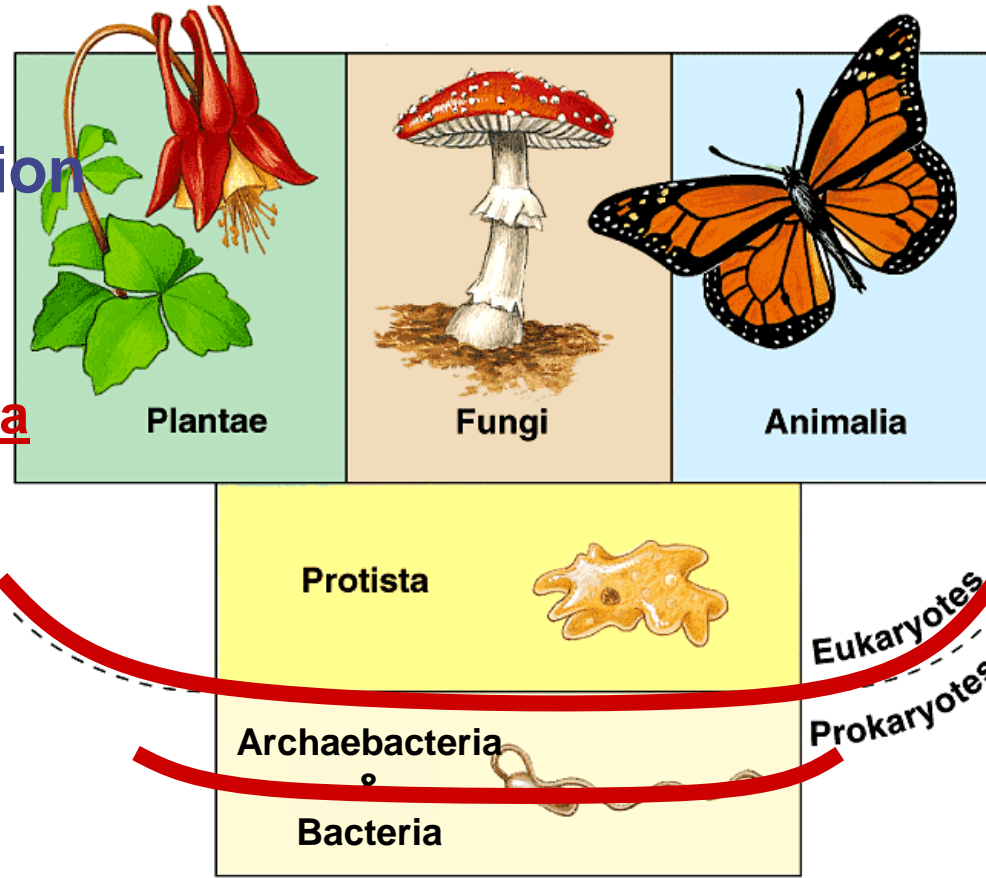
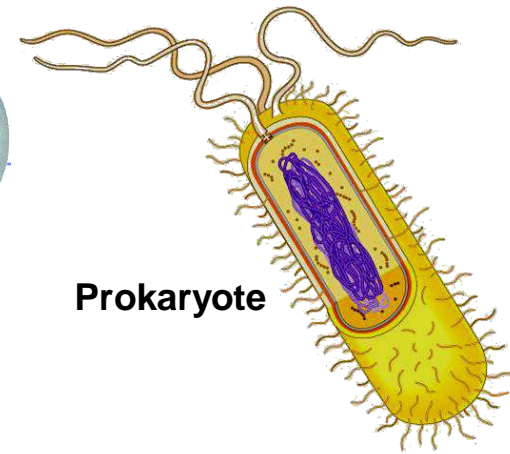
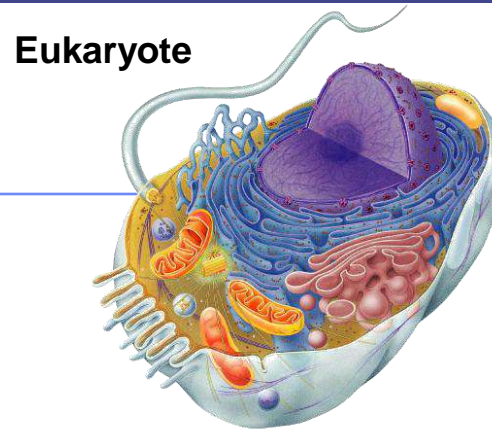

Classification

- Traditional vs
- ◆ (phenetics)
- ◆ Structural data

Phylogenetics

(cladistics)

all data: structural, fossil, biochem, etc

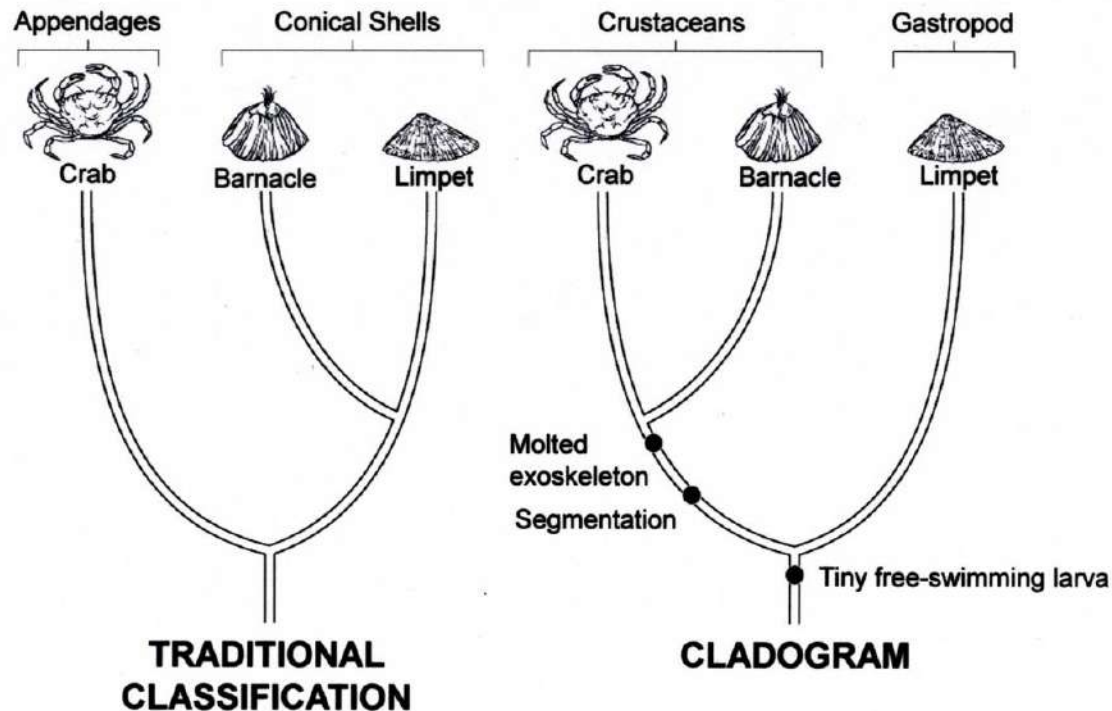

Cladograms & Phylogenetic Trees

- hypotheses about evolutionary relationships
- based on all available evidence
- test by looking for further evidence to support/refute
- rework if dictated by new evidence

Evidence for Cladistics

- ◆ Comparative anatomy
- ◆ Cell structure
- ◆ Comparative embryology
- ◆ Molecular evidence
- ◆ Biochemistry
- ◆ Physiology
- ◆ Behavior
- ◆ Geography
- ◆ Ecology
- ◆ Fossils

Clade or Taxon

- **group of organisms that share common feature**
- **must include ancestor & all descendants**

Understanding phylogenies

- Understanding a phylogeny is a lot like reading a family tree. The root of the tree represents the ancestral lineage, and the tips of the branches represent the descendants of that ancestor. As you move from the root to the tips, you are moving forward in time.

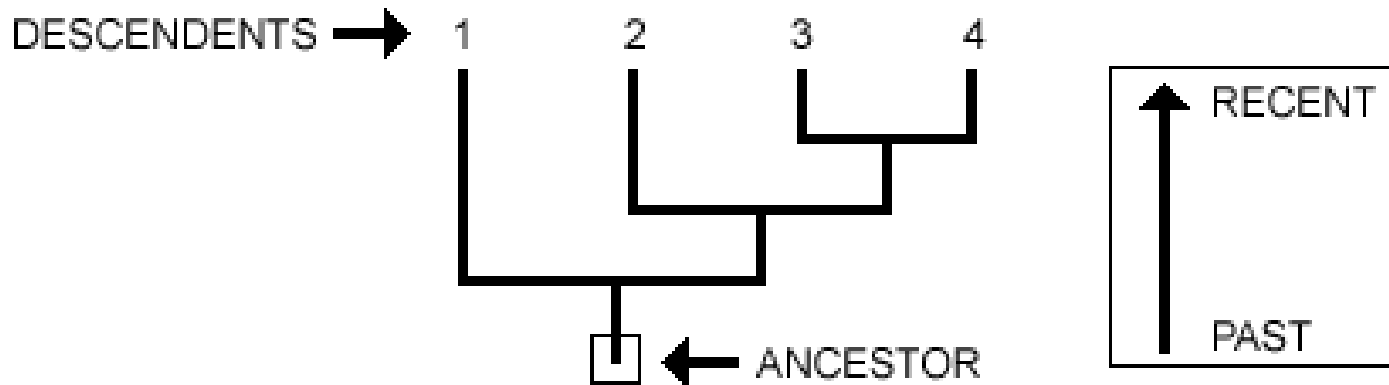

Understanding phylogenies

- When a lineage splits (speciation), it is represented as branching on a phylogeny. When a speciation event occurs, a single ancestral lineage gives rise to two or more daughter lineages.

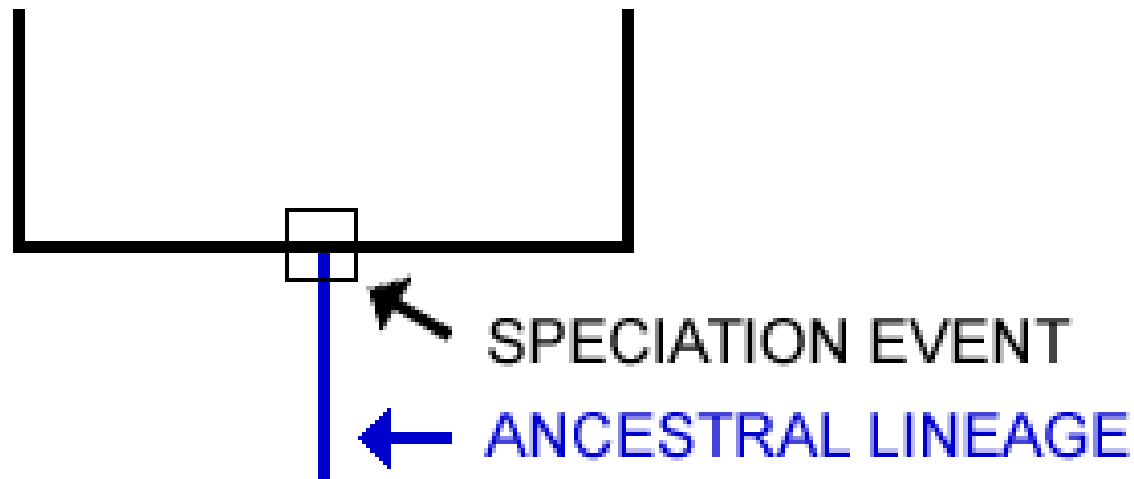

Understanding phylogenies

- Phylogenies trace patterns of shared ancestry between lineages. Each lineage has a part of its history that is unique to it alone and parts that are shared with other lineages.

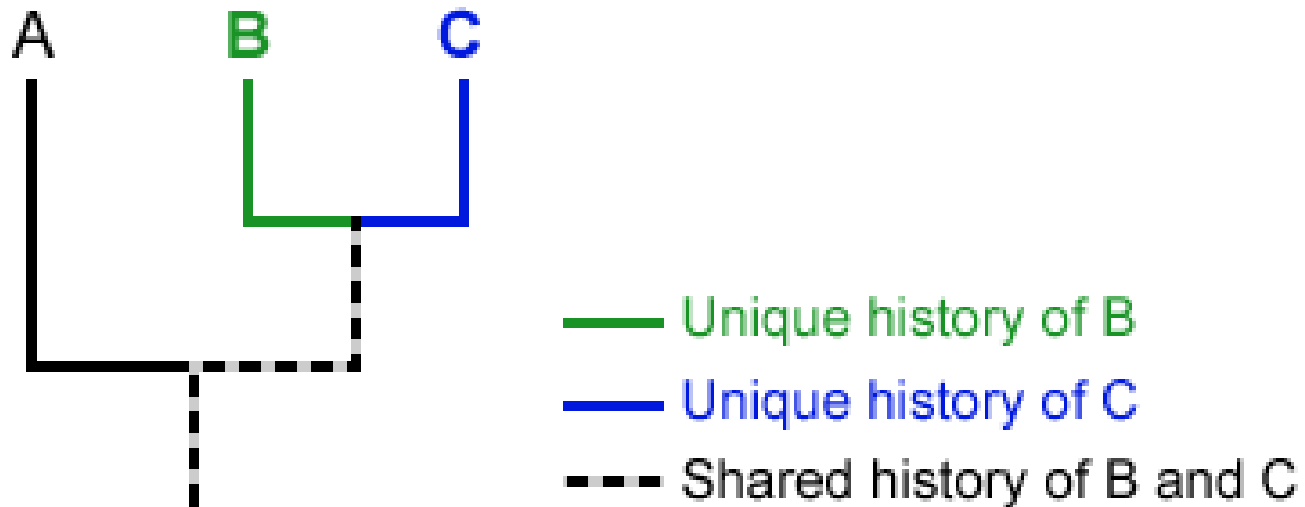

Understanding phylogenies

- Similarly, each lineage has ancestors that are unique to that lineage and ancestors that are shared with other lineages — common ancestors.

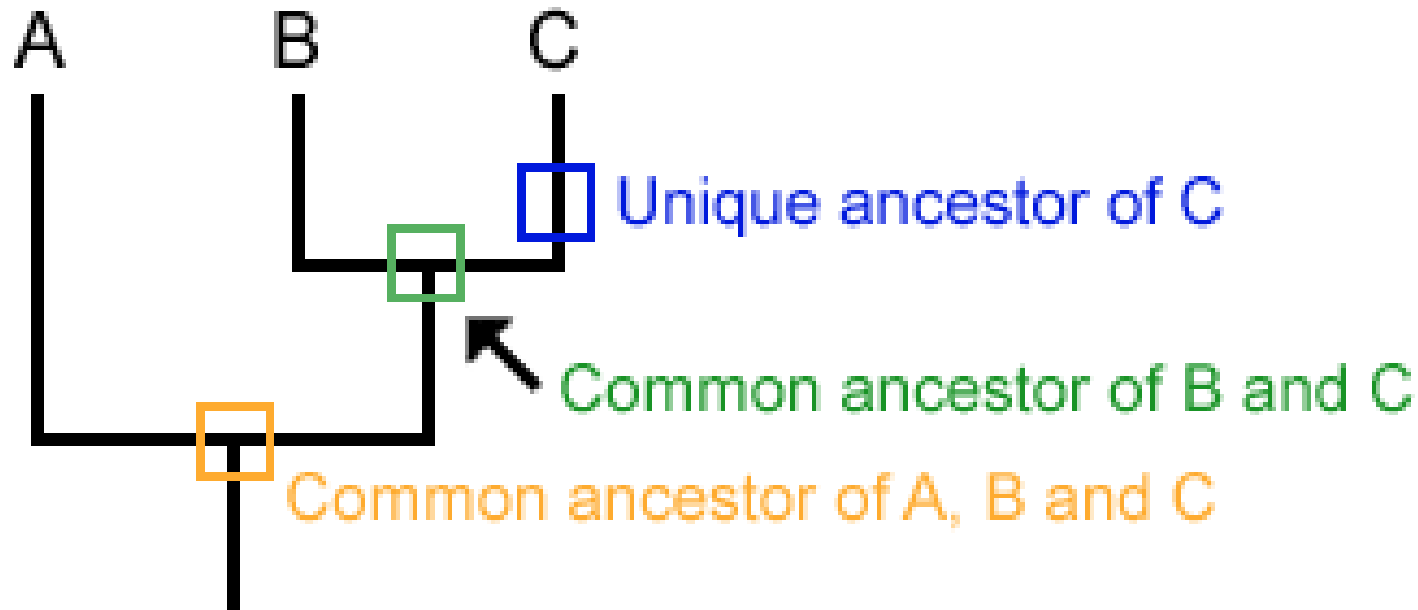

Clades

- A clade is a grouping that includes a common ancestor and all the descendants (living and extinct) of that ancestor. Using a phylogeny, it is easy to tell if a group of lineages forms a clade. Imagine clipping a single branch off the phylogeny — all of the organisms on that pruned branch make up a clade

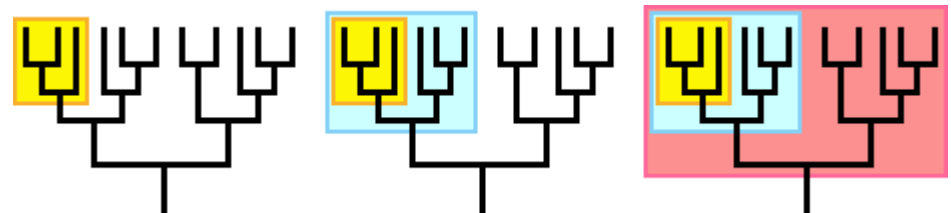
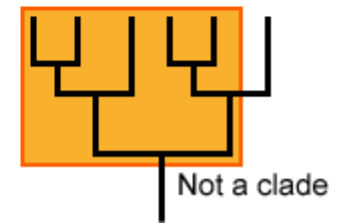
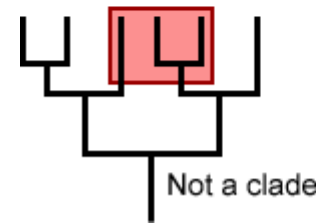
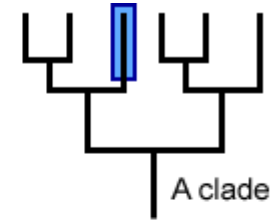
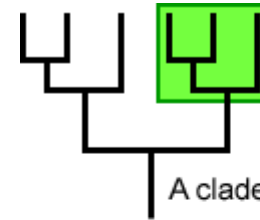

Cladograms

- **Distinguish between ancestral & derived traits**
 - **ancestral**
 - **shared with common ancestor**
 - **derived**
 - **new to a clade**
 - **differentiates that clade from its ancestors**
- **Apply principle of parsimony**
 - **assume simplest hypothesis most likely correct**

Cladogram of Vertebrates

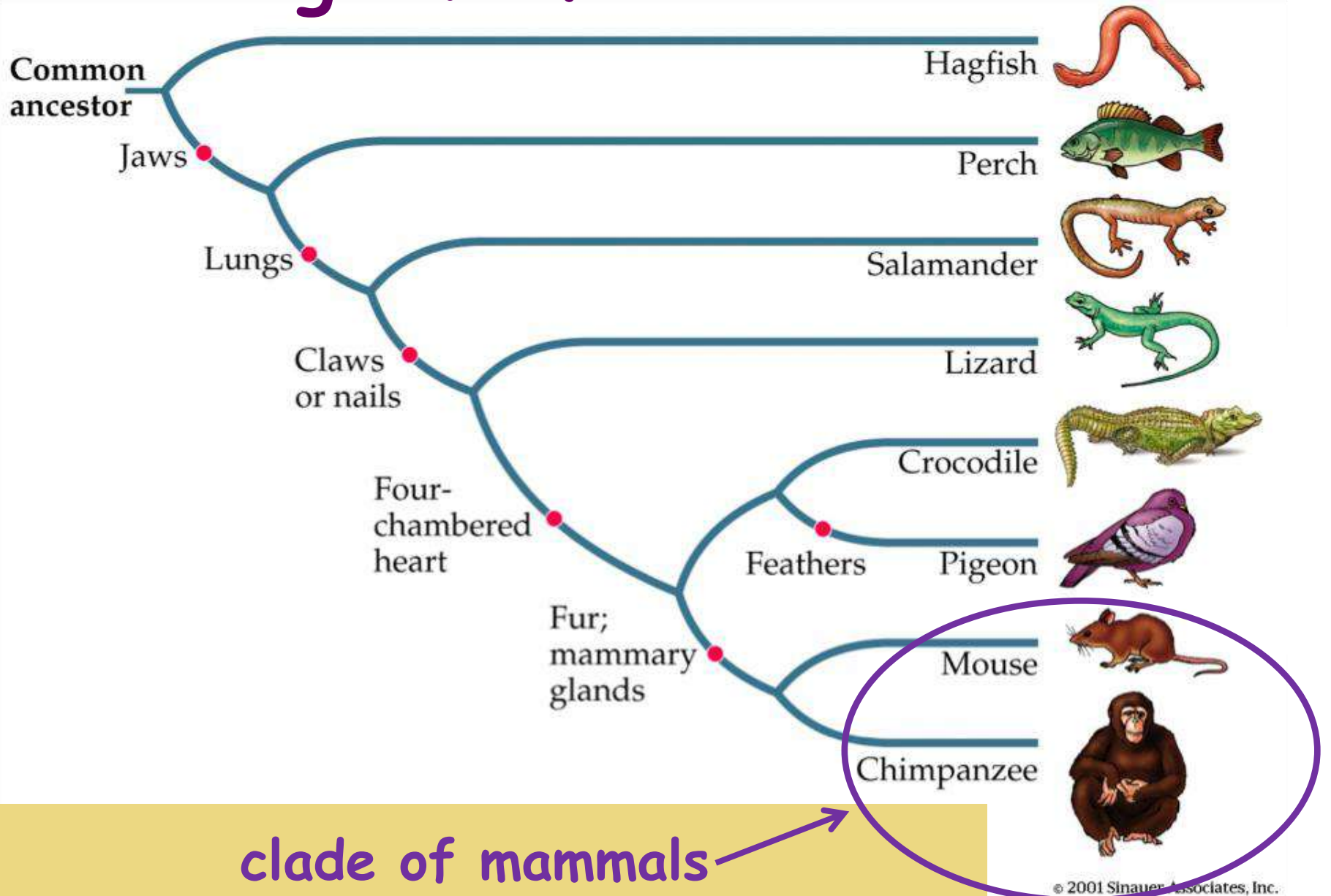

clade of mammals

How to read a phylogenetic tree

(A)

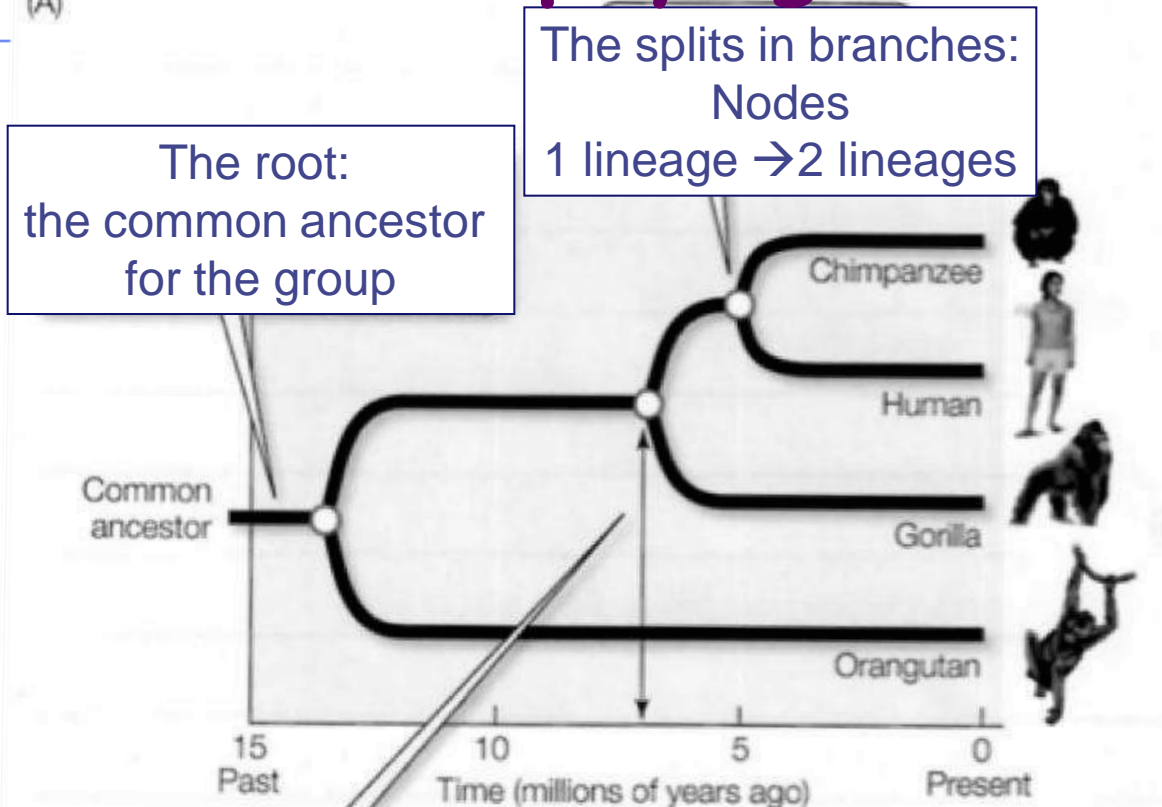

The root:
the common ancestor
for the group

The splits in branches:
Nodes
1 lineage → 2 lineages

Positions of nodes
on time scale (if present)
indicate times
of corresponding
speciation events

How to read a phylogenetic tree

Branches can be rotated around any node without changing the meaning of the tree

(B)

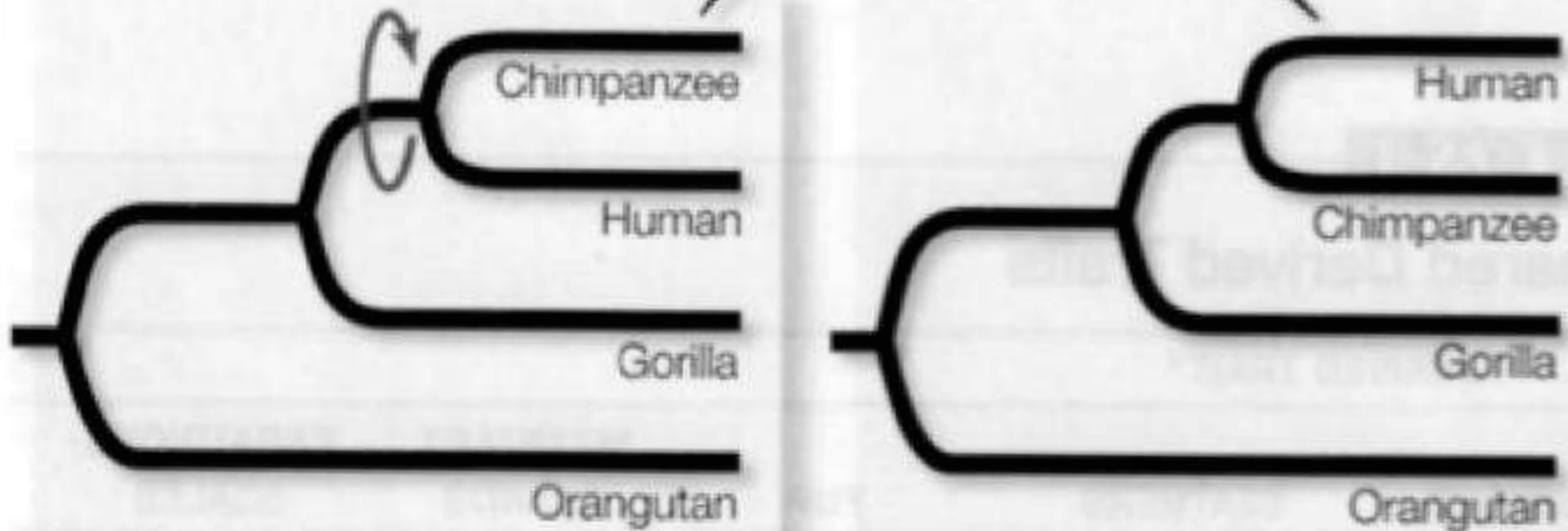

Which phylogenetic tree is accurate?

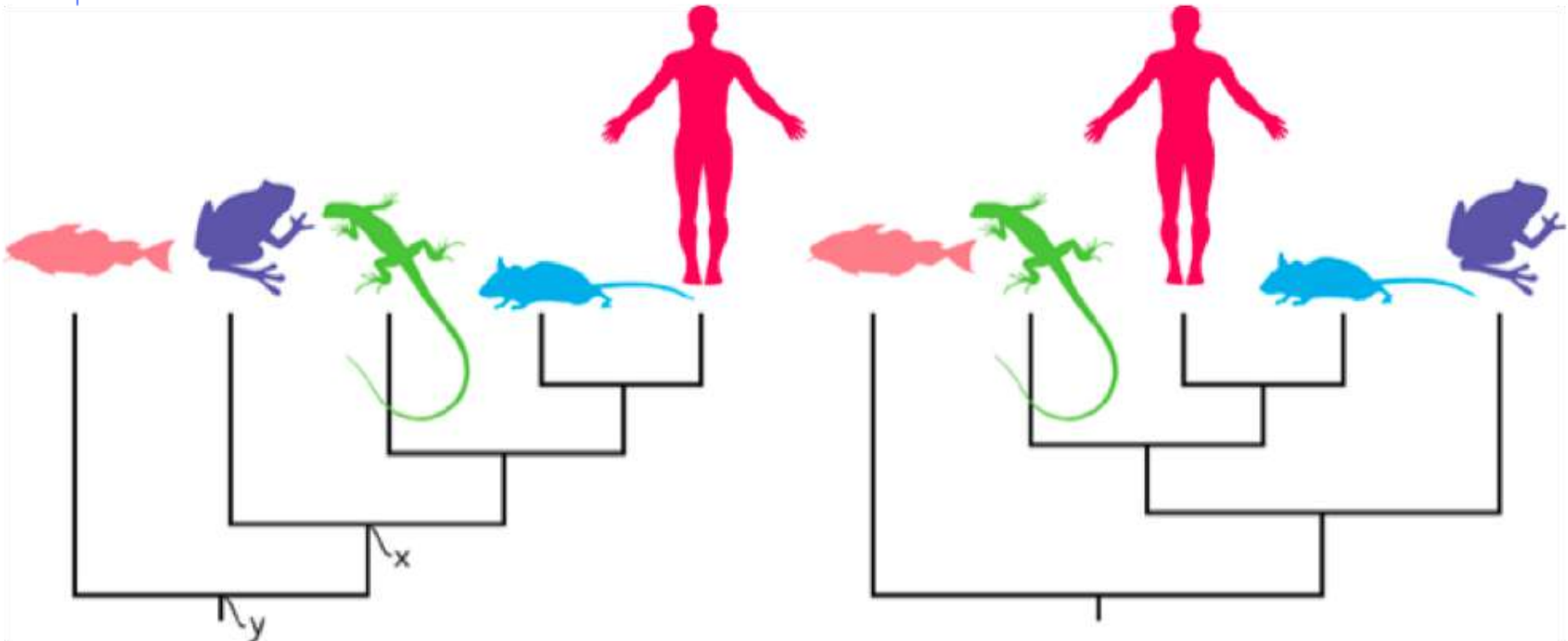

Which phylogenetic tree is accurate?

Trees are identical.

Note: Rotation around node x does not affect meaning of tree.

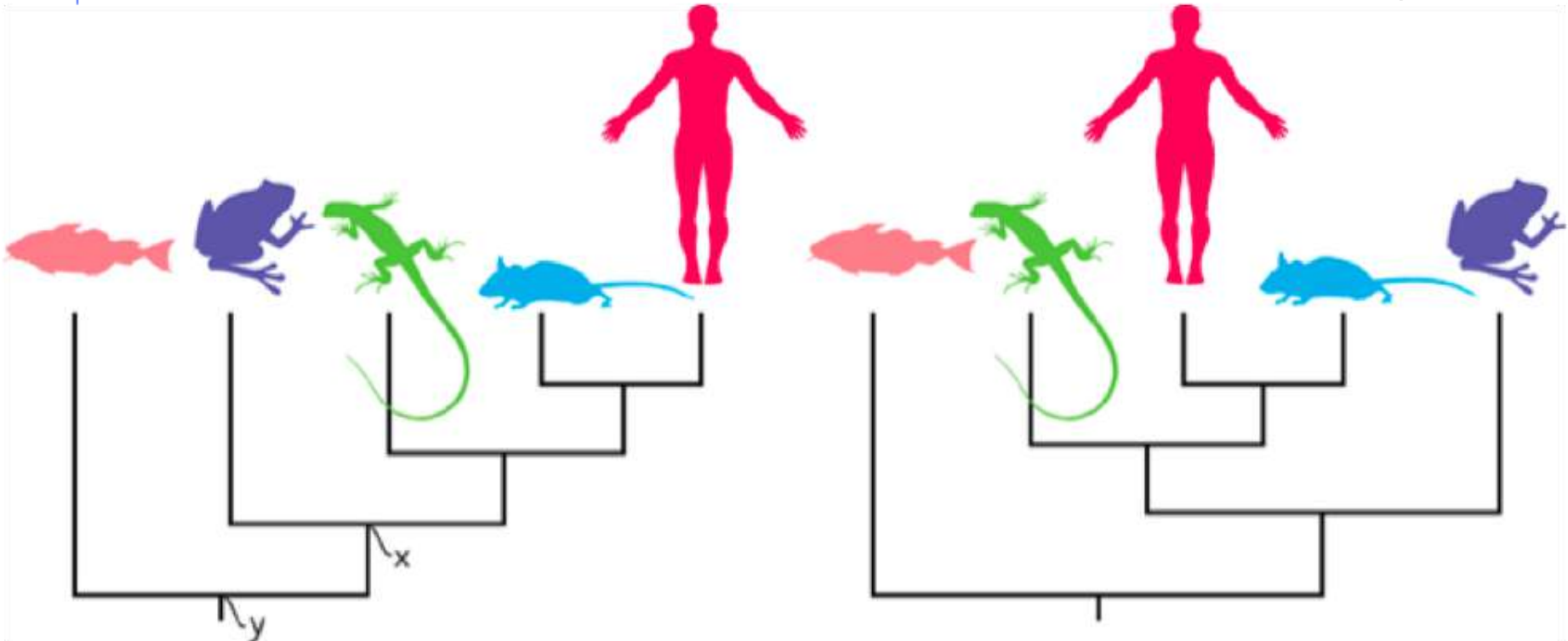

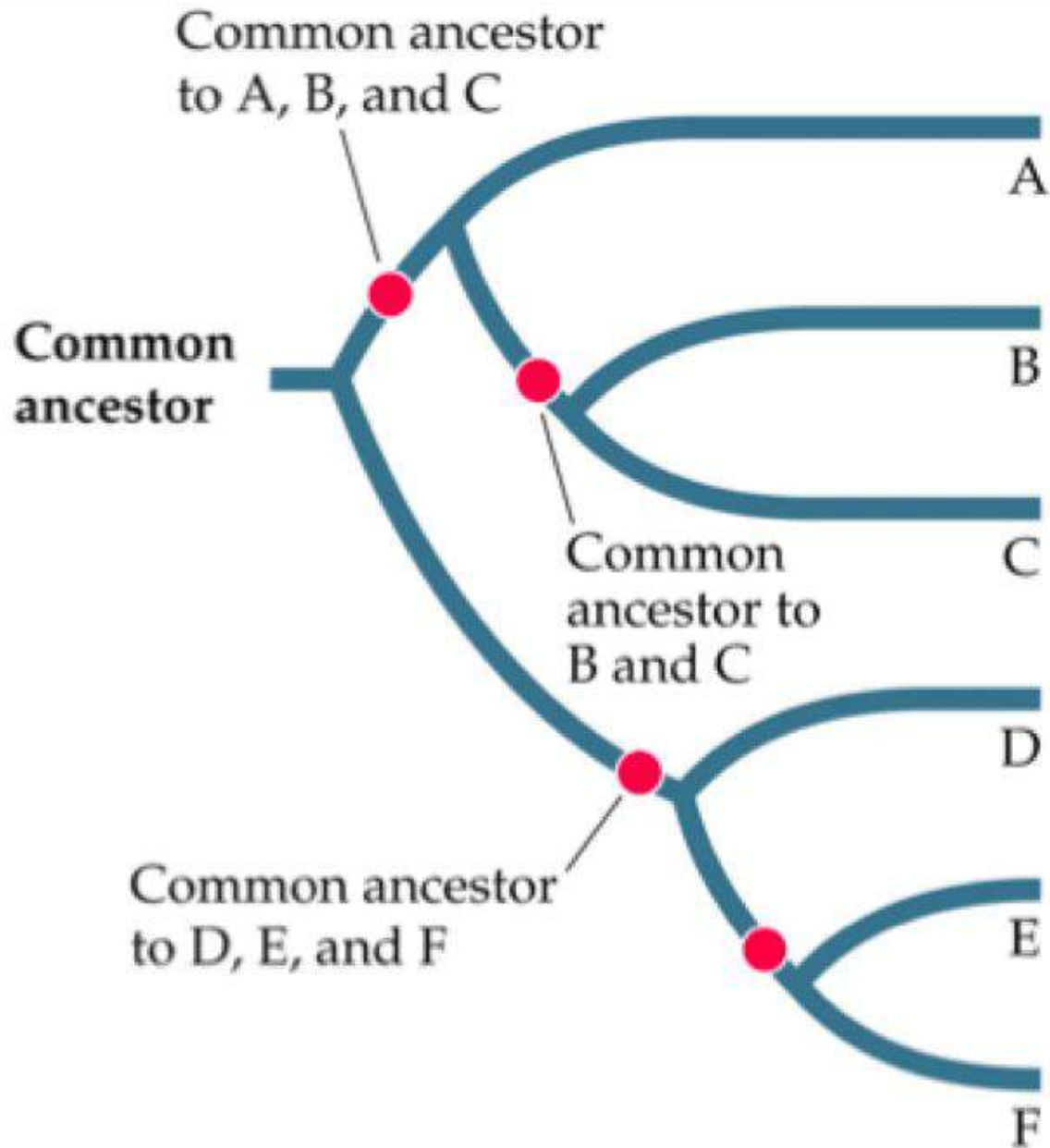

D is equally related to E and F.

Eight Vertebrates Ordered According to Unique Shared Derived Traits

TAXON	DERIVED TRAIT ^a							
	JAWS	LUNGS	CLAWS OR NAILS	GIZZARD	FEATHERS	FUR	MAMMARY GLANDS	KERATINOUS SCALES
Lamprey (outgroup)	-	-	-	-	-	-	-	-
Perch	+	-	-	-	-	-	-	-
Salamander	+	+	-	-	-	-	-	-
Lizard	+	+	+	-	-	-	-	+
Crocodile	+	+	+	+	-	-	-	+
Pigeon	+	+	+	+	+	-	-	+
Mouse	+	+	+	-	-	+	+	-
Chimpanzee	+	+	+	-	-	+	+	-

^aA plus sign indicates the trait is present, a minus sign that it is absent.

Use to construct a cladogram.
Start with a trait that all organisms share

The outgroup branches off before the basal node of the ingroup.

Common ancestor

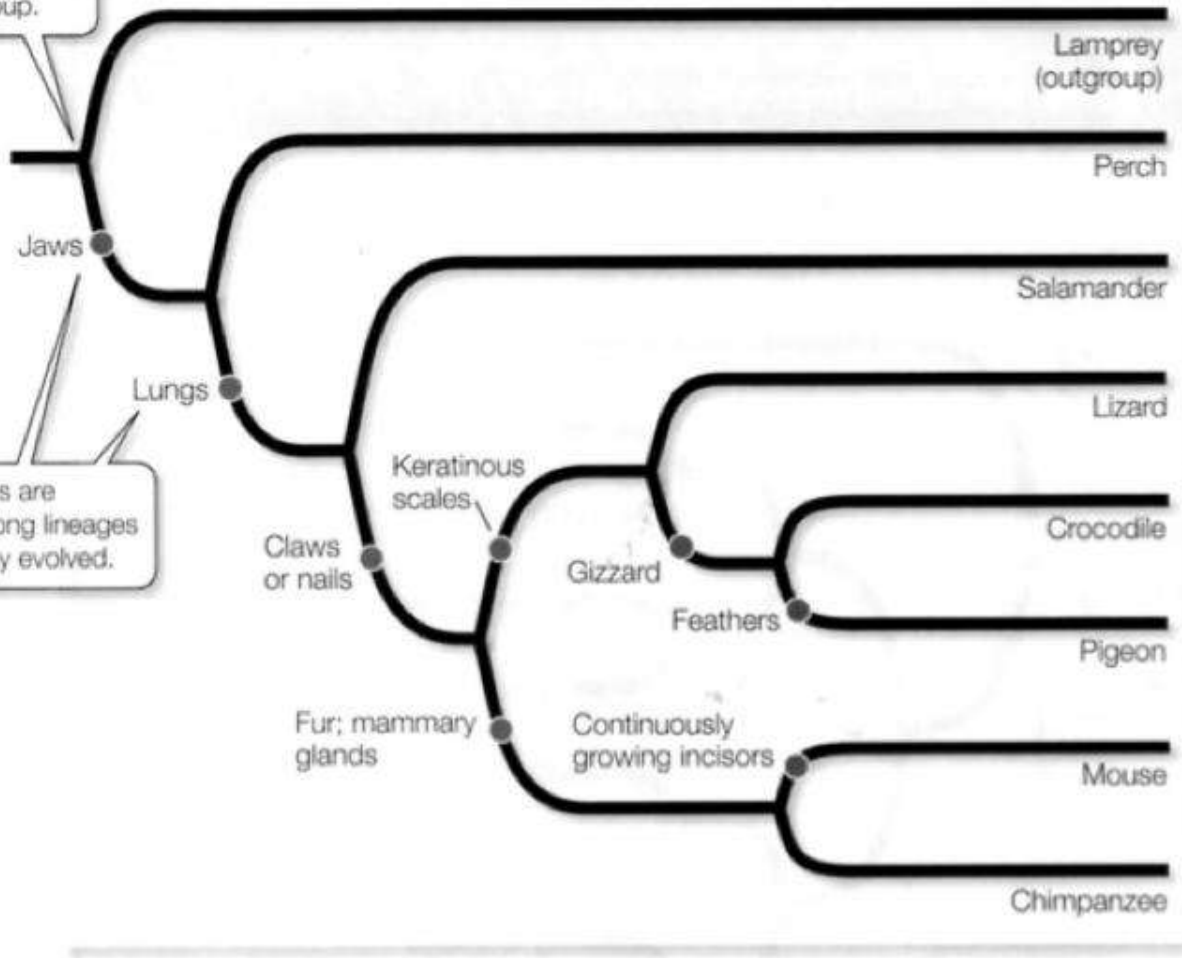

Derived traits are indicated along lineages in which they evolved.

The lamprey is designated as the outgroup.



Ingroup

Nodes indicate traits that “define” a new branch of the tree.

Extinction

- This phylogeny represents vertebrate evolution. The lengths of the branches have been adjusted to show when lineages split and went extinct.

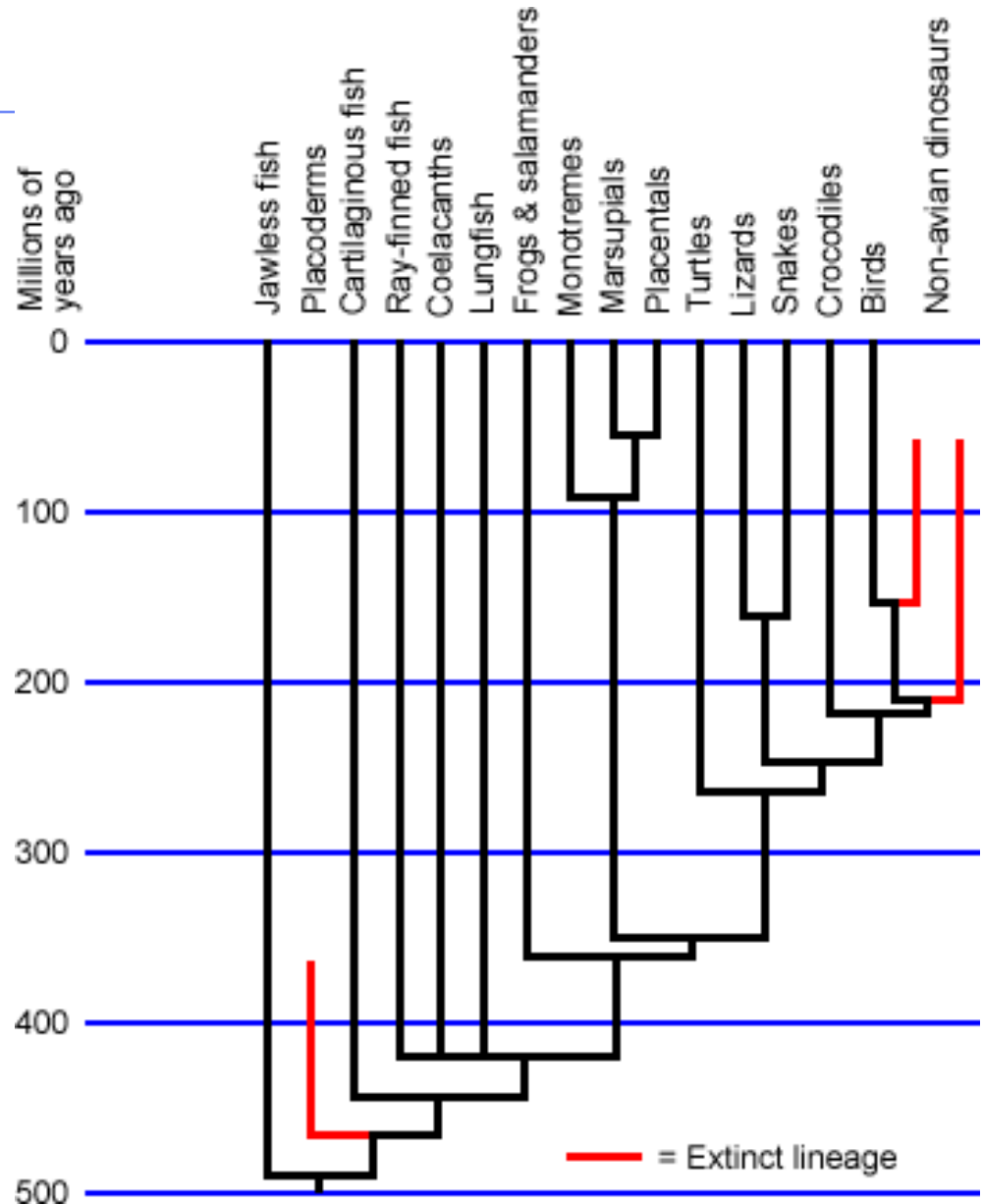

1. Name an ancestral trait of mammals.

- Name a derived trait of mammals.

CHARACTERS	TAXA					
	Lancelet (outgroup)	Lamprey	Tuna	Salamander	Turtle	Leopard
Hair	0	0	0	0	0	1
Amniotic (shelled) egg	0	0	0	0	1	1
Four walking legs	0	0	0	1	1	1
Hinged jaws	0	0	1	1	1	1
Vertebral column (backbone)	0	1	1	1	1	1

(a) Character table

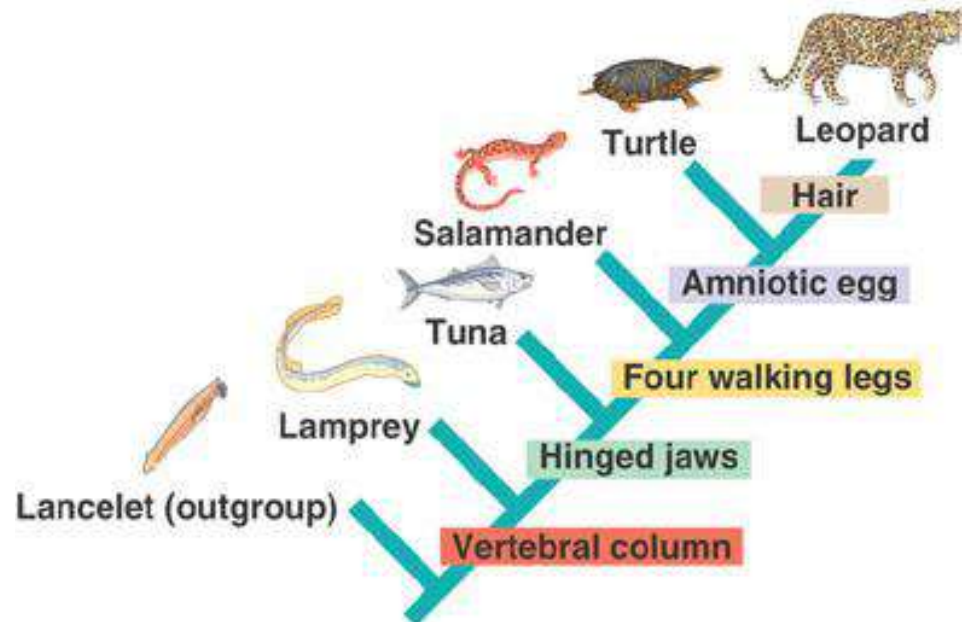

A CLADE MUST BE MONOPHYLETIC

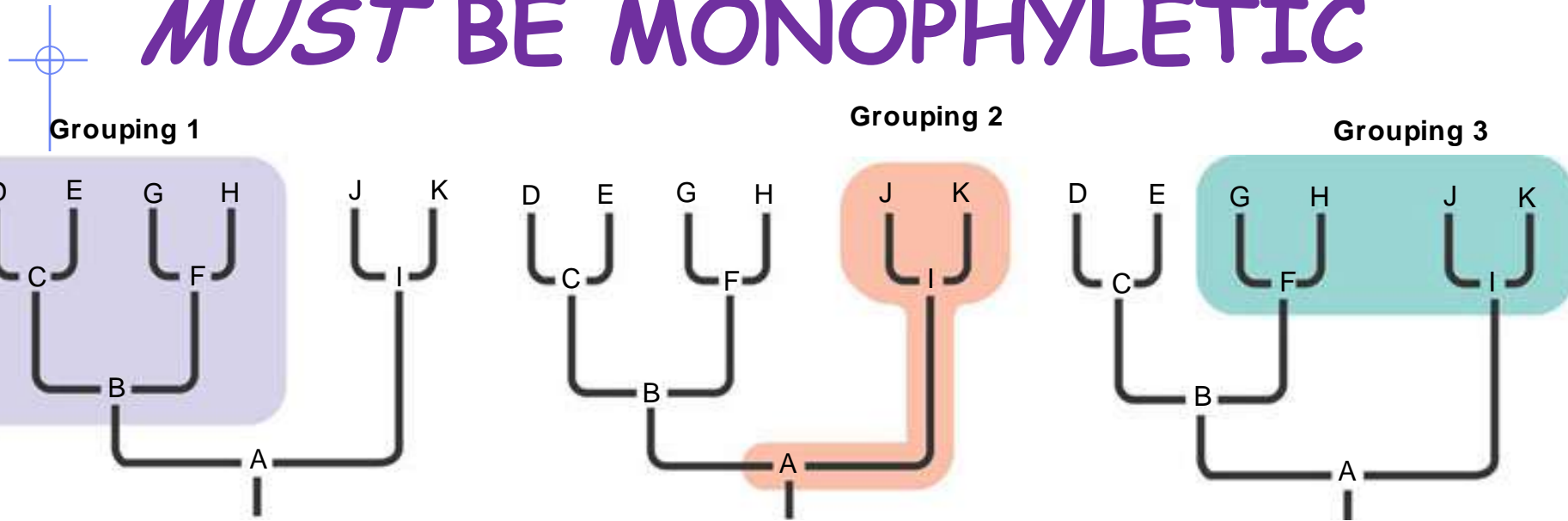

- **Monophyletic group**

- includes ancestor & all descendants
- “single tribe”

Which grouping is monophyletic?

A CLADE MUST BE MONOPHYLETIC

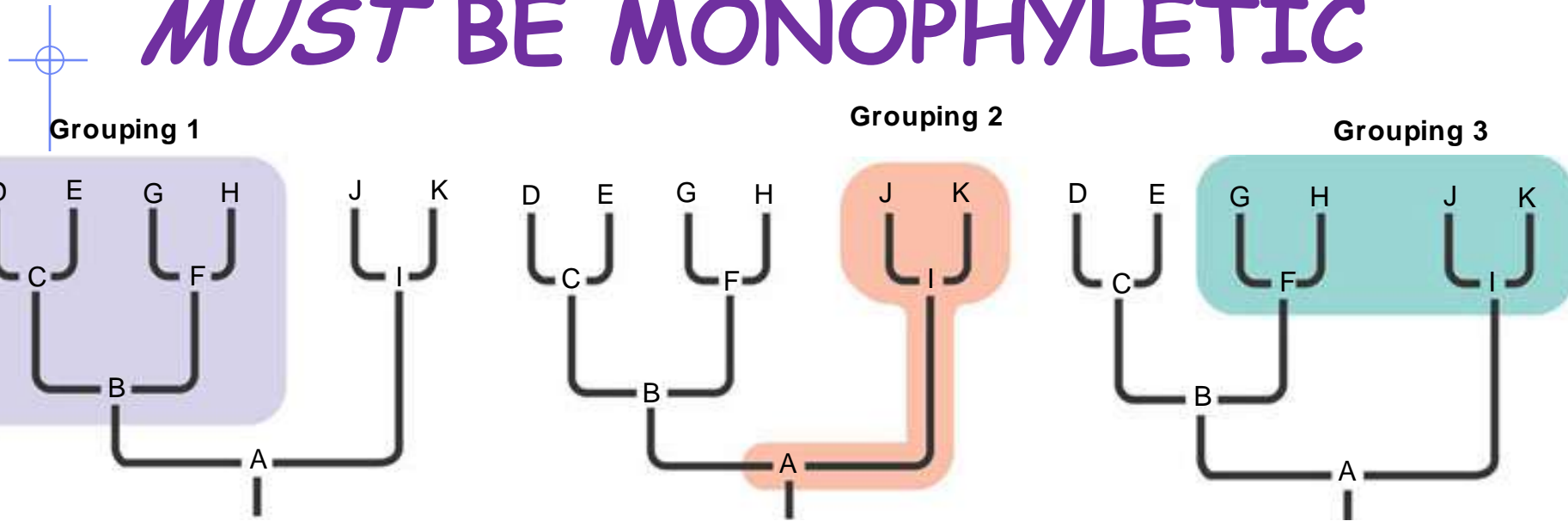

- **Monophyletic group**

- includes ancestor & all descendants
- “single tribe”

Which grouping is monophyletic?

Grouping 1

Monophyletic

- includes ancestor & all descendants

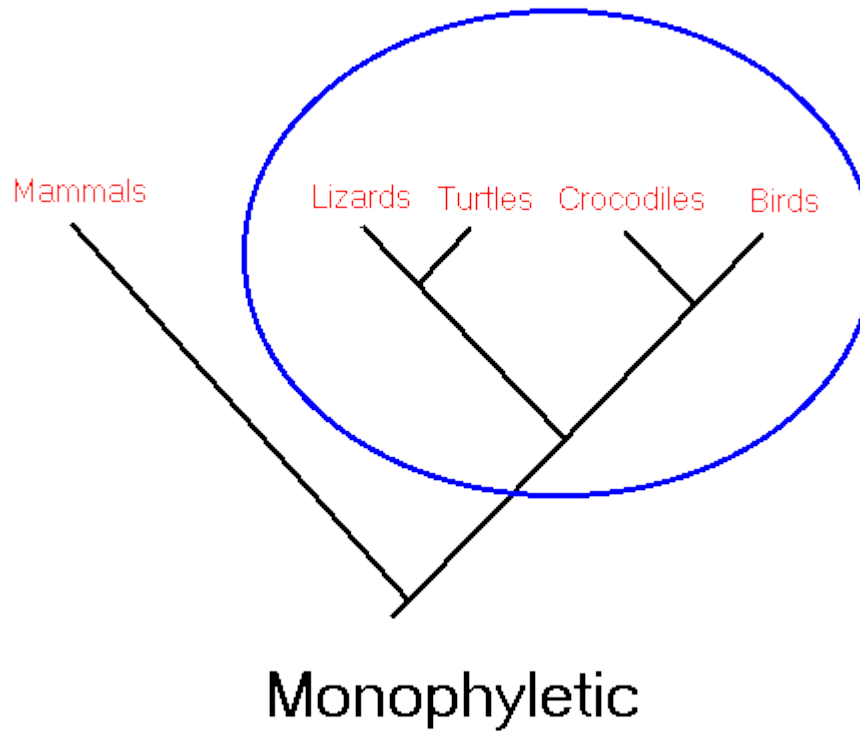

PARAPHYLETIC GROUP is *NOT* A CLADE

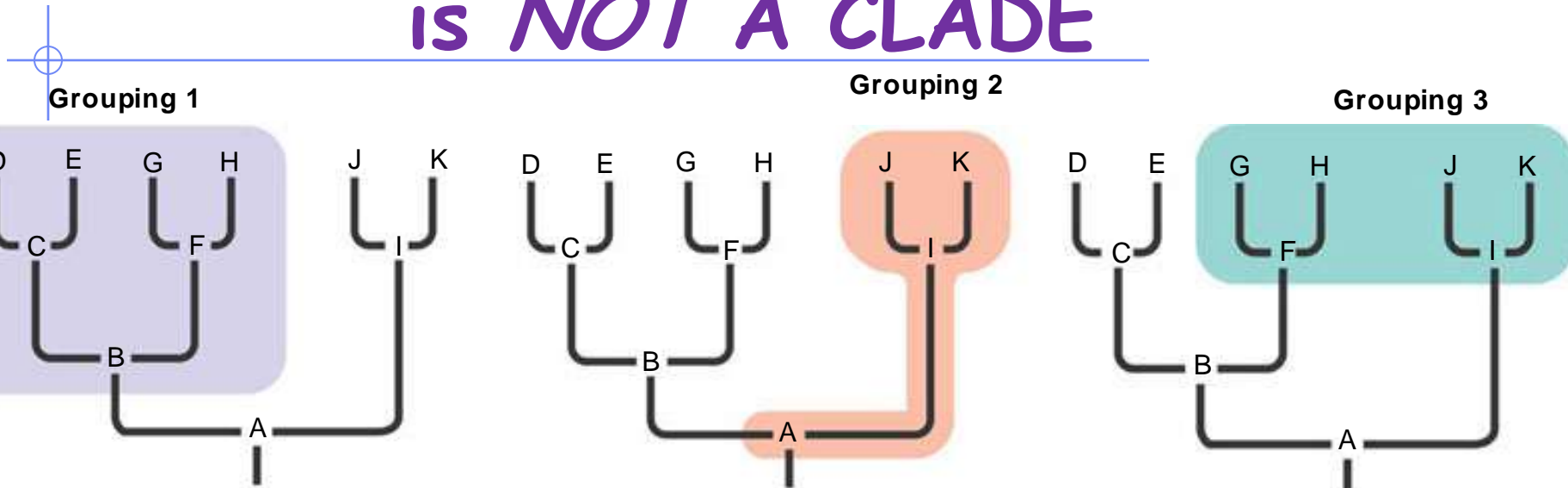

• Paraphyletic group

- ancestral species & some (not ALL) descendants
- “beside the tribe”

Which grouping is paraphyletic?

PARAPHYLETIC GROUP is *NOT* A CLADE

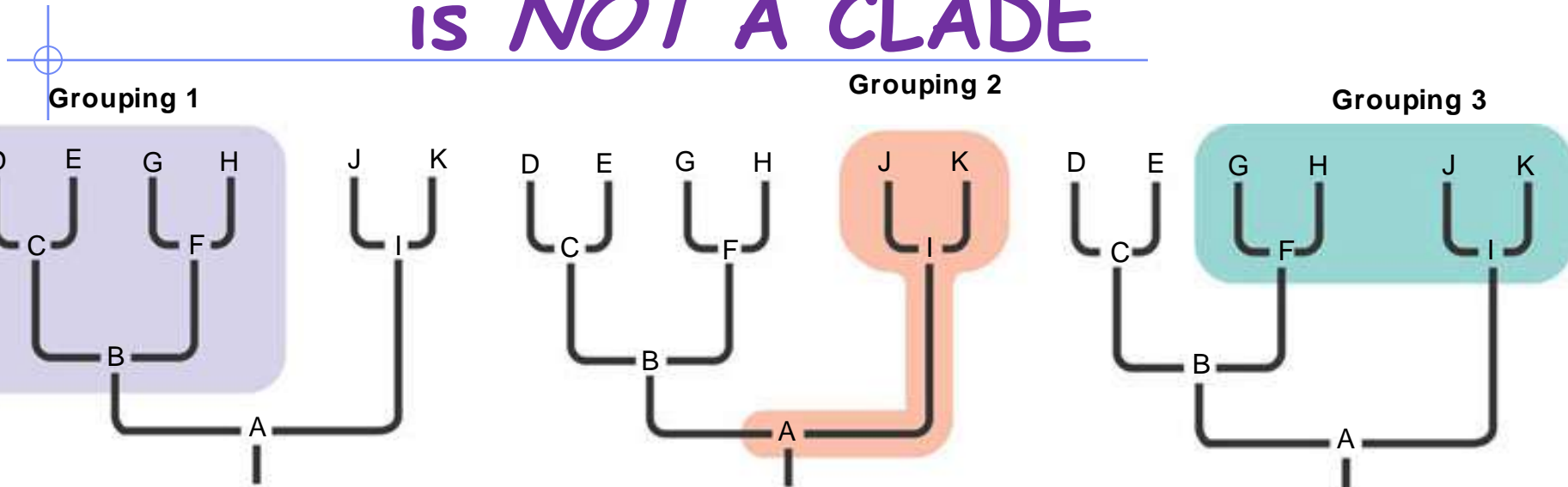

• Paraphyletic group

- ancestral species & some (not ALL) descendants
- “beside the tribe”

Which grouping is paraphyletic?

Grouping 2

POLYPHYLETIC GROUP is *NOT* A CLADE

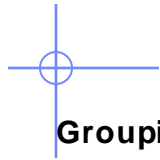

Grouping 1

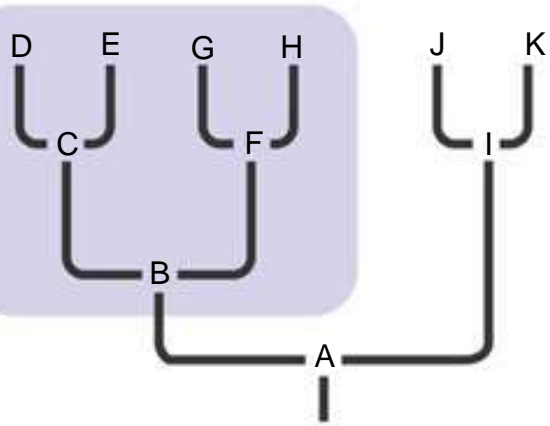

Grouping 2

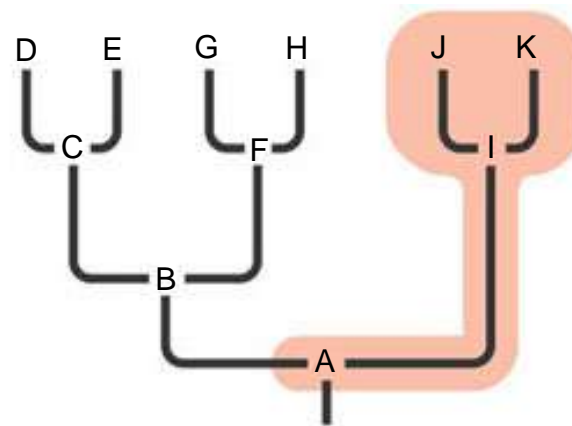

Grouping 3

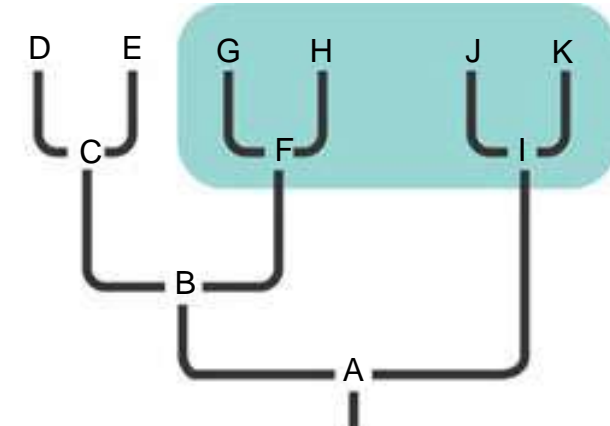

• polyphyletic group

- descendants of > one common ancestor
- “many tribes”

Which grouping is polyphyletic?

Grouping 3

Taxa

- **Taxon (pl. taxa) = any group of organisms that is given a formal taxonomic name.**
 - ◆ **monophyletic taxon** = includes the most recent common ancestor of a group of organisms, *and all of its descendents* [as in (a)].
 - ◆ **polyphyletic taxon** = *does not include the common ancestor of all members of the taxon* [as in (b)].
 - ◆ **paraphyletic taxon** = includes the most recent common ancestor, *but not all of its descendents* [as in (c)].

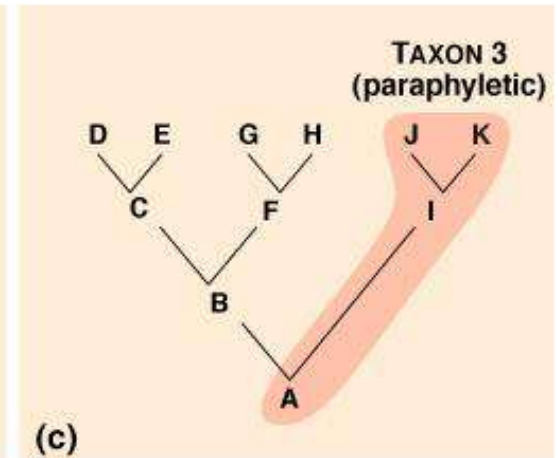
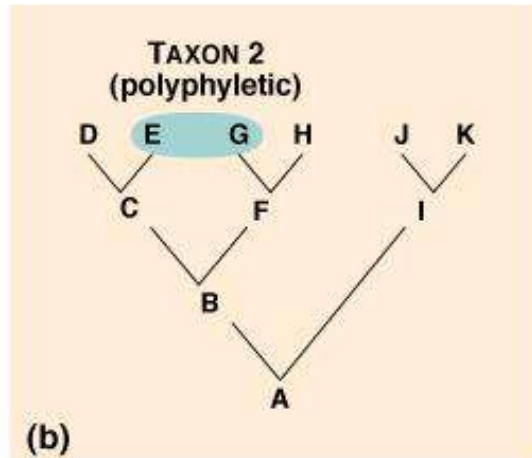
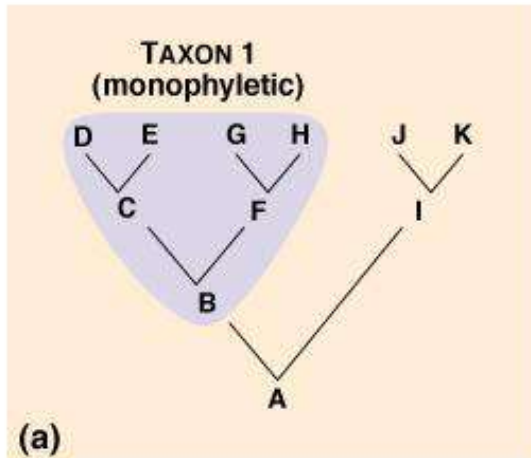

Taxa



Taxa in modern classifications are expected to be monophyletic groups.

Paraphyletic and polyphyletic groups are not considered appropriate taxonomic units.

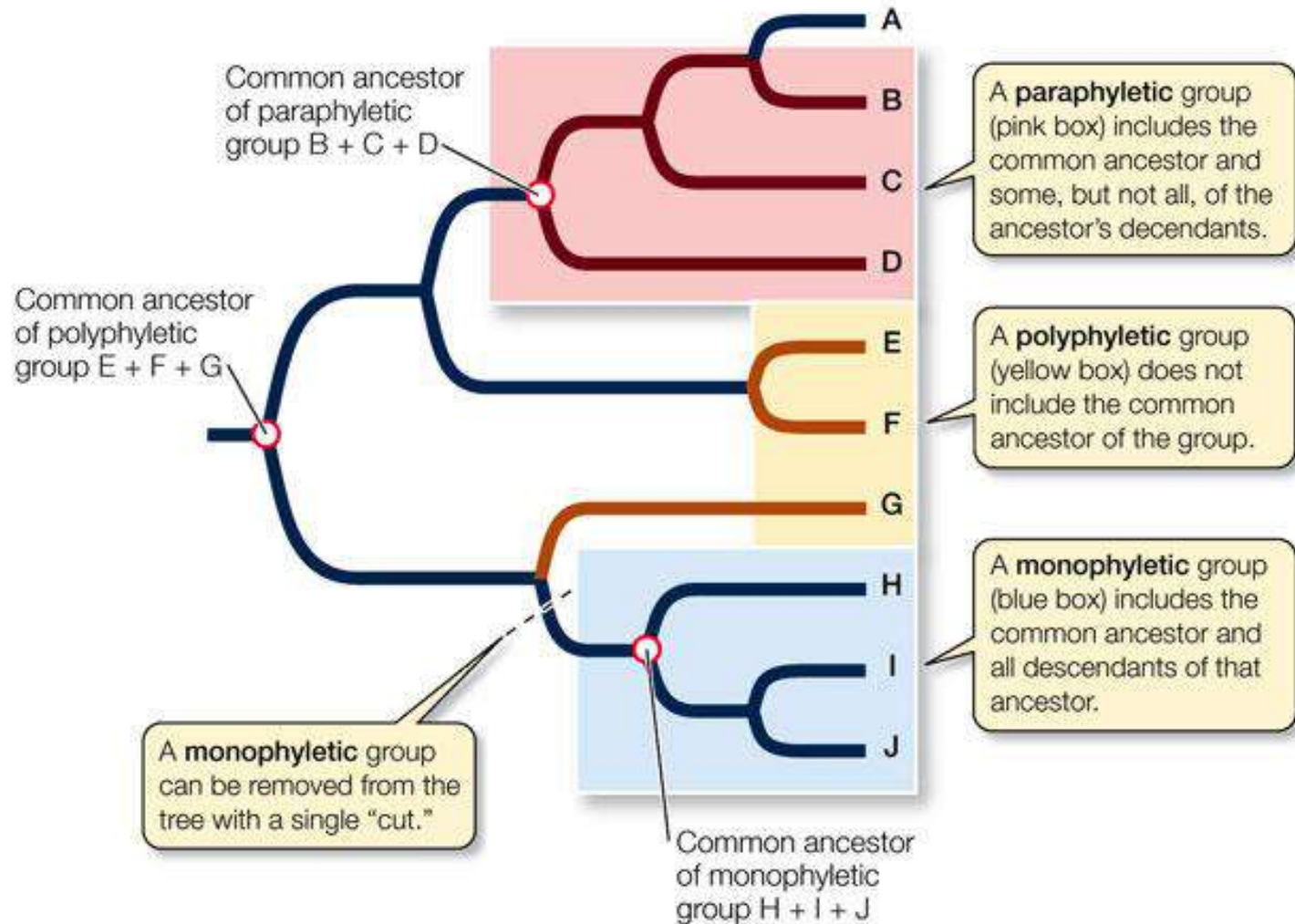

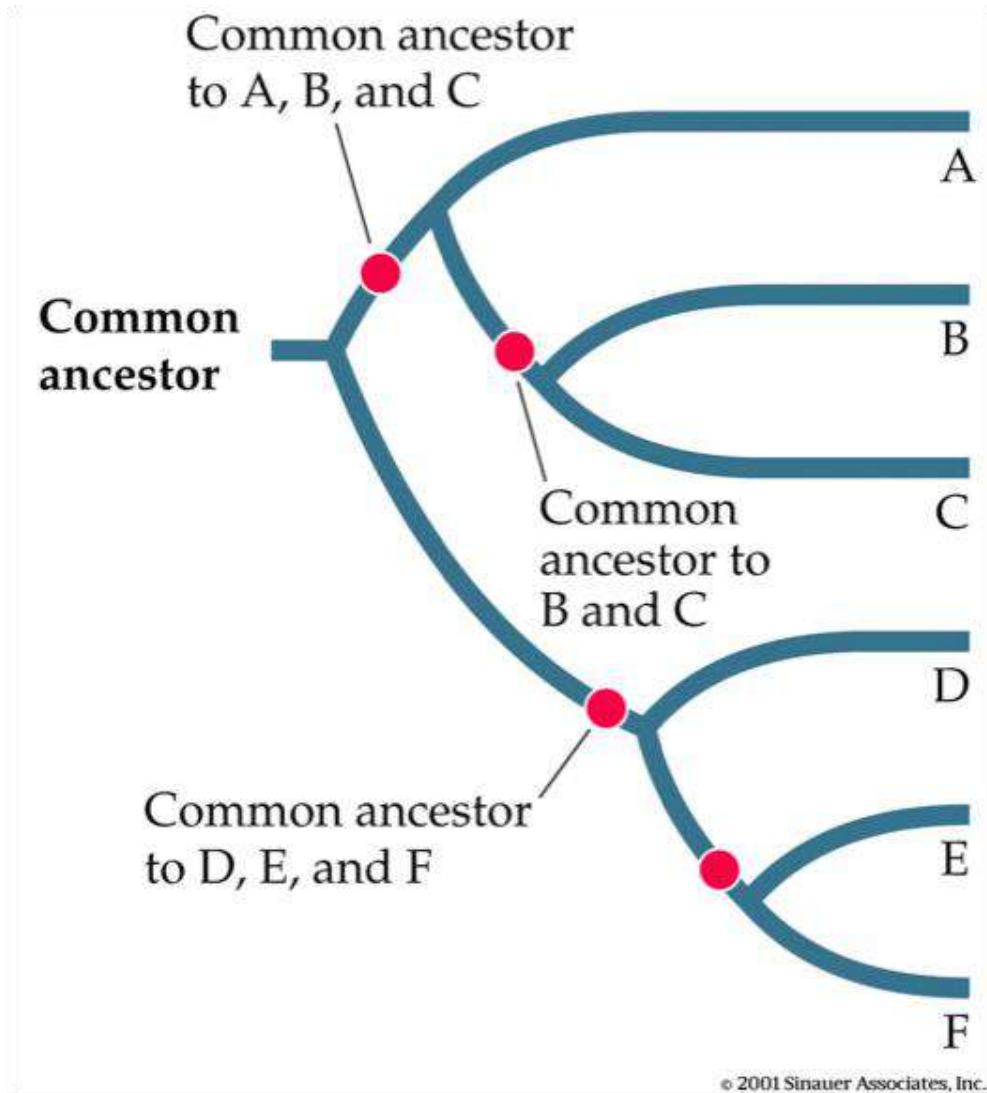

Tip:
Monophyletic group
can be obtained by
making a **single cut**
in the tree.

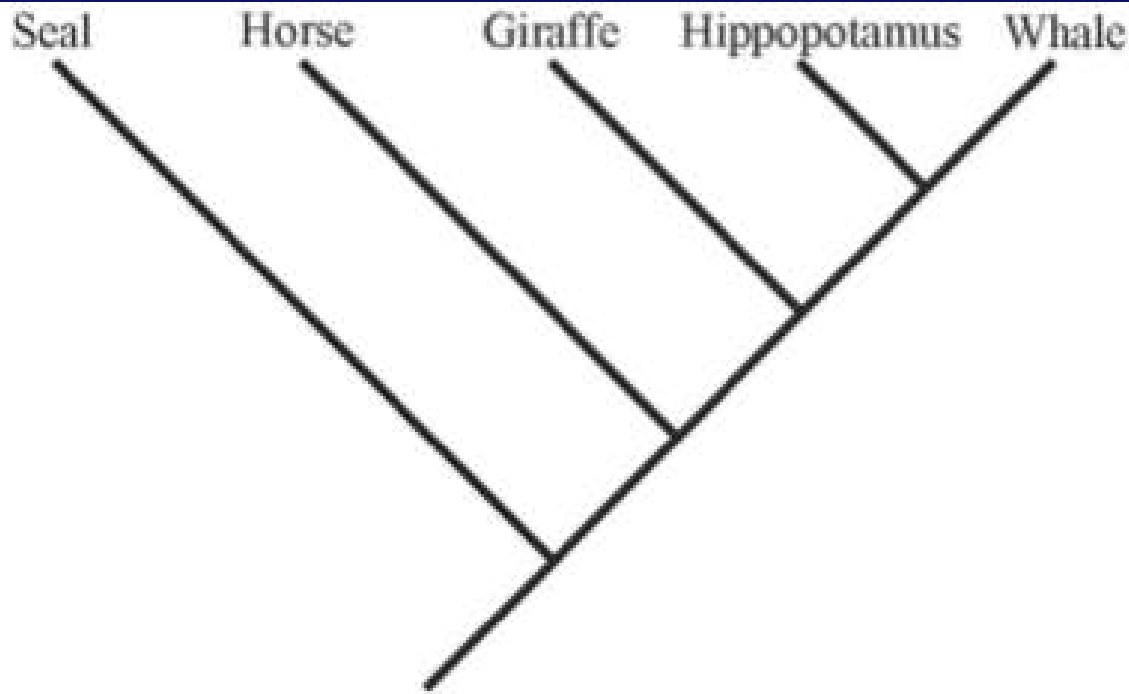

1. By reference to the tree above, which of the following is an accurate statement of relationships? *Explain your answer.*

- a) A seal is more closely related to a horse than to a whale
- b) A seal is more closely related to a whale than to a horse
- c) A seal is equally related to a horse and a whale
- d) A seal is related to a whale, but is not related to a horse

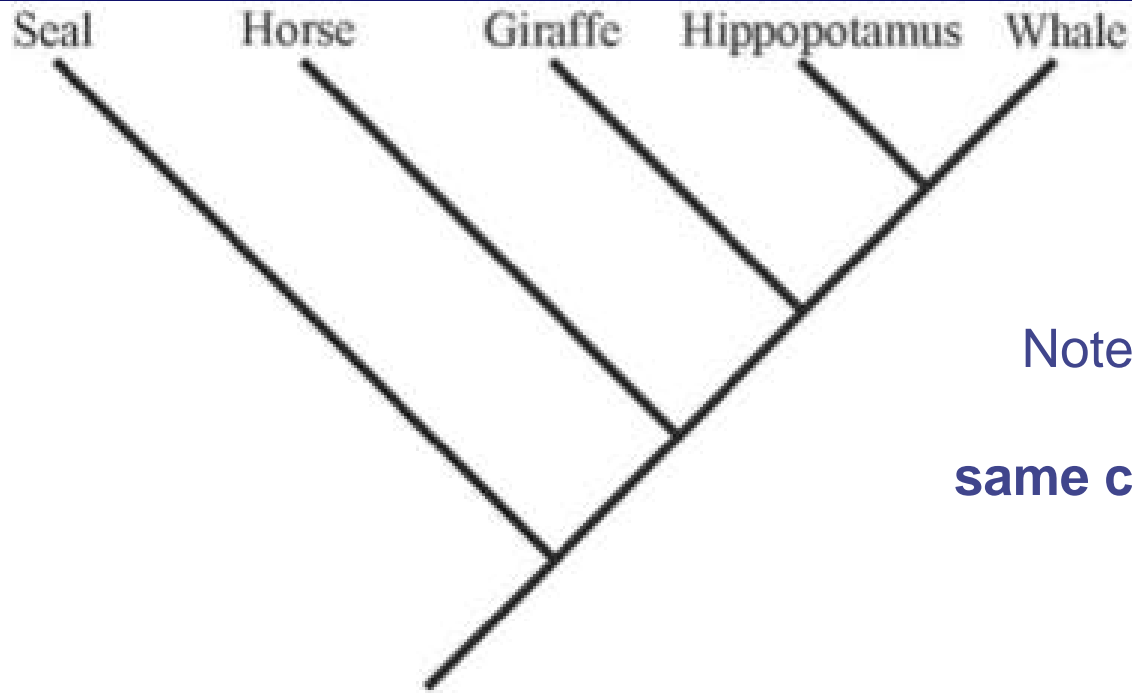

Answer is C.
Note that seal, horse & whale
diverge from
same common ancestor (NODE).

1. By reference to the tree above, which of the following is an accurate statement of relationships? *Explain your answer.*

- a) A seal is more closely related to a horse than to a whale
- b) A seal is more closely related to a whale than to a horse
- c) A seal is equally related to a horse and a whale**
- d) A seal is related to a whale, but is not related to a horse

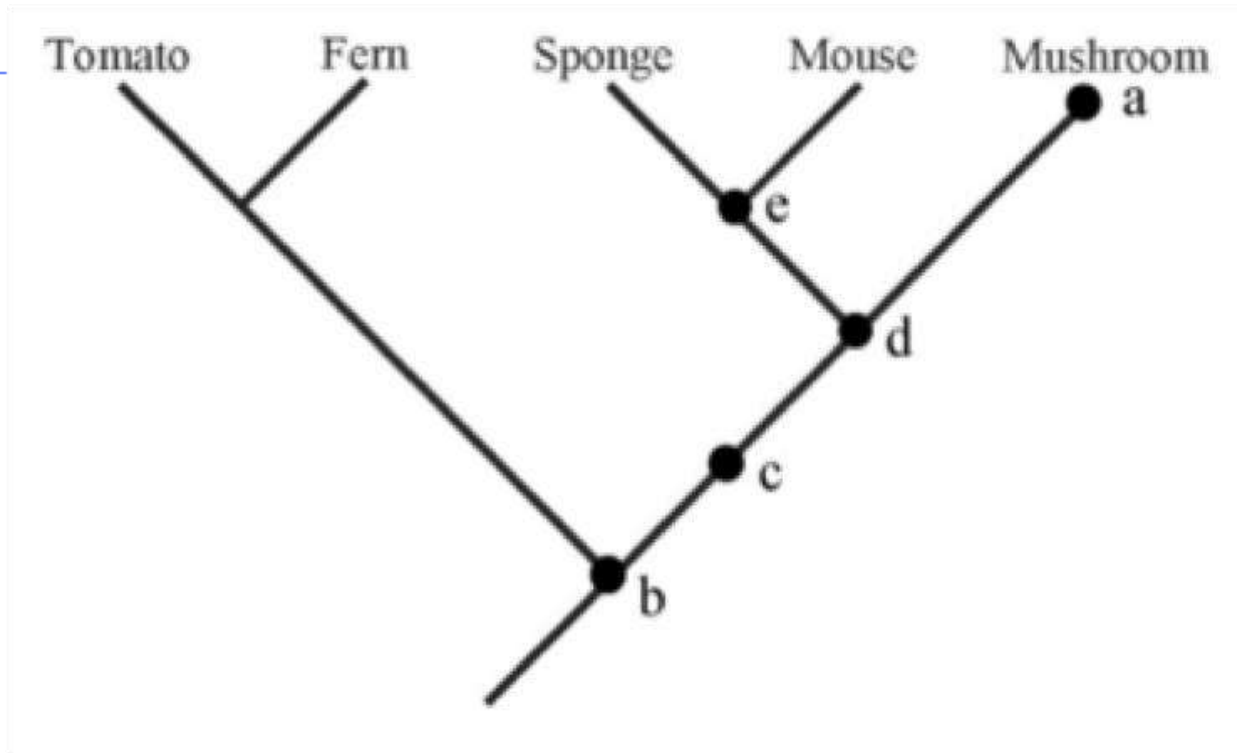

2. Which of the five marks in the tree above corresponds to the most recent common ancestor of a mushroom and a sponge?

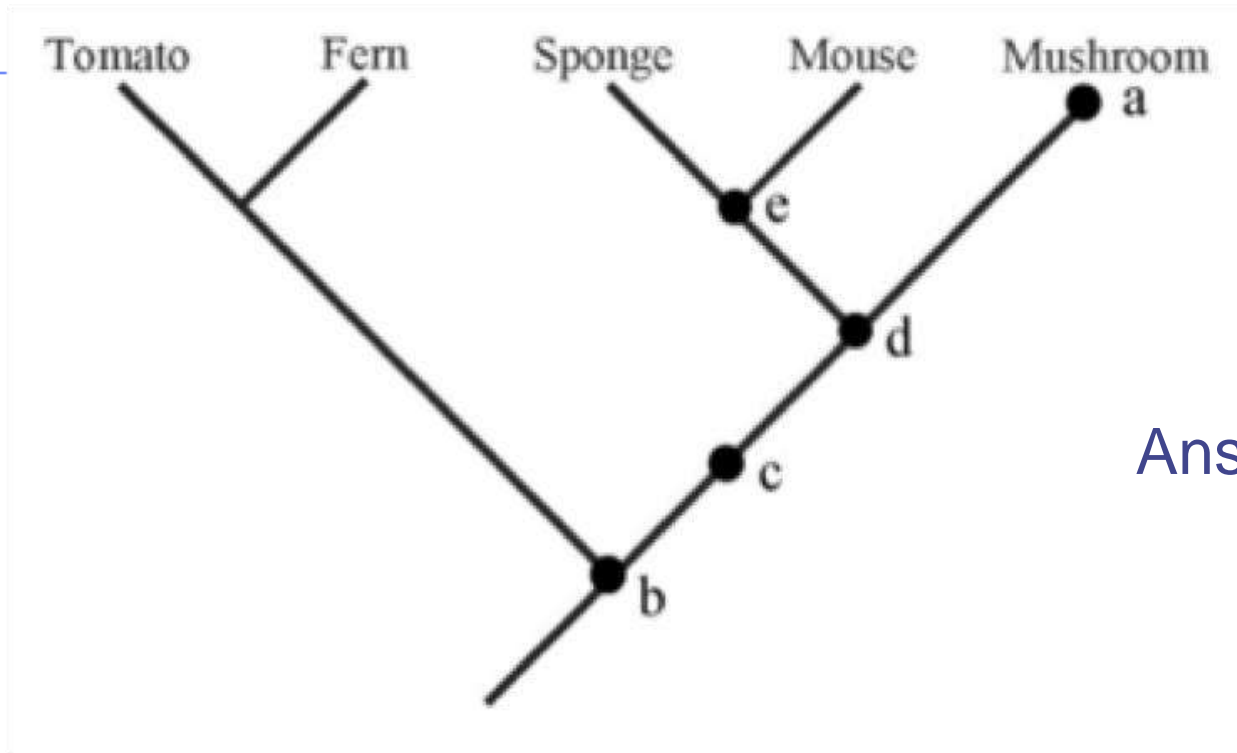

Answer is d.

2. Which of the five marks in the tree above corresponds to the most recent common ancestor of a mushroom and a sponge?

#3 Application Problem

3. Study the following data regarding shared derived characteristics of various vertebrate animals. (X indicates that the animal possesses the trait.)

Animals

TRAITS	Kangaroo	Lamprey	Rhesus Monkey	Bullfrog	Human	Snapping Turtle	Tuna
Dorsal Nerve Cord Notochord	X	X	X	X	X	X	X
Paired Appendages Vertebral column	X		X	X	X	X	X
Paired legs	X		X	X	X	X	
Amnion (Amniotic sac)	X		X		X	X	
Mammary Glands	X		X		X		
Placenta			X		X		
Canine teeth short Foramen magnum fwd					X		
TOTALS of Xs----->	5	1	6	3	7	4	2

1. Draw a Venn Diagram to represent how these animals are related. Indicate shared derived traits in each subset of the diagram.
2. Next, construct a rooted cladogram that reflects your hypothesis about the evolutionary relatedness. Indicate the shared derived traits at the appropriate branchpoints.
3. Draw a circle around the clade that includes all mammals.
4. Name a shared ancestral trait for the mammals.
5. Name a shared derived trait for the mammals.

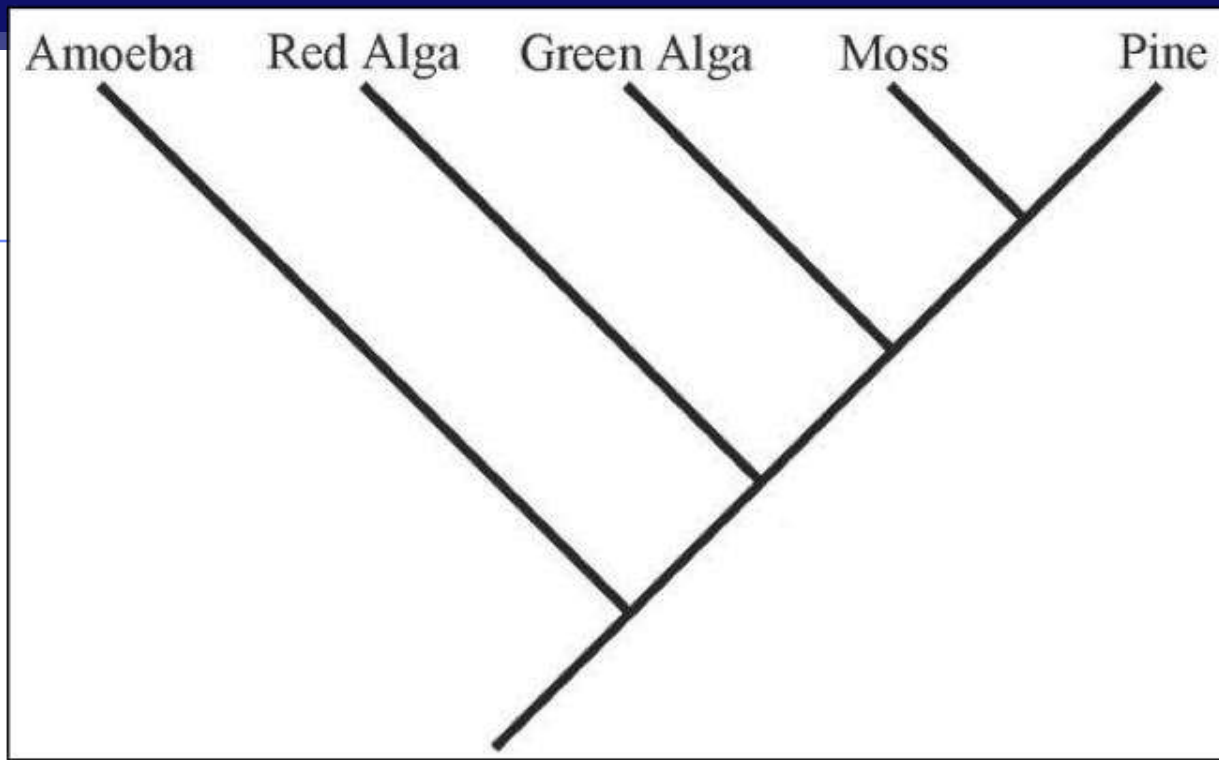

By reference to the tree above, which of the following is an accurate statement of relationships?

- a) A green alga is more closely related to a red alga than to a moss**
- b) A green alga is more closely related to a moss than to a red alga**
- c) A green alga is equally related to a red alga and a moss**
- d) A green alga is related to a red alga, but is not related to a moss**

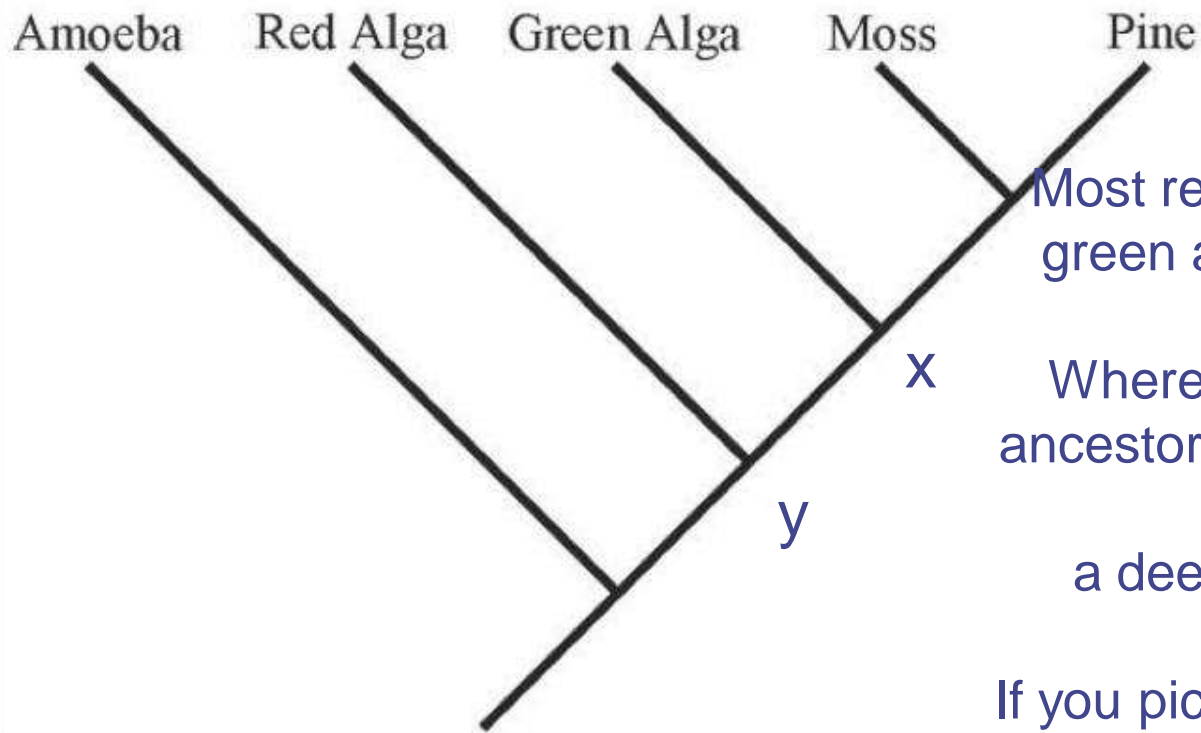

Answer is B.

Most recent common ancestor of green alga and moss at node X.

Whereas, most recent common ancestor of green alga and red alga at node Y...
a deeper, more ancient node.

If you picked C, likely reading at tips and not nodes.

By reference to the tree above, which of the following is an accurate statement of relationships?

- a) A green alga is more closely related to a red alga than to a moss
- b) A green alga is more closely related to a moss than to a red alga
- c) A green alga is equally related to a red alga and a moss
- d) A green alga is related to a red alga, but is not related to a moss

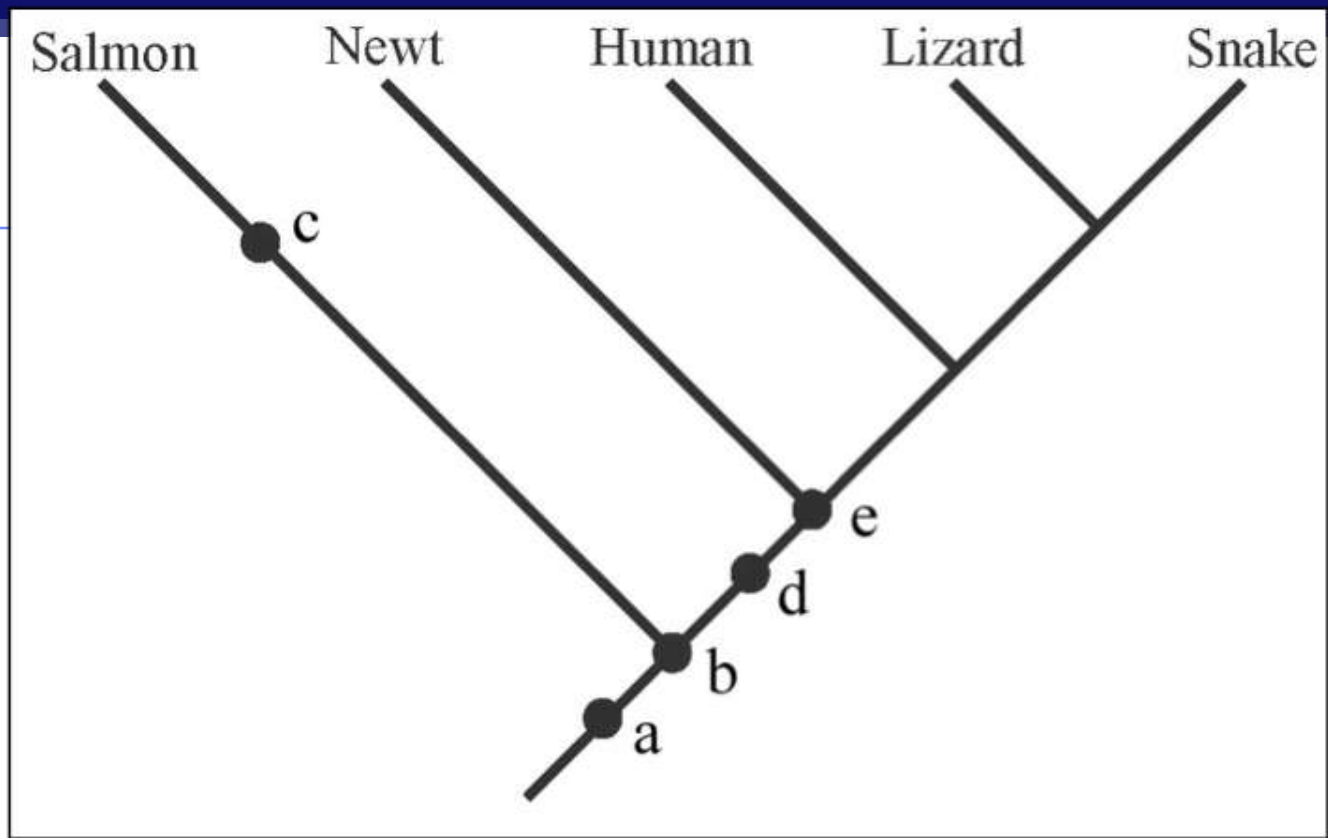

If you were to add a *trout* to the phylogeny shown above, where would its lineage attach to the rest of the tree?

Cladogram

- *Which share a common ancestor?*
- *Which are more/less closely related?*

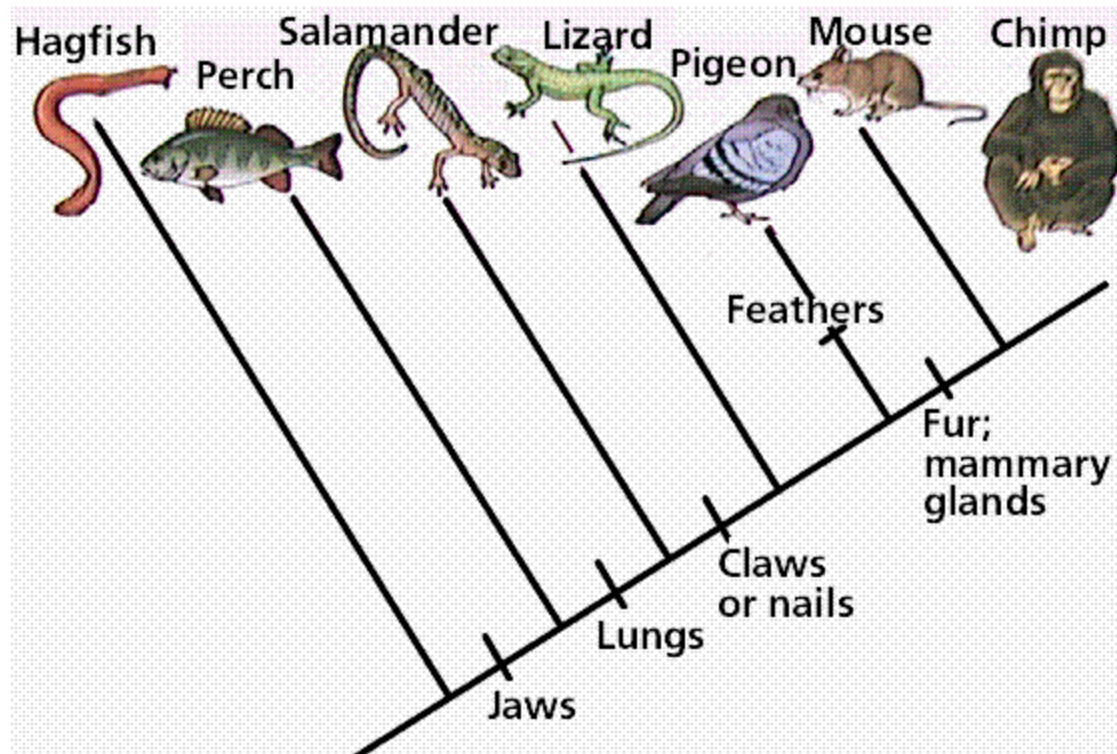

Papa??

