

BIOLOGY: INTEGRATING CORE TO ESSENTIAL VARIABLES (Bio-ICE)

TASK TEAM REPORTS INTRODUCTION



OVERVIEW

To effectively and efficiently gauge the state of our ocean, in particular its ecological resources, national and international initiatives have been collecting biological and biogeochemical variables in a sustained way which provide information on the health of ocean resources and can serve as indicators of change. In 2012, the Global Ocean Observing System (GOOS) developed a set of essential ocean variables (EOVs) with the goal of standardizing the variables that are most important for ocean observing, routinely collected by ocean observing systems, and for which common standards could be developed for data collection and sharing. While defining the EOVs was a relatively straightforward process which was carried out by GOOS expert panels, gauging the level of existing implementation (groups that already collect these data) and opportunities to expand adoption of standards and best practices for EOV collection has been more difficult; many observing systems have been sampling EOVs for a long time, but have used slightly different terminology for the same variables which has made reconciling the level of EOV implementation difficult.

In order to address this issue for biology and ecosystem variables and to reconcile historical variable names with those defined by large international initiatives such as the EOVs, the Integrated Ocean Observation Committee (IOOC) appointed the Biology-Integrating Core to Essential Variables (Bio-ICE) Task Team to cross-reference U.S. Integrated Ocean Observing System (IOOS) core biological variables with GOOS EOVs and the Group on Earth Observations' Essential Biodiversity Variables (EBVs), and to understand where improvements could be made regarding best practices and standardized data collection and delivery, while adhering to the Findable, Accessible, Interoperable, Reusable (FAIR) and Collective Benefit, Authority to Control, Responsibility, Ethics (CARE) data principles as appropriate. This is the first time such an effort has been done at a national level, leveraging the IOOS structure. It is expected that the outputs of this Task Team, which focused on only two core variables as pilot, can be expanded to other variables and provide the basis for similar efforts at an international level, thereby advancing the implementation of EOVs and EBVs, and the standardization and dissemination of valuable ocean data.

EXECUTIVE SUMMARY

GOOS expert panels are responsible for three main functions within their discipline:

- Identification of and requirement setting for Essential Ocean Variables (EOVs);
- Development of EOV implementation strategies and coordination of observations; and
- Promotion of standards and interoperability of data and information products.

The GOOS biology and ecosystem EOVs were identified through extensive review of societal needs and analysis of over 20 international conventions and multilateral agreements relevant for marine life ([Miloslavich et al. 2018](#)). The review assessed the current state of ocean observations measured by over 100 observing programs, and the impact, feasibility and scalability of these variables and how they contribute to addressing societal and scientific issues. Eight EOVs were selected through a driver-pressure-state-impact-response (DPSIR) model based on criteria such as the ability to answer scientific questions; ability to address societal needs; ability to inform management of marine resources; and the feasibility of taking measurements globally with considerations to cost, available technologies, and human resources. The resulting “BioEco” EOVs include functional groups that meet these criteria along with variables representing biogenic habitat state.

The Essential Biodiversity Variables (EBVs) emerging through the Group on Earth Observations Biodiversity Observation Network (GEO BON) complement the BioEco EOVs in that they address essential dimensions of biodiversity and the magnitude and direction of biodiversity change ([Muller-Karger et al. 2018](#)); in fact EBVs are often captured as sub-variables of the BioEco EOVs in specification sheets developed by the expert communities. EBVs are biological measurements intended to capture critical scales and dimensions of biodiversity using approaches that are technically feasible, economically viable, and sustainable. They look across the different levels of biological organization: genes, species, populations, and ecosystems, and at some general (and sometimes overlapping) categories such as genetics, taxonomy, function, and structure. The six classes of EBVs are genetic composition, species populations, species traits, community composition, ecosystem structure, and ecosystem function.

The goal of the Bio-ICE Task Team, convened from July 2020 - January 2022, was to advance the integration of biological observations from local, regional, and federal sources using best practices to inform national needs and ultimately feed into GOOS data visualizations and reporting. Using the GOOS marine mammals and corals EOVs as examples, the Task Team sought to:

1. Reconcile U.S. federal collection of these variables with GOOS EOVs and the Group on Earth Observations’ EBVs, identifying synergies in spatial and temporal observing requirements and with existing observation infrastructure and delivery, including use of documented best practices and standards.
2. Identify and improve pathways for data flow for observations of these variables from the IOOS Regional Associations and federal sources into common data portals. This included a focus on identifying and implementing best practices for standardized data collection and delivery adhering to the FAIR and CARE data principles, as appropriate.

The Task Team effort focused on corals and marine mammals to ensure the work of the task team was achievable within the time frame. These two EOVs were selected because of their importance to multiple stakeholders, as well as offering opportunities to tie-in to several critical U.S. priorities in ocean science. While the team chose this focus, it acknowledged that there are activities and communities working to advance the other biology and ecosystem essential variables in ways that might be similar to or synergistic with the task team, such as SCOR Working Group 158: Coordinated Global Research Assessment of Seagrass System (C-GRASS), global efforts to coordinate ocean sound monitoring and data, GOOS BioEco panel community workshops and ongoing panel activities, and other efforts worth tracking or considering for future engagement with IOOC.

Both the corals and the mammal EOVs are of interest to a range of local, regional, tribal and federal stakeholders, and they are directly responsive under two of the goals of the Subcommittee for [Ocean Science and Technology's \(SOST's\) Science and Technology for America's Oceans: A Decadal Vision report](#). Specifically, under Goal I "Understand the Ocean in the Earth System," the acoustic datasets used to assess occurrence, distribution, abundance, phenology, and density of marine mammals, as well as the satellite data sets and/or towed-diver/video surveys used to evaluate spatial coverage and potentially species composition of corals, are relevant to the Harness Big Data section within the Decadal Vision report. Additionally, both of these variables are of interest under Goal II, "Promote Economic Prosperity." Preserving coral reefs has both ecological benefit (biodiversity maintenance) and economic benefit (provision of critical habitat to larval and juvenile stages of some commercially harvested species and tourism). Coral reefs may provide goods and services worth \$375 billion each year, an impressive figure for an environment that covers less than 1 percent of the Earth's surface. For marine mammals, the ecological benefit to mammal-driven nutrient turnover supports healthy fish stocks, which have a direct connection to commercial fisheries, and whale-watching and tourism provide a substantial economic benefit. One study puts the value of the average great whale, based on its various activities, at more than \$2 million, making the value of the entire current stock of great whales easily over \$1 trillion ([Pershing et al. 2010](#)).

The task team leveraged existing infrastructure and information to improve the integration of fit-for-purpose marine mammal and coral observations from local, regional, and federal sources using standardized best practices. This will inform national needs, feed seamlessly into the Global Ocean Observing System, and provide a roadmap for IOOS to improve delivery of its other core biological variables consistent with national and global requirements. Deliverables presented here include (1) a summary of the synergies between IOOS core variables, GOOS BioEco EOVs and EBVs for marine mammals and corals in terms of spatial and temporal observing requirements and existing observation infrastructure and delivery, (2) identification of best practices in use in the United States for observing these variables, (3) an overview of submission of existing or new materials to the IOC Ocean Best Practices Repository, and (4) an evaluation of how well the variables are being implemented (observation to information delivery to meet requirements) as the task team sunsets.

OUTCOMES AND RECOMMENDATIONS

A summary of the work process, outcomes, and next steps from the Task Team subgroups is presented in the marine mammals and corals subgroup reports, linked [here](#). Two major outcomes emerged common to both groups and relevant across IOOS and partner biology and ecosystem observing efforts, described below.

IOOS Core Variables and GOOS EOVS Naming Conventions

The Task Team discussed whether and how to more directly align IOOS core variables with the GOOS EOVS. After reviewing the lists of IOOS core biological variables and GOOS BioEco EOVS, the group determined that in the majority of cases the GOOS EOVS are referring to the same things as the IOOS core variables but with more accurate nomenclature.

The task team recommends that IOOS adopt the GOOS BioEco EOVS naming, as follows:

IOOS Core Variable	GOOS EOVS/Revised IOOS Core Variable
Coral species and abundance	Hard coral cover and composition*
Submerged aquatic vegetation species and abundance	Macroalgal canopy cover and composition
[Submerged aquatic vegetation species and abundance]?	Mangrove cover and composition
Submerged aquatic vegetation species and abundance	Seagrass cover and composition
Microbial species, abundance, and activity	Microbe biomass and diversity
Phytoplankton species and abundance	Phytoplankton biomass and diversity
Zooplankton species and abundance	Zooplankton biomass and diversity
Invertebrate species and abundance	Invertebrate abundance and distribution
Fish species and abundance	Fish abundance and diversity
Sea bird species and abundance	Sea bird abundance and distribution
Sea turtle species and abundance	Sea Turtle abundance and distribution
Marine mammal species and abundance	Marine mammal abundance and distribution*
Sound	Ocean Sound
Ocean Color	Ocean Color
Biological vital rates	
Nekton diet	
Microbial activity	

*The Task Team membership focused their efforts on these topics based on their importance to multiple stakeholders and tie-in to several critical U.S. priorities in ocean science. Additional context and rationale can be found in the [scope of work](#).

Data Flow

Despite the information on biological and biogeochemical variables available now, the availability of and accessibility to the original data, delivery of information and other products to the broader ocean observing community, and contribution to the EOVs and EBVs remains inconsistent. To improve this situation the task team developed preferred and alternative data flow pathways (Figure 1) based on various methods that can be used to collect biological and biogeochemical data. To be successful, the data flows must ensure that the data are provided in aggregated, standardized, and easily manipulated ways; and ideally would be applicable to other EOVs as well.

One globally-recognized way to standardize data is to use the Darwin Core data standard. Darwin Core is a standard glossary of terms used for sharing and integration of biological diversity data (Wieczorek et al. 2012). Darwin Core was originally designed for natural history collection data but has grown in use and applicability with its adoption by global biodiversity data aggregator repositories like the Ocean Biodiversity Information System (OBIS) and the Global Biodiversity Information Facility (GBIF). Further, Darwin Core has been adopted by GOOS. Once data are standardized, they can be integrated into global aggregation systems like OBIS and can easily be reused by data analysts all over the world to answer scientific questions and create products useful to managers, conservationists, and other stakeholders.

BIO-ICE EOVS Data Flow

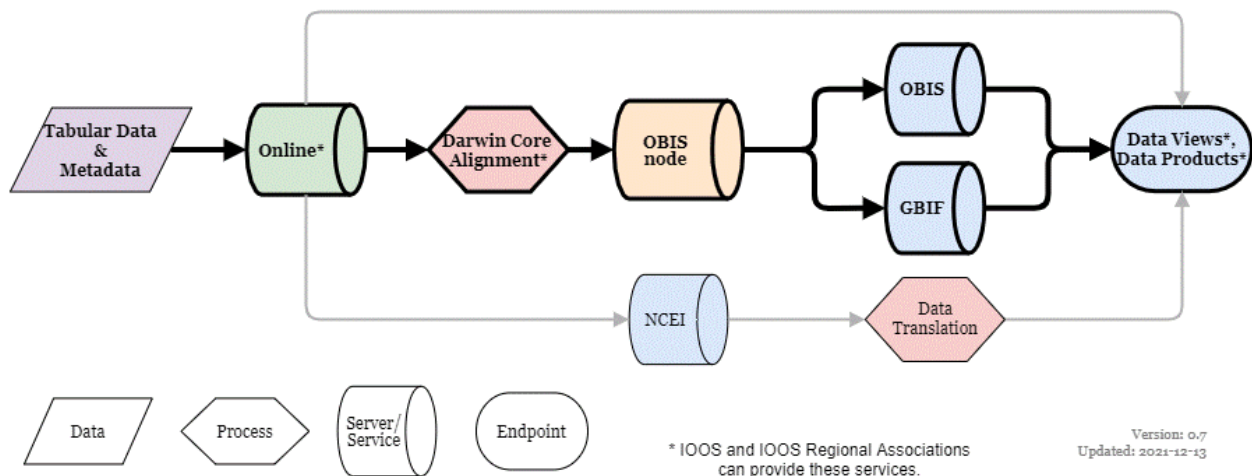

FIGURE 1: Data flow diagram depicting preferred (bolded black lines) and alternate (gray lines) data flows for biological observing data to inform biology and ecosystem visualizations and products.

On the left we start with tabular data and metadata in the format most useful for the project the data were collected for. The data are then put online in this project specific format so they are accessible. To improve reuse and interoperability of the data, they are aligned to the data standard Darwin Core. Once the data are standardized to Darwin Core, they can be included in an OBIS node. The OBIS node then makes the data available to the global aggregators OBIS and GBIF. Once many datasets are aggregated together, data views and products can be developed to assess abundance and distribution across projects. By aligning the naming conventions and identifying data flow pathway(s) the task team successfully met two of its goals for both marine mammals and corals. For the details of the work process, outcomes, and next steps from the Task Team subgroups, see their individual reports linked below.

► [Bio-ICE Corals Report](#)

► [Bio-ICE Mammals Report](#)