

Gain Test Prep - ACT Preparation Course Outline

Math/Science Instructor: Alan Tupaj

Email: amtupaj@murrieta.k12.ca.us

Website: www.vmhs.net

Click on Teachers then Tupaj, Alan

Session 1

- Introduction
- Pre-Algebra Content
- Pre-Algebra Practice
- Science Interpretation of Data Content
- Science Interpretation of Data Practice
- Algebra 1 Content
- Homework:
 - Practice Test #1, Math and Science Sections, No timing
 - Read Chapter 6 – Improving Your Math Score

Session 2

- Homework Questions
- Algebra 2 Content
- Algebra 1 and Algebra 2 Practice
- Science Scientific Investigation Content
- Science Scientific Investigation Practice
- Homework:
 - Practice Test #2, Math and Science Sections, Timed
 - Read Chapter 8 – Improving Your Science Score

Session 3

- Homework Questions
- Geometry Content
- Geometry Practice
- Science Evaluation of Models Content
- Science Evaluation of Models Practice
- Homework:
 - Practice Test #3, Math and Science Sections, Timed
 - Read Chapter 2 – Preparation, Skills, and Strategies

Session 4

- Homework Questions
- Statistics and Probability Content
- Statistics and Probability Practice
- Mixed Difficult Problem Strategies
- Mixed Difficult Problem Practice
- Chapter 4 - Identifying areas of improvement
- Course Evaluation

ACT Practice Sites

<http://www.act.org/content/act/en/products-and-services/the-act/test-preparation/math-practice-test-questions.html?page=0&chapter=1>

5 sets of practice problems not by topic

<http://blog.prepscholar.com/complete-list-of-free-act-math-practice-questions>

Lots of questions by topic

https://www.varsitytutors.com/act_math-help

Lots of questions by topic

<http://www.crackact.com/act/math/>

80 short practice tests (15 problems each) and 2 full practice tests

<https://www.sophia.org/preparing-for-college/act-test-preparation/mathematics>

Video reviews by topic. Practice Tests require an account

https://www.powerscore.com/sat/help/content_practice_tests.cfm#official-act

Extra official practice tests, both ACT and SAT

<http://www.sparknotes.com/testprep/books/act/chapter10.rhtml>

Content overview by topic . No practice problems

<http://www.mhpracticeplus.com/act.php>

4 online non-official practice tests. Limited videos by topic

<https://www.mometrix.com/academy/act-math/>

Lots of topical math videos

<http://www.highschooltestprep.com/act/math/>

Online practice tests in order of difficulty

Session 1

Pre-Algebra Skills Checklist

1. Reducing and comparing fractions

In which of the following are $\frac{1}{2}$, $\frac{5}{6}$, and $\frac{5}{8}$ arranged in ascending order?

F. $\frac{1}{2} < \frac{5}{8} < \frac{5}{6}$

G. $\frac{5}{6} < \frac{1}{2} < \frac{5}{8}$

H. $\frac{5}{6} < \frac{5}{8} < \frac{1}{2}$

J. $\frac{5}{8} < \frac{1}{2} < \frac{5}{6}$

K. $\frac{5}{8} < \frac{5}{6} < \frac{1}{2}$

2. Operations on fractions and mixed numbers

A container is $\frac{1}{8}$ full of water. After 10 cups of water are added, the container is $\frac{3}{4}$ full. What is the volume of the container, in cups?

F. $13\frac{1}{3}$

G. $13\frac{1}{2}$

H. 15

J. 16

K. 40

3. Identify or compare types of numbers

Which of the following is a rational number?

A. $\sqrt{2}$

B. $\sqrt{\pi}$

C. $\sqrt{7}$

D. $\sqrt{\frac{5}{25}}$

E. $\sqrt{\frac{64}{49}}$

4. Prime factorization

Which of the following lists all the positive factors of 8?

A. 1, 8

B. 2, 4

C. 2, 4, 6

D. 8, 16, 32

E. 1, 2, 4, 8

5. Exponent rules including scientific notation

Which of the following is equivalent to $(4x^2)^3$?

F. $64x^8$

G. $64x^6$

H. $12x^6$

J. $12x^5$

K. $4x^6$

6. Absolute value

$$|7 - 3| - |3 - 7| = ?$$

A. -8

B. -6

C. -4

D. 0

E. 8

7. Percent problems with numerical values

If 40% of a given number is 8, then what is 15% of the given number?

A. 1.2

B. 1.8

C. 3.0

D. 5.0

E. 6.5

8. Greatest common factor and least common multiple

For all positive integers x , what is the greatest common factor of the 2 numbers $216x$ and $180x$?

F. 6

G. 72

H. x

J. $12x$

K. $36x$

9. Patterns of prime numbers

If Set A consists of all prime numbers and Set B consists of all multiples of 3, which of the following represents the intersection of Set A and Set B?

- A. {3}
- B. {1, 3}
- C. {1, 3, 6, 9, 12, 15, ...}
- D. {1, 3, 9, 15, 21, 27, ...}
- E. {1, 2, 3, 4, 5, 6, 7, ...}

10. Solve simple equations

If $7 + 3x = 22$, then $2x = ?$

- F. 5
- G. 10
- H. 12
- J. 14
- K. $\frac{58}{3}$

11. Evaluate expression by substituting values for variables

What is the value of the expression $(x - y)^2$ when $x = 5$ and $y = -1$?

- F. 4
- G. 6
- H. 16
- J. 24
- K. 36

12. Combine like terms including distributing

Which of the following is an equivalent simplified expression for $2(4x + 7) - 3(2x - 4)$?

- F. $x + 2$
- G. $2x + 2$
- H. $2x + 26$
- J. $3x + 10$
- K. $3x + 11$

13. Solve ratio problems including rates of change

Vehicle A averages 14 miles per gallon of gasoline, and Vehicle B averages 36 miles per gallon of gasoline. At these rates, how many more gallons of gasoline does Vehicle A need than Vehicle B to make a 1,008-mile trip?

- A. 25
- B. 28
- C. 44
- D. 50
- E. 72

Pre-Algebra Practice Problems

1.

On a particular road map, $\frac{1}{2}$ inch represents 18 miles. About how many miles apart are 2 towns that are $2\frac{1}{2}$ inches apart on this map?

- A. 18
- B. $22\frac{1}{2}$
- C. 36
- D. 45
- E. 90

2.

Given $f = cd^3$, $f = 450$, and $d = 10$, what is c ?

- F. 0.45
- G. 4.5
- H. 15
- J. 45
- K. 150

3.

Jorge's current hourly wage for working at Denti Smiles is \$12.00. Jorge was told that at the beginning of next month, his new hourly wage will be an increase of 6% of his current hourly wage. What will be Jorge's new hourly wage?

- F. \$12.06
- G. \$12.60
- H. \$12.72
- J. \$18.00
- K. \$19.20

4.

In scientific notation, $670,000,000 + 700,000,000 = ?$

- A. 1.37×10^{-9}
- B. 1.37×10^7
- C. 1.37×10^8
- D. 1.37×10^9
- E. 137×10^{15}

5.

Which of the following expressions is equivalent to

$$\frac{1}{2}y^2(6x + 2y + 12x - 2y) ?$$

- A. $9xy^2$
- B. $18xy$
- C. $3xy^2 + 12x$
- D. $9xy^2 - 2y^3$
- E. $3xy^2 + 12x - y^3 - 2y$

6.

What fraction lies exactly halfway between $\frac{2}{3}$ and $\frac{3}{4}$?

- F. $\frac{3}{5}$
- G. $\frac{5}{6}$
- H. $\frac{7}{12}$
- J. $\frac{9}{16}$
- K. $\frac{17}{24}$

7.

A number is increased by 25% and the resulting number is then decreased by 20%. The final number is what percent of the original number?

- A. 90%
- B. 95%
- C. 100%
- D. 105%
- E. 120%

8.

What is the smallest integer greater than $\sqrt{58}$?

- A. 4
- B. 7
- C. 8
- D. 10
- E. 30

9.

Sergio plans to paint the 4 walls of his room with 1 coat of paint. The walls are rectangular, and, according to his measurements, each wall is 10 feet by 15 feet. He will not need to paint the single 3-foot-by-5-foot rectangular window in his room and the $3\frac{1}{2}$ -foot-by-7-foot rectangular door. Sergio knows that each gallon of paint covers between 300 and 350 square feet. If only 1-gallon cans of paint are available, which of the following is the minimum number of cans of paint Sergio needs to buy to paint his walls?

- F. 1
- G. 2
- H. 3
- J. 4
- K. 5

10.

For all $a > 1$, the expression $\frac{3a^4}{3a^6}$ equals:

- F. $\frac{1}{2}$
- G. $-a^2$
- H. a^2
- J. $-\frac{1}{a^2}$
- K. $\frac{1}{a^2}$

Science Sample Passage - Interpretation of Data

Passage IV

In 2 experiments, a student pulled each of 3 blocks in a straight line across a flat, horizontal surface.

In Experiment 1, the student measured the *pulling force* (the force required to move each block at a constant speed) and plotted the pulling force, in newtons (N), versus block mass, in kilograms (kg). The results are shown in Figure 1.

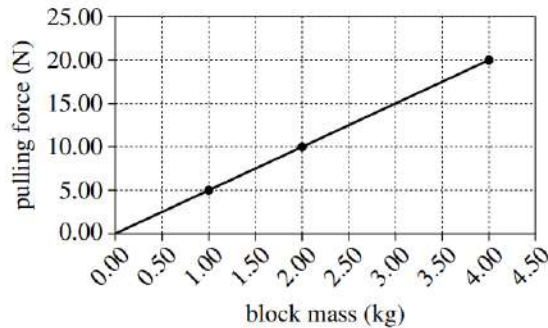

Figure 1

In Experiment 2, the student measured the speed versus time of a 2.00 kg block, a 2.50 kg block, and a 3.00 kg block as each block was pulled across the surface with a constant 30 N force. The results are shown in Figure 2.

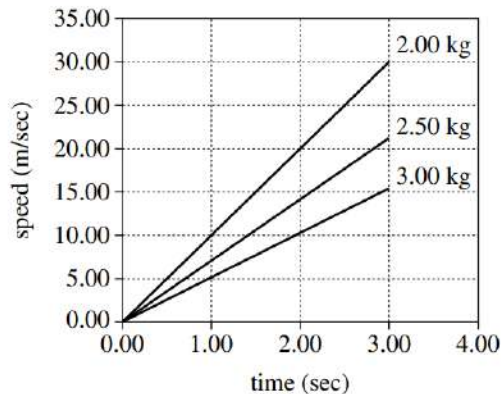

Figure 2

21. If a block was pulled toward the east, the frictional force exerted on the block by the surface was directed toward the:
- A. north.
 - B. south.
 - C. east.
 - D. west.
22. Based on Figure 2, what is the order of the 3 blocks, from the block that required the shortest time to reach 15 m/sec to the block that required the longest time to reach 15 m/sec?
- F. 2.00 kg block, 2.50 kg block, 3.00 kg block
 - G. 2.00 kg block, 3.00 kg block, 2.50 kg block
 - H. 3.00 kg block, 2.00 kg block, 2.50 kg block
 - J. 3.00 kg block, 2.50 kg block, 2.00 kg block

23. Based on Figure 2, what was the approximate value of the acceleration of the 3.00 kg block?
- A. 0.0 m/sec²
 - B. 5.0 m/sec²
 - C. 15.0 m/sec²
 - D. 20.0 m/sec²
24. Based on Figure 1, the results of Experiment 1 are best modeled by which of the following equations?
- F. Block speed (m/sec) = 0.2 × time (sec)
 - G. Block speed (m/sec) = 5.0 × time (sec)
 - H. Pulling force (N) = 0.2 × block mass (kg)
 - J. Pulling force (N) = 5.0 × block mass (kg)
25. At each of the times plotted in Figure 2 (except 0.00 sec), as block mass increased, block speed:
- A. increased only.
 - B. decreased only.
 - C. varied, but with no general trend.
 - D. remained the same.
26. Based on Figure 1, an applied force of 30.00 N would most likely have been required to maintain the constant speed of a block having a mass of:
- F. 4.00 kg.
 - G. 5.00 kg.
 - H. 6.00 kg.
 - J. 7.00 kg.

Practice Science Passages - Interpretation of Data

Passage III

Greenhouse gases such as methane (CH_4) warm Earth's climate. Figure 1 shows the concentration of CH_4 in Earth's atmosphere and the solar radiation intensity at Earth's surface for tropical Europe and Asia over the past 250,000 years. As the figure shows, the CH_4 concentration and the solar radiation intensity have increased and decreased at the same times over most of this period. Figure 2 shows the same types of data for the same region over the past 11,000 years. This figure is consistent with the hypothesis that the greenhouse gases from human activities may have begun warming Earth's climate thousands of years earlier than once thought.

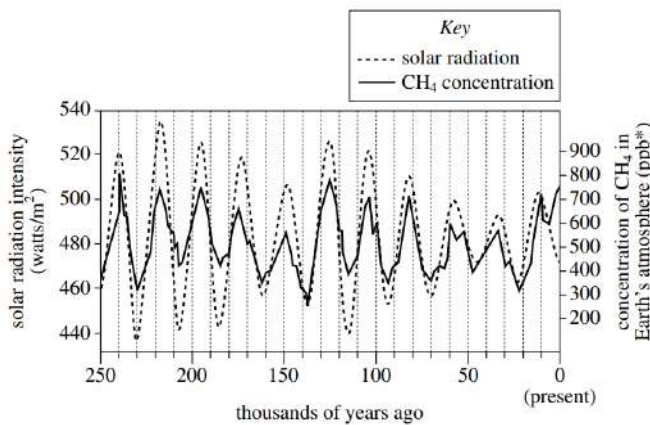

Figure 1

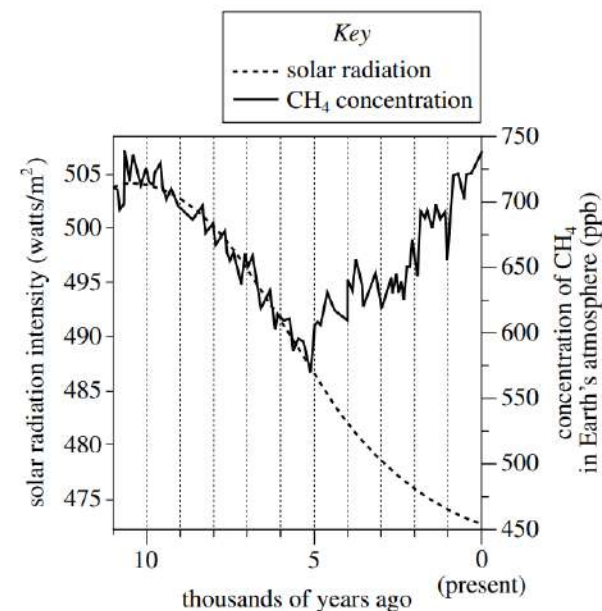

Figure 2

*ppb = parts per billion

15. According to Figure 2, the solar radiation intensity 8,000 years ago was closest to which of the following?
 - A. 490 watts/m²
 - B. 495 watts/m²
 - C. 500 watts/m²
 - D. 505 watts/m²

16. According to Figure 2, if the trend in the CH_4 concentration had continued to match the trend in the solar radiation intensity, the CH_4 concentration at present would most likely be:
 - F. less than 550 ppb.
 - G. between 550 ppb and 600 ppb.
 - H. between 600 ppb and 650 ppb.
 - J. greater than 650 ppb.

17. Suppose that whenever the CH_4 concentration increases, a corresponding, immediate increase in average global temperature occurs, and that whenever the CH_4 concentration decreases, a corresponding, immediate decrease in average global temperature occurs. Based on Figure 2, which of the following graphs best represents a plot of average global temperature over the past 11,000 years?

A.

C.

B.

D.

18. Based on Figure 1, the average solar radiation intensity over the past 250,000 years was closest to which of the following?
 - F. 400 watts/m²
 - G. 440 watts/m²
 - H. 480 watts/m²
 - J. 520 watts/m²

19. One *solar radiation cycle* is the time between a maximum in the solar radiation intensity and the next maximum in the solar radiation intensity. According to Figure 1, the average length of a solar radiation cycle during the past 250,000 years was:
 - A. less than 15,000 years.
 - B. between 15,000 years and 35,000 years.
 - C. between 35,000 years and 55,000 years.
 - D. greater than 55,000 years.

20. Which of the following statements best describes the primary effect of CH_4 on Earth's climate?
 - F. CH_4 gives off visible light to space, cooling Earth's climate.
 - G. CH_4 gives off ultraviolet radiation to space, warming Earth's climate.
 - H. CH_4 absorbs heat as it enters Earth's atmosphere from space, cooling Earth's climate.
 - J. CH_4 absorbs heat that comes up from Earth's surface, warming Earth's climate.

Passage VI

Drilling mud (DM) is a suspension of clay particles in water. When a well is drilled, DM is injected into the hole to lubricate the drill. After this use, the DM is brought back up to the surface and then disposed of by spraying it on adjacent land areas.

A cover of DM on plants and soil can affect the *albedo* (proportion of the total incoming solar radiation that is reflected from a surface), which in turn can affect the soil temperature. The effect of a cover of DM on the albedo and the soil temperature of an unsloped, semiarid grassland area was studied from July 1 to August 9 of a particular year.

On June 30, 3 plots (Plots 1–3), each 10 m by 40 m, were established in the grassland area. For all the plots, the types of vegetation present were the same, as was the density of the vegetation cover. At the center of each plot, a soil temperature sensor was buried in the soil at a depth of 2.5 cm. An instrument that measures incoming and reflected solar radiation was suspended 60 cm above the center of each plot.

An amount of DM equivalent to 40 cubic meters per hectare (m^3/ha) was then sprayed evenly on Plot 2. (One hectare equals $10,000 m^2$.) An amount equivalent to $80 m^3/ha$ was sprayed evenly on Plot 3. No DM was sprayed on Plot 1.

For each plot, the albedo was calculated for each cloudless day during the study period using measurements of incoming and reflected solar radiation taken at noon on those days (see Figure 1).

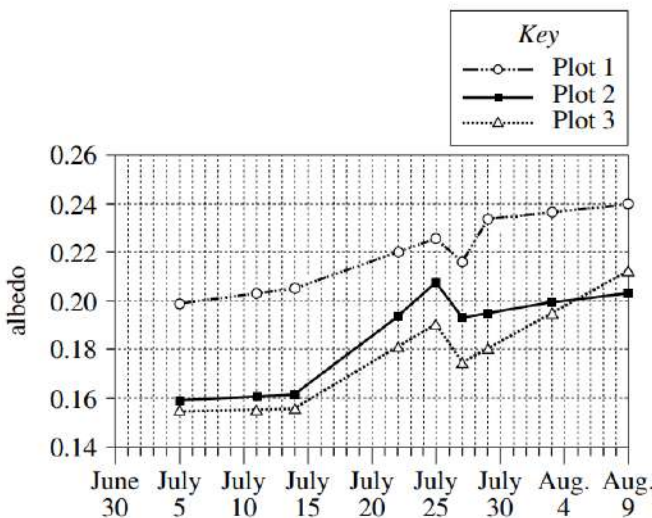

Figure 1

For each plot, the sensor recorded the soil temperature every 5 sec over the study period. From these data, the average soil temperature of each plot was determined for each day (see Figure 2).

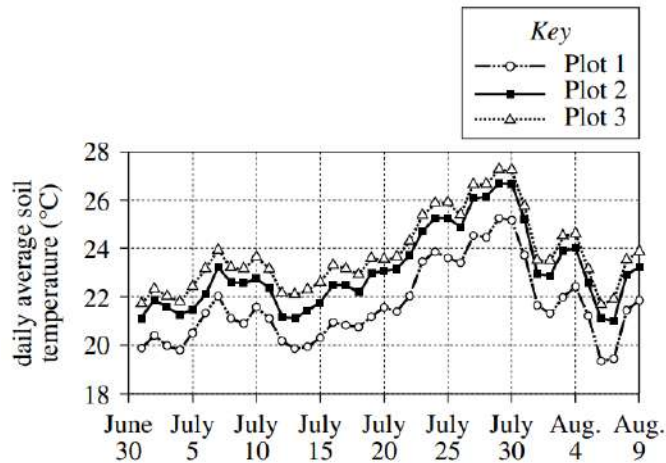

Figure 2

34. Albedo was measured at noon because that time of day is when solar radiation reaching the ground is:
 - F. 100% reflected.
 - G. 100% absorbed.
 - H. least intense.
 - J. most intense.

35. Why was the study designed so that the 3 plots had the same types of vegetation present and the same density of vegetation cover? These conditions ensured that any variations in albedo and soil temperature would most likely be attributable only to variations among the plots in the:
 - A. amount of DM sprayed.
 - B. type of soil present.
 - C. plot area.
 - D. plot slope.

36. On one day of the study period, a measurable rainfall occurred in the study area. The albedo calculated for the cloudless day just after the rainy day was lower than the albedo calculated for the cloudless day just before the rainy day. On which day did a measurable rainfall most likely occur in the study area?
 - F. July 10
 - G. July 12
 - H. July 26
 - J. July 28

37. For each plot, the number of temperature readings recorded by the soil temperature sensor every minute was closest to which of the following?
 - A. 5
 - B. 12
 - C. 50
 - D. 60

38. According to Figure 1 and the description of the study, was July 20 a cloudless day?
 - F. No, because albedo data were not collected on that day.
 - G. No, because albedo data were collected on that day.
 - H. Yes, because albedo data were not collected on that day.
 - J. Yes, because albedo data were collected on that day.

39. According to the results of the study, did the presence of a cover of DM increase or decrease the albedo, and did the presence of a cover of DM increase or decrease the soil temperature?

	<u>albedo</u>	<u>soil temperature</u>
A.	increase	increase
B.	increase	decrease
C.	decrease	decrease
D.	decrease	increase

40. Based on Figure 1, on August 3, what percent of incoming solar radiation was NOT reflected from Plot 2 ?

- F. 20%
- G. 40%
- H. 60%
- J. 80%

Algebra 1 Skills Checklist

1. Solve linear equations

When $\frac{1}{3}k + \frac{1}{4}k = 1$, what is the value of k ?

- A. $\frac{1}{7}$
- B. $\frac{12}{7}$
- C. $\frac{7}{2}$
- D. 6
- E. 12

2. Translate verbal expressions to algebraic expressions or equations

Two enterprising college students decide to start a business. They will make up and deliver helium balloon bouquets for special occasions. It will cost them \$39.99 to buy a machine to fill the balloons with helium. They estimate that it will cost them \$2.00 to buy the balloons, helium, and ribbons needed to make each balloon bouquet. Which of the following expressions could be used to model the total cost for producing b balloon bouquets?

- A. \$ $2.00b + \$39.99$
- B. \$ $37.99b$
- C. \$ $39.99b + \$ 2.00$
- D. \$ $41.99b$
- E. \$ $79.98b$

3. Solve linear inequalities

The inequality $3(x + 2) > 4(x - 3)$ is equivalent to which of the following inequalities?

- F. $x < -6$
- G. $x < 5$
- H. $x < 9$
- J. $x < 14$
- K. $x < 18$

4. Solve and graph compound inequalities

The number line graph below is the graph of which of the following inequalities?



- A. $-1 \leq x$ and $3 \leq x$
- B. $-1 \leq x$ and $3 \geq x$
- C. $-1 \leq x$ or $3 \leq x$
- D. $-1 \geq x$ or $3 \leq x$
- E. $-1 \geq x$ or $3 \geq x$

5. Solve word problems with linear equations or inequalities

This month, Kami sold 70 figurines in 2 sizes. The large figurines sold for \$12 each, and the small figurines sold for \$8 each. The amount of money he received from the sales of the large figurines was equal to the amount of money he received from the sales of the small figurines. How many large figurines did Kami sell this month?

- A. 20
- B. 28
- C. 35
- D. 42
- E. 50

6. Solve consecutive integer problems

The 6 consecutive integers below add up to 447.

$$\begin{aligned} &x - 2 \\ &x - 1 \\ &x \\ &x + 1 \\ &x + 2 \\ &x + 3 \end{aligned}$$

What is the value of x ?

- F. 72
- G. 73
- H. 74
- J. 75
- K. 76

7. Solve rate, time, distance problems

Ms. Lewis plans to drive 900 miles to her vacation destination, driving an average of 50 miles per hour. How many miles per hour faster must she average, while driving, to reduce her total driving time by 3 hours?

- A. 5
- B. 8
- C. 10
- D. 15
- E. 18

8. Multiply binomials

For all x , $(3x + 7)^2 = ?$

- A. $6x + 14$
- B. $6x^2 + 14$
- C. $9x^2 + 49$
- D. $9x^2 + 21x + 49$
- E. $9x^2 + 42x + 49$

9. Factor binomials and trinomials

Which of the following is a factored form of the expression $5x^2 - 13x - 6$?

- A. $(x - 3)(5x + 2)$
- B. $(x - 2)(5x - 3)$
- C. $(x - 2)(5x + 3)$
- D. $(x + 2)(5x - 3)$
- E. $(x + 3)(5x - 2)$

10. Find slope and y-intercept and equations of lines

What is the slope of the line through $(-5, 2)$ and $(6, 7)$ in the standard (x, y) coordinate plane?

- F. 9
- G. 5
- H. -5
- J. $\frac{5}{11}$
- K. $-\frac{5}{11}$

11. Graph linear equations

Which of the following is the graph of the equation $2x + y = 4$ in the standard (x, y) coordinate plane?

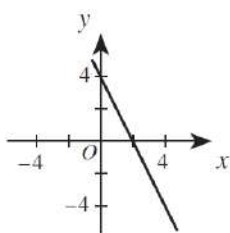
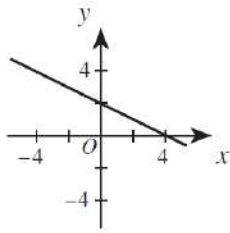
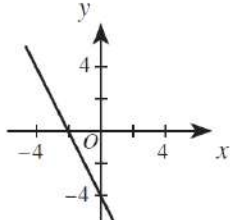
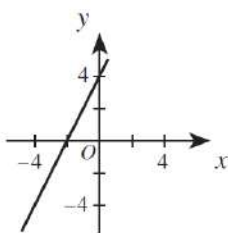
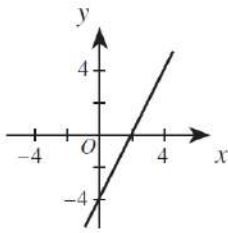
- A. 
- B. 
- C. 
- D. 
- E. 

12. Operations on polynomials

What polynomial must be added to $x^2 - 2x + 6$ so that the sum is $3x^2 + 7x$?

- A. $4x^2 + 5x + 6$
- B. $3x^2 + 9x + 6$
- C. $3x^2 + 9x - 6$
- D. $2x^2 + 9x - 6$
- E. $2x^2 - 5x + 6$

13. Solve quadratic equations

What values of x are solutions for $x^2 + 2x = 8$?

- A. -4 and 2
- B. -2 and 0
- C. -2 and 4
- D. 0 and 2
- E. 6 and 8

14. Solve equations with fractional exponents or radicals

If $\sqrt{2x} + 5 = 9$, then $x = ?$

- A. -4
- B. 2
- C. 4
- D. 8
- E. 16

15. Solve systems of linear equations

The sum of the real numbers x and y is 11. Their difference is 5. What is the value of xy ?

- F. 3
- G. 5
- H. 8
- J. 24
- K. 55

16. Solve absolute value equations or inequalities

The diameter, d centimeters, of the metal poles Goodpole Manufacturing produces must satisfy the inequality $|d - 3| \leq 0.001$. What is the maximum diameter, in centimeters, such a metal pole may have?

- F. 1.4995
- G. 1.5005
- H. 2.999
- J. 3.000
- K. 3.001

17. Use basic function notation to evaluate functions

If $f(x) = (3x + 7)^2$, then $f(1) = ?$

- A. 10
- B. 16
- C. 58
- D. 79
- E. 100

18. Odd and even functions

A function f is an *odd* function if and only if $f(-x) = -f(x)$ for every value of x in the domain of f . One of the functions graphed in the standard (x,y) coordinate plane below is an odd function. Which one?

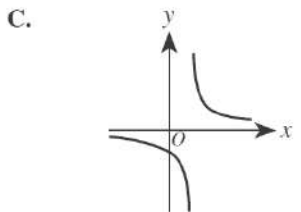
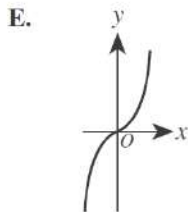
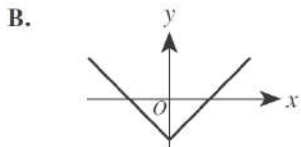
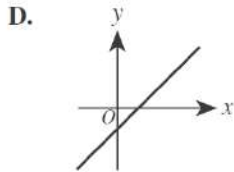
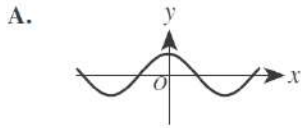
**19. Solve percent problems with variables**

Leticia went into Discount Music to price CDs. All CDs were discounted 23% off the marked price. Leticia wanted to program her calculator so she could input the marked price and the discounted price would be the output. Which of the following is an expression for the discounted price on a marked price of p dollars?

- A. $p - 0.23p$
- B. $p - 0.23$
- C. $p - 23p$
- D. $p - 23$
- E. $0.23p$

20. Simplify rational expressions

For all x in the domain of the function $\frac{x+1}{x^3-x}$, this function is equivalent to:

- F. $\frac{1}{x^2} - \frac{1}{x^3}$
- G. $\frac{1}{x^3} - \frac{1}{x}$
- H. $\frac{1}{x^2-1}$
- J. $\frac{1}{x^2-x}$
- K. $\frac{1}{x^3}$

Session 2

Algebra 2 Skills Checklist

1. Matrix operations

Given that $a \begin{bmatrix} 2 & 6 \\ 1 & 4 \end{bmatrix} = \begin{bmatrix} x & 27 \\ y & z \end{bmatrix}$ for some real number a , what is $x + z$?

- A. $\frac{4}{3}$
- B. $\frac{27}{2}$
- C. 26
- D. 27
- E. 48

2. Complex number operations

What is the product of the complex numbers $(-3i + 4)$ and $(3i + 4)$?

- A. 1
- B. 7
- C. 25
- D. $-7 + 24i$
- E. $7 + 24i$

3. Solve for x in an exponent

In the real numbers, what is the solution of the equation $8^{2x+1} = 4^{1-x}$?

- A. $-\frac{1}{3}$
- B. $-\frac{1}{4}$
- C. $-\frac{1}{8}$
- D. 0
- E. $\frac{1}{7}$

4. Exponential functions

For a population that grows at a constant rate of $r\%$ per year, the formula $P(t) = p_0 \left(1 + \frac{r}{100}\right)^t$ models the population t years after an initial population of p_0 people is counted.

The population of the city of San Jose was 782,000 in 1990. Assume the population grows at a constant rate of 5% per year. According to this formula, which of the following is an expression for the population of San Jose in the year 2000?

- A. $782,000(6)^{10}$
- B. $782,000(1.5)^{10}$
- C. $782,000(1.05)^{10}$
- D. $(782,000 \times 1.5)^{10}$
- E. $(782,000 \times 1.05)^{10}$

5. Geometric and arithmetic sequences and series

On the first day of school, Mr. Vilani gave his third-grade students 5 new words to spell. On each day of school after that, he gave the students 3 new words to spell. In the first 20 days of school, how many new words had he given the students to spell?

- A. 28
- B. 62
- C. 65
- D. 68
- E. 152

6. Recursive definitions of sequences

The n th term (t_n) of a certain sequence is defined as $t_n = t_{n-1} + 4$.

If $t_1 = -7$ then $t_{71} =$

- A. 273
- B. 277
- C. 281
- D. 283
- E. 287

7. Systems of inequalities

Tickets for the Senior Talent Show at George Washington Carver High School are \$3 for adults and \$2 for students. To cover expenses, a total of \$600 must be collected from ticket sales for the show. One of the following graphs in the standard (x,y) coordinate plane, where x is the number of adult tickets sold and y is the number of student tickets sold, represents all the possible combinations of ticket sales that cover at least \$600 in expenses. Which graph is it?

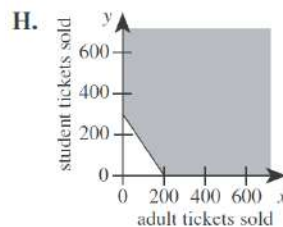
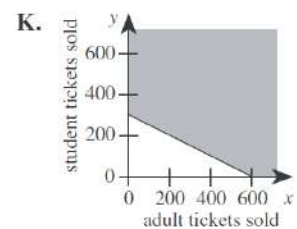
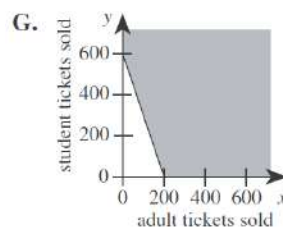
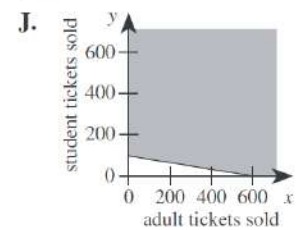
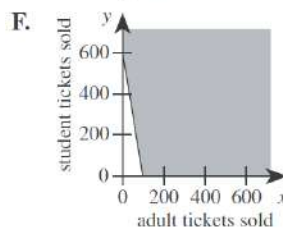

8. Compositions of functions

Consider the functions $f(x) = \sqrt{x}$ and $g(x) = 7x + b$. In the standard (x,y) coordinate plane, $y = f(g(x))$ passes through $(4,6)$. What is the value of b ?

- A. 8
- B. -8
- C. -25
- D. -26
- E. $4 - 7\sqrt{6}$

9. Trigonometric values on a unit circle

What is $\cos \frac{\pi}{12}$ given that $\frac{\pi}{12} = \frac{\pi}{3} - \frac{\pi}{4}$ and that $\cos(\alpha - \beta) = (\cos \alpha)(\cos \beta) + (\sin \alpha)(\sin \beta)$?

θ	$\sin \theta$	$\cos \theta$
$\frac{\pi}{6}$	$\frac{1}{2}$	$\frac{\sqrt{3}}{2}$
$\frac{\pi}{4}$	$\frac{\sqrt{2}}{2}$	$\frac{\sqrt{2}}{2}$
$\frac{\pi}{3}$	$\frac{\sqrt{3}}{2}$	$\frac{1}{2}$

- F. $\frac{1}{4}$
- G. $\frac{1}{2}$
- H. $\frac{\sqrt{6} + \sqrt{2}}{4}$
- J. $\frac{\sqrt{3} + \sqrt{2}}{2}$
- K. $\frac{\sqrt{6} + 2}{4}$

10. Graphs of trigonometric functions

The equations of the 2 graphs shown below are $y_1(t) = a_1 \sin(b_1 t)$ and $y_2(t) = a_2 \cos(b_2 t)$, where the constants b_1 and b_2 are both positive real numbers.

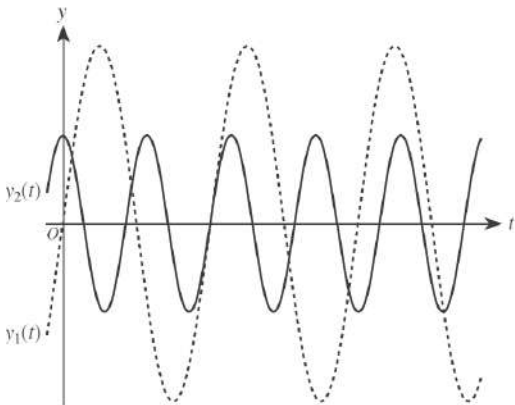

Which of the following statements is true of the constants a_1 and a_2 ?

- A. $0 < a_1 < a_2$
- B. $0 < a_2 < a_1$
- C. $a_1 < 0 < a_2$
- D. $a_1 < a_2 < 0$
- E. $a_2 < a_1 < 0$

11. Trigonometric identities

For x such that $0 < x < \frac{\pi}{2}$, the expression

$$\frac{\sqrt{1 - \cos^2 x}}{\sin x} + \frac{\sqrt{1 - \sin^2 x}}{\cos x}$$

is equivalent to:

- F. 0
- G. 1
- H. 2
- J. $-\tan x$
- K. $\sin 2x$

12. Simplifying or solve expressions and equations with logarithms

What is the real value of x in the equation $\log_2 24 - \log_2 3 = \log_5 x$?

- F. 3
- G. 21
- H. 72
- J. 125
- K. 243

13. Graphing Quadratic functions, identifying the vertex

The equation $y = x^2$ is graphed in the standard (x,y) coordinate plane. In which of the following equations is the graph of the parabola shifted 4 units to the left and 2 units up?

- A. $y = (x - 4)^2 + 2$
- B. $y = (x - 4)^2 - 2$
- C. $y = (x - 2)^2 + 4$
- D. $y = (x + 4)^2 + 2$
- E. $y = (x + 4)^2 - 2$

14. Graphs of systems of equations

The graphs of the equations $y = x - 1$ and $y = (x - 1)^4$ are shown in the standard (x, y) coordinate plane below. What real values of x , if any, satisfy the inequality $(x - 1)^4 < (x - 1)$?

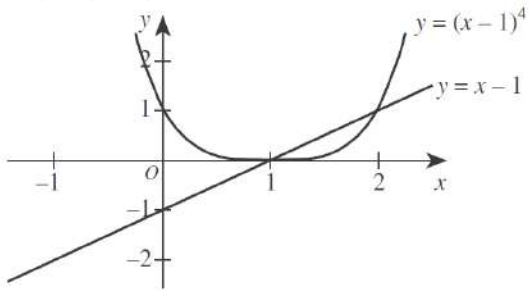

- A. No real values
- B. $x < 0$ and $x > 1$
- C. $x < 1$ and $x > 2$
- D. $0 < x < 1$
- E. $1 < x < 2$

15. Law of sines and law of cosines

The sides of an acute triangle measure 14 cm, 18 cm, and 20 cm, respectively. Which of the following equations, when solved for θ , gives the measure of the smallest angle of the triangle?

(Note: For any triangle with sides of length a , b , and c that are opposite angles A , B , and C , respectively, $\frac{\sin A}{a} = \frac{\sin B}{b} = \frac{\sin C}{c}$ and $c^2 = a^2 + b^2 - 2ab \cos C$.)

- F. $\frac{\sin \theta}{14} = \frac{1}{18}$
- G. $\frac{\sin \theta}{14} = \frac{1}{20}$
- H. $\frac{\sin \theta}{20} = \frac{1}{14}$
- J. $14^2 = 18^2 + 20^2 - 2(18)(20)\cos \theta$
- K. $20^2 = 14^2 + 18^2 - 2(14)(18)\cos \theta$

Algebra 1 and Algebra 2 Practice Problems

1.

Students studying motion observed a cart rolling at a constant rate along a straight line. The table below gives the distance, d feet, the cart was from a reference point at 1-second intervals from $t = 0$ seconds to $t = 5$ seconds.

t	0	1	2	3	4	5
d	14	20	26	32	38	44

Which of the following equations represents this relationship between d and t ?

- A. $d = t + 14$
- B. $d = 6t + 8$
- C. $d = 6t + 14$
- D. $d = 14t + 6$
- E. $d = 34t$

2.

An artist makes a profit of $(500p - p^2)$ dollars from selling p paintings. What is the fewest number of paintings the artist can sell to make a profit of at least \$60,000?

- F. 100
- G. 150
- H. 200
- J. 300
- K. 600

3.



Which of the following is the solution statement for the inequality shown below?

$$-5 < 1 - 3x < 10$$

- F. $-5 < x < 10$
- G. $-3 < x$
- H. $-3 < x < 2$
- J. $-2 < x < 3$
- K. $x < -3$ or $x > 2$

4.

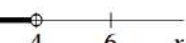
Which of the following number line graphs shows the solution set to the inequality $|x - 5| < -1$?

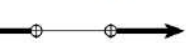
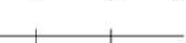
- F. 
- G. 
- H. 
- J. 
- K. 
(empty set)

5.

What are the real solutions to the equation

$$|x|^2 + 2|x| - 3 = 0?$$

- F. ± 1
- G. ± 3
- H. 1 and 3
- J. -1 and -3
- K. ± 1 and ± 3

6.

A function P is defined as follows:

$$\begin{aligned} \text{for } x > 0, P(x) &= x^5 + x^4 - 36x - 36 \\ \text{for } x < 0, P(x) &= -x^5 + x^4 + 36x - 36 \end{aligned}$$

What is the value of $P(-1)$?

- A. -70
- B. -36
- C. 0
- D. 36
- E. 70

7.

The expression $(4z + 3)(z - 2)$ is equivalent to:

- F. $4z^2 - 5$
- G. $4z^2 - 6$
- H. $4z^2 - 3z - 5$
- J. $4z^2 - 5z - 6$
- K. $4z^2 + 5z - 6$

8.

The first term is 1 in the geometric sequence 1, -3, 9, -27, What is the SEVENTH term of the geometric sequence?

- A. -243
- B. -30
- C. 81
- D. 189
- E. 729

9.

Which of the following is the graph of the region $1 < x + y < 2$ in the standard (x, y) coordinate plane?

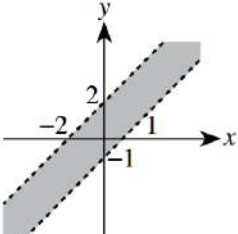
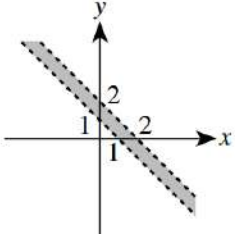
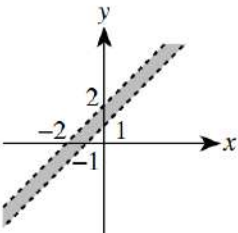
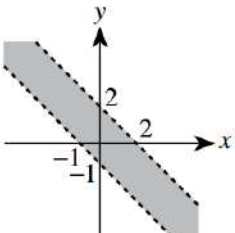
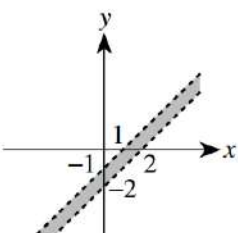
- F. 
- J. 
- G. 
- K. 
- H. 

10.

Which of the following describes a true relationship between the functions $f(x) = (x - 3)^2 + 2$ and $g(x) = \frac{1}{2}x + 1$ graphed below in the standard (x, y) coordinate plane?

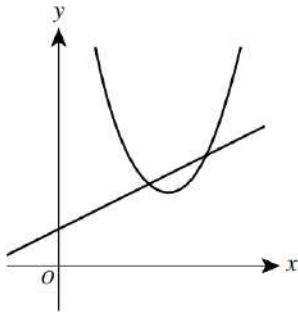

- F. $f(x) = g(x)$ for exactly 2 values of x
- G. $f(x) = g(x)$ for exactly 1 value of x
- H. $f(x) < g(x)$ for all x
- J. $f(x) > g(x)$ for all x
- K. $f(x)$ is the inverse of $g(x)$

11.

Given $f(x) = x - \frac{1}{x}$ and $g(x) = \frac{1}{x}$, what is $f\left(g\left(\frac{1}{2}\right)\right)$?

- F. -3
- G. $-\frac{3}{2}$
- H. $-\frac{2}{3}$
- J. 0
- K. $\frac{3}{2}$

12.

The shaded region in the graph below represents the solution set to which of the following systems of inequalities?

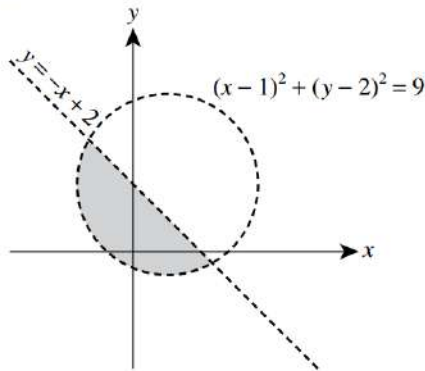

- A. $\begin{cases} y < -x + 2 \\ (x - 1)^2 + (y - 2)^2 < 9 \end{cases}$
- B. $\begin{cases} y > -x + 2 \\ (x - 1)^2 + (y - 2)^2 < 9 \end{cases}$
- C. $\begin{cases} y > -x + 2 \\ (x - 1)^2 + (y - 2)^2 > 9 \end{cases}$
- D. $\begin{cases} y < -x + 2 \\ (x - 1)^2 + (y - 2)^2 > 9 \end{cases}$
- E. $\begin{cases} (y - 2) < 3 \\ (x - 1) > 3 \end{cases}$

13.

The functions $y = \sin x$ and $y = \sin(x + a) + b$, for constants a and b , are graphed in the standard (x, y) coordinate plane below. The functions have the same maximum value. One of the following statements about the values of a and b is true. Which statement is it?

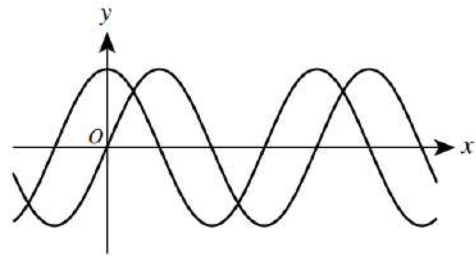

- A. $a < 0$ and $b = 0$
- B. $a < 0$ and $b > 0$
- C. $a = 0$ and $b > 0$
- D. $a > 0$ and $b < 0$
- E. $a > 0$ and $b > 0$

14.

Daisun owns 2 sportswear stores (X and Y). She stocks 3 brands of T-shirts (A, B, and C) in each store. The matrices below show the numbers of each type of T-shirt in each store and the cost for each type of T-shirt. The value of Daisun's T-shirt inventory is computed using the costs listed. What is the total value of the T-shirt inventory for Daisun's 2 stores?

	A	B	C	Cost
X	100	200	150	A \$ 5
Y	120	50	100	B \$10
				C \$15

- A. \$2,200
- B. \$2,220
- C. \$4,965
- D. \$5,450
- E. \$7,350

15.

A formula used to compute the current value of a savings account is $A = P(1 + r)^n$, where A is the current value; P is the amount deposited; r is the rate of interest for 1 compounding period, expressed as a decimal; and n is the number of compounding periods. Which of the following is closest to the value of a savings account after 5 years if \$10,000 is deposited at 4% annual interest compounded yearly?

- F. \$10,400
- G. \$12,167
- H. \$42,000
- J. \$52,000
- K. \$53,782

Science Sample Passage - Scientific Investigation

Passage I

Researchers studied how diet and the ability to smell food can affect the life span of normal fruit flies (Strain N) and fruit flies unable to detect many odors (Strain X).

Study 1

Three tubes (Tubes 1–3), each with 15% sugar yeast (SY) medium (a diet with 15% sugar and 15% killed yeast), were prepared. Then, 200 virgin female Strain N fruit flies less than 24 hr old were added to each tube. No additional substance was added to Tube 1. Additional odors from live yeast were added to Tube 2, and live yeast was added to Tube 3. The percent of fruit flies alive was determined every 5 days for 75 days (see Figure 1).

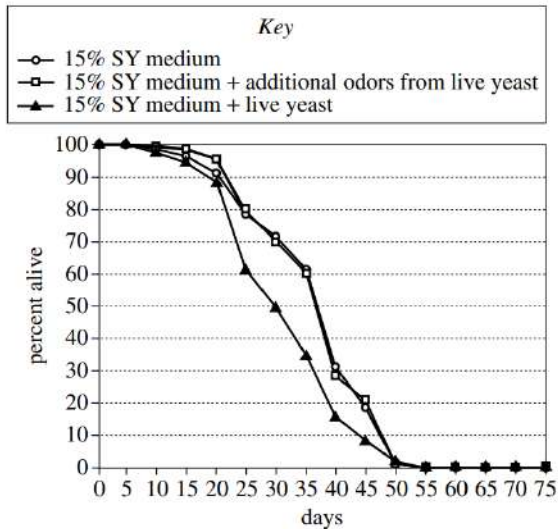

Figure 1

Study 2

Three tubes (Tubes 4–6), each with 5% SY medium (a diet with 5% sugar and 5% killed yeast), were prepared. Then, 200 virgin female Strain N fruit flies less than 24 hr old were added to each tube. No additional substance was added to Tube 4. Additional odors from live yeast were added to Tube 5, and live yeast was added to Tube 6. The percent of fruit flies alive was determined every 5 days for 75 days (see Figure 2).

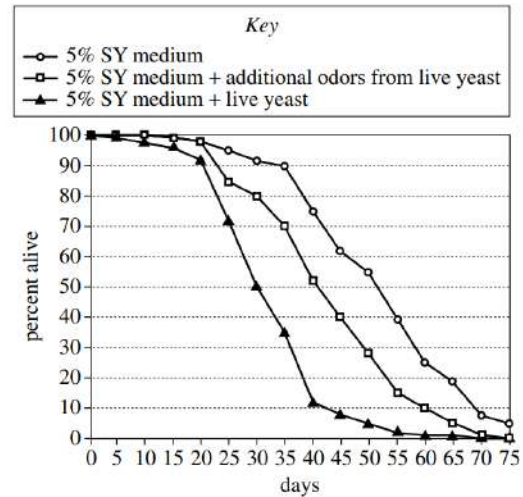

Figure 2

Study 3

Strain N fruit flies were modified to produce Strain X fruit flies. Strain X fruit flies lack *Or83b* (a protein required to detect a wide range of odors); therefore, they cannot detect many odors. The average life span was determined for virgin female Strain N and virgin female Strain X fruit flies fed with various SY media (see Table 1).

Strain	SY medium		Average life span (days)
	% sugar	% killed yeast	
Strain N	3	3	50.1
	5	5	50.1
	7.5	7.5	43.9
	10	10	44.8
	15	15	41.6
Strain X	3	3	61.6
	5	5	62.5
	7.5	7.5	58.9
	10	10	58.6
	15	15	55.6

- In which of Studies 1 and 2 did some of the fruit flies live for more than 75 days, and what diet were those fruit flies fed?
 - Study 1; 5% SY medium
 - Study 1; 15% SY medium
 - Study 2; 5% SY medium
 - Study 2; 15% SY medium
- During Studies 1 and 2, why did the size of the fruit fly population in each tube decrease rather than increase?
 - The birthrate was 0, because the initial population contained only males.
 - The birthrate was 0, because the initial population contained only virgin females.
 - The death rate was 0, because the initial population contained only males.
 - The death rate was 0, because the initial population contained only virgin females.

3. Study 1 differed from Study 2 in which of the following ways?
- A. Female fruit flies were tested in Study 1, whereas male fruit flies were tested in Study 2.
 - B. Male fruit flies were tested in Study 1, whereas female fruit flies were tested in Study 2.
 - C. The SY medium tested in Study 1 contained a lower percent of sugar than did the SY medium tested in Study 2.
 - D. The SY medium tested in Study 1 contained a higher percent of sugar than did the SY medium tested in Study 2.
4. Suppose that an additional trial in Study 3 had been performed using a 12% SY medium (a diet with 12% sugar and 12% killed yeast). The average life span of the Strain X fruit flies in this trial would most likely have been:
- F. less than 55.6 days.
 - G. between 55.6 days and 58.6 days.
 - H. between 58.6 days and 61.6 days.
 - J. greater than 61.6 days.
5. The researchers had predicted that decreasing a fruit fly's ability to detect odors would increase its life span. Are the results of Study 3 consistent with this prediction?
- A. No; for each SY medium tested, the average life span of Strain X fruit flies was longer than the average life span of Strain N fruit flies.
 - B. No; for each SY medium tested, the average life span of Strain N fruit flies was longer than the average life span of Strain X fruit flies.
 - C. Yes; for each SY medium tested, the average life span of Strain X fruit flies was longer than the average life span of Strain N fruit flies.
 - D. Yes; for each SY medium tested, the average life span of Strain N fruit flies was longer than the average life span of Strain X fruit flies.
6. Suppose the researchers wanted to determine whether a defect in the ability to detect odors would change the life span of fruit flies fed 15% SY medium when live yeast is added to the diet or when additional odors from live yeast are added to the diet. Which of the following experiments should be performed?
- F. Repeat Study 1 except with Strain X fruit flies
 - G. Repeat Study 1 except with Strain N fruit flies
 - H. Repeat Study 2 except with Strain X fruit flies
 - J. Repeat Study 2 except with Strain N fruit flies
7. The results for which 2 tubes should be compared to determine how a reduced calorie diet affects life span in the absence of live yeast and additional odors from live yeast?
- A. Tube 1 and Tube 4
 - B. Tube 1 and Tube 2
 - C. Tube 2 and Tube 5
 - D. Tube 5 and Tube 6

Practice Science Passages - Scientific Investigation

Passage V

A typical *acid-base indicator* is a compound that will be one color over a certain lower pH range but will be a different color over a certain higher pH range. In the small range between these pH ranges—the *transition range*—the indicator's color will be an intermediate of its other 2 colors.

Students studied 5 acid-base indicators using colorless aqueous solutions of different pH and a *well plate* (a plate containing a matrix of round depressions—*wells*—that can hold small volumes of liquid).

Experiment 1

The students added a pH = 0 solution to 5 wells in the first column of the well plate, then added a pH = 1 solution to the 5 wells in the next column, and so on, up to pH = 7. Next, they added a drop of a given indicator (in solution) to each of the wells in a row, and then repeated this process, adding a different indicator to each row. The color of the resulting solution in each well was then recorded in Table 1 (B = blue, G = green, O = orange, P = purple, R = red, Y = yellow).

Indicator	Color in solution with a pH of:							
	0	1	2	3	4	5	6	7
Metanil yellow	R	R	O	Y	Y	Y	Y	Y
Resorcin blue	R	R	R	R	R	P	P	B
Curcumin	Y	Y	Y	Y	Y	Y	Y	Y
Hessian bordeaux	B	B	B	B	B	B	B	B
Indigo carmine	B	B	B	B	B	B	B	B

Experiment 2

Experiment 1 was repeated with solutions that had a pH of 8 or greater (see Table 2).

Indicator	Color in solution with a pH of:						
	8	9	10	11	12	13	14
Metanil yellow	Y	Y	Y	Y	Y	Y	Y
Resorcin blue	B	B	B	B	B	B	B
Curcumin	O	R	R	R	R	R	R
Hessian bordeaux	B	R	R	R	R	R	R
Indigo carmine	B	B	B	B	G	Y	Y

Experiment 3

Students were given 4 solutions (Solutions I–IV) of unknown pH. The well plate was used to test samples of each solution with 4 of the 5 indicators (see Table 3).

Indicator	Color in Solution:			
	I	II	III	IV
Metanil yellow	Y	Y	Y	O
Resorcin blue	B	B	R	R
Curcumin	R	R	Y	Y
Indigo carmine	B	Y	B	B

27. One way Experiment 2 differed from Experiment 3 was that in Experiment 2:
- the solutions to which indicators were added were of known pH.
 - the solutions to which indicators were added were of unknown pH.
 - metanil yellow was used.
 - metanil yellow was not used.
28. Based on the description of the well plate and how it was used, the empty well plate would most likely have been which of the following colors?
- Black
 - Blue
 - Red
 - White
29. Based on the results of Experiments 1 and 2, which of the following is a possible transition range for curcumin?
- pH = 3.9 to pH = 7.3
 - pH = 4.2 to pH = 6.6
 - pH = 7.4 to pH = 8.6
 - pH = 8.4 to pH = 9.5
30. A chemist has 2 solutions, one of pH = 1 and one of pH = 6. Based on the results of Experiments 1 and 2, could indigo carmine be used to distinguish between these solutions?
- No; indigo carmine is blue at both pH = 1 and pH = 6.
 - No; indigo carmine is blue at pH = 1 and is yellow at pH = 6.
 - Yes; indigo carmine is blue at both pH = 1 and pH = 6.
 - Yes; indigo carmine is blue at pH = 1 and is yellow at pH = 6.
31. The indicator *propyl red* has a transition range of pH = 4.6 to pH = 6.8. If propyl red had been included in Experiments 1 and 2, it would have produced results most similar to those produced by which of the 5 indicators?
- Metanil yellow
 - Resorcin blue
 - Curcumin
 - Indigo carmine
32. A student claimed that Solution III has a pH of 7.3. Are the results of Experiments 1–3 consistent with this claim?
- No, because in Solution III metanil yellow was yellow.
 - No, because in Solution III resorcin blue was red.
 - Yes, because in Solution III metanil yellow was yellow.
 - Yes, because in Solution III resorcin blue was red.
33. Based on the results of Experiments 1–3, which of Solutions I–IV has the *lowest* pH?
- Solution I
 - Solution II
 - Solution III
 - Solution IV

Passage III

An electrical circuit contained a 12-volt (V) battery, a *resistor* (a device that resists the flow of electricity), a *capacitor* (a device that stores electrical charge and electrical energy), a *voltmeter* (an instrument for measuring voltage), and a switch, as shown in Figure 1.

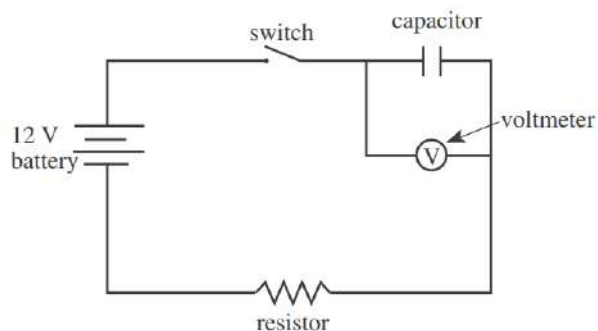

Figure 1

Some students studied the behavior of the circuit.

Experiment 1

The students used a 1×10^7 ohm (Ω) resistor and a capacitor with a *capacitance* of 1×10^{-6} farad (F). (Capacitance is a measure of the maximum amount of electrical charge and electrical energy a capacitor can store.) The capacitor was initially uncharged. At time zero, the students simultaneously closed the switch and started a stopwatch. At time zero and at 12 sec intervals thereafter, they recorded the voltage across the capacitor. Their results are shown in Table 1.

Time (sec)	Voltage across capacitor (V)
0	0.0
12	8.4
24	10.9
36	11.7
48	11.9
60	12.0

Experiment 2

Using the 1×10^7 Ω resistor and several different capacitors, the students determined the length of time from when the switch was closed until the voltage across the capacitor reached 6 V. Their results are shown in Table 2.

Capacitance ($\times 10^{-6}$ F)	Time to reach 6 V across capacitor (sec)
1.2	8.3
0.6	4.2
0.3	2.1
0.1	0.7

Experiment 3

The students conducted the same procedure described in Experiment 2, except that they used a constant capacitance of 1×10^{-6} F and several different resistors. Their results are shown in Table 3.

Resistance ($\times 10^7$ Ω)	Time to reach 6 V across capacitor (sec)
0.75	5.2
0.50	3.5
0.25	1.7

14. In Experiment 1, the *time constant* of the circuit was the time required for the voltage across the capacitor to reach approximately 7.6 V. The time constant of the circuit used in Experiment 1 was:
- F. less than 12 sec.
 - G. between 12 sec and 24 sec.
 - H. between 24 sec and 36 sec.
 - J. greater than 36 sec.
15. If, in Experiment 2, a 1.5×10^{-6} F capacitor had been used, the time required for the voltage across the capacitor to reach 6 V would have been closest to:
- A. 4.2 sec.
 - B. 7.0 sec.
 - C. 10.5 sec.
 - D. 15.0 sec.
16. The main purpose of Experiment 3 was to determine how varying the:
- F. battery's voltage affected the resistor's resistance at a given time.
 - G. capacitor's capacitance affected the time required for the voltage across the capacitor to reach a set value.
 - H. capacitor's capacitance affected the voltage across the battery at a given time.
 - J. resistor's resistance affected the time required for the voltage across the capacitor to reach a set value.

17. Based on Figure 1, to measure the voltage across the resistor only, which of the following circuits should one use?

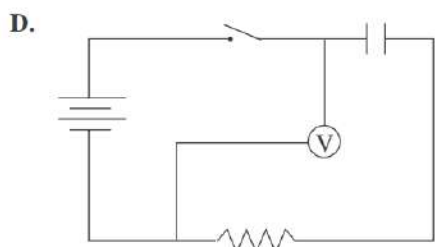
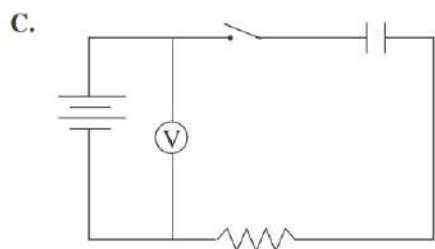
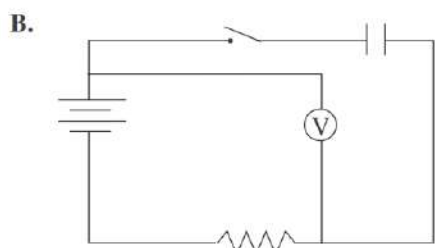
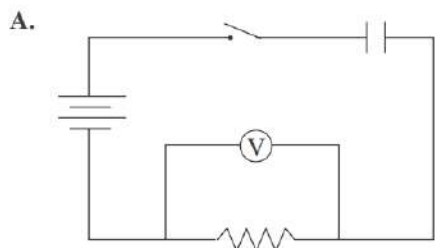

18. Consider a circuit like that shown in Figure 1. Based on Experiments 2 and 3, the voltage across the capacitor will reach a given value in the shortest amount of time if the circuit contains which of the following capacitances and resistances, respectively?

- F. 0.1×10^{-6} F, 0.3×10^7 Ω
- G. 0.1×10^{-6} F, 1.0×10^7 Ω
- H. 1.2×10^{-6} F, 0.3×10^7 Ω
- J. 1.2×10^{-6} F, 1.0×10^7 Ω

19. Consider the following hypothesis: In a circuit arranged as in Figure 1 containing a battery, a capacitor, and a constant resistance, as capacitance increases, the time required to reach a given voltage across the capacitor increases. Do the experiments support this hypothesis?

- A. Yes; in Experiment 1, as capacitance increased, the time required to reach a given voltage increased.
- B. Yes; in Experiment 2, as capacitance increased, the time required to reach a given voltage increased.
- C. No; in Experiment 1, as capacitance increased, the time required to reach a given voltage decreased.
- D. No; in Experiment 2, as capacitance increased, the time required to reach a given voltage decreased.

Session 3

Geometry Skills Checklist

1. Area and perimeter of polygons

In the 8-sided figure below, adjacent sides meet at right angles and the lengths given are in meters. What is the perimeter of the figure, in meters?

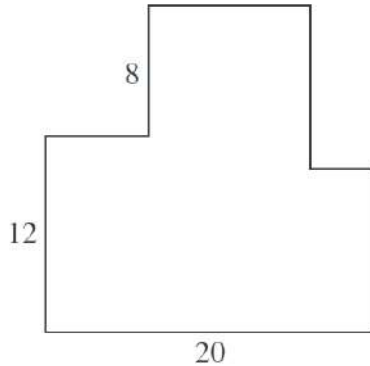

- A. 40
- B. 80
- C. 120
- D. 160
- E. 400

2. Pythagorean Theorem

What is the length, in feet, of the hypotenuse of a right triangle with legs that are 6 feet long and 7 feet long respectively?

- F. $\sqrt{13}$
- G. $\sqrt{85}$
- H. 13
- J. 21
- K. 42

3. Parallel lines and angle relationships

In the figure below, line l is parallel to line m . Transversals t and u intersect at point A on l and intersect m at points B and C , respectively. Point X is on m , the measure of $\angle ACX$ is 130° , and the measure of $\angle BAC$ is 80° . How many of the angles formed by rays of l , m , t , and u have measure 50° ?

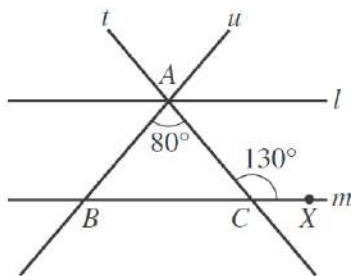

- A. 4
- B. 6
- C. 8
- D. 10
- E. 12

4. Interior and exterior angles of polygons

In the figure below, 2 nonadjacent sides of a regular pentagon (5 congruent sides and 5 congruent interior angles) are extended until they meet at point X . What is the measure of $\angle X$?

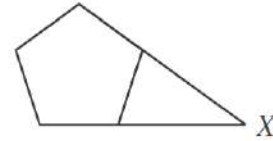

- A. 18°
- B. 30°
- C. 36°
- D. 45°
- E. 72°

5. Translations, reflections, and rotations of points and figures

Trapezoid $ABCD$ is graphed in the standard (x,y) coordinate plane below.

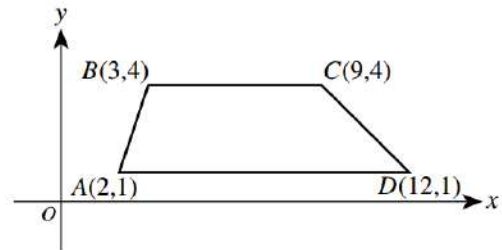

When $ABCD$ is reflected over the y -axis to $A'B'C'D'$, what are the coordinates of D' ?

- F. $(-12, 1)$
- G. $(-12, -1)$
- H. $(12, -1)$
- J. $(1, 12)$
- K. $(1, -12)$

6. Angles of triangles

In the figure below, A , D , B , and G are collinear. If $\angle CAD$ measures 76° , $\angle BCD$ measures 47° , and $\angle CBG$ measures 140° , what is the degree measure of $\angle ACD$?

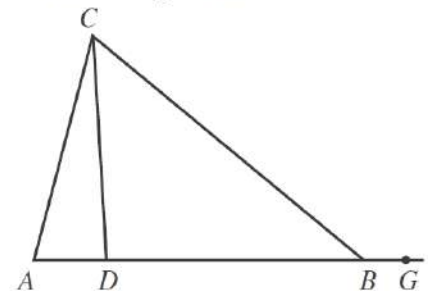

- F. 12°
- G. 14°
- H. 17°
- J. 36°
- K. 43°

7. Isosceles or equilateral triangles

The figure below is composed of square $BCDE$ and equilateral triangle $\triangle ABE$. The length of \overline{CD} is 6 inches. What is the perimeter of $ABCDE$, in inches?

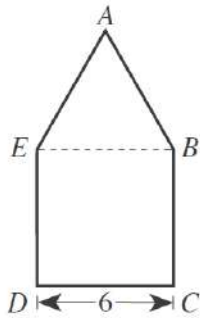

- A. 18
- B. 24
- C. 30
- D. 42
- E. 45

8. Area and circumference of circles

Meg pounded a stake into the ground. When she attached a leash to both the stake and her dog's collar, the dog could reach 9 feet from the stake in any direction. Using 3.14 for π , what is the approximate area of the lawn, in square feet, the dog could reach from the stake?

- A. 28
- B. 57
- C. 113
- D. 254
- E. 283

9. Right triangle trigonometric relationships as ratios

Which of the following trigonometric equations is valid for the side measurement x inches, diagonal measurement y inches, and angle measurement w° in the rectangle shown below?

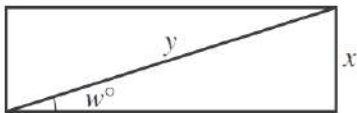

- A. $\cos w^\circ = \frac{x}{y}$
- B. $\cot w^\circ = \frac{x}{y}$
- C. $\sec w^\circ = \frac{x}{y}$
- D. $\sin w^\circ = \frac{x}{y}$
- E. $\tan w^\circ = \frac{x}{y}$

10. Solve right triangles using trigonometry

In $\triangle ABD$, shown below, C is on \overline{BD} , the length of \overline{AD} is 6 inches, and $\sin d = 0.8$. How many inches long is \overline{CD} ?

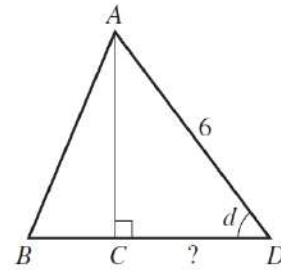

- F. 1.2
- G. 1.8
- H. 3.6
- J. 4.8
- K. Cannot be determined from the given information

11. Special right triangles (30-60-90 and 45-45-90)

What is the perimeter, in inches, of the isosceles right triangle shown below, whose hypotenuse is $8\sqrt{2}$ inches long?

- A. 8
- B. $8 + 8\sqrt{2}$
- C. $8 + 16\sqrt{2}$
- D. 16
- E. $16 + 8\sqrt{2}$

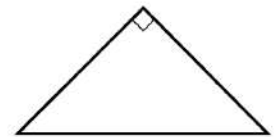

12. Triangle inequalities

For all triangles $\triangle XYZ$ where side \overline{XZ} is longer than side \overline{YZ} , such as the triangle shown below, which of the following statements is true?

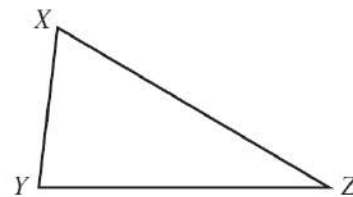

- F. The measure of $\angle X$ is always less than the measure of $\angle Y$.
- G. The measure of $\angle X$ is always equal to the measure of $\angle Y$.
- H. The measure of $\angle X$ is always greater than the measure of $\angle Y$.
- J. The measure of $\angle X$ is sometimes less than the measure of $\angle Y$ and sometimes equal to the measure of $\angle Y$.
- K. The measure of $\angle X$ is sometimes greater than the measure of $\angle Y$ and sometimes equal to the measure of $\angle Y$.

13. Finding a midpoint or missing endpoint

In the standard (x,y) coordinate plane, the midpoint of \overline{AB} is $(4,-3)$ and A is located at $(1,-5)$. If (x,y) are the coordinates of B , what is the value of $x + y$?

- A. 19
- B. 8
- C. 6
- D. -1.5
- E. -3

14. Finding the distance between two points

What is the distance in the standard (x,y) coordinate plane between the points $(5,5)$ and $(1,0)$?

- A. $\sqrt{26}$
- B. $\sqrt{41}$
- C. 4
- D. 6
- E. 16

15. Equations of parallel and perpendicular lines

Which of the following is the slope of a line parallel to the line $y = \frac{2}{3}x - 4$ in the standard (x,y) coordinate plane?

- A. -4
- B. $-\frac{3}{2}$
- C. 2
- D. $\frac{3}{2}$
- E. $\frac{2}{3}$

16. Reflections over the line $y = x$

A triangle, $\triangle ABD$, is reflected across the line $y = x$ to have the image $\triangle A'B'D'$ in the standard (x,y) coordinate plane: thus A reflects to A' . The coordinates of point A are (m,n) . What are the coordinates of point A' ?

- F. $(-m,n)$
- G. $(m,-n)$
- H. $(-m,-n)$
- J. (n,m)
- K. Cannot be determined from the given information.

17. Equations of circles, finding center and radius

The radio signal from the transmitter site of radio station WGGW can be received only within a radius of 52 miles in all directions from the transmitter site. A map of the region of coverage of the radio signal is shown below in the standard (x,y) coordinate plane, with the transmitter site at the origin and 1 coordinate unit representing 1 mile.

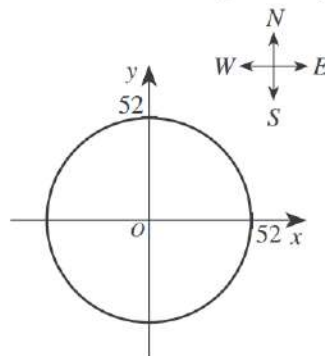

Which of the following is an equation of the circle shown on the map?

- A. $x + y = 52$
- B. $(x + y)^2 = 52$
- C. $(x + y)^2 = 52^2$
- D. $x^2 + y^2 = 52$
- E. $x^2 + y^2 = 52^2$

18. Areas and lengths of arcs

The figure below shows part of a circle whose circumference is 40. If arcs of length 4 and length s continue to alternate around the entire circle so that there are 8 arcs of each length, what is the degree measure of each of the arcs of length s ?

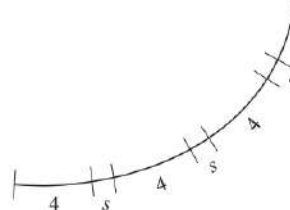

- F. 6°
- G. 9°
- H. 12°
- J. 18°
- K. 36°

19. Similarity and scale factors

In the figure below, where $\triangle ABC \sim \triangle KLM$, lengths given are in centimeters. What is the perimeter, in centimeters, of $\triangle ABC$?

(Note: The symbol \sim means “is similar to.”)

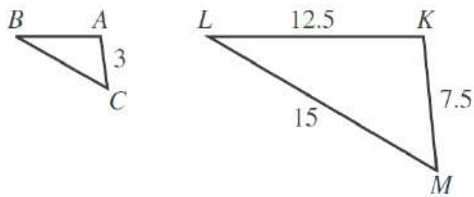

- A. 12
- B. 14
- C. $21\frac{1}{2}$
- D. 35
- E. $71\frac{3}{4}$

20. Ratios of sides, areas, and volumes

Cube A has an edge length of 2 inches. Cube B has an edge length double that of Cube A. What is the volume, in cubic inches, of Cube B?

- A. 4
- B. 8
- C. 16
- D. 32
- E. 64

21. Finding surface area and volume

The edges of a cube are each 3 inches long. What is the surface area, in square inches, of this cube?

- F. 9
- G. 18
- H. 27
- J. 36
- K. 54

22. Identify congruent parts of figures

In the figure below, \overline{AD} is perpendicular to \overline{BD} , \overline{AC} is perpendicular to \overline{BC} , and $\overline{AD} \cong \overline{BC}$. Which of the following congruences is NOT necessarily true?

- F. $\overline{AC} \cong \overline{BD}$
- G. $\overline{AD} \cong \overline{AE}$
- H. $\overline{AE} \cong \overline{BE}$
- J. $\angle DAB \cong \angle CBA$
- K. $\angle EAB \cong \angle EBA$

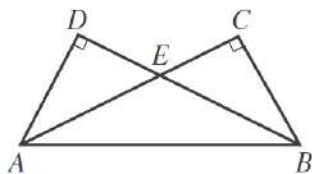

Geometry Practice Problems

1.

In the figure below, C is the intersection of \overline{AD} and \overline{BE} . If it can be determined, what is the measure of $\angle BAC$?

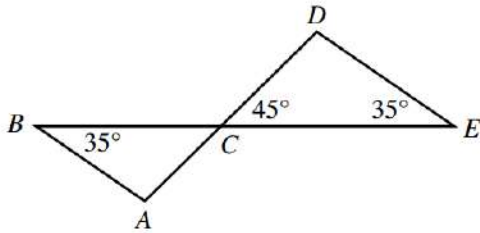

- A. 80°
- B. 100°
- C. 110°
- D. 115°
- E. Cannot be determined from the given information

2.

For trapezoid $ABCD$ shown below, $\overline{AB} \parallel \overline{DC}$, the measures of the interior angles are distinct, and the measure of $\angle D$ is x° . What is the degree measure of $\angle A$ in terms of x ?

- F. $(180 - x)^\circ$
- G. $(180 - 0.5x)^\circ$
- H. $(180 + 0.5x)^\circ$
- J. $(180 + x)^\circ$
- K. x°

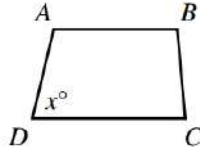

3.

The radius of the base of the right circular cone shown below is 5 inches, and the height of the cone is 7 inches. Solving which of the following equations gives the measure, θ , of the angle formed by a slant height of the cone and a radius?

- F. $\tan \theta = \frac{5}{7}$
- G. $\tan \theta = \frac{7}{5}$
- H. $\sin \theta = \frac{5}{7}$
- J. $\sin \theta = \frac{7}{5}$
- K. $\cos \theta = \frac{7}{5}$

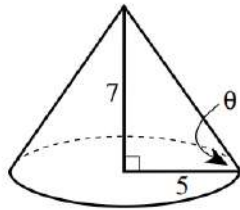

4.

The points $E(6,4)$ and $F(14,12)$ lie in the standard (x,y) coordinate plane shown below. Point D lies on \overline{EF} between E and F such that the length of \overline{EF} is 4 times the length of \overline{DE} . What are the coordinates of D ?

- F. $(7, 5)$
- G. $(8, 6)$
- H. $(8, 8)$
- J. $(10, 8)$
- K. $(12, 10)$

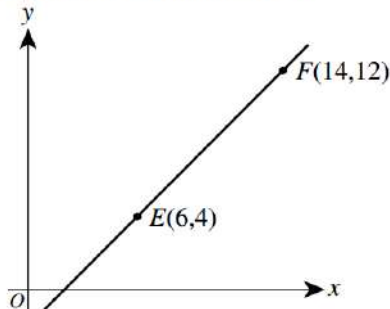

5.

A formula for the surface area (A) of the rectangular solid shown below is $A = 2lw + 2lh + 2wh$ where l represents length; w , width; and h , height. By doubling each of the dimensions (l , w , and h), the surface area will be multiplied by what factor?

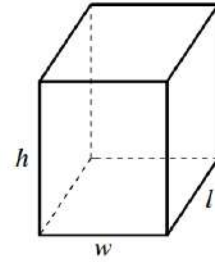

- A. 2
- B. 4
- C. 6
- D. 8
- E. 12

6.

Hexagon $ABCDEF$ shown below was drawn on a grid with unit squares. Each vertex is at the intersection of 2 grid lines. What is the area of the hexagon, in square units?

- A. 18
- B. 19
- C. 20
- D. 22
- E. 25

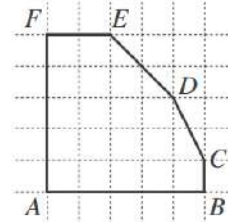

Use the following information for problems 7 and 8

The youth center has installed a swimming pool on level ground. The pool is a right circular cylinder with a diameter of 24 feet and a height of 6 feet. A diagram of the pool and its entry ladder is shown below.

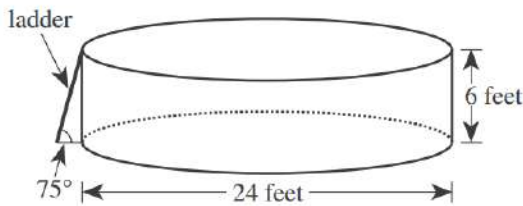

7.

A plastic cover is made for the pool. The cover will rest on the top of the pool and will include a wedge-shaped flap that forms a 45° angle at the center of the cover, as shown in the figure below. A zipper will go along 1 side of the wedge-shaped flap and around the arc. Which of the following is closest to the length, in feet, of the zipper?

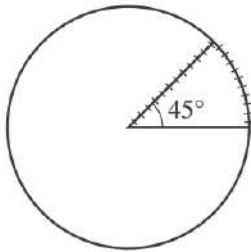

- F. 17
- G. 22
- H. 24
- J. 29
- K. 57

8.

The directions for assembling the pool state that the ladder should be placed at an angle of 75° relative to level ground. Which of the following expressions involving tangent gives the distance, in feet, that the bottom of the ladder should be placed away from the bottom edge of the pool in order to comply with the directions?

- F. $\frac{6}{\tan 75^\circ}$
- G. $\frac{\tan 75^\circ}{6}$
- H. $\frac{1}{6 \tan 75^\circ}$
- J. $6 \tan 75^\circ$
- K. $\tan(6 \cdot 75^\circ)$

9.

The parallel sides of the isosceles trapezoid shown below are 10 feet long and 16 feet long, respectively. What is the distance, in feet, between these 2 sides?

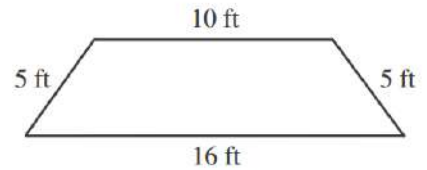

- A. 3
- B. 4
- C. 5
- D. 10
- E. 16

10.

For the triangles in the figure below, which of the following ratios of side lengths is equivalent to the ratio of the perimeter of $\triangle ABC$ to the perimeter of $\triangle DAB$?

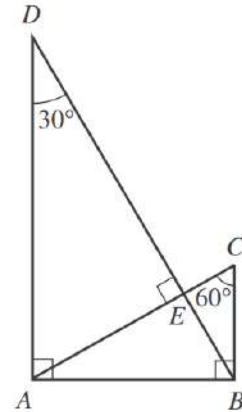

- F. $AB:AD$
- G. $AB:BD$
- H. $AD:BD$
- J. $BC:AD$
- K. $BC:BD$

Science Sample Passage - Evaluation of Models

Passage II

In the fall, monarch butterflies (*Danaus plexippus*) in eastern North America migrate to Mexico, where they overwinter in high-altitude forests of *oyamel fir* (an evergreen conifer). The butterflies store (accumulate) body lipids to use as a source of energy at a later time. Consider the following 3 hypotheses pertaining to when the butterflies store lipids and when the energy from the stored lipids is used, with respect to migration and overwintering.

Hypothesis 1

Monarch butterflies require energy from stored lipids for migration and during the overwintering period. The butterflies first store lipids before they begin their migration. During migration, as stored lipids are converted to energy, lipid mass continuously decreases. When the butterflies reach the overwintering sites, ending their migration, they must store lipids again before beginning the overwintering period.

Hypothesis 2

Monarch butterflies require energy from stored lipids for migration but not during the overwintering period. The butterflies store lipids before they begin their migration. During migration, as stored lipids are converted to energy, lipid mass continuously decreases. Because energy from stored lipids is not required during the overwintering period, the butterflies do not store lipids while at the overwintering sites.

Hypothesis 3

Monarch butterflies require energy from stored lipids during the overwintering period but not for migration. The butterflies do not store lipids before they begin their migration. Instead, lipids are stored during migration; therefore, lipid mass continuously increases from the beginning of migration until the end of migration. The butterflies arrive at the overwintering sites with enough lipids to provide themselves with energy during the overwintering period, so they do not store lipids while at the overwintering sites.

8. Which hypothesis, if any, asserts that monarch butterflies store lipids during 2 distinct periods?

F. Hypothesis 1
G. Hypothesis 2
H. Hypothesis 3
J. None of the hypotheses

9. Which hypothesis, if any, asserts that monarch butterflies require energy from stored lipids neither for migration nor during the overwintering period?

A. Hypothesis 1
B. Hypothesis 2
C. Hypothesis 3
D. None of the hypotheses

10. Based on Hypothesis 3, which of the following figures best depicts the change in the lipid mass of a monarch butterfly from the beginning of migration to the end of migration?

(Note: In each figure, B represents the beginning of migration and E represents the end of migration.)

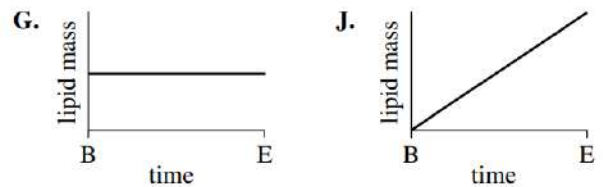
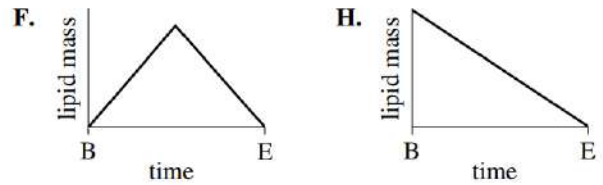

11. Assume that changes in the body mass of a monarch butterfly are caused only by changes in the mass of the butterfly's stored lipids. The statement "The percent of a monarch butterfly's body mass that is made up of lipids is greater at the beginning of migration than at the end of migration" is supported by which of the hypotheses?

A. Hypothesis 1 only
B. Hypothesis 2 only
C. Hypotheses 1 and 2 only
D. Hypotheses 1, 2, and 3

12. To store lipids, monarch butterflies convert sugar from nectar they have consumed into lipids. A supporter of which hypothesis, if any, would be likely to claim that to ensure the butterflies can store lipids for the overwintering period, nectar must be present at the butterflies' overwintering sites?

F. Hypothesis 1
G. Hypothesis 2
H. Hypothesis 3
J. None of the hypotheses

13. Which of the following statements about lipids in monarch butterflies is consistent with all 3 hypotheses?

A. The butterflies' lipid masses do not change during the overwintering period.
B. The butterflies' lipid masses change during migration.
C. The butterflies use energy from stored lipids during the overwintering period.
D. The butterflies use energy from stored lipids for migration.

14. When the monarch butterflies use their stored lipids, the lipids must be broken down to produce energy-rich molecules that can be readily used by cells. Which of the following molecules is produced as a direct result of the breakdown of the lipids?

F. ATP
G. Starch
H. DNA
J. Amino acids

Practice Science Passages - Evaluation of Models

Passage VII

In the 1940s, scientists thought all genetic material was contained in structures called *chromosomes* and that chromosomes had been found only in the nucleus of a cell (not in the cytoplasm):

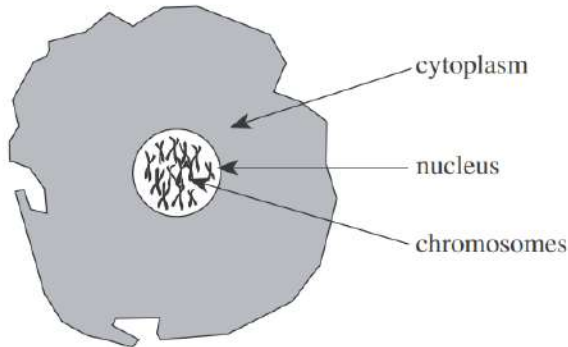

Chromosomes are composed of 2 types of molecules, proteins and deoxyribonucleic acid (DNA). Proteins are composed of subunits called *amino acids*. DNA consists of chains of subunits called *nucleotides*. The parts of chromosomes that are responsible for the transmission of genetic information are called *genes*.

Two scientists in the 1940s debate whether genes are made of proteins or DNA.

Protein Hypothesis

Genes are made only of proteins. Proteins make up 50% or more of a cell's dry weight. Cells contain 20 different amino acids that can be arranged in a virtually infinite number of ways to make different proteins. The number and arrangement of different amino acids within a protein form the codes that contain hereditary information.

In contrast, only 4 different nucleotides make up the DNA found in cells, and they are believed to form chains only in certain ratios. As a result, the number of different combinations that DNA can carry is much smaller than the number that proteins can carry.

DNA Hypothesis

Genes are made only of DNA. DNA is found exclusively in the cell's nucleus, whereas proteins are found throughout the nucleus and cytoplasm. Additionally, the amount of protein in a cell varies from cell type to cell type, even within the same animal.

Though DNA is less abundant than proteins, the amount is consistent from cell type to cell type within the same animal, except for the *gametes* (the reproductive cells). Gametes have half the amount of DNA as other cells in the body. Gametes also have half the typical number of chromosomes. Thus, the amount of DNA in a cell is correlated with the number of chromosomes in the cell. No such correlation is found for proteins.

34. Which of the following statements is most consistent with the DNA Hypothesis? The amount of DNA will generally increase from cell type to cell type as the number of:
- F. amino acids in the nucleus increases from cell type to cell type.
 - G. amino acids in the cytoplasm increases from cell type to cell type.
 - H. chromosomes in the nucleus increases from cell type to cell type.
 - J. chromosomes in the cytoplasm increases from cell type to cell type.
35. By referring to the observation that DNA is found exclusively in the nucleus while proteins are found throughout the cell, the scientist supporting the DNA Hypothesis implies that genes are made only of DNA because which of the following are also found only in the nucleus?
- A. Amino acids
 - B. Proteins
 - C. Gametes
 - D. Chromosomes
36. According to the passage, a similarity between DNA and proteins is that both types of molecules:
- F. are found only in gametes.
 - G. are abundant in the cytoplasm.
 - H. contain 20 different amino acids.
 - J. are composed of smaller subunits.
37. According to the Protein Hypothesis, which of the following observations provides the strongest evidence that genes are NOT composed of DNA ?
- A. DNA is composed of only 4 types of nucleotides.
 - B. DNA is composed of smaller subunits than are proteins.
 - C. DNA is abundant in both the nucleus and the cytoplasm.
 - D. The concentration of DNA is generally consistent from cell to cell.
38. *Mitochondria* are organelles located in the cytoplasm that are responsible for energy transformation in a cell. After the 1940s, it was observed that mitochondria contain their own genes. This observation contradicts evidence stated in which hypothesis?
- F. The DNA Hypothesis, because if genes are made of DNA, the observation would show that DNA is present outside the nucleus.
 - G. The DNA Hypothesis, because if genes are made of DNA, the observation would show that DNA is present inside the nucleus.
 - H. The Protein Hypothesis, because if genes are made of proteins, the observation would show that proteins are present outside the nucleus.
 - J. The Protein Hypothesis, because if genes are made of proteins, the observation would show that proteins are present inside the nucleus.

39. The scientist who describes the DNA Hypothesis implies that the Protein Hypothesis is *weakened* by which of the following observations?
- For a given organism, the amount of protein in the gametes is half that found in other types of cells.
 - For a given organism, the amount of protein in different types of cells is not the same.
 - Protein molecules are composed of many subunits.
 - Proteins are found only in the nucleus.
40. Which of the following illustrations of a portion of a DNA molecule is consistent with the description in the passage?

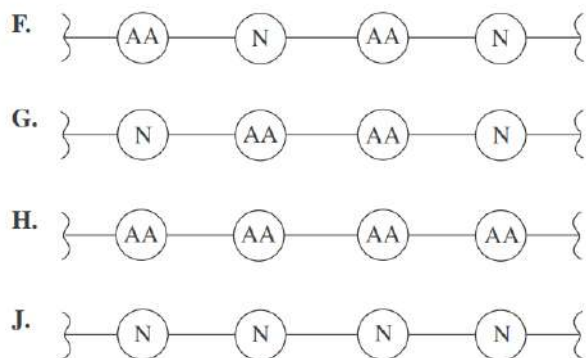
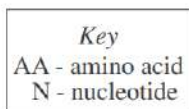

Passage II

In 1908, an object from outer space devastated 2,000 km² of forest in Siberia. The object was between 10 m and 100 m in diameter and traveled at a maximum speed of 15 km/sec. It exploded at an altitude of 8 km and released energy equivalent to 20 million tons of TNT. Two scientists discuss whether this object was a comet or an asteroid.

Scientist 1

The object was a comet, a body made of ices (such as frozen water or methane) and dust. Most of this cometary material is *volatile* (easily vaporized) and low in density. Friction in Earth's atmosphere heated the comet to a temperature at which it exploded, high above the ground. The majority of the ices and dust were vaporized in the explosion, which explains why no crater was formed at the site and why no large, identifiable fragments of the object were found. An asteroid would not have been completely destroyed. Intact asteroid fragments that reached the ground would have created one or more craters upon impact and left behind recoverable pieces. Evidence shows that the object decelerated rapidly before it exploded. Because of their low density, comets are capable of such rapid deceleration, whereas high-density objects, such as asteroids, are not.

Scientist 2

The object was a stony asteroid. As it entered Earth's atmosphere, its high speed created a large air pressure difference between the area just in front of the asteroid and the area just behind the asteroid. The large pressure difference eventually exceeded the structural strength of the asteroid. The asteroid flattened, decelerated rapidly due to the dramatic increase in its surface area, and fragmented before reaching the ground. This fragmentation would have appeared like an explosion. Calculations show that a comet between 10 m and 100 m in diameter would explode at an altitude much higher than 8 km, but a stony asteroid of that size would fragment at or near an altitude of 8 km. Recovery of large asteroid fragments is difficult due to the area's boggy soil; however, small, glassy fragments were recovered and are believed to be melted and resolidified pieces of the asteroid.

6. Which of the following phrases best describes the major point of difference between the 2 scientists' hypotheses?
- The location of the event
 - The speed the object was traveling
 - The density of Earth's atmosphere
 - The type of object that entered Earth's atmosphere
7. According to Scientist 2's viewpoint, compared to the altitude at which a stony asteroid would have exploded in Earth's atmosphere, a comet of similar size would most likely have exploded at:
- the same altitude.
 - a higher altitude.
 - a slightly lower altitude.
 - a much lower altitude.
8. Scientist 1's viewpoint indicates that when the materials that compose most of a comet are sufficiently heated, they change to:
- solids.
 - gases.
 - liquids.
 - a vacuum.
9. Which of the following statements best describes how Scientist 2 would explain why no large, identifiable fragments of the object have been recovered?
- Any large, identifiable fragments that reached the ground have been removed from the area by erosion.
 - Any large, identifiable fragments were thrown hundreds of kilometers from the site.
 - No large, identifiable fragments of the object reached the ground.
 - No large, identifiable fragments of the object have been recovered due to the soil conditions in the area.
10. How would the behavior of the asteroid differ from that described in Scientist 2's viewpoint if the asteroid had not been flattened by the air pressure difference? The asteroid would:
- not have entered Earth's atmosphere.
 - have struck another planet in the solar system.
 - have decelerated more gradually.
 - have frozen.

11. Which of the following statements would both scientists most likely use to explain the damage to the forest caused by the object's explosion? Energy from the explosion:
- A. traveled rapidly down to Earth's surface.
 - B. dissipated in the upper atmosphere.
 - C. was released less than 1 km above Earth's surface.
 - D. was released as the object struck Earth's surface.
12. Scientist 1's viewpoint would be *weakened* by which of the following observations about comets, if true?
- F. Comets are composed mainly of frozen materials.
 - G. Comets are much larger than 100 m in diameter.
 - H. Comets often pass close enough to Earth to intersect Earth's atmosphere.
 - J. Comets orbit the Sun.

Session 4

Statistics and Probability Skills Checklist

1. Find average or weighted average

To determine a student's overall test score for the semester, Ms. Lopez throws out the lowest test score and takes the average of the remaining test scores. Victor earned the following test scores in Ms. Lopez's class this semester: 62, 78, 83, 84, and 93. What overall test score did Victor earn in Ms. Lopez's class this semester?

- A. 67.6
- B. 80.0
- C. 83.0
- D. 83.5
- E. 84.5

2. Find missing value given an average

Tom has taken 5 of the 8 equally weighted tests in his U.S. History class this semester, and he has an average score of exactly 78.0 points. How many points does he need to earn on the 6th test to bring his average score up to exactly 80.0 points?

- A. 90
- B. 88
- C. 82
- D. 80
- E. 79

3. Use data from a table, graph, or chart to answer questions

The table below shows the price of different quantities of standard-sized lemons at Joe's Fruit Stand. What is the least amount of money needed to purchase exactly 20 standard-sized lemons if the bags must be sold intact and there is no tax charged for lemons?

Number of lemons:	1	bag of 6	bag of 12
Total price:	\$0.30	\$1.20	\$2.10

- A. \$3.60
- B. \$3.90
- C. \$4.20
- D. \$4.50
- E. \$6.00

4. Basic probability of independent events and their complements

A bag contains 6 red marbles, 5 yellow marbles, and 7 green marbles. How many additional red marbles must be added to the 18 marbles already in the bag so that the probability of randomly drawing a red marble is $\frac{3}{5}$?

- F. 12
- G. 16
- H. 18
- J. 24
- K. 36

5. Compute probabilities of multiple events

All 100 seniors at City High School who are enrolled in either calculus, statistics, or both. If 75 seniors are enrolled in calculus and 50 are enrolled in statistics, what is the probability that a randomly chosen senior is enrolled in both calculus and statistics?

- F. $\frac{1}{8}$
- G. $\frac{3}{16}$
- H. $\frac{1}{4}$
- J. $\frac{1}{2}$
- K. Cannot be determined from the information given.

6. Counting problems

How many different positive three-digit integers can be formed if the three digits 3, 4, and 5 must be used in each of the integers?

- F. 6
- G. 8
- H. 12
- J. 15
- K. 24

7. Find measures of sectors in circle graphs

Antwan drew the circle graph below describing his time spent at school in 1 day. His teacher said that the numbers of hours listed were correct, but that the central angle measures for the sectors were not correct. What should be the central angle measure for the Core subjects sector?

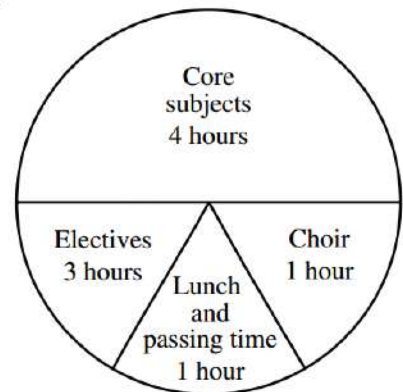

- F. 72°
- G. 80°
- H. 160°
- J. 200°
- K. 288°

8. Two-way frequency tables

	For	Against	No opinion	Total
21 - 40	25	20	5	50
41 - 60	20	35	20	75
Over 60	55	15	5	75
Total	100	70	30	200

Frequency Count

A public opinion survey explored the relationship between age and support for increasing the minimum wage. The results are summarized in the two-way table to the right.

In the 21 to 40 age group, what percentage supports increasing the minimum wage?

- (A) 12.5%
- (B) 20%
- (C) 25%
- (D) 50%
- (E) 75%

9. Conditional and joint probabilities

To get a driver's license, an applicant must pass a written test and a driving test. Past records show that 80% of the applicants pass the written test and 60% of those who have passed the written test pass the driving test. Based on these figures, how many applicants in a random group of 1,000 applicants would you expect to get driver's licenses?

- A. 200
- B. 480
- C. 600
- D. 750
- E. 800

10. Find and compare mean, median and mode

What is the difference between the mean and the median of the set {3, 8, 10, 15} ?

- A. 0
- B. 1
- C. 4
- D. 9
- E. 12

Statistics Practice Problems

1.

The blood types of 150 people were determined for a study as shown in the figure below.

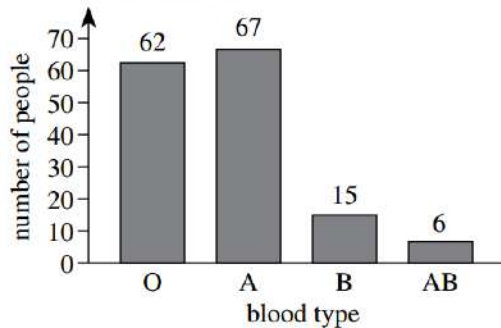

If 1 person from this study is randomly selected, what is the probability that this person has either Type A or Type AB blood?

- A. $\frac{62}{150}$
- B. $\frac{66}{150}$
- C. $\frac{68}{150}$
- D. $\frac{73}{150}$
- E. $\frac{84}{150}$

2.

The monthly fees for single rooms at 5 colleges are \$370, \$310, \$380, \$340, and \$310, respectively. What is the mean of these monthly fees?

- F. \$310
- G. \$340
- H. \$342
- J. \$350
- K. \$380

3.

The table below shows the number of cars Jing sold each month last year. What is the median of the data in the table?

Month	Number of cars sold
January	25
February	15
March	22
April	19
May	16
June	13
July	19
August	25
September	26
October	27
November	28
December	29

- F. 13
- G. 16
- H. 19
- J. 20.5
- K. 23.5

4.

Last month, Lucie had total expenditures of \$900. The pie chart below breaks down these expenditures by category. The category in which Lucie's expenditures were greatest is what percent of her total expenditures, to the nearest 1% ?

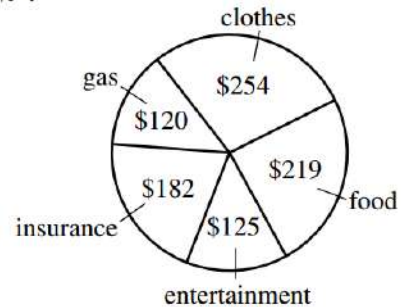

- A. 24%
- B. 28%
- C. 32%
- D. 34%
- E. 39%

5.

To make a 750-piece jigsaw puzzle more challenging, a puzzle company includes 5 extra pieces in the box along with the 750 pieces, and those 5 extra pieces do not fit anywhere in the puzzle. If you buy such a puzzle box, break the seal on the box, and immediately select 1 piece at random, what is the probability that it will be 1 of the extra pieces?

- A. $\frac{1}{5}$
- B. $\frac{1}{755}$
- C. $\frac{1}{750}$
- D. $\frac{5}{755}$
- E. $\frac{5}{750}$

6.

What is the median of the following 7 scores?

42, 67, 33, 79, 33, 89, 21

- A. 42
- B. 52
- C. 54.5
- D. 56
- E. 79

7.

Only tenth-, eleventh-, and twelfth-grade students attend Washington High School. The ratio of tenth graders to the school's total student population is 86:255, and the ratio of eleventh graders to the school's total student population is 18:51. If 1 student is chosen at random from the entire school, which grade is that student most likely to be in?

- A. Tenth
- B. Eleventh
- C. Twelfth
- D. All grades are equally likely.
- E. Cannot be determined from the given information

8.

Kelly asked 120 students questions about skiing. The results of the poll are shown in the table below.

Question	Yes	No
1. Have you skied either cross-country or downhill?	65	55
2. If you answered Yes to Question 1, did you ski downhill?	28	37
3. If you answered Yes to Question 1, did you ski cross-country?	45	20

After completing the poll, Kelly wondered how many of the students polled had skied both cross-country *and* downhill. How many of the students polled indicated that they had skied both cross-country and downhill?

- A. 73
- B. 65
- C. 47
- D. 18
- E. 8

9.

There are 280 runners registered for a race, and the runners are divided into 4 age categories, as shown in the table below.

Age category:	under 16	16–25	26–35	over 35
Number of runners:	40	76	112	52

The prize committee has 60 prizes to award and wants the prizes to be awarded in proportion to the number of runners registered in each category. How many prizes should be designated for the 26–35 age category?

- F. 15
- G. 17
- H. 24
- J. 36
- K. 40

10.

A poll of 200 registered voters was taken before the election for mayor of Springdale. All 200 voters indicated which 1 of the 4 candidates they would vote for. The results of the poll are given in the table below.

Candidate	Number of voters
Blackcloud	50
Lue	80
Gomez	40
Whitney	30

If the poll is indicative of how the 10,000 registered voters of Springdale will actually vote in the election, which of the following is the best estimate of the number of votes Lue will receive in the election?

- F. 1,500
- G. 2,500
- H. 4,000
- J. 5,000
- K. 8,000

Hard Questions Examples

1.

Minh cuts a board in the shape of a regular hexagon and pounds in a nail at an equal distance from each vertex, as shown in the figure below. How many rubber bands will she need in order to stretch a different rubber band across every possible pair of nails?

- A. 15
- B. 14
- C. 12
- D. 9
- E. 6

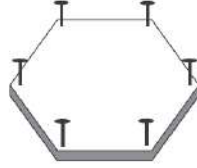

2.

For a project in Home Economics class, Kirk is making a tablecloth for a circular table 3 feet in diameter. The finished tablecloth needs to hang down 5 inches over the edge of the table all the way around. To finish the edge of the tablecloth, Kirk will fold under and sew down 1 inch of the material all around the edge. Kirk is going to use a single piece of rectangular fabric that is 60 inches wide. What is the shortest length of fabric, in inches, Kirk could use to make the tablecloth without putting any separate pieces of fabric together?

- F. 15
- G. 24
- H. 30
- J. 42
- K. 48

3.

The triangle, $\triangle XYZ$, that is shown below has side lengths of x , y , and z inches and is not a right triangle. Let X' be the image of X when the triangle is reflected across \overline{YZ} . Which of the following is an expression for the perimeter, in inches, of quadrilateral $X'YXZ$?

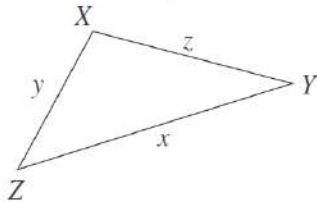

- F. $2(y + z) + x$
- G. $2(x + y + z)$
- H. $2(x + y)$
- J. $2(x + z)$
- K. $2(y + z)$

4.

In the right triangle below, $0 < b < a$. One of the angle measures in the triangle is $\tan^{-1}\left(\frac{a}{b}\right)$. What is $\cos\left[\tan^{-1}\left(\frac{a}{b}\right)\right]$?

- A. $\frac{a}{b}$
- B. $\frac{b}{a}$
- C. $\frac{a}{\sqrt{a^2 + b^2}}$
- D. $\frac{b}{\sqrt{a^2 + b^2}}$
- E. $\frac{\sqrt{a^2 + b^2}}{a}$

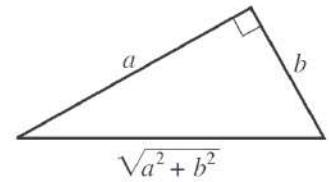

5.

The sum of an infinite geometric series with first term a and common ratio $r < 1$ is given by $\frac{a}{1-r}$. The sum of a given infinite geometric series is 200, and the common ratio is 0.15. What is the second term of this series?

- F. 25.5
- G. 30
- H. 169.85
- J. 170
- K. 199.85

Hard Questions Practice

1.

The graph of the equation $h = -at^2 + bt + c$, which describes how the height, h , of a hit baseball changes over time, t , is shown below.

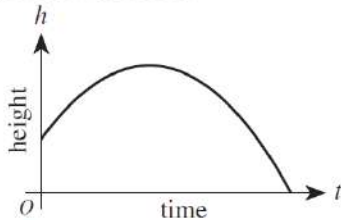

If you alter only this equation's c term, which gives the height at time $t = 0$, the alteration has an effect on which of the following?

- I. The h -intercept
- II. The maximum value of h
- III. The t -intercept

- F. I only
- G. II only
- H. III only
- J. I and III only
- K. I, II, and III

2.

The square below is divided into 3 rows of equal area. In the top row, the region labeled A has the same area as the region labeled B. In the middle row, the 3 regions have equal areas. In the bottom row, the 4 regions have equal areas. What fraction of the square's area is in a region labeled A?

- F. $\frac{1}{9}$
- G. $\frac{3}{9}$
- H. $\frac{6}{9}$
- J. $\frac{13}{12}$
- K. $\frac{13}{36}$

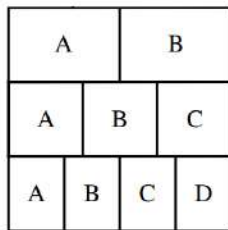

3.

As part of a probability experiment, Elliott is to answer 4 multiple-choice questions. For each question, there are 3 possible answers, only 1 of which is correct. If Elliott randomly and independently answers each question, what is the probability that he will answer the 4 questions correctly?

- A. $\frac{27}{81}$
- B. $\frac{12}{81}$
- C. $\frac{4}{81}$
- D. $\frac{3}{81}$
- E. $\frac{1}{81}$

4.

In the figure below, the area of the larger square is 50 square centimeters and the area of the smaller square is 18 square centimeters. What is x , in centimeters?

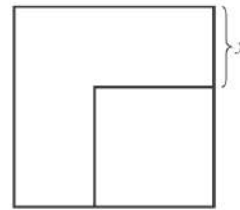

- F. 2
- G. $2\sqrt{2}$
- H. $4\sqrt{2}$
- J. 16
- K. 32

5.

An integer from 100 through 999, inclusive, is to be chosen at random. What is the probability that the number chosen will have 0 as at least 1 digit?

- A. $\frac{19}{900}$
- B. $\frac{81}{900}$
- C. $\frac{90}{900}$
- D. $\frac{171}{900}$
- E. $\frac{271}{1,000}$

6.

For every positive 2-digit number, x , with tens digit t and units digit u , let y be the 2-digit number formed by reversing the digits of x . Which of the following expressions is equivalent to $x - y$?

- F. $9(t - u)$
- G. $9(u - t)$
- H. $9t - u$
- J. $9u - t$
- K. 0

7.

In the figure below, $ABCD$ is a square. Points are chosen on each pair of adjacent sides of $ABCD$ to form 4 congruent right triangles, as shown below. Each of these has one leg that is twice as long as the other leg. What fraction of the area of square $ABCD$ is shaded?

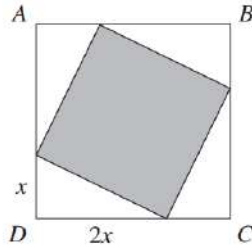

- A. $\frac{1}{9}$
- B. $\frac{2}{9}$
- C. $\frac{4}{9}$
- D. $\frac{5}{9}$
- E. $\frac{8}{9}$

8.

If $x:y = 5:2$ and $y:z = 3:2$, what is the ratio of $x:z$?

- A. 3:1
- B. 3:5
- C. 5:3
- D. 8:4
- E. 15:4

9.

In $\triangle ABC$, shown below, the measure of $\angle B$ is 41° , the measure of $\angle C$ is 34° , and \overline{AB} is 25 units long. Which of the following is an expression for the length, in units, of \overline{BC} ?

(Note: The law of sines states that, for any triangle, the ratios of the sines of the interior angles to the lengths of the sides opposite those angles are equal.)

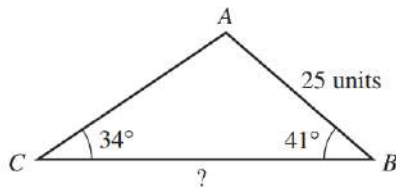

- A. $\frac{25 \sin 105^\circ}{\sin 41^\circ}$
- B. $\frac{25 \sin 105^\circ}{\sin 34^\circ}$
- C. $\frac{25 \sin 75^\circ}{\sin 41^\circ}$
- D. $\frac{25 \sin 41^\circ}{\sin 105^\circ}$
- E. $\frac{25 \sin 34^\circ}{\sin 75^\circ}$

10.

A flight instructor charges \$50 per lesson, plus an additional fee for the use of his plane. The charge for the use of the plane varies directly with the square root of the time the plane is used. If a lesson plus 16 minutes of plane usage costs \$90, what is the total amount charged for a lesson having 36 minutes of plane usage?

- A. \$185
- B. \$150
- C. \$135
- D. \$110
- E. \$ 60

Session 1 Answers

Pre-Algebra Teaching Problem Answers

- | | |
|-------|-------|
| 1. F | 2. J |
| 3. E | 4. E |
| 5. G | 6. D |
| 7. C | 8. K |
| 9. A | 10. G |
| 11. K | 12. H |
| 13. C | |

Pre-Algebra Practice Problem Answers

- | | |
|------|-------|
| 1. E | 2. F |
| 3. H | 4. D |
| 5. A | 6. K |
| 7. C | 8. C |
| 9. G | 10. K |

Science Interpretation of Data Sample Answers

- | | |
|-------|-------|
| 21. D | 22. F |
| 23. B | 24. J |
| 25. B | 26. H |

Science Interpretation of Data Practice Answers

- | | |
|-------|-------|
| 15. C | 16. F |
| 17. B | 18. H |
| 19. B | 20. J |
| 34. J | 35. A |
| 36. H | 37. B |
| 38. F | 39. D |
| 40. J | |

Algebra 1 Teaching Problem Answers

- | | |
|------|------|
| 1. B | 2. A |
| 3. K | 4. D |
| 5. B | 6. H |
| 7. C | 8. E |

- | | |
|-------|-------|
| 9. A | 10. J |
| 11. A | 12. D |
| 13. A | 14. D |
| 15. J | 16. K |
| 17. E | 18. E |
| 19. A | 20. J |

Session 2 Answers

Algebra 2 Teaching Problem Answers

- | | |
|-------|-------|
| 1. D | 2. C |
| 3. C | 4. C |
| 5. B | 6. A |
| 7. H | 8. A |
| 9. H | 10. B |
| 11. H | 12. J |
| 13. A | 14. E |
| 15. J | |

Algebra 1 and Algebra 2 Practice Problems Answers

- | | |
|-------|-------|
| 1. C | 2. H |
| 3. H | 4. K |
| 5. F | 6. A |
| 7. J | 8. E |
| 9. J | 10. F |
| 11. K | 12. A |
| 13. A | 14. E |
| 15. G | |

Science - Scientific Investigation Sample Answers

- | | |
|------|------|
| 1. C | 2. G |
| 3. D | 4. G |
| 5. C | 6. F |
| 7. A | |

Science - Scientific Investigation Practice Answers

- | | |
|-------|-------|
| 27. A | 28. J |
| 29. C | 30. F |
| 31. B | 32. G |
| 33. D | |
| 14. F | 15. C |
| 16. J | 17. A |
| 18. F | 19. B |

Session 3 Answers**Geometry Teaching Problem Answers**

- | | |
|-------|-------|
| 1. B | 2. G |
| 3. C | 4. C |
| 5. F | 6. H |
| 7. C | 8. D |
| 9. D | 10. H |
| 11. E | 12. F |
| 13. C | 14. B |
| 15. E | 16. J |
| 17. E | 18. G |
| 19. B | 20. E |
| 21. K | 22. G |

Geometry Practice Problems Answers

- | | |
|------|-------|
| 1. B | 2. F |
| 3. G | 4. G |
| 5. B | 6. C |
| 7. G | 8. F |
| 9. B | 10. F |

Science - Evaluation of Models Sample Answers

- | | |
|-------|-------|
| 8. F | 9. D |
| 10. J | 11. C |
| 12. F | 13. B |
| 14. F | |

Science - Evaluation of Models Practice Answers

- | | |
|-------|-------|
| 34. H | 35. D |
| 36. J | 37. A |
| 38. F | 39. B |
| 40. J | |
| 6. J | 7. B |
| 8. G | 9. D |
| 10. H | 11. A |
| 12. G | |

Session 4 Answers**Statistics Teaching Problem Answers**

- | | |
|------|-------|
| 1. E | 2. A |
| 3. B | 4. F |
| 5. H | 6. F |
| 7. H | 8. D |
| 9. B | 10. A |

Statistics Practice Problems Answers

- | | |
|------|-------|
| 1. D | 2. H |
| 3. K | 4. B |
| 5. D | 6. A |
| 7. B | 8. E |
| 9. H | 10. H |

Hard Question Example Answers

- | | |
|------|------|
| 1. A | 2. K |
| 3. K | 4. D |
| 5. F | |

Hard Problem Practice Answers

- | | |
|------|-------|
| 1. K | 2. K |
| 3. E | 4. G |
| 5. D | 6. F |
| 7. D | 8. E |
| 9. B | 10. D |