

8th grade Math Team Summer Packet

Before starting 8th grade math team you should be able to:

- ◆ Simplify integer expressions
- ◆ Solve multi-step equations and inequalities
- ◆ Apply the Pythagorean Theorem and know the common Pythagorean Triples
- ◆ Write square roots in simplest radical form
- ◆ Find the area of 2-D figures
- ◆ Find surface area and volume of 3-D geometric shapes
- ◆ Graph linear equations from slope-intercept form and standard form
- ◆ Write the equation of a line in slope-intercept form, given a graph
- ◆ Graph the a line, given the equation in slope-intercept form
- ◆ Solve a system of linear equations by graphing, substitution, and elimination
- ◆ Convert from fractions to decimals to percents
- ◆ Convert repeating decimals to fractions
- ◆ Convert from base 10 to other bases and vice versa
- ◆ Attempt to work all the problems on the tournament tests in this packet
- ◆ memorize factorials up to 10 (timed quiz 1st week)
- ◆ memorize all square roots up to 20 and cube roots up to 10 (timed quiz 1st week)
- ◆ memorize common fraction - decimal - percent equivalents (timed quiz 1st week)
- ◆ Chapters 1-3 Pre-Test (will be collected the first day- write final answers on test paper, but attach work that has been shown on separate paper. Failure to follow directions will result in a 0.)

Your assignment is to review all of the material in this packet over the summer and to complete all of the problems. These are concepts you should have learned in 7th grade math team class, so I will not be taking anytime in class to review these concepts. This entire packet will not be taken up for a grade, but you will be expected to know the material well that the worksheets cover. The final worksheet in the packet is a Pre-Test for Chapters 1-3 in the Algebra book. You will be turning that in the first day of school and I will use this to determine what concepts covered in those chapters that I will need to teach. The Pre-Test will be collected for a grade before you take the test, once you have a chance to correct any mistakes. You will then take the actual Chapters 1-3 Test that will count for a test grade.

All of the worksheets in this packet should be completed WITHOUT the aid of a calculator.

◆ Be sure to bring the completed Ch 1-3 Pre-Test to school the first day.

I look forward to meeting you in August.

Ms. Shurer

Math Team Grade 8 - Things to Know

Be prepared to take a quiz on this material the **First Week** of school

Write each as a percent, decimal, and fraction. *(Timed quiz)*

- $\frac{1}{2} = .5 = 50\%$ $\frac{1}{3} = .3\bar{3} = 33\frac{1}{3}\%$ $\frac{2}{3} = .6\bar{6} = 66\frac{2}{3}\%$ $\frac{1}{4} = .25 = 25\%$ $\frac{3}{4} = .75 = 75\%$
 $\frac{1}{5} = .2 = 20\%$ $\frac{2}{5} = .4 = 40\%$ $\frac{3}{5} = .6 = 60\%$ $\frac{4}{5} = .8 = 80\%$
 $\frac{1}{6} = .1\bar{6} = 16\frac{2}{3}\%$ $\frac{5}{6} = .8\bar{3} = 83\frac{1}{3}\%$
 $\frac{1}{8} = .125 = 12\frac{1}{2}\%$ $\frac{3}{8} = .375 = 37\frac{1}{2}\%$ $\frac{5}{8} = .625 = 62\frac{1}{2}\%$ $\frac{7}{8} = .875 = 87\frac{1}{2}\%$
 $\frac{1}{9} = .1\bar{1} = 11\frac{1}{9}\%$ $\frac{2}{9} = .2\bar{2} = 22\frac{2}{9}\%$ $\frac{4}{9} = .4\bar{4} = 44\frac{4}{9}\%$ etc.
 $\frac{1}{12} = .08\bar{3} = 8\frac{1}{3}\%$ $\frac{5}{12} = .41\bar{6} = 41\frac{2}{3}\%$ $\frac{7}{12} = .58\bar{3} = 58\frac{1}{3}\%$ $\frac{11}{12} = .91\bar{6} = 91\frac{2}{3}\%$

Pythagorean Theorem : $a^2 + b^2 = c^2$

Triples:

- 3, 4, 5 9, 40, 41
 5, 12, 13 11, 60, 61
 7, 24, 25 20, 21, 29
 8, 15, 17

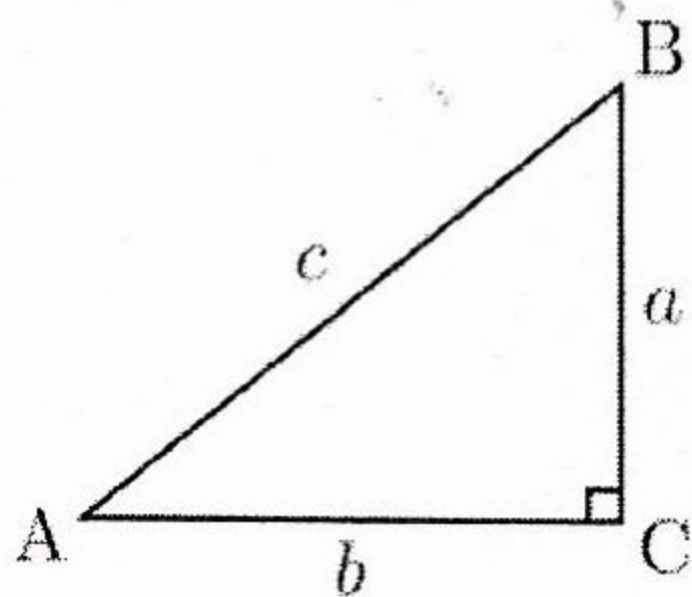

Polygons	# of sides	# of angles	# of vertices	# of diagonals
triangle	3	3	3	0
quadrilateral	4	4	4	2
pentagon	5	5	5	5
hexagon	6	6	6	9
heptagon	7	7	7	14
octagon	8	8	8	20
nonagon	9	9	9	27
decagon	10	10	10	35
dodecagon	12	12	12	54
icosagon	20	20	20	170

Exponents *(Timed Quiz)*

- $0^2 = 0$ $1^2 = 1$ $2^2 = 4$ $3^2 = 9$ $4^2 = 16$ $5^2 = 25$ $6^2 = 36$
 $7^2 = 49$ $8^2 = 64$ $9^2 = 81$ $10^2 = 100$ $11^2 = 121$ $12^2 = 144$ $13^2 = 169$
 $14^2 = 196$ $15^2 = 225$ $16^2 = 256$ $17^2 = 289$ $18^2 = 324$ $19^2 = 361$ $20^2 = 400$
 $21^2 = 441$ $25^2 = 625$ $30^2 = 900$ $35^2 = 1225$ $40^2 = 1600$ $45^2 = 2025$ $55^2 = 3025$
 $65^2 = 4225$ $1^3 = 1$ $2^3 = 8$ $3^3 = 27$ $4^3 = 64$ $5^3 = 125$ $6^3 = 216$
 $7^3 = 343$ $8^3 = 512$ $9^3 = 729$ $10^3 = 1000$ $11^3 = 1331$ $12^3 = 1728$ $20^3 = 8000$

Square Roots and Cube Roots

$\sqrt{4} = 2$	$\sqrt{9} = 3$	$\sqrt{16} = 4$	$\sqrt{25} = 5$	$\sqrt{36} = 6$	$\sqrt{49} = 7$	$\sqrt{64} = 8$	$\sqrt{81} = 9$
$9 \sqrt{100} = 10$	$\sqrt{121} = 11$	$\sqrt{144} = 12$	$\sqrt{169} = 13$	$\sqrt{196} = 14$	$\sqrt{225} = 15$	$\sqrt{256} = 16$	
$\sqrt{289} = 17$	$\sqrt{324} = 18$	$\sqrt{361} = 19$	$\sqrt{400} = 20$	$\sqrt[3]{1} = 1$	$\sqrt[3]{8} = 2$	$\sqrt[3]{27} = 3$	$\sqrt[3]{64} = 4$
$\sqrt[3]{125} = 5$	$\sqrt[3]{216} = 6$	$\sqrt[3]{343} = 7$	$\sqrt[3]{512} = 8$	$\sqrt[3]{729} = 9$	$\sqrt[3]{1000} = 10$		

Formulas

Circle: circumference = $2\pi r$ or πd area = πr^2 $\pi = 3.14$ or $22/7$

Triangle: area = $\frac{1}{2}bh$ perimeter $a + b + c$

Square: area = s^2 perimeter $4s$

Rectangle: area = lw perimeter = $2l + 2w$

Trapezoid: area = $\frac{1}{2}h(b_1 + b_2)$

Parallelogram: area = bh

Cube  Volume = s^3
surface area = $6s^2$

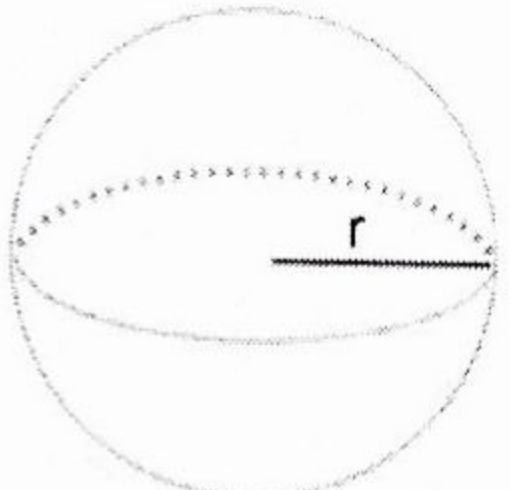
Sphere  Volume = $\frac{4}{3}\pi r^3$
Surface Area = $4\pi r^2$

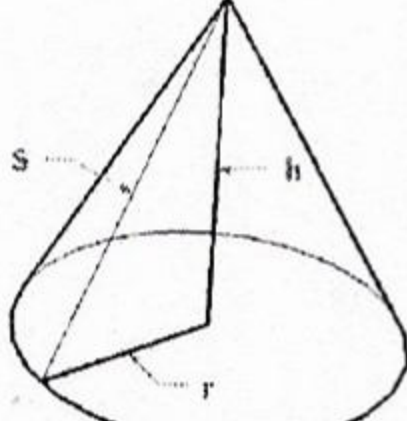
Cone  Volume = $\frac{1}{3}\pi r^2 h$
surface area = $\pi r s + \pi r^2$

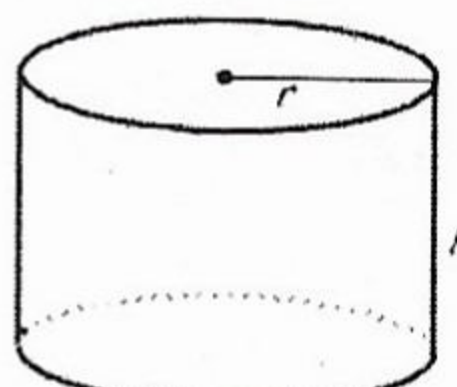
Cylinder  Volume = $\pi r^2 h$
Surface Area = $2\pi r^2 + 2\pi r h$

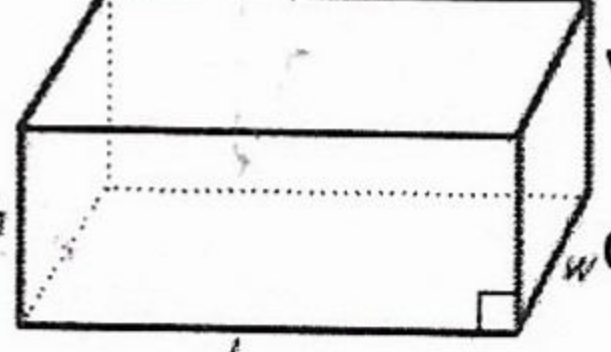
Rectangular solid  volume = lwh
surface area = $2lw + 2wh + 2lh$

Interest = prt (Interest = principal x rate x time)

Distance = rt (distance = rate x time)

Percent of change = $\text{change}/\text{original}$

Prime Numbers between 1 and 150: 2, 3, 5, 7, 11, 13, 17, 19, 23, 29, 31, 37, 41, 43, 47, 53, 59, 61, 67, 71, 73, 79, 83, 89, 97, 101, 103, 107, 109, 113, 127, 131, 137, 139, 149

Factorials (timed quiz)

$0! = 1$	$1! = 1$	$2! = 2$	$3! = 6$	$4! = 24$	$5! = 120$
$6! = 720$	$7! = 5040$	$8! = 40320$	$9! = 362,880$	$10! = 3,628,800$	$n! = 1 \times 2 \times 3 \times \dots \times n$

Volume and Surface Area Practice

In Exercises 1–14, use 3.14 for π .

- Find the volume of a cylinder with a radius of 2 meters and a height of 4 meters.
- Find the volume of a cylinder with a base area of 625π in.² and a height of 25 inches.
- Find the volume of a cylinder with a diameter of 16 inches and a height of 4 inches.
- Find the volume of a cylinder with a circumference of 25π and a height of 7.5 cm. (Hint: Use the circumference to find the radius.)

In Exercises 5–8, find the volume of the cylinder.

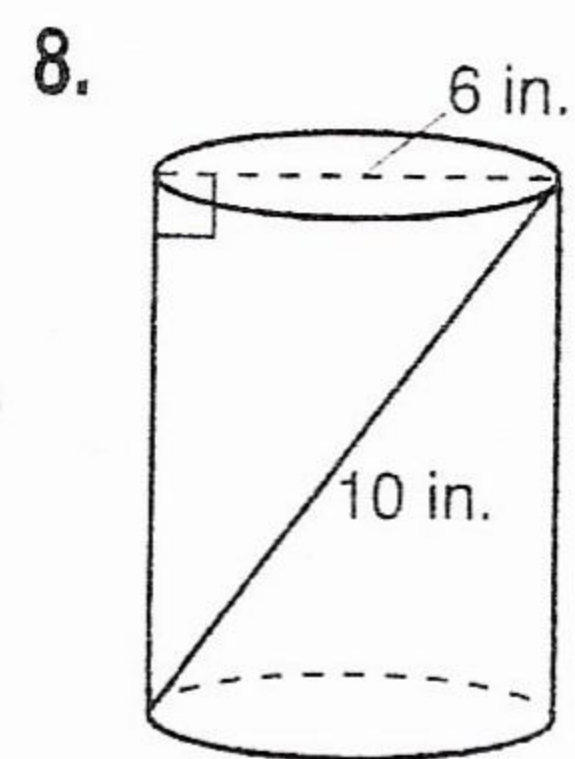
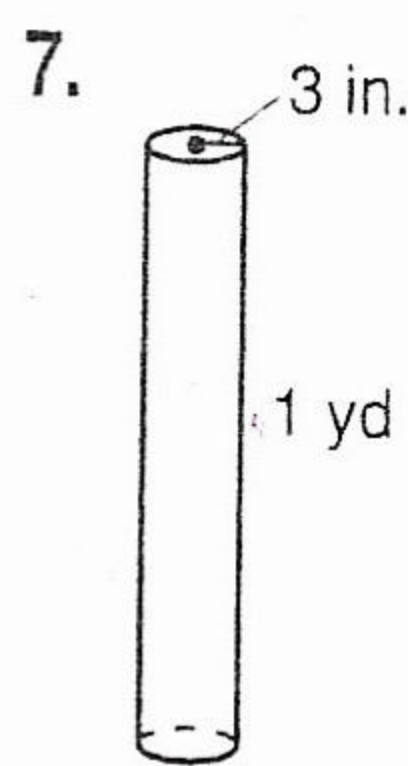
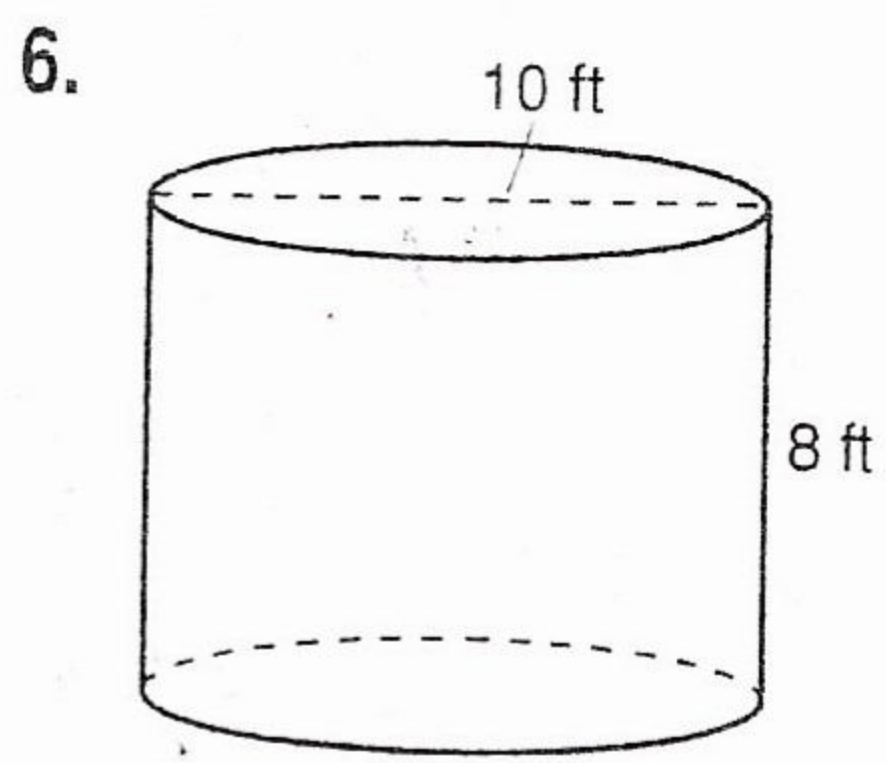
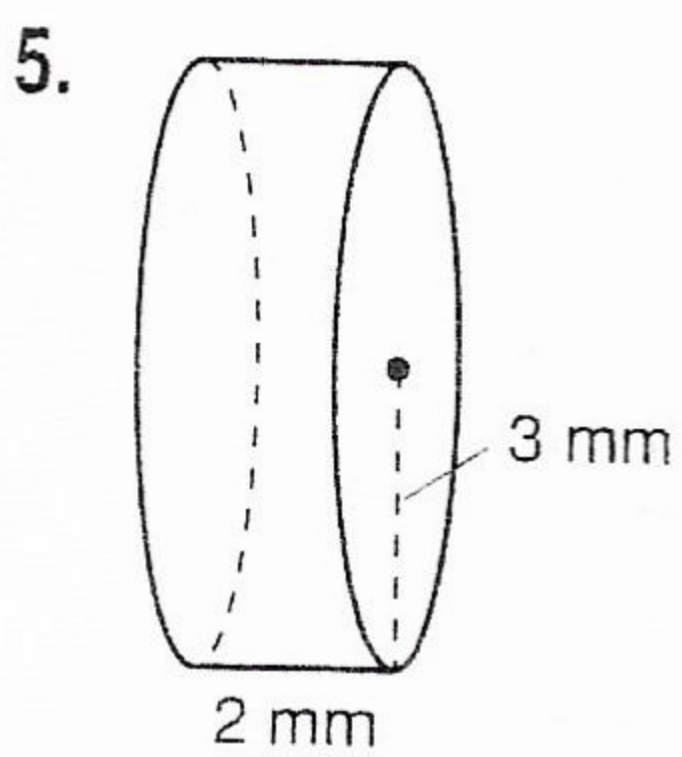

In Exercises 1–4, find the volume of the solid. Use 3.14 for π . Round your results to one decimal place.

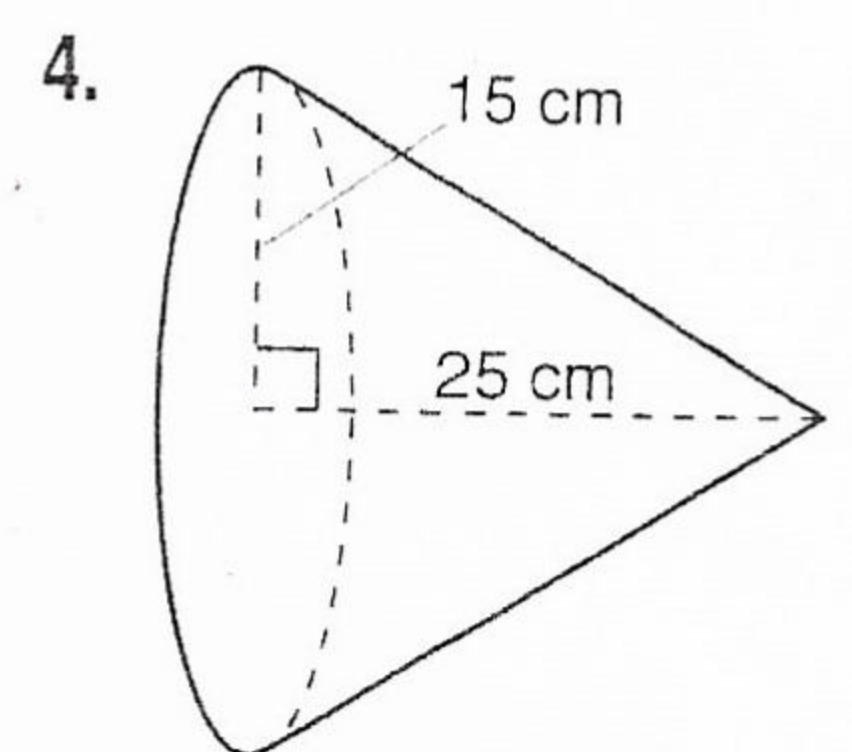
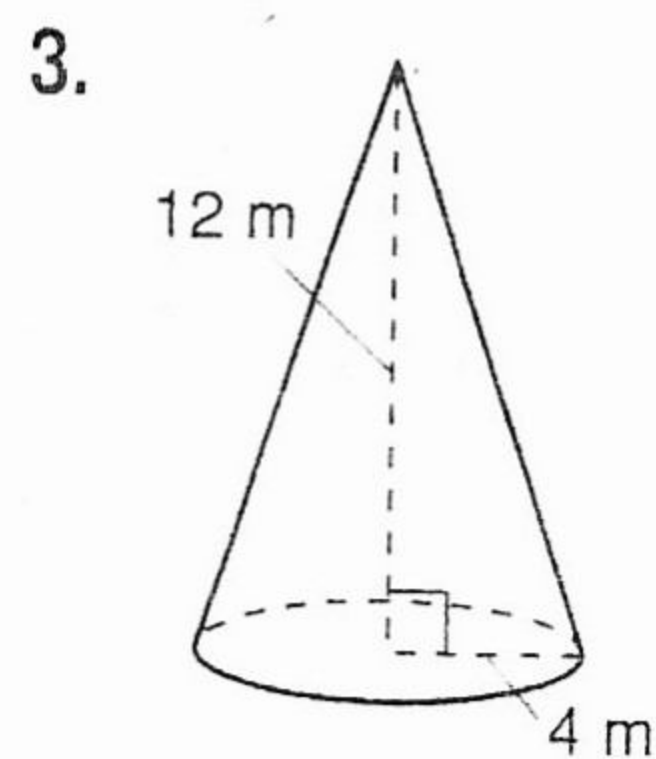
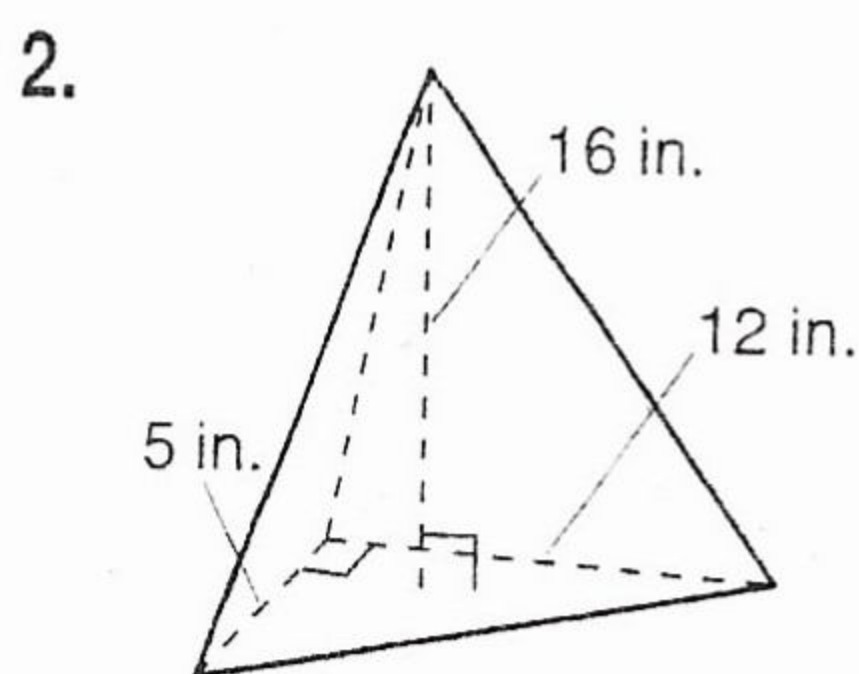
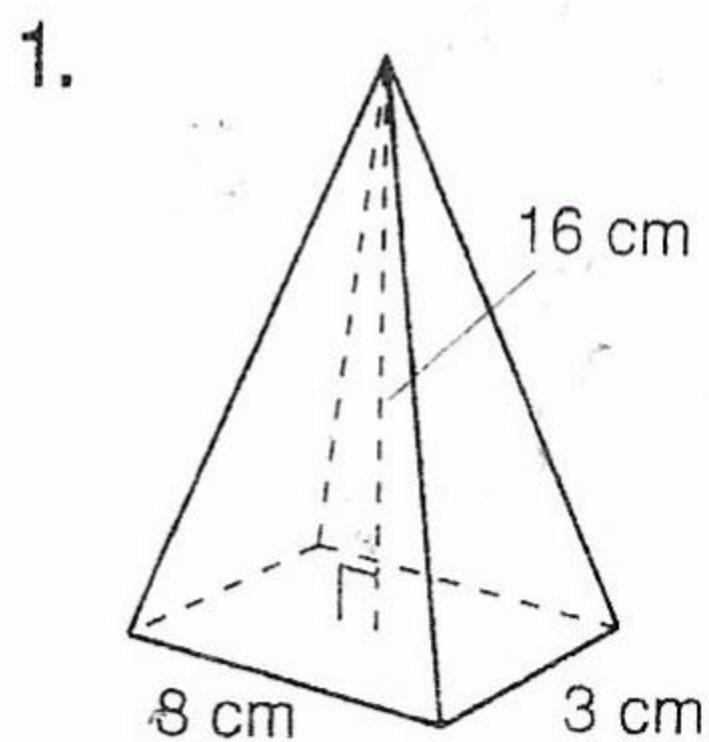

In Exercises 7–9, find the volume of the solid. Use 3.14 for π . Round your result to one decimal place.

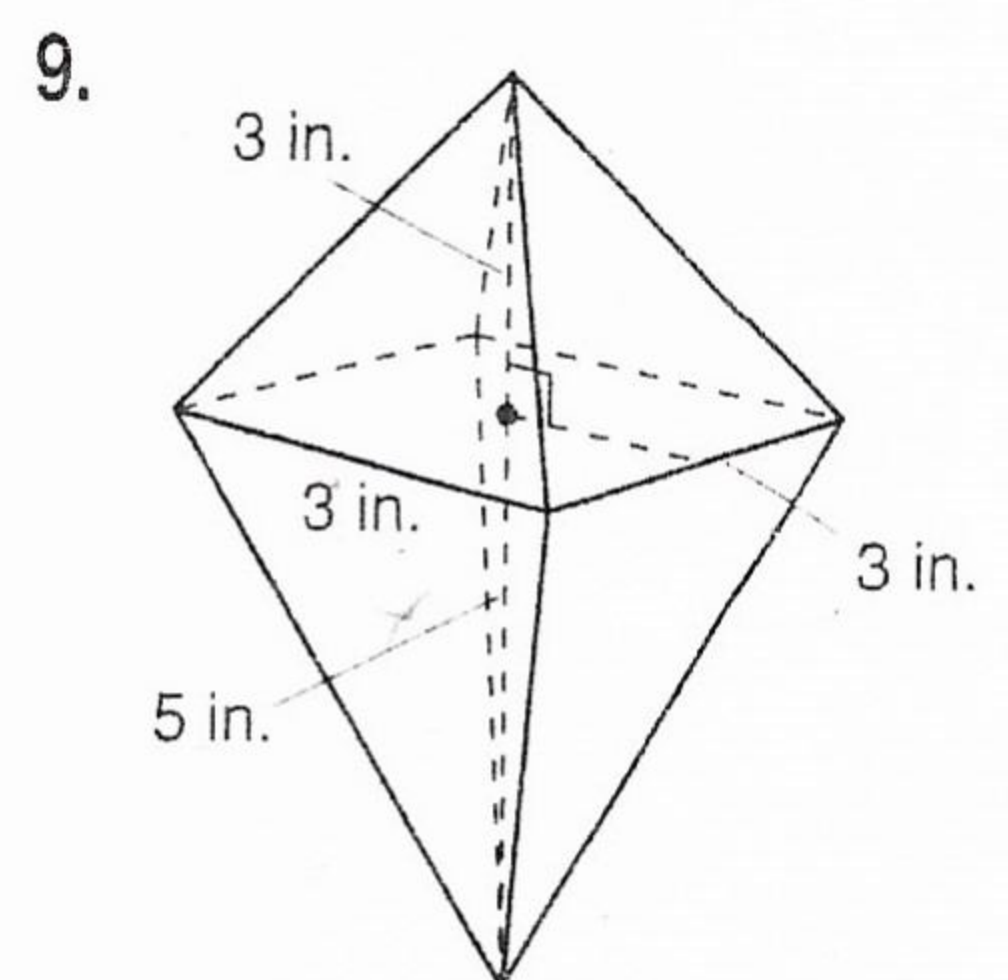
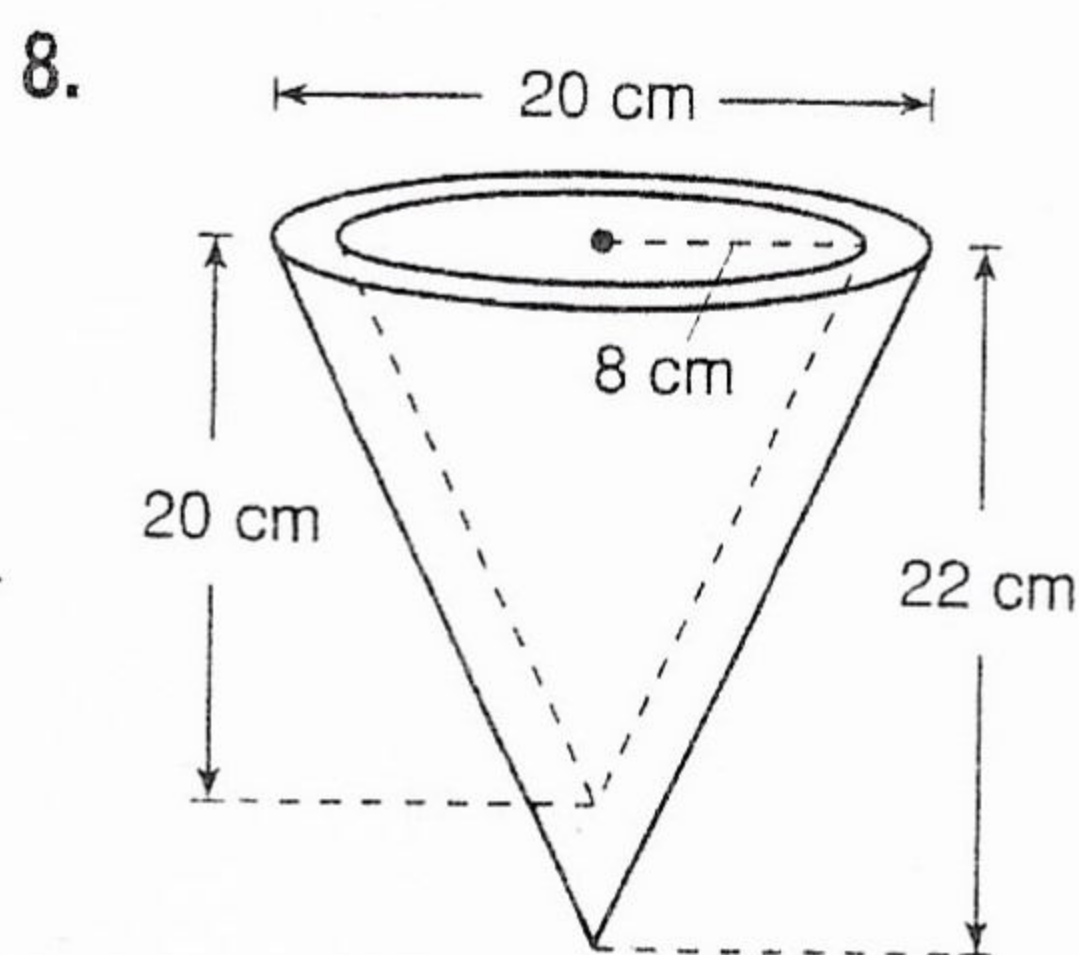
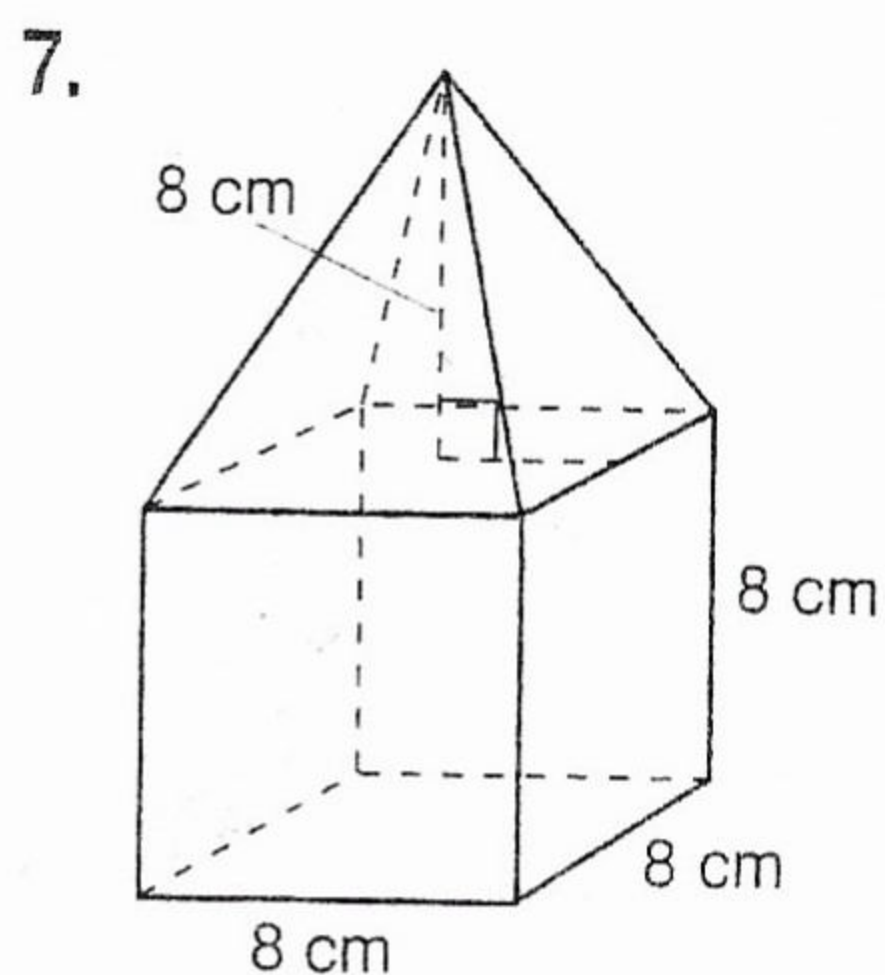

In Exercises 1–6, find the surface area of the right prism or right cylinder. Use 3.14 for π . Round your results to one decimal place.

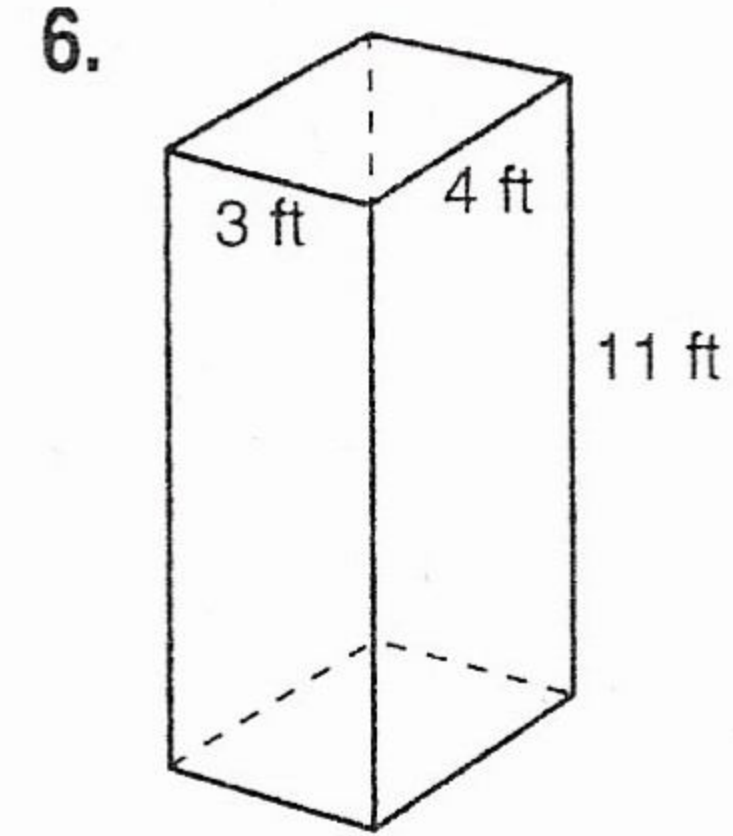
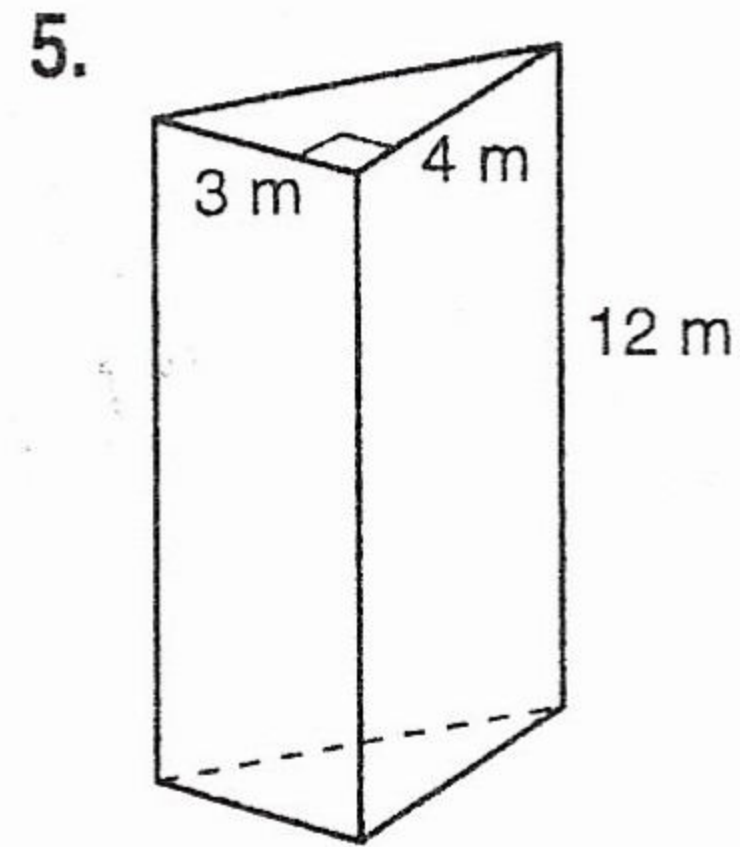
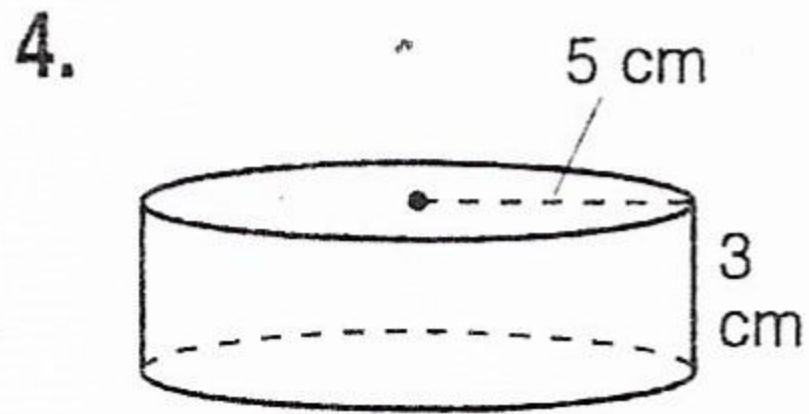
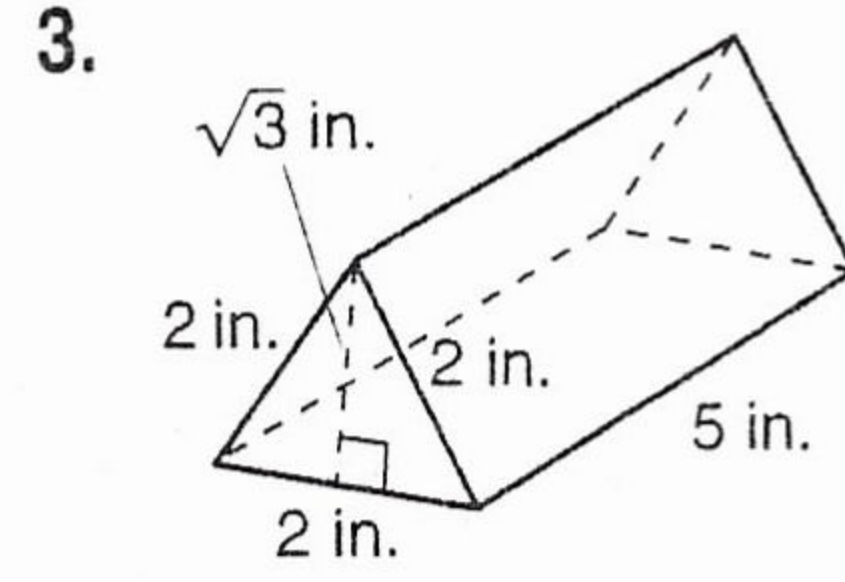
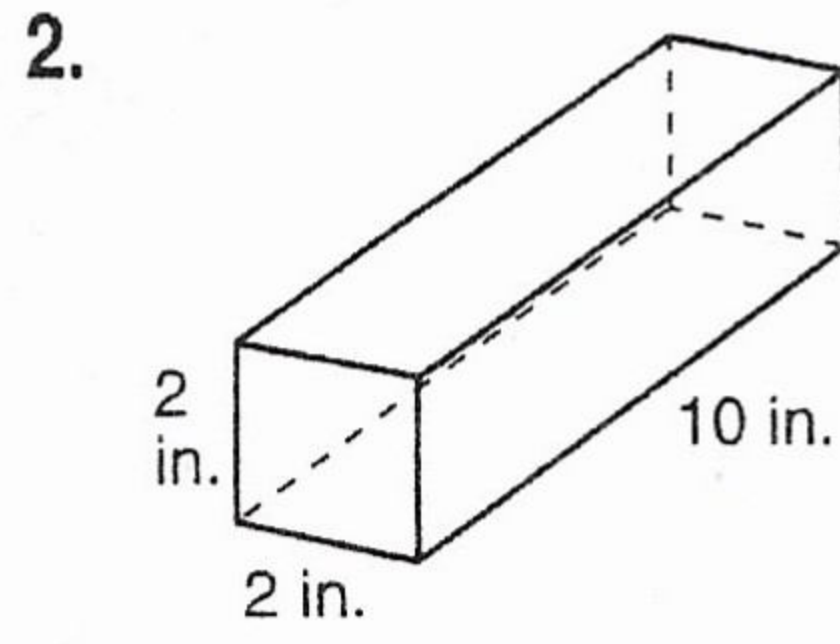
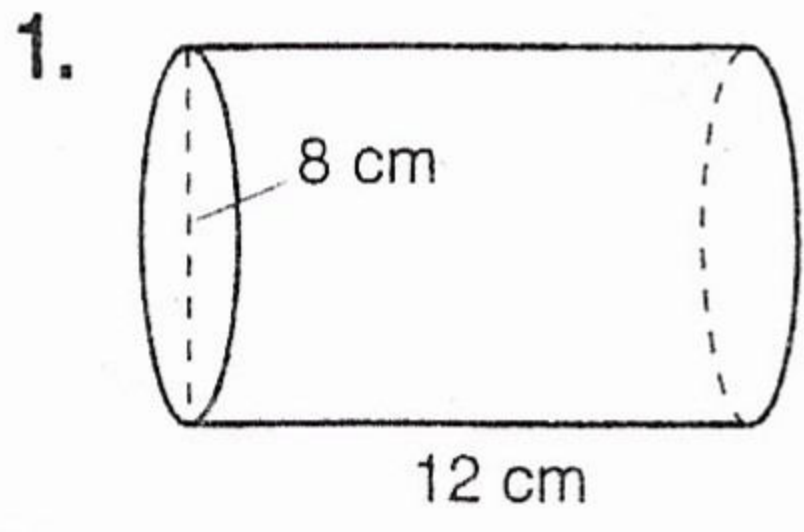

Repeating Decimals Worksheet

Directions: Convert each decimal to a fraction.

1. $0.\overline{6}$	2. $2.\overline{6}$	3. $0.\overline{54}$	4. $-6.\overline{2}$
5. $0.\overline{45}$	6. $1.\overline{6}$	7. $0.\overline{46}$	8. $-7.\overline{6}$
9. $0.\overline{26}$	10. $0.\overline{583}$	11. $\overline{.235714}$	12. $0.\overline{90}$
13. $0.\overline{2}$	14. $0.\overline{7}$	15. $1.\overline{16}$	16. $\overline{.8}$
17. $0.\overline{53}$	18. $0.\overline{61}$	19. $0.\overline{4}$	20. $0.\overline{3}$
21. $7.\overline{83}$	22. $0.\overline{083}$	23. $-2.\overline{06}$	24. $0.\overline{72}$

Example:
$$\begin{array}{r} 10n = 1.\overline{6} \\ - \quad n = .\overline{6} \\ \hline 9n = 1.5 \end{array}$$
 one digit repeats (x both sides by 10)

subtract

$$\frac{9n}{9} = \frac{1.5}{9}$$

$$n = \frac{1.5}{9} = \frac{15 \div 15}{90 \div 15} = \frac{1}{6}$$

so $.\overline{6} = \frac{1}{6}$

This is why the method Mrs. Colley showed you works

Note: if 2 digits repeat, x by 100; 3- x by 1000, etc.
This step removes the repeating part of the decimal

Changing Bases Worksheet

Change each base 10 numeral to base 2.

1. 54

2. 384

3. 10

4. 516

5. 40

Change each base 10 numeral to base 4.

6. 38

7. 2049

8. 12

9. 564

10. 388

Change each base 10 numeral to base 5.

11. 488

12. 15

13. 5017

14. 283

15. 5000

Change each base 10 numeral to base 8.

16. 247

17. 317

18. 56

19. 27

20. 687

Example change 31 to base 2

Mrs. Colley may have shown you
a different method to do these.
I don't care what method you use.

$$\begin{array}{r}
 \text{Powers} \\ \text{of 2} \\
 16 \overline{) 31} \quad | \\
 \underline{8} \quad \quad | \\
 4 \overline{) 7} \quad | \\
 \underline{2} \quad \quad | \\
 2 \overline{) 3} \quad | \\
 \underline{1} \quad \quad | \\
 31 = 11111_2
 \end{array}$$

The numbers
in the L
are the remainder
for each division.

How Did the Light Dress Up For the Costume Party?

For each exercise, draw the line indicated and write its equation. Find your answer in the answer column and cross out the letter next to it. When you finish, the answer to the title question will remain.

Answers 1-6
$y = 2x - 6$
$y = \frac{2}{3}x - 4$
$y = -\frac{4}{3}x - 4$
$y = \frac{5}{6}x$
$y = 2x + 3$
$y = -\frac{1}{2}x + 3$
$y = -3x + 5$
$y = -\frac{4}{3}x - 1$
$y = \frac{2}{3}x - 1$
$y = -3x - 6$
$y = -\frac{1}{2}x + 5$

Answers 7-12
$y = -x - 5$
$y = -4$
$y = \frac{5}{2}x + 1$
$y = -4x + 2$
$x = 3$
$y = -4x - 5$
$y = -3$
$y = \frac{5}{2}x + 4$
$x = 4$
$y = -x + 2$
$y = \frac{1}{6}x + 4$

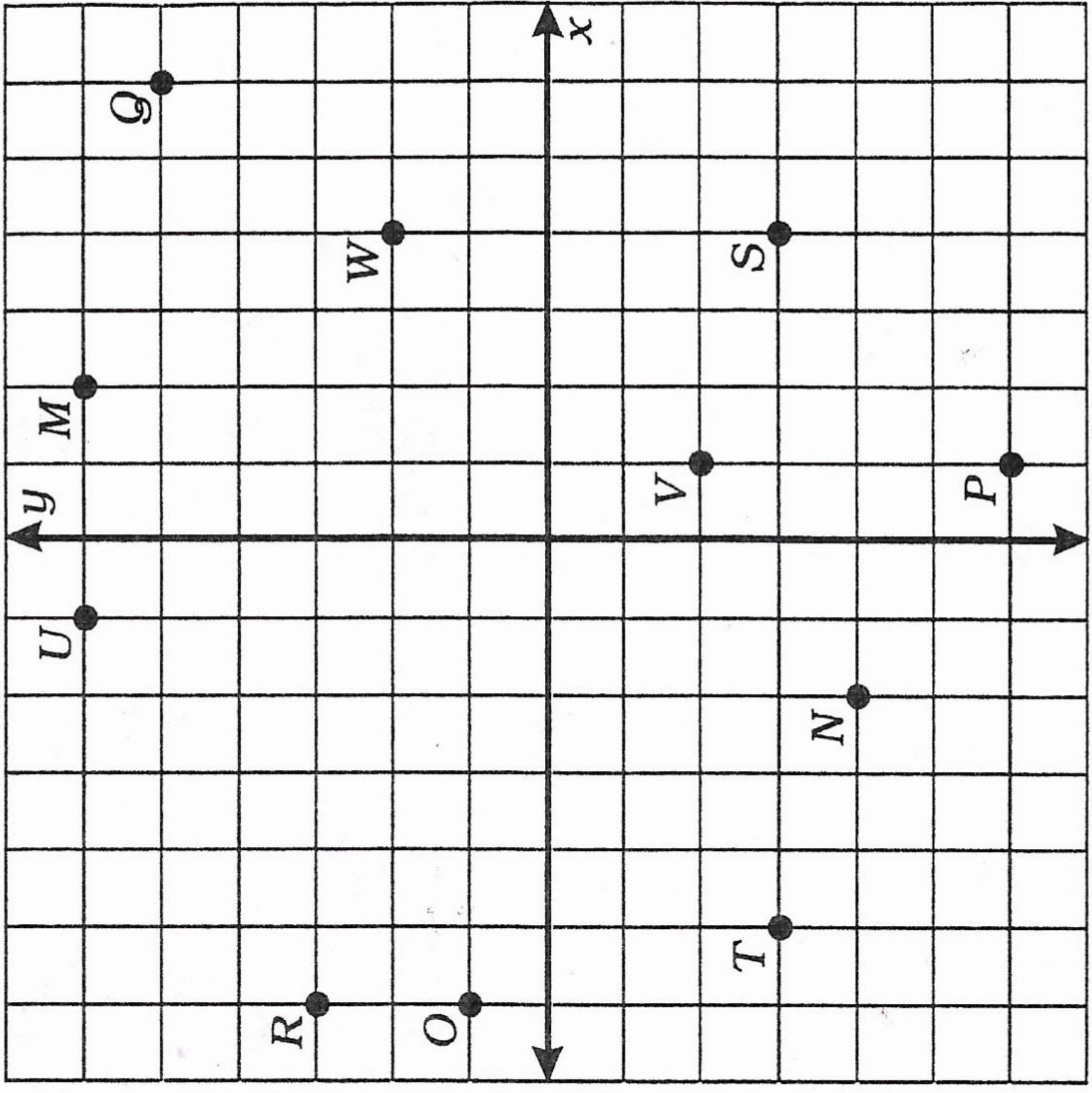
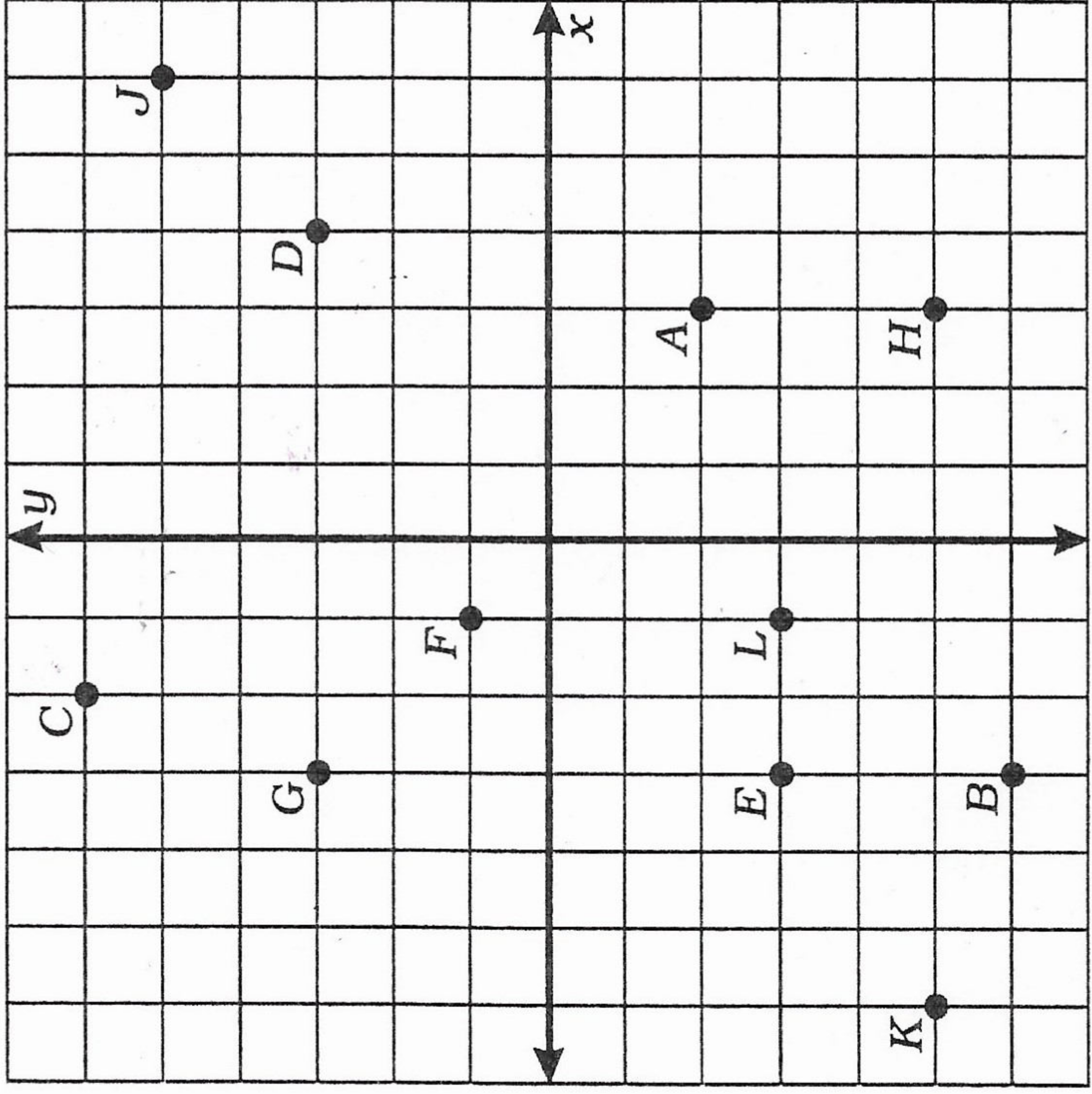

- Equation of \overleftrightarrow{AB} _____
- Equation of \overleftrightarrow{CD} _____
- Equation of \overleftrightarrow{EF} _____
- Equation of \overleftrightarrow{GH} _____
- Equation of \overleftrightarrow{JK} _____
- Equation of \overleftrightarrow{KL} _____

- Equation of \overleftrightarrow{MN} _____
- Equation of \overleftrightarrow{OP} _____
- Equation of \overleftrightarrow{QR} _____
- Equation of \overleftrightarrow{ST} _____
- Equation of \overleftrightarrow{UV} _____
- Equation of \overleftrightarrow{SW} _____

work for all ($m =$
 $b =$



What Did the Teacher Do With Ogar's Cheese Report?

Solve each system of equations by graphing. Cross out the letters above each correct answer. When you finish, the remaining letters will tell you the answer to the title question.

1. $y = \frac{3}{2}x - 1$
 $y = -x + 4$

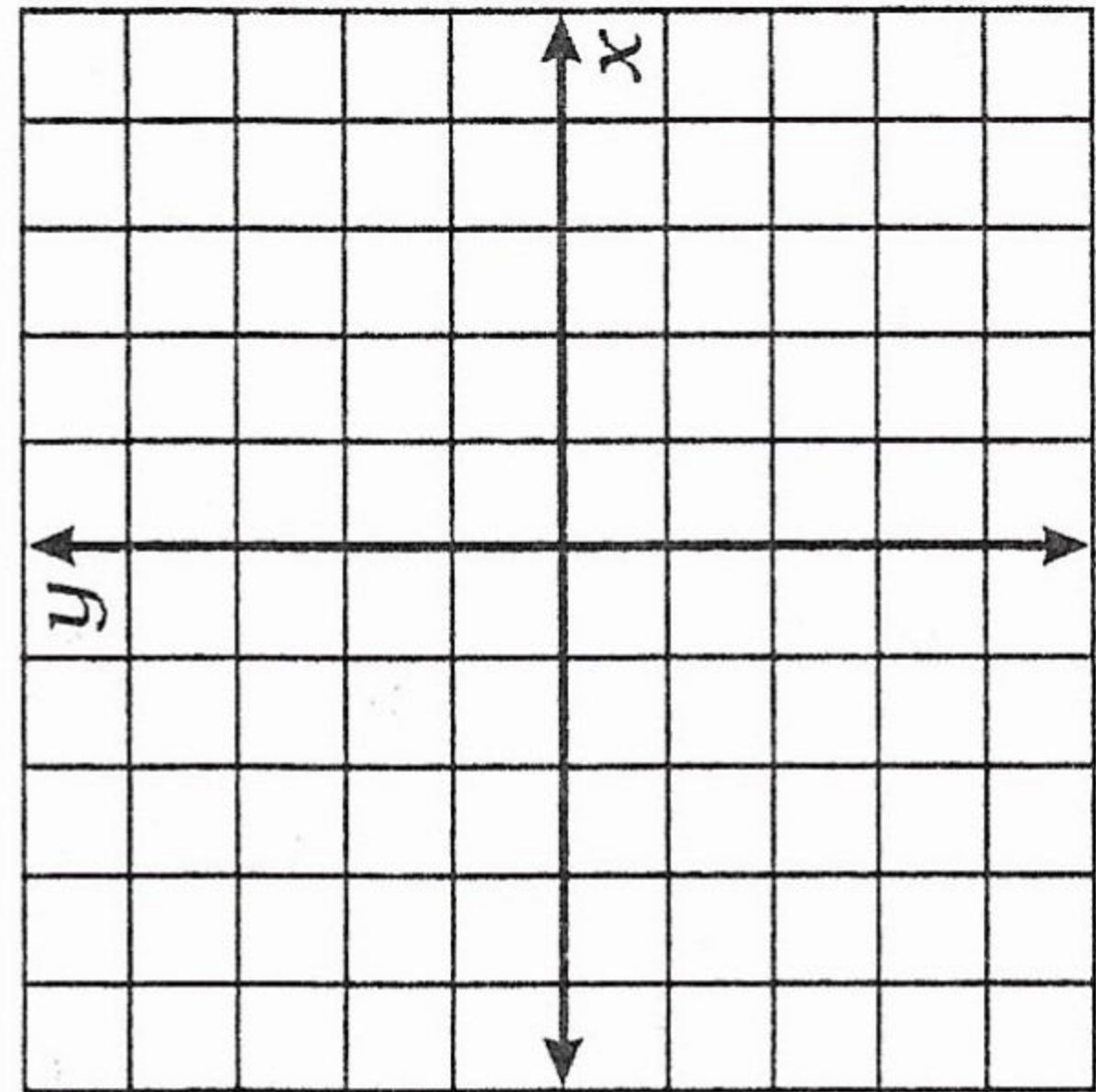

2. $y = \frac{1}{3}x + 2$
 $y = -\frac{4}{3}x - 3$

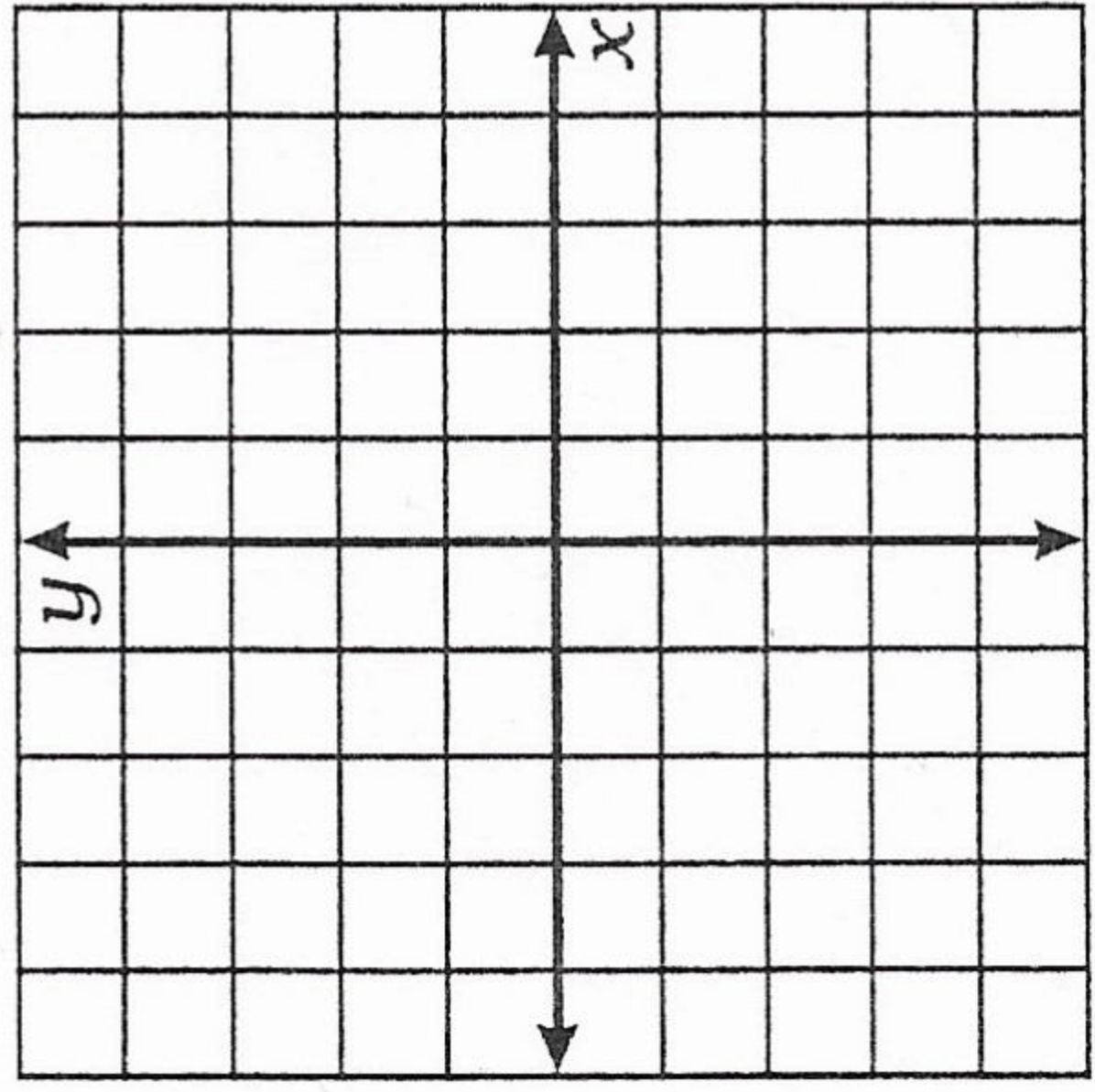

3. $y = 2x + 1$
 $-2x + 3y = -9$

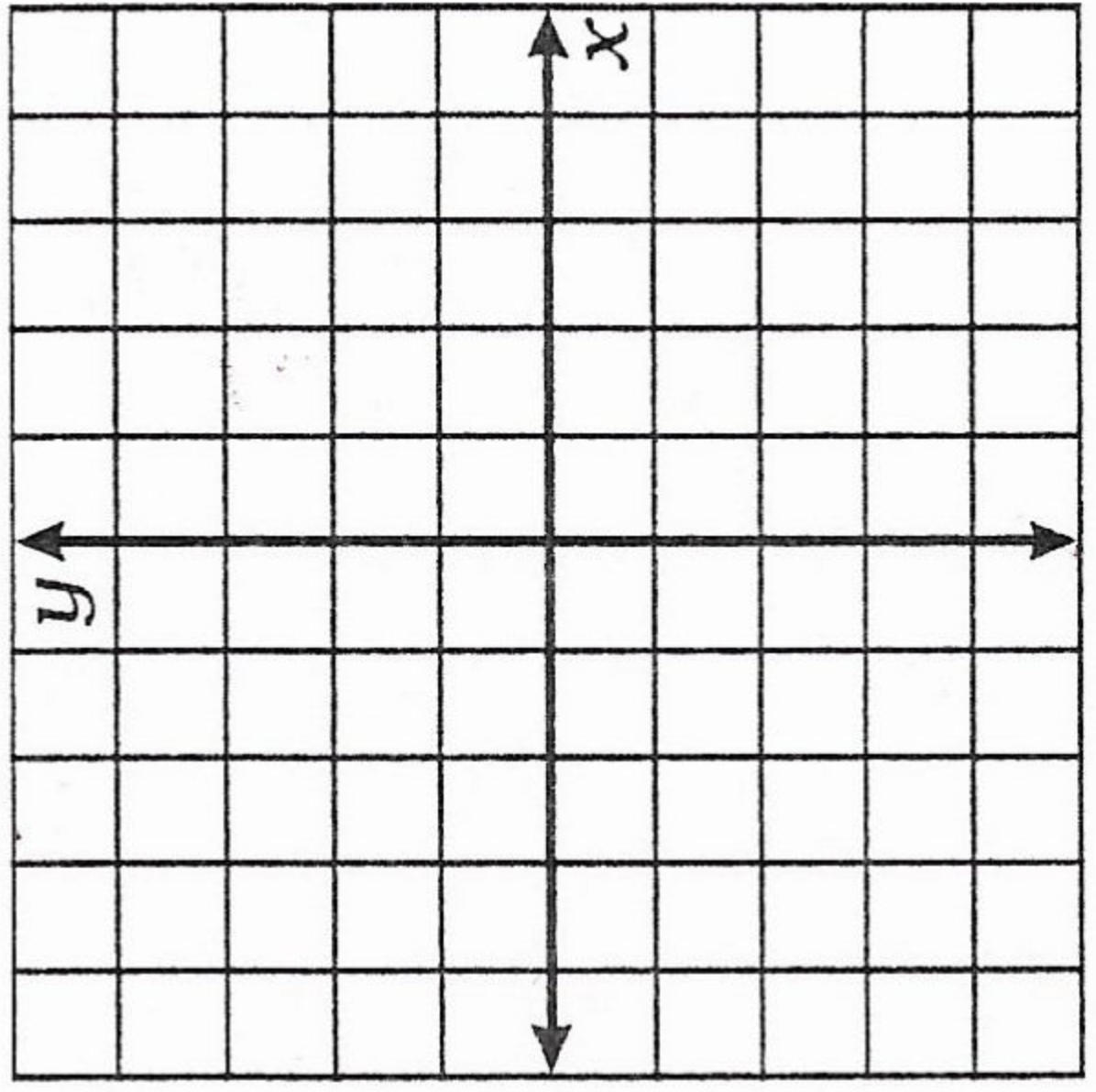

4. $3x + y = 0$
 $x - y = 4$

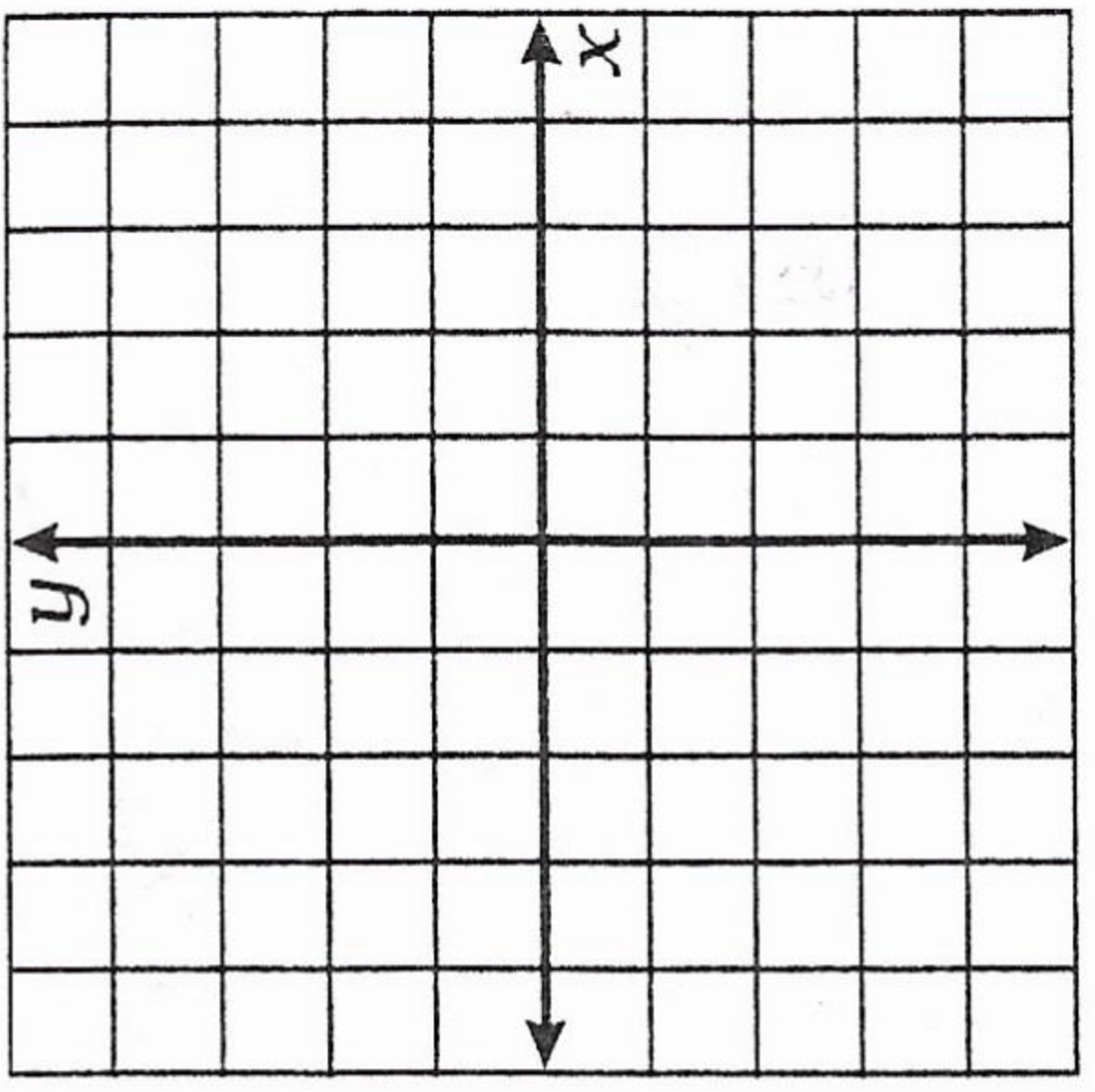

5. $-3x + 4y = 8$
 $x + 2y + 6 = 0$

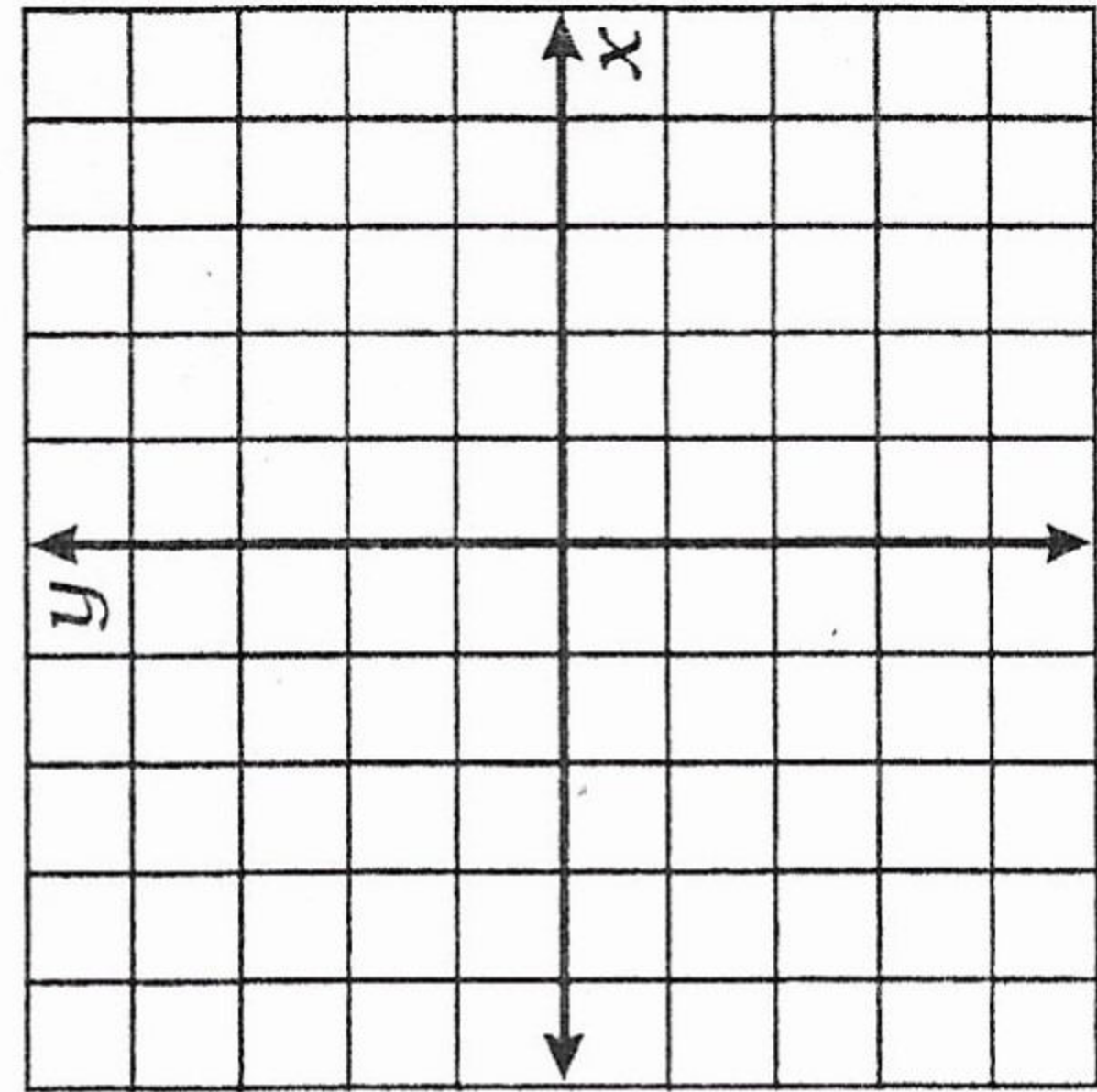

6. $7x - 5y = 20$
 $-8x - 3y = 12$

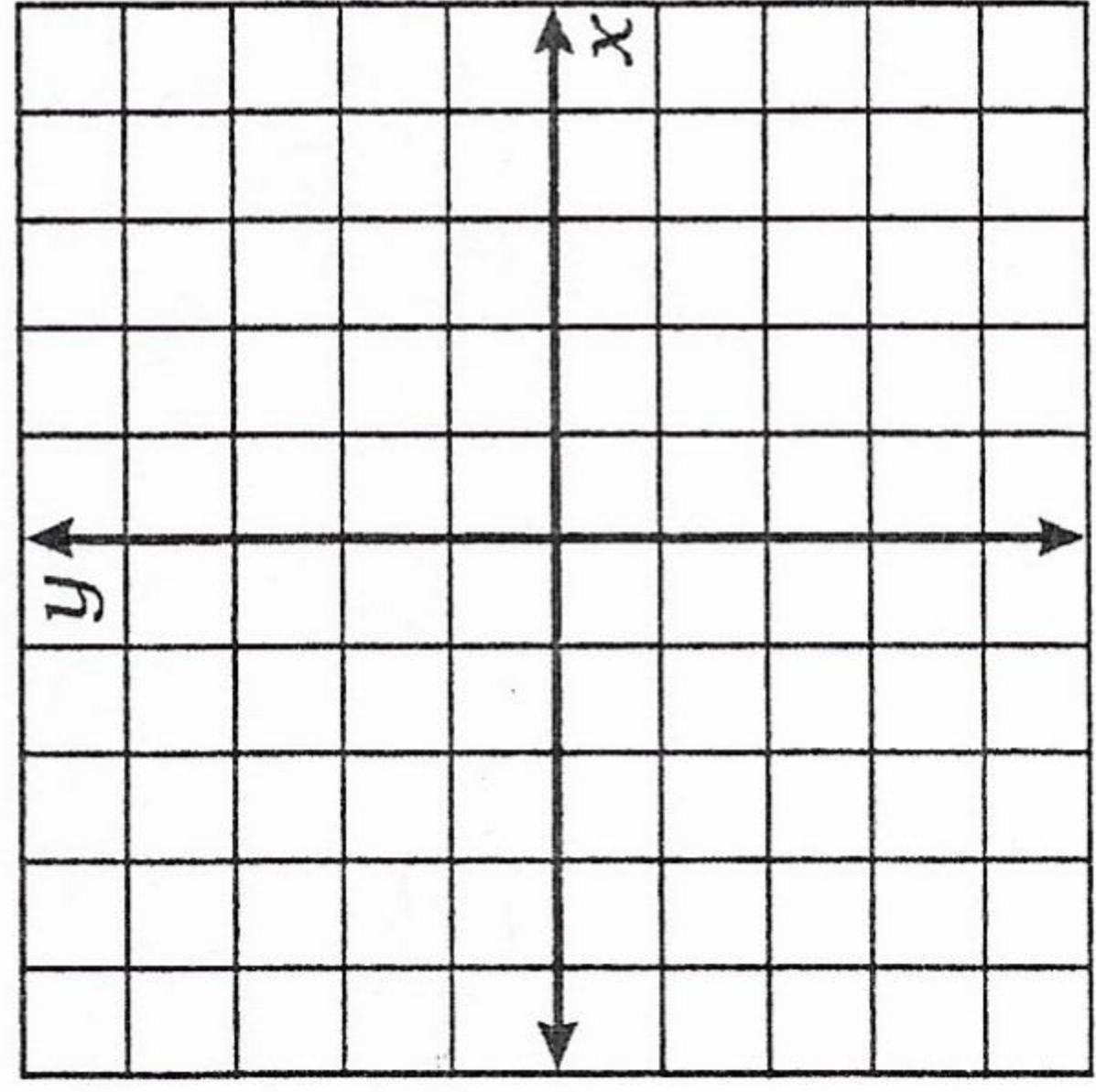

7. $-x - 4y = 12$
 $20x + 80y = 0$

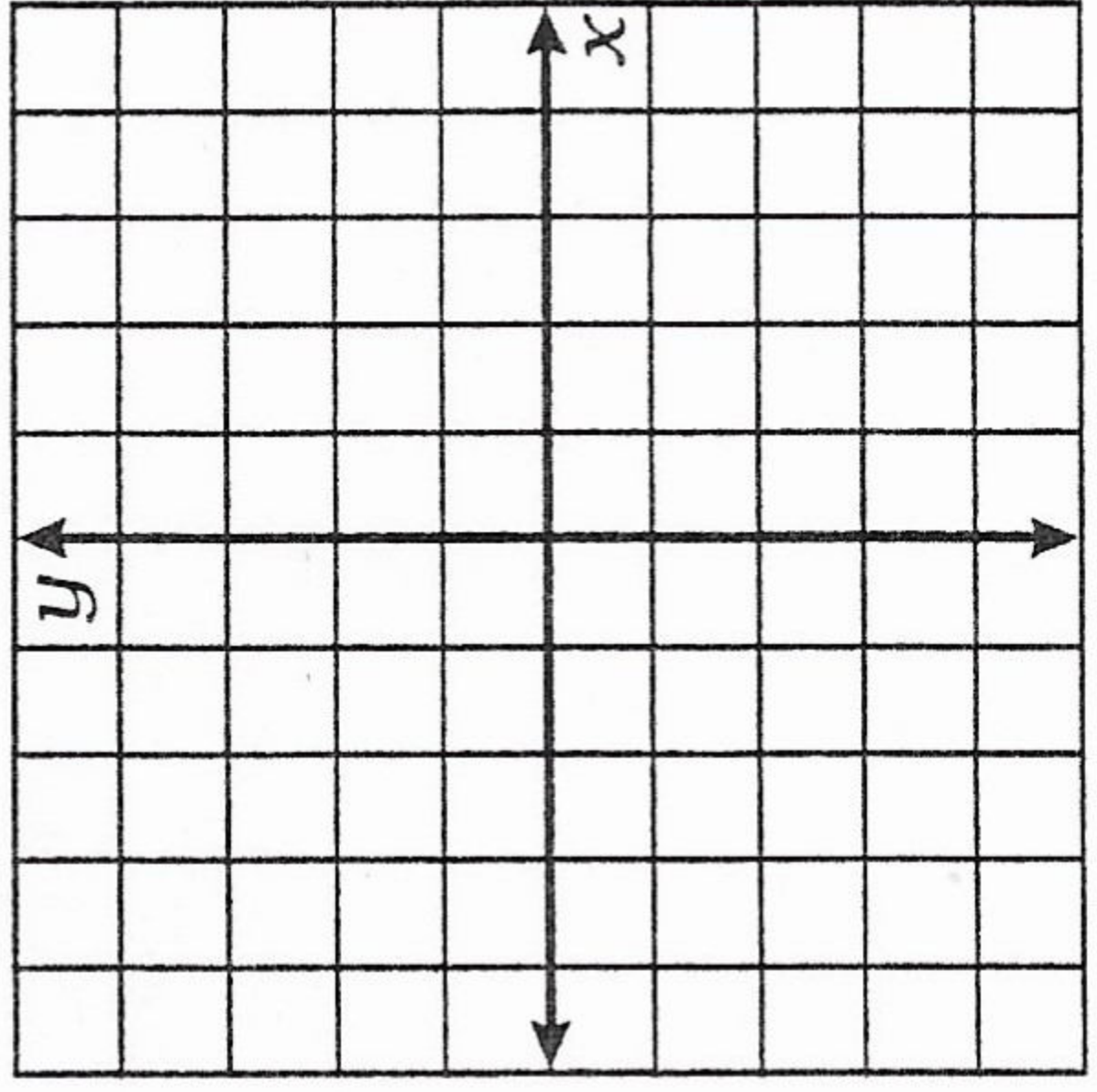

8. $30x + 50y - 100 = 0$
 $3x - 15y - 30 = 0$

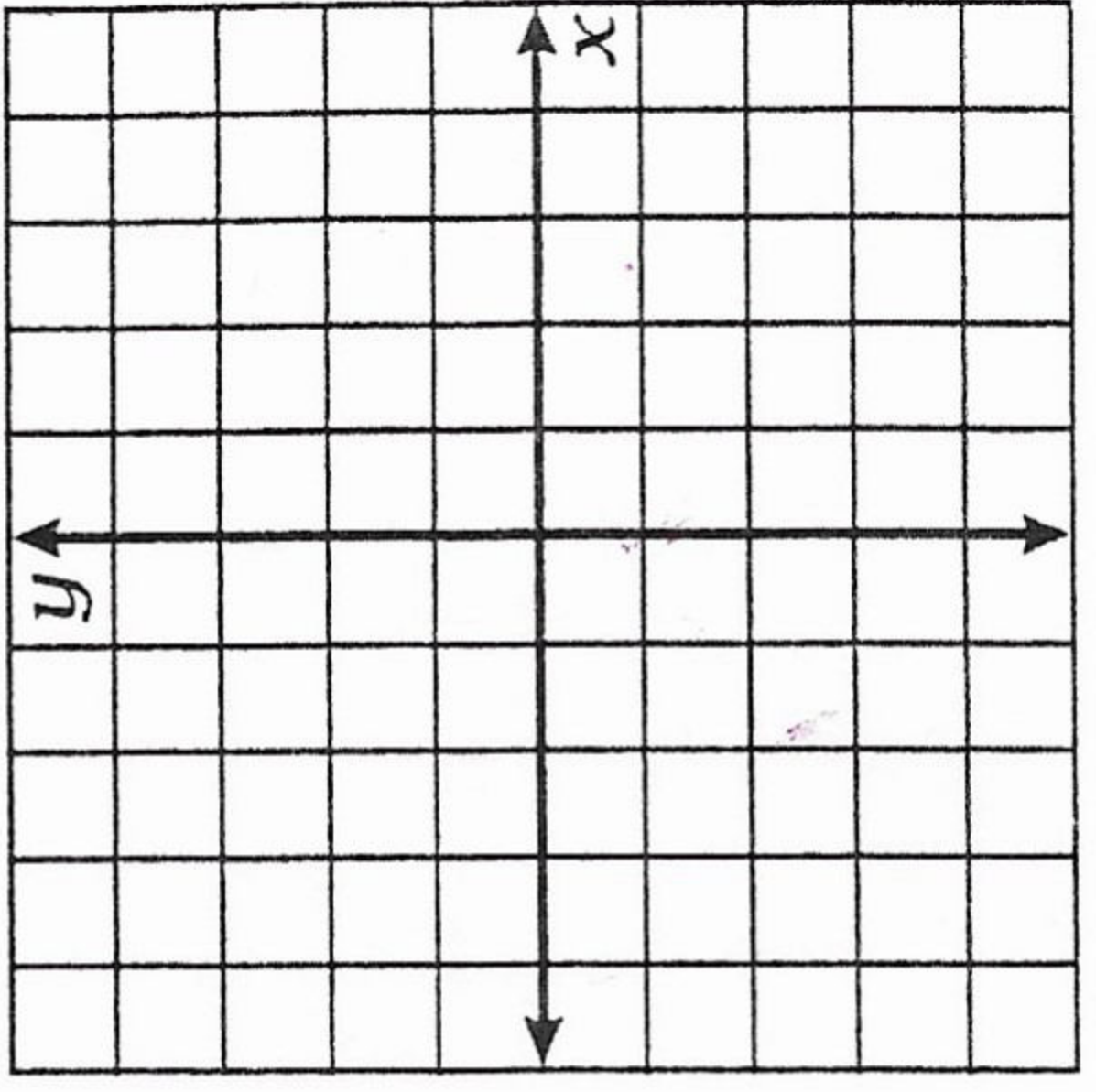

SH	HE	ES	TO	GR	AB	TH	AT	OP	SP	ED	QU	IT
(-3, 1)	(4, 3)	(-4, -1)	(5, -1)	(-2, 4)	(-3, -5)	no solution	(-2, -3)	(2, 2)	(0, -4)	(-4, 0)	(1, -3)	(1, -1)

Cedar Ridge Middle School Math Tournament 2008
7th GRADE TEST

1. How many integers satisfy both $3-x \leq 2$ and $2(x-5) \leq 2$
a. 7 b. infinitely many c. 5 d. 6

2. What is 243 expressed as a binary number?
a. 11110011 b. 101 c. 1011011 d. 11101110

3. What is the slope of the line passing through (2,3) and (-3,2) ?
a. 5 b. 1 c. $\frac{1}{5}$ d. -1

4. A recipe for 12 cupcakes requires $1\frac{1}{2}$ cups of sugar. How many cups of sugar should be used if 20 cup cakes are being made with this same recipe?
a. $2\frac{1}{2}$ b. $2\frac{1}{4}$ c. $2\frac{3}{4}$ d. 2

5. Find the greatest common factor $24a^2b$, $56a^3b^4$, and $72ab^3$
a. $504a^3b^4$ b. $18ab$ c. $12ab^2$ d. $8ab$

6. Of the pieces of Jolly Ranchers candy found in Emmett's locker, 40% were grape, 23.5% were strawberry, 12.5% were peach, 20% were apple, and the other 8 pieces were lemon. How many Jolly Ranchers were found in his locker?
a. 95 b. 100 c. 200 d. 205

7. Lilli and Nora traveled 6 miles east and then 8 miles south in their boat. How far is the boat from its starting point?
a. 48 miles b. 10 miles c. 14 miles d. 2 miles

8. Solve for x. $\frac{5}{8}x = \frac{7}{6}$
a. $-\frac{15}{28}$ b. $\frac{15}{28}$ c. $\frac{28}{15}$ d. $-\frac{28}{15}$

9. $\sqrt[3]{\sqrt{\sqrt{2^{60}}}}$
a. 2^3 b. 2^5 c. 2^4 d. 2^6

10. A rectangle with dimensions 225 by 196 has the same area as a square. What is the perimeter of the square?
a. 210 b. 421 c. 116 d. 840

11. There are nine athletes competing in the track finals. In how many ways can the gold, silver, and bronze medal be awarded?
a. 504 b. 27 c. 362,880 d. 3
12. Bill received a 20% raise each year for three consecutive years, What was his annual salary after three raises if his starting salary was \$1000 per month?
a. \$20,736 b. \$1,600 c. \$17,280 d. \$ 2,000
13. $x @ y = x^2 + 2xy + y^2$ and $x \# y = 3y + 4x$. Find $[4 @ (3 \# 4)]$
a. 761 b. 841 c. 784 d. 836
14. If the average of n numbers is n , then their sum is:
a. $\frac{n}{2}$ b. n^2 c. $2n$ d. n
15. Julia owns 26% of an orchard. Bailey owns 66 acres, and Grace owns the rest. If Julia and Bailey together own 70% of the orchard, how many acres does Grace own?
a. 40 acres b. 50 acres c. 55 acres d. 45 acres
16. 130 is 25% of what number?
a. 520 b. 32.5 c. 105 d. 155
17. Which of the following has the largest value
a. $2x[9-(6-3)]$ b. $2x[(9-6)-3]$ c. $[2x(9-6)]-3$ d. $(2x-9)-(6-3)$
18. Find 35% of 14% of 92
a. 4.58 b. .4508 c. 4.508 d. .04508
19. What is the quotient when 0.48 is divided by 0.016?
a. 0.3 b. 3 c. 30 d. 300
20. If a stack of eight quarters measures exactly one inch, how many inches high would a \$100 stack of quarters be?
a. 50 inches b. 12.5 inches c. 38 inches d. 96 inches
21. How many eighths are in 5.75 ?
a. 23 b. 46 c. 120 d. 63

22. What is the average of $\frac{1}{4}$ and $\frac{1}{6}$?

a. $\frac{5}{12}$

b. $\frac{1}{5}$

c. $\frac{1}{10}$

d. $\frac{5}{24}$

23. If the area of a square is 1024, what is the perimeter of the square?

a. 128

b. 32

c. 256

d. 64

24. In a school of 910 students, the ratio of boys to girls is 5:2. How many more boys than girls are in the school?

a. 650

b. 260

c. 390

d. 455

25. $(\frac{1}{3} - \frac{1}{4}) - (\frac{1}{6} - \frac{1}{12})$

a. $\frac{1}{12}$

b. 0

c. $\frac{1}{6}$

d. 6

Tie Breakers

T1. $\frac{1}{10} + \frac{1}{5} + \frac{1}{10} + \frac{1}{5} + \frac{1}{10} + \frac{1}{5} + \frac{1}{10} + \frac{1}{5} =$

T2. (10% of 20) minus (20% of 10)

T3. Sally drove 238 miles in 4 hours and 15 minutes. What was her average speed in miles per hour?

2008 Hoover HS Math Tournament
Pre-Algebra Written Test

1. If $r > 1$ which one of the following must also be true?

- a) $r + 1 = 2$ b) $r - 1 = 0$ c) $r + 1 > 2$ d) $r = 2$ e)NOTA

2. Evaluate the following: $44 - 33 \div 11 - 1 \times 2$

- a) 27 b) 2 c) 40 d) 39 e)NOTA

3. If $a = b$ and $b = 2c$, find $a + b + c$ when $c = 6$

- a) 18 b) 24 c) 30 d) 36 e)NOTA

4. Solve: $2(2x - 2(2 + 2)) = 8x$

- a) 4 b) 2 c) -2 d) 8 e)NOTA

5. A circle with center at the origin passes through the point $(3, 4)$. What is the diameter of the circle?

- a) 7 units b) 10 units c) 5 units d) 12 units e)NOTA

6. Which quadrant does the graph of $y = -3x - 3$ NOT pass through?

- a) I b) II c) III d) IV e)NOTA

7. The following equation has two answers. What is the sum of the answers? $(a + 2)(a - 2) = 21$

- a) 4 b) 10 c) 7 d) 0 e)NOTA

8. Find the total number of triangles in the drawing.

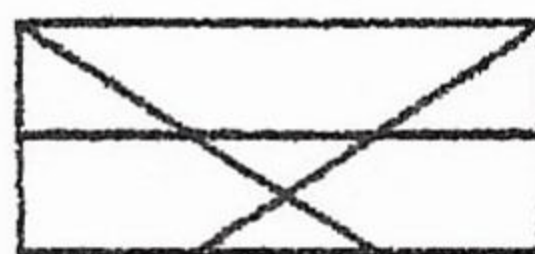

- a) 7 b) 9 c) 4 d) 8 e)NOTA

9. A code to enter a building has a single letter followed by three digits. How many different codes are possible?

- a) 36 b) 326 c) 3026 d) 26000 e)NOTA

10. Find the surface area of a cube that has a volume of $\frac{8}{27} \text{ cm}^3$.

- a) $\frac{8}{3} \text{ cm}^2$ b) 6 cm^2 c) $\frac{1}{3} \text{ cm}^2$ d) $\frac{8}{27} \text{ cm}^2$ e)NOTA

12. How many integer solutions does the equation have? $|2x - 4| < 2$

- a) 6 b) 3 c) 2 d) 1 e)NOTA

Hoover
2008
p.2

13. A boy and a girl want to have a secret meeting. They are 3000 feet apart and walk toward each other at the same time. The boy walks twice as fast as the girl does. If the boy walks 100 feet per minute, how long does it take them to meet?

- a) 30 minutes b) 20 minutes c) 40 minutes d) 10 minutes e)NOTA

14. Two squares are placed as shown. Find the area of the shaded region.

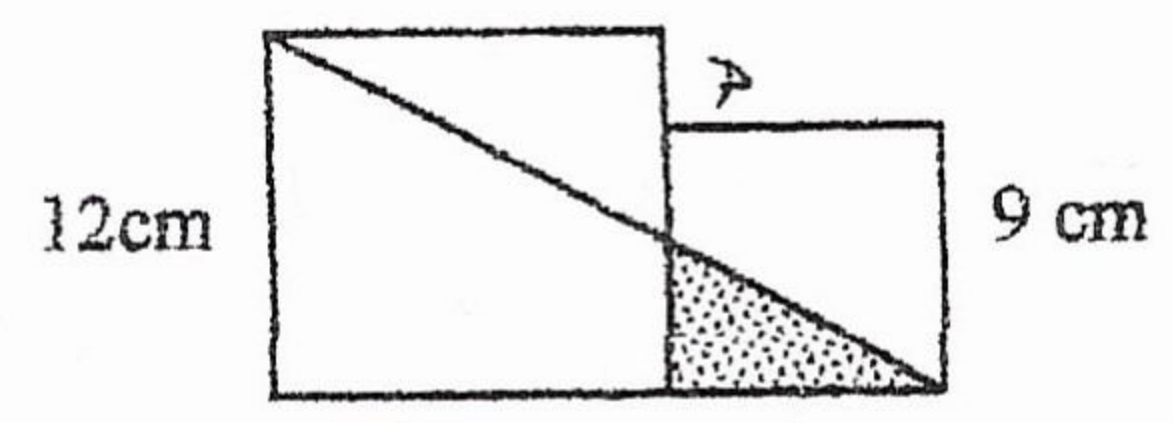

- a) $\frac{81}{4} \text{ cm}^2$ b) 26 cm^2 c) $\frac{162}{7} \text{ cm}^2$ d) $\frac{27}{2} \text{ cm}^2$ e)NOTA

15. Consider the linear equation $y = mx + 12$ and statements I and II:
Which answer choice is true?

- I. The line is parallel to the x axis.
II. The line has a slope of m

- a) Sometimes I
Sometimes II b) Sometimes I
Always II c) Always I
Sometimes II d) Always I
Always II e)NOTA

16. Which one of the following numbers is the mean of the other three numbers? 10, 6, 8, 16

- a) 6 b) 8 c) 10 d) 16 e)NOTA

17. The line $y = 1$ is reflected over the line $x = 1$. The equation of the resulting line is:

- a) $x + y = 2$ b) $y = 1$ c) $y = -1$ d) $x - y = 1$ e)NOTA

18. A segment connecting the origin to the point (12, 5) is rotated 30° counter clockwise to create the shaded shape. Find the area of the shaded region.

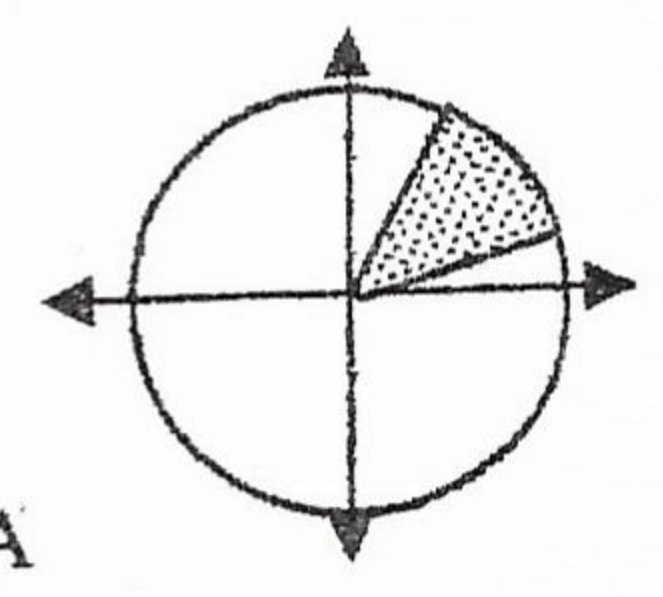

- a) $\frac{169}{12} \pi \text{ units}^2$ b) $\frac{169}{30} \pi \text{ units}^2$ c) $169 \pi \text{ units}^2$ d) $30 \pi \text{ units}^2$ e) NOTA

19. Paul looks back at his life and sees that he spent $\frac{1}{6}$ of his life as a child, $\frac{1}{8}$ of his life as a youth, $\frac{1}{2}$ of his life as a man and the remaining 15 years as an old man. How old is Paul?

- a) 24 b) 96 c) 74 d) 72 e)NOTA

20. The edges of a rectangular prism are in a ratio of 2 : 3 : 5 and the shortest edge has a length of x. Find the ratio of the volume of the prism to its surface area.

- a) $3x : 1$ b) $15x : 62$ c) $10x : 3$ d) $15x : 31$ e)NOTA

21. If Ms. Campbell can grade x papers in y hours. How many hours will it take to grade z papers?

- a) $\frac{xy}{z} \text{ hours}$ b) $xyz \text{ hours}$ c) $\frac{xz}{y} \text{ hours}$ d) $\frac{yz}{x} \text{ hours}$ e)NOTA

23. Soup and salad cost \$12. Salad and a sandwich cost \$13. Soup and a sandwich cost \$11. What would the total cost be if you bought three soups and three salads and three sandwiches?

- a) \$54 b) \$108 c) \$36 d) \$18 e)NOTA

Hoover
2008
p. 3

24. Which of the quadrants of the coordinate plane does not contain an answer to the function: $f(x) = \frac{2}{x-3} - 4$

- a) I b) II c) III d) IV e)NOTA

25. The Braille alphabet uses a series of six dots that are either raised or recessed to form each symbol.



Six dots are always used and form a rectangle as shown. •• Using this information, how many different symbols



can be formed?

- a) 12 b) 24 c) 48 d) 64 e)NOTA

TB1 Find the sum of the first 300 positive integers.

TB2 The 4th root of a number is $\frac{1}{2}$. Find the number.

TB3 Find the sum of the unique, positive, integer factors of 81.

Chapters 1 – 3

Show all work neatly and numbered on your own sheet of paper. Write final answers in the blanks provided.

Simplify.

1. $\frac{30 \div 5 - 2}{2(5 - 3)}$

2. $\frac{-30}{\frac{1}{-2}}$

3. $56 \div 8 - 6 \div 2$

4. $.9 - 1.02 + .54$

5. $-7(-5r - 1) + 2(4 - 3r)$

6. $|3 - 1| - |1 - 3|$

Evaluate each expression if $r = -2$, $s = |-3|$, $t = \frac{1}{3}$, and $v = 6$.

7. $-4r(t + v)$

8. $\frac{st + 4v}{r - 3}$

Solve each equation. If it is an identity or has no solution, say so.

9. $|a| = 8$

10. $|b| = -6$

11. $15 - (5 - n) = 1$

12. $100 - d = 0$

13. $-12j = -84$

14. $4 + \frac{5}{2}(g - 3) = 24$

15. $-5(2h - 1) - 8 = 7$

16. $\frac{2}{5}x + 16 = 0$

17. $-2(3 - b) = 2b + 6$

18. $3(2m - \frac{1}{3}) = 2(3m - \frac{1}{2})$

1. _____ (4)

2. _____ (3)

3. _____ (3)

4. _____ (3)

5. _____ (4)

6. _____ (3)

7. _____ (4)

8. _____ (4)

9. _____ (2)

10. _____ (2)

11. _____ (4)

12. _____ (3)

13. _____ (3)

14. _____ (4)

15. _____ (4)

16. _____ (4)

17. _____ (4)

18. _____ (4)

19. $\frac{5}{6}(7x - 15) = 4x + 4$

19. _____ (4)

★ Solve each equation. You MUST define each unknown quantity, write an equation and solve it. Doing them in a chart is encouraged, but optional. Write the final answer(s) only on the blank provided and include the correct units of measure (label).

20. Six times a number, decreased by five, is -14. Find the number.

20. _____ (5)

21. The longest side of a triangle is 8 cm longer than the shortest side and 5 cm longer than the third side. If the perimeter is 56 cm, find the lengths of all 3 sides.

21. _____ (6)

22. The numbers of fish in Rick and Lisa's aquarium are consecutive integers. When they each had three less fish, together they had 15 fish. How many fish does each have now if Lisa has more fish?

22. _____ (5)

23. When Kate worked 10 h overtime she earned \$8 more than one third the amount she earns for 40 h of work at her usual rate. If her overtime rate is \$2.40 more per hour than her usual rate, find her overtime rate (the amount of money she makes for each overtime hour).

23. _____ (5)

24. Twin Cinema I seats 150 more people than Twin Cinema II. If the cinemas seat 1250 people altogether, find the number of seats in Cinema II.

24. _____ (5)

25. Zach's last test score was 30 points less than twice his first score. What was his first score if the sum of the two scores is 150?

25. _____ (5)

BONUS QUESTION (5pts extra)

On the first of three tests, Katie scored 72 points. On the third test, her score was 1 point more than on the second test. Her average on the three tests was 83. What were her scores on the second and third tests?

_____ (5)

ANSWERS
TO MOST
PAGES

Volume and Surface Area Practice

Answers.

1
5
25
175
625
3125

1
8
64
512

Changing Bases Worksheet (cont)

- ① 50.24 m^3
- ② $49,062.5 \text{ in}^3$
- ③ 803.84 in^3
- ④ $\times 3679.69 \text{ cm}^3$
- ⑤ 56.52 mm^3
- ⑥ 628 ft^3
- ⑦ 1017.36 in^3
- ⑧ 226.08 in^3

- ① 128 cm^3
- ② 160 in^3
- ③ 201.0 m^3
- ④ 5887.5 cm^3
- ⑦ 682.7 cm^3
- ⑧ 962.9 cm^3
- ⑨ 24 in^3

- ① 401.9 cm^2
- ② 88.0 in^2
- ③ 33.5 in^2

- ④ 251.2 cm^2
- ⑤ 156 m^2
- ⑥ 178 ft^2

$$\begin{array}{r} 11 \quad 125 \overline{) 488} \quad 3 \\ 25 \overline{) 113} \quad 4 \\ 5 \overline{) 13} \quad 2 \\ \underline{\quad} \quad 3 \\ 3423_5 \end{array}$$

$$\begin{array}{r} 12 \quad 5 \overline{) 15} \quad 3 \\ \underline{\quad} \quad 0 \\ 30_5 \end{array}$$

$$\begin{array}{r} 13 \quad 125 \overline{) 5017} \quad 1 \\ 625 \overline{) 1892} \quad 3 \\ 125 \overline{) 17} \quad 0 \\ 25 \overline{) 17} \quad 0 \end{array}$$

$$\begin{array}{r} 14 \quad 125 \overline{) 283} \quad 3 \\ 25 \overline{) 8} \quad 0 \\ 5 \overline{) 8} \quad 1 \\ \underline{\quad} \quad 3 \\ 3013_5 \end{array}$$

$$\begin{array}{r} 15 \quad 3125 \overline{) 5000} \quad 1 \\ 625 \overline{) 1876} \quad 3 \\ 125 \overline{) 1} \quad 0 \\ 25 \overline{) 1} \quad 0 \\ 5 \overline{) 1} \quad 0 \\ \underline{\quad} \quad 1 \quad 130001_5 \end{array}$$

$$\begin{array}{r} 25 \overline{) 17} \quad 0 \\ 5 \overline{) 17} \quad 3 \\ \underline{\quad} \quad 2 \\ 130032_5 \end{array}$$

$$\begin{array}{r} 16 \quad 64 \overline{) 247} \quad 3 \\ 8 \overline{) 55} \quad 6 \\ \underline{\quad} \quad 7 \\ 367_8 \end{array}$$

$$\begin{array}{r} 17 \quad 64 \overline{) 317} \quad 4 \\ 8 \overline{) 61} \quad 7 \\ \underline{\quad} \quad 5 \\ 475_8 \end{array}$$

$$\begin{array}{r} 18 \quad 8 \overline{) 56} \quad 7 \\ \underline{\quad} \quad 0 \\ 70_8 \end{array}$$

$$\begin{array}{r} 19 \quad 8 \overline{) 27} \quad 3 \\ \underline{\quad} \quad 3 \\ 33_8 \end{array}$$

$$\begin{array}{r} 20 \quad 512 \overline{) 687} \quad 1 \\ 64 \overline{) 175} \quad 2 \\ 8 \overline{) 47} \quad 5 \\ \underline{\quad} \quad 7 \\ 1257_8 \end{array}$$

Repeating Decimals WS

- ① $\frac{2}{3}$ ② $2\frac{2}{3}$ or $\frac{8}{3}$ ③ $\frac{6}{11}$ ④ $-6\frac{2}{9}$ or $-\frac{56}{9}$
 ⑤ $\frac{5}{11}$ ⑥ $1\frac{2}{3}$ or $\frac{5}{3}$ ⑦ $\frac{7}{15}$ ⑧ $-7\frac{2}{3}$ or $-\frac{23}{3}$
 ⑨ $\frac{4}{15}$ ⑩ $\frac{7}{12}$ ⑪ $\frac{2}{7}$ ⑫ $\frac{10}{11}$
 ⑬ $\frac{2}{9}$ ⑭ $\frac{7}{9}$ ⑮ $\frac{7}{6}$ ⑯ $\frac{8}{9}$
 ⑰ $\frac{8}{15}$ ⑱ $\frac{11}{18}$ ⑲ $\frac{4}{9}$ ⑳ $\frac{1}{3}$
 ㉑ $\frac{47}{6}$ ㉒ $\frac{1}{12}$ ㉓ $-\frac{31}{15}$ ㉔ $\frac{8}{11}$

1	1	32	40	1
4	2	16	8	0
16	4	8	8	1
64	8	4	0	0
256	16	2	0	0
1024	32	1	0	0
4096	64	0	0	0
	128	0	0	0
	256	0	0	0
	512	0	0	0

Changing Bases WS

- ① $32 \overline{) 54} \ 1$
 $16 \overline{) 22} \ 1$
 $8 \overline{) 6} \ 0$
 $4 \overline{) 6} \ 1$
 $2 \overline{) 2} \ 1$
 110110_2
- ② $256 \overline{) 384} \ 1$
 $128 \overline{) 128} \ 1$
 $64 \overline{) 0} \ 0$
 $32 \overline{) 0} \ 0$
 $16 \overline{) 0} \ 0$
 $8 \overline{) 0} \ 0$
 $4 \overline{) 0} \ 0$
 $2 \overline{) 0} \ 0$
 110000000_2
- ③ $8 \overline{) 10} \ 1$
 $4 \overline{) 2} \ 0$
 $2 \overline{) 2} \ 1$
 0
 101_2
- ④ $32 \overline{) 40} \ 1$
 $16 \overline{) 8} \ 0$
 $8 \overline{) 8} \ 1$
 $4 \overline{) 0} \ 0$
 $2 \overline{) 0} \ 0$
 10100_2
- ⑤ $16 \overline{) 38} \ 2$
 $4 \overline{) 6} \ 1$
 2
 212_4
- ⑥ $1024 \overline{) 2048} \ 2$
 $256 \overline{) 1} \ 0$
 $64 \overline{) 1} \ 0$
 $16 \overline{) 1} \ 0$
 $4 \overline{) 1} \ 0$
 1
 200001_4
- ⑦ $4 \overline{) 12} \ 3$
 0
 304
- ⑧ $256 \overline{) 564} \ 2$
 $64 \overline{) 52} \ 0$
 $16 \overline{) 52} \ 3$
 $4 \overline{) 4} \ 1$
 0
 20310_4
- ⑨ $256 \overline{) 388} \ 1$
 $64 \overline{) 132} \ 2$
 $16 \overline{) 4} \ 0$
 $4 \overline{) 4} \ 1$
 0
 12010_4

How Did the Light Dress Up For the Costume Party?

- | | |
|----------------------------|---------------------------|
| 1. $y = \frac{2}{3}x - 4$ | 7. $y = \frac{5}{2}x + 1$ |
| 2. $y = -\frac{1}{2}x + 5$ | 8. $y = -x - 5$ |
| 3. $y = 2x + 3$ | 9. $y = \frac{1}{6}x + 4$ |
| 4. $y = -\frac{4}{3}x - 1$ | 10. $y = -3$ |
| 5. $y = \frac{5}{6}x$ | 11. $y = -4x + 2$ |
| 6. $y = -3x - 6$ | 12. $x = 4$ |

AS A FEATHER

7.11

What Did the Teacher Do With Ogar's Cheese Report?

1. (2, 2)

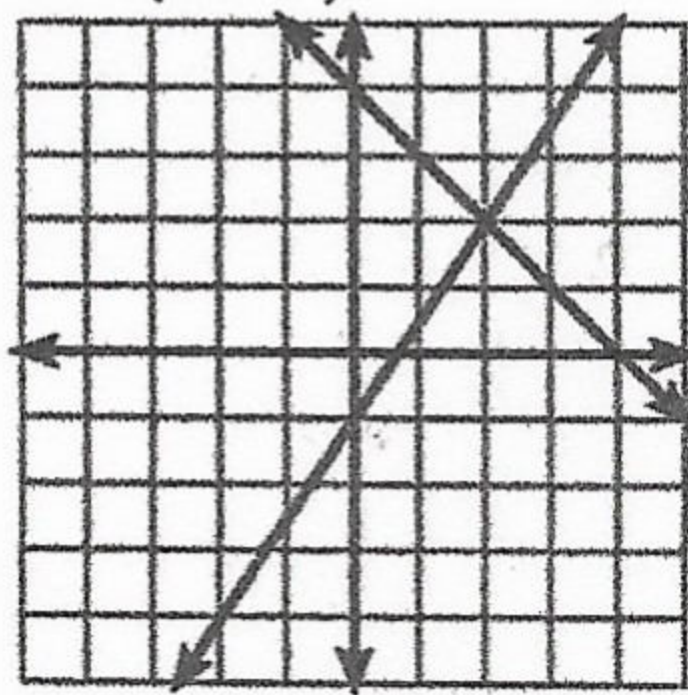

2. (-3, 1)

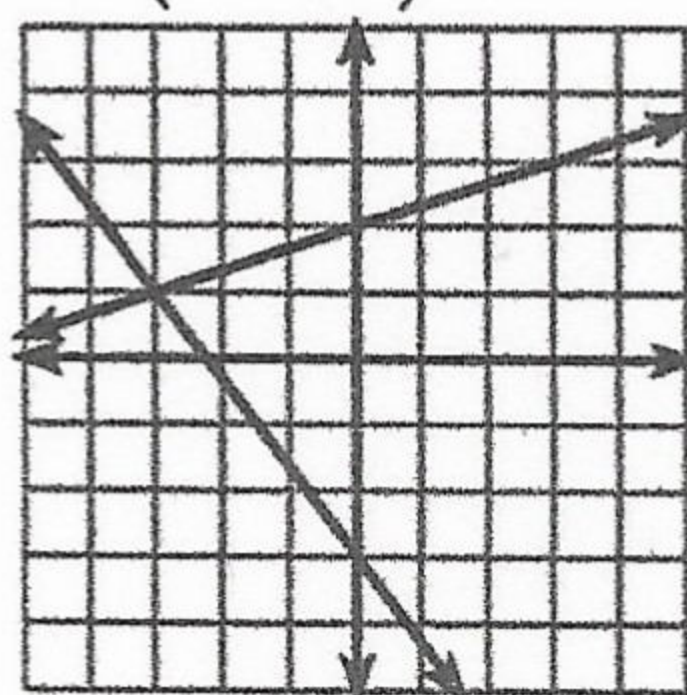

3. (-3, -5)

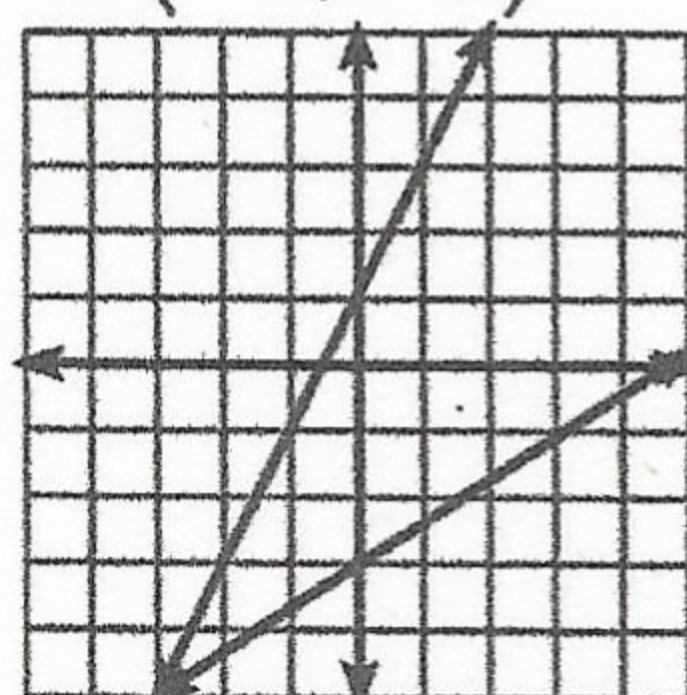

4. (1, -3)

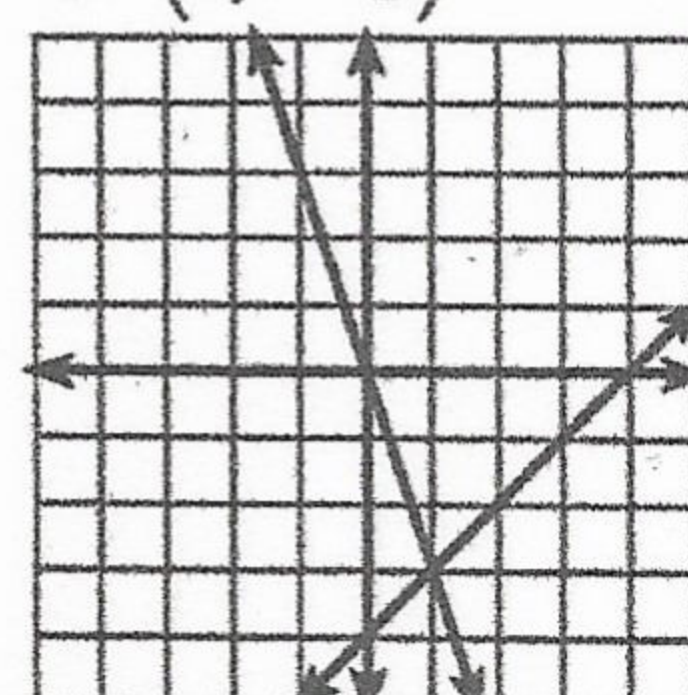

5. (-4, -1)

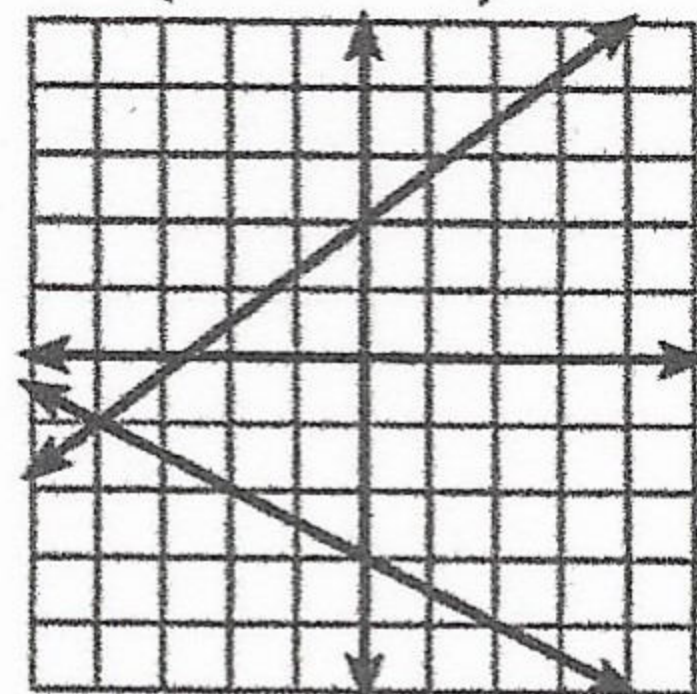

6. (0, -4)

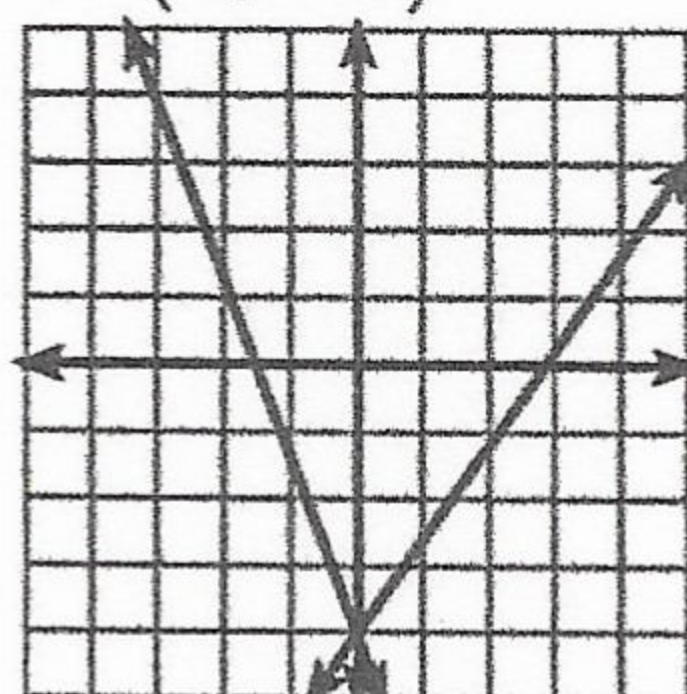

7. no solution

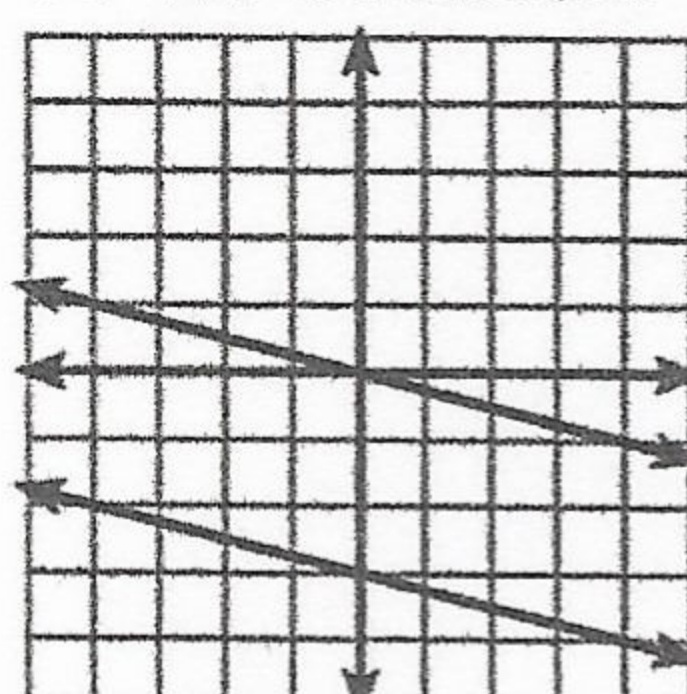

8. (5, -1)

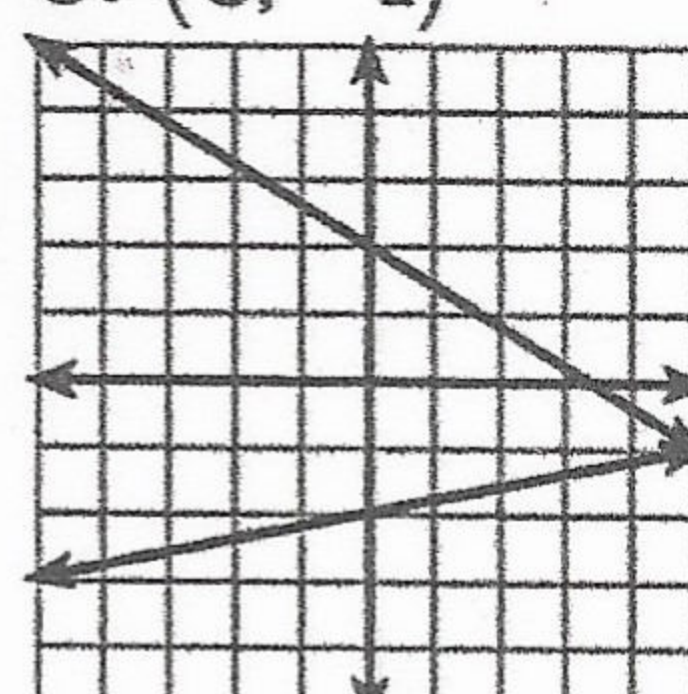

HE GRATED IT

8.1

Cedar Ridge 2008

7th grade written test answers

1. ~~C~~ D
2. A
3. C
4. A
5. D
6. C
7. B
8. C
9. B
10. D
11. A
12. A
13. C
14. B
15. D
16. A
- ~~17. E~~
18. C
19. C
20. A
21. B
22. D
23. A
24. C
25. B

Tie Breakers

#1 $\frac{6}{5}$

#2 0

#3 56

~~4~~ Pre-Algebra

1. C
2. D
3. C
4. E -4
5. B
6. A
7. D
8. A
9. D

10. A
11. A
12. D
13. B
14. C
15. B
16. C
17. B
18. A
19. D
20. B
21. D
22. A
23. A
24. B
25. D

TB1 45150

TB2 $\frac{1}{16}$

TB3 121