

Grade 5

Math

ISTEP+ Part II

Weight **70%**



Robert Trammel
Math Consultant

Message to Teachers

The PowerPoint Presentation is intended to help students to become familiar with online computer-type questions. There are five days of instructional materials that can be easily stretched to six or seven days upon the discretion of the teacher. This PowerPoint Presentation can be used as a whole-class instructional tool or in small group settings. The information is based upon standards by rating:

- ✓ Grade Level Standard Potentially on ISTEP+ Part II only
- * ✓ Grade Level Standard Potentially on ISTEP+ Parts I&II
- * ✓+ Very Important Grade Level Standard Potentially on ISTEP+ Parts I&II
- ✓+ Very Important Grade Level Standard Potentially on ISTEP+ Part II only

Grade 5 Math

Categories and Weight

ISTEP+

- Number Sense 5-14%
- Computation 20-30%
- Algebraic Thinking & Data Analysis 22-32%
- Geometry & Measurement 20-30%
- Mathematical Process 9-19%

Question Types on ISTEP+..... Part II

ISTEP+ Part II has a variety of question types. The samples that are provided in this document will illustrate the different forms or types of problems that you will see on ISTEP+ Part II.

- **Multiple Choice**.....select the one correct answer from a choice of 4.
- **Technology Enhanced**.....select multiple right answers from a list of 5-7 choices.
- **Short Answer**.....answer must be typed on the answer blank provided.
- **Drag and Drop**.....possible answers are in a menu.....drag and drop answer choices with a mouse to a certain location.

Directions:

- The problems that follow will be similar to the types of questions on the online version of ISTEP+.
- Some problems require the use of the ISTEP+ reference sheet. If you see this icon you are allowed to use the ISTEP reference sheet.
- Many of the problems will require some pencil/paper work to find the answer. So....have a pencil and paper handy.

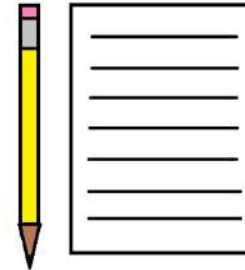
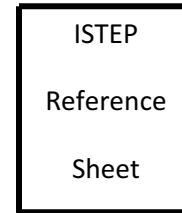
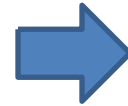

Day 1

Number Sense

4-14%

✓ **5.NS.1**

Use a number line to compare and order fractions, mixed numbers, and decimals to thousandths. Write the results using $>$, $=$, and $<$ symbols.

✓ **5.NS.2**

Explain different interpretations of fractions, including: as parts of a whole, parts of a set, and division of whole numbers by whole numbers.

✓ **5.NS.6**

Understand, interpret, and model percents as part of a hundred (e.g. by using pictures, diagrams, and other visual models).

✓ 5.NS.1

Shown are numbers on a number line from 0 to 20.

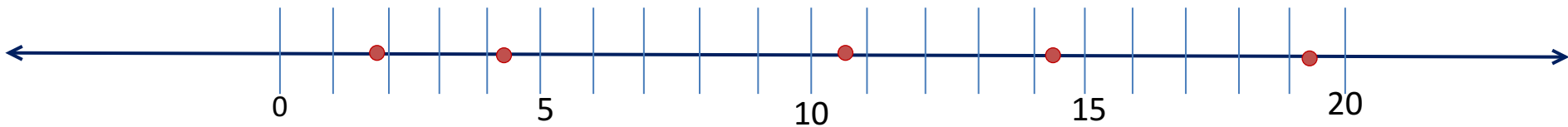

Which two statements are true? Darken two choices.

A $1\frac{3}{4} < 10\frac{1}{2}$

D $19\frac{1}{3} < 14\frac{1}{4}$

B $\frac{21}{2} > 19\frac{1}{3}$

E $4\frac{1}{5} < 1\frac{3}{4}$

C $\frac{57}{4} < 10\frac{1}{2}$

F $4\frac{1}{5} > 1\frac{3}{4}$

✓ 5.NS.2

Which statement is true about $\frac{3}{8} \times \frac{4}{9}$?
Darken the correct letter choice.

- A $\frac{3}{8} \times \frac{4}{9}$ is 3 groups of $\frac{4}{9}$, divided into 8 equal parts.
- B $\frac{3}{8} \times \frac{4}{9}$ is 8 groups of $\frac{4}{9}$, divided into 3 equal parts.
- C $\frac{3}{8} \times \frac{4}{9}$ is 3 groups of $\frac{4}{9}$, divided into 72 equal parts.
- D $\frac{3}{8} \times \frac{4}{9}$ is 8 groups of $\frac{4}{9}$, divided into 12 equal parts.

✓ 5.NS.3

Which of these show 85 percent shaded?
Darken the correct letter choice.

A

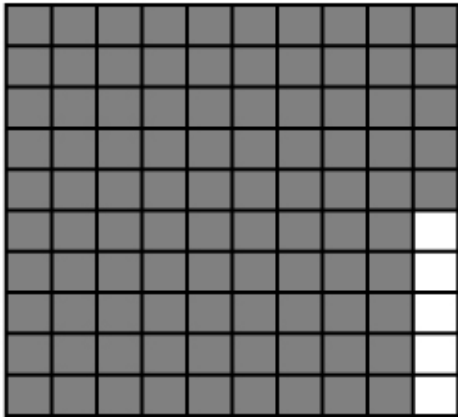

B

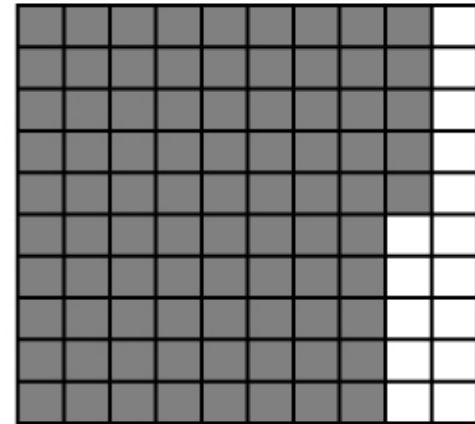

C

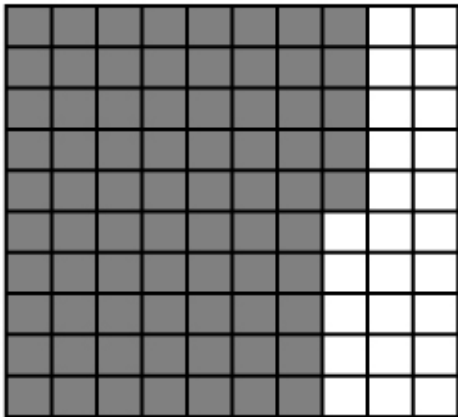

D

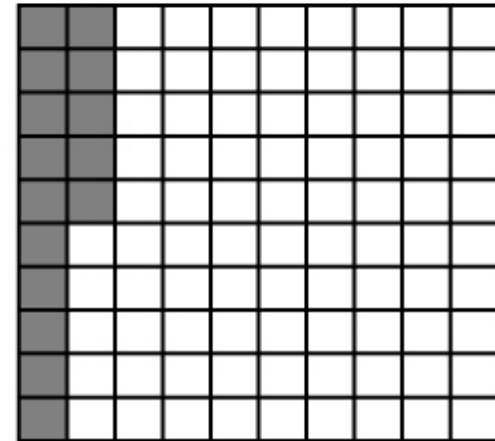

✓ 5.NS.1

Which two statements are true?
Darken two choices.

(A) $10.567 < 10\frac{1}{2}$

(D) $15.565 < 14\frac{1}{4}$

(B) $\frac{23}{4} > 5.75$

(E) $4\frac{1}{5} < \frac{18}{4}$

(C) $\frac{37}{4} < 10\frac{1}{2}$

(F) $7\frac{1}{8} > 7.217$

✓ 5.NS.2

Which statement is true about $\frac{7}{8}$?
Darken the correct letter choice.

(A) $8 - 7$

(B) 7×8

(C) $\frac{8}{7}$

(D) $7 \div 8$

✓ 5.NS.3

What percent of the whole is shaded as shown in the picture?
Write your answer on the blank below.

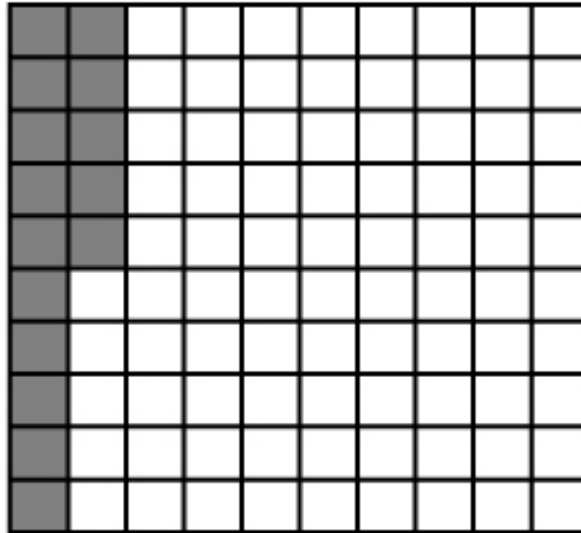

Answer 15%

✓ 5.NS.1

Which comparison shows $5\frac{3}{4}$, $\frac{11}{2}$, and 5.615 from least to greatest?

Darken the correct letter choice.

(A) $\frac{11}{2}$, $5\frac{3}{4}$ and 5.615

(B) 5.615, $\frac{11}{2}$ and $5\frac{3}{4}$

(C) $\frac{11}{2}$, 5.615 and 5

(D) $5\frac{3}{4}$, 5.615 and $\frac{11}{2}$

$\frac{3}{4}$

✓ 5.NS.2

Maria has 4 apple pies and wants to divide them equally among 7 friends. What fraction of a whole pie will each friend get? Darken the correct letter choice.

- A $\frac{4}{7}$ of a whole pie
- B $\frac{7}{4}$ of a whole pie
- C $\frac{11}{4}$ of a whole pie
- D $\frac{3}{7}$ of a whole pie

✓ 5.NS.3

What percent of the whole is shaded as shown in the picture?
Write your answer on the blank below.

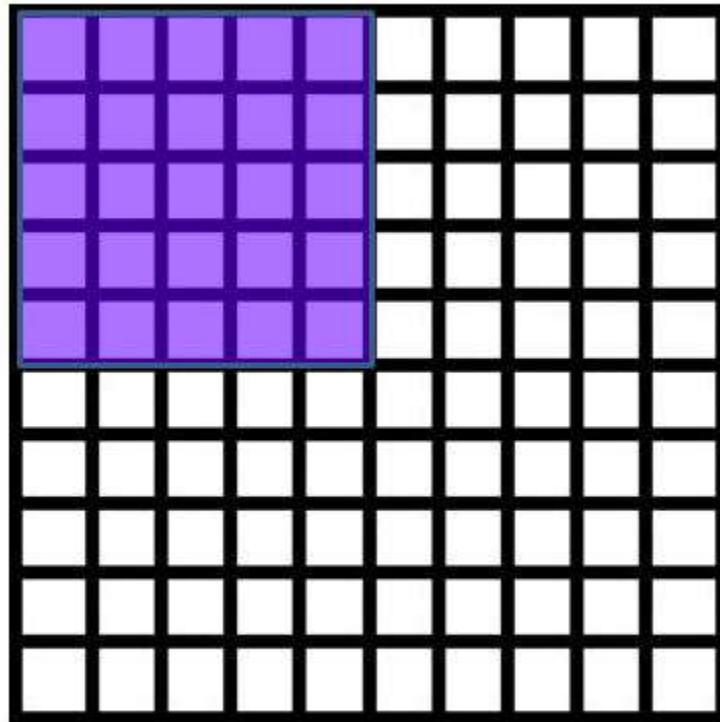

Answer

✓ 5.NS.2

Look at these shapes.

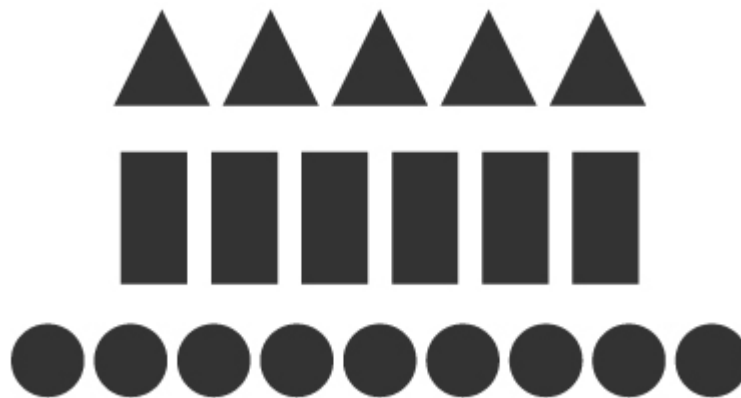

- A $\frac{14}{20}$
- B $\frac{20}{6}$
- C $\frac{6}{14}$
- D $\frac{6}{20}$

Which of these shows the fraction of shapes that are rectangles?
Darken the correct letter choice.

Day 2A

COMPUTATION

20-30%

***✓+ 5.C.1**

Multiply multi-digit whole numbers fluently using a standard algorithmic approach.

✓+ 5.C.2

Find whole-number quotients and remainders with up to four-digit dividends and two-digit divisors, using strategies based on place value, the properties of operations, and/or the relationship between multiplication and division. Describe the strategy and explain the reasoning used.

✓+ 5.C.4

Add and subtract fractions with unlike denominators, including mixed numbers.

✓+ 5.C.5

Use visual fraction models and numbers to multiply a fraction by a fraction or a whole number.

✓+ 5.C.7

Use visual fraction models and numbers to divide a unit fraction by a non-zero whole number and to divide a whole number by a unit fraction.

***✓+ 5.C.8**

Add, subtract, multiply, and divide decimals to hundredths, using models or drawings and strategies based on place value or the properties of operations. Describe the strategy and explain the reasoning.

***✓+ 5.C.9**

Evaluate expressions with parentheses or brackets involving whole numbers using the commutative properties of addition and multiplication, associative properties of addition and multiplication, and distributive property.

***+✓ 5.C.1**

Find the product **493 x 65.**

Darken the correct answer.

A 32,045

B 26,535

C 558

D 5,2423

+✓ 5.C.4

Solve..... $\frac{1}{3} + \frac{5}{8}$

Darken the correct answer.

(A) $\frac{5}{24}$

(B) $\frac{1}{4}$

(C) $\frac{6}{11}$

(D) $\frac{23}{24}$

+✓ 5.C.5

Select two expressions that are equal to $7 \times \frac{3}{8}$.

Darken the correct answers.

(A) $3 \times \frac{1}{56}$

(B) $\frac{3}{7} \times 8$

(C) $21 \times \frac{1}{8}$

(D) $\frac{1}{56} \times 21$

(E) $3 \times \frac{7}{8}$

✓+ 5.C.5

Which problem is shown by the fraction model?
Darken the correct answer.

A

$$\frac{1}{4} + \frac{1}{3} = \frac{7}{12}$$

B

$$\frac{1}{4} - \frac{1}{3} = \frac{1}{12}$$

C

$$\frac{1}{4} \times \frac{1}{3} = \frac{1}{12}$$

D

$$\frac{1}{4} \div \frac{1}{3} = \frac{7}{12}$$

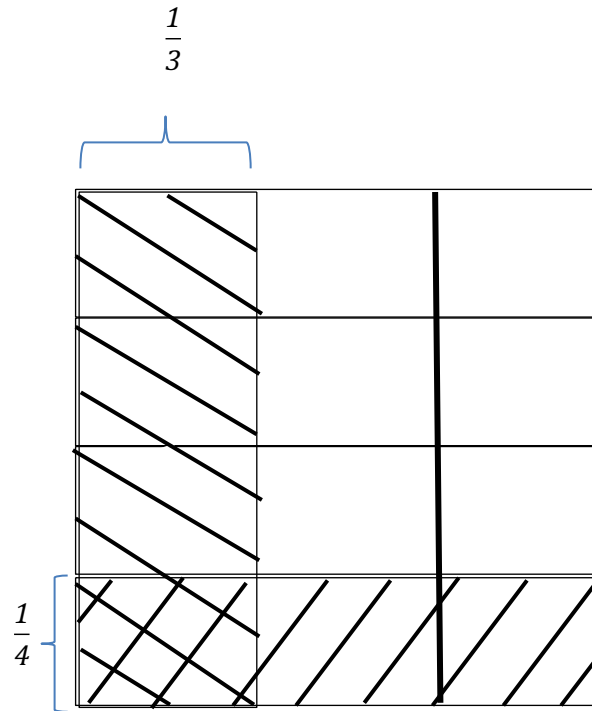

+✓ 5.C.7

Solve..... $\frac{1}{8} \div 5$

Darken the correct answer.

(A) $\frac{1}{40}$

(B) $\frac{1}{13}$

(C) $\frac{5}{8}$

(D) $\frac{40}{1}$

+✓ 5.C.2

Which equation has the same unknown number as $1,148 \div 28 = \square$?
Darken the correct answer.

(A) $1,148 \times \square = 28$

(B) $28 \times \square = 1,148$

(C) $\square \div 28 = 1,148$

(D) $\square \div 1,148 = 28$

+✓+ 5.C.9

What is the value of the expression $(4 \times 3) + (6 + 2)$?
Darken the correct answer.

A 16

B 18

C 20

D 22

Find the product **217 x 34.**
Darken the correct answer.

- A 183
- B 1,519
- C 251
- D 7,378

Solve $- + -$

Darken the letter choice.

A

$$\frac{9}{13}$$

C

$$\frac{51}{13}$$

B

$$\frac{51}{40}$$

D

$$\frac{10}{40}$$

***+✓ 5.C.9**

Select **two** equations that are equivalent.
Darken the correct answers.

(A) $3 \times 2 + 5 = (3 \times 2) + 5$

(B) $15 - 6 + 7 = 15 - (6 + 7)$

(C) $16 - 5 - 2 = 16 - (5 - 2)$

(D) $24 \div 12 \div 6 \div 2 = 24 \div [12 \div (6 \div 2)]$

(E) $3 \times 125 \div 25 + 7 = [3 \times (125 \div 25) + 7]$

✓+ 5.C.5

Which problem is shown by the fraction model?
Darken the correct answer.

A

$$\frac{2}{3} + \frac{1}{4} = \frac{8}{12} + \frac{3}{12} = \frac{11}{12}$$

B

$$\frac{2}{12} - \frac{1}{4} = \frac{8}{12} - \frac{3}{12} = \frac{5}{12}$$

C

$$\frac{2}{3} \times \frac{1}{4} = \frac{2}{12} = \frac{1}{6}$$

D

$$\frac{2}{3} \div \frac{1}{4} = \frac{2}{3} \times \frac{4}{1} = \frac{8}{3}$$

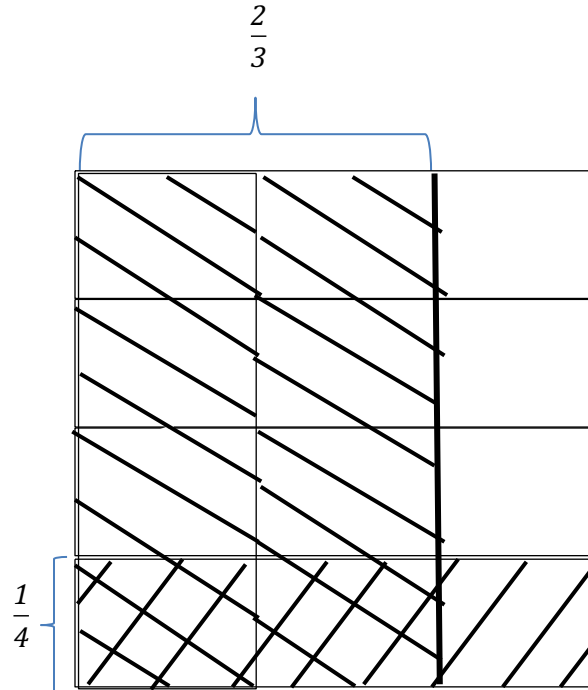

***✓+ 5.C.1**

Find the product of the two numbers
Write your answer on the answer blank below.

$$\begin{array}{r} 2546 \\ \times \quad 42 \\ \hline \end{array}$$

Answer

+✓ 5.C.4

Select the two answers that are equivalent to $\frac{11}{5} - \frac{2}{7}$.

Darken the correct answers.

(A) $\frac{9}{35}$

(B) $\frac{67}{35}$

(C) $\frac{41}{35}$

(D) $1\frac{32}{35}$

(E) $60\frac{7}{35}$

***+✓ 5.C.1 and +✓ 5.C.2**

Select the **two** equations that are correct when the number 200 is entered in the box.
Darken two correct answers.

A $\times 85 = 17,000$

D $1,200 \times 60 =$

B $\div 40 = 50$

E $\times 50 = 1,000$

C $15,000 \div$ $= 75$

✓+ 5.C.2

Write the unknown value in the equation to make the statement true.
Write your answer on the answer blank below.

$$2464 \div \square = 28$$

Answer

+✓ 5.C.7

Solve..... $6 \div \frac{1}{3}$

Darken the correct answer.

A

$$\frac{1}{18}$$

B

$$\frac{1}{2}$$

C

$$2$$

D

$$18$$

✓ 5.C.5

Solve..... — **X** —

Darken the correct answer.

A

$$\frac{14}{16}$$

B

$$\frac{15}{30}$$

C

$$\frac{45}{60}$$

D

$$\frac{50}{54}$$

Day 2B

Solve $5 - - -$

Darken the letter choice.

A

$2\frac{1}{2}$

C

$3\frac{1}{2}$

B

$3\frac{1}{3}$

D

$2\frac{1}{3}$

+✓+ 5.C.9

What is the value of the expression $(4 + 8) \div (2 + 2)$?
Darken the correct answer.

A 3

B 6

C 8

D 10

Solve $16 - - 10 -$

Darken the letter choice.

A

$6\frac{6}{6}$

C

$6\frac{8}{12}$

B

$6\frac{4}{9}$

D

$6\frac{1}{3}$

***✓+ 5.C.9**

Place one set of parentheses () within the expression to make the value 64.

Expression: 7 x 2 + 5 + 15

✓+ 5.C.2

Find the quotient of the two numbers
Write your answer on the answer blank below.

$$1,534 \div 26$$

Answer

+✓ 5.C.7

Which model shows how to find $\frac{1}{3} \div 2 = \frac{1}{6}$ correctly?

Darken the correct answer.

A

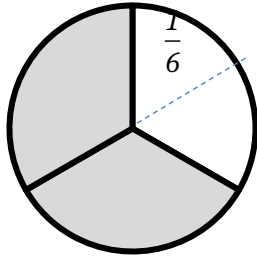

B

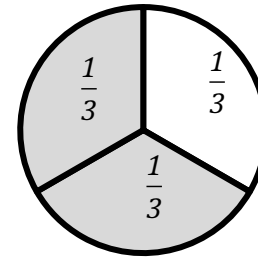

C

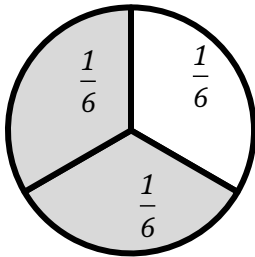

D

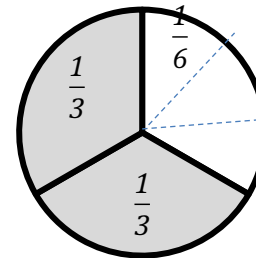

***✓+ 5.C.8**

Find the sum of the two numbers
Write your answer on the answer blank below.

$$5.63 + 14.37$$

Answer

+✓ 5.C.9

What is the value of the expression $4 + 8 \times 2 - 2$?
Darken the correct answer.

A 22

B 20

C 16

D 18

+✓ 5.C.4

An expressions is shown.... — + —

Which expressions have like denominators that could be used as a next step to add the two fractions? Darken two correct answers.

(A) $\frac{5}{6} + \frac{1}{4}$

(D) $\frac{5}{12} + \frac{6}{12}$

(B) $\frac{5}{6} + \frac{3}{6}$

(E) $\frac{5}{12} + \frac{6}{24}$

(C) $\frac{10}{12} + \frac{3}{12}$

(F) $\frac{20}{24} + \frac{6}{24}$

✓+ 5.C.8

What is the value $12.56 + 10.25 + 9.02 + 5.40$?
Write your answer on the answer blank below.

Answer

+✓ 5.C.4

Select the two answers that are equivalent to $\frac{7}{6} - \frac{3}{4}$.

Darken the correct answers.

A

$$\frac{4}{24}$$

B

$$\frac{5}{12}$$

C

$$\frac{4}{2}$$

D

$$\frac{10}{24}$$

E

$$\frac{4}{24}$$

+✓ 5.C.2

A teacher drew an area model to find the value of $6,984 \div 8$.

Teacher's Model for $6,984 \div 8$

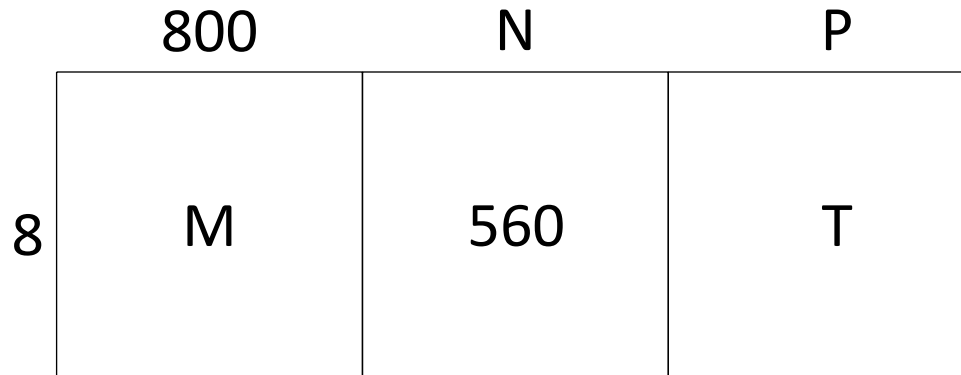

Which are the correct values for **M**, **N**, **P** and **T** for the model?
Select the correct letter choice.

- (A) M = 6400 N = 70 P = 3 T = 24
- (B) M = 6400 N = 3 P = 70 T = 24
- (C) M = 640 N = 24 P = 3 T = 70
- (D) M = 640 N = 70 P = 3 T = 24

+✓ 5.C.4

Solve $1 - \frac{2}{5} - \frac{1}{10}$ — Darken the letter choice.

A

$$1 \frac{7}{20}$$

C

$$1 \frac{7}{19}$$

B

$$3 \frac{17}{20}$$

D

$$5 \frac{4}{20}$$

*✓+ 5.C.8

Find the product of the two numbers
Write your answer on the answer blank below.

$$0.35 \times 1.5$$

Answer

***✓+ 5.C.9**

Evaluate the expression.
Write your answer on the answer blank below.

$$3 \times (8 + 16) \div 4$$

Answer

+✓ 5.C.7

Look at this fraction model.

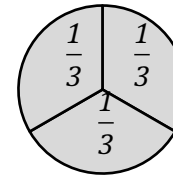
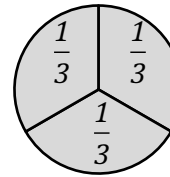

Which statement describes this model?
Darken the correct answer.

A $\frac{1}{3} \div 2 = 6$

B $2 \times 3 = 6$

C $2 \div \frac{1}{3} = 6$

D $3 \times 2 = 6$

✓ + 5.C.4

Drag and drop the correct fraction to the answer blank from the Selection Menu to make each statement true.

Not all the fractions in the Selection Menu will be used.

1. $\frac{4}{6} - \frac{1}{2} =$ _____

2. $2\frac{1}{6} - 1\frac{2}{3} =$ _____

3. $\frac{5}{8} + \frac{7}{16} =$ _____

4. $2\frac{5}{6} + 1\frac{2}{3} =$ _____

Selection Menu

$$\frac{1}{2} \qquad \frac{1}{4}$$

$$\frac{1}{6} \qquad 1\frac{1}{16}$$

$$4\frac{1}{6} \qquad 4\frac{1}{2}$$

Day 3A

Algebra Functions & Data Analysis

22-32%

***✓+ 5.AT.1**

Solve real-world problems involving multiplication and division of whole numbers (e.g. by using equations to represent the problem). In division problems that involve a remainder, explain how the remainder affects the solution to the problem.

***✓+ 5.AT.2**

Solve real-world problems involving addition and subtraction of fractions referring to the same whole, including cases of unlike denominators (e.g., by using visual fraction models and equations to represent the problem). Use benchmark fractions and number sense of fractions to estimate mentally and assess whether the answer is reasonable.

***✓ 5.AT.3**

Solve real-world problems involving multiplication of fractions, including mixed numbers (e.g., by using visual fraction models and equations to represent the problem).

✓ 5.AT.4

Solve real-world problems involving division of unit fractions by non-zero whole numbers, and division of whole numbers by unit fractions (e.g., by using visual fraction models and equations to represent the problem).

***✓+ 5.AT.5**

Solve real-world problems involving addition, subtraction, multiplication, and division with decimals to hundredths, including problems that involve money in decimal notation (e.g. by using equations to represent the problem).

✓ 5.AT.7

Represent real-world problems and equations by graphing ordered pairs in the first quadrant of the coordinate plane, and interpret coordinate values of points in the context of the situation.

✓+ 5.AT.8

Define and use up to two variables to write linear expressions that arise from real-world problems, and evaluate them for given values.

***✓+ 5.AT.2**

Diana works at a clothing store. She sold $\frac{1}{5}$ of the total number of green shirts on

Monday and $\frac{3}{12}$ of the total number of green shirts on Tuesday.

What fraction of green shirts did Diana sell on Monday and Tuesday?
Darken the correct answer.

(A) $\frac{8}{13}$

(B) $\frac{4}{17}$

(C) $\frac{5}{36}$

(D) $\frac{27}{60}$

***✓+ 5.AT.2**

Diana works at a clothing store. She sold $\frac{1}{5}$ of the total number of green shirts on Monday and $\frac{3}{12}$ of the total number of green shirts on Tuesday.

Diana sold $\frac{2}{12}$ of the total number of green shirts on Wednesday.

What is the difference in the fraction of the total number of green shirts that were sold on Tuesday and Wednesday? Darken the correct letter choice.

- (A) $\frac{7}{60}$
- (B) $\frac{5}{27}$
- (C) $\frac{1}{3}$
- (D) $\frac{1}{12}$

***✓+ 5.AT.1**

For a family gathering, Brittany made 5 meat loaves using 9 pounds of ground beef. She also made 14 hamburgers using 4 pounds of ground beef. Each meat loaf was made with the same amount of ground beef.

Which of these is closest to the amount of ground beef in each meat loaf?
Darken the correct letter choice.

- A $\frac{1}{2}$ pound
- B 1 pound
- C $1\frac{1}{2}$ pound
- D 2 pounds

***✓+ 5.AT.1**

For a family gathering, Brittany made 5 meat loaves using 9 pounds of ground beef. She also made 14 hamburgers using 4 pounds of ground beef. Each hamburger was made with the same amount of ground beef.

Which of these is closest to the amount of ground beef in each hamburger?
Darken the correct letter choice.

- A $\frac{1}{2}$ pound
- B $\frac{1}{4}$ pound
- C $\frac{3}{4}$ pound
- D 1 pound

*✓+ 5.AT.1

Greg is volunteering at a track meet. He is in charge of providing the bottled water.

Greg knows these facts:

- There will be 117 athletes, 7 coaches, and 4 judges attending the track meet.
- One case of bottled water contains 24 bottles.

The table shows the number of bottles of water each athlete, coach, and judge will get for the track meet.

Bottle Water for Track Meet	
Person Attending	Number of Bottle Waters
Athlete	4
Coach	3
Judge	2

What is the **fewest** number of cases of bottled water Greg will need to provide for all the athletes, coaches, and judges at the track meet? Darken the correct letter choice.

- A 497 cases
- B 497 cases
- C 20 cases
- D 21 cases

Day 3B

✓ 5.AT.7

Select the **three** statements that correctly describe the point plotted on the coordinate plane.

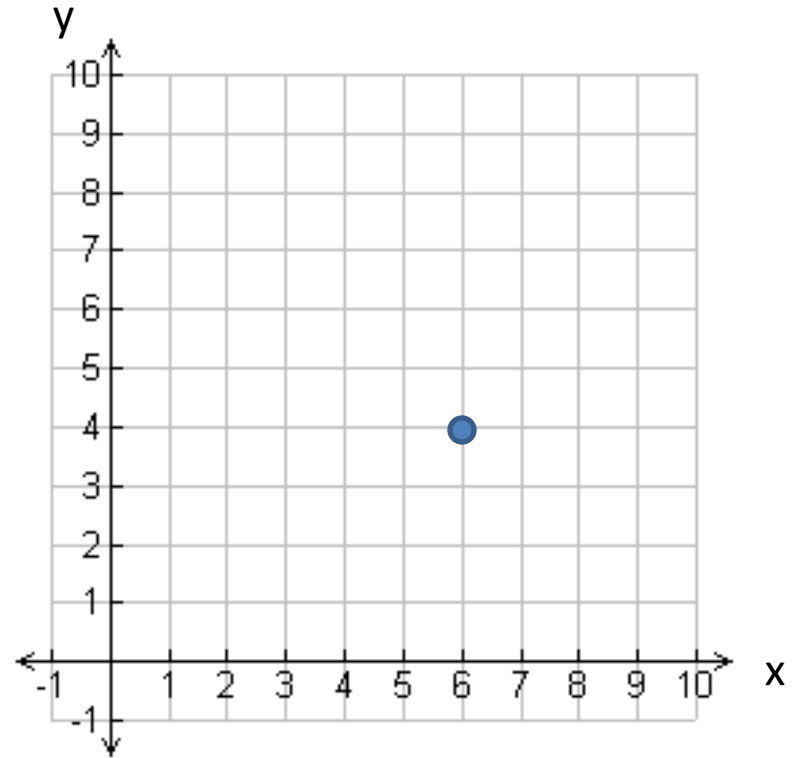

- A The point is located at the ordered pair (4, 6).
- B The point is located at the ordered pair (6, 4).
- C The x-coordinate is 6 and the y-coordinate is 4.
- D The x-coordinate is 4 and the y-coordinate is 6.
- E The point is 4 units to the right of the origin on the x-axis and 6 units up from the origin on the y-axis.
- F The point is 6 units to the right of the origin on the x-axis and 4 units up from the origin on the y-axis.

*✓+ 5.AT.2

Len walks $\frac{3}{10}$ mile in the morning to school.

He walks $\frac{2}{5}$ mile in the afternoon to a friend's house.

Which **two** statements are true? $\frac{5}{15}$ mile in the morning and afternoon.

- (A) Since $\frac{3}{10}$ plus $\frac{2}{5}$ is $\frac{5}{15}$, the total of $\frac{5}{15}$ is reasonable.
- (B) Since $\frac{5}{15}$ less than $\frac{2}{5}$, the total of $\frac{5}{15}$ is not reasonable.
- (C) The fractions $\frac{5}{15}$, $\frac{3}{10}$, and $\frac{2}{5}$ are all less than $\frac{1}{2}$, so that the total of $\frac{5}{15}$ is reasonable.
- (D) The fractions $\frac{5}{15}$ is $\frac{1}{3}$ and $\frac{1}{3}$ is greater than $\frac{3}{10}$. Since $\frac{5}{15}$ is greater than one of the addends, the total of $\frac{5}{15}$ is reasonable.
- (E) The fractions $\frac{3}{10}$ and $\frac{2}{5}$ are each greater than $\frac{1}{4}$, so the total must be greater than $\frac{1}{2}$.
The fraction $\frac{5}{15}$ is less than $\frac{1}{2}$, so that the total of $\frac{5}{15}$ is not reasonable.

***✓+ 5.AT.1**

This table shows the three different ways that toy animals are packaged at a factory.

Package Type	Amount in the Package
Bag	36 toy animals
Box	48 bags
Crate	18 boxes



1 Crate = 18 boxes



1 Box = 48 bags



1 bag = 36 toys

What is the total number of toy animals in one crate?
Darken the correct letter choice.

- A 31,104 toys
- B 102 toys
- C 1,728 toys
- D 864 toys

***✓+ 5.AT.2**

Isabel lives $\frac{3}{4}$ mile from school. Janet lives $\frac{2}{3}$ mile from school.

How much farther, in miles, does Isabel live from school than Janet?

Place your answer on the answer blank below.

Answer  _____ miles

Valerie had 18 pieces of paper to give to her friends “b”. She gave an equal number of pieces of paper to each friend. Which of these expressions shows how many pieces of paper Valerie gave to each of her friends? Darken the correct letter choice.

(A) $18 + b$

(B) $18 \times b$

(C) $18 - b$

(D) $18 \div b$

***✓+ 5.AT.5**

Libby went shopping at a local department store. She noticed the items on sale.

Libby decided to purchase 2 pairs of jeans and 3 tank tops. She paid for the purchase with a \$100 bill. How much change did Libby get back from the clerk? Darken the correct letter choice.

- A \$10.60
- B \$10.50
- C \$9.40
- D \$9.60

Hill's Department Store
ON SALE
NO SALES TAX TODAY!

Jeans	\$25.50 each
Blouses	\$17.80 each
Tank Tops	\$12.80 each

*✓+ 5.AT.2

A community center has three swimming pools. The water level of each pool is measured at 8:00 p.m. each night. Two of the measurements from Saturday night are shown.

- The water level in the first pool is $3\frac{5}{12}$ feet deep.
- The water level in the second pool $4\frac{3}{4}$ is feet deep.

What is the difference in depth, in feet, between the water levels of the second pool and the first pool? Darken the correct letter choice.

(A) $1\frac{1}{4}$ feet

(B) $1\frac{1}{16}$ feet

(C) $\frac{11}{12}$ feet

(D) $\frac{23}{24}$ feet

*✓+ 5.AT.2

A community center has three swimming pools. The water level of each pool is measured at 8:00 p.m. each night. Two of the measurements from Saturday night are shown.

- The water level in the first pool is $3\frac{5}{12}$ feet deep.
- The water level in the second pool $4\frac{3}{8}$ is feet deep.

The water level in the third pool is $2\frac{3}{4}$ feet deeper than the second pool.

What is the total depth, in feet, of the water level in the third pool?

Darken the correct letter choice.

A $6\frac{3}{8}$ feet

B $6\frac{1}{2}$ feet

C $7\frac{1}{8}$ feet

D $7\frac{3}{4}$ feet

***✓+ 5.AT.1**

Emma has a board that is 5 feet long. She cuts the board into 6 equal pieces. Which equation shows how to find the length, in feet, of each piece of the board? Darken the correct letter choice.

A $5 \times 6 = 30$

B $6 - 5 = 1$

C $6 \div 5 = 1\frac{1}{5}$

D $5 \div 6 = \frac{5}{6}$

***✓+ 5.AT.2**

Alex put $\frac{4}{7}$ of the money he earned in the bank. He spent $\frac{1}{3}$ of the money on a book.

Which expression can be used to find the difference between the fraction of money Alex put in the bank and the fraction of money he spent on the book?
Darken the correct letter choice.

(A) $\frac{4}{10} - \frac{1}{10}$

(B) $\frac{8}{10} - \frac{7}{10}$

(C) $\frac{4}{21} - \frac{1}{21}$

(D) $\frac{12}{21} - \frac{7}{21}$

✓ 5.AT.7

Joy rides her bike to school every day. She starts from her home located at point A (1, 1), travels to her friend Sally's home at point B (3, 4), and then reaches her school located at point C (7, 6).

Which graph correctly plots the locations Joy rides to?
Darken the correct letter choice.

A

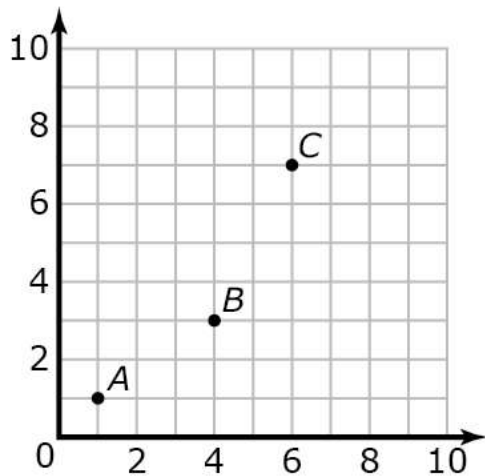

B

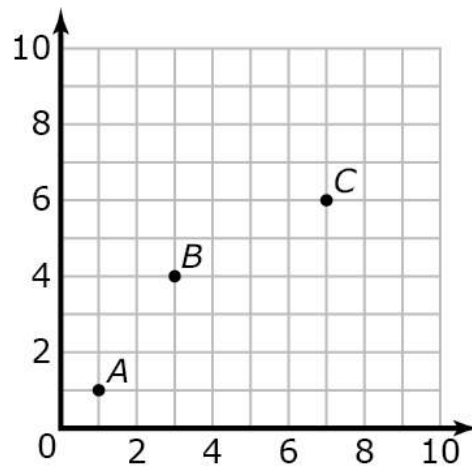

C

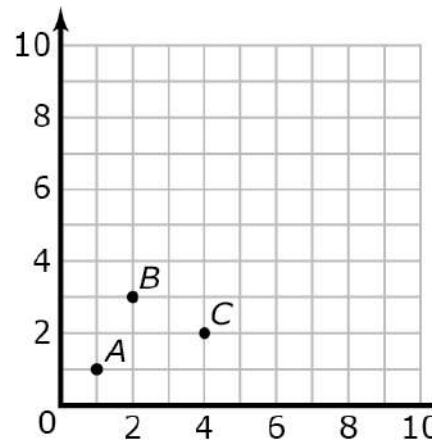

D

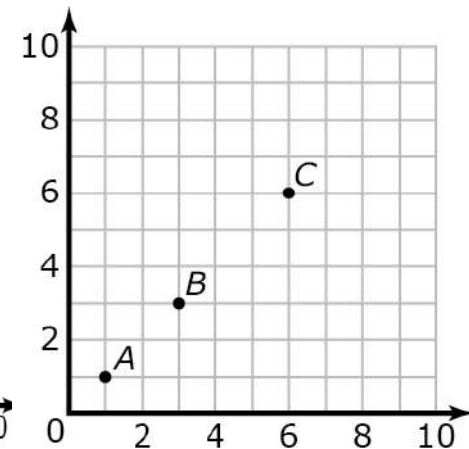

✓ 5.AT.7

A student plots the following points:

- Point A (3, 5)
- Point B (1, 2)
- Point C (4, 6)
- Point D (5, 7)
- Point E (9, 6)

Darken **all** the points that were plotted correctly.

- A Point A
- B Point B
- C Point C
- D Point D
- E Point E

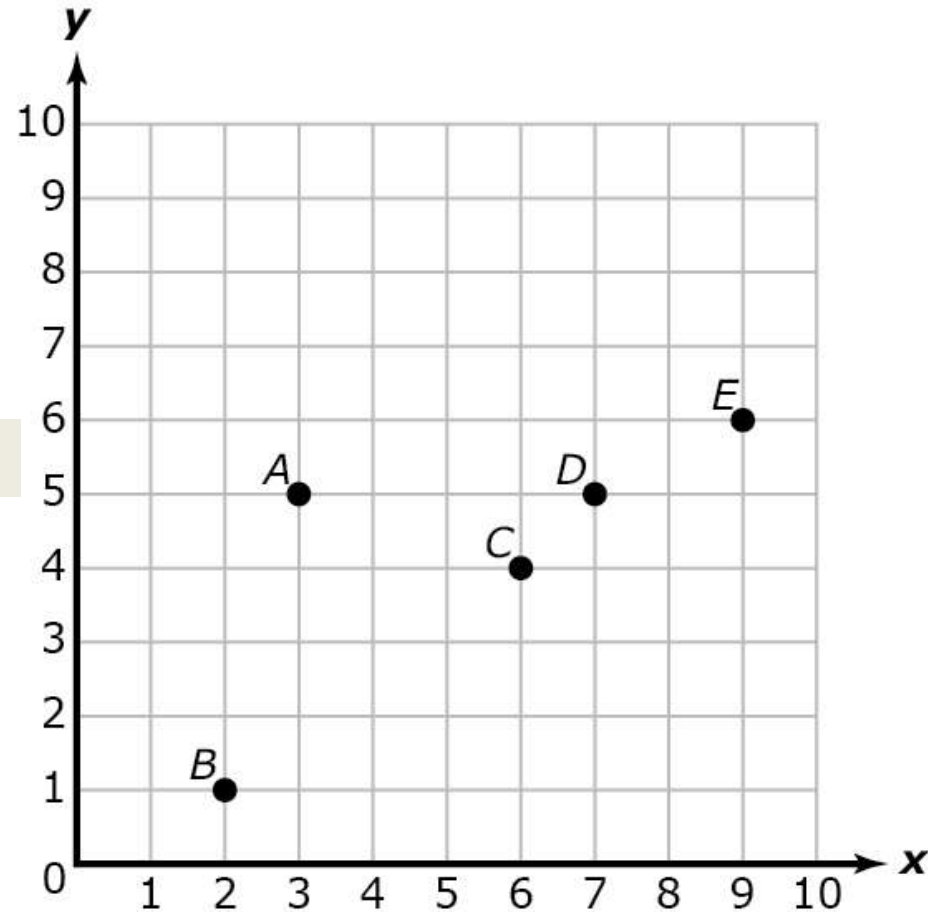

*✓ 5.AT.3

John travels $7\frac{5}{6}$ miles to reach school. Albert travels $\frac{1}{3}$ the distance of miles John travels to reach the same school. How far is the school from Albert's house? Darken the correct letter choice.

(A) $2\frac{11}{18}$ miles

(B) $7\frac{5}{18}$ miles

(C) $7\frac{1}{2}$ miles

(D) $2\frac{1}{6}$ miles

Day 3B

***✓+ 5.AT.1**

There are 128 students going on a field trip. Each bus used will have an equal number of students.

Select the **two** answers that could represent the number of students in each bus and the total number of buses used.

- (A) 42 students on each bus and 3 buses
- (B) 32 students on each bus and 4 buses
- (C) 16 students on each bus and 8 buses
- (D) 21 students on each bus and 6 buses
- (E) 14 students on each bus and 9 buses

***✓ 5.AT.4**

How many $\frac{1}{4}$ cup servings are there in a 6 cup carton of juice?

Darken the correct letter choice.

A $\frac{1}{24}$

B $1\frac{1}{2}$

C 24

D 28

✓ 5.AT.7

The graph shows the location of Jack's home, his school, and the library.

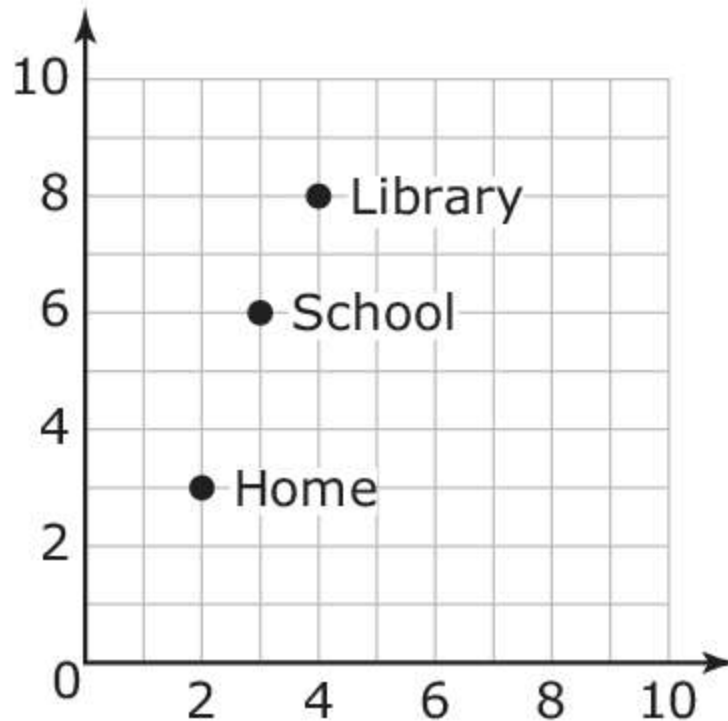

What is the x-coordinate of the point that represents the library?
Write your answer on the answer blank.

Answer

***✓+ 5.AT.5**

Libby went shopping at a local department store. She noticed the items on sale.

Libby decided to purchase 1 pair of jeans and 2 blouses. How much was this purchase before taxes? Darken the correct letter choice.

Hill's Department Store	
ON SALE	
Jeans	\$25.50 each
Blouses	\$17.80 each
Tank Tops	\$12.80 each

- A \$43.30
- B \$60.30
- C \$61.10
- D \$42.30

✓+ 5.AT.8

Last week, Rory earned \$6.57 for every hour that she worked at the fabric store. At the end of the week, her boss gave her a bonus of \$8.00. Which of these expressions can Rory use to find out how much money she made last week, if n is the number of hours she worked? Darken the correct letter choice.

- A $\$6.57 \times n + \8.00
- B $\$6.57 \times n \times \8.00
- C $\$6.57 + n + \8.00
- D $\$6.57 \times \$8.00 + n$

***✓+ 5.AT.1**

A school district ordered 2,832 new chairs. There are 24 schools in the district. If they share the new chairs equally, how many chairs will each school receive? Darken the correct letter choice.

- A 11
- B 118
- C 1,180
- D 117

***✓ 5.AT.4**

Brett has $\frac{1}{3}$ of his birthday cake left. If he divides it among 5 people, how much cake does each person get? Darken the correct letter choice.

A 15

B $1\frac{2}{3}$

C $\frac{3}{5}$

D $\frac{1}{15}$

***✓+ 5.AT.1**

A teacher shares 20 chocolates with the 6 students helping in her classroom. Each student gets the same number of chocolates.

How many chocolates does the teacher have left over?
Darken the correct letter choice.

A 2

B 3

C 6

D 14

✓+ 5.AT.8

There are 52 students in the 6th grade at Lincoln Middle School.

- There are 25 girls in the 6th grade.
- Let b be the number of boys in the 6th grade.

If 5 more boys joined, what expression can be used to find the number of boys in the 6th grade? Darken the correct letter choice.

- (A) $b = 52 - 25$
- (B) $b = 52 - 25 + 5$
- (C) $b = 52 - 25 - 5$
- (D) $b = 52 + 25 + 5$

✓ + 5.AT.8

Drag and drop the correct numbers from the Selection Menu to make the equation true.

Not all the numbers in the Selection Menu will be used.

$$8 \div (\text{_____} + \text{_____}) = 1$$

Selection Menu

5 8

7 2

10 3

***✓ 5.AT.3**

Jamie had 24 cars. Of the 24 cars, $\frac{2}{3}$ of the cars are red.

How many of the cars are red? Darken the correct letter choice.

- (A) 12 cars are red
- (B) 13 cars are red
- (C) 14 cars are red
- (D) 16 cars are red

✓ 5.AT.7

The graph shows the locations of a library, a cafeteria, an auditorium, and a playground.

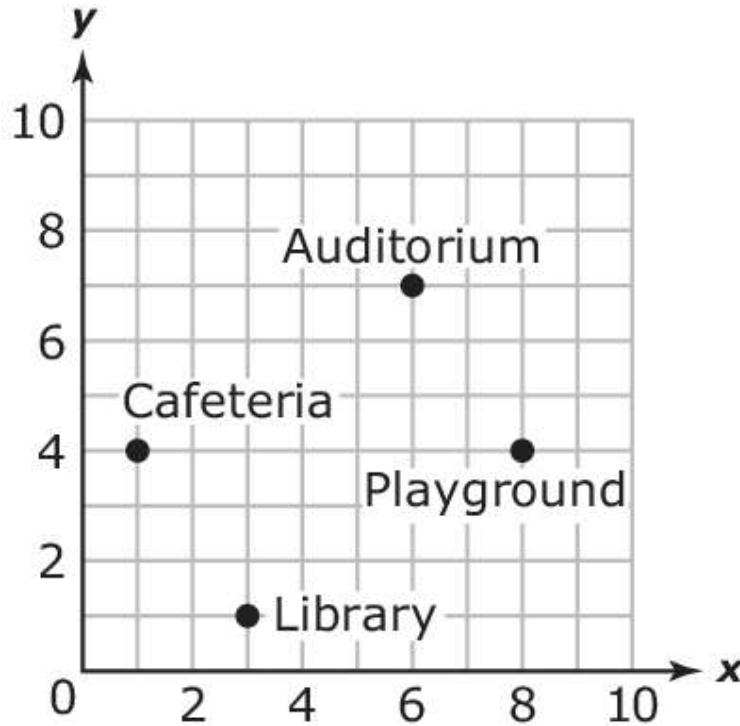

Write the numbers to show the coordinate pair representing the location of the auditorium. Write your answer on the answer blank.

Answer

***✓+ 5.AT.5**

Libby went shopping at a local department store. She noticed the items on sale.

Libby decided to purchase 3 pairs of jeans, 2 blouses, and 1 tank top. How much did this purchase cost Libby? Darken the correct letter choice.

Place your answer on the answer blank.

Hill's Department Store
ON SALE
NO SALES TAX TODAY!

Jeans \$25.50 each

Blouses \$17.80 each

Tank Tops \$12.80 each

Answer \$ _____

***✓ 5.AT.3**

A favorite meatloaf recipe my grandmother used to make required $2\frac{3}{4}$ pounds of hamburger, $\frac{1}{2}$ of a teaspoon of salt, and 3 eggs. Grandmother wants to triple (3 times) the meatloaf recipe for a family reunion.

With the recipe tripled, how many pounds of hamburger will be needed?
Place your answer on the answer blank below.

Answer pounds of hamburger

Day 3C

*✓ **5.DS.1**

Formulate questions that can be addressed with data and make predictions about the data. Use observations, surveys, and experiments to collect, represent, and interpret the data using tables (including frequency tables), line plots, bar graphs, and line graphs. Recognize the differences in representing categorical and numerical data.

✓ **5.DS.2**

Understand and use measures of center (mean and median) and frequency (mode) to describe a data set.

***✓ 5.DA.1**

At Sara's party, her guests reached into a box to pull out a balloon to decorate and blow up. The colors they pulled out were:

red, white, red, green, white, blue, red, yellow, white, green, red, white, white, blue, green

Which frequency table correctly displays this data? Darken the correct letter choice.

COLORS OF BALLOONS

A

Color	Number of Balloons
blue	2
green	3
red	4
yellow	3
white	5

B

COLORS OF BALLOONS

Color	Number of Balloons
blue	2
green	3
red	4
yellow	1
white	6

COLORS OF BALLOONS

C

Color	Number of Balloons
blue	2
green	5
red	4
yellow	1
white	5

D

COLORS OF BALLOONS

Color	Number of Balloons
blue	2
green	3
red	4
yellow	1
white	5

✓ 5.DS.2

Look at this set of numbers. **12, 23, 16, 14, 12, 10, 25**

What is the median of the set of numbers?
Darken the correct letter choice.

A 16

B 15

C 12

D 14

✓ 5.DS.2

Natasha plays on the 5th grade basketball team at Hammond Elementary School. The chart shows how many points Natasha has scored so far this season.

What are Natasha's mean points scored over the first 5 games?
Darken the correct letter choice.

Latasha's Points Scored	
Game	Points
1	7 points
2	9 points
3	5 points
4	10 points
5	4 points

- A 6 points
- B 7 points
- C 8 points
- D 9 points

*✓ 5.DA.1

The information about animals in the Chicago Zoo is shown in the table.

Animals at Chicago Zoo	
Kind	Number
Lions	5
Elephants	10
Snakes	4
Monkeys	9
Rabbits	8

Which two statements best describes the information in the table?

- (A) The total number of animals is 36.
- (B) There are twice as many Lions as Elephants.
- (C) There are twice as many Elephants as Lions.
- (D) There are more Lions and Snakes than Elephants.
- (E) There are fewer Rabbits than Snakes.

✓ 5.DS.2

This table shows the amount of time Burt spent driving during each of the last 8 days.

What is the mode of this data set?
Darken the correct letter choice.

Number of Minutes Spent Driving	
Monday	62
Tuesday	53
Wednesday	37
Thursday	41
Friday	37
Saturday	45
Sunday	28
Monday	49

- Ⓐ 37 minutes
- Ⓑ 34 minutes
- Ⓒ 44 minutes
- Ⓓ 43 minutes

*✓ 5.DA.1

Kathy weighs tomatoes from her garden. The weight of each tomato, in pounds, is shown.

$$\frac{2}{8}, \frac{1}{8}, \frac{4}{8}, \frac{2}{8}, \frac{2}{8}, \frac{6}{8}, \frac{2}{8}, \frac{7}{8}, \frac{1}{8}, \frac{4}{8}$$

Which line plot correctly displays the weights of Kathy's tomatoes?
Darken the correct letter choice.

A

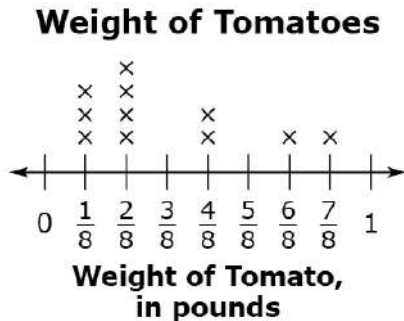

Key
x = 1 tomato

B

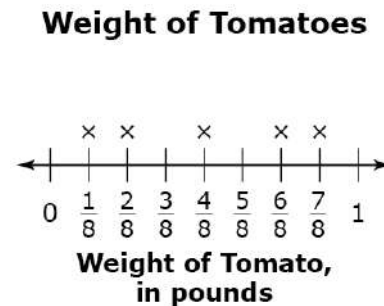

Key
x = 1 tomato

C

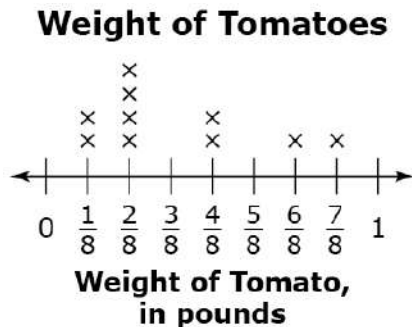

Key
x = 1 tomato

D

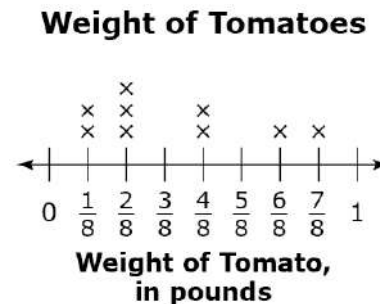

Key
x = 1 tomato

✓ 5.DS.2

The math scores for seven students in Mr. Wilson's 5th grade class on a chapter test are shown.

84 65 77 53 77 69 100

Find the **mean** of these seven math scores.
Write your answer on the answer blank.

Answer _____

***✓ 5.DA.1**

Cara asked each member of her class how many pets they owned. The results are shown.

2, 2, 0, 4, 2, 2, 4, 1, 0, 4, 1, 1, 2, 2, 3, 1, 2, 0, 3

Which frequency table correctly displays the results?
Darken the correct answer choice.

**Number of Pets Owned
by Students**

A

Number of Pets	Frequency
0	3
1	4
2	7
3	2
4	3

**Number of Pets Owned
by Students**

B

Number of Pets	Frequency
0	3
1	4
2	6
3	2
4	2

**Number of Pets Owned
by Students**

C

Number of Pets	Frequency
0	3
1	5
2	6
3	2
4	2

**Number of Pets Owned
by Students**

D

Number of Pets	Frequency
0	2
1	5
2	6
3	2
4	2

Look at this set of numbers.

12, 23, 16, 14, 12, 10, 25, 40

What is the median of the set of numbers?
Darken the correct letter choice.

A 16

B 15

C 12

D 14

*✓ 5.DA.1

The line plot shows the amount of snowfall recorded each day for one week. Study the line plot.

What is the total amount of snowfall, in inches, recorded for the week?
Darken the correct letter choice.

Snowfall in One Week

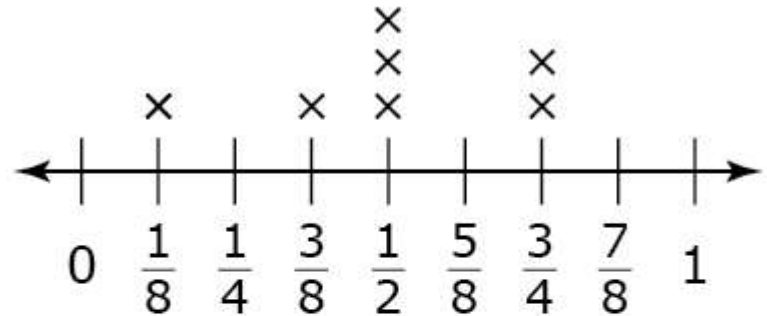

**Amount of Snowfall
(in inches)**

Key
x = 1 day

- (A) $1\frac{5}{8}$ inches
- (B) $1\frac{3}{4}$ inches
- (C) $2\frac{3}{4}$ inches
- (D) $3\frac{1}{2}$ inches

Geometry & Measurement

20-30%

Day 4A

***✓+ 5.M.1**

Convert among different-sized standard measurement units within a given measurement system, and use these conversions in solving multi-step real-world problems.

✓ 5.M.2

Find the area of a rectangle with fractional side lengths by modeling with unit squares of the appropriate unit fraction side lengths, and show that the area is the same as would be found by multiplying the side lengths. Multiply fractional side lengths to find areas of rectangles, and represent fraction products as rectangular areas.

***✓+ 5.M.3**

Develop and use formulas for the area of triangles, parallelograms and trapezoids. Solve real-world and other mathematical problems that involve perimeter and area of triangles, parallelograms and trapezoids, using appropriate units for measures.

✓ 5.M.4

Find the volume of a right rectangular prism with whole-number side lengths by packing it with unit cubes, and show that the volume is the same as would be found by multiplying the edge lengths or multiplying the height by the area of the base.

***✓+ 5.M.5**

Apply the formulas $V = l \times w \times h$ and $V = B \times h$ for right rectangular prisms to find volumes of right rectangular prisms with whole-number edge lengths to solve real-world problems and other mathematical problems.

***✓ 5.M.6**

Find volumes of solid figures composed of two non-overlapping right rectangular prisms by adding the volumes of the non-overlapping parts, applying this technique to solve real-world problems and other mathematical problems.

How many quarts are in 5 gallons?
Darken the correct letter choice.

(A) 5 quarts

(B) 10 quarts

(C) 15 quarts

(D) 20 quarts

What is the **area** of the triangle?
Darken the correct letter choice.

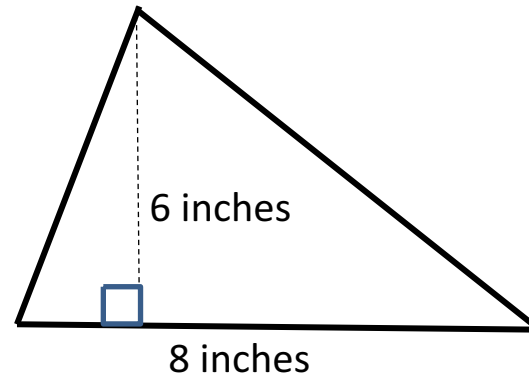

- (A) 14 inches
- (B) 20 inches
- (C) 24 square inches
- (D) 48 square inches

What is the **perimeter** of the shape?
Darken the correct letter choice.

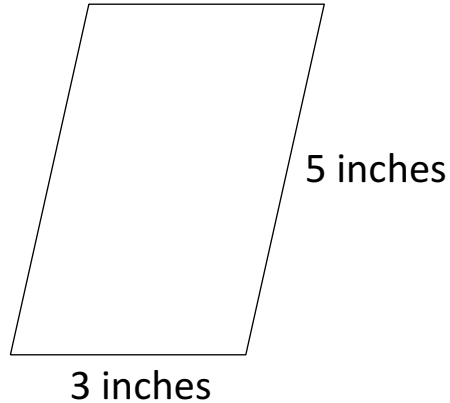

- (A) 8 inches
- (B) 16 inches
- (C) 15 square inches
- (D) 30 square inches

How many pints in 2 gallons?
Darken the correct letter choice.

A 4 pints

B 15 pints

C 8 pints

D 16 pints

Find the area of the shape.
Darken the correct letter choice.

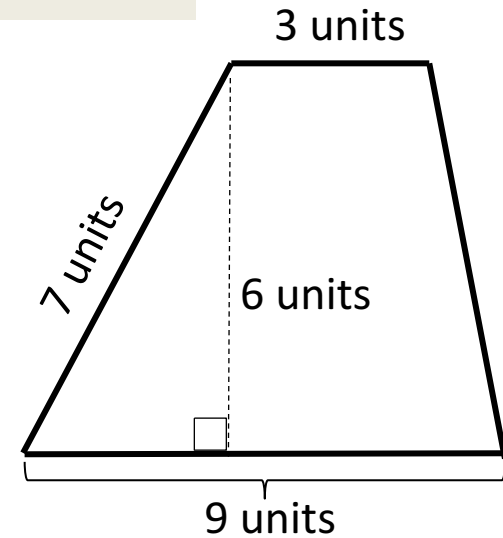

- (A) 36 square units
- (B) 25 square units
- (C) 54 square units
- (D) 72 square units

What number makes the equation true?
Darken the correct letter choice.

$$5 \text{ kilometers} = \square \text{ centimeters}$$

(A) 100,000 centimeters

(B) 10,000 centimeters

(C) 50,000 centimeters

(D) 500,000 centimeters

Which work is correct for finding the area of the triangle?
Darken the correct letter choice.

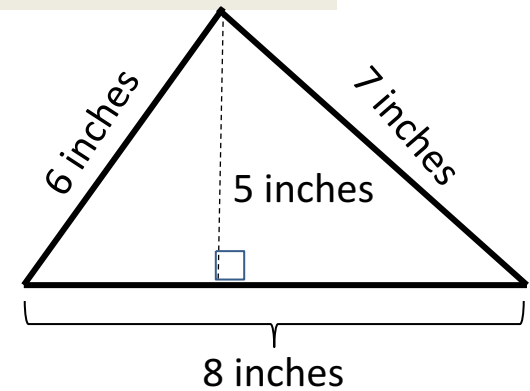

- (A) $5 + 8 = 13$ inches
- (B) $5 + 6 + 7 + 8 = 26$ inches
- (C) $8 \times 5 = 40$ square inches
- (D) $\frac{1}{2} (8 \times 5) = 20$ square inches

Which work is correct for finding the perimeter of the triangle?
Darken the correct letter choice.

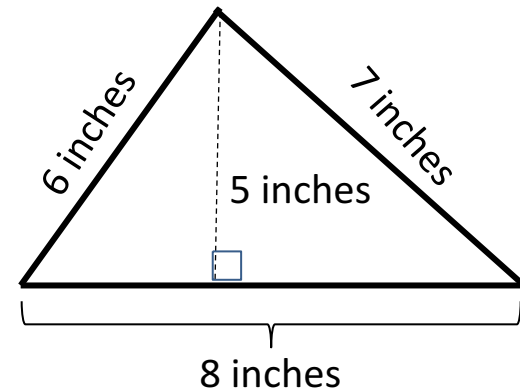

- (A) $5 + 8 = 13$ inches
- (B) $6 + 7 + 8 = 21$ inches
- (C) $8 \times 5 = 40$ square inches
- (D) $\frac{1}{2}(8 \times 5) = 20$ square inches

Look at this diagram of a city swimming pool.

What is the area of the swimming pool?
Darken the correct letter choice.

City Swimming Pool

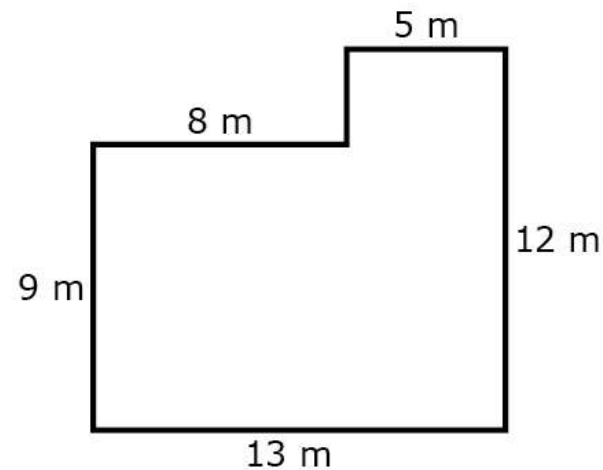

- A 157 square meters
- B 156 square meters
- C 47 square meters
- D 132 square meters

What is the area of the shape?
Darken the correct letter choice.

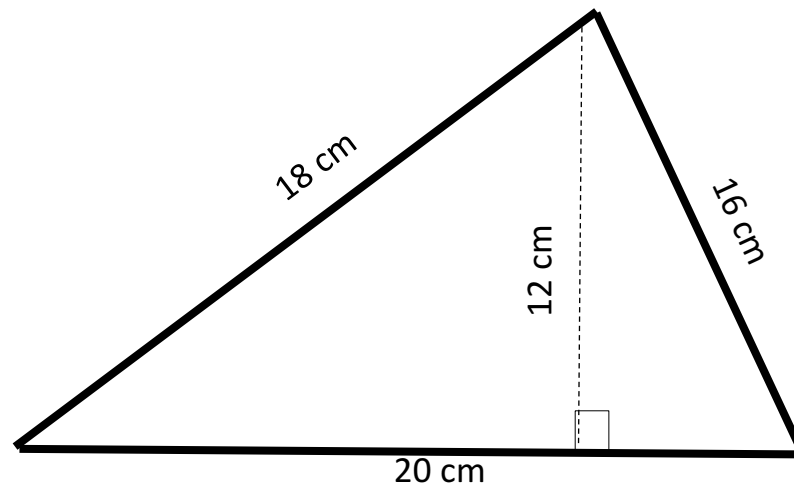

- (A) 68 square centimeters
- (B) 120 square centimeters
- (C) 54 square centimeters
- (D) 240 square centimeters

What is the area of the shape?
Darken the correct letter choice.

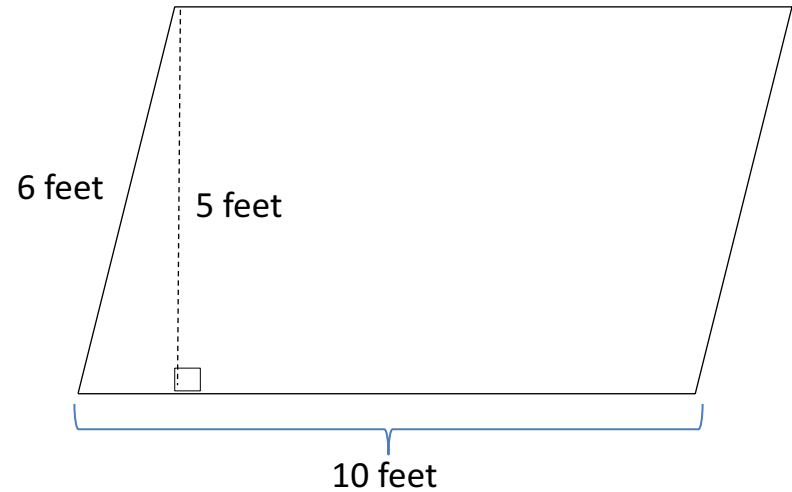

- (A) 21 square feet
- (B) 32 square feet
- (C) 60 square feet
- (D) 50 square feet

Playground at Jefferson School has the shape shown below.

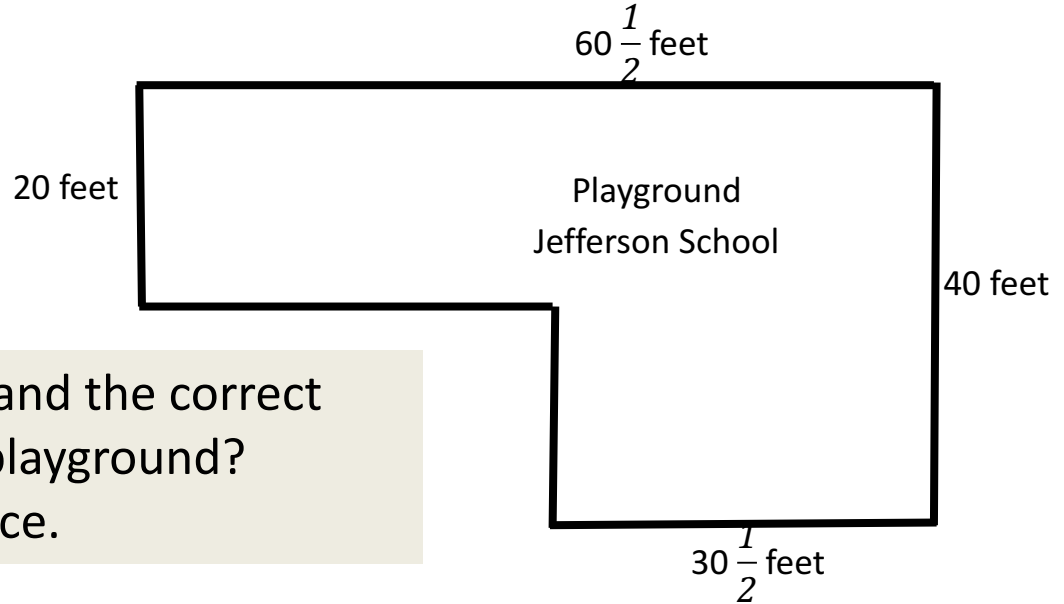

Which shows the correct work and the correct answer to find the area of the playground?
Darken the correct answer choice.

A Area = $30\frac{1}{2} \times 40 + 20 \times 30$
Area = $1220 + 600$
Area = 1820 square feet

B Area = $30\frac{1}{2} + 40 + 60\frac{1}{2} + 20$
Area = 151 square feet

C Area = $30\frac{1}{2} + 40 + 60\frac{1}{2} + 20 + 30 + 20$
Area = 201 square feet

D Area = $30\frac{1}{2} \times 40 + 20 \times 20$
Area = $1220 + 400$
Area = 1620 square feet

Which **two** statements are true?
Darken the correct letter choice.

- (A) 2 kilograms = 2,000 grams
- (B) 2 meters = 20 centimeters
- (C) 3 liters = 300 milliliters
- (D) 4 mile = 21,120 feet
- (E) 3 pounds = 30 ounces

The window is in the shape of trapezoid as shown below.
What is the area of the window?
Darken the correct letter choice.

- A 24 square feet
- B 36 square feet
- C 28 square feet
- D 18 square feet

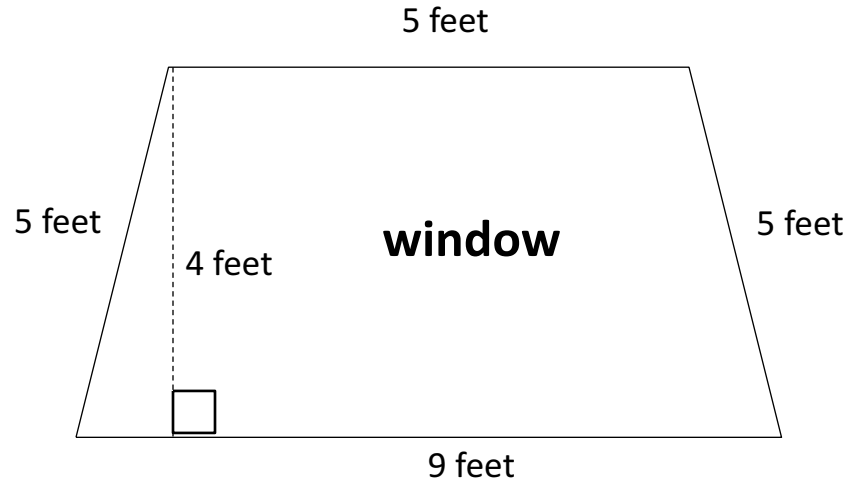

Study the figure made up of two rectangular prisms.

What is the volume, in cubic yards, of the figure?
Darken the correct letter choice.

- (A) 20 cubic yards
- (B) 45 cubic yards
- (C) 63 cubic yards
- (D) 99 cubic yards

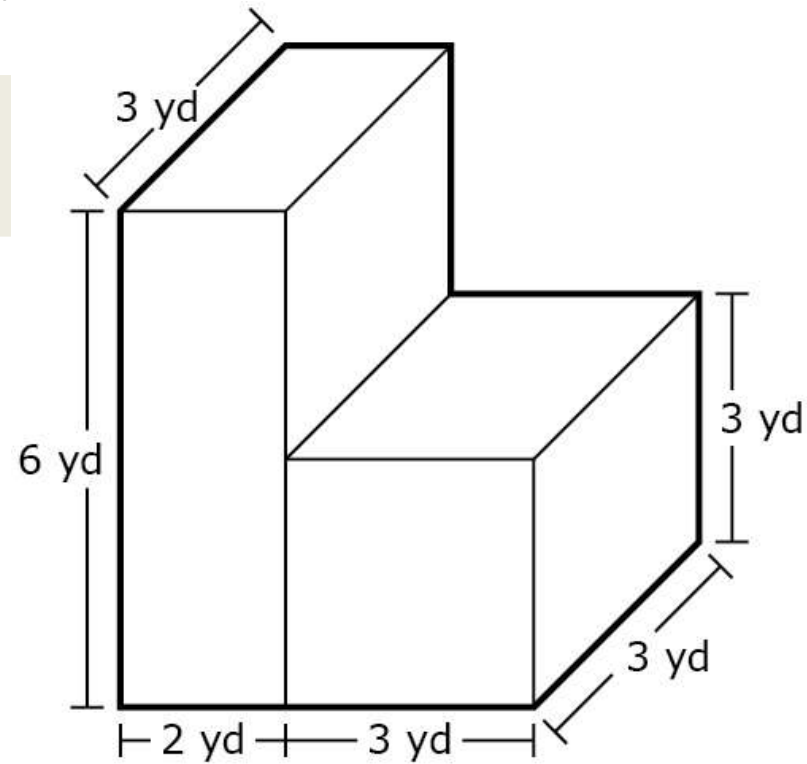

Find the two measurements that are equal to 2 meters.
Darken the correct letter choices.

(A) 200 centimeters

(B) 200 kilometers

(C) 20 centimeters

(D) 2,000 millimeters

(E) 2,000 centimeters

(F) 20 kilometers

A student wants to find the volume of the cereal box shown. The cereal box is in the shape of a rectangular prism.

What is the volume, in cubic inches, of the cereal box?
Darken the correct letter choice.

- (A) 25 cubic inches
- (B) 384 cubic inches
- (C) 432 cubic inches
- (D) 50 cubic inches

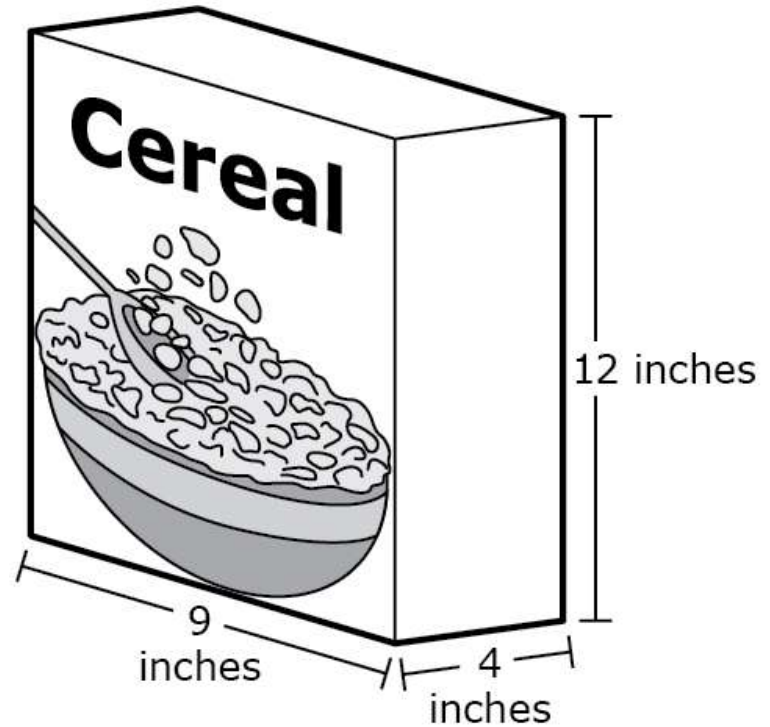

What is the volume, in cubic inches, of the figure?
Darken the correct letter choice.

- (A) 20 cubic inches
- (B) 28 cubic inches
- (C) 30 cubic inches
- (D) 40 cubic inches

Study the figure.

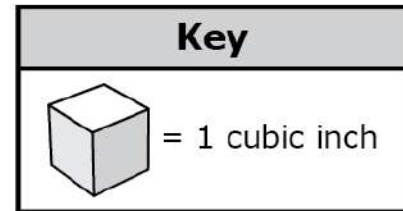
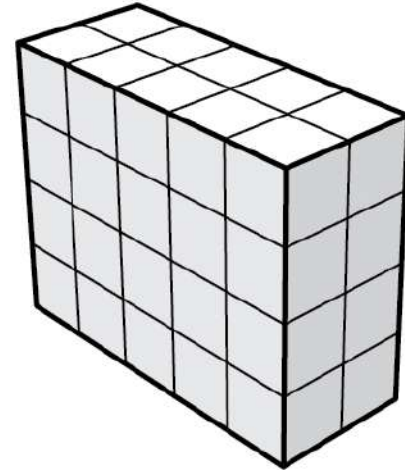

Use the rectangle to solve the problem.

Darken the **two** values equivalent to the area, in square inches, of the rectangle.

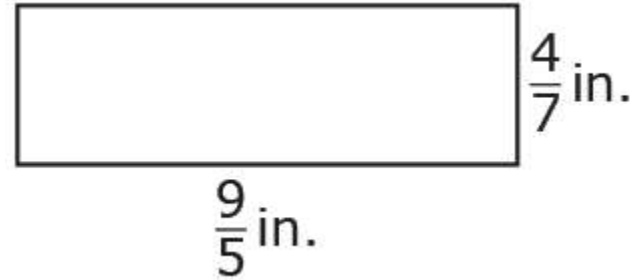

- (A) $3\frac{3}{20}$ square inches
- (B) $\frac{36}{35}$ square inches
- (C) $\frac{63}{20}$ square inches
- (D) $2\frac{13}{35}$ square inches
- (E) $\frac{83}{35}$ square inches
- (F) $1\frac{1}{35}$ square inches

Choose the two measurements that are equal to 3 yards.
Darken the correct letter choices.

A 1 foot

B 3 feet

C 3 inches

D 9 feet

E 38 inches

F 108 inches

Day 4B

A small rectangular lawn is covered in squares of grass.

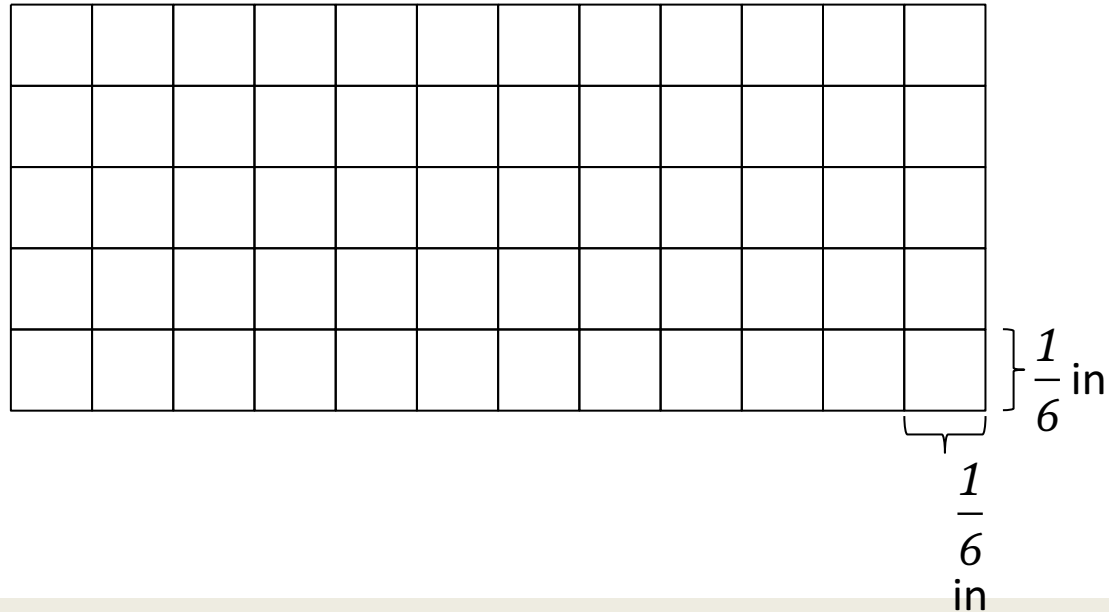

What is the area, in square yards (sq yd), of the lawn?
Darken the correct letter choice.

- (A) $1\frac{2}{3}$ sq. yds. (B) $5\frac{2}{3}$ sq. yds. (C) 34 sq. yds. (D) 60 sq. yds.

✓ 5.M.4

The rectangular prism is shown .

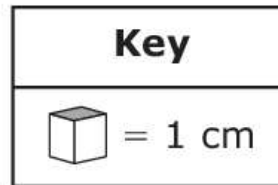
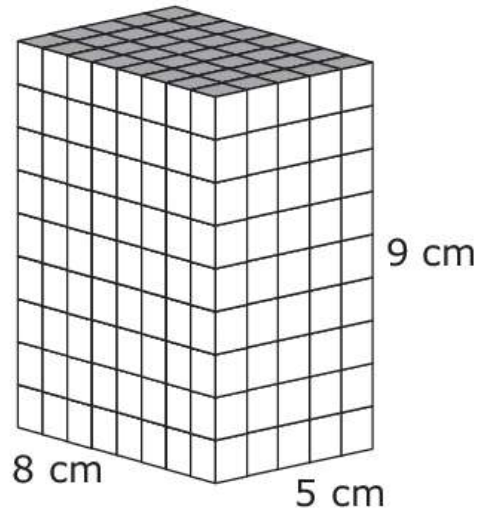

Write the volume, in cubic centimeters, of the rectangular prism.
Place your answer on the answer blank.

Answer cubic centimeters

A toy box is in the shape of a right rectangular prism.
What is the volume of the toy box?
Darken the correct letter choice.

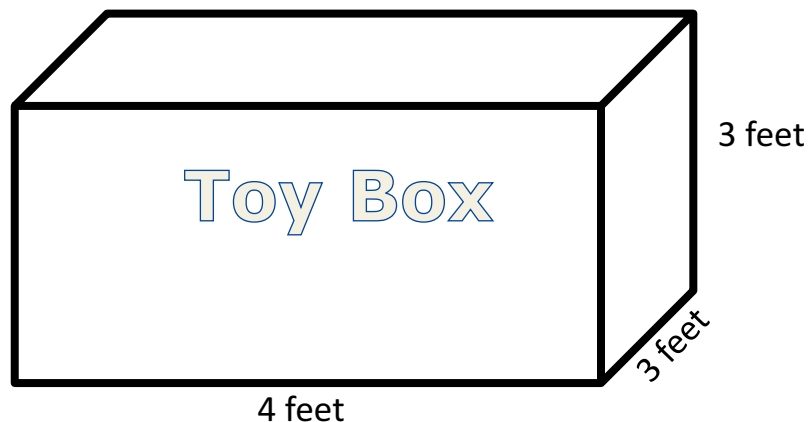

- A 13 cubic feet
- B 25 cubic feet
- C 34 cubic feet
- D 36 cubic feet

✓ 5.M.2

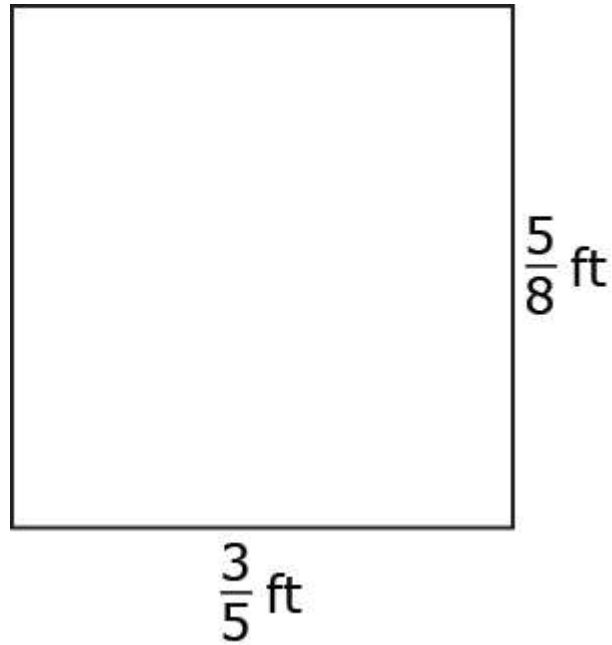

Write the area of the rectangle?
Place your answer on the answer blank.

Answer square feet

*✓+ 5.M.3

ISTEP

Reference

Sheet

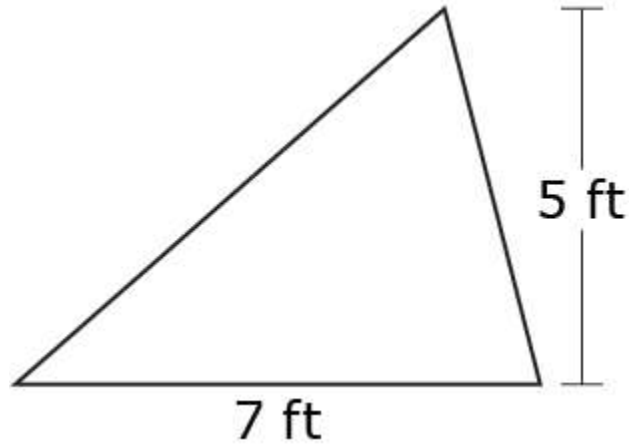

Write the area of the triangle?
Place your answer on the answer blank.

Answer square feet

Jared wants to make a jewelry box in the shape of a rectangular prism with a volume of 162 cubic inches.

If the height of the box will be 3 inches, which of these could be the dimensions of the base? Darken the correct letter choice.

- Ⓐ 3 inches by 3 inches
- Ⓑ 9 inches by 6 inches
- Ⓒ 11 inches by 15 inches
- Ⓓ 30 inches by 24 inches

What is the area, in square inches, of the trapezoid $PQRS$?
Darken the correct letter choice.

- (A) 27 cubic inches
- (B) 30 cubic inches
- (C) 33 cubic inches
- (D) 39 cubic inches

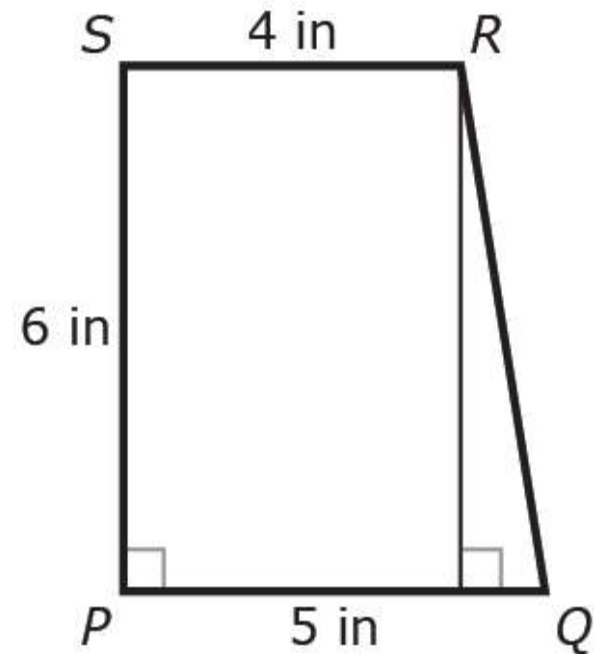

A birthday present is in the shape of a box as shown.
What is the volume of the birthday present?
Darken the correct letter choice.

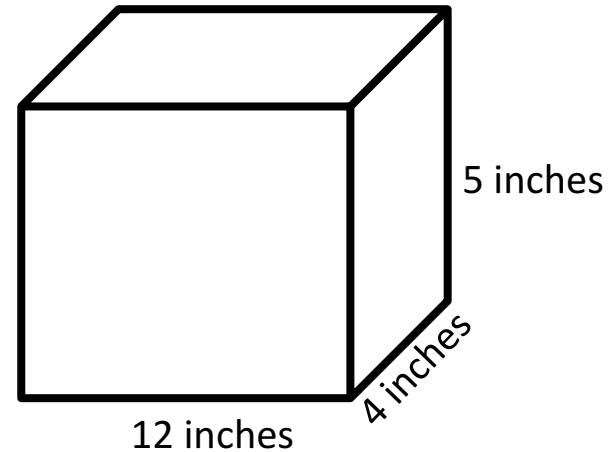

- A 240 cubic units
- B 21 cubic units
- C 144 cubic units
- D 20 cubic units

✓ 5.M.4

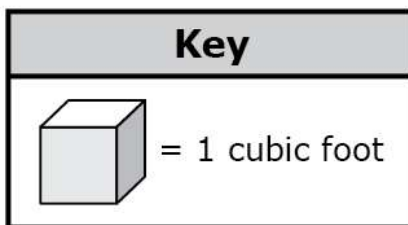
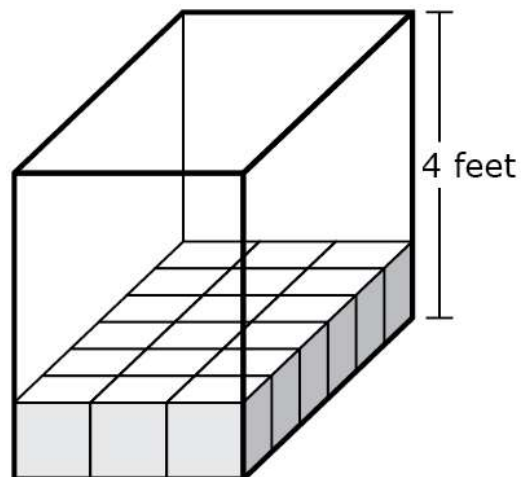

What is the volume, in cubic feet, of the figure?
Place your answer on the answer blank.

Answer cubic foot

What is the volume, in cubic yards, of the stairs?
Darken the correct letter choice.

- (A) $9\frac{1}{2}$ cubic feet
- (B) 10 cubic feet
- (C) 9 cubic feet
- (D) $10\frac{1}{2}$ cubic feet

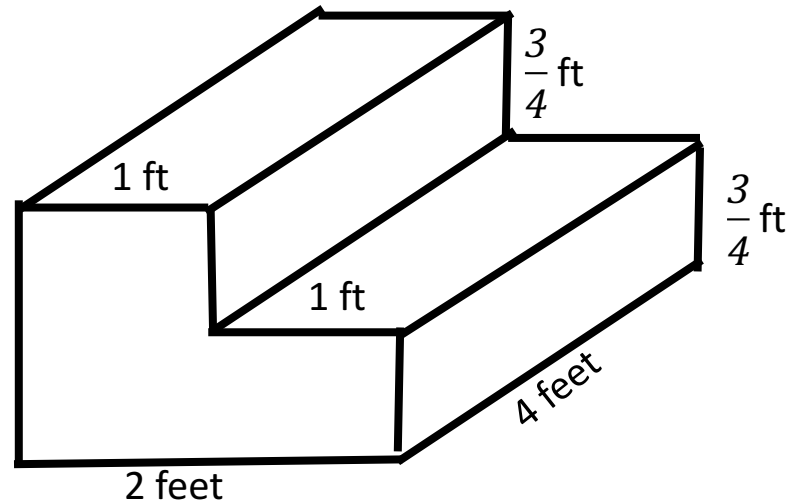

Legos are stuck together to form a shape. Each Lego cube is 1 cubic unit. What is the volume of the entire shape? Darken the correct letter choice.

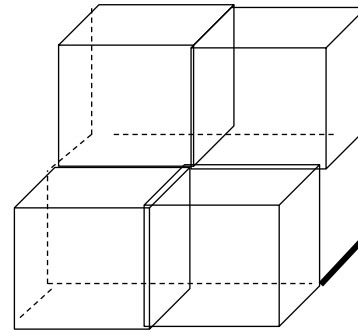

- A 8 cubic units
- B 6 cubic units
- C 10 cubic units
- D 12 cubic units

✓ **5.G.1**

Identify, describe, and draw triangles (right, acute, obtuse) and circles using appropriate tools (e.g., ruler or straightedge, compass and technology). Understand the relationship between radius and diameter.

*✓ **5.G.2**

Identify and classify polygons including quadrilaterals, pentagons, hexagons, and triangles (equilateral, isosceles, scalene, right, acute and obtuse) based on angle measures and sides. Classify polygons in a hierarchy based on properties.

*✓5.G.2

Which two shapes are a quadrilateral and a hexagon?

Drag and drop two shapes from the Selection Menu to the correct answer blanks. Not all of the shapes will be used.

Quadrilateral _____

Hexagon _____

Selection Menu

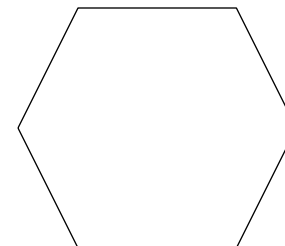
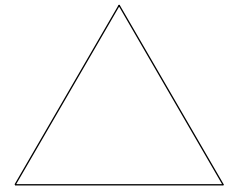
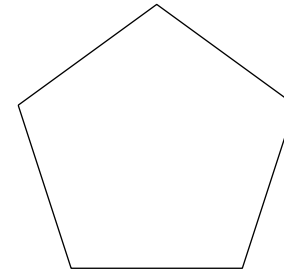
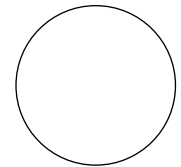

✓5.G.1

Which two shapes show a radius of a circle?

Drag and drop two shapes from the Selection Menu to the correct answer blanks. Not all of the shapes will be used.

Selection Menu

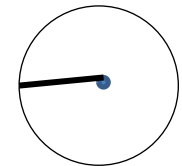
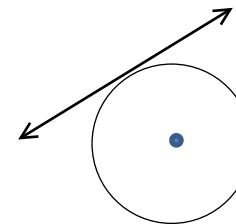
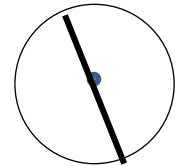
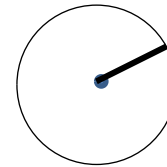
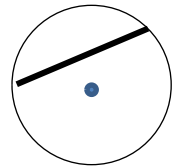
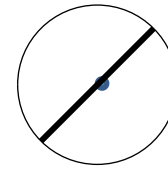

What is the name of this shape?
Darken the correct letter choice.

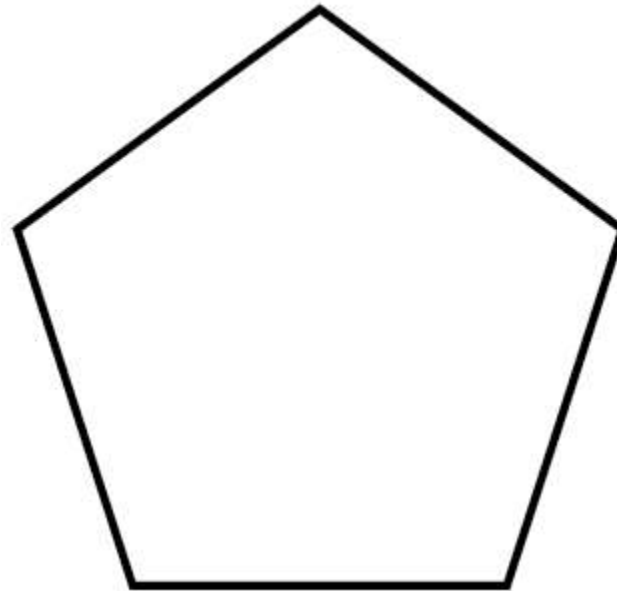

- A quadrilateral
- B rhombus
- C pentagon
- D hexagon

✓ 5.G.1

Which of these shapes is an acute triangle?
Darken the correct answer choice.

A

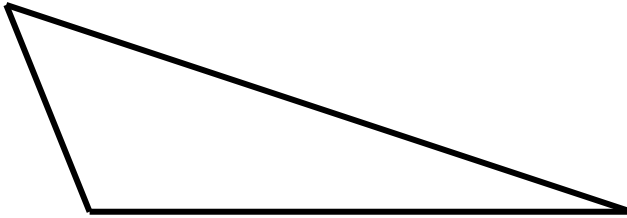

C

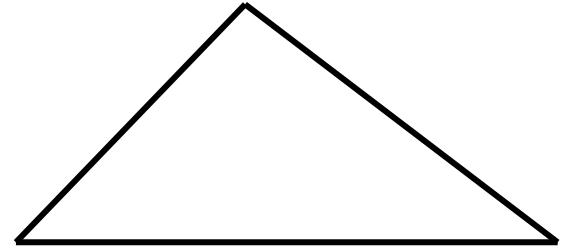

B

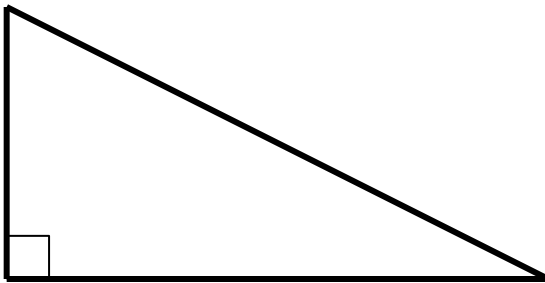

D

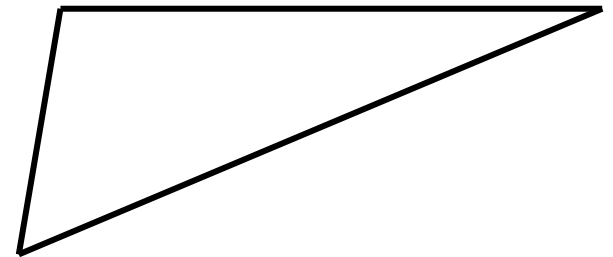

***✓5.G.2**

Which shapes are examples of scalene triangles and isosceles triangle?

Drag and drop from the Selection Menu to the correct answer blanks.

Selection Menu

isosceles _____

scalene _____

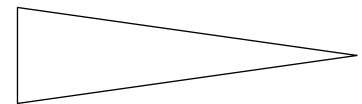
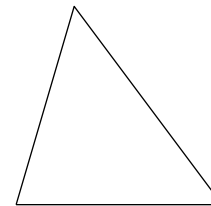
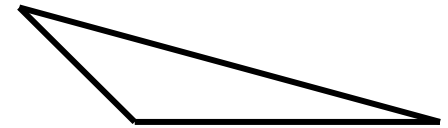
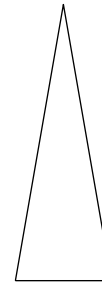

✓5.G.1

Which two shapes show a diameter of a circle?

Drag and drop two shapes from the Selection Menu to the correct answer blanks. Not all of the shapes will be used.

Selection Menu

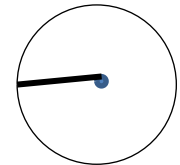
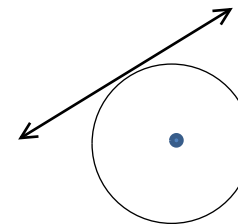
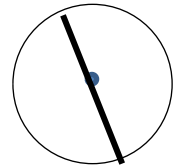
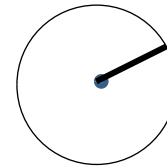
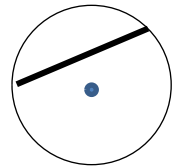
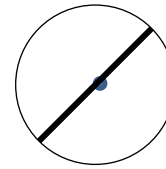

*✓5.G.2

Which two shapes are a quadrilateral and a hexagon?

Drag and drop two shapes from the Selection Menu to the correct answer blanks. Not all of the shapes will be used.

Quadrilateral _____

Hexagon _____

Selection Menu

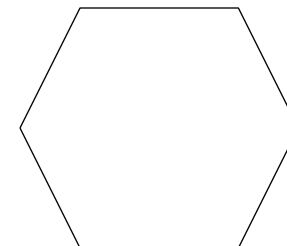
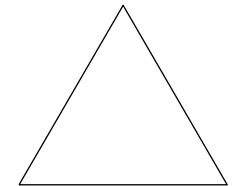
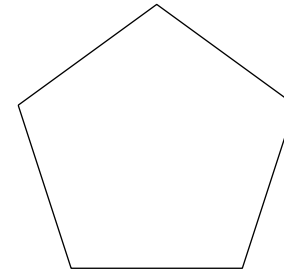
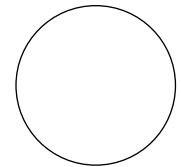
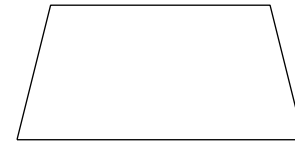

Which of these statements about a rectangle is **always** true?
Darken the correct letter choice.

- A A rectangle is a rhombus and a square.
- B A rectangle is a parallelogram and a square.
- C A rectangle is a quadrilateral and a rhombus.
- D A rectangle is a quadrilateral and a parallelogram.

Look at the fence.

What is the shape of the highlighted board?

Darken the correct letter choice.

A

octagon

B

pentagon

C

rhombus.

D

trapezoid

