

# Words with Long Vowels

Read each clue. Write two rhyming words from the Word Bank to answer the clue.

base	rage	globe	joke
home	shade	skate	lime
broke	chase	plate	tone
probe	chrome	slime	phone
cage	shake	snake	trade

- If you chase your friend around the bases on a field, you play a game of \_\_\_\_\_.
- If a joke wasn't funny, the \_\_\_\_\_.
- If a lime rots, you will have \_\_\_\_\_.
- A snake that is cold does a dance called a \_\_\_\_\_.
- An angry bird in a cage may get \_\_\_\_\_.
- If you put paper plates under your feet, you can go for a \_\_\_\_\_.
- If you look up places on a globe, you play a game called \_\_\_\_\_.
- If you switch shiny spots, you do a \_\_\_\_\_.
- When you pick up a telephone, you hear a sound called a \_\_\_\_\_.
- A shiny, silver house is a \_\_\_\_\_.

# Conclusions

Read the passage. Then complete the Inference Map.

Sam and Christy sat on a bench in the back yard. They stared unapologetically at the garden tools and gloves their Mom had set out for them. Their sad faces suggested that this was not how they liked to spend Saturday morning. They started trying to think of an easier way to earn money.

"We could sell lemonade," said Christy.

"Nah," said Sam. "Last time we did that we only made four dollars. It would take forever to make enough money that way."

"How about walking dogs or putting on a talent show?" said Christy.

"We'd never be able to raise forty dollars walking dogs. And what talent do we have that people would pay to see?" asked Sam.

Christy sighed. "You're right. No one would pay to see us."

"We might as well face it," said Sam. "We're stuck weeding Mom's gardens for the next three Saturday mornings."

Christy groaned. "Mom sure knows how to make us remember the rules. I just hate weeding." She looked at the broken window next to the back door. "I'm never going to play baseball in the back yard again!"

Detail	Detail	Detail
Conclusion		

# The Trial of Cardigan Jones

Phonics  
Long Vowels: e, i, o, u

# Spelling Word Sort

Write each Basic Word under the correct heading.

Long a	Long i
1. _____	4. _____
2. _____	5. _____
3. _____	6. _____
	7. _____
	8. _____
Long o	Long u
9. _____	12. _____
10. _____	13. _____
11. _____	14. _____

**Review** What long vowel sound does the Review Word *these* have? \_\_\_\_\_

\_\_\_\_\_ What long vowel sound does the Review Word *those* have? \_\_\_\_\_

Review Word *those* have? \_\_\_\_\_

**Challenge** In which column do the two Challenge Words belong? \_\_\_\_\_

\_\_\_\_\_

## Spelling Words

### Basic

- spoke
- mile
- save
- excuse
- cone
- invite
- cube
- price
- erase
- ripe
- broke
- flame
- life
- rule

### Review

- these
- those

### Challenge

- surprise
- decide

# Words with the VCe Pattern

Read each word. Draw a line to match the word to its meaning.

### Column 1

- awake
- costume
- divide
- escape
- exercise
- microphone
- mistake
- refuse
- sidewalk
- unite

### Column 2

- clothes worn to make somebody look like somebody or something else
- to free oneself or get away from
- to bring things together
- an error
- not asleep
- a paved path where people can walk alongside a street
- to separate
- to say no
- to work out or do a physical activity
- a device to make someone's voice louder

Write each word from Column 1 in the correct place in the chart below. Look at the part of the word with the VCe pattern.

Long a	Long i	Long o	Long u

Name \_\_\_\_\_ Date \_\_\_\_\_

## Statements, Questions, Commands, and Exclamations

Write *statement* if the sentence tells something. Write *question* if the sentence asks something.

1. I like basketball. \_\_\_\_\_
2. I would not want to climb a mountain. \_\_\_\_\_
3. Where do you row your boat? \_\_\_\_\_
4. Do you like to play tennis? \_\_\_\_\_
5. What do you know about judo? \_\_\_\_\_

Write *command* if the sentence tells someone to do something.

Write *exclamation* if the sentence shows strong feeling.

6. Pick up the tennis racket. \_\_\_\_\_
7. Tennis is a great sport! \_\_\_\_\_
8. Please join me in a game. \_\_\_\_\_
9. Ask him to play tennis with us. \_\_\_\_\_
10. I will not ask him! \_\_\_\_\_

Name \_\_\_\_\_ Date \_\_\_\_\_

## Compound Words

Read the compound words. On the first line, write the two shorter words that make up the compound word. On the second line, write a sentence using the compound word.

1. lunchbox  
 \_\_\_\_\_  
 \_\_\_\_\_
2. notebook  
 \_\_\_\_\_  
 \_\_\_\_\_
3. playground  
 \_\_\_\_\_  
 \_\_\_\_\_
4. classroom  
 \_\_\_\_\_  
 \_\_\_\_\_
5. homework  
 \_\_\_\_\_  
 \_\_\_\_\_
6. troublemaker  
 \_\_\_\_\_  
 \_\_\_\_\_

# Proofreading for Spelling

Read the following invitation. Find and circle the misspelled words.

No you sometimes wish there was no such thing as a rule? Let's think about how let would be different without rules. You may surpris yourself and be thankful for rules!

Let's say you have an ice cream con. I see it and decid I want it. I take your ice cream. I do not say excuse me. I eat it all, even though you paid the prize for it.

Thos actions would make you mad, wouldn't they? But since there are no rules, the only thing I brok was your pride. I did not break a rule.

Rules say us from situations like these. Rules help us all get along.

Write the misspelled words correctly on the lines below.

1. \_\_\_\_\_ 6. \_\_\_\_\_
2. \_\_\_\_\_ 7. \_\_\_\_\_
3. \_\_\_\_\_ 8. \_\_\_\_\_
4. \_\_\_\_\_ 9. \_\_\_\_\_
5. \_\_\_\_\_ 10. \_\_\_\_\_

The Trial of  
Carrigan Jones  
Spelling  
Vowel Spellings

## Spelling Words

- |                  |
|------------------|
| <b>Basic</b>     |
| 1. spoke         |
| 2. mile          |
| 3. save          |
| 4. excuse        |
| 5. cone          |
| 6. invite        |
| 7. cube          |
| 8. price         |
| 9. erase         |
| 10. ripe         |
| 11. broke        |
| 12. flame        |
| 13. life         |
| 14. rule         |
| <b>Review</b>    |
| these            |
| those            |
| <b>Challenge</b> |
| surprise         |
| decide           |

# Common Vowel Pairs

## ai, ay, ee, ea

Write the word from the Word Bank that best completes each sentence.

always	ease	stain	steam
bat	greedy	players	sweeten
breeze	holiday	queen	trail
chain	layers	seasons	

1. Of all the \_\_\_\_\_, fall is my favorite.
2. When you boil water, the \_\_\_\_\_ you see is the water vapor.
3. There was no school yesterday because it was a \_\_\_\_\_.
4. The door is secured with a lock and strong \_\_\_\_\_.
5. I knew it was the \_\_\_\_\_ because of her crown.
6. The hikers walked along the marked \_\_\_\_\_.
7. The artist paints at his \_\_\_\_\_.
8. To be safe, I \_\_\_\_\_ look both ways at a stop sign.
9. I will use honey to \_\_\_\_\_ the iced tea.
10. The cake has three different \_\_\_\_\_.
11. The spilled juice left a \_\_\_\_\_ on the carpet.
12. On a hot day, a \_\_\_\_\_ is welcome.
13. Remember to take the \_\_\_\_\_ with you when you go fishing.
14. Four \_\_\_\_\_ can play the game at the same time.
15. If you do not share, people may think you are \_\_\_\_\_.

# Understanding Characters

**Destiny's Gift**  
Introduce Comprehension: Understanding Characters

Read the selection below.

After dinner, Mom showed Carlos something that had come in the mail. It was pictures of animals at a shelter. The shelter was asking for money to take care of the animals. "I want to help those animals," said Carlos. "I'm going to raise money for the shelter." Just then, Carlos's older brother, Philip, came into the kitchen. Carlos told Philip about his plan to help. "I want to help, too," Philip said.

The very next day, Carlos started. Everywhere he went, he showed people the pictures and collected money. After a month, Carlos had raised over \$500. Mom drove Carlos and Philip to the shelter. Carlos gave the manager the money. "I helped, too," Philip said. Mom took a picture of Carlos, Philip, and the manager. She put it in the newspaper.

Later, Mom asked Carlos why he let Philip take some of the credit for raising the money. Carlos explained, "I just want to help the animals." Mom smiled from ear to ear and gave Carlos a huge hug. "You did help them," she said.

Complete the Column Chart to show your understanding of Carlos and Philip.

Details About the Character	My Experience	What I Think

# Spelling Word Sort

**Destiny's Gift**  
Spelling:  
More Long *a* and Long *e* Spellings

Write each Basic Word under the correct heading.

Spelling Words		
Long <i>a</i> Spelled <i>ay</i>	Long <i>a</i> Spelled <i>ai</i>	
Long <i>e</i> Spelled <i>ee</i>	Long <i>e</i> Spelled <i>ea</i>	

**Basic**  
 1. lay  
 2. real  
 3. trail  
 4. sweet  
 5. today  
 6. dream  
 7. seem  
 8. tea  
 9. treat  
 10. afraid  
 11. leave  
 12. bait  
 13. screen  
 14. speed

**Review**  
 paint  
 please

**Challenge**  
 yesterday  
 explain

**Review** Add the Review Words to your Word Sort.

**Challenge** Add the Challenge Words to your Word Sort.

## Correct Run-ons

Destiny's Gift  
Grammar  
Sequence Diagrams and Run-ons

Two or more sentences that run together are called run-on sentences. Use end marks and capital letters correctly to keep sentences from running together.

*Do you want to find out more about moose go to the library.*

*Do you want to find out more about moose? Go to the library.*

Do not use a comma to separate two sentences.

*I don't have any moose books, I'll go to the library.*

*I don't have any moose books. I'll go to the library.*

**Thinking Question**  
*What correct end marks and capital letters will keep two sentences from running together?*

Correct each run-on sentence. Write it as two sentences.

1. Moose is the American name for the largest deer it is called *elk* in Europe.

2. The name comes from *mos* the word is from a Maine Indian language.

3. Moose live in forests, they are comfortable in the cold.

## Cumulative Review

Destiny's Gift  
Phonics  
Cumulative Review

Read the grocery list. Write each item in the chart below.

Grocery List		Long e	Long i spelled V <i>Ce</i>	Long o spelled V <i>Ce</i>	Long u spelled V <i>Ce</i>
artichokes	grapes				
beans	lemonade				
beef	limes				
cheese	grains				
coffee	oatmeal				
	crayfish				
V <i>Ce</i>		V <i>Ce</i>			
ai		ee			
ay		ea			

Write a recipe on another sheet of paper. Use at least three words on the list. You can use other ingredients, too.

# Antonyms

Destiny's Gift  
Vocabulary Strategies  
Antonyms

lower	all	left
catch	lake	last

Read each word below. Write the antonym from the box above. Then write a sentence using both words.

- nothing \_\_\_\_\_
- first \_\_\_\_\_
- raise \_\_\_\_\_
- right \_\_\_\_\_
- throw \_\_\_\_\_
- give \_\_\_\_\_

# Proofreading for Spelling

Destiny's Gift  
Spelling  
Miss Long and Long's Spellings

Read each sign. Find and circle the misspelled words.

- Pieces do not feed the bears.
- Spead Limit  
55  
Miles per Hour
- Stay on the trail.
- Sweetee fee \$1.00  
Peanuts \$ .50
- The zoo will close today at 4 PM.
- Lieve your shops outside.
- Stay out!  
Wef paynt.
- Do not be afraid to try new things.

Write the misspelled words correctly on the lines below.

- \_\_\_\_\_
- \_\_\_\_\_
- \_\_\_\_\_
- \_\_\_\_\_
- \_\_\_\_\_
- \_\_\_\_\_
- \_\_\_\_\_
- \_\_\_\_\_

## Spelling Words

### Basic

- lay
- real
- trait
- sweet
- today
- dream
- seem
- lea
- treat
- afraid
- leave
- bait
- screen
- speed

### Review

- paint
- please

### Challenge

- yesterday
- explain

# Proofreading for Spelling

Destiny's Gift  
Spelling  
Miss Long and Long's Spellings

Read each sign. Find and circle the misspelled words.

- Pieces do not feed the bears.
- Spead Limit  
55  
Miles per Hour
- Stay on the trail.
- Sweetee fee \$1.00  
Peanuts \$ .50
- The zoo will close today at 4 PM.
- Lieve your shops outside.
- Stay out!  
Wef paynt.
- Do not be afraid to try new things.

Write the misspelled words correctly on the lines below.

- \_\_\_\_\_
- \_\_\_\_\_
- \_\_\_\_\_
- \_\_\_\_\_
- \_\_\_\_\_
- \_\_\_\_\_
- \_\_\_\_\_
- \_\_\_\_\_

# Long o Spelled oa, ow

Pop's Bridge  
Phonics:  
Long o Spelled oa, ow

Each word in the Word Bank is in the puzzle. Find and circle each word in the puzzle.

arrow	floating	undertow
below	goat	upland
blown	slow	
coach	throwing	

p o p l o a d n u p  
o b l o p i r l n b  
b l o w n e u l d e  
e o t h r l t h o e c  
l c o a c h s a r o  
o p w r a r l t t h  
w b l l b r o i o b  
n c a r r o w n w o  
l o p e n i n g b a  
y t h r o w i n g c

On a separate sheet of paper, use each word in the Word Bank in a sentence. Read your sentences aloud.

# Compare and Contrast

Pop's Bridge  
Introduction Comprehension:  
Compare and Contrast

Read the selection below.

The boy selling newspapers yelled the headline, "Bridge Complete!" His stack of papers was disappearing quickly. Even Mom bought one. "What's the big deal?" Samuel asked her.

"The Golden Gate Bridge is finished!" she answered him. Samuel was curious but still not impressed. "It's just a bridge," he thought to himself.

That afternoon, Dad announced, "There's a parade at the bridge tomorrow. I want us to be there to celebrate!" The next day, Samuel left to go to the parade. He still didn't understand why everyone was making such a big deal out of the new bridge. He wanted to find out.

At the bridge, Samuel and his family joined the crowd and waited. Then, a foghorn sounded and everyone began walking across the bridge. Samuel looked up at the bridge. He looked down at the swirling tide. This bridge was a huge project. Its completion was a statement. It said America was strong, just like this bridge. Samuel was proud to be crossing the bridge with his family. Now Samuel wanted to know more about the bridge.

Complete the Venn diagram to show how Samuel changes and how he stays the same.

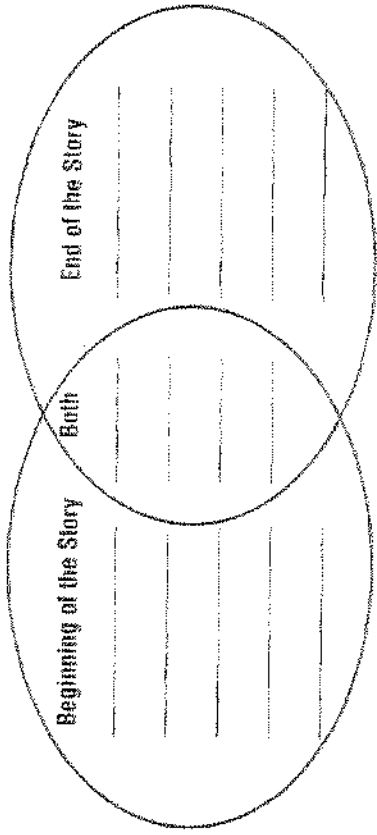



# Spelling Word Sort

Write each Basic Word under the correct heading.

Long o Spelled o	Long o Spelled ow
_____	_____
_____	_____
_____	_____
_____	_____
Long o Spelled oa	_____
_____	_____
_____	_____

**Review** Add the Review Words to your Word Sort.

**Challenge** Add the Challenge Words to your Word Sort.

## Spelling Words

### Basic

- load
- open
- told
- yellow
- soak
- shadow
- foam
- follow
- glow
- sold
- window
- coach
- almost
- throat

### Review

cold  
most

### Challenge

tomorrow  
sailboats

# Cumulative Review

Read each clue. Unscramble the letters and write the word that answers the clue. Read the words you made.

- This is a food. Many people eat it in the morning.      **intveatla**
- You might do this if you do not want to do something.      **unkoptnat**
- Cars drive fast on these kinds of roads. They have two or more lanes.      **whqyshta**
- This is a way to heat bread.      **tasot**
- This can take you across the sea, when it's windy.      **aitnalxus**
- This number is the answer to these math problems:  $5 \times 3$  and  $5 + 5 + 5$ .      **efnielt**
- There are four of these. They are winter, spring, summer, and fall.      **exsasis**
- This is the color of a lemon.      **lelwyo**
- This describes something that never moves very quickly.      **wols**
- This can help you find your way when you are driving.      **putraaom**

# Common and Proper Nouns

Pop's Bridge  
Grammar  
Common and Proper Nouns

1-5. Write the two nouns in each sentence.

1. The boys watched the hotel being taken down. \_\_\_\_\_
2. A large ball knocked down the old walls. \_\_\_\_\_
3. A new building would go up in that space. \_\_\_\_\_
4. Somr, a huge hole was in the ground. \_\_\_\_\_
5. In a few years, a skyscraper would be there. \_\_\_\_\_

6-10. Write *common* or *proper* for each underlined noun.

6. We learned about the Middle Ages in school. \_\_\_\_\_
7. My aunt came all the way from Canada. \_\_\_\_\_
8. The crowd rode horses. \_\_\_\_\_
9. It was an exciting day. \_\_\_\_\_
10. My friends live near the Brooklyn Bridge. \_\_\_\_\_

# Word Endings

## -s, -es, -ed, -ing

Pop's Bridge  
Vocabulary Strategies  
Base Words and Endings

disappear	remind	call
push	support	form
balance	construct	

For each item, choose a base word from the list above. Add -s or -es, -ing, and -ed to the base word. On each line, write a sentence that shows the meaning of each form of the word.

1. \_\_\_\_\_
- \_\_\_\_\_
- \_\_\_\_\_
- \_\_\_\_\_
- \_\_\_\_\_
- \_\_\_\_\_
- \_\_\_\_\_
- \_\_\_\_\_
- \_\_\_\_\_
- \_\_\_\_\_

2. \_\_\_\_\_

# Profreading for Spelling

Read the following newspaper article. Find and circle the misspelled words.

## Yellow Jackets Win First Game

The stadium was oopen for the game. Coach Smith and her players were ready. The game was soukd out. Not even the cold weather kept people away. The crowd cheered as the team entered the stadium.

The first batter scored a run almost right away. During the game, nine more players followed her lead. The Yellow Jackets left the other team in the shades.

A player told me after the game that they intend to win every game this season. They will be put to the test tomorrow when they play the Colts.

Write the misspelled words correctly on the lines below.

1. \_\_\_\_\_ 6. \_\_\_\_\_
2. \_\_\_\_\_ 7. \_\_\_\_\_
3. \_\_\_\_\_ 8. \_\_\_\_\_
4. \_\_\_\_\_ 9. \_\_\_\_\_
5. \_\_\_\_\_ 10. \_\_\_\_\_

# Long / Spelled i, ie, igh

Read each sentence. Choose the missing word from the box. Write the word in the blank.

find  
sights  
sigh  
fried

climb  
wild  
untied  
midnight

fried  
tie

1. I did not \_\_\_\_\_ the book I was looking for.
2. The clock strikes twelve at \_\_\_\_\_.
3. Jasmine and her family went to Paris to see the \_\_\_\_\_.
4. The \_\_\_\_\_ animal ran through the forest.
5. I would like to \_\_\_\_\_ a mountain some day.
6. I tripped over my shoelaces because they were \_\_\_\_\_.
7. The best dish at this restaurant is \_\_\_\_\_ chicken.
8. "I wish it would stop raining," Manty said with a \_\_\_\_\_.
9. The police officer \_\_\_\_\_ to direct traffic.
10. George Washington once said, "I cannot tell a \_\_\_\_\_."

# Profreading for Spelling

Read the following newspaper article. Find and circle the misspelled words.

## Yellow Jackets Win First Game

The stadium was oopen for the game. Coach Smith and her players were ready. The game was soukd out. Not even the cold weather kept people away. The crowd cheered as the team entered the stadium.

The first batter scored a run almost right away. During the game, nine more players followed her lead. The Yellow Jackets left the other team in the shades.

A player told me after the game that they intend to win every game this season. They will be put to the test tomorrow when they play the Colts.

Write the misspelled words correctly on the lines below.

1. \_\_\_\_\_ 6. \_\_\_\_\_
2. \_\_\_\_\_ 7. \_\_\_\_\_
3. \_\_\_\_\_ 8. \_\_\_\_\_
4. \_\_\_\_\_ 9. \_\_\_\_\_
5. \_\_\_\_\_ 10. \_\_\_\_\_

# Long / Spelled i, ie, igh

Read each sentence. Choose the missing word from the box. Write the word in the blank.

find  
sights  
sigh  
fried

climb  
wild  
untied  
midnight

fried  
tie

1. I did not \_\_\_\_\_ the book I was looking for.
2. The clock strikes twelve at \_\_\_\_\_.
3. Jasmine and her family went to Paris to see the \_\_\_\_\_.
4. The \_\_\_\_\_ animal ran through the forest.
5. I would like to \_\_\_\_\_ a mountain some day.
6. I tripped over my shoelaces because they were \_\_\_\_\_.
7. The best dish at this restaurant is \_\_\_\_\_ chicken.
8. "I wish it would stop raining," Manty said with a \_\_\_\_\_.
9. The police officer \_\_\_\_\_ to direct traffic.
10. George Washington once said, "I cannot tell a \_\_\_\_\_."

# Cause and Effect

Roberto Clemente, Pride of the Pittsburgh Pirates

Introduce Comprehension Cause and Effect

Read the selection below.

The 1920s were a long time ago, but Babe Ruth is still remembered. Many people think that he was the greatest baseball player of all time. He began his career with the Boston Red Sox as a pitcher. Soon however, his batting skill became the focus of attention. He was traded to the New York Yankees in 1920, and his career as a home-run hitter took off. He hit 54 home runs that year. In 1927, he hit 60. That record lasted until 1961.

Perhaps his most famous moment came during the third game of the 1932 World Series against the Chicago Cubs. However, no one knows whether that moment ever really happened! Legend says that when Cub fans were yelling at Ruth, he pointed to center field. He hit the next pitch to the very place he'd pointed to. The ball sailed over the center field wall for a towering home run! Whether true or not, it's a great story.

Complete the T-Map to show causes and effects from the selection.

Cause	Effect

# Spelling Word Sort

Roberto Clemente, Pride of the Pittsburgh Pirates

Spelling Long /

Write each Basic Word under the correct heading.

Long / Spelled /	Long / Spelled /e
Long / Spelled /igh	

Review Add the Review Words to your Word Sort.

Challenge What letter or letters form the long / sound in the two Challenge Words?

Spelling Words	
<b>Basic</b>	1. slight
	2. mild
	3. sight
	4. pie
	5. mind
	6. lie
	7. pilot
	8. night
	9. lie
	10. light
	11. blind
	12. fight
	13. die
	14. midnight
<b>Review</b>	find
	night
<b>Challenge</b>	silent
	frightening

# Cumulative Review

Write a word from the box to complete each sentence.

most	lightning	flowed
slimy	toast	railroad
tries	knights	
glowing	title	

1. Lava \_\_\_\_\_ down the sides of the volcano and into the sea.
2. A bolt of \_\_\_\_\_ suddenly flashed across the sky.
3. The \_\_\_\_\_ of my favorite book is *White Fang*.
4. For breakfast, Karl likes to eat \_\_\_\_\_ with peanut butter.
5. I love to watch the fireflies \_\_\_\_\_ in the dark summer sky.
6. King Arthur and his \_\_\_\_\_ sat at a huge round table.
7. The worm felt \_\_\_\_\_ when I touched it.
8. Always stop, look, and listen before crossing a \_\_\_\_\_ track.
9. The athlete finally jumped over the bar after three \_\_\_\_\_.
10. Lee knew \_\_\_\_\_ of the answers on the test, but not all of them.

# Plural Nouns with -s and -es

1-5. Write singular or plural for each underlined noun.

1. The fans went to find their seals.
2. The popcorn seller brought them two boxes.
3. Other fans passed a giant ball around.
4. A foul ball sailed up into the stands from the field.
5. Some fans had special passes that let them go onto the field.

6-10. Write the plural form of the noun in parentheses to complete the sentence.

6. Two \_\_\_\_\_ had wire mesh that stopped foul balls. (fence)
7. People stood in the \_\_\_\_\_ instead of sitting in their seats. (aisle)
8. The fans clapped for a series of great \_\_\_\_\_ of hard-hit balls. (catch)
9. The scoreboard could not show any \_\_\_\_\_ because that number was broken. (six)
10. There were \_\_\_\_\_ of programs to hand out to the fans. (stack)

# Prefix mis-

Read the letter. Notice the underlined words. Write a reply to this letter. Use at least four of the underlined words in your letter.

Dear Eric,

I did not mean to misbehave or mistreat you. I thought it was funny when someone misprounced your name. I didn't think it would upset you, but I can see that I miscalculated that. If someone said I did not want to be your friend, then they are misformed. Can we please forget about this misunderstanding?

Your friend

---

---

---

---

---

---

---

---

---

---

---

---

Roberto Clemente, Pride of the Pittsburgh Pirates  
Vocabulary Strategies  
Helps you:

# Proofreading for Spelling

Find the misspelled words and circle them.

**Plane Has Narrow Escape**

A brave pilot saved the lives of her passengers yesterday when she saved an airplane from crashing at midnight when her plane began to rock. There was only a slight wind, so she knew her plane was in trouble. An engine was out, and the plane was sinking. Not only that, but thick fog made her have to fly blind. She was in a life spot.

Captain Foster quickly thought of things she mite do. Different ideas went through her mind. She would have to fit to guide her plane to safety.

"I felt some mild fear," she said later, "but I was mainly thinking of how to save the plane and the passengers."

She found the nearest airport on the map and steered toward it. Finally, the airport came in sight. Captain Foster made a perfect landing, and 147 passengers were safe.

Write the misspelled words correctly on the lines below.

1. \_\_\_\_\_ 6. \_\_\_\_\_
2. \_\_\_\_\_ 7. \_\_\_\_\_
3. \_\_\_\_\_ 8. \_\_\_\_\_
4. \_\_\_\_\_ 9. \_\_\_\_\_
5. \_\_\_\_\_ 10. \_\_\_\_\_

Roberto Clemente, Pride of the Pittsburgh Pirates  
Spelling  
Spelling Lists

## Spelling Words

- Basic**
1. sight
  2. mild
  3. sight
  4. pie
  5. mind
  6. tie
  7. pilot
  8. might
  9. lie
  10. light
  11. blind
  12. light
  13. die
  14. midnight
- Review**
- find  
night
- Challenge**
- silent  
lightening

# VCV Words with Long and Short Vowels

Read each sentence. Choose the missing word from the box. Write the word. Then reread the complete sentence.

visit	robot
tiny	hurd
report	decide
flavor	shiver
shiver	gravel
gravel	

- We took a bumpy ride down a \_\_\_\_\_ road in the country.
- Chocolate is my favorite \_\_\_\_\_.
- I \_\_\_\_\_ the amount of sweets that I eat.
- My sister has a collection of \_\_\_\_\_ glass animals.
- I need to pick a topic for my \_\_\_\_\_.
- It was hard to \_\_\_\_\_ which movie to watch.
- The icy wind made me \_\_\_\_\_.
- Steve hopes to \_\_\_\_\_ the Space Museum someday.
- That interesting machine is called a \_\_\_\_\_.

# Sequence of Events

Read the selection below.

Mason was bored. His best friend Jorge was at summer camp. Mason had just finished reading Jorge's letter. The letter said Jorge collected a special badge for each fun activity he learned to do. Mason sighed. He sure wasn't collecting any badges.

Suddenly, Mason's mood changed. "I can collect something!" he thought. "I can hike the mountain trails near here. I'll collect things I find."

That afternoon, Mason and his older brother hiked Rainbow Trail. They found interesting rocks and a stone arrowhead. When he got home, Mason arranged his treasures in shoeboxes. Then he made labels.

After that, Mason hiked and collected every day. He set up the collection on tables in the garage. Then he hung a sign on the garage door.

When Jorge came back, the first thing he noticed was Mason's sign. He read "Mason's Mountain Museum."

Use a Flow Chart to track the order of events in the selection. Then use your Flow Chart to respond to the items below.

1. What happened after Mason got a letter from Jorge?

2. How did Mason's feelings change after he had started his collection?

Max's Words  
Introduce Comprehension:  
Sequence of Events.

Max's Words  
Phonics: Words with the  
VCV Pattern

# VCV Words with Long and Short Vowels

Read each sentence. Choose the missing word from the box. Write the word. Then reread the complete sentence.

visit	robot
tiny	hurd
report	decide
flavor	shiver
shiver	gravel
gravel	

- We took a bumpy ride down a \_\_\_\_\_ road in the country.
- Chocolate is my favorite \_\_\_\_\_.
- I \_\_\_\_\_ the amount of sweets that I eat.
- My sister has a collection of \_\_\_\_\_ glass animals.
- I need to pick a topic for my \_\_\_\_\_.
- It was hard to \_\_\_\_\_ which movie to watch.
- The icy wind made me \_\_\_\_\_.
- Steve hopes to \_\_\_\_\_ the Space Museum someday.
- That interesting machine is called a \_\_\_\_\_.

## More Short and Long Vowels

Write each basic word in the box where it belongs. You will write words with two vowel sounds in more than one box.

Vowel sound in <i>rope</i>	Vowel sound in <i>meet</i>
Vowel sound in <i>came</i>	Vowel sound in <i>bite</i>
Vowel sound in <i>blue</i>	Vowel sound in <i>flat</i>
Vowel sound in <i>cup</i>	Vowel sound in <i>dress</i>
Vowel sound in <i>skip</i>	Vowel sound in <i>odd</i>

**Challenge** Add the Challenge Words to your Word Sort.

## Cumulative Review

Write a word from the box to complete each sentence. Then read the complete sentence.

pilot	planet	tiger
second	visit	bacon
flavor	finish	cabins

- Can we play outside after we \_\_\_\_\_ our homework?
- My cousins came to \_\_\_\_\_ us last summer.
- As we were leaving the plane, the \_\_\_\_\_ shook my hand.
- The scouts stayed in small \_\_\_\_\_ near the lake.
- Chocolate is the \_\_\_\_\_ of ice cream that I like best.
- Do you want \_\_\_\_\_ with your eggs?
- Look! That reddish light in the sky is the \_\_\_\_\_ Mars!
- Brad came in \_\_\_\_\_ in the race, right behind Jay.
- We watched a \_\_\_\_\_ sleep under the tree.



## Suffixes -er and -or

**Max's Words**  
Vocabulary Strategies:  
Suffixes: -er and -or

Write a sentence using the pair or group of words provided. Make sure the sentence helps the reader understand the meanings of the provided words. (You may add -s to these words.)

1. collector, traveler

\_\_\_\_\_

\_\_\_\_\_

2. pitcher, catcher, player

\_\_\_\_\_

\_\_\_\_\_

3. writer, illustrator

\_\_\_\_\_

\_\_\_\_\_

4. painter, director

\_\_\_\_\_

\_\_\_\_\_

5. buyer, seller

\_\_\_\_\_

\_\_\_\_\_

## Action and Being Verbs

**Max's Words**  
Grammar:  
What is a verb?

1-5. There is one action verb in each sentence. Write the verb on the line.

1. Randy finds words in a book. \_\_\_\_\_
2. His friends search for words everywhere. \_\_\_\_\_
3. His grandmother cut words from a letter. \_\_\_\_\_
4. Words hide in odd places. \_\_\_\_\_
5. Nobody kicked the box of words. \_\_\_\_\_

6-10. Write the being verb on the line. Write present or past for each verb.

6. Words are hard to find sometimes. \_\_\_\_\_
7. I am able to find words everywhere. \_\_\_\_\_
8. You were sweet to look for me. \_\_\_\_\_
9. We are tired of finding words. \_\_\_\_\_
10. The teachers were in their rooms with words. \_\_\_\_\_

# More Short and Long Vowels

Find the misspelled words and circle them.

Jun 1: This was a great day! It started out like any other Friday. I did all the usual stuff. I got dressed, put on my shoes and socks, and ate some toast and jam. But as I started to comb my hair, I heard kids playing outside. For a minute, I thought it might be a holiday. Then suddenly I remembered that school is out. This is the first day of summer vacation! There are no more math tests, no more piles of homework, and no more long days of sitting still.









The rest of the day was perfect. I played kickball with my friends, rode my bike, and went to the pool. It was so much fun that I think I'll do it all again tomorrow. Or maybe I'll just watch TV and take it easy. I love summer!

Write the misspelled words correctly on the lines below.

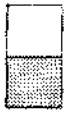

















1. \_\_\_\_\_ 6. \_\_\_\_\_
2. \_\_\_\_\_ 7. \_\_\_\_\_
3. \_\_\_\_\_ 8. \_\_\_\_\_
4. \_\_\_\_\_ 9. \_\_\_\_\_
5. \_\_\_\_\_ 10. \_\_\_\_\_

## PRACTICE Comparing Fractions

Draw a line under the fraction that is more.

1.  $\frac{1}{3}$    $\frac{2}{3}$  
2.  $\frac{1}{2}$    $\frac{3}{4}$  
3.  $\frac{3}{7}$    $\frac{1}{7}$  
4.  $\frac{5}{8}$    $\frac{1}{4}$  

Compare. Write  $>$ ,  $<$ , or  $=$  for  $\bigcirc$ .

5.   $\frac{1}{6}$    $\frac{4}{6}$  
6.   $\frac{1}{3}$    $\frac{1}{3}$  
7.   $\frac{1}{3}$    $\frac{1}{3}$  
8.   $\frac{3}{6}$    $\frac{4}{10}$  
9.   $\frac{5}{8}$    $\frac{3}{4}$  
10.   $\frac{1}{4}$    $\frac{8}{8}$  

© Holt, Rinehart and Winston, Publishers • 3

**PRACTICE**

**Guess and Check**

To solve, make a guess. Then, check your answer.

1. Tom watched 15 TV shows in the last 3 weeks. Each week, he watched 1 more show than he watched the week before. He never watched more than 7 shows in a week. How many shows did he watch each week for the last 3 weeks?

2. Sylvia is going to the store to buy a TV schedule. It costs \$0.85. She has 5 coins in her wallet. They add up to the cost of the guide. What are they?

3. Sylvia is looking at the TV schedule. She decides to play a game with Tom. She tells him that cartoons will be shown on 2 channels whose sum is 15. Tom knows the numbers of the channels. They are Channels 3, 4, 6, 8, 11, 13. What 2 channels will show cartoons?

4. Tom is trying to figure out how long 3 popular shows have been on TV. Sylvia tells him that the sum of the shows' ages is 12 years. The ages of all 3 shows are even numbers. All the shows began in different years. How long have the shows been on TV?

**PRACTICE**

**Probability**

Solve.

All the students in Mrs. Stevens's class either walk or take the bus to school. Use the table to answer the questions.

Way to school	Tally
Walk	
Take bus	

- How many students are there in Mrs. Stevens's class?
- How many of the students walk to school?
- How many of the students take the bus?
- What is the probability that a student in Mrs. Stevens's class takes the bus to school?

Ring the most sensible answer.

- Ira flipped a coin 10 times. It came up heads 1 times.
- Ira flipped a coin 10 times. It came up tails 5 times.
- Lisa flipped a coin 15 times. It came up heads 7 times.
- Lisa flipped a coin 15 times. It came up tails 3 times.

Write a fraction for each probability.

- There are 2 eggs in the refrigerator, 1 hard-boiled and 1 raw. Mrs. Wolfman forgets which egg is cooked. What is the probability that she will pack the raw egg for her lunch?
- What is the probability that she will pack the hard-boiled egg?

**PRACTICE** Decimals

Write the decimal.

- $4\frac{7}{10} =$  \_\_\_\_\_
- $7\frac{75}{100} =$  \_\_\_\_\_
- $1\frac{5}{10} =$  \_\_\_\_\_
- $2\frac{13}{100} =$  \_\_\_\_\_

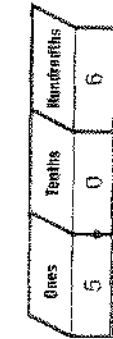
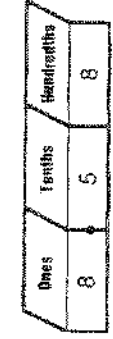

- six and sixty-seven hundredths
- one and fourteen hundredths

Solve.

How many dollars are in Andy's penny jar each month?

Month	Pennies	Dollars
9. January	152	\$1.52
10. February	107	_____
11. March	139	_____
12. April	180	_____
13. May	219	_____
14. June	265	_____
15. July	308	_____
16. August	351	_____
17. September	397	_____
18. October	437	_____
19. November	480	_____
20. December	521	_____

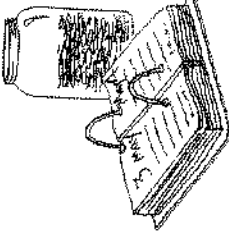

**PRACTICE** Decimals and Fractions

Write the decimal for the amount of ice left in these trays.

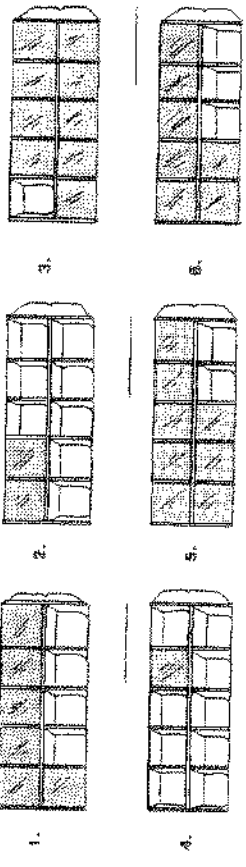

Write the decimal.

- $\frac{4}{10} =$  \_\_\_\_\_
- $\frac{7}{10} =$  \_\_\_\_\_
- $\frac{3}{10} =$  \_\_\_\_\_

10. six tenths = \_\_\_\_\_

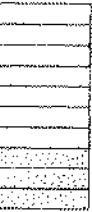

11. one length = \_\_\_\_\_ of the wallpaper hung.



12. eight tenths = \_\_\_\_\_ of the floor tiled.



13. Joel has \_\_\_\_\_ of the lawn mowed.



Write the word name of each decimal.

- 0.5 \_\_\_\_\_
- 0.2 \_\_\_\_\_
- 0.9 \_\_\_\_\_

**PRACTICE** Comparing and Ordering Decimals

Compare. Write  $>$ ,  $<$ , or  $=$  in the .

- 1.  1.2  1.5
- 2.  5.1  5.5
- 3.  7.6  6.7
- 4.  12.1  11.2
- 5.  3.0  3.9
- 6.  6.2  6.20
- 7.  8.5  8.3
- 8.  9.9  9.1

Write the decimals in order from the least to the greatest.

- 9. 1.2, 1.0, 1.9 \_\_\_\_\_
- 10. 5.6, 6.5, 5.8 \_\_\_\_\_
- 11. 3.2, 3.3, 3.0 \_\_\_\_\_
- 12. 11.9, 10.9, 11.0 \_\_\_\_\_
- 13. 7.6, 7.9, 7.8 \_\_\_\_\_
- 14. 22.9, 20.9, 21.0 \_\_\_\_\_

Ring the decimal that does not belong in each row.

- 15. 1.5    1.6    1.9    1.7
- 16. 3.6    3.5    3.4    3.9
- 17. 6.0    6.8    6.1    6.2
- 18. 3.0    2.3    2.4    2.5

**PRACTICE** Subtracting Decimals

Subtract.

- 1.  $75.4 - 10.3 =$
- 2.  $62.2 - 10.4 =$
- 3.  $9.9 - 5.1 =$
- 4.  $7.4 - 4.5 =$
- 5.  $6.3 - 4.8 =$
- 6.  $72.1 - 53.8 =$
- 7.  $\$3.60 - 2.50 =$
- 8.  $7.5 - 2.8 =$
- 9.  $87.1 - 49.0 =$
- 10.  $9.88 - 8.89 =$
- 11.  $74.8 - 60.5 =$
- 12.  $46.8 - 18.9 =$
- 13.  $5.1 - 4.5 =$
- 14.  $\$8.64 - 4.38 =$
- 15.  $9.86 - 2.51 =$
- 16.  $6.3 - 3.4 =$
- 17.  $9.6 - 6.5 =$
- 18.  $59.8 - 45.8 =$
- 19.  $\$8.99 - \$2.71 =$
- 20.  $96.3 - 77.9 =$
- 21.  $5.79 - 1.53 =$

**TIC-TAC-TOE!**

Each tic-tac-toe board has one correct subtraction problem across or down. Can you find it?

7.57	5.10	3.17	9.88	3.02	9.35
4.62	1.90	2.72	8.04	2.07	6.97
1.85	4.90	1.85	4.86	1.45	2.38

**PRACTICE**

**Metric Units of Length**

Complete. Write *centimeter*, *meter*, or *kilometer*.

1. 100 \_\_\_\_\_ = 1 meter
2. 1,000 meters = 1 \_\_\_\_\_
3. 2 meters = 200 \_\_\_\_\_
4. 6 \_\_\_\_\_ = 6,000 meters

Complete.

5. 3 m = \_\_\_\_\_ cm
6. 2 km = \_\_\_\_\_ m
7. 600 cm = \_\_\_\_\_ m
8. 5,000 m = \_\_\_\_\_ km
9. 9 m = \_\_\_\_\_ cm
10. 700 cm = \_\_\_\_\_ m

Choose the unit that you would use to measure each. Write *cm*, *m*, or *km*.

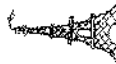
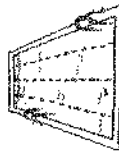

Draw a line from the object to the unit you would use to estimate its length.



centimeter



meter



kilometer

Use with pages 270–271.

**PRACTICE**

**Help File Review**

Mrs. Bradburn wants to hang 9 pictures in her classroom. Each picture is 34 cm wide. She asks Ms. Carlos, the carpenter, to put a strip of wood on the wall. Mrs. Bradburn will staple the pictures to the strip. How long must the strip of wood be?

Write the letter of the best answer.

1. Lee can't figure out what Mrs. Bradburn needs from Ms. Carlos. "What does Ms. Carlos need to know?" he asks. Where should Lee look in the Help File?
  - a. Questions
  - b. Tools
  - c. Solutions
  - d. Checks
2. Juanita says, "I know what Ms. Carlos needs to know. I know what to do, but I don't remember how!" Where should Juanita look in the Help File?
  - a. Questions
  - b. Tools
  - c. Solutions
  - d. Checks

Solve. Use the Help File if you need to.

3. Ms. Carlos makes the strip the exact length needed. How long is the strip of wood? \_\_\_\_\_
4. The children decide that it would look better to put an equal section of the strip on each of two walls. How long will the strip be on each wall? \_\_\_\_\_
5. Mrs. Bradburn staples 4 of the pictures to one strip. There are 5 pictures left. Can she fit them all on the other strip? \_\_\_\_\_
6. Mrs. Bradburn sees that she has made a mistake. She asks Ms. Carlos to make one strip longer. How long must it be so that the last picture can be hung? \_\_\_\_\_

7. Is there space between the 4 pictures on the first strip? \_\_\_\_\_









- a. Mrs. Bradburn used 3 staples to hang each picture. How many staples did she use for all the pictures? \_\_\_\_\_

Use with pages 274–275.

**PRACTICE**

**Grams and Kilograms-Celsius**

Mr. Greengrocer uses two different scales. One shows grams, the other kilograms. Ring which scale he should use.

- 1.  gram kilogram
- 2.  gram kilogram
- 3.  gram kilogram
- 4.  gram kilogram
- 5.  gram kilogram
- 6.  gram kilogram
- 7.  gram kilogram
- 8.  gram kilogram

Match each thermometer with a likely description.

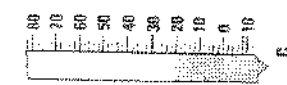
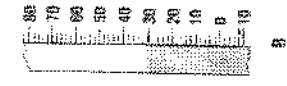
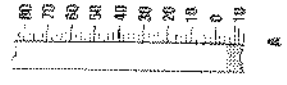

- 9. very hot and sunny \_\_\_\_\_
- 10. cool and cloudy \_\_\_\_\_
- 11. cold and snowing \_\_\_\_\_

Use with pages 276-279.

**PRACTICE**

**Problem-Solving Practice**

Ring the letter of the correct number sentence.

- 9. There are 9 divers studying undersea life. Each diver has 3 notebooks to fill with notes. What is the total number of notebooks that the divers have?  
a.  $9 + 3 = ?$   
b.  $9 \times 3 = ?$
- 10. One young dolphin weighs 350 pounds. A giant sea turtle weighs 1,150 pounds more than the dolphin. How much does the sea turtle weigh?  
a.  $1,150 + 350 = ?$   
b.  $1,150 - 350 = ?$

Estimate to solve.

- 11. In one part of the ocean, a diver counted 52 spider crabs, 16 sea urchins, and 73 starfish. About how many creatures did the diver count?
- 12. In another part of the ocean, the diver found 61 mackerel, 36 herring, and 17 angler fish. About how many fish did the diver count in all?

Without finding the exact answer, ring the letter of the answer that is most reasonable.

- 13. The nets on one fishing boat caught 470 fish one day. On the next day, they caught 590 fish. How many fish were caught in the two days?  
a. 200      b. 600      c. 1,060
- 14. Three shrimp boats landed. Boat A had 3,000 shrimp. Boat B had 4,000. Boat C had 2,700. How many shrimp were there in all?  
a. 6,200      b. 1,200      c. 9,700

Ring the letter of the correct answer.

- 15. Shrimp boats carry crews of from 4 to 10 people. There are 7 boats. Each carries the smallest possible crew. Do these boats carry more or fewer than 30 people in all?  
a. Yes, they do.  
b. fewer than 30  
c. more than 30
- 16. One diver was exploring a sunken ship. She made 3 dives per day from Monday through Friday. How many dives did she make Tuesday and Wednesday?  
a. yes  
b. 15 dives  
c. 6 dives

Use with pages 280-281.

**PRACTICE**

**Cups, Pints, Quarts, and Gallons**

Complete.

1. How many cups in 1 pint of milk? \_\_\_\_\_
2. How many pints in 1 quart of milk? \_\_\_\_\_
3. How many quarts in 1 gallon of milk? \_\_\_\_\_



Complete.

4. 4 pt = \_\_\_\_\_ qt      5. 6 pt = \_\_\_\_\_ qt      6. 2 c = \_\_\_\_\_ pt
7. 4 c = \_\_\_\_\_ pt      8. 12 qt = \_\_\_\_\_ gal      9. 8 pt = \_\_\_\_\_ qt
10. 8 c = \_\_\_\_\_ pt      11. 16 qt = \_\_\_\_\_ gal      12. 5 gal = \_\_\_\_\_ qt

Ring the better measure.

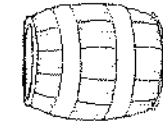

13.

c gal



14.

c gal



15.

c gal



16.

c qt



17.

c pt

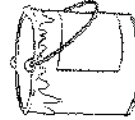

18.

c gal

**PRACTICE**

**Customary Units of Length**

Complete. Write *in.*, *ft.*, *yd.*, or *mi.*

1. 12 \_\_\_\_\_ = 1 foot      2. 3 feet = 1 \_\_\_\_\_
3. 36 \_\_\_\_\_ = 1 yard      4. 5,280 \_\_\_\_\_ = 1 mile

Ring the better unit of measure.

5. I walk to the store to buy milk. The store is only 50 yd mi from my house.
6. The sign on the door says "SMITH'S MARKET" in letters that are 10 in. ft high.
7. Mr. Smith is almost 6 in. ft tall.
8. The milk comes from a farm that is 20 yd mi away.
9. Milk helps me grow. I have grown 3 in. ft since last year.



10.

in.  
ft

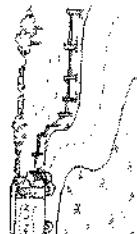

11.

mi  
in



**PRACTICE** Angles

Is this a right angle? Write yes or no.

1.

2.

3.

4.



5.

6.

7.

8.

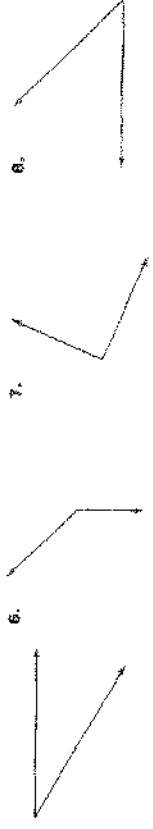

Write how many angles there are in each figure.

9.

10.

11.

12.



13.

14.

15.

16.



**PRACTICE** Using a Map

GREEN RIDGE STATE PARK

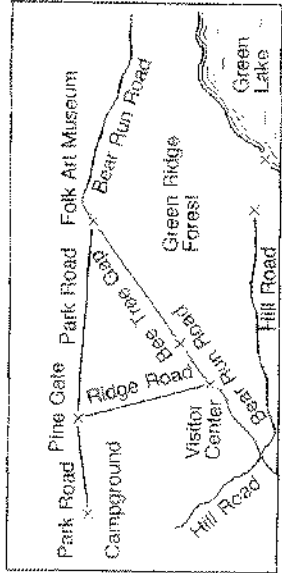

Use the map to solve. Measure from the X's.

- Ralph and Brad ride their bikes on Park Road from the campground to Pine Gate. How far do they ride?
- The boys plan to visit the Folk Art Museum. How long is the shortest path from Pine Gate?

- From the Folk Art Museum, the boys plan to ride to the Visitor Center. How far must they ride from the museum to the center?
- Which two roads meet at a point closest to Bee Tree Gap?

- The boys want to visit Green Lake. They take Hill Road to its end. How far is it from the end of Hill Road to the lake?
- The boys reach Green Lake. They can see a road through the trees. It is in the wrong place to be Hill Road. What road is it?

**PRACTICE** Angles

Is this a right angle? Write yes or no.

1.

2.

3.

4.



5.

6.

7.

8.

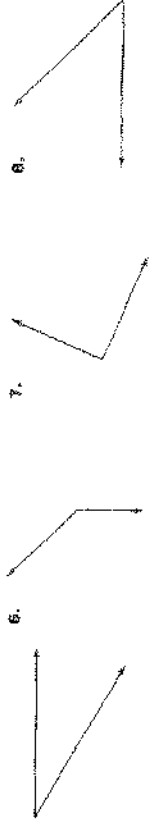

Write how many angles there are in each figure.

9.

10.

11.

12.

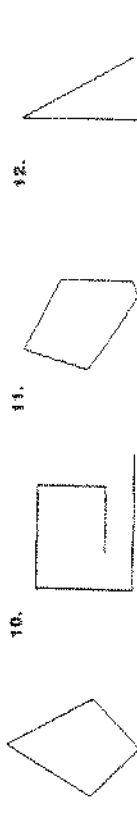

13.

14.

15.

16.



**PRACTICE** Using a Picture

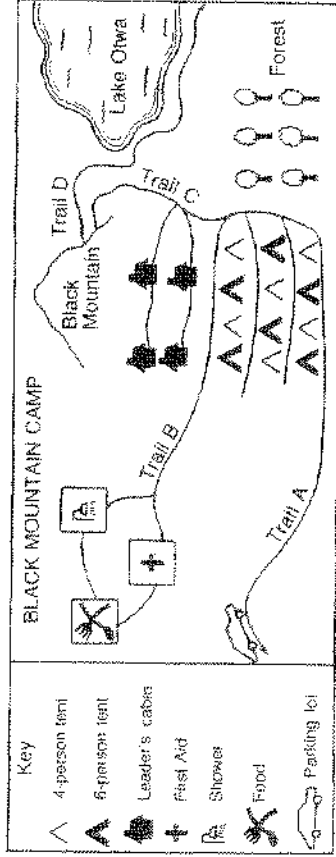

Use the picture to answer these questions.

- There are 12 leaders at the camp. The same number of leaders stay in each cabin. How many stay in each cabin?
- The campers fill all the 4-person tents. They fill 5 of the 6-person tents. How many campers are there?
- How many campers could all the tents hold?
- Do the campers walk by First Aid on their way to the showers?
- A leader is going to meet some parents in the parking lot. He starts from one of the leader's cabins. Which trails should he follow?
- The campers are going on a trip to Black Mountain. What is the shortest path from the campsite?
- The 54 campers and 12 leaders eat together. They sit in groups of 6. How many tables are there?

**PRACTICE** Lines of Symmetry

Ring each picture in which the dotted line is a line of symmetry.

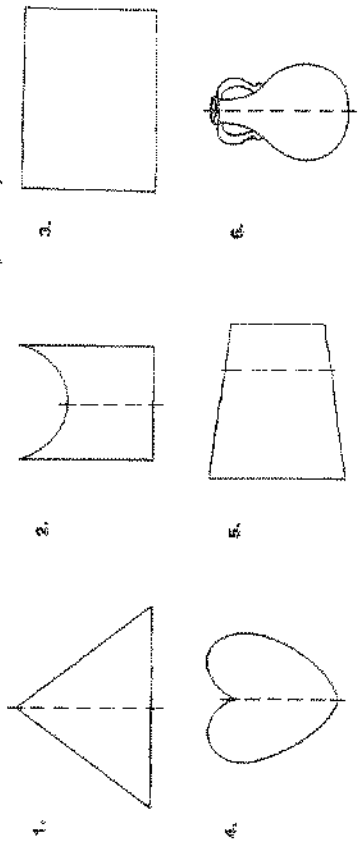

Ring each symmetric figure. Then use a ruler to draw a line of symmetry.

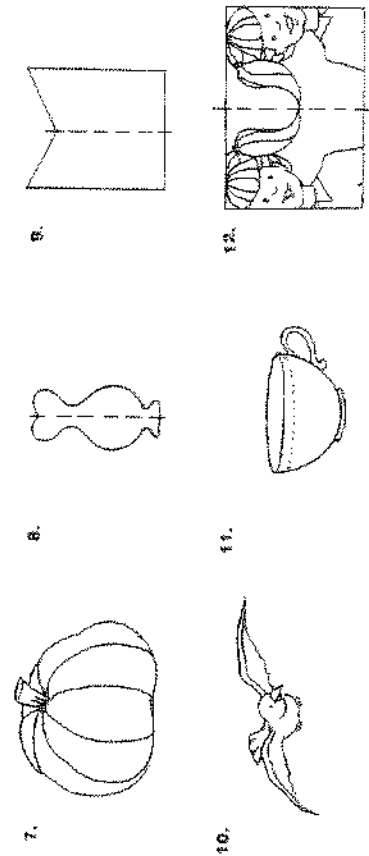

Write three letters of the alphabet that are not symmetric.

**PRACTICE**

**Making a Picture, a Diagram, or a Model**

Solve. Draw a picture if it will help you.

1. The crocodiles are in the last cage of the reptile building. The alligators are 2 cages away. The boas are between the crocodiles and the alligators. On the other side of the alligators is the rattlesnake. In the first cage is a lizard. Between the lizard and the rattlesnake is a turtle. How many cages are in the reptile building?

2. Which reptile lives in the third cage?

3. In the birdhouse, the myna is three cages away from the door. The parrots are in the last cage. eight cages from the myna. How many cages are in this part of the birdhouse?

4. The cockatoo is in the middle of all the cages. What is the number of its cage?

5. There are 7 ducks on the edge of the Science Center pond. There is a white duck on each end. Next to the white duck at the left is a brown duck. Four ducks from the brown duck is a spotted duck. Three ducks to the left of the spotted duck is a mallard. The two ducks to the right of the mallard are both black. What is the color of the middle duck?

**PRACTICE**

**Space Figures**

Look at the first figure in each row. Then ring the object that has the same shape.

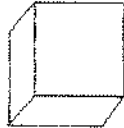
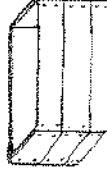
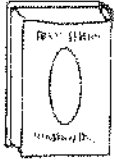

What shape is

- a. a box of tissues?
- b. a grapefruit?
- c. a soup can?

**PRACTICE** Volume

The volume of a box is equal to the number of cubic units that will fit inside it.  
 = 1 cubic unit. Write the volume of each box in cubic units.

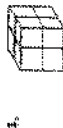
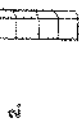

© The McGraw-Hill Companies, Inc.

**PRACTICE** Using a Graph

Mr. Jovan asked each student to write one thing that made him or her happy. He made a bar graph to show the students' answers. Use Mr. Jovan's bar graph to answer these questions.

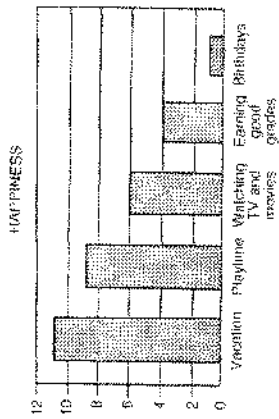

Write the letter of the correct answer.

- What was the most common reason given for happiness?  
 a. vacation  
 b. watching TV and movies  
 c. birthdays
- How many children said getting good grades makes them happy?  
 a. 6  
 b. 4  
 c. 1

Solve.

- Were more students happy watching TV and movies or playing?  
 \_\_\_\_\_
- How many more students were happier watching TV and movies than getting good grades?  
 \_\_\_\_\_
- Mr. Jovan thought many students would write "birthdays." How many students *did not* write "birthdays"?  
 \_\_\_\_\_
- How many students are in Mr. Jovan's class?  
 \_\_\_\_\_
- Can you tell from the bar graph how many boys were happy about going on vacation?  
 \_\_\_\_\_
- Do other things make Mr. Jovan's class happy?  
 \_\_\_\_\_

**PRACTICE** Reading/Graphing Number Pairs

Answer the questions for each graph.

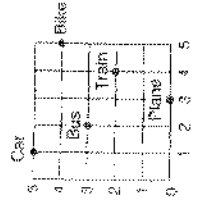

1. What is the number pair for the bicycle? \_\_\_\_\_
2. Go over 1 and up 5. What do you see? \_\_\_\_\_
3. What is the number pair for the train? \_\_\_\_\_
4. What is at the number pair (2,3)? \_\_\_\_\_

Write the letter for each of the following number pairs.

5. (2,5) \_\_\_\_\_
6. (4,8) \_\_\_\_\_
7. (5,3) \_\_\_\_\_
8. (6,6) \_\_\_\_\_
9. (5,1) \_\_\_\_\_
10. What is the number pair for the letter I? \_\_\_\_\_
11. What is the number pair for the letter D? \_\_\_\_\_
12. What is the number pair for the letter A? \_\_\_\_\_

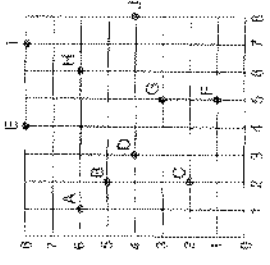

**PRACTICE** Estimating Products

Estimate. Use the front digit to compute your answer.

1.  $\begin{array}{r} 38 \\ \times 2 \\ \hline \end{array}$
2.  $\begin{array}{r} 29 \\ \times 5 \\ \hline \end{array}$
3.  $\begin{array}{r} 32 \\ \times 3 \\ \hline \end{array}$
4.  $\begin{array}{r} 62 \\ \times 6 \\ \hline \end{array}$
5.  $\begin{array}{r} 52 \\ \times 4 \\ \hline \end{array}$
6.  $\begin{array}{r} 46 \\ \times 5 \\ \hline \end{array}$
7.  $\begin{array}{r} 77 \\ \times 2 \\ \hline \end{array}$
8.  $\begin{array}{r} 82 \\ \times 7 \\ \hline \end{array}$
9.  $\begin{array}{r} 45 \\ \times 6 \\ \hline \end{array}$
10.  $\begin{array}{r} 14 \\ \times 9 \\ \hline \end{array}$
11.  $\begin{array}{r} 270 \\ \times 3 \\ \hline \end{array}$
12.  $\begin{array}{r} 412 \\ \times 4 \\ \hline \end{array}$
13.  $\begin{array}{r} 734 \\ \times 3 \\ \hline \end{array}$
14.  $\begin{array}{r} 433 \\ \times 2 \\ \hline \end{array}$
15.  $\begin{array}{r} 205 \\ \times 9 \\ \hline \end{array}$
16.  $\begin{array}{r} 670 \\ \times 7 \\ \hline \end{array}$
17.  $\begin{array}{r} 542 \\ \times 8 \\ \hline \end{array}$
18.  $\begin{array}{r} 751 \\ \times 5 \\ \hline \end{array}$
19.  $\begin{array}{r} 896 \\ \times 2 \\ \hline \end{array}$
20.  $\begin{array}{r} 325 \\ \times 5 \\ \hline \end{array}$

Estimate by multiplying the number in each doorway by the number on the elevator. Use the front digit to compute your answer. Write your answer in the empty doorway.

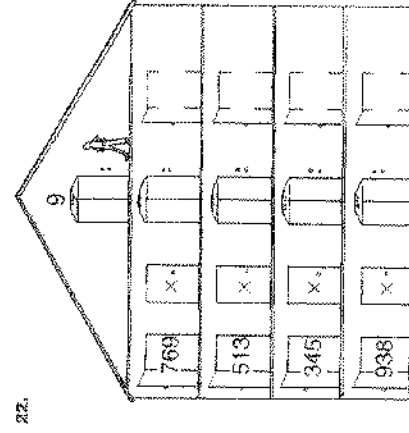
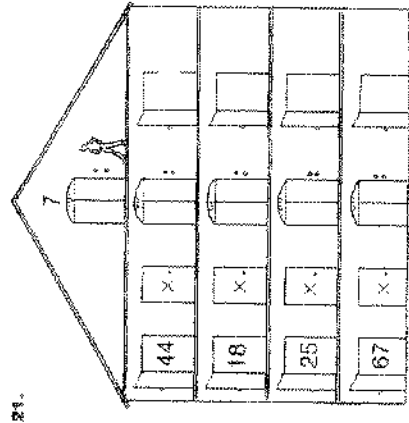

Trace.

h h h h h h h h h h

h h h h h h h h h h

h h h h h h h h h h

h h h h h h h h h h

h h h h h h h h h h