

Development of Information and Communication Technology (ICT) in Container Terminal for Speed up Clearance Process

Evizal Abdul Kadir

Department of Information Technology, Faculty of Engineering, Universitas Islam Riau, Jl. Kaharuddin Nasution, Pekanbaru, Riau, Indonesia 28284
Email: evizal@eng.uir.ac.id

Abstract—Currently container terminals are busy to handle high volume of container shipping movement. Conventional operational procedures have difficulties in handling containers movement, thereby slowing clearances and even resulting in some administrative issues in terminal operation. This paper presents an development of Information and Communication Technology (ICT) in a container terminal in order to speed up clearance process. A business process is proposed in container terminal for management system operational flow. Radio Frequency Identification (RFID) technology and ICT are incorporated for the purpose of identifying driver, vehicle, e-seal, and number of containers. The RFID middleware manages all the information between Gate Checker (GC) and Container Terminal Management System (CTMS), as well as RFID reader. The middleware receives information requested by GC from reader and is then verified by CTMS database. Both types of passive and active RFID tags are used in operation of container terminal. In order to comply with the global standard of container terminal ports, a passive RFID was used for driver and vehicle tag, while for container tag used e-seal which is an active RFID tag. The proposed system was implemented and tested at a private Container Port. ICT system implementation at receiving station gate of the container terminal will reduce truck queue and manpower in-charge for operation. The clearance process in conventional manual operational procedure is significantly reduced from average 248 second per container to 57 second per container.

Index Terms—Container, ICT, RFID, middleware, e-seal

I. INTRODUCTION

Container shipping movement between ports for export and import of goods in the world keeps increasing on a yearly basis. Export and import are mostly done in container system and sea freight is normally used for efficient shipping cost. Seaborne system is identical to the container and container terminal at sea port. As reported at United Nations Conference on Trade and Development (UNCTAD), the volume of container shipment across the world is 170 million Twenty-Foot Equivalent Units (TEUs) container during 2014 [1]. Global container trade is projected to grow by 5.6% in every year, driven among others by improved prospects for mainline East-West trade. Shipping lines cover an estimated 52% from total

container in global trade by seaborne according to UNCTAD 2013 data [2]. This is due to increasing number of goods and products being transported.

In recent year, goods and products delivery safety are being given attention by the parties involved such as consignment, freight forwarder, shipping liner and container terminal. Safety and tracking system are important in order to ensure safe delivery at various destinations. Container tracking and monitoring systems have already been implemented at some container ports in order to monitor container movement and give alert in case of problems. Most of the systems use RFID, Global Positioning System (GPS) and Wireless Sensor Network (WSN). ICT implementation in container terminal operational systems and RFID technology were already commissioned in a few container ports in the world; leading to higher efficiency and thereby saving operational costs. Today, some of ports are equipped with RFID technology in order to capture container e-seal; accordingly the world shipping council top 20 ports used RFID technology for container tagging [3]. However, some issues are still posing limitations, which motivated and need further improvements in these systems.

II. RELATED WORKS

This section presents some of the related work on the use of ICT and RFID technologies in container terminal management system for efficient and faster operational procedure. In [4], RFID technology and GPS were used in a shipping container, where each container was equipped with nodes and neighbor container to send proximity to Base Station (BS). Proximity data are combined to determine container position at the BS. The use of RFID technology is used only to locate container positions in container yard and also analyze the accuracy of data sent.

Container terminal operation system to handle container movement from yard to seaside and other storage location was discussed in [5]. The paper presented an overview of transport operations; the material handling equipment used, and highlighted current industry trends and developments. The current operational paradigms of transport operations were challenged. Lastly, new avenues for academic research were identified, based on current trends and

developments in the container terminal industry. However, discussions on container at gate or receiving side were neglected. In [6] a server for centralizing authentication database for an RFID system was presented. The method used was renewable identity (ID) approach with a big central database, being the current approach to achieve user data security, privacy and authentication. A new protocol with two original approaches was proposed. These are label sharing approach to protect customer and the removable central database approach to enhance system mobility is proposed in this paper. Integration on RFID technology with terminal management system was proposed in [7], in which the RFID tag was used and tagged into the container. Then tag information was shared to other related departments, such as logistic, warehouse, and planning.

RFID technology was implemented in Jebel Ali Port, United Arab Emirates (UAE), in order to increase the reliability and efficiency of the port's operations [8]. Each of containers was tagged by RFID tag which helps in real-time identification and tracking of containers. The system also ensured security when sending out containers out of port area. The method used to define a container was based on the FCAPS network management model. Implementation of ICT in Logistics Service Providers (LSPs) was presented in [7]. Through multiple-case of analysis, the proposed ICT model proved to be suitable for supporting a step-by-step ICT implementation in LSPs.

RFID technology continues to gain more and more attention in many industrial fields of application, including shipping and container ports. This article proposes a novel RFID tag filtering technique/algorithm to ensure smooth container management system operational flow. Application of ICT in the container terminal was discussed, where pervasive computing technologies of RFID were used for investigating Real Time Locating System (RTLS) and also mesh network for container terminal efficiency [9]. Moreover, the use of RFID technology in container terminal for tracking and allocation of container in yard area and also container traceability were presented in [10]-[12]. Algorithm and scheduling of container planning were also discussed and simulation of optimization container clearance in temporary place or storage in yard area to achieve faster container movement. The integration and optimization of container scheduling using Particle Swarm Optimization (PSO) in container terminal were presented in [13]-[15].

Moreover, the use of RFID technology in container terminal for tracking and allocation of container in yard area and also container traceability were presented in [10]-[12]. Algorithm and scheduling of container planning were also discussed and simulation of optimization container clearance in temporary place or storage in yard area to achieve faster container movement. The integration and optimization of container scheduling

using Particle Swarm Optimization (PSO) in container terminal were presented in [13], [16]-[18].

The use of RFID technology in container terminal has recently increased due to its numerous advantages. Some of them are (i) capturing of multiple information in many objects, (ii) high throughput of RFID reader and anti-collision protocol and algorithm (iii) emergence of EPC global network and RFID technology for privacy of information privacy and (iv) sensor tag middleware for container monitoring in logistics port system [19]-[22].

III. CURRENT OPERATIONAL PROCEDURES

Currently container terminal operations running use IT. However, the IT systems (called CTMS) were only implemented in planning department, container system for planning, registration, booking and request. The container gate-in for the reception of containers to be exported still use manual systems controlled by human beings. Every container is received for inspection and manually keyed-in by container staff at receiving office and then the verification is connected to CTMS system. Fig. 1 shows the layout of a container terminal gate-in that is currently used for receiving. Implementation of the ICT and RFID technologies consist of six lanes, two lanes for request pick-up or import and the rest of four lanes for laden container receiving with weight balance.

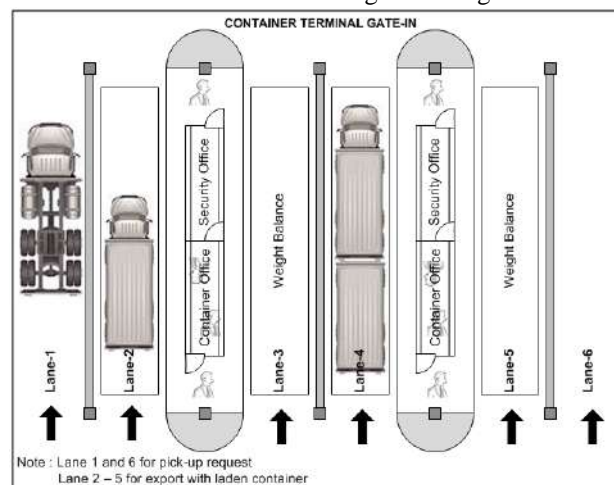

Fig. 1. Layout of container terminal gate-in.

Container terminal gate-in is where containers are exported and request pick-up. Mostly gate-in receives laden containers and sometimes receives empty containers. Before container can be exported to vessel, the forward agent must first register the details of container information, such as driver name, vehicle and truck numbers, and weight of goods, contents and e-seal number. A systematic procedure must be observed before sending containers. All of its details must be updated before the truck arrival at container terminal gate-in. There are several problems with the current operational procedures, such as slow container processing and clearance time by officer, queue on the road, inefficient operational procedure due to manual processes.

For example, the driver needs to go down and pass document manually to officer. Many members are also required to process a container, increasing the risk of human errors. A very important issue is slow processing time, in which the average for the six lanes maximum can process 300,000 TEUs container a year.

CTMS Container export/storage procedures:

- 1) Export Booking (EB) – This enables Container Operator (CO) to create export booking detail (mandatory) by inputting JPVC, POD, size/type, cargo code type, quantity and to assign the booking to Forward Agent (FA), only FA code that are registered with CTMS will be listed.
- 2) Pre-Advise (PA) – This enables the FA/CO to input export or import storage container details. For export user has to select JPVC, export booking number assigned by CO and then input the necessary container information before inputting container number/s. Import storage is for container to be received into container yard and then deliver out by truck and train.
- 3) Pre-Gate In – This enables Haulier (HL) to select container and input container arrival date/ time (ETA) at container terminal Gate-In. All prime moves and trailers must be pre-registered with correct codes and tire weights.
- 4) Terminal Gate-In Inspection – This allows the container to be inspected physically to verify container info against pre-advise/pre-gate before container is allowed to enter terminal. The container staff will reject container without pre-advise, wrong container number & seal number, seal not intact/broken, Dangerous Good (DG) / Hazard (HZ) hold, severe damage or cargo leaking, over weight and prime mover or trailer not registered and matched with truck code in pre-gate.

IV. IMPLEMENTATION OF ICT AND RFID TECHNOLOGY

This paper proposes the development of ICT technology in a container terminal is done at a container port, where the terminal services are mostly for export / import of goods. Fig. 2 shows a picture taken at container terminal gate-in for receiving container to send to yard area before being sent to vessel for export. The gate-in container terminal has six lanes. The development of ICT system and RFID technology into port operation is expected to solve or overcome current issues [23].



Fig. 2. Truck driver register by manually to gate operator.

The ICT is currently running in the planning department for container planning, management and registration. The CTMS serves for container planning, arrangement, storage in yard area and also planning for loading in vessel including container registration and request pick-up for forwarder agent. Development and extension of current ICT system to terminal gate for container clearance has very high impact in the operational system. Implementation of the system is to follow standardization that is already implemented in other ports worldwide and is able to overcome and solve some issues in operation such as:

- 1) Reduce long queue at gate-in or receiving area.
- 2) Improve efficiency of container clearance and real time authentication at receiving gate-in.
- 3) Real time update of container information into system, once RFID tagged at container to enter receiving gate.
- 4) Provide real time visibility of container status.
- 5) Improve security of container by using e-seal.
- 6) Reduce manpower and operation staff.
- 7) Improve customer service by fast clearance at receiving.
- 8) Online access of container status in real time.

Process flow after development of the ICT system is changed compared to the previous manual operational system. The container or prime mover enters into the receiving lane and the system checks whether the truck carries a container or only requests pick-up with chassis. The RFID system reads the driver tag, vehicle tag and e-seal, (if e-seal number is not detected, it maybe that the container is not tagged by e-seal). In this procedure driver and vehicle tag are compulsory for every truck or prime mover to enter receiving lane. This regulation is enforced at check point of the container terminal Port Safety Management System (PSMS). After all the information captured and a check of the container weight is made to ensure less than 40 tons as maximum weight for every container, then physical checking by the container officer is made the container is cleared.

A. Business Process at Gate-in

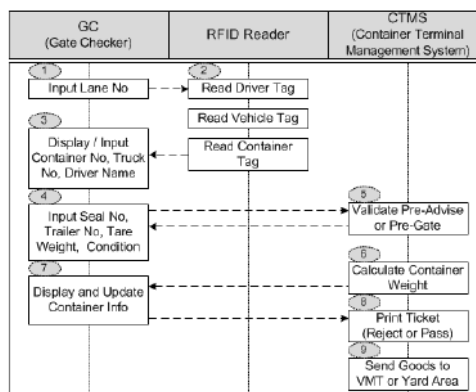

Fig. 3. Proposed business process used RFID technology.

In order to specify and analyze in more detail interconnection to current CTMS, a business process flow is write to show the flow of message pass and transfer.

Fig. 3 shows a business process of container terminal gate-in, where the system is decided into three main parts.

Gate checker is a staff of container terminal, CTMS is current system for container planning and RFID reader is proposed system to be implemented into gate-in receiving area. Flow of the messages from the three big parts is interconnected and dependent, if any of the system is down then the system cannot be run. The process flow is indicated in detail below:

- 1) Gate Checker (GC) input truck lane number.
- 2) RFID reader reads driver tag, vehicle tag and container e-seal number and retrieve information.
- 3) Hand Held Terminal (HHT) or Table PC display driver name, truck number, e-seal and container number.
 - If no container number, GC can input container number manually by key-in on tablet.
- 4) GC input seal number, condition single container or back to back container.
- 5) CTMS validates, driver name, truck number, container number and e-seal no against pre-advise.
- 6) CTMS calculates container weight.
- 7) HHT or Table PC, display lane number, container number, Dangerous Goods (DG).
- Weighting figure, gross container weight, container yard location, handling instruction, status (reject/pass)
- 8) CTMS print ticket with conditions :
 - a. Reject if invalid container number, truck number, e-seal number, DG hold, overweight.
 - b. Pass if valid container information, keep transaction logs, truck number, weighting information.
- 9) CTMS sends passed gate lift-off job to Vehicle Mounting Terminal (VMT) on Rubber Tire Gantry (RTG) yard.

B. Container Seal

There are several types of container seals and normally the use of container seal is according to the value of goods to carry in container. For example steel bend seal for cheaper goods, bolt type which a metal bar with the lock, this type is most commonly use with reasonable price, then for most expensive goods used high quality container seal or even now electronic seal (e-seal). Every container seal has unique number as identity seal ID either mechanical seal or electronic seal. Fig. 4 (a-d) shows types of seals.

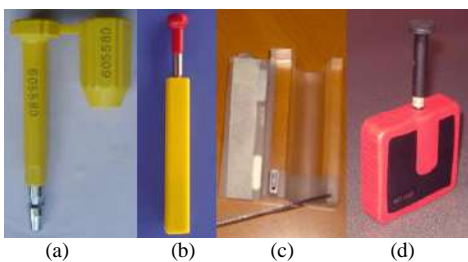

Fig. 4. Container seal (a) mechanical bolt (b) RFID e-seal passive tag bullet (c) RFID e-seal passive tag lay (d) RFID e-seal active tag 2.4 GHz.

In initial testing of RFID system to container used passive bolt e-seal as Fig. 5 (b) but some issue on the design because of tag seem folded inside the packing and reading performance is not optimum, then re-design of tag casing become Fig. 5(c) this type of e-seal reading performance improve and more better compare to previous bolt e-seal, because of environment in container terminal mostly is heavy metal some case reading is not consistence. Final decision on the system design is to use active RFID e-seal in container for effective reading of tag information, the others consideration is active e-seal can store more information made the tag is standalone and information can query mobile by handheld reader. Meantime for driver and vehicle tag the use of passive UHF RFID tag as implemented in PSMS system at container terminal checkpoint is still maintained.

C. Gate Checker

Operational of the container terminal in the previous procedure is run by the gate checker (officer) and another person outside office to do inspection for container condition. New implementation procedure using ICT and RFID technology change the Standard Operational Procedure (SOP) of container terminal. The gate checker needs to stand outside with tablet PC or mobile gadget to check container condition, Fig. 5 shows gate checker doing inspection on a container for clearance in one of container terminal.



Fig. 5. Gate checker receive container and inspection.

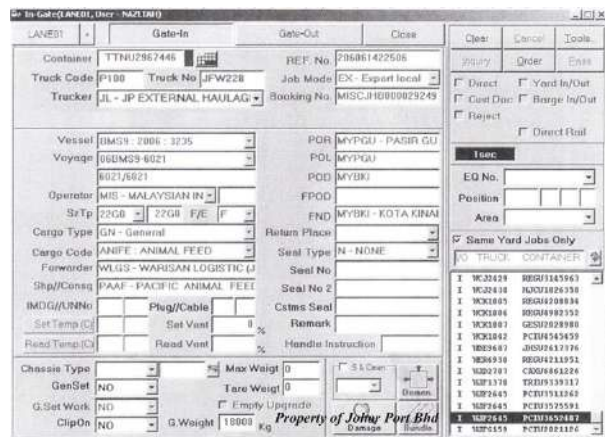

Fig. 6. Screenshot of gate checker application menu.

After all information on the container (including weight and condition of the container) is complete the gate checker clears and prints a ticket for the driver showing the information which block or zone in yard area

to unload. Fig. 6 shows a screenshot of gate checker application software and container information to be clear and conform. The e-seal used in container is recyclable, once transaction is complete and container reaches destination then e-seal can be re-used with new transaction by programming to new container and information.

D. RFID Middleware

The implementation of RFID technology into container terminal operation system as proposed in this research has several parts: the main and most important part is RFID middleware because as the interface between RFID devices, gate checker and container terminal systems (CTMS and PSMS). Fig. 7 shows the complete architecture of the RFID system implemented on the container terminal.

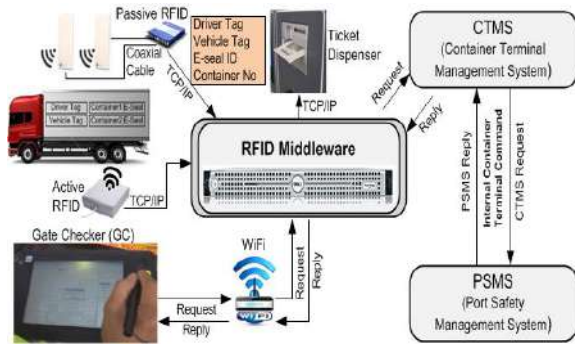

Fig. 7. Architecture of RFID system for receiving gate.

All devices/gadgets connected to the RFID middleware server to serve all parties and return all the information. Passive and active RFID readers collect information from the truck (driver, vehicle, e-seal and container information) then pass it to the middleware. The information received from the truck is only part of data. To obtain complete information and also to verify the data the CTMS and PSMS database is queried. The RFID middleware sends a request according to the necessary information needed. The CTMS returns the desired information. This technique is used to simplify the transactions between the systems. The middleware also serves as gate checker when a request for information is issued from a tablet PC, according to the lane number need.

V. RESULTS, EVALUATION AND COMPARISON

Initial tests of the proposed development of ICT and RFID technology in container terminal were conducted at container receiving gate. The hardware configuration and architecture have been previously discussed as equipment setup. Testing has been done by placing driver and vehicle tags on the truck, e-seal at the back of container. In the initial stage of testing all tags and e-seal used passive type and single lane of container receiving. The results obtained show that the RFID reader captures the RFID tag ID and information when the RFID reader power transmits set to maximum. In the second stage of

testing, results show that multiple ID tags were captured by the reader, without the possibility to distinguish between lanes. This is because the reader power transmits is too high. Thus in the next testing the reader transmits power is adjusted lower so as to read lane-specific coverage area.

Passive RFID tags were previously used as container e-seal in the first trial. However, a lot of technical issues cannot be rectified due to the limitations on passive RFID tags. Using active RFID tags (e.g. as currently used in Shanghai Port) yields better reading. The system contains e-seal with 2.4 GHz, where every protocol and interface uses the same standards. This e-seal has sensors, so that there is tampered record in the e-seal once the seal is unplugged without authorization. Testing on active RFID e-seals does not generate serious technical issues as the active RFID reader can read longer ranges, though some additional equipment are required as earlier mentioned. This version of e-seal results in improved container clearance. Fig. 8 shows a chart of complete cycle timeline container clearance and system communication for a container.

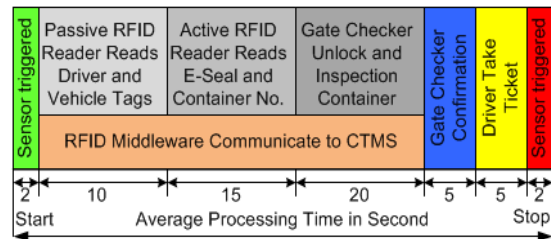

Fig. 8. Reading timeline of container in receiving area.

Reviewing the RFID middleware performance, reveals too many buffer data of RFID tags. This is because the RFID reader keeps reading even when no truck is in the receiving lane. Enhancement and filtering of tag data and unnecessary tag information can be implemented in the software. However, this requires improvement in the reading time. In this scenarios reader only reads when a truck or vehicle is parked into a specific lane. Then the readers start reading the tags. For this a set of sensors are installed for triggering read starts and stops.

TABLE I: CLEARANCE TIME COMPARISON BETWEEN PREVIOUS PROCEDURES TO NEW ICT IMPLEMENTED PROCEDURE

No	Data Collection	Previous Procedure Secs	Container Type (foot)		
			20	20+20	40
1	1 st Container	250	40	65	61
2	2 nd Container	215	43	75	52
3	3 rd Container	296	55	78	72
4	4 th Container	260	40	61	55
5	5 th Container	220	35	69	60
6	6 th Container	289	59	65	62
7	7 th Container	192	50	71	70
8	8 th Container	266	51	55	46
9	9 th Container	236	40	63	48
10	10 th Container	257	52	65	53
Average Time (sec)		248	46.5	66.7	57.9

This method results in improvement of data capture because only tags and e-seal in specific lane and time are captured. Clearance time data are taken from several containers that come into the lane with several container types (20 foot, 40 foot or double 20 foot). Table I shows the difference between of container clearance time using the manual procedure and the new procedure with ICT and RFID system. Results shows very great enhancement and time saving: with the manual procedure the average clearance time is 248 seconds (+/-4 minutes) while with the new procedure the average time is 57 (+/-1 minute) seconds, that is up to 76.6 % time saving.

In addition to time saving, instead of one container clearance at a time, now four containers are at the same cycle time. As already mentioned queuing of containers affects the operation of the terminal, which impacts truck queue on the road to receiving gate-in area. With the new system this is now manageable, and manpower efficient: the number of operators in charge of six lanes decreases from eight to four. Another benefit of the online container monitoring system is better time visibility, improved security, and real time authentication.

VI. CONCLUSION

Development of ICT and RFID system are installed in a container terminal gate-in (receiving) area and implemented using ICT technology for processing information to the CTMS. Several testing scenarios have been conducted to determine the optimal position of RFID equipment. The best position is fixed at container receiving site and RFID equipment is installed for every lane, one set for each lane. Other support equipment was also installed in optimal positions such as Wi-Fi hotspot, ticket dispenser and photoelectric sensor for triggering the RFID reader start/stop. Upon evaluation of container testing results the various issues arise. To address these there is the need for improvement on e-seal, equipment adjustment and fine tuning, in order to perfect performance of RFID reading. The software also enhances and filters unnecessary data. The results have shown great improvement compared to previous manual operating procedure in container processing and clearance. The new system increased container clearance productivity by 76 % and also reduced the clearance time from 4 minutes per container to 1 minute. Other benefits of the proposed system include reduced truck waiting queue, reduced necessary manpower (from eight operators to four), improved container security, real time authentication, and ease of online container tracking.

REFERENCES

- [1] V. F. Valentine, "Global shipping market overview—implications for regional markets," in *Proc. Conference on Competiveness of the Maritime Transport – From Global to Regional Scale' the Baltic Ports*, Bornholm, Denmark, September 4-5, 2014.
- [2] U. Nations, "Review of maritime transport," in *Proc. United Nations Conference on Trade and Development*, 2013.
- [3] M. H. Hakam and W. D. Solvang, "RFID communication in container ports," in *Proc. IEEE 3rd International Conference on Cognitive Infocommunications (CogInfoCom)*, 2012, pp. 351-358.
- [4] S. Abbate, M. Avvenuti, P. Corsini, B. Panicucci, M. Passacantando, and A. Vecchio, "An integer linear programming approach for radio-based localization of shipping containers in the presence of incomplete proximity information," *IEEE Transactions on Intelligent Transportation Systems*, vol. 13, pp. 1404-1419, 2012.
- [5] H. J. Carlo, I. F. A. Vis, and K. J. Roodbergen, "Transport operations in container terminals: Literature overview, trends, research directions and classification scheme," *European Journal of Operational Research*, vol. 236, pp. 1-13, 2014.
- [6] W. Bin and M. Maode, "A server independent authentication scheme for RFID systems," *IEEE Transactions on Industrial Informatics*, vol. 8, pp. 689-696, 2012.
- [7] C. L. D. S. Vieira, A. S. Coelho, and M. M. M. Luna, "ICT implementation process model for logistics service providers," *Industrial Management & Data Systems*, vol. 113, pp. 484-505, 2013.
- [8] M. K. Watfa, U. Suleman, and Z. Arafat, "RFID system implementation in Jebel Ali port," in *Proc. Consumer Communications and Networking Conference*, 2013, pp. 950-955.
- [9] K. K. Hwan and B. H. Hong, "Maritime logistics and applications of information technologies," in *40th International Conference on Computers and Industrial Engineering*, 2010, pp. 1-6.
- [10] C. Zhang, T. Wu, K. H. Kim, and L. Miao, "Conservative allocation models for outbound containers in container terminals," *European Journal of Operational Research*, vol. 238, pp. 155-165, 2014.
- [11] G. Azuara, J. L. Tornos, and J. L. Salazar, "Improving RFID traceability systems with verifiable quality," *Industrial Management & Data Systems*, vol. 112, pp. 340-359, 2012.
- [12] B. Song and Y. Cui, "Productivity changes in Chinese container terminals 2006–2011," *Transport Policy*, vol. 35, pp. 377-384, 2014.
- [13] H. J. Carlo, I. F. A. Vis, and K. J. Roodbergen, "Storage yard operations in container terminals: Literature overview, trends, and research directions," *European Journal of Operational Research*, vol. 235, pp. 412-430, June 1, 2014.
- [14] J. Tao and Y. Qiu, "A simulation optimization method for vehicles dispatching among multiple container terminals," *Expert Syst. Appl.*, vol. 42, pp. 3742-3750, 2015.
- [15] M. A. Malek, S. Hakimi, S. K. A. Rahim, and A. K. Evizal, "Dual-Band CPW-Fed transparent antenna for active RFID tags," *IEEE Antennas and Wireless Propagation Letters*, vol. 14, pp. 919-922, 2015.
- [16] B. Cai, S. Huang, D. Liu, and G. Dissanayake, "Rescheduling policies for large-scale task allocation of autonomous straddle carriers under uncertainty at

- automated container terminals,” *Robot. Auton. Syst.*, vol. 62, pp. 506-514, 2014.
- [17] J. F. Cordeau, P. Legato, R. M. Mazza, and R. Trunfio, “Simulation-based optimization for housekeeping in a container transshipment terminal,” *Computers & Operations Research*, vol. 53, 2015.
- [18] Y. Lu and M. Le, “The integrated optimization of container terminal scheduling with uncertain factors,” *Computers & Industrial Engineering*, vol. 75, pp. 209-216, 2014.
- [19] R. Ferrero, F. Gandino, B. Montrucchio, and M. Rebaudengo, “A fair and high throughput reader-to-reader anticollision protocol in dense RFID networks,” *IEEE Transactions on Industrial Informatics*, vol. 8, pp. 697-706, 2012.
- [20] C. Yuan-Hsin, H. Shi-Jinn, R. S. Run, L. Jui-Lin, C. Rong-Jian, C. Wei-Chih, *et al.*, “A novel anti-collision algorithm in RFID systems for identifying passive tags,” *IEEE Transactions on Industrial Informatics*, vol. 6, pp. 105-121, 2010.
- [21] B. Fabian, T. Ermakova, and C. Muller, “SHARDIS: A privacy-enhanced discovery service for RFID-based product information,” *IEEE Transactions on Industrial Informatics*, vol. 8, pp. 707-718, 2012.
- [22] K. Gihong, M. K. Uddin, and H. Bonghee, “Design and implementation of sensor tag middleware for monitoring containers in logistics systems,” in *Proc. Third International Conference on Sensor Technologies and Applications*, 2009, pp. 393-398.
- [23] E. Evizal, T. A. Rahman, and S. K. A. Rahim, “Active RFID technology for asset tracking and management system,” *Telkomnika*, vol. 11, no. 1, pp. 337-346, March 2013.



Evizal Abdul Kadir received his Master of Engineering (M.Eng) and PhD in Wireless Communication from Faculty of Electrical Engineering Universiti Teknologi Malaysia, Malaysia in 2008 and 2014. He is currently a Senior Lecturer in Universitas Islam Riau (UIR), Indonesia. He have been worked in several companies that provide system solution in telecommunication and radio frequency identification (RFID), currently is continuing his research activity related to the wireless communication, computer networking and information system, Radio Frequency Identification (RFID) and Wireless Sensor Network (WSN). His research interest is in the field of antenna design, smart system, RFID, wireless sensor network and computer networking.