

---

# Santiago High School

The home of Scholars, Achievers and  
Champions!



# Junior Advisement



**Class of 2019**

@b5dad5

WAYS TO JOIN A CLASS



**In-class Instructions**



**Phone or email invites**



**Website link**



**Printable PDFs**

Ask students and parents to text @b5dad5 to 81010

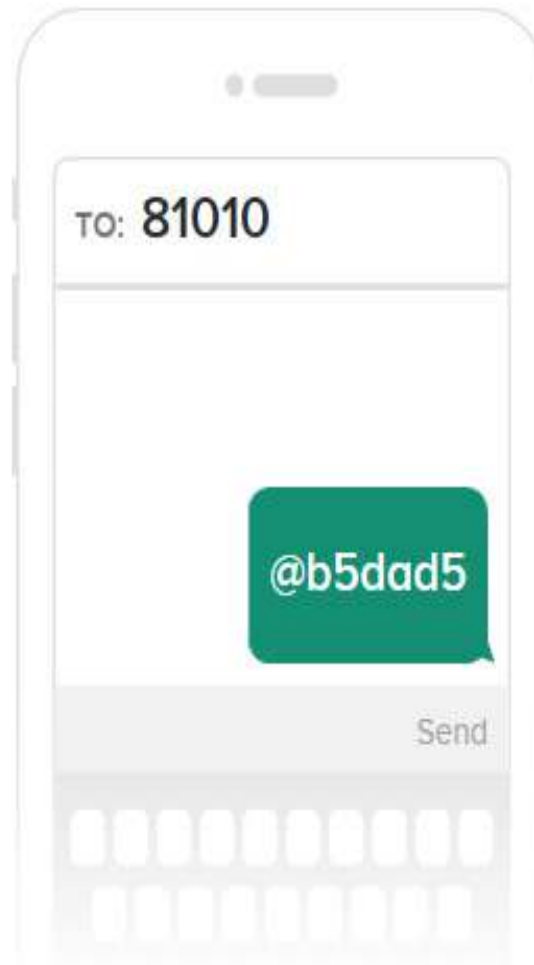

**1 Send your text to 81010**

81010 is the Remind short code we created so people can join your class without seeing your personal information.

[81010 not working?](#)

**2 Text the message @b5dad5**

This is the class code for Class of 2019. Students and parents can always use b5dad5 to join this class.

**SANTIAGO HIGH SCHOOL**  
**11<sup>TH</sup> GRADE ONLINE COURSE SELECTION WORKSHEET**

**SEMESTER 1**

**SEMESTER 2**

Language Arts 3A _____	Language Arts 3B _____
U.S. History 1A _____	U.S. History 1B _____
Elective _____	Elective _____
Elective _____	Elective _____
Elective _____	Elective _____
Elective _____	Elective _____

**<https://studentconnect.cnusd.k12.ca.us>**

**Online registration opens on Feb 6th and closes Feb. 17th**

**You need room in your schedule? We got room!**

**Santiago is now offering**

➤ Zero period PE

➤ Zero period Spanish 2



# High School Graduation Requirements

<b>SOCIAL SCIENCE</b>	3 Years (30 Credits) <ul style="list-style-type: none"><li>• World History</li><li>• U.S. History</li><li>• Government/Economics</li></ul>
<b>LANGUAGE ARTS</b>	4 years of English
<b>MATH</b>	2 years of Math
<b>SCIENCE</b>	3 Years (20 Credits) <ul style="list-style-type: none"><li>• Physical Science</li><li>• Life Science</li></ul>
<b>FINE ART <u>OR</u> WORLD LANGUAGES</b>	1 Year Fine Art/Performing Arts <u>OR</u> 1 Year World Language
<b>PHYSICAL EDUCATION</b>	2 Years (20 credits)
<b>HEALTH</b>	1 semester (5 credits)
<b>ELECTIVE CREDITS</b>	15 per semester
<b>TOTAL CREDITS</b>	<b>220 Credits</b>

<b>SUBJECT</b>	<b>CAL STATE UNIVERSITY</b>	<b>UNIVERSITY OF CALIFORNIA</b>
<b>SOCIAL SCIENCE</b>	<b>2 Years</b> <b>1 yr. World History</b> <b>1 yr. U.S. History</b> <b>1 semester of Gov.</b>	<b>2 Years</b> <b>1 yr. World History</b> <b>1 yr. U.S. History</b> <b>1 semester of Gov.</b>
<b>LANGUAGE ARTS</b>	<b>4 Years English</b>	<b>4 Years English</b>
<b>MATH</b>	<b>3 Years</b> <b>Integrated Math 1, Integrated Math 2 and Integrated Math 3 or Algebra 2 (4 Yrs. Rec:)</b>	<b>3 Years</b> <b>Integrated Math 1, Integrated math 2 and Integrated Math 3 or Algebra 2 (4 Yrs. Rec:)</b>
<b>SCIENCE</b>	<b>2 Years Lab Science</b> <b>Refer to A-G List!</b>	<b>2 Years Lab Science (3 yrs. Recommended Biology, Chemistry and Physics)</b>
<b>WORLD LANGUAGE</b>	<b>2 yrs. Same World Language</b>	<b>2 yrs. Same World language (3 years recommended)</b>
<b>FINE ART</b>	<b>1 yr. Visual and Performing Art</b>	<b>1 yr. Visual and Performing Art</b>
<b>ELECTIVE CREDITS</b>	<b>1 Yr. of Advanced course in Math, English, lab Science, Foreign Language, Social Science or Fine Arts.</b>	<b>1 yr. of Advanced course in Math, English, lab science, Foreign language, Social Science or Fine Arts.</b>
<b>ACT <u>OR</u> SAT EXAMS</b>	<b>ACT <u>or</u> SAT</b>	<b>ACT <u>or</u> SAT</b>

# **What is A-G**

- ✓ **The intent of the “A-G” subject requirements is to ensure that students have attained a body of general knowledge that will provide a wide range and perspective to new, more advanced study.**
- ✓ **The Requirements for University of California and California State University Eligibility. All requirements must be completed with a “C” grade or better. D’s and F’s are not excepted!**

# California Colleges

CaliforniaColleges.edu

California Colleges is the one-stop website for information about higher education in California for students, counselors, and parents.

- ✓ Explores the full range of accredited public and non-profit colleges and universities in California and nationwide.
- ✓ Determine the careers that best match your skills and interest.
- ✓ Match schools and majors with your career interest.
- ✓ **Your classes are automatically transferred to your college application.**



# **You MUST have** **220 Credits to graduate!**

**\*\*You only get credit for a class if you pass it with a “D” or better. Any class you receive an “F” in does not count towards credits for Graduation!\*\***

# How do I make up credits for Graduation?

## 1. Lee Pollard High School

- Must have good attendance and good behavior to be eligible

## 2. Summer School

## 3. Speak with your COUNSELOR asap!

# Advantages of Taking Online Courses

## World History, U.S. History, Government/Economics

### Fits your Schedule

- You can free up a period to leave campus early.
- Coursework is done outside of the classroom.
- Allows time for other pursuits. This class is not in your daily schedule.

### Self Directed Learning

- All due dates are preset, you decide your pacing to meet them.
- Instant playbacks and review. You just need to take notes on your lesson and use your notes for all your tests.
- No books are needed for the class.

### Accessibility

- Online teachers are just a text or email away for help.
- Develops self control and commitment. This will help you in your college classes.
- Courses are A-G approved for college credits

**You must have a minimum of a 3.0 GPA**

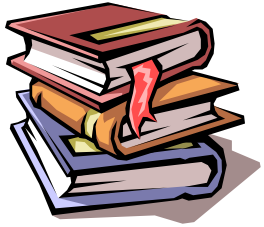

# LANGUAGE ARTS

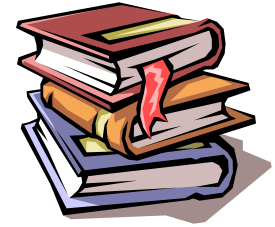

-ALL Students will take Language Arts 3a/b.

--Students wanting to take AP Language Arts should be currently receiving a “B” or better in Lang. Arts 2, or a “C” or better in Honors.

-Must complete HONORS CONTRACT and summer reading assignments!

# What MATH Will I Take?

<u>If I am taking:</u>	<u>And received:</u>	<u>I will be place into:</u>
<b>1. Integrated Math 1</b>	<ul style="list-style-type: none"> <li>• “C” or Better</li> <li>• “D” or an “F”</li> </ul>	<ul style="list-style-type: none"> <li>• Integrated Math 2</li> <li>• <a href="#"><u>See your Counselor</u></a></li> </ul>
<b>2. Integrated Math 2</b>	<ul style="list-style-type: none"> <li>• “C” or Better</li> <li>• “D” or an “F”</li> </ul>	<ul style="list-style-type: none"> <li>• Integrated Math 3</li> <li>• <a href="#"><u>See your counselor</u></a></li> </ul>
<b>3. Integrated Math 3</b>	<ul style="list-style-type: none"> <li>• “C” or Better</li> <li>• “D” or an “F”</li> </ul>	<ul style="list-style-type: none"> <li>• Pre Cal/Stats/Trig</li> <li>• <a href="#"><u>See your counselor</u></a></li> </ul>
<b>5. Pre Calculus</b>	<ul style="list-style-type: none"> <li>• “C” or Better</li> <li>• “D” or an “F”</li> </ul>	<ul style="list-style-type: none"> <li>• Calculus a/b or Statistics</li> <li>• <a href="#"><u>See your Counselor</u></a></li> </ul>
<b>6. Calculus</b>	<ul style="list-style-type: none"> <li>• “C” or Better</li> <li>• “D” or an “F”</li> </ul>	<ul style="list-style-type: none"> <li>• AP Cal. AB/BC</li> <li>• See Current Math teacher for recommendation.</li> <li>• <a href="#"><u>See your Counselor</u></a></li> </ul>



## Life Science

Biology 1a/b

Zoology 1a/b

Anatomy & Physiology 1a/b

Biology 2 a/b AP\*\*



## Physical Science

Natural Science

Oceanography 1a/b

Astronomy 1a/b

Physics 1a/b

Physics 1a/b AP\*\*

Physics 2a/b AP\*\*

Physics C AP\*\*

Chemistry 1a/b

Chemistry 1a/b Hon.\*\*

Chemistry 2a/b AP\*\*

Environmental Science 1a/b

Environmental Science 1a/b AP\*\*

**\*\* Denotes Teacher approval by signature is required.**

**Underlined classes meet U.C./Cal State requirements.**

# Fine Arts

- **Art & History of Fashion 1a/b**
- **Drawing & Painting 1a/b**
- **Animation 1 a/b**
- **Ceramics 1 a/b**
- **Digital Photography 1a/b**
- **Graphic Design 1a/b**
- **Video Production 1 a/b**



# *Advanced Fine Arts*

- **Animation 2a/b**
- **Ceramics 2a/b**
- **Digital Photography 2a/b**
- **TV Production 1 a/b\*\* and 2a/b\*\* “Shark TV”**
- **Art & History of fashion 2 a/b**
- **A.P. Studio Art 1a/b\*\***
- **A.P. Art History 1a/b**

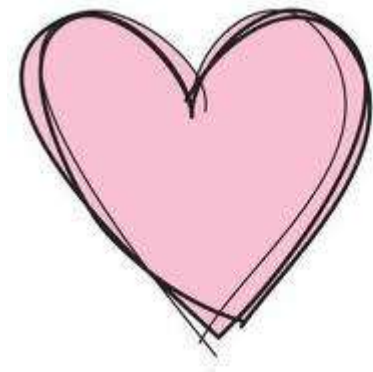

love  
the  
visual  
arts



# Performing Arts:

- Concert Choir 1 a/b (Girls)
- Baritone Choir 1 a/b (Boys)
- Treble Choir 1 a/b\*\*
- Madrigals 1 a/b\*\*



- Theater Arts 1a/b
- Theater Arts 2a/b
- Theater Arts 3a/b
- Theater Arts 4a/b
- Theater Production 1a/b\*\*
  
- **Beginning Electric Keyboarding**
  
- Concert Band 1a/b
- Symphonic Band 1a/b
- Jazz Ensemble 1a/b
- Jazz Ensemble 2a/b
- Festival Winds 1a/b

# New: AP Music Theory



## For the Serious Musician

- Equivalent to a first year college course in Music Theory.
- Prerequisite – Basic fundamentals of music notation. Can read notes, rhythms, scales, key signatures, etc.
- Preferred that you are currently in a performing group such as band, choir or can play the piano.

## Goals of the Course

- To develop the students' ability to recognize, understand and describe the elements that are heard or seen in a musical score.
- Components of course
  - Music Aural Skills (ear-training)
  - Sight Singing Skills
  - Written Musical Skills
  - Composition Skills
  - Music Analytical Skills

For more information see Mrs. Garrett in room B130

# 23 Advanced Placement Courses challenge yourself Shark!



AP Art History

AP Biology

AP Chemistry

AP Physics 1

AP Physics 2

AP Physics C

AP Environmental Science

AP Calculus AB

AP Calculus BC

AP Statistics

AP World History

AP European History

AP Lit & Comp.

AP French

AP Spanish Language

AP Spanish Lit.

AP Psychology

AP Computer Science

AP Computer Science Principles

AP Studio Art

AP U.S. History

AP Government

AP Music Theory

See your counselor & visit [CollegeBoard.org](http://CollegeBoard.org) for additional information on AP courses

Santiago High school

Home of Scholars, Achievers and Champions

# Courses for You!



BUSINESS COURSES	SEM/YEAR	ARTICULATE	A - G
Applied Accounting	Y	✓	✓
Computerized Accounting	Y	✓	
Business Management & Leadership	Y	✓	✓
Business & Personal Law	Y	✓	✓
Intro to Business	Y	✓	✓
Internship	Y		
Work Experience	Y		

# Courses for You!



TECHNOLOGY COURSES	SEM/YEA R	ARTICULATE D	A - G
Technology Applications	Y	✓	
Intro to MS Office – (Word, Excel PowerPoint)	Y	✓	
Intro to Adobe – (Photoshop, Illustrator, InDesign)	S		
AP Computer Science Principles	Y		
3D Animation	Y		
History of Video Games	S	✓	
Intro to Simulation & Game Design	S	✓	
Intro to Game Programming	Y	✓	
Digital Drawing for Game Art	Y	✓	
Video Production	Y		
TV Production	Y		

# ARCH/ENGINEERING

- Intro to Engineering/Architectural Design
- Architectural Design 1a/b
- Architectural Design 2a/b
- CAD 2a/b
- CAD 3-D Animation 1a/b
- Design Manufacturing & Technology 1a/b
- 3 D Printing 1a/b
- Green Building Design
- Interior Design (s)

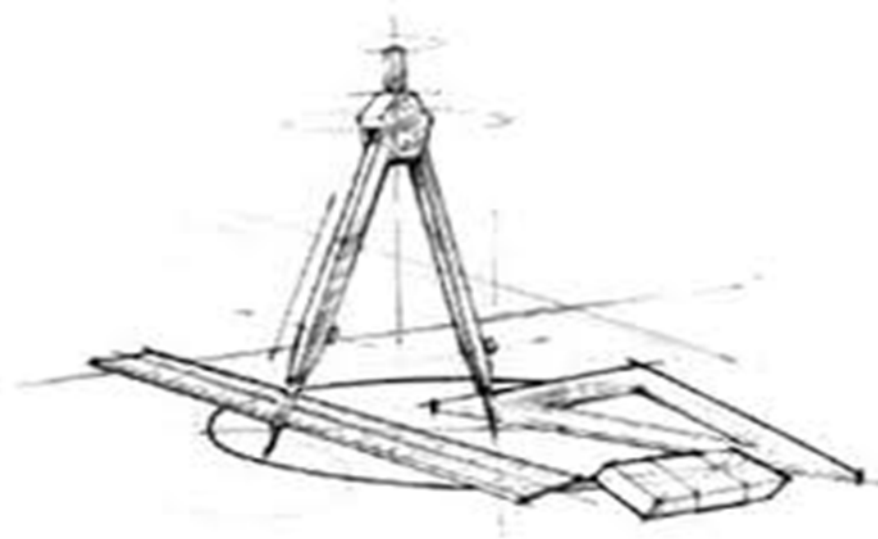

# Making Of The American Mind



**Making of the American Mind is an integrated cross-curricular program which infuses history, Language Arts and visual and performing arts in order to appeal to multiple learning styles for teaching American History and American Literature to regular education eleventh grade students. The program seeks to engage students through art and drama, allowing them to embody historical figures and recreate historical events.**

# Testing for College Admissions

- **SAT** : Used to measure verbal, math and writing abilities.
- **SAT Subject**: Specific subject tests, i.e.- Social Sciences, Foreign Language, Math, etc.
  - **UC Campuses do not required SAT II Subject, but your major may request the exam.**
- **ACT**: Measures English, Math, Social Science & Natural Science. May be used as an alternate to the SAT for some colleges.



# CNUSD Free & Reduced Lunch Program



- Benefits:

- You could receive lunch for free, and it is discrete and confidential!
- You could qualify for:
  - ✓ College application fee waivers.
  - ✓ SAT & ACT fee waivers.

- How to Apply:

- Check out the income requirements and apply online at:

[www.cnusd.k12.ca.us/Page/95](http://www.cnusd.k12.ca.us/Page/95)

- Or visit CNUSD Child Nutrition  
300 S. Buena Vista Ave.  
Corona, CA 92882







# National Collegiate Athletic Association

- All students need to register with the NCAA Eligibility Center at the end of their Junior Year.

[www.eligibilitycenter.org](http://www.eligibilitycenter.org)

# College and Career Fair: October 2017



# Summer School:

**WHEN: June 12th – July 7th**

Summer school sign ups will begin  
February/ March (**See Counselor**)



**Be a champ and Pass all of your classes!**